

PARTS MANUAL

Serial Number 11000578 and Up

BXMT3209 **TRAILER CHIPPER-SHREDDER**

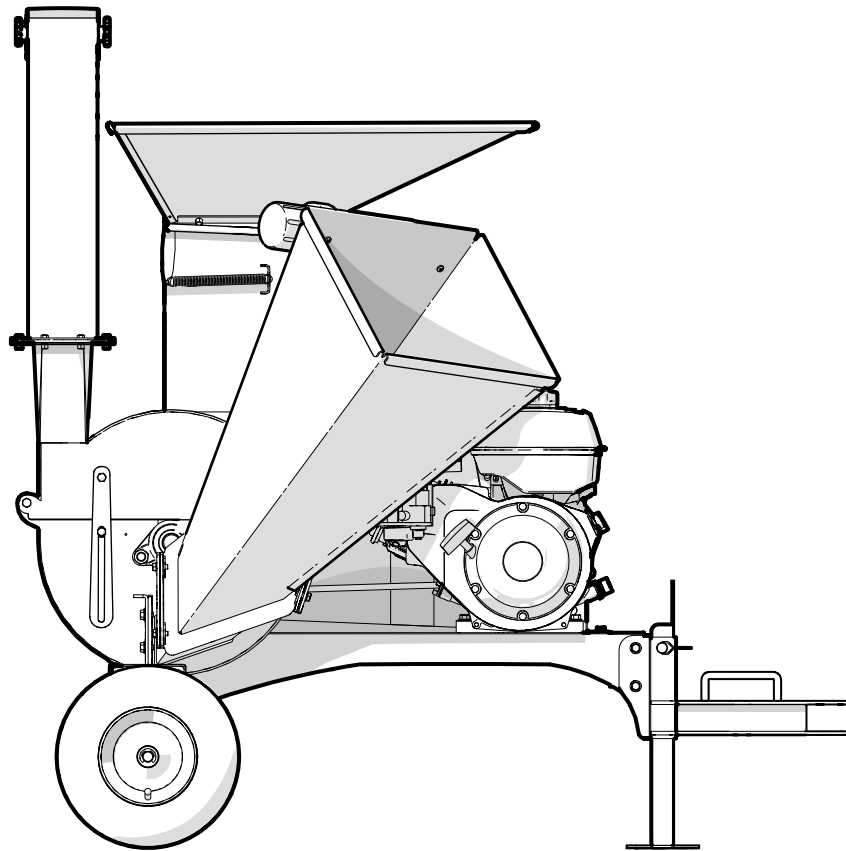

Foreword

This Wallenstein parts manual is prepared to assist customers in ordering quality OEM replacement parts.

Regular maintenance combined with replacing old, worn or broken parts with the correct OEM parts is essential in prolonging the life of your Wallenstein product. Refer to this manual to identify replacement parts.

To order parts, contact your Wallenstein dealer or distributor. Have the product model and serial number handy.

If your dealer is no longer available, please go to WallensteinEquipment.com. At the bottom of the page, select Dealer Locator.

All information contained in this parts manual is current as per the revision date at the bottom of the page. Wallenstein reserves the right to change product specifications at any time without notice.

If your product specifications differ from those contained in this manual, contact Wallenstein for current information.

Reproduction of information in this parts manual is prohibited without prior written permission from Wallenstein Equipment Inc.

Wallenstein Equipment Inc. • © 2023

WARNING!

For safety, operation, and maintenance information, see the Operator's Manual.

Maintenance should be performed by trained personnel only.

Serial Number Location

Always provide the model and serial number of your Wallenstein product when ordering parts or requesting service or other information. The serial number is on the product information plate as shown below.

Record your product information here for future reference.

Model _____

Serial Number _____

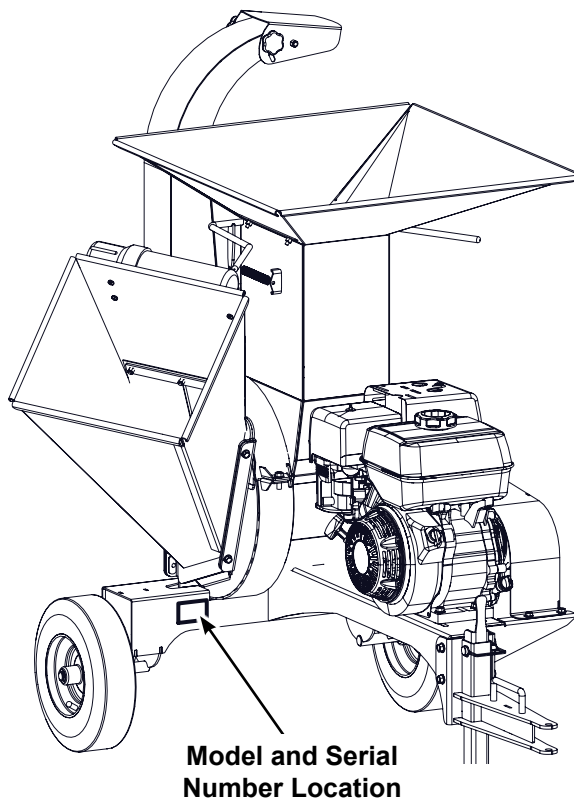

www.wallensteinequipment.com

Contents

Main Parts	4
Blower Assembly	5
Discharge Chute Assembly	6
Rotor Assembly	7
Hopper Flap	8
Jockey Wheel Option	8
Decal Layout	9
Accessories	11
Common Bolt Torque Values	12

Main Parts

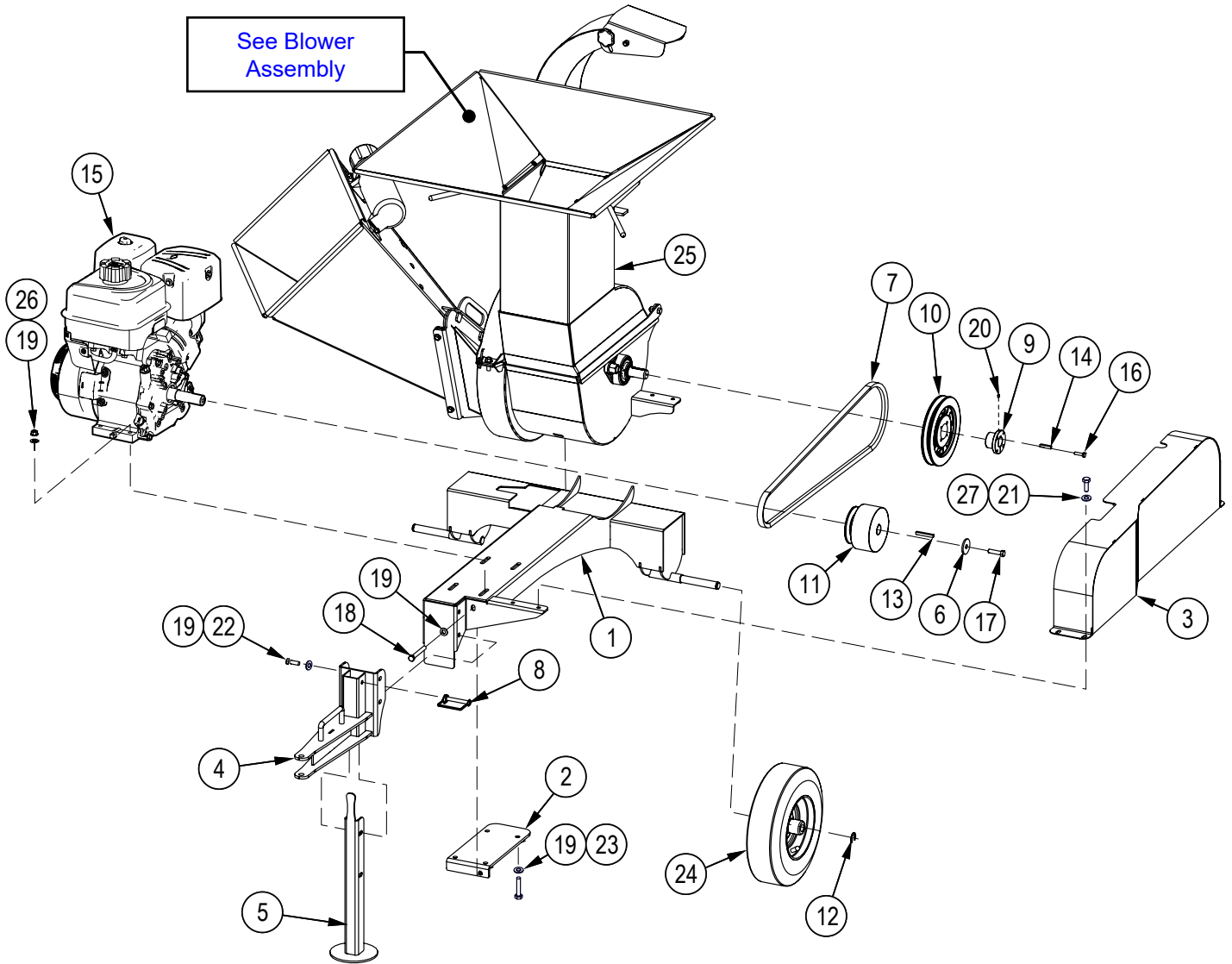

Item No.	Part No.	Description	Qty
1	1057W733	Main Base	1
2	1057W732	Belt Tightener	1
3	1057W734	Shield	1
4	1057W702	Tongue Weldment	1
5	1057W701	Jack Stand	1
6	1056L665	Clutch Washer	1
7	Z41160	Single Belt, B64	1
8	Z12432	Snap Lock Pin, 3/8" x 2-1/2"	1
9	Z41510	Hub, L x 1"	1
10	Z41613	Sheave, MBL74 x L	1
11	Z41803	Centrifugal Clutch, 1B36 x 1"	1
12	Z46203	E-Style Retaining Ring, 3/4"	2
13	Z46531	Key, 1/4" x 1/4" x 2"	1

Item No.	Part No.	Description	Qty
14	Z46534	Key, 1/4" x 1/4" x 1-1/4"	1
15	Z47765	Vanguard 300, Rope	1
16	Z71110	Hex Bolt, 1/4NC x 1"	2
17	Z71377	Hex Bolt, 3/8NF x 1-1/2"	1
18	Z71391	Hex Bolt, 3/8NC x 3" Full Threads	1
19	Z73131	SAE Washer, 3/8"	9
20	Z74102	Set Screw, #10NC x 1/4"	1
21	Z71207	Hex Bolt, 5/16NC x 3/4"	4
22	Z71310	Hex Bolt, 3/8NC x 1"	4
23	Z71320	Hex Bolt, 3/8NC x 2"	4
24	Z91311	4.10-6NHS 2PR 290lbs Sawtooth x 3/4"	2
25	1056A901	Blower Assembly for BXMT	1
26	Z72231	Hex Lock Nut, 3/8NC	4
27	Z73122G8	SAE Washer, 5/16" Grade 8	4

Blower Assembly

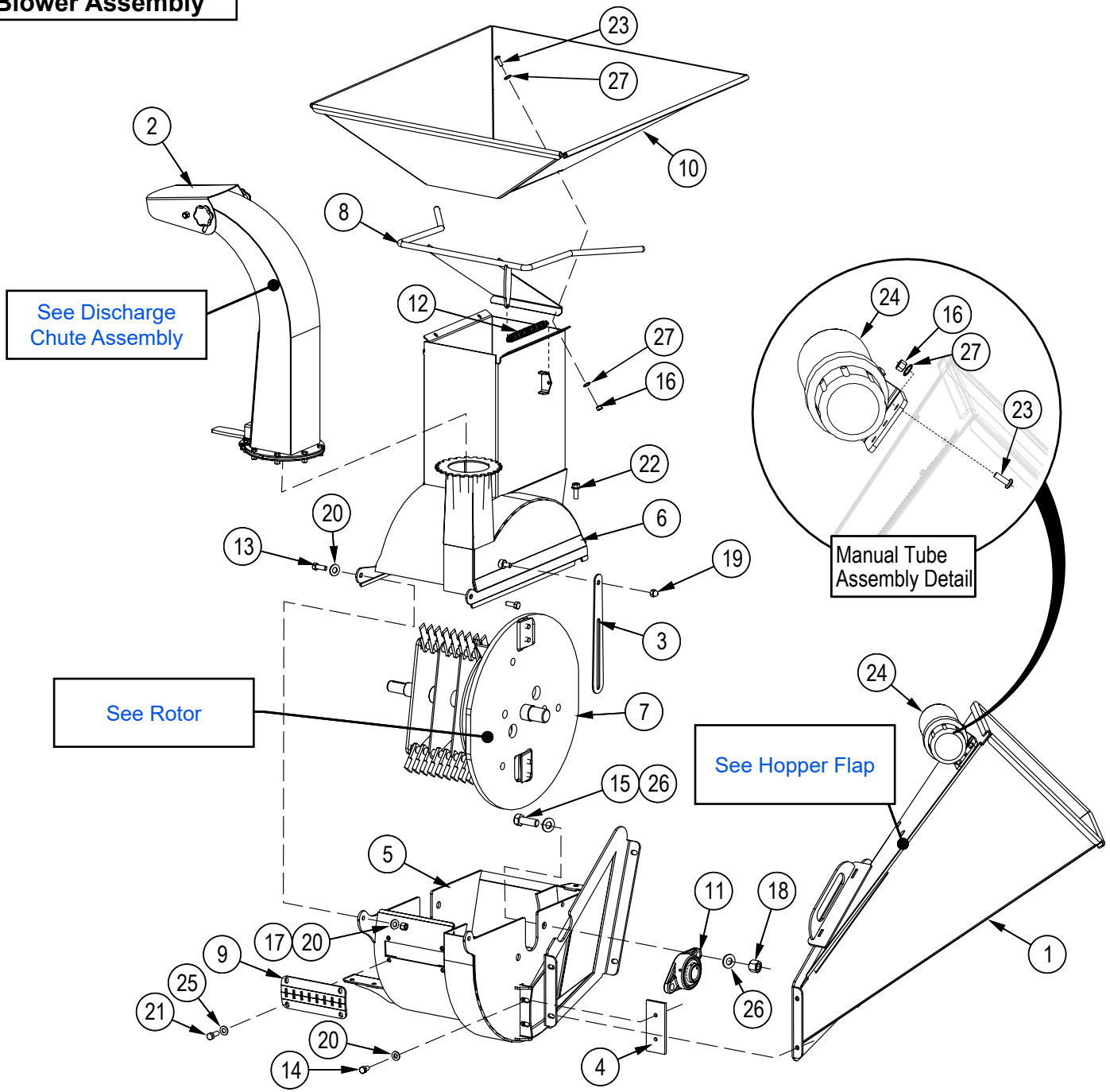

Item No.	Part No.	Description	Qty
1	1018W107	Chipper Chute	1
2	1056A302	Assembly, Discharge Chute	1
3	1056L229	Positive Stop Plate	1
4	1056M304	Knife, 3" Ledger	1
5	1056W101	Housing, Bottom Rotor	1
6	1056W102	Housing, Upper Rotor	1
7	1056W103	Rotor	1
8	1056W107	Shredder, Chute Flapper	1
9	1056W610	Concave	1
10	1056W617	Hopper Shredder Top	1
11	Z25103	2-Bolt Flange Bearing UCFL206-20	2
12	Z31301	Ext Spring 17mmOD x 140mm x 0.080"	1
13	Z71312	Hex Bolt, 3/8NC x 1 1/4"	2

Item No.	Part No.	Description	Qty
14	Z71372G8	Hex Bolt, 3/8NF x 5/8" G8	2
15	Z71617	Hex Bolt, 5/8NC x 1-3/4"	4
16	Z72211	Hex Lock Nut, 1/4NC	7
17	Z72231	Hex Lock Nut, 3/8NC	2
18	Z72261	Hex Lock Nut, 5/8NC	4
19	Z72911	Acorn Nut, 3/8NC	2
20	Z73131	SAE Washer, 3/8"	4
21	Z71210	Hex Bolt, 5/16NC x 1"	8
22	Z76134	Flange Bolt, 3/8NC x 1"	1
23	Z78318	Machine Screw, 1/4NC x 7/8"	7
24	Z96503	Manual Tube, 3-1/2" Short	1
25	Z73122G8	SAE Washer, 5/16" Grade 8	4
26	Z73161G8	SAE Washer, 5/8" Grade 8	4
27	Z73111G8	SAE Washer, 1/4" Grade 8	7

Discharge Chute Assembly

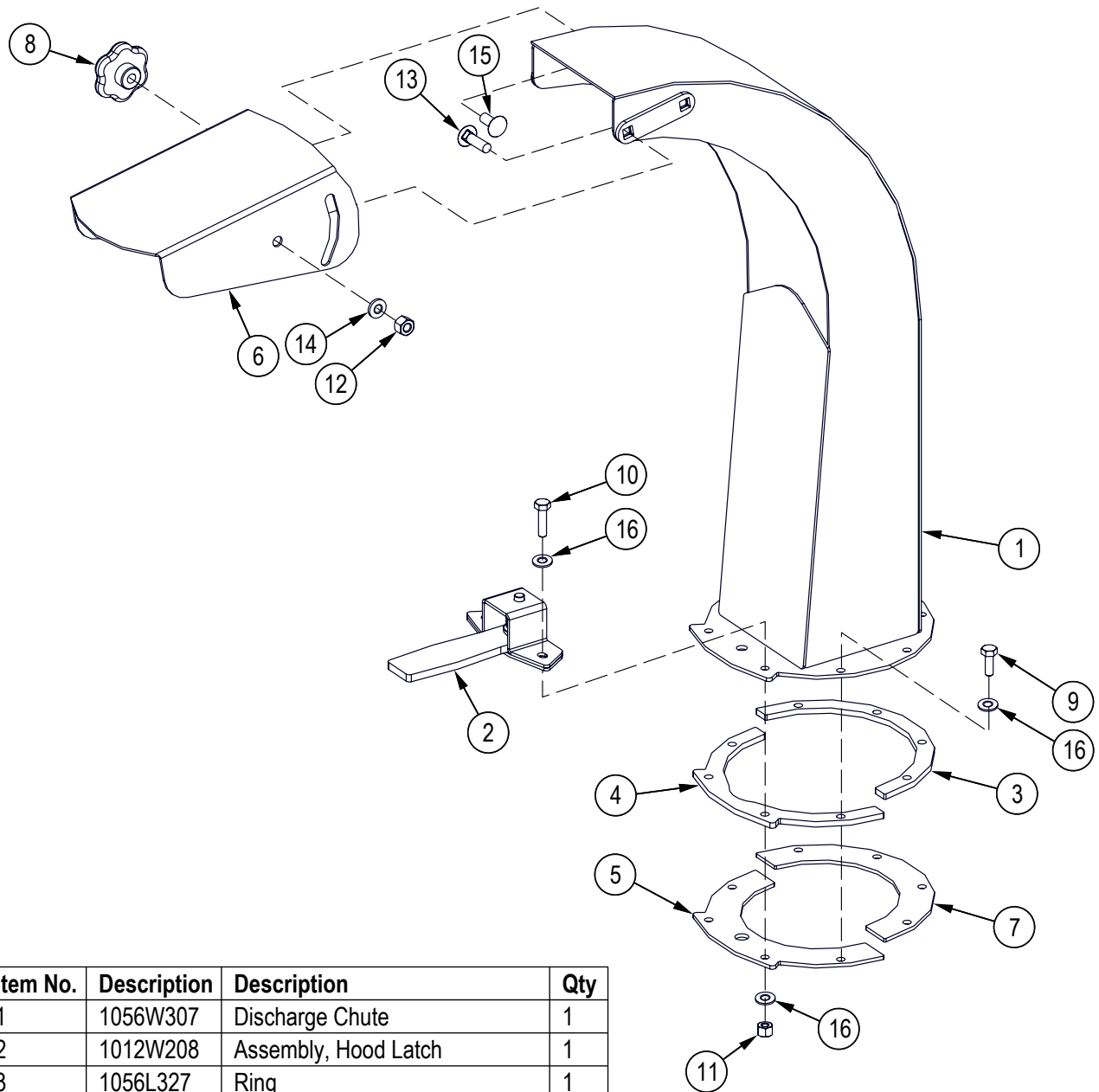

Item No.	Description	Description	Qty
1	1056W307	Discharge Chute	1
2	1012W208	Assembly, Hood Latch	1
3	1056L327	Ring	1
4	1056L329	Plate, Spacer Ring	1
5	1056L330	Plate, Hood Capture	1
6	1056L333	Deflector, Discharge Chute	1
7	1056L334	Ring	1
8	Z19313	Hand Knob, 5/16NC Female Stud	2
9	Z71110	Hex Bolt, 1/4NC x 1"	6
10	Z71112	Hex Bolt, 1/4NC x 1 1/4"	2
11	Z72211	Hex Lock Nut, 1/4NC	8
12	Z72221	Hex Lock Nut, 5/16NC	2
13	Z76225	Carriage Bolt, 5/16NC x 1"	4
14	Z73122G8	SAE Washer, 5/16" Grade 8	2
15	Z76221	Carriage Bolt, 5/16NC x 3/4"	2
16	Z73111G8	SAE Washer, 1/4" Grade 8	16

Rotor Assembly

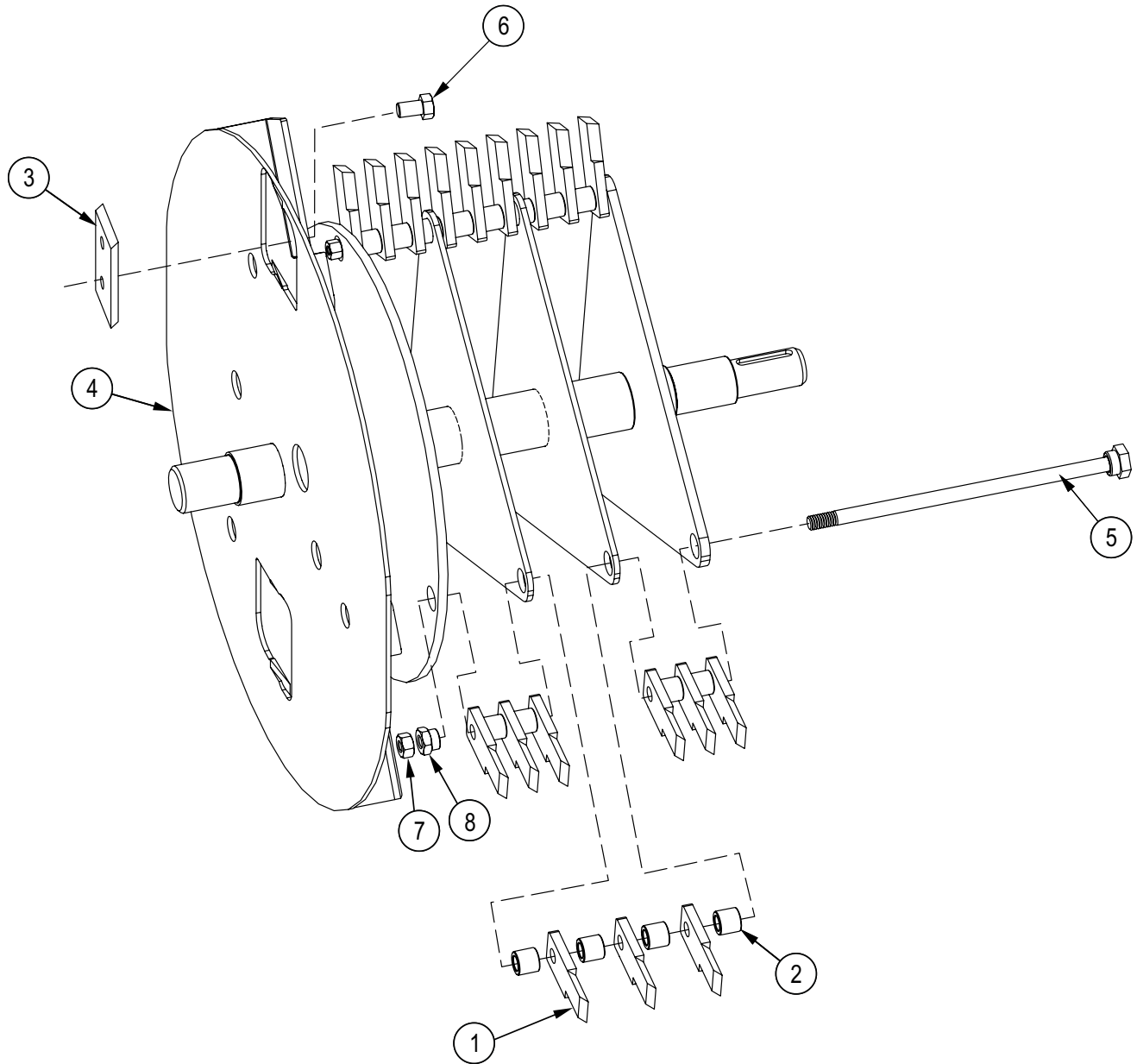

Item No.	Part No.	Description	Qty
1	1056M108	Knife,Shredder	27
2	1056M115	Spacer, Shredder .580	24
3	1056M303	Knife, 3" Rotor	2
4	1056W103	Rotor	1
5	1056W614	Hammer Retainer Pin	3
6	Z71372G8	Hex Bolt, 3/8NF x 5/8" G8	4
7	Z72231	Hex Lock Nut, 3/8NC	3
8	1056M626	Retainer Rod Head	3

Hopper Flap

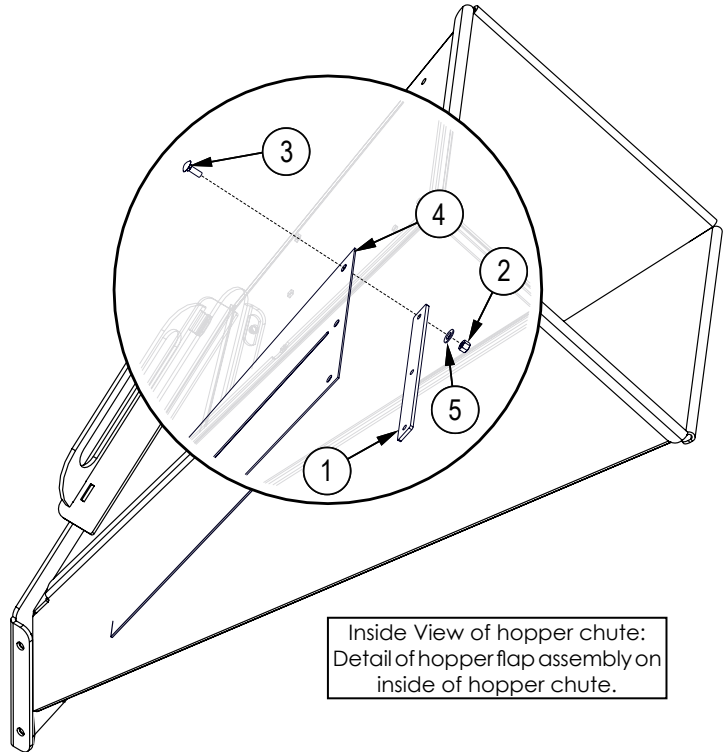

Inside View of hopper chute:
Detail of hopper flap assembly on
inside of hopper chute.

Item No.	Part No.	Description	Qty
1	1018L994	Chipper Chute Flap Clamp	1
2	Z72211	Hex Lock Nut, 1/4NC	3
3	Z76212	Carriage Bolt, 1/4NC x 1"	3
4	1056S604	Flap, Hopper	1
5	Z73111G8	SAE Washer, 1/4" Grade 8	3

Jockey Wheel Option

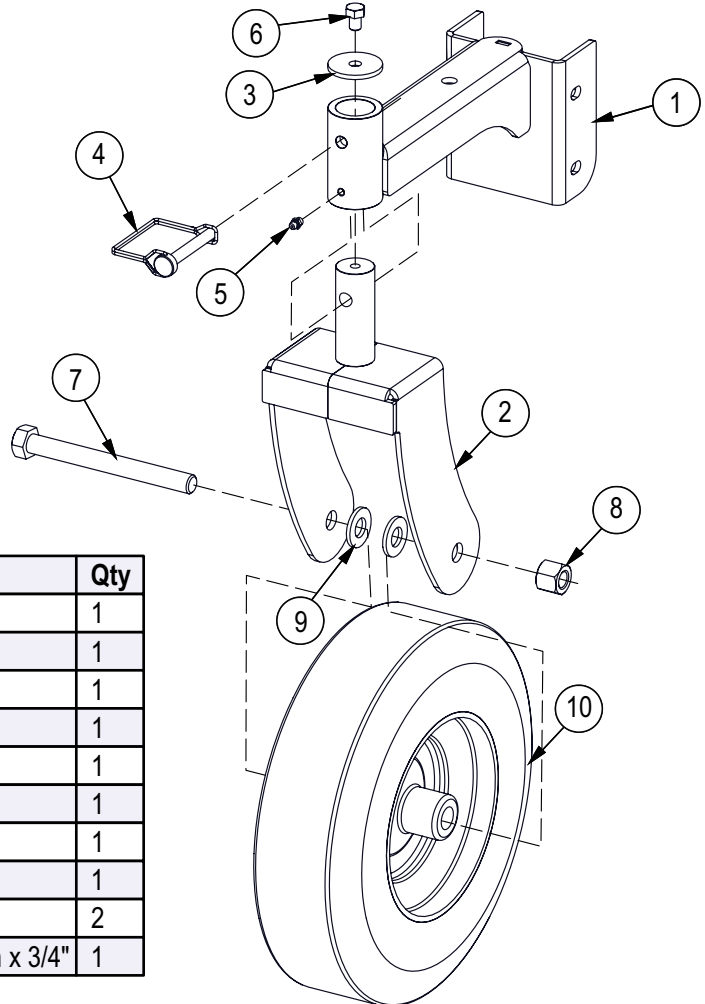

Item No.	Part No.	Description	Qty
1	1082W530	Jockey Option	1
2	1082W531	Yoke, Jockey	1
3	2060L008	Washer, 3/8" Extra Wide	1
4	Z12432	Snap Lock Pin, 3/8" x 2-1/2"	1
5	Z29202	Grease Fitting, 1/4NF	1
6	Z71305	Hex Bolt, 3/8NC x 1/2"	1
7	Z71660	Hex Bolt, 5/8NC x 6"	1
8	Z72261	Hex Lock Nut, 5/8NC	1
9	Z73161	SAE Washer, 5/8"	2
10	Z91311	4.10-6NHS 2PR 290lbs Sawtooth x 3/4"	1

Decal Layout

IMPORTANT! If parts are replaced that have safety signs on them, new signs must be applied. Safety signs must always be replaced if they become damaged, are removed, or become illegible.

Safety signs are included in the product decal kit available from your authorized dealer. Decals are not available separately.

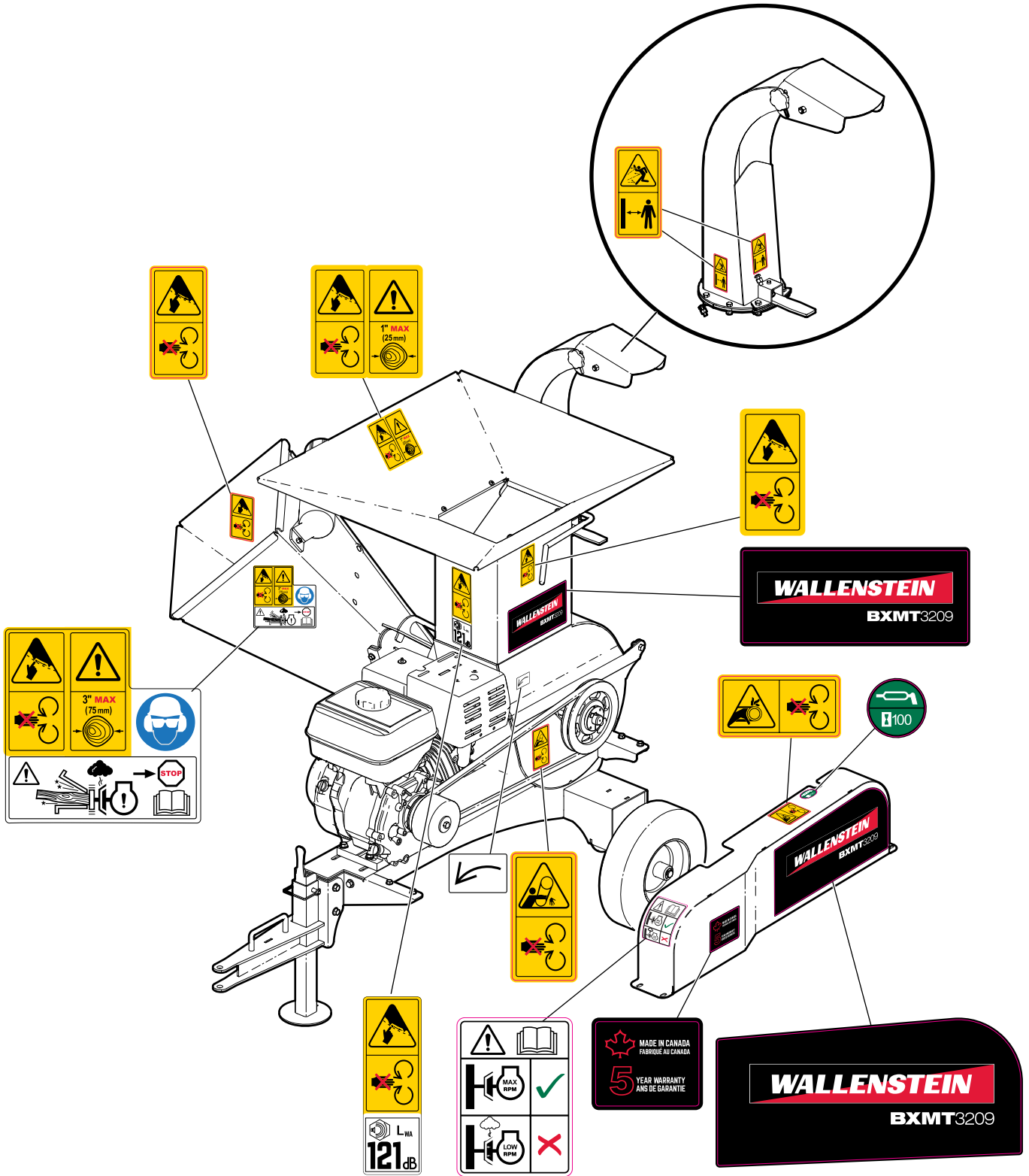

Decal Layout

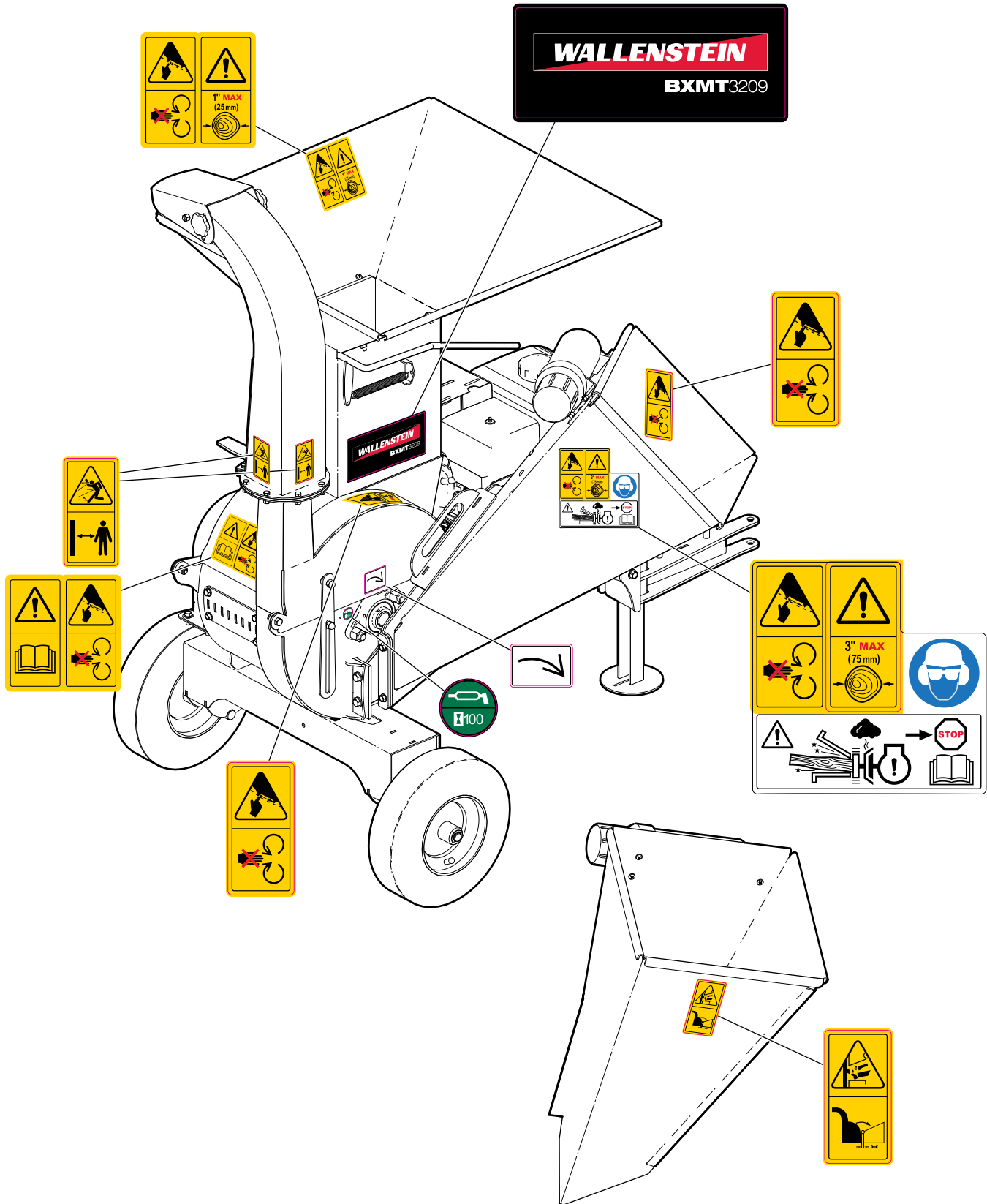

Accessories

Call your dealer for pricing and availability

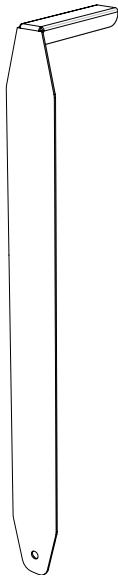

Ledger Clearance Setting Gauge

P/N 1012L269

An easy and accurate way of setting the critical clearances between the ledger blade and the rotor chipper blade.

Common Bolt Torque Values

Checking Bolt Torque

The tables shown give correct torque values for various bolts and capscrews. Tighten all bolts to the torque values specified in the table, unless indicated otherwise. Check tightness of bolts periodically.

IMPORTANT! If replacing hardware, use fasteners of the same grade.

IMPORTANT! Torque figures indicated in the table are for non-greased or non-oiled threads. Do not grease or oil threads unless indicated otherwise. When using a thread locker, increase torque values by 5%.

 **NOTE:** Bolt grades are identified by their head markings.

Imperial Bolt Torque Specifications

Bolt Diameter	Torque Value					
	SAE Gr. 2		SAE Gr. 5		SAE Gr. 8	
	lbf•ft	N•m	lbf•ft	N•m	lbf•ft	N•m
1/4"	6	8	9	12	12	17
5/16"	10	13	19	25	27	36
3/8"	20	27	33	45	45	63
7/16"	30	41	53	72	75	100
1/2"	45	61	80	110	115	155
9/16"	60	95	115	155	165	220
5/8"	95	128	160	215	220	305
3/4"	165	225	290	390	400	540
7/8"	170	230	420	570	650	880
1"	225	345	630	850	970	1320



SAE Gr. 2



SAE Gr. 5



SAE Gr. 8

Metric Bolt Torque Specifications

Bolt Diameter	Torque Value			
	Gr. 8.8		Gr. 10.9	
	lbf•ft	N•m	lbf•ft	N•m
M3	0.4	0.5	1.3	1.8
M4	2.2	3	3.3	4.5
M6	7	10	11	15
M8	18	25	26	35
M10	37	50	52	70
M12	66	90	92	125
M14	83	112	116	158
M16	166	225	229	310
M20	321	435	450	610
M30	1,103	1 495	1,550	2 100



8.8



10.9