

PARTS MANUAL

Serial Number 270001 & up

WP270 Firewood Processor

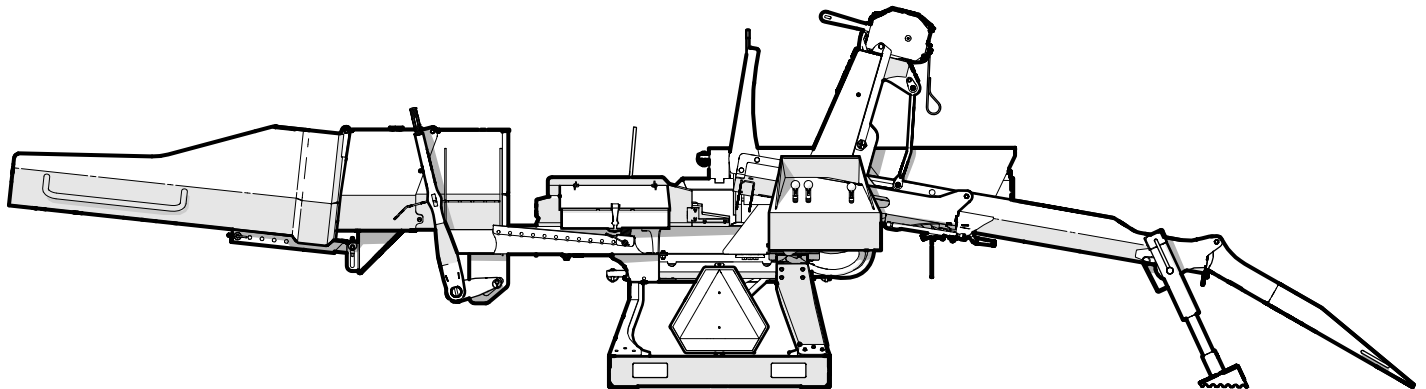

Foreword

This Wallenstein parts manual is prepared to assist customers in ordering quality OEM replacement parts.

Regular maintenance combined with replacing old, worn or broken parts with the correct OEM parts is essential in prolonging the life of your Wallenstein product. Refer to this manual to identify replacement parts.

To order parts, contact your Wallenstein dealer or distributor. Have the product model and serial number handy.

If your dealer is no longer available, please go to our website: <http://wallensteinequipment.com> and click on the [Dealer Locator](#) to find the nearest dealer.

All information contained in this parts manual is current as per the revision date at the bottom of the page. Wallenstein reserves the right to change product specifications at any time without notice.

If your product specifications differ from those contained in this manual, contact Wallenstein for current information.

Reproduction of information in this parts manual is prohibited without prior written permission from Wallenstein Equipment Inc.

Wallenstein Equipment Inc. • © 2021

WARNING!

Refer to the operators manual for safe operation and maintenance.

Maintenance should be performed by trained personnel only.

Serial Number Location

Always provide the model and serial number of your Wallenstein product when ordering parts or requesting service or other information. This information is found on the product information plate as shown below.

Record your product information here for future reference.

Model _____

Serial Number _____

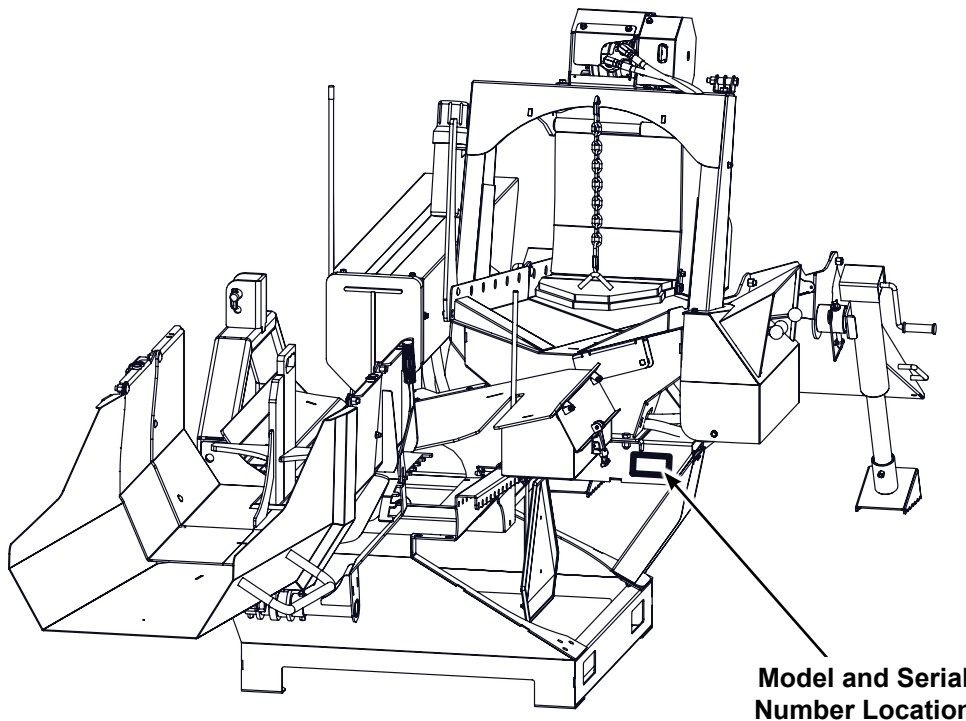

www.wallensteinequipment.com

Contents

Splitter Chute Assembly.....	4
Lead In Chute Assembly	5
Log Hold Down Assembly.....	6
Splitter Main Frame Assembly.....	7
Log Chute Assembly	8
Three Point Hitch Frame Assembly.....	9
Hydraulic Splitter Assembly	10
Hydraulic Winch	11
Winch Drum.....	12
Tool Box Lid.....	13
Handle Clamp	13
Cylinder.....	14
License Lamp	14
Valve Assembly.....	15
Closed Center Plug.....	16
Hydraulic Circuit	17
Decal Layout.....	18
Control Panel Decal Layout	21
Accessories	22
Common Bolt Torque Values	23
Hydraulic Fitting Torque Values	24
Wheel Lug Torque Values.....	24

Splitter Chute Assembly

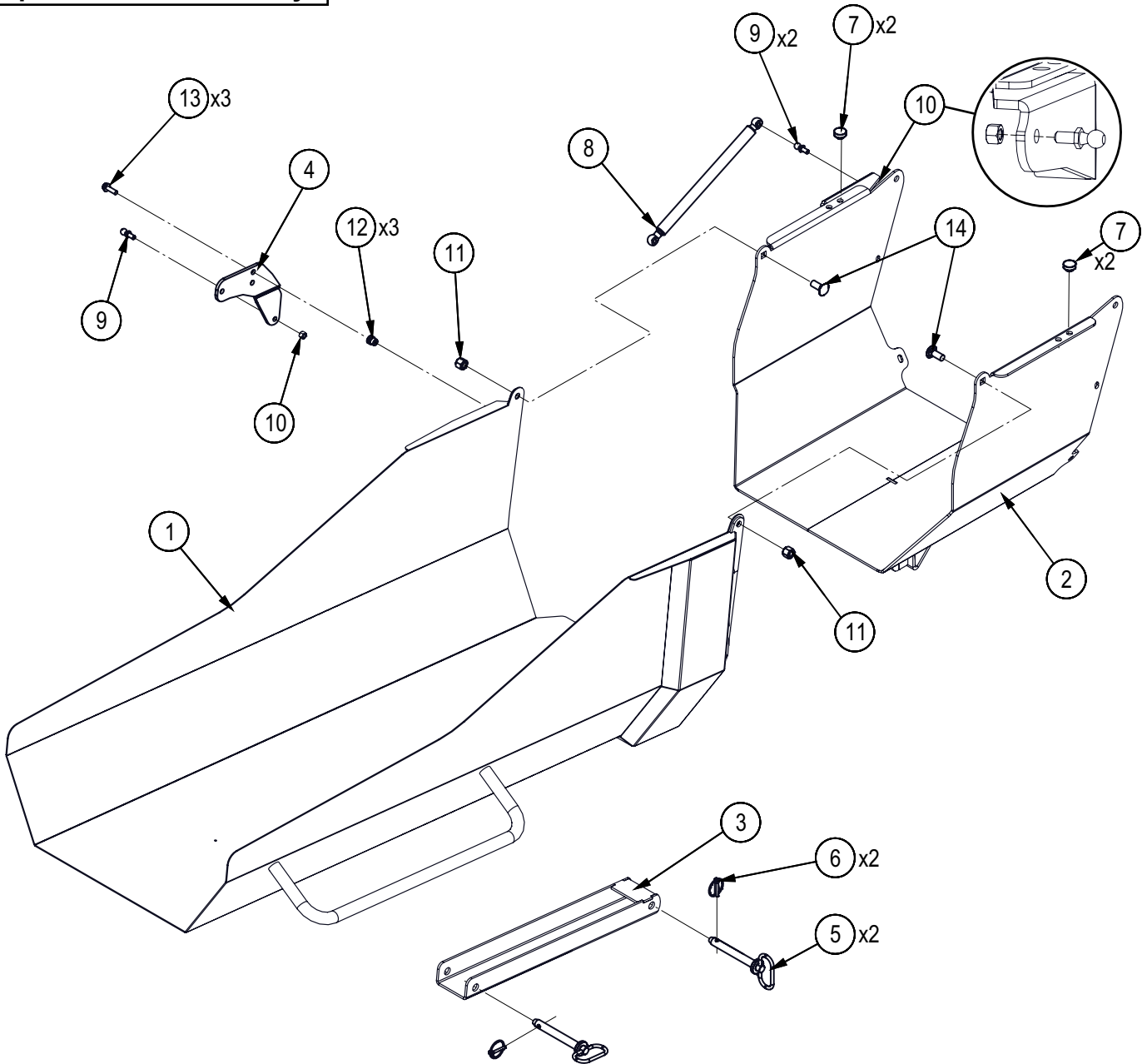

Item No.	Part No.	Description	Qty
1	2251W041	Splitter Chute	1
2	2019W993	Chute, Extension	1
3	2071W114	Chute Adjuster	1
4	2071L188	Plate, Spring Mount	1
5	Z11232	Hitch Pin, 5/8" x 4-1/4"	2
6	Z12110	Lynch Pin, 3/16"	2
7	Z19909	Rubber Bumper, 7/16" x 1"	4
8	Z34203	Gas Spring, 10mm OD x 540mm x 215mm x 158 lbs	1
9	Z34204	Ball Stud, 13mm x 5/16NC	2
10	Z72221	Hex Lock Nut, 5/16NC	2
11	Z72251	Hex Lock Nut, 1/2NC	2
12	Z72956	Rivet Nut, 5/16NC x 150	3
13	Z76125	Flange Bolt, 5/16NC x 1"	3
14	Z76259	Carriage Bolt, 1/2NC x 1-1/4"	2

Lead In Chute Assembly

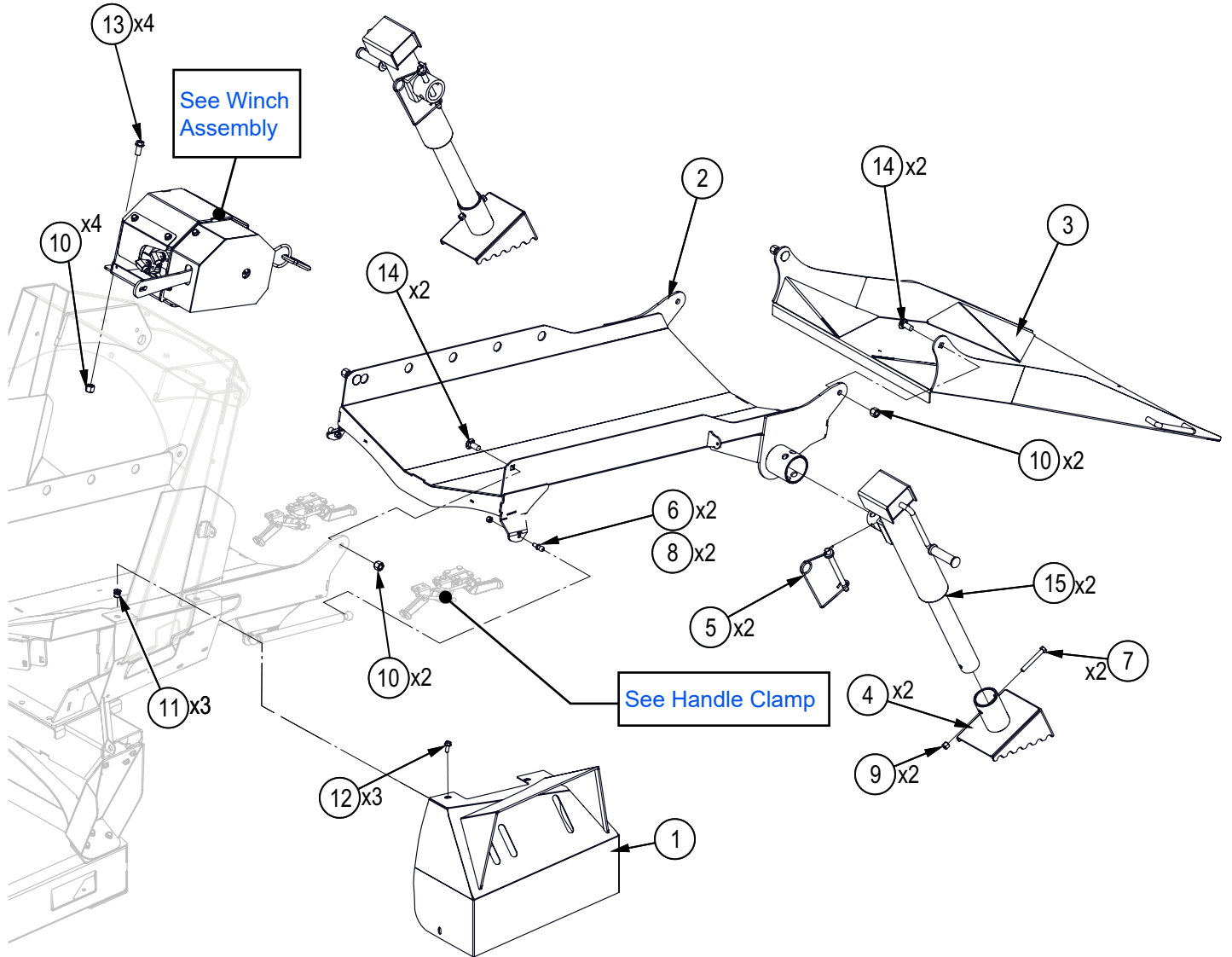

Item No.	Part No.	Description	Qty
1	2210W043	Valve Cover	1
2	2251W016	Chute, Bottom	1
3	2251W017	Chute, Lead In	1
4	2251W020	Foot, Jack	2
5	Z12441	Snap Lock Pin, 1/2" x 4-1/2"	2
6	Z34204	Ball Stud, 13mm x 5/16NC	2
7	Z71330	Hex Bolt, 3/8NC x 3"	2
8	Z72221	Hex Lock Nut, 5/16NC	2
9	Z72231	Hex Lock Nut, 3/8NC	2
10	Z72251	Hex Lock Nut, 1/2NC	8
11	Z72956	Rivet Nut, 5/16NC x 150	3
12	Z76121	Flange Bolt, 5/16NC x 3/4"	3
13	Z76153	Flange Bolt, 1/2NC x 1"	4
14	Z76259	Carriage Bolt, 1/2NC x 1-1/4"	4
15	Z91515	Trailer Jack, Side Wind x 2000lbs No Foot	2

Log Hold Down Assembly

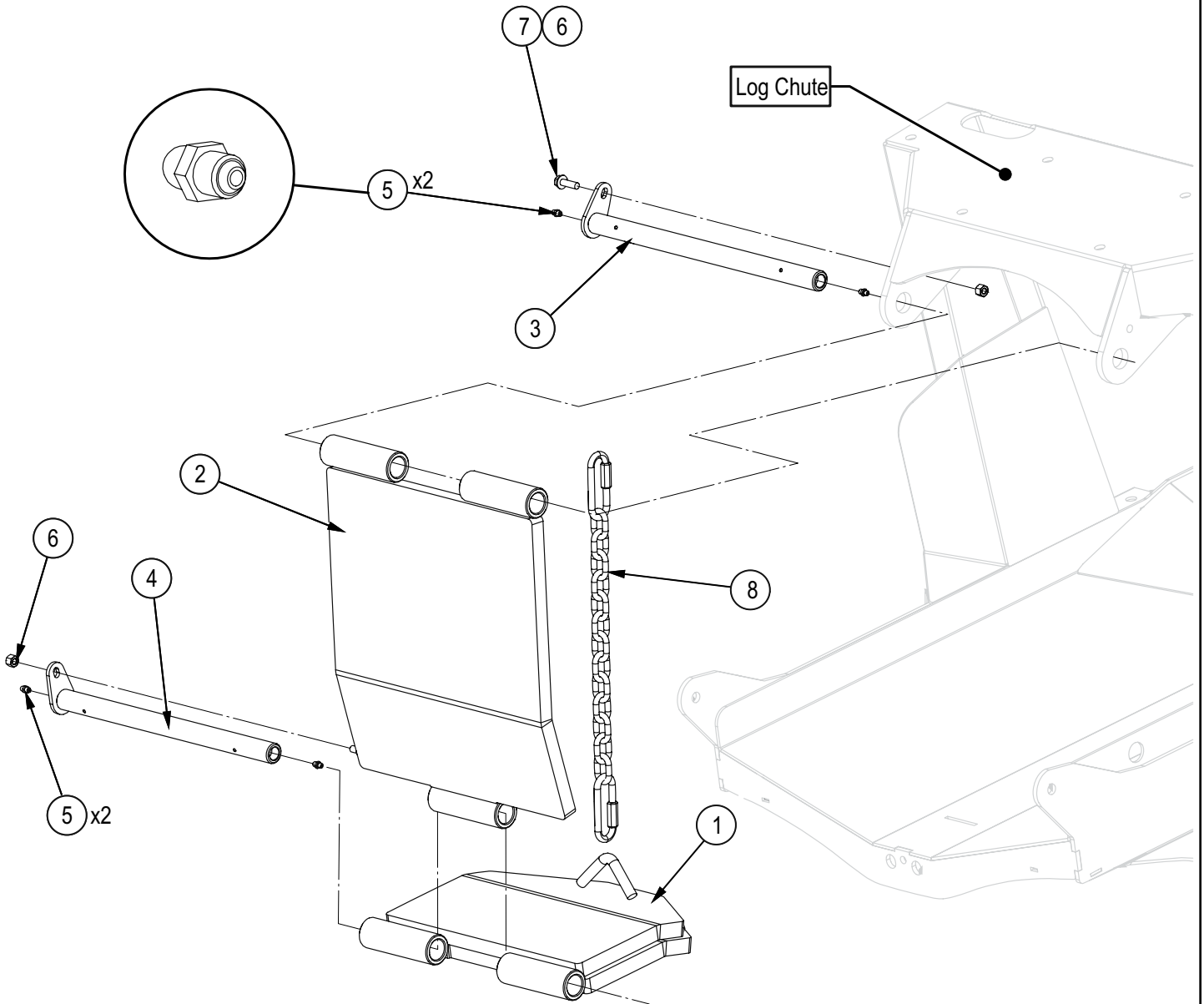

Item No.	Part No.	Description	Qty
1	2071W102	Hold Down Bottom	1
2	2071W110	Log Hold Down Long	1
3	2071W112	Pin, Log Hold Down	1
4	2071W136	Pin, Log Hold Down	1
5	Z29202	Grease Fitting, 1/4NF	4
6	Z72221	Hex Lock Nut, 5/16NC	2
7	Z76125	Flange Bolt, 5/16NC x 1"	1
8	Z92311	Chain, 1/4" x 21" with Two Quicklinks	1

Splitter Main Frame Assembly

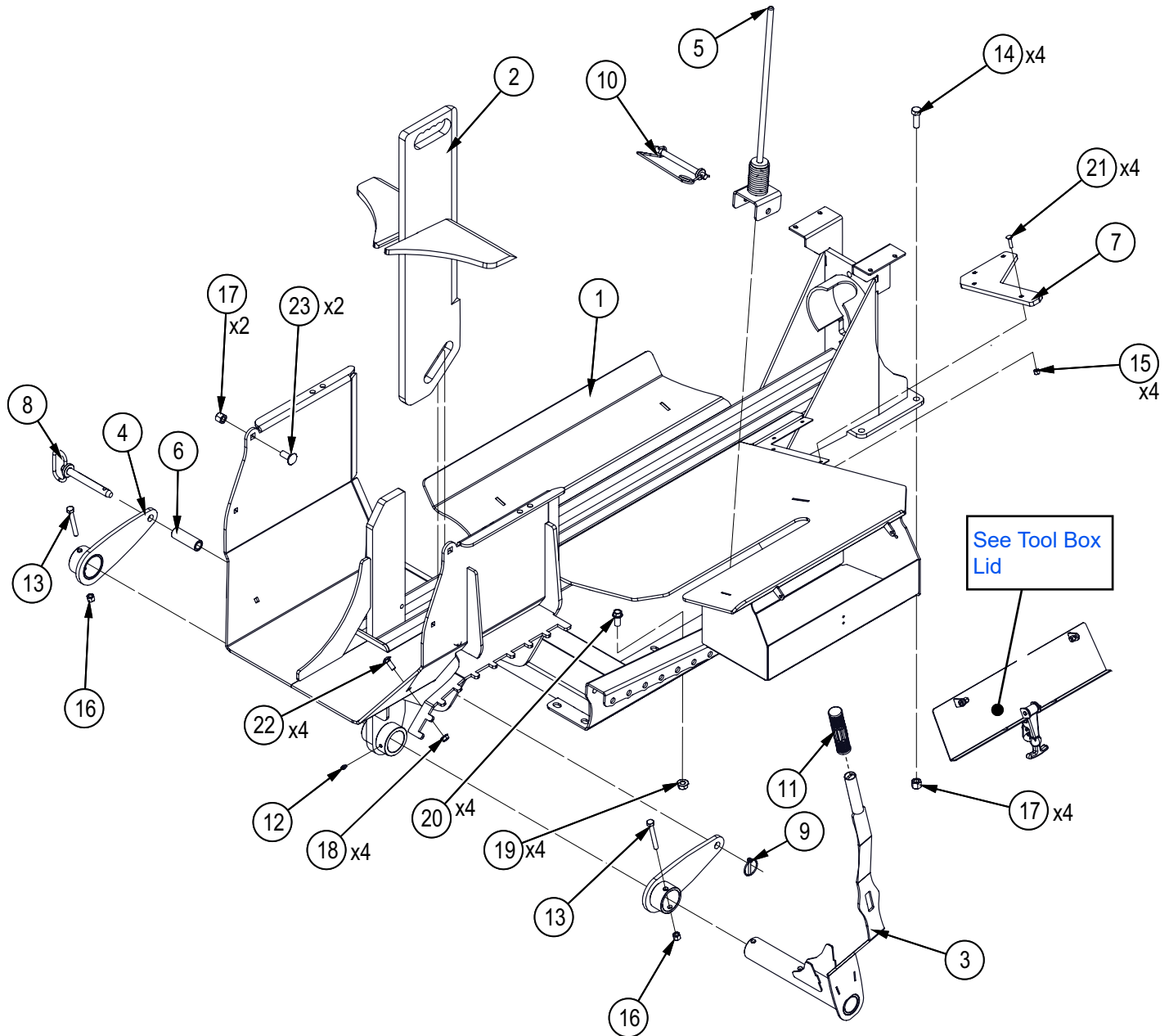

Item No.	Part Number	Description	Qty
1	2210W530	Main Frame 36" 3PH	1
2	2071W532	Wedge 4 Way	1
3	2071W533	Wedge Position Handle	1
4	2071W111	Arm Wedge Lifter	2
5	2071W190	Log Stop Whip	1
6	2071M123	Roller Wedge Lift	1
7	2251S002	Edge, Log Table Long	1
8	Z11232	Hitch Pin, 5/8" x 4-1/4"	1
9	Z12110	Lynch Pin, 3/16"	1
10	Z12441	Snap Lock Pin, 1/2" x 4-1/2"	1
11	Z19321	Handle Grip, 1"	1
12	Z29202	Grease Fitting, 1/4NF	1

Item No.	Part Number	Description	Qty
13	Z71330	Hex Bolt, 3/8NC x 3"	2
14	Z71515	Hex Bolt, 1/2NC x 1-1/2"	4
15	Z72211	Hex Lock Nut, 1/4NC	4
16	Z72231	Hex Lock Nut, 3/8NC	2
17	Z72251	Hex Lock Nut, 1/2NC	6
18	Z72531	Serrated Flange Locknut, 3/8NC	4
19	Z72551	Serrated Flange Locknut, 1/2NC	4
20	Z76153	Flange Bolt, 1/2NC x 1"	4
21	Z76212	Carriage Bolt, 1/4NC x 1"	4
22	Z76231	Carriage Bolt, 3/8NC x 1"	4
23	Z76259	Carriage Bolt, 1/2NC x 1-1/4"	2

Log Chute Assembly

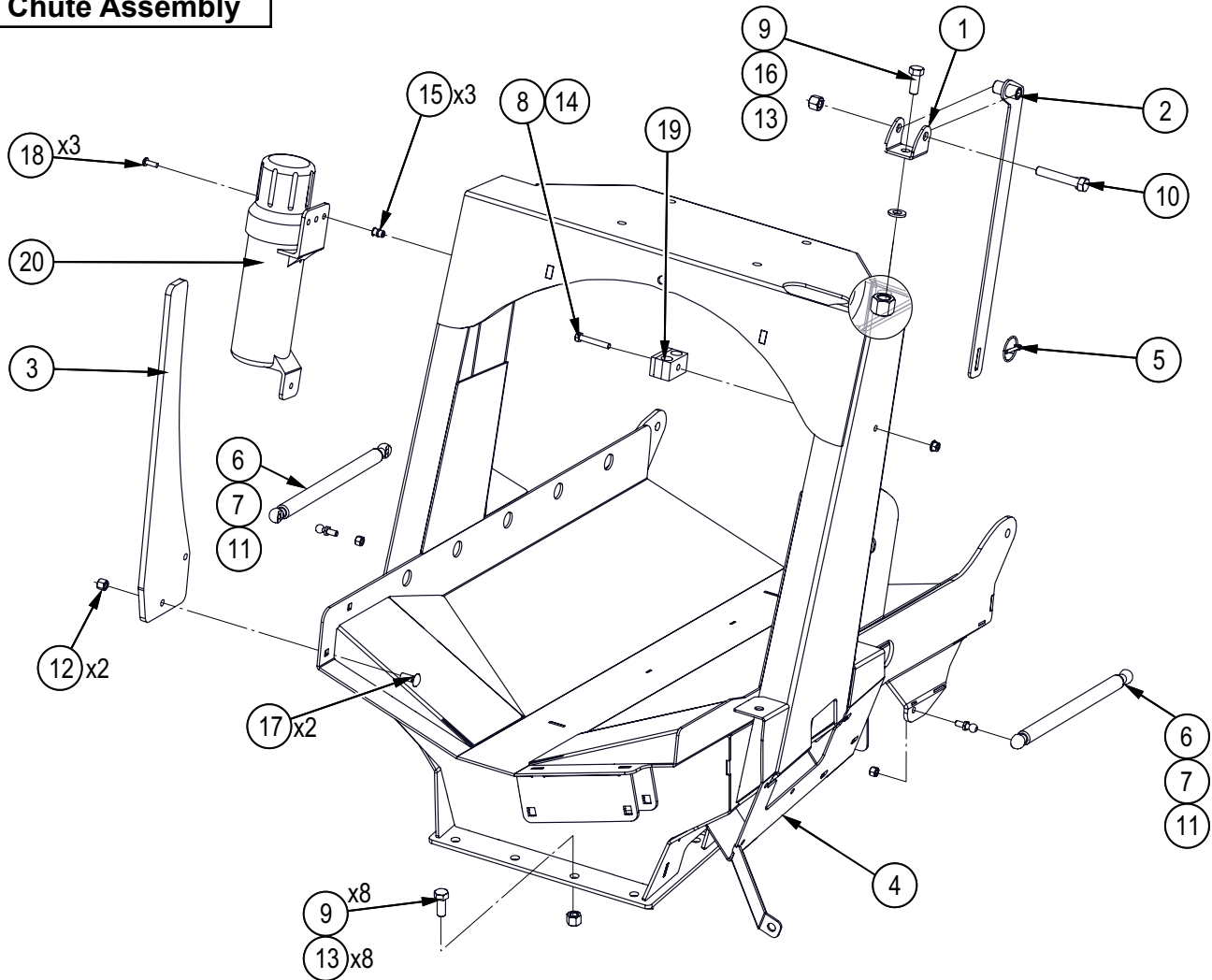

Item No.	Part Number	Description	Qty
1	2071L123	Clevis, Latch Mount	1
2	2071W121	Arm,Log Chute Lock	1
3	2251S003	Saw Guide	1
4	2251W015	Chute, Log	1
5	Z12110	Lynch Pin, 3/16"	1
6	Z34203	Gas Spring, 10mm OD x 540mm x 215mm x 158 lbs	2
7	Z34204	Ball Stud, 13mm x 5/16NC	2
8	Z71220	Hex Bolt, 5/16NC x 2"	1
9	Z71512	Hex Bolt, 1/2NC x 1-1/4"	9
10	Z71530	Hex Bolt, 1/2NC x 3"	1
11	Z72221	Hex Lock Nut, 5/16NC	2
12	Z72231	Hex Lock Nut, 3/8NC	2
13	Z72251	Hex Lock Nut, 1/2NC	10
14	Z72521	Serrated Flange Locknut, 5/16NC	1
15	Z72962	Rivet Nut, 1/4NC x 260	3
16	Z73151	SAE Washer, 1/2"	1
17	Z76231	Carriage Bolt, 3/8NC x 1"	2
18	Z78301	Machine Screw, 1/4NC x 3/4"	3
19	Z79463	Double Hose Clamp, 11/16" OD	1
20	Z96503	Manual Tube, 3-1/2" Short	1

Three Point Hitch Frame Assembly

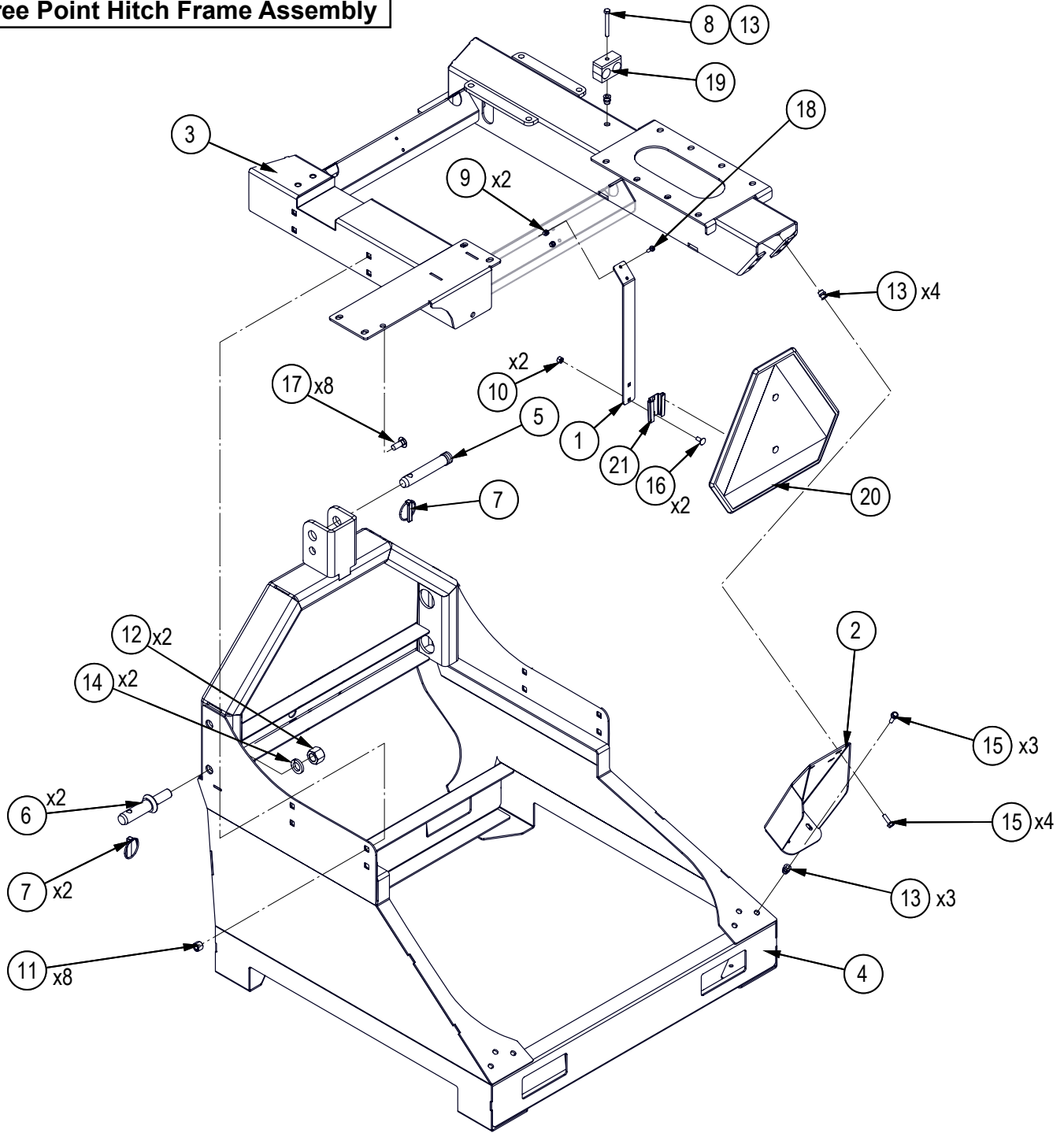

Item No.	Part No.	Description	Qty
1	2019L922	SMV Post	1
2	2210L015	Brace, 3PH	1
3	2210W001	WP 3PH Frame Adapter	1
4	2210W002	WP 3PH Base	1
5	Z11142	Toplink Pin, 1" x 4-5/16"	1
6	Z11442	Implement Pin, 1-1/8" x 2-1/4" x 7/8NF	2
7	Z12140	Lynch Pin, 7/16"	3
8	Z71227	Hex Bolt, 5/16NC x 2-3/4"	1
9	Z72211	Hex Lock Nut, 1/4NC	2
10	Z72221	Hex Lock Nut, 5/16NC	2
11	Z72251	Hex Lock Nut, 1/2NC	8
12	Z72282	Hex Lock Nut, 7/8NF	2

Item No.	Part No.	Description	Qty
13	Z72957	Rivet Nut, 5/16NC x 312	8
14	Z73381	Split Lock Washer, 7/8"	2
15	Z76125	Flange Bolt, 5/16NC x 1"	7
16	Z76221	Carriage Bolt, 5/16NC x 3/4"	2
17	Z76259	Carriage Bolt, 1/2NC x 1-1/4"	8
18	Z78301	Machine Screw, 1/4NC x 3/4"	2
19	Z79465	Double Hose Clamp, 1-1/16" OD	1
20	Z96605	SMV Sign With Spade, Assembled	1
21	Z96603	SMV Socket	1

ECR03535

Hydraulic Splitter Assembly

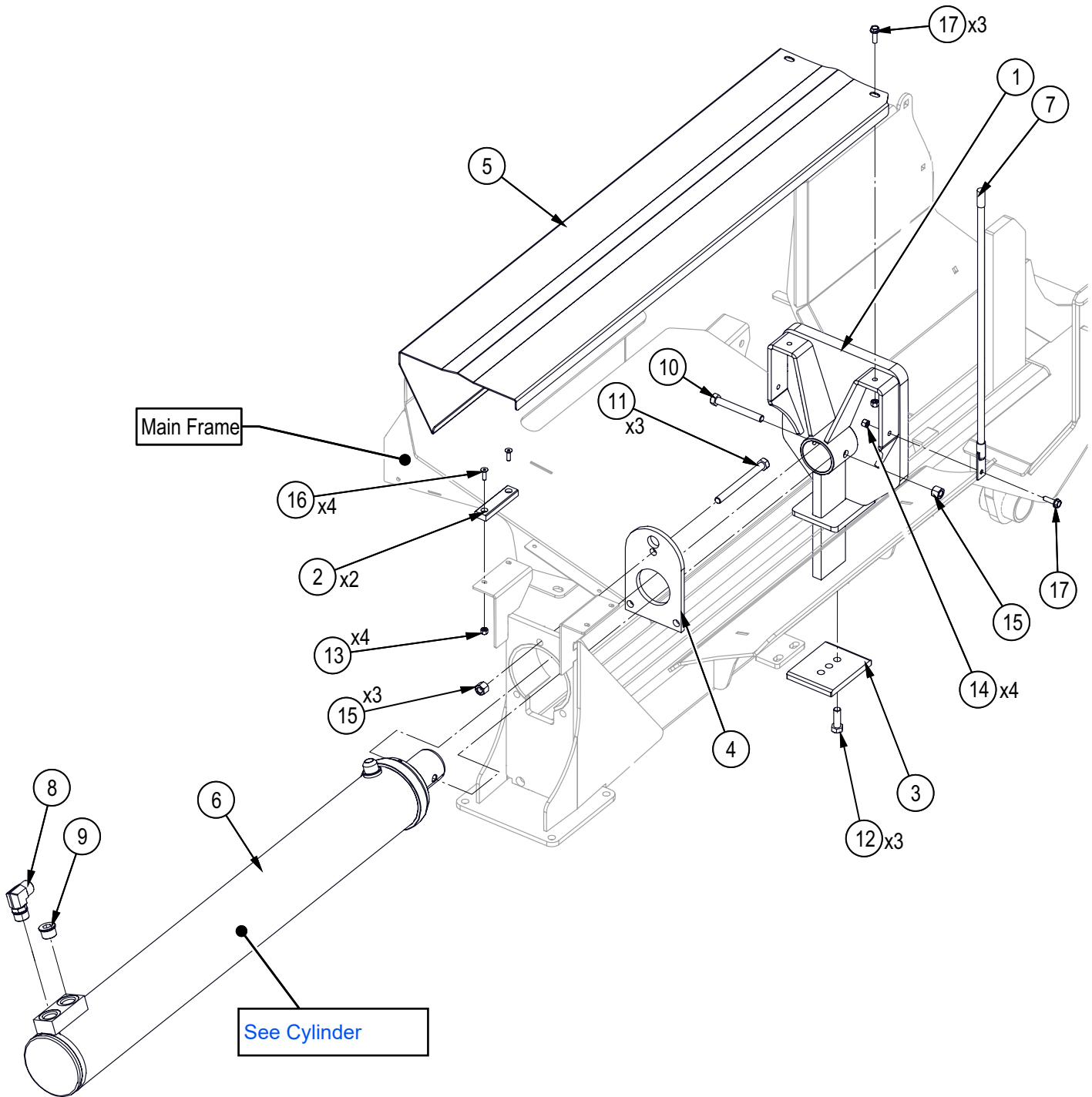

Item No.	Part Number	Description	Qty
1	2251W038	Hvy Push Block	1
2	1022S208	Rotor Hood Slide	2
3	2055S517	Cap, Push Block	1
4	2071L215	Plate, Cylinder Retaining	1
5	2251L509	Cover, Sliding	1
6	2251C501	Cylinder, 4-1/2" x 37.750"	1
7	Z19908	Blade Guide, 1/2" x 24"	1
8	Z516501	Elbow 90, MJIC x MORB 1212	1
9	Z51695	Socket Plug, MORB 12	1

Item No.	Part Number	Description	Qty
10	Z71540	Hex Bolt, 1/2NC x 4"	1
11	Z71555	Hex Bolt, 1/2NC x 5-1/2"	3
12	Z71576G8	Hex Bolt, 1/2NF x 1-1/2" G8	3
13	Z72211	Hex Lock Nut, 1/4NC	4
14	Z72221	Hex Lock Nut, 5/16NC	4
15	Z72251	Hex Lock Nut, 1/2NC	4
16	Z75211	FHCS, 1/4NC x 7/8"	4
17	Z76125	Flange Bolt, 5/16NC x 1"	4

Hydraulic Winch

Note: Replacement winch gears should be ordered in sets. Order:
 #5081M125 Gear Driven
 #5081M126 Drive Gear Hub

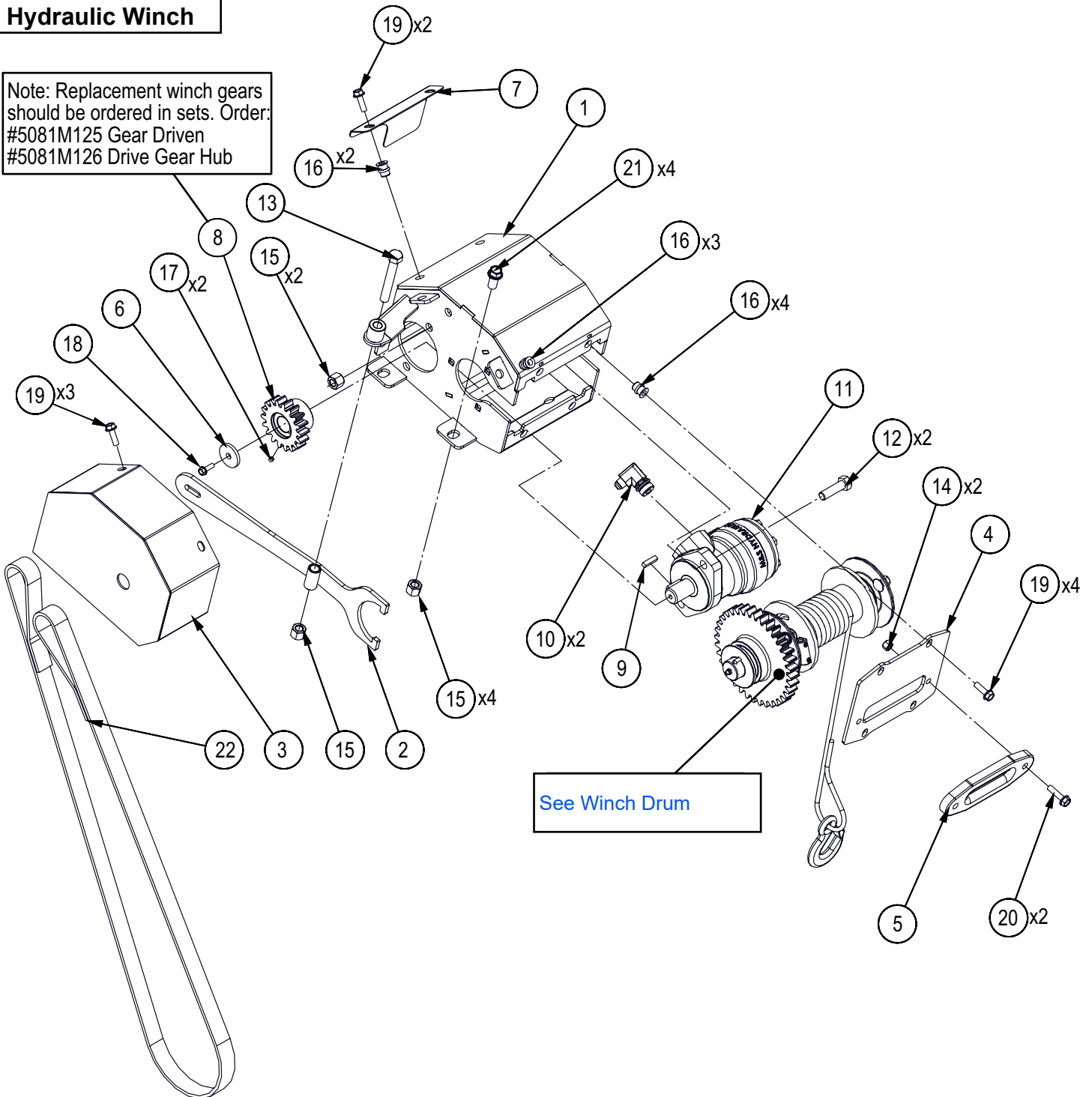

Item No.	Part No.	Description	Qty
1	2251W018	Housing, Winch	1
2	5081W122	Handle, Winch Clutch	1
3	5081W111	Shield	1
4	2251L071	Mount, Hawse Fairlead	1
5	2251M003	Synthetic Fairlead	1
6	5081L114	Washer, Motor Shaft	1
7	5081L138	Guard	1
8	5081M126	Drive Gear Hub	1
9	Z46533	Key, 1/4" x 1/4" x 1"	1
10	Z51656	Elbow 90, MJIC x MORB 0610	2
11	Z54109	Hydraulic Motor, 100CCR	1
12	Z71517	Hex Bolt, 1/2NC x 1-3/4"	2

Item No.	Part No.	Description	Qty
13	Z71535	Hex Bolt, 1/2NC x 3-1/2"	1
14	Z72221	Hex Lock Nut, 5/16NC	2
15	Z72251	Hex Lock Nut, 1/2NC	7
16	Z72957	Rivet Nut, 5/16NC x 312	9
17	Z74111	Set Screw, 1/4NC x 1/4"	2
18	Z76111	Flange Bolt, 1/4NC x 3/4"	1
19	Z76125	Flange Bolt, 5/16NC x 1"	9
20	Z76128	Flange Bolt, 5/16NC x 1-1/4"	2
21	Z76153	Flange Bolt, 1/2NC x 1"	4
22	Z92405	Winching Strap, 1" x 5ft	1

Winch Drum

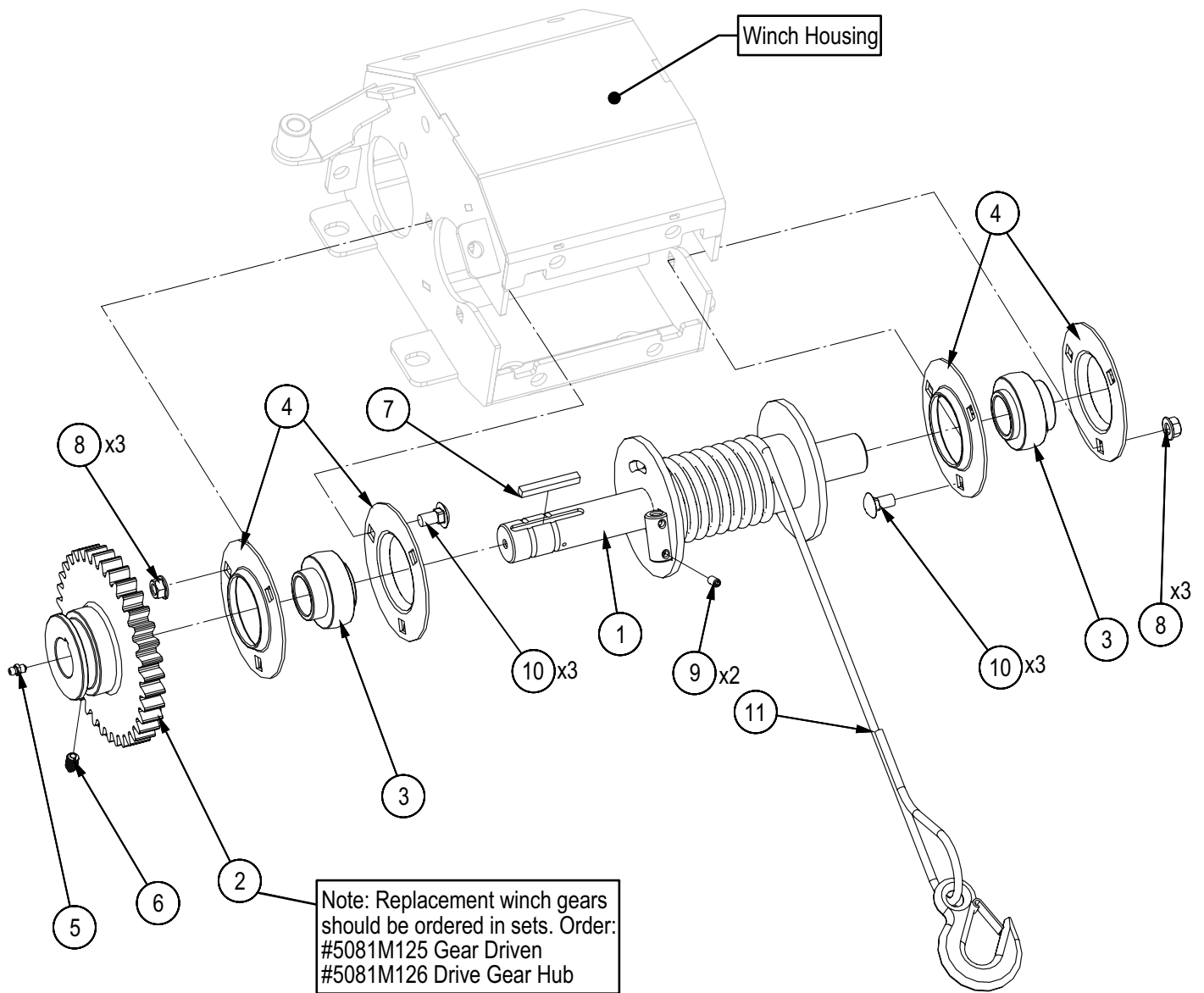

Item No.	Part No.	Description	Qty
1	2251W019	Drum, Main Cable	1
2	5081M125	Gear, Driven	1
3	Z25207	Bearing Insert, UC206-20	2
4	Z25301	3-Bolt Flange Bearing, PF206 x Flange Only	4
5	Z29202	Grease Fitting, 1/4NF	1
6	Z34302	Spring Plunger, 3/8NC x 5/8" x 21 lbs	1
7	Z46531	Key, 1/4" x 1/4" x 2"	1
8	Z72531	Serrated Flange Locknut, 3/8NC	6
9	Z74113	Set Screw, 1/4NC x 1/2"	2
10	Z76233	Carriage Bolt, 3/8NC x 3/4"	6
11	Z92112	Synthetic Winch Rope, 1/4 x 50ft with Grab Hook	1

Tool Box Lid

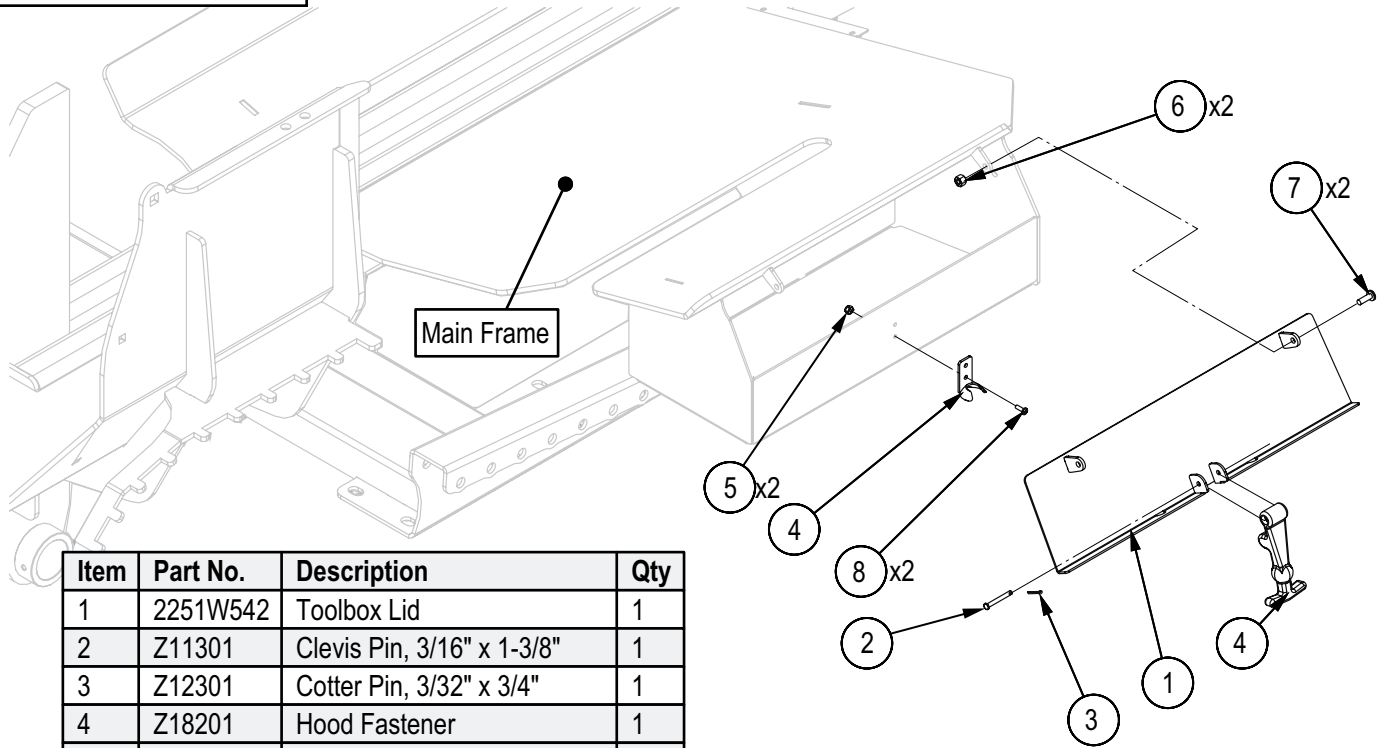

Item	Part No.	Description	Qty
1	2251W542	Toolbox Lid	1
2	Z11301	Clevis Pin, 3/16" x 1-3/8"	1
3	Z12301	Cotter Pin, 3/32" x 3/4"	1
4	Z18201	Hood Fastener	1
5	Z72202	Hex Lock Nut, #8NC	2
6	Z72211	Hex Lock Nut, 1/4NC	2
7	Z78301	Machine Screw, 1/4NC x 3/4"	2
8	Z78309	Machine Screw, #8NC x 1/2"	2

Handle Clamp

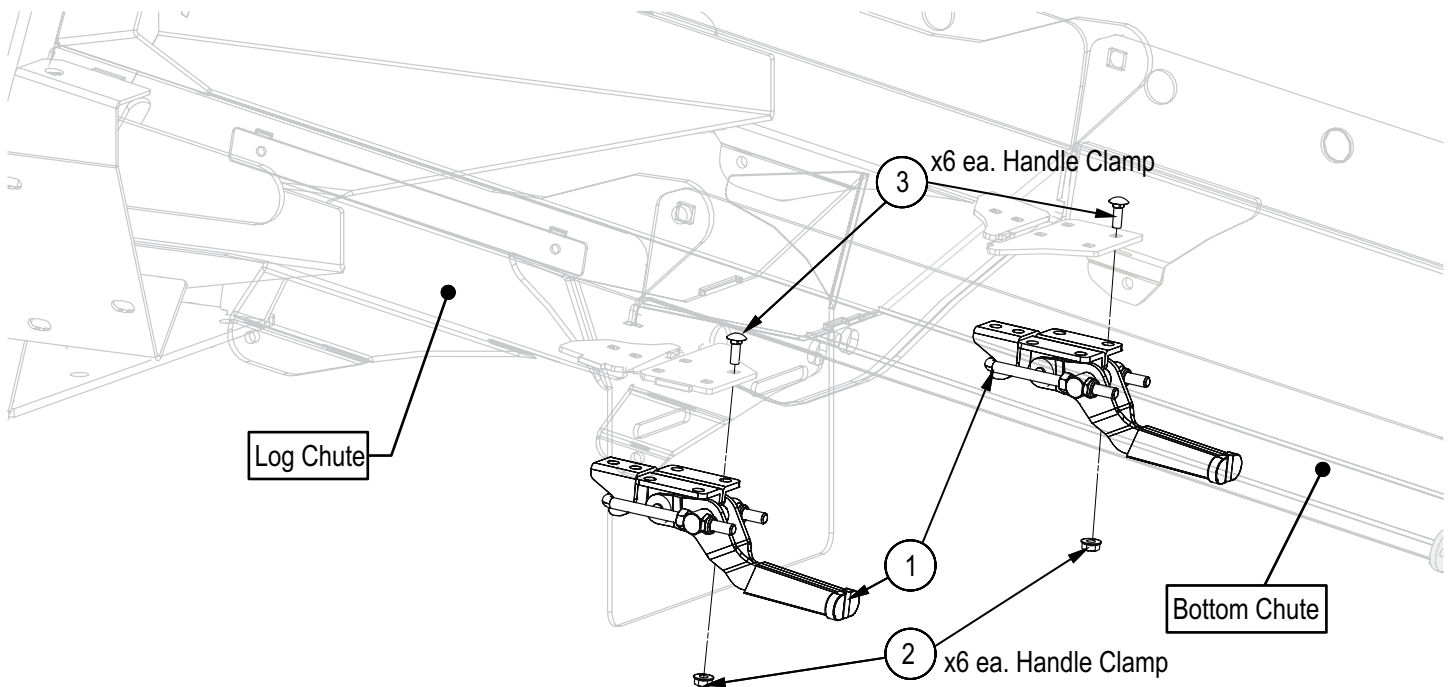

Item No.	Part No.	Description	Qty
1	Z19511	Handle Clamp, Latch Type x 2-Piece	2
2	Z72511	Serrated Flange Locknut, 1/4NC	12
3	Z76211	Carriage Bolt, 1/4NC x 3/4"	12

Cylinder

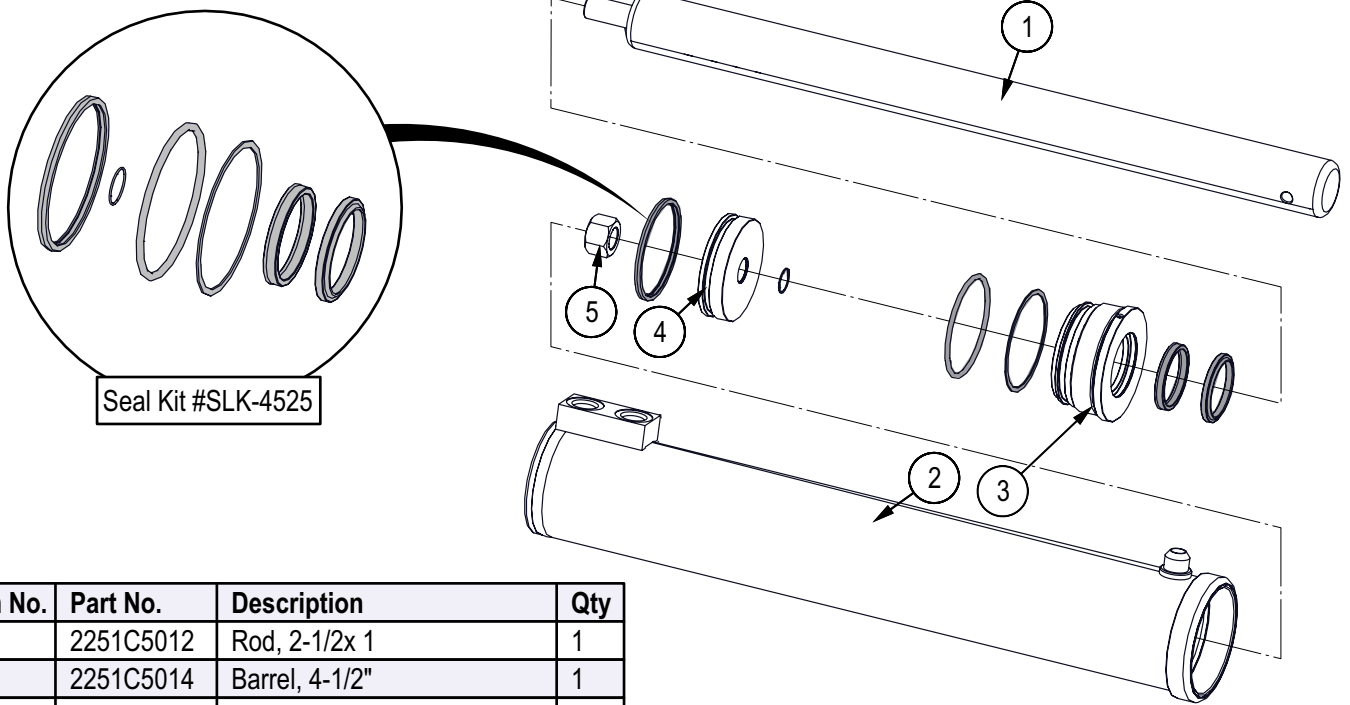

Seal Kit #SLK-4525

Item No.	Part No.	Description	Qty
1	2251C5012	Rod, 2-1/2x 1	1
2	2251C5014	Barrel, 4-1/2"	1
3	G450-250S	Gland, 4-1/2" x 2-1/2"	1
4	P100-450SP	Piston, 4-1/2" Bore	1
5	Z722909G8	Hex Top-lock Nut, 1-14NF G8	1

License Lamp

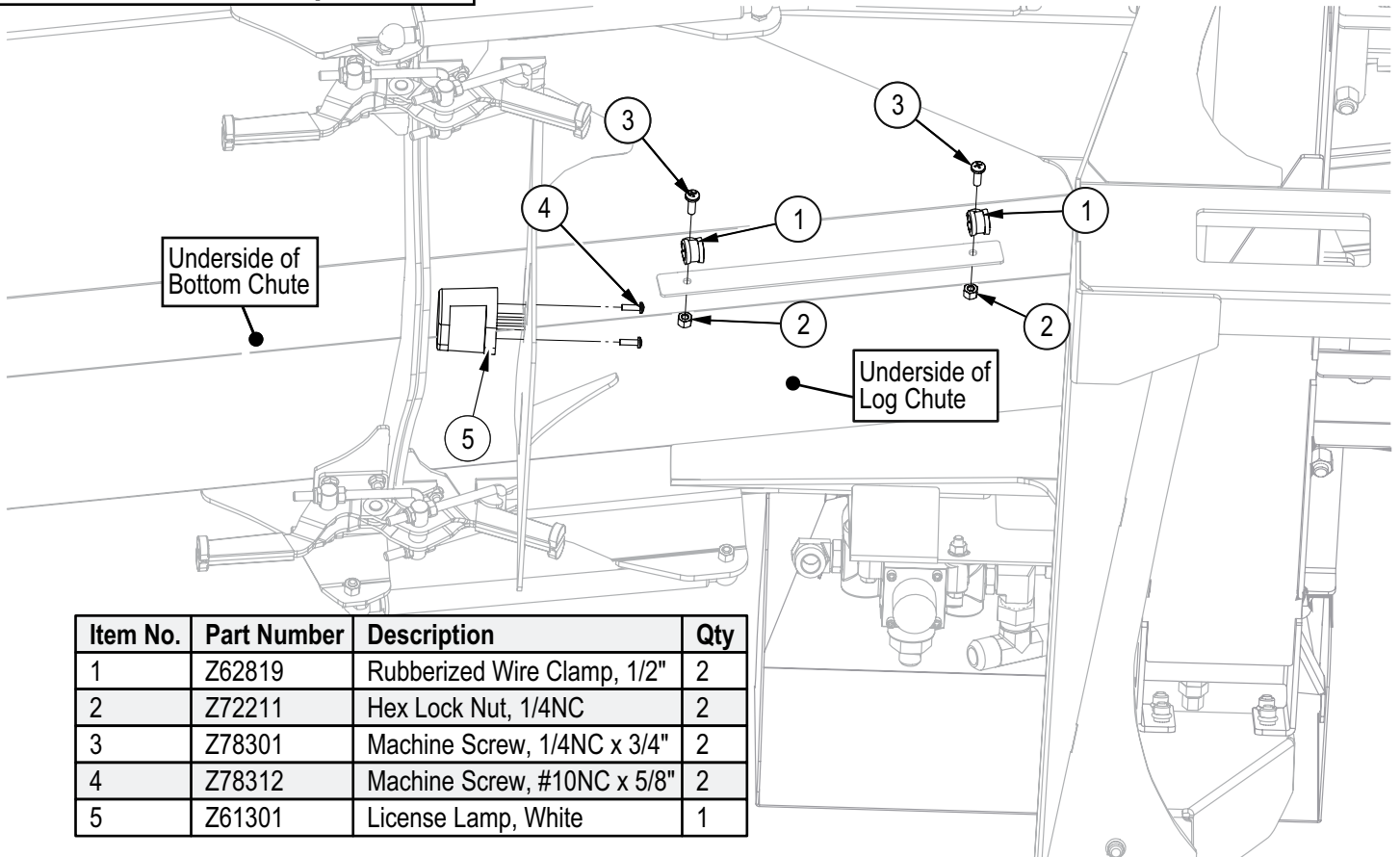

Underside of Bottom Chute

Underside of Log Chute

Item No.	Part Number	Description	Qty
1	Z62819	Rubberized Wire Clamp, 1/2"	2
2	Z72211	Hex Lock Nut, 1/4NC	2
3	Z78301	Machine Screw, 1/4NC x 3/4"	2
4	Z78312	Machine Screw, #10NC x 5/8"	2
5	Z61301	License Lamp, White	1

Valve Assembly

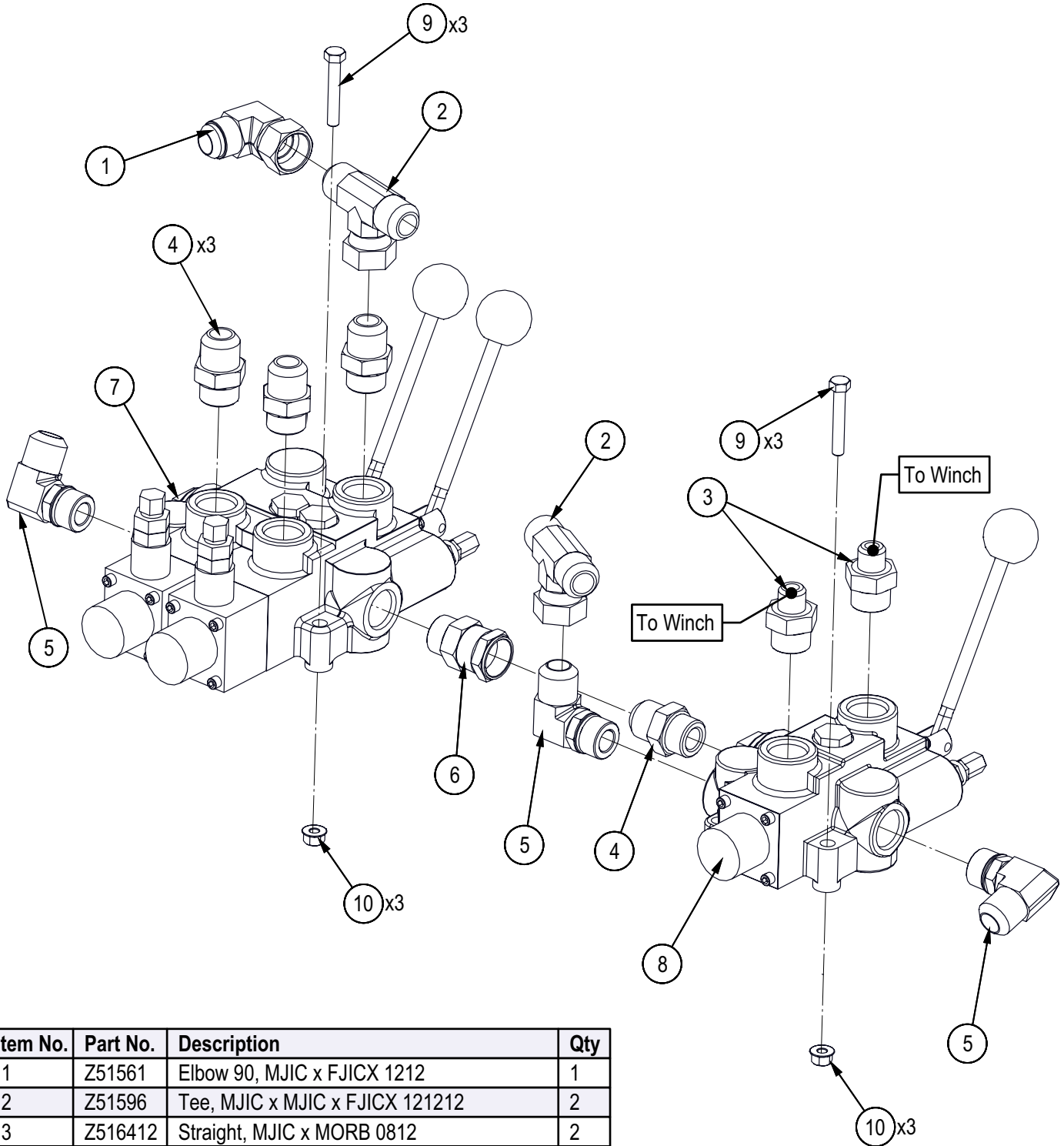

Item No.	Part No.	Description	Qty
1	Z51561	Elbow 90, MJIC x FJICX 1212	1
2	Z51596	Tee, MJIC x MJIC x FJICX 121212	2
3	Z516412	Straight, MJIC x MORB 0812	2
4	Z516414	Straight, MJIC x MORB 1212	4
5	Z516501	Elbow 90, MJIC x MORB 1212	3
6	Z51764	Straight, MORB x FJICX 1212	1
7	Z56213	Auto-Cycle Valve, OC x 25GPM	1
8	Z56224	Single Spool Valve, PB Tandem SC x 30GPM	1
9	Z71220	Hex Bolt, 5/16NC x 2"	6
10	Z72521	Serrated Flange Locknut, 5/16NC	6

Closed Center Plug

For tractors with a closed-center hydraulic circuit.

Replace port plug in the main control valve with item 1.

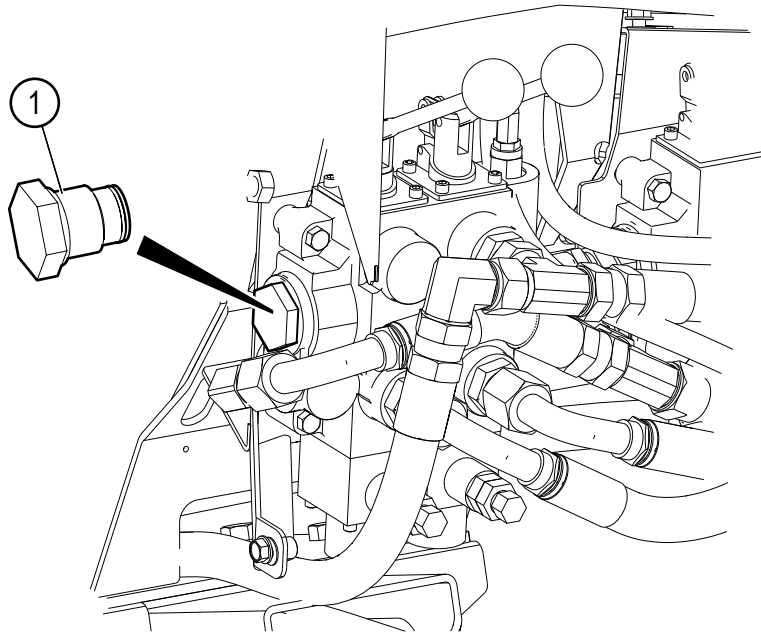

Item No.	Part No.	Description	Qty
1	Z56917	Plug, Closed Center	1

Hydraulic Circuit

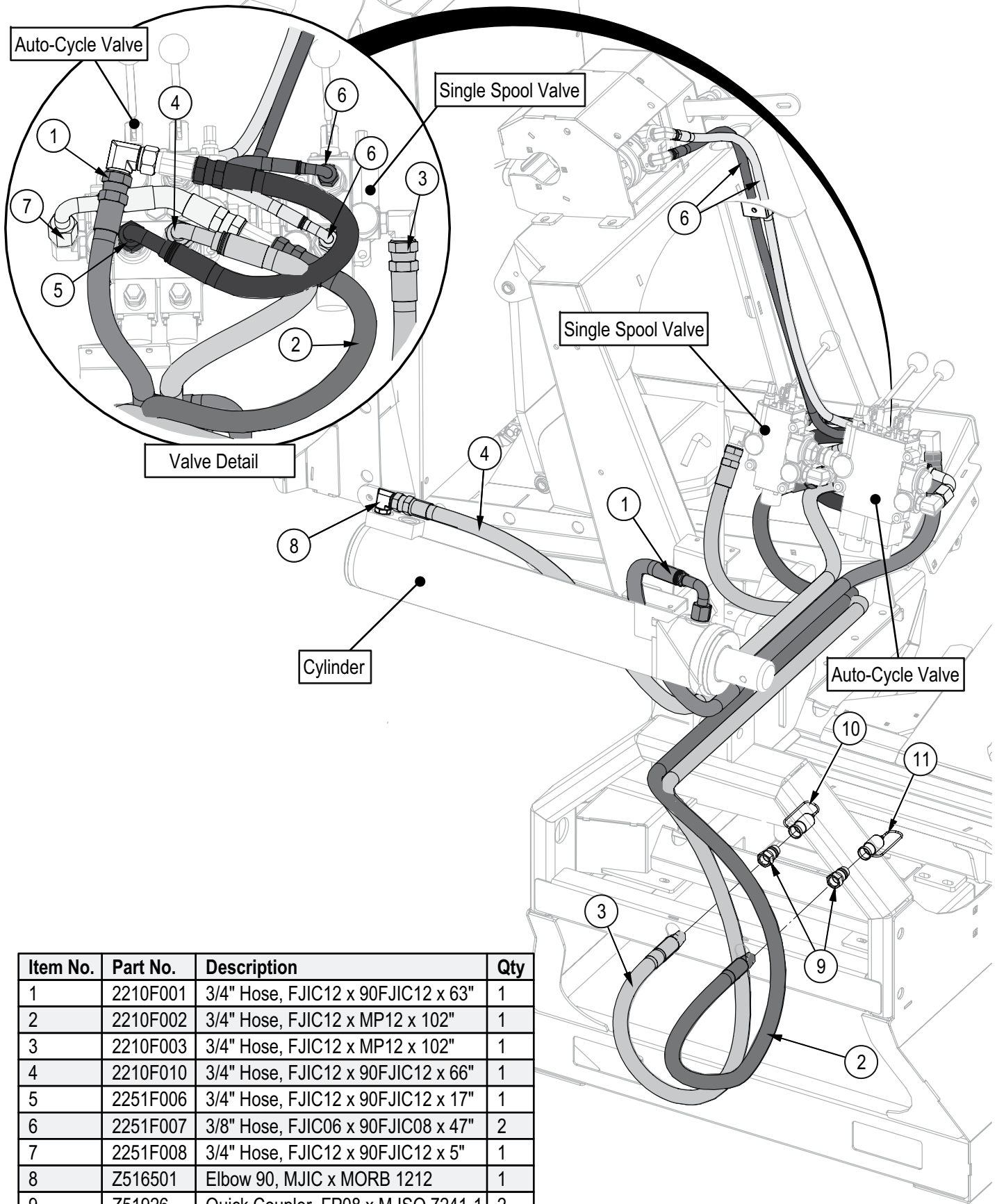

Item No.	Part No.	Description	Qty
1	2210F001	3/4" Hose, FJIC12 x 90FJIC12 x 63"	1
2	2210F002	3/4" Hose, FJIC12 x MP12 x 102"	1
3	2210F003	3/4" Hose, FJIC12 x MP12 x 102"	1
4	2210F010	3/4" Hose, FJIC12 x 90FJIC12 x 66"	1
5	2251F006	3/4" Hose, FJIC12 x 90FJIC12 x 17"	1
6	2251F007	3/8" Hose, FJIC06 x 90FJIC08 x 47"	2
7	2251F008	3/4" Hose, FJIC12 x 90FJIC12 x 5"	1
8	Z516501	Elbow 90, MJIC x MORB 1212	1
9	Z51926	Quick Coupler, FP08 x M ISO 7241-1	2
10	Z52831	Nipple Cap, ISO 7241-1 x Red	1
11	Z52832	Nipple Cap, ISO 7241-1 x Black	1

Decal Layout

IMPORTANT! If parts are replaced that have safety signs on them, new signs must be applied. Safety signs must always be replaced if they become damaged, are removed, or become illegible.

Safety signs are included in the product decal kit available from your authorized dealer. Decals are not available separately.

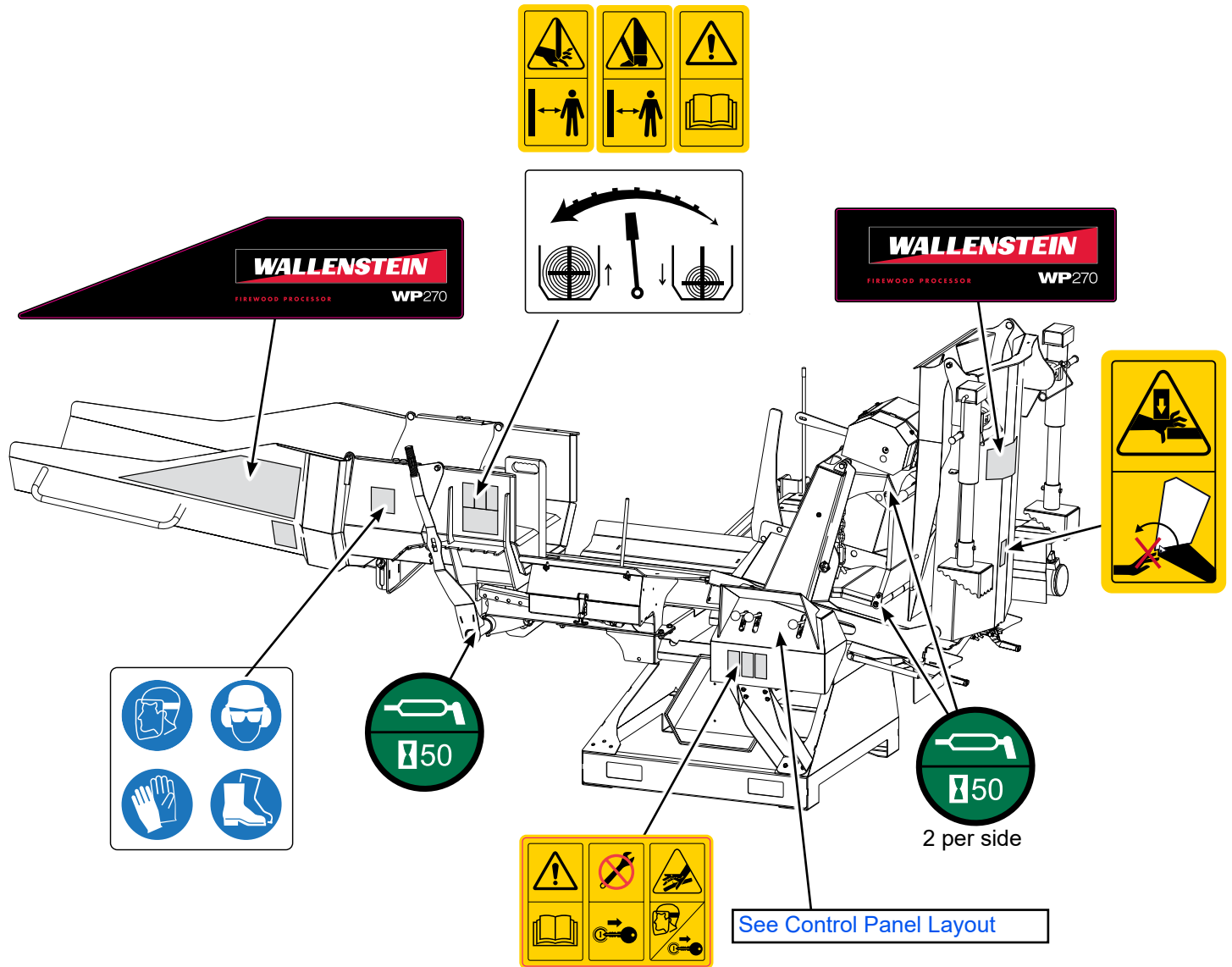

Decal Layout

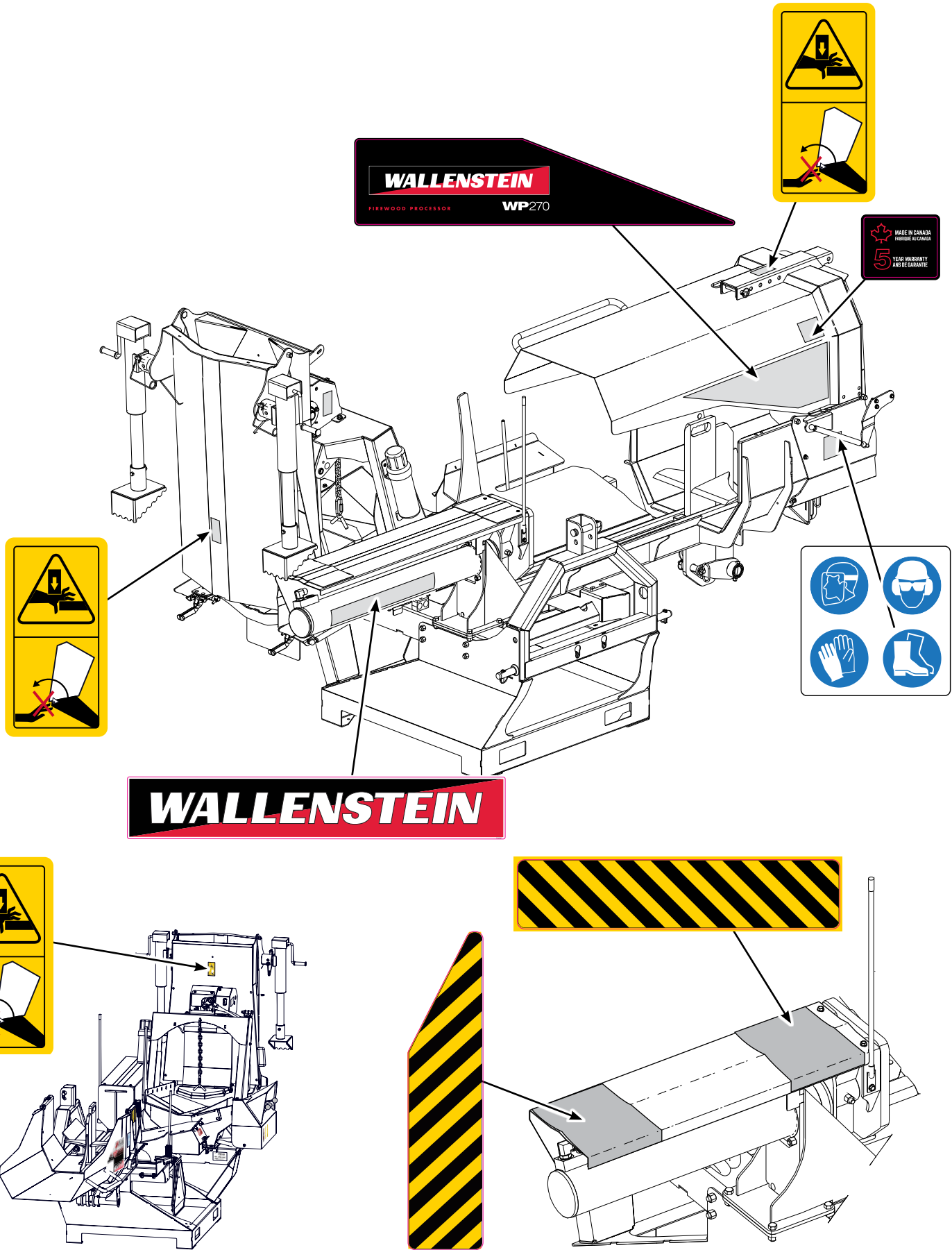

Decal Layout

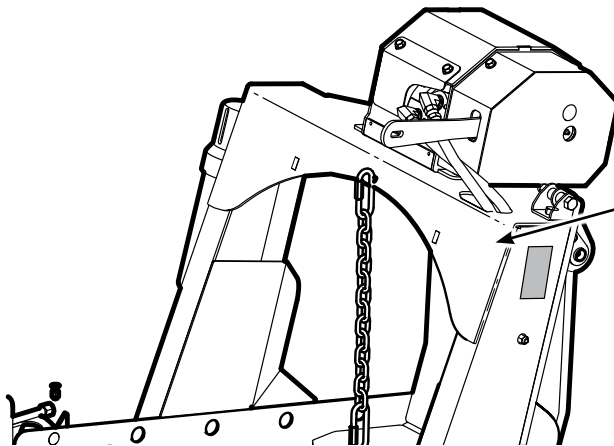
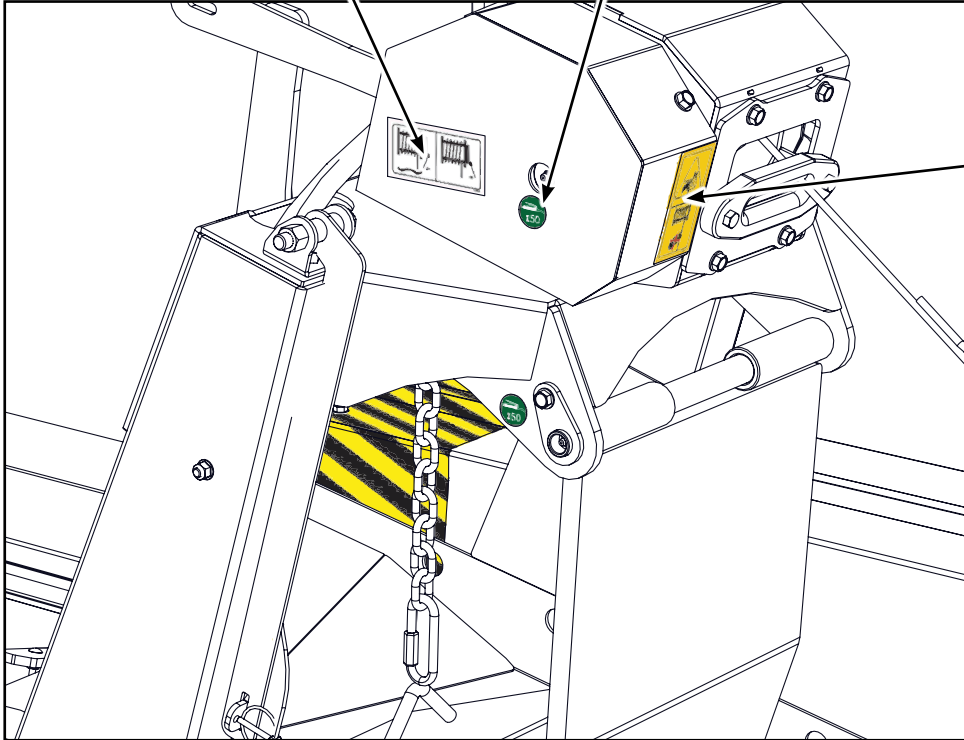
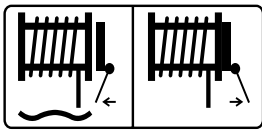

Control Panel Decal Layout

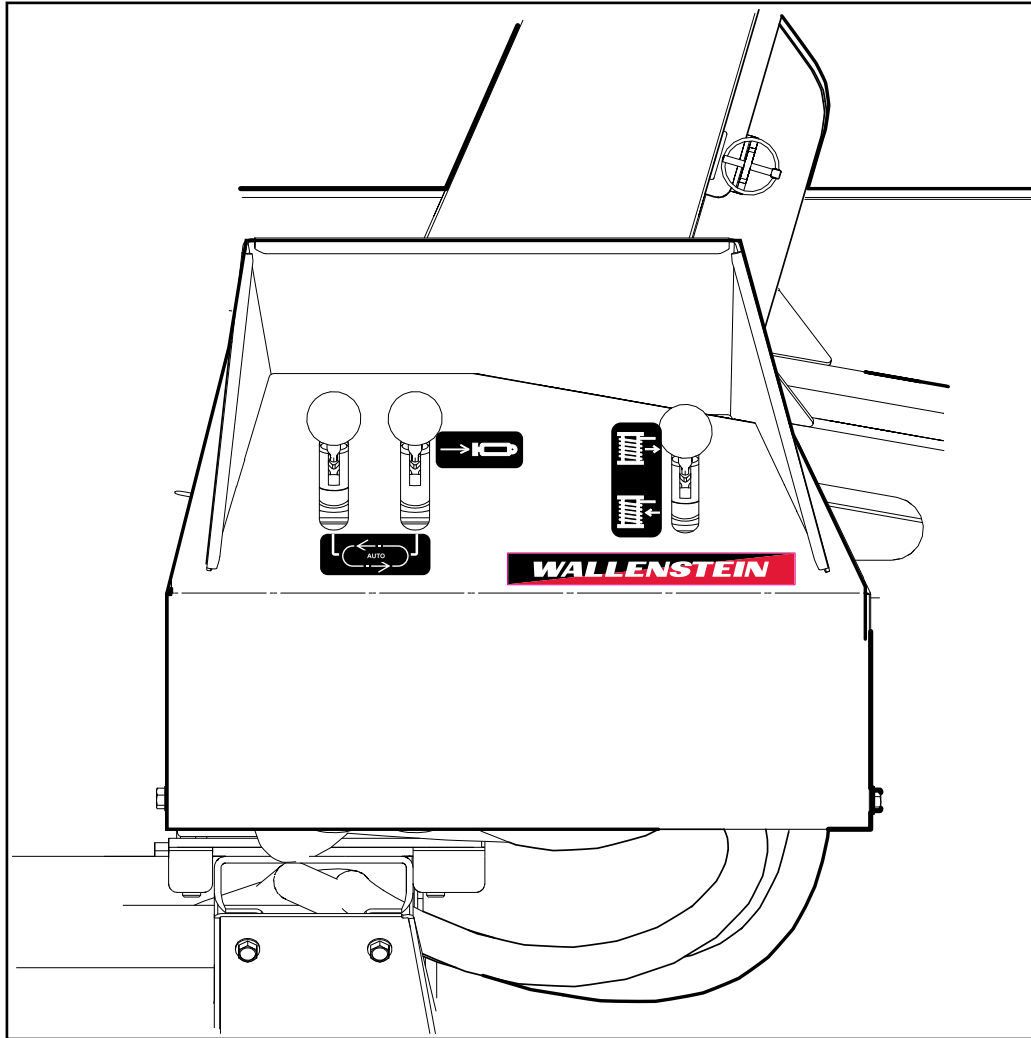

Accessories

Call your dealer for pricing and availability

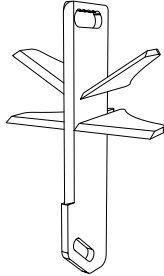
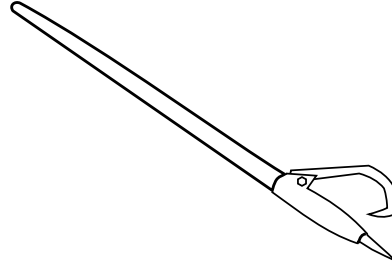
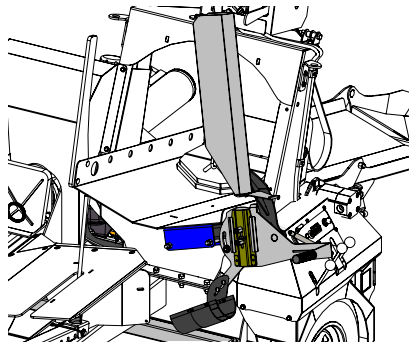
	<p>NYLON CHAINSAW HOLSTER P/N 2089A570</p> <p>For models: WP835EU, WP865EU easy to install, fastens to Wood Processor</p> <p>Nylon holder, safely holds your chainsaw keeping it off the ground and out of the way!</p>
	<p>6-WAY WEDGE – P/N 2089W572</p> <p>Easy to install in minutes, and you're ready to go!</p> <p>6 way splitting wedge, Boost your productivity and make quick work out of chunks by splitting into six pieces at once. This is an ideal way to save time</p>
	<p>48" LOG PEAVEY P/N Z99001</p> <p>Helps to move those heavy log timbers into position, and finish getting your last logs through the Wood Processor!</p>
	<p>PIVOTING CHAINSAW HOLDER P/N P201</p> <p>For all WP Series</p> <p>Easy mounting to most chain saws, the pivoting chain saw holder securely holds your saw in place allowing for easier cutting and saving time handling your chainsaw.</p> <div style="border: 1px solid black; padding: 5px; margin-top: 10px;"> <p>Available: P211 Spare Pivoting Chainsaw Adaptor Save time switching out chainsaws with a spare adaptor for your second chainsaw!</p> </div>

Common Bolt Torque Values

Checking Bolt Torque

The tables shown give correct torque values for various bolts and capscrews. Tighten all bolts to the torque values specified in the table, unless indicated otherwise. Check tightness of bolts periodically.

IMPORTANT! If replacing hardware, use fasteners of the same grade.

IMPORTANT! Torque figures indicated in the table are for non-greased or non-oiled threads. Do not grease or oil threads unless indicated otherwise. When using a thread locker, increase torque values by 5%.

 **NOTE:** Bolt grades are identified by their head markings.

Imperial Bolt Torque Specifications						
Bolt Diameter	Torque Value					
	SAE Gr. 2		SAE Gr. 5		SAE Gr. 8	
	lbf·ft	N·m	lbf·ft	N·m	lbf·ft	N·m
1/4"	6	8	9	12	12	17
5/16"	10	13	19	25	27	36
3/8"	20	27	33	45	45	63
7/16"	30	41	53	72	75	100
1/2"	45	61	80	110	115	155
9/16"	60	95	115	155	165	220
5/8"	95	128	160	215	220	305
3/4"	165	225	290	390	400	540
7/8"	170	230	420	570	650	880
1"	225	345	630	850	970	1320



Metric Bolt Torque Specifications				
Bolt Diameter	Torque Value			
	Gr. 8.8		Gr. 10.9	
	lbf·ft	N·m	lbf·ft	N·m
M3	0.4	0.5	1.3	1.8
M4	2.2	3	3.3	4.5
M6	7	10	11	15
M8	18	25	26	35
M10	37	50	52	70
M12	66	90	92	125
M14	83	112	116	158
M16	166	225	229	310
M20	321	435	450	610
M30	1,103	1 495	1,550	2 100



Hydraulic Fitting Torque Values

Tightening Flare Type Tube Fittings

1. Check flare and flare seat for defects that might cause leakage.
2. Align tube with fitting before tightening.
3. Hand-tighten swivel nut until snug.
4. To prevent twisting the tube, use two wrenches. Place one wrench on the connector body and tighten the swivel nut with the second. Torque to values shown.

If a torque wrench is not available, use the FFFT (Flats From Finger Tight) method.

Hydraulic Fitting Torque					
Tube Size OD	Hex Size Across Flats	Torque value		Flats From Finger Tight	
		lbf•ft	N•m	Flats	Turns
3/16	7/16	6	8	2	1/6
1/4	9/16	11–12	15–17	2	1/6
5/16	5/8	14–16	19–22	2	1/6
3/8	11/16	20–22	27–30	1-1/4	1/6
1/2	7/8	44–48	59–65	1	1/6
5/8	1	50–58	68–79	1	1/6
3/4	1-1/4	79–88	107–119	1	1/8
1	1-5/8	117–125	158–170	1	1/8

Values shown are for non-lubricated connections.

Wheel Lug Torque Values

It is extremely important safety procedure to apply and maintain proper wheel mounting torque on your trailer axle. Torque wrenches are the best method to assure the proper amount of torque is being applied to a fastener.

Wheel lugs should be torqued before first road use and after each wheel removal. Check and re torque after the first 10 miles (16 km), 25 miles (40 km), and again at 50 miles (80 km). Check periodically thereafter.

NOTE: *Wheel lugs must be applied and maintained at the proper torque levels to prevent loose wheels, broken studs, and possible dangerous separation of wheels from your axle.*

- Start all lugs by hand to prevent cross threading.
- Tighten lugs in sequence, per wheel lug torque sequence chart.
- The tightening of the fasteners should be done in stages. Following the recommended sequence, tighten fasteners per wheel torque requirements chart.

Wheel Lug Nut Torque				
Wheel Size	Units	1st Stage	2nd Stage	3rd Stage
8"	lbf•ft N•m	12–20 16–26	30–35 39–45.5	45–55 58.5–71.5
12"	lbf•ft N•m	20–25 26–32.5	35–40 45.5–52	50–60 65–78
13"	lbf•ft N•m	20–25 26–32.5	35–40 45.5–52	50–60 65–78
14"	lbf•ft N•m	20–25 26–32.5	50–60 65–78	90–120 117–156
15"	lbf•ft N•m	20–25 26–32.5	50–60 65–78	90–120 117–156
16"	lbf•ft N•m	20–25 26–32.5	50–60 65–78	90–120 117–156

Wheel Lug Torque Pattern

