

PARTS MANUAL

Serial Number 1100234 and up

WXR720/L Trailer Wood Splitter

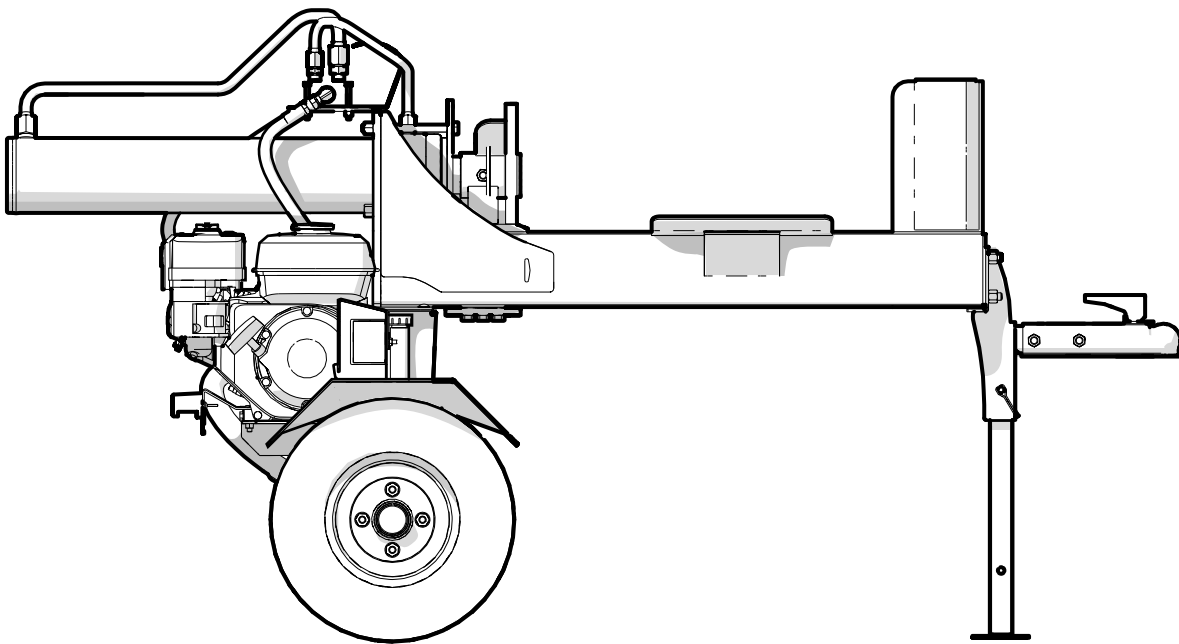

Foreword

This Wallenstein parts manual is prepared to assist customers in ordering quality OEM replacement parts.

Regular maintenance combined with replacing old, worn or broken parts with the correct OEM parts is essential in prolonging the life of your Wallenstein product. Refer to this manual to identify replacement parts.

To order parts, contact your Wallenstein dealer or distributor. Have the product model and serial number handy.

If your dealer is no longer available, please go to WallensteinEquipment.com. At the bottom of the page, select Dealer Locator.

All information contained in this parts manual is current as per the revision date at the bottom of the page. Wallenstein reserves the right to change product specifications at any time without notice.

If your product specifications differ from those contained in this manual, contact Wallenstein for current information.

Reproduction of information in this parts manual is prohibited without prior written permission from Wallenstein Equipment Inc.

Wallenstein Equipment Inc. • © 2023

WARNING!

For safety, operation, and maintenance information, see the Operator's Manual.

Maintenance should be performed by trained personnel only.

Serial Number Location

Always provide the model and serial number of your Wallenstein product when ordering parts or requesting service or other information. The serial number is on the product information plate as shown below.

Record your product information here for future reference.

Model _____

Serial Number _____

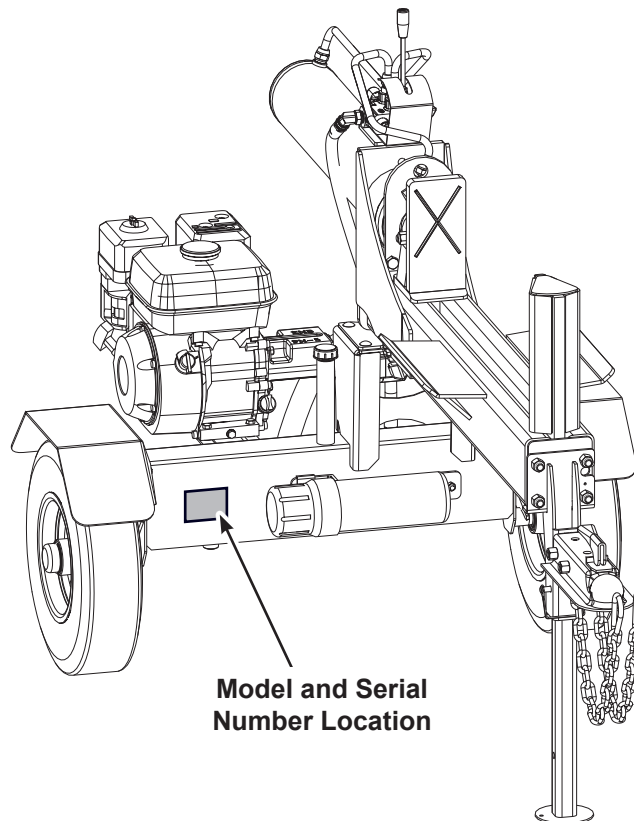

www.wallensteinequipment.com

Contents

Main Frame Assembly	4
Splitter Bed Assembly	5
Main Base Assembly	6
Hitch Assembly	7
Hub Assembly	8
Hydraulic Cylinder	8
Engine / Pump Assembly	9
Hydraulic Circuit	10
Hydraulic Valve	11
Wiring Harness – WXR720L	12
Decal Layout.....	13
Accessories	14
Common Bolt Torque Values	15
Hydraulic Fitting Torque Values	16
Wheel Lug Torque Values.....	16

Main Frame Assembly

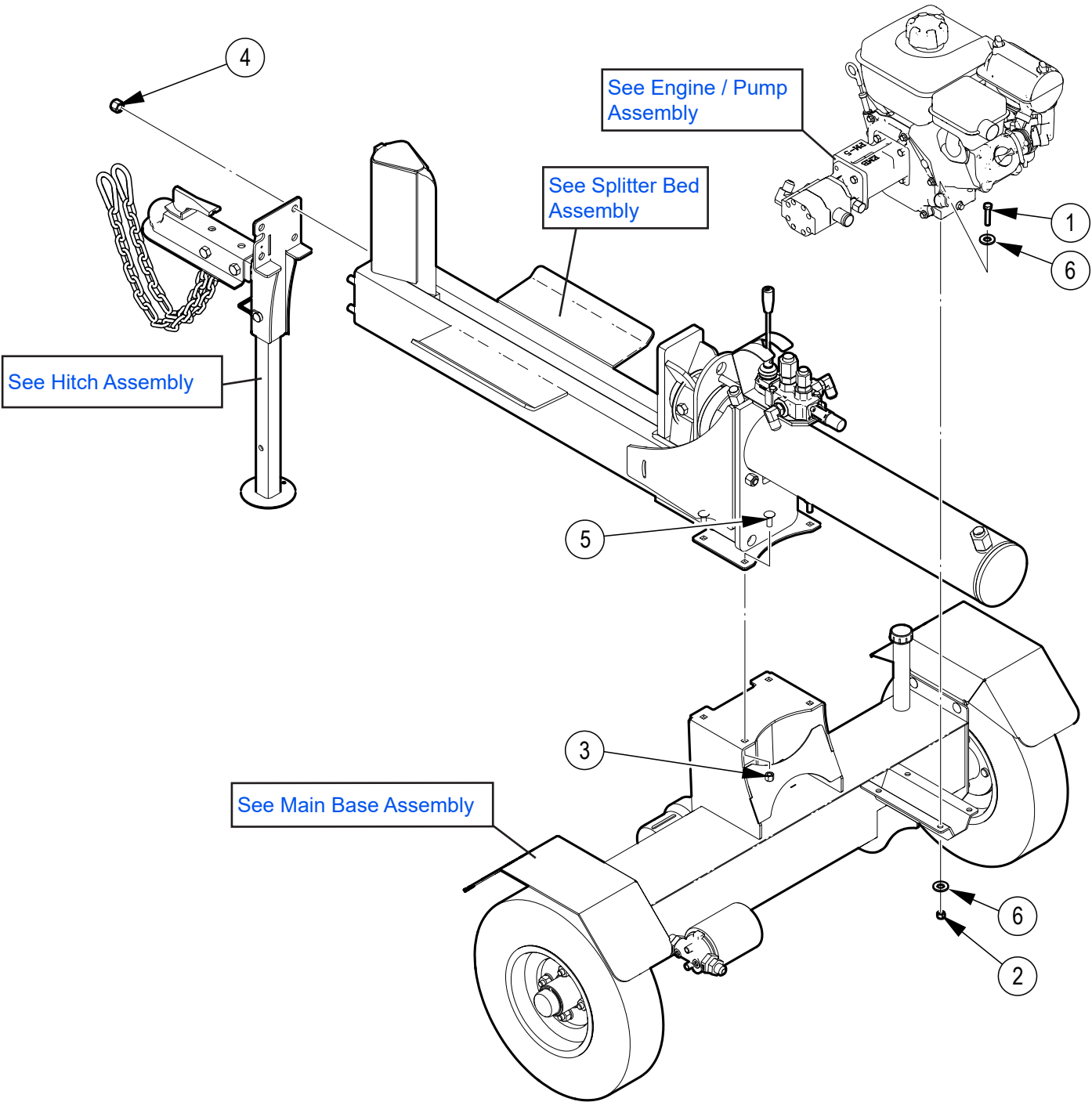

Item	Part No.	Description	Qty
1	Z71217	Hex Bolt, 5/16NC x 1-3/4"	4
2	Z72221	Hex Lock Nut, 5/16NC	4
3	Z72231	Hex Lock Nut, 3/8NC	4
4	Z72251	Hex Lock Nut, 1/2NC	4
5	Z76231	Carriage Bolt, 3/8NC x 1"	4
6	Z73122G8	SAE Washer, 5/16" Grade 8	8

Splitter Bed Assembly

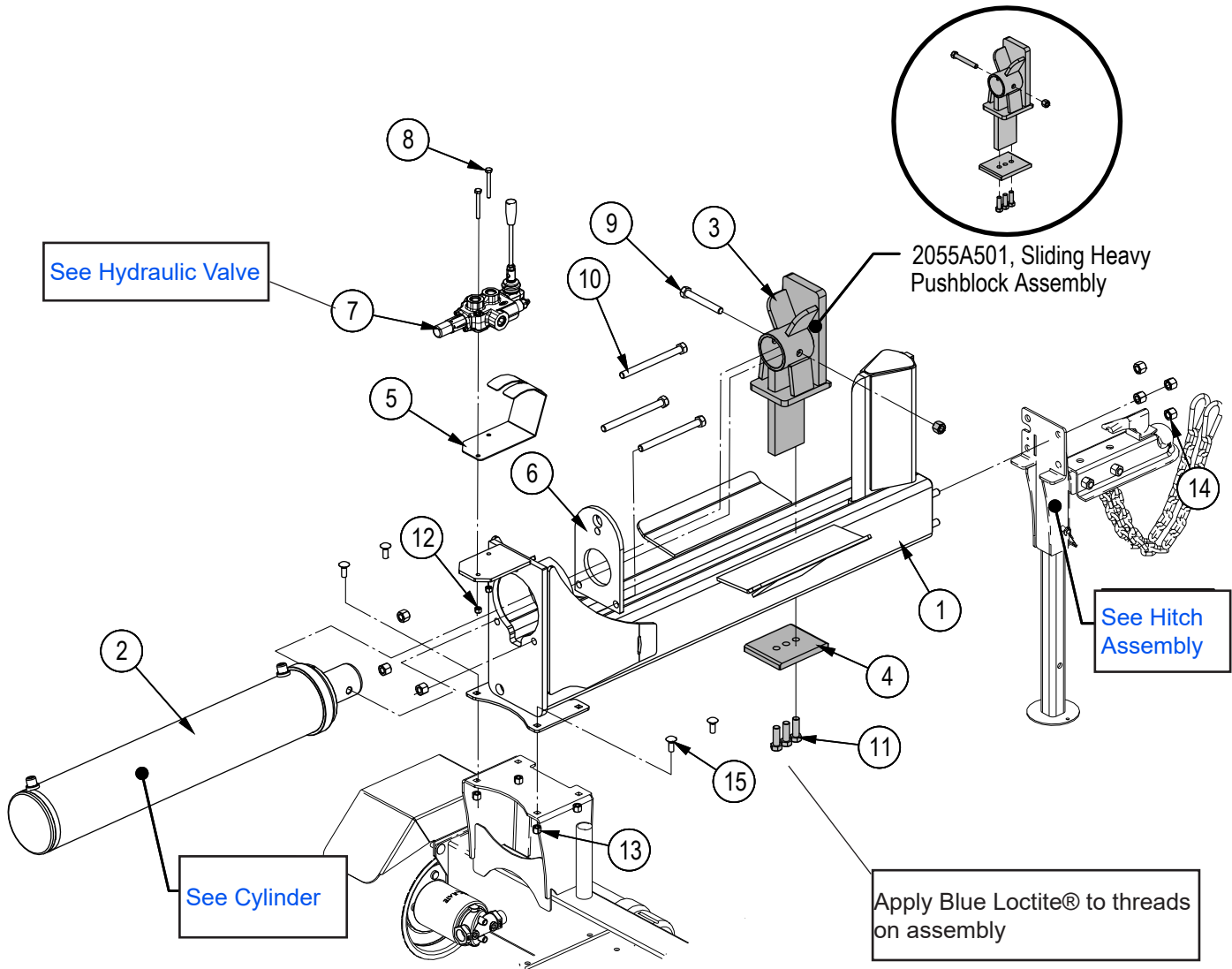

Item No.	Part No.	Description	Qty
1	2073W001	Cylinder Base, WX720	1
2	2073C020	Cylinder, 4-1/2 x 24 x 2-1/2 x JIC	1
3	2055W509	Hvy Push Block	1
4	2055S517	Cap, Push Block	1
5	2073L007	Control Plate, Regen Valve	1
6	2032S213	Cylinder Retaining Plate	1
7	Z56223	Single Spool Valve, OC Regen SCDK x 12GPM	1
8	Z71122	Hex Bolt, 1/4NC x 2-1/4"	2
9	Z71537	Hex Bolt, 1/2NC x 3-3/4"	1
10	Z71560	Hex Bolt, 1/2NC x 6"	3
11	Z71576G8	Hex Bolt, 1/2NF x 1-1/2" G8	3
12	Z72211	Hex Lock Nut, 1/4NC	2
13	Z72231	Hex Lock Nut, 3/8NC	4
14	Z72251	Hex Lock Nut, 1/2NC	8
15	Z76231	Carriage Bolt, 3/8NC x 1"	4

Main Base Assembly

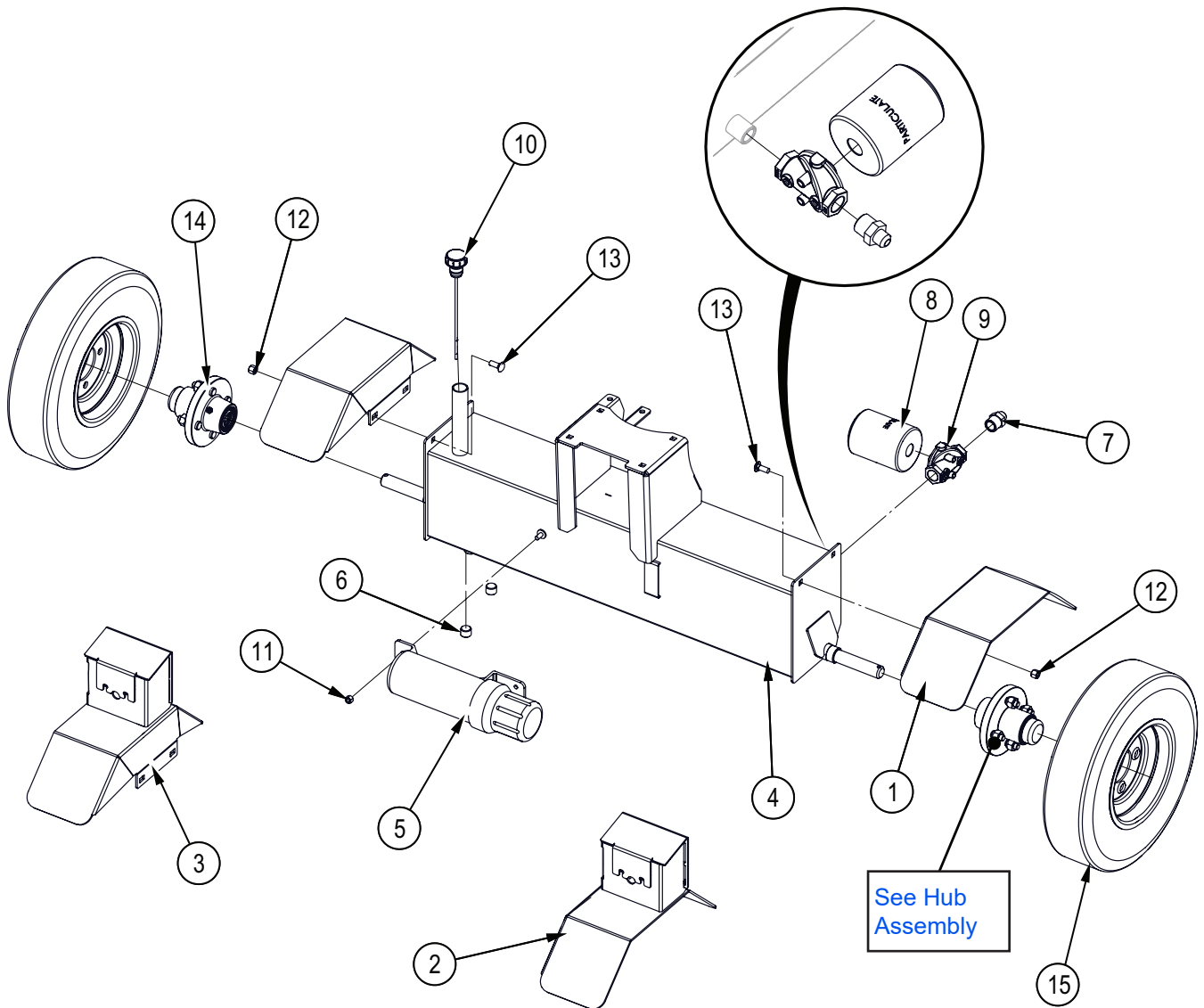

Item No.	Part No.	Description	Qty
1	2054W408	Fender - WX520 & WX520T	2
2	2054W408-LLH	LH Fender for Light Kit - WX520L	1
3	2054W408-LRH	RH Fender for Light Kit - WX520L	1
4	2073W004	WX720 Tank Axle	1
5	Z96503	Manual Tube, 3-1/2" Short	1
6	Z51192	Socket Plug, MP 08	2
7	Z51447	Straight, MJIC x MP 0812	1
8	Z55301	Particulate Filter, FP12	1
9	Z55302	Filter Cap, MP12 x FP12	1
10	Z55404	Vented Plug Dipstick x 9"	1
11	Z72221	Hex Lock Nut, 5/16NC	1
12	Z72231	Hex Lock Nut, 3/8NC	4
13	Z76231	Carriage Bolt, 3/8NC x 1"	4
14	Z91202	Idler Hub Assy, 1000lbs x 4on4" x 1"	2
15	Z91301	4.80-8 LRB SportTrail 4on4"	2

Note:
 WX720L has 2054W408-LLH and
 2054W408-LRH Fenders for Light Kit

Hitch Assembly

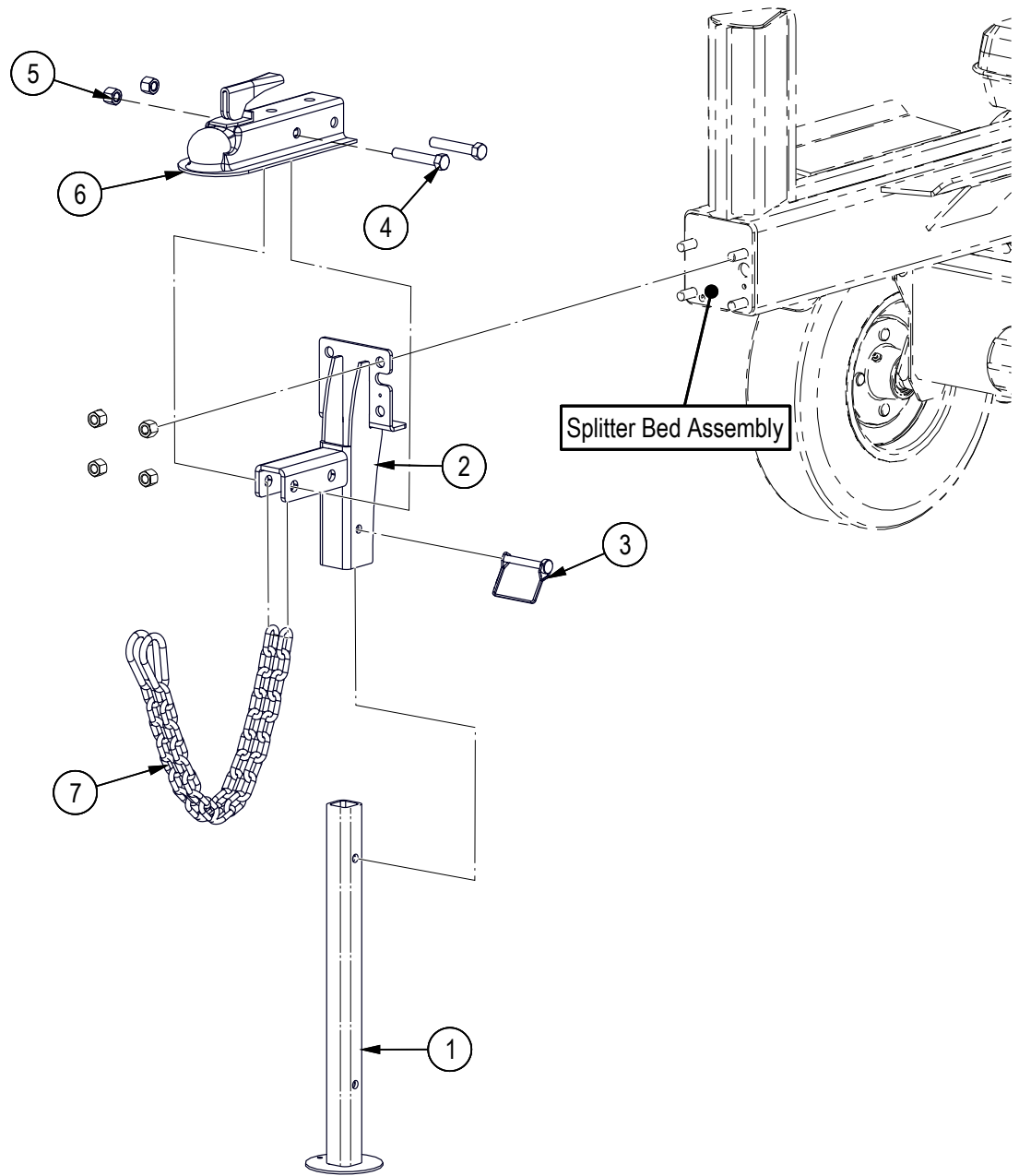

Item No.	Part No.	Description	Qty
1	2052W206	Jack Stand, Front	1
2	2073W002	Hitch Mount, WX720	1
3	Z12432	Snap Lock Pin, 3/8" x 2-1/2"	1
4	Z71530	Hex Bolt, 1/2NC x 3"	2
5	Z72251	Hex Lock Nut, 1/2NC	2
6	Z91614	Hitch Coupler, 2" Ball x 2" x 3500lbs	1
7	Z92303	Safety Chain, 1/4" x 2ft with Snap	2

Hub Assembly

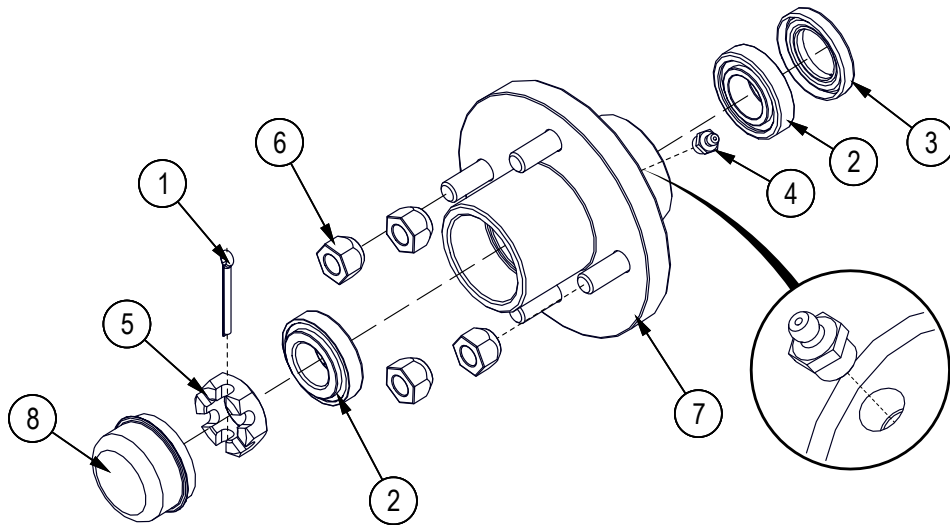

Item No.	Part No.	Description	Qty
1	Z12321	Cotter Pin, 3/16" x 1-3/4"	1
2	Z23201	Roller Bearing, L44643 L44610	2
3	Z28301	Double Lip Seal, 1-1/4"	1
4	Z29201	Grease Fitting, MP02	1
5	Z72691	Castle Nut, 1NF x 9/16" Thick	1
6	Z72931	Lug Nut, 1/2NF	4
7	Z91201	Hub, 1000lbs x 4on4	1
8	Z91801	Dust Cap, 1.98 Bore	1

Hydraulic Cylinder

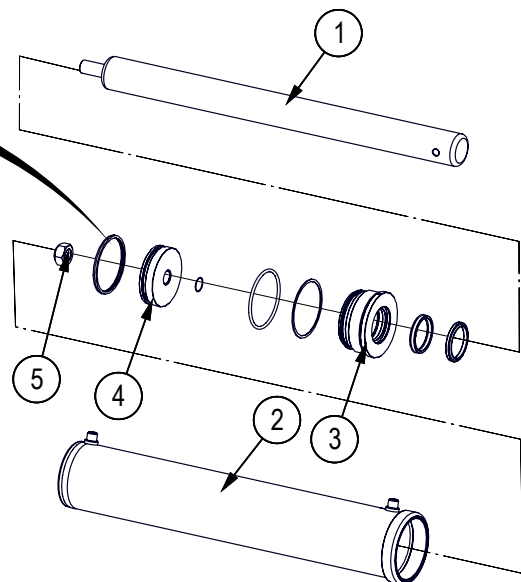

Item No.	Part No.	Description	Qty
1	2073C0202	Rod, 2-1/2 x 1	1
2	2073C0204	Barrel, 4-1/2" x JIC	1
3	G450-250S	Gland, 4-1/2" x 2-1/2"	1
4	P100-450SP	Piston, 4-1/2" Bore	1
5	Z722909	Hex Top-lock Nut, 1-14NF	1

Engine / Pump Assembly

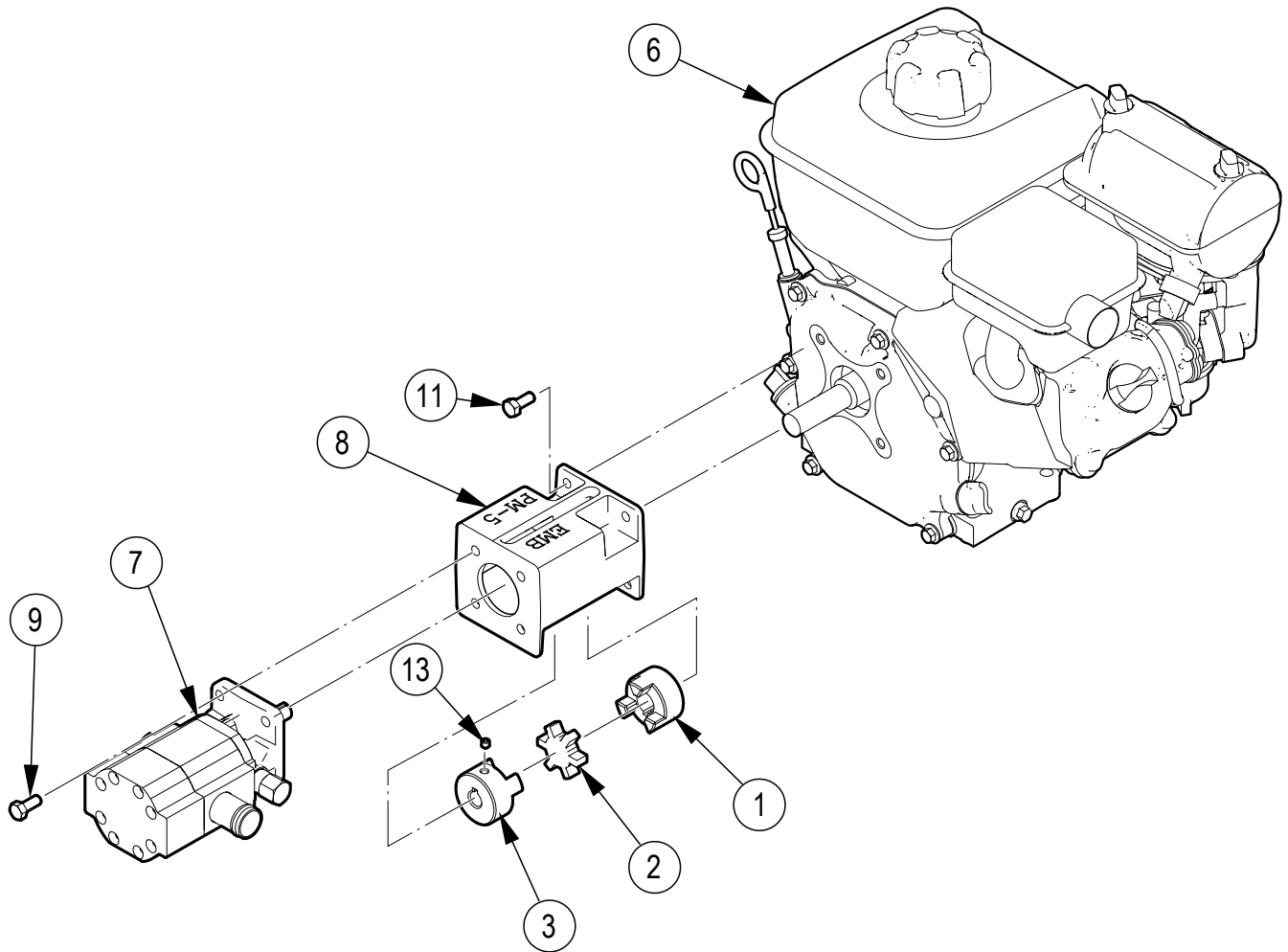

Item	Part No.	Description	Qty
1	Z46406	Shaft Coupler, L075 x 3/4"	1
2	Z46408	Spider, L075	1
3	Z46410	Shaft Coupling, L075 x 1/2"	1
6	Z47752	Vanguard 6.5 hp (203cc)	1
7	Z53204	Two-Stage Pump, 11GPM	1
8	Z53801	Pump Mount, PM-5	1
9	Z71207	Hex Bolt, 5/16NC x 3/4"	4
11	Z71273	Hex Bolt, 5/16NF x 3/4"	4
13	Z74111	Set Screw, 1/4NC x 1/4"	2

Hydraulic Circuit

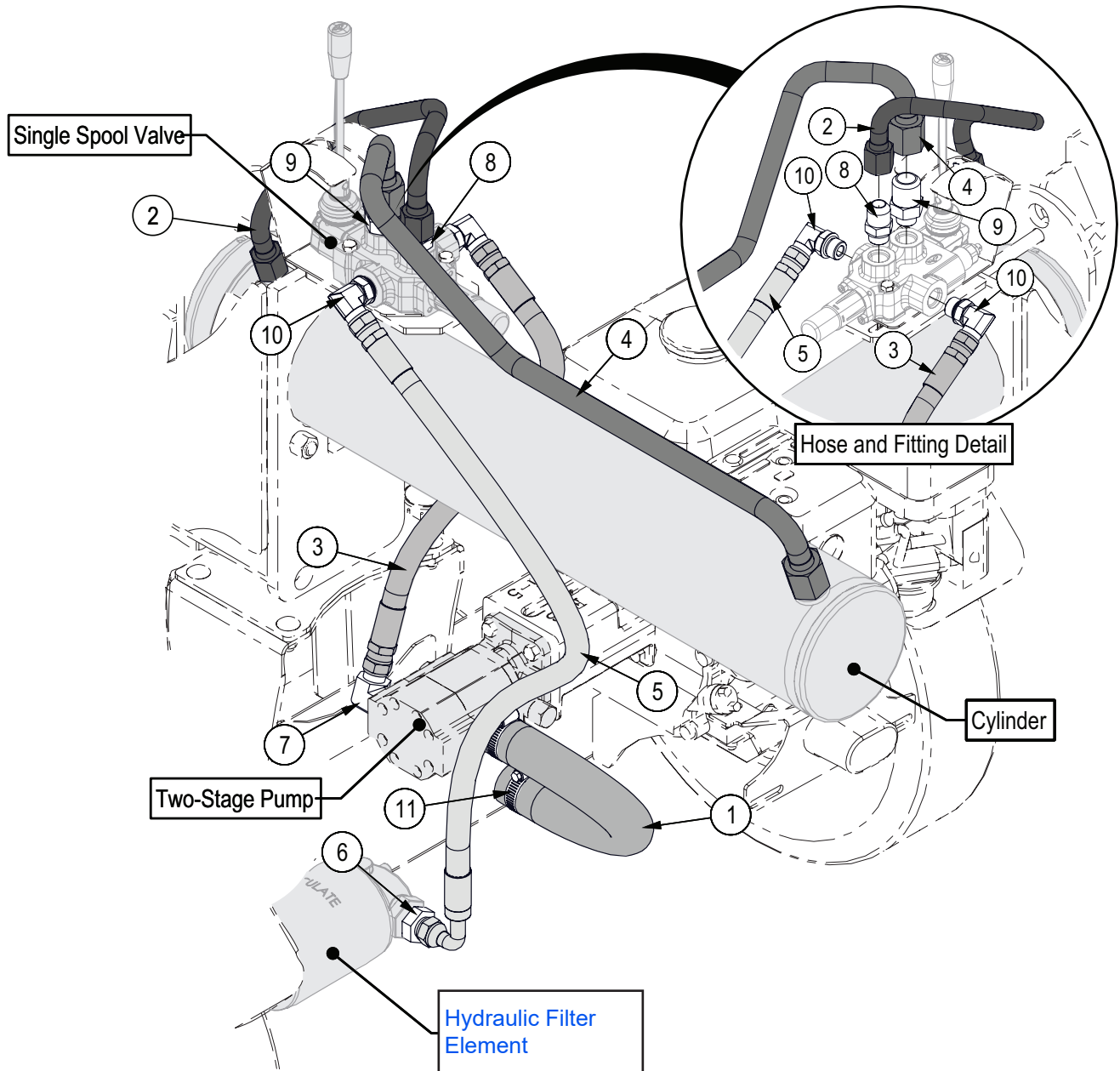

ECN0431

Item No.	Part No.	Description	Qty
1	2073F006	Suction Hose, 1" x 32"	1
2	2073F002	1/2" Tube, FJIC08 x FJIC08 x 16-7/8"	1
3	2073F003	1/2" Hose, FJIC08 x FJIC08 x 19"	1
4	2073F004	3/4" Tube, FJICX10 x FJICX12 x 28-3/16"	1
5	2073F005	1/2" Hose, FJIC08 x 90FJIC08 x 32"	1
6	Z51447	Straight, MJIC x MP 0812	1
7	Z51451	Elbow 90, MJIC x MP 0808	1
8	Z516410	Straight, MJIC x MORB 1008	1
9	Z516411	Straight, MJIC x MORB 1208	1
10	Z51653	Elbow 90, MJIC x MORB 0808	2
11	Z79401	Hose Clamp, SAE #16 (1-1/2")	2

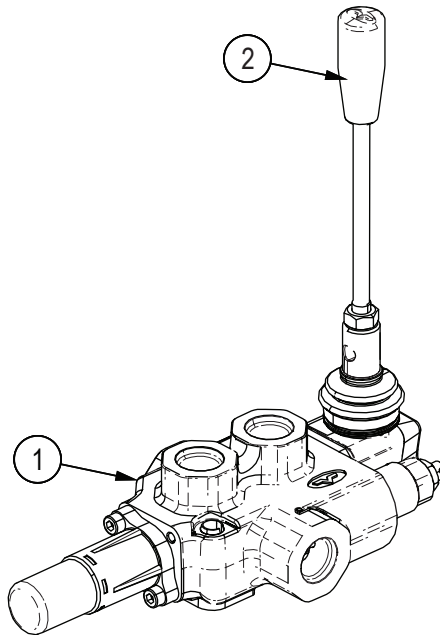
Hydraulic Valve

Z56223 Hydraulic Control Valve

Item No.	Part No.	Description
1	119484	Seal Kit
2	AL01/M8X150	Handle Kit

Wiring Harness – WXR720L

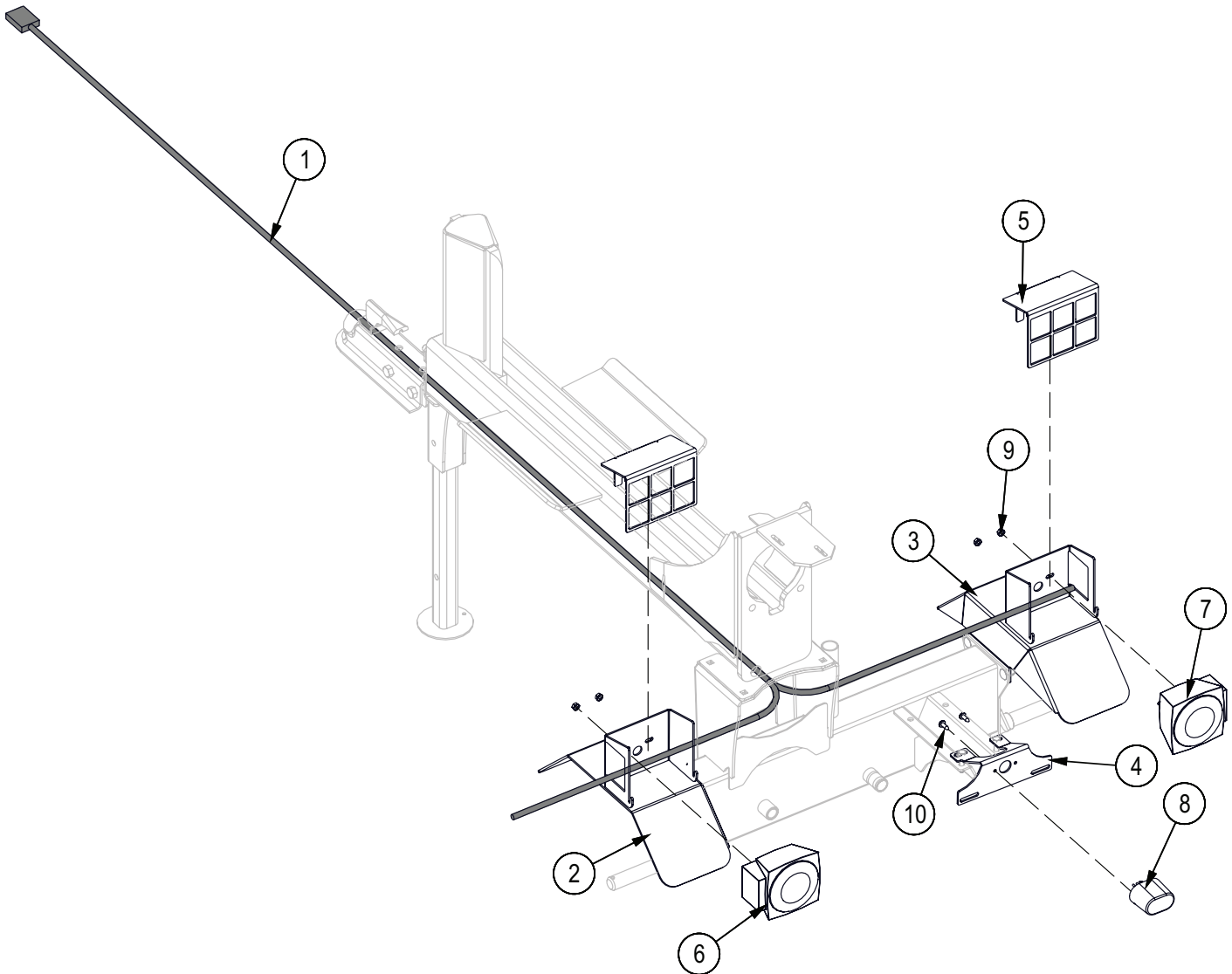

Item No.	Part No.	Description	Qty
1	Z62105	Harness, 110" Lights	1
2	2054W408-LLH	LH Fender for Light Kit	1
3	2054W408-LRH	RH Fender for Light Kit	1
4	2052L210	License Bracket	1
5	2089L351	Light Guard	2
6	Z61106	STTL Lamp, Square LH	1
7	Z61107	STT Lamp, Square RH	1
8	Z61301	License Lamp, White	1
9	Z72941	Serrated Washer Nut, 1/4NC	4
10	Z76721	Self-tapping Screw, 1/4" x 3/4"	2

IMPORTANT! When assembling or replacing wire harnesses, apply a thin coating of silicone dielectric grease to the harness connectors.

Clean off any corrosion or loose particles, then apply a small amount to the surfaces of the connectors where they meet. The grease helps to stop any possibility of future corrosion.

Reassemble the connection. Wipe off any grease that squeezes out.

Decal Layout

IMPORTANT! If parts are replaced that have safety signs on them, new signs must be applied. Safety signs must always be replaced if they become damaged, are removed, or become illegible.

WXR720 shown. Decal placement identical on WXR720L.

Safety signs are included in the product decal kit available from your authorized dealer. Decals are not available separately.

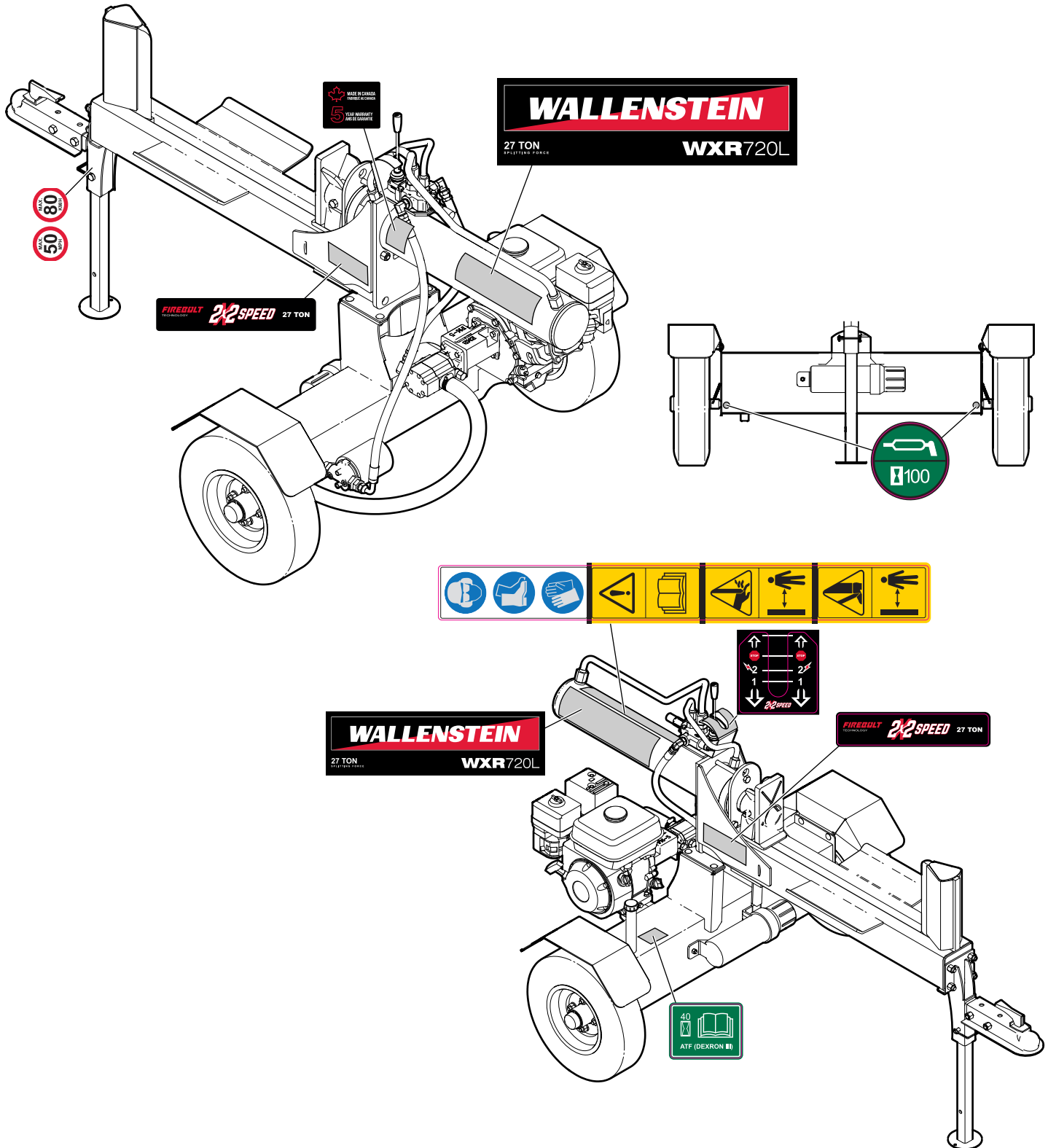

Accessories

Call your dealer for pricing and availability

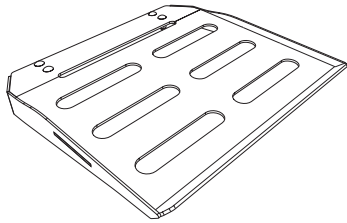

Clamp-on Shelf Extension – P/N W4211

Fits all WXR splitter models.

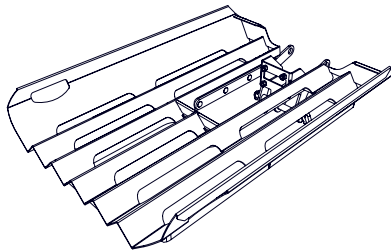

Folding Splitter Shelf – P/N W4212

Fits all WXR splitter models.

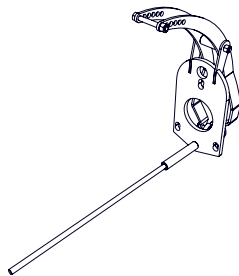

Splitter Stroke Limiter – P/N W4213

Manually set return stroke.

Common Bolt Torque Values

Checking Bolt Torque

The tables shown give correct torque values for various bolts and capscrews. Tighten all bolts to the torque values specified in the table, unless indicated otherwise. Check tightness of bolts periodically.

IMPORTANT! If replacing hardware, use fasteners of the same grade.

IMPORTANT! Torque figures indicated in the table are for non-greased or non-oiled threads. Do not grease or oil threads unless indicated otherwise. When using a thread locker, increase torque values by 5%.

 **NOTE:** Bolt grades are identified by their head markings.

Imperial Bolt Torque Specifications

Bolt Diameter	Torque Value					
	SAE Gr. 2		SAE Gr. 5		SAE Gr. 8	
	lbf•ft	N•m	lbf•ft	N•m	lbf•ft	N•m
1/4"	6	8	9	12	12	17
5/16"	10	13	19	25	27	36
3/8"	20	27	33	45	45	63
7/16"	30	41	53	72	75	100
1/2"	45	61	80	110	115	155
9/16"	60	95	115	155	165	220
5/8"	95	128	160	215	220	305
3/4"	165	225	290	390	400	540
7/8"	170	230	420	570	650	880
1"	225	345	630	850	970	1320



SAE Gr. 2



SAE Gr. 5



SAE Gr. 8

Metric Bolt Torque Specifications

Bolt Diameter	Torque Value			
	Gr. 8.8		Gr. 10.9	
	lbf•ft	N•m	lbf•ft	N•m
M3	0.4	0.5	1.3	1.8
M4	2.2	3	3.3	4.5
M6	7	10	11	15
M8	18	25	26	35
M10	37	50	52	70
M12	66	90	92	125
M14	83	112	116	158
M16	166	225	229	310
M20	321	435	450	610
M30	1,103	1 495	1,550	2 100



8.8



10.9

Hydraulic Fitting Torque Values

Tightening Flare Type Tube Fittings

1. Check flare and flare seat for defects that might cause leakage.
2. Align tube with fitting before tightening.
3. Hand-tighten swivel nut until snug.
4. To prevent twisting the tube, use two wrenches. Place one wrench on the connector body and tighten the swivel nut with the second. Torque to values shown.

If a torque wrench is not available, use the FFFT (Flats From Finger Tight) method.

Hydraulic Fitting Torque					
Tube Size OD	Hex Size Across Flats	Torque value		Flats From Finger Tight	
		lbf•ft	N•m	Flats	Turns
3/16	7/16	6	8	2	1/6
1/4	9/16	11–12	15–17	2	1/6
5/16	5/8	14–16	19–22	2	1/6
3/8	11/16	20–22	27–30	1-1/4	1/6
1/2	7/8	44–48	59–65	1	1/6
5/8	1	50–58	68–79	1	1/6
3/4	1-1/4	79–88	107–119	1	1/8
1	1-5/8	117–125	158–170	1	1/8

Values shown are for non-lubricated connections.

Wheel Lug Torque Values

It is extremely important safety procedure to apply and maintain proper wheel mounting torque on your trailer axle. Torque wrenches are the best method to assure the proper amount of torque is being applied to a fastener.

Wheel lugs should be torqued before first road use and after each wheel removal. Check and re torque after the first 10 miles (16 km), 25 miles (40 km), and again at 50 miles (80 km). Check periodically thereafter.

NOTE: *Wheel lugs must be applied and maintained at the proper torque levels to prevent loose wheels, broken studs, and possible dangerous separation of wheels from your axle.*

- Start all lugs by hand to prevent cross threading.
- Tighten lugs in sequence, per wheel lug torque sequence chart.
- The tightening of the fasteners should be done in stages. Following the recommended sequence, tighten fasteners per wheel torque requirements chart.

Wheel Lug Nut Torque				
Wheel Size	Units	1st Stage	2nd Stage	3rd Stage
8"	lbf•ft N•m	12–20 16–26	30–35 39–45.5	45–55 58.5–71.5
12"	lbf•ft N•m	20–25 26–32.5	35–40 45.5–52	50–60 65–78
13"	lbf•ft N•m	20–25 26–32.5	35–40 45.5–52	50–60 65–78
14"	lbf•ft N•m	20–25 26–32.5	50–60 65–78	90–120 117–156
15"	lbf•ft N•m	20–25 26–32.5	50–60 65–78	90–120 117–156
16"	lbf•ft N•m	20–25 26–32.5	50–60 65–78	90–120 117–156

Wheel Lug Torque Pattern

