

PARTS MANUAL

Serial Number 330S001 & up

LXG330S 3 PH GRAPPLE

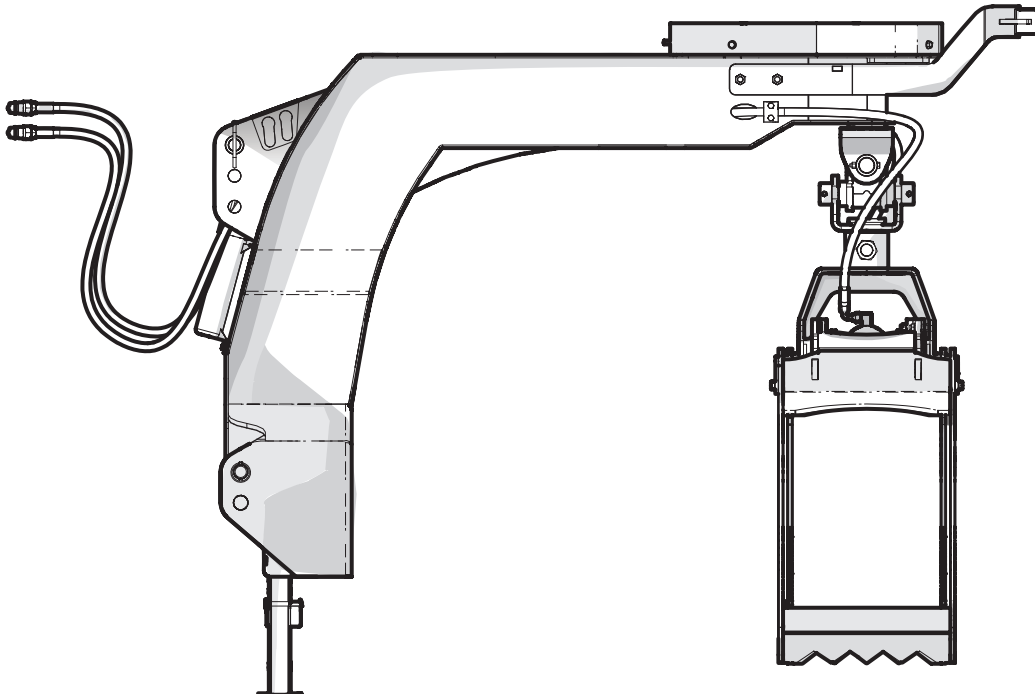

Foreword

This Wallenstein parts manual is prepared to assist customers in ordering quality OEM replacement parts.

Regular maintenance combined with replacing old, worn or broken parts with the correct OEM parts is essential in prolonging the life of your Wallenstein product. Refer to this manual to identify replacement parts.

To order parts, contact your Wallenstein dealer or distributor. Have the product model and serial number handy.

If your dealer is no longer available, please go to our website: <http://wallensteinequipment.com> and click on the [Dealer Locator](#) to find the nearest dealer.

All information contained in this parts manual is current as per the revision date at the bottom of the page. Wallenstein reserves the right to change product specifications at any time without notice.

If your product specifications differ from those contained in this manual, contact Wallenstein for current information.

Reproduction of information in this parts manual is prohibited without prior written permission from Wallenstein Equipment Inc.

Wallenstein Equipment Inc. • © 2021

WARNING!

Refer to the operators manual for safe operation and maintenance.

Maintenance should be performed by trained personnel only.

Serial Number Location

Always provide the model and serial number of your Wallenstein product when ordering parts or requesting service or other information. This information is found on the product information plate as shown below.

Record your product information here for future reference.

Model _____

Serial Number _____

**Model and Serial
Number Location**

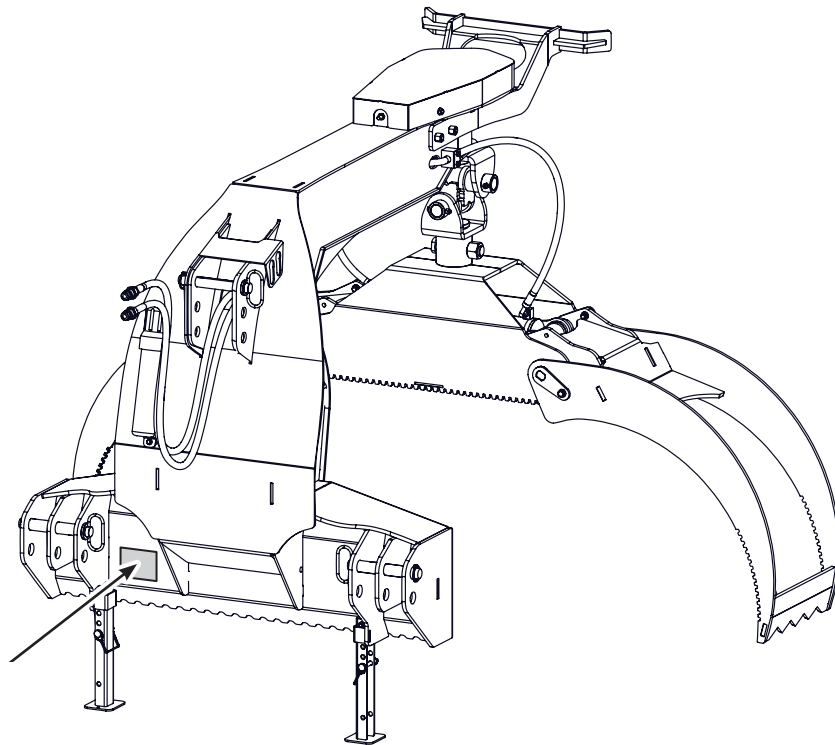

www.wallensteinequipment.com

Contents

Main Parts S/N 330S001 to 330S016.....	4A
Main Parts S/N 330S017 & Up.....	4B
Pivot Assembly Detail.....	5
Return Lock Assembly	6
Grapple Assembly S/N 330S001 to 330S016	7A
Grapple Assembly S/N 330S017 & Up.....	7B
Outer Fork Assembly S/N 330S001 to 330S016.....	8A
Outer Fork Assembly S/N 330S017 & Up.....	8B
Cylinder Detail.....	9
Hydraulic Plumbing Diagram.....	10
Decal Layout.....	11
Accessories.....	12
Common Bolt Torque Values	13
Hydraulic Fitting Torque Values	14

Main Parts S/N 330S001 to 330S016

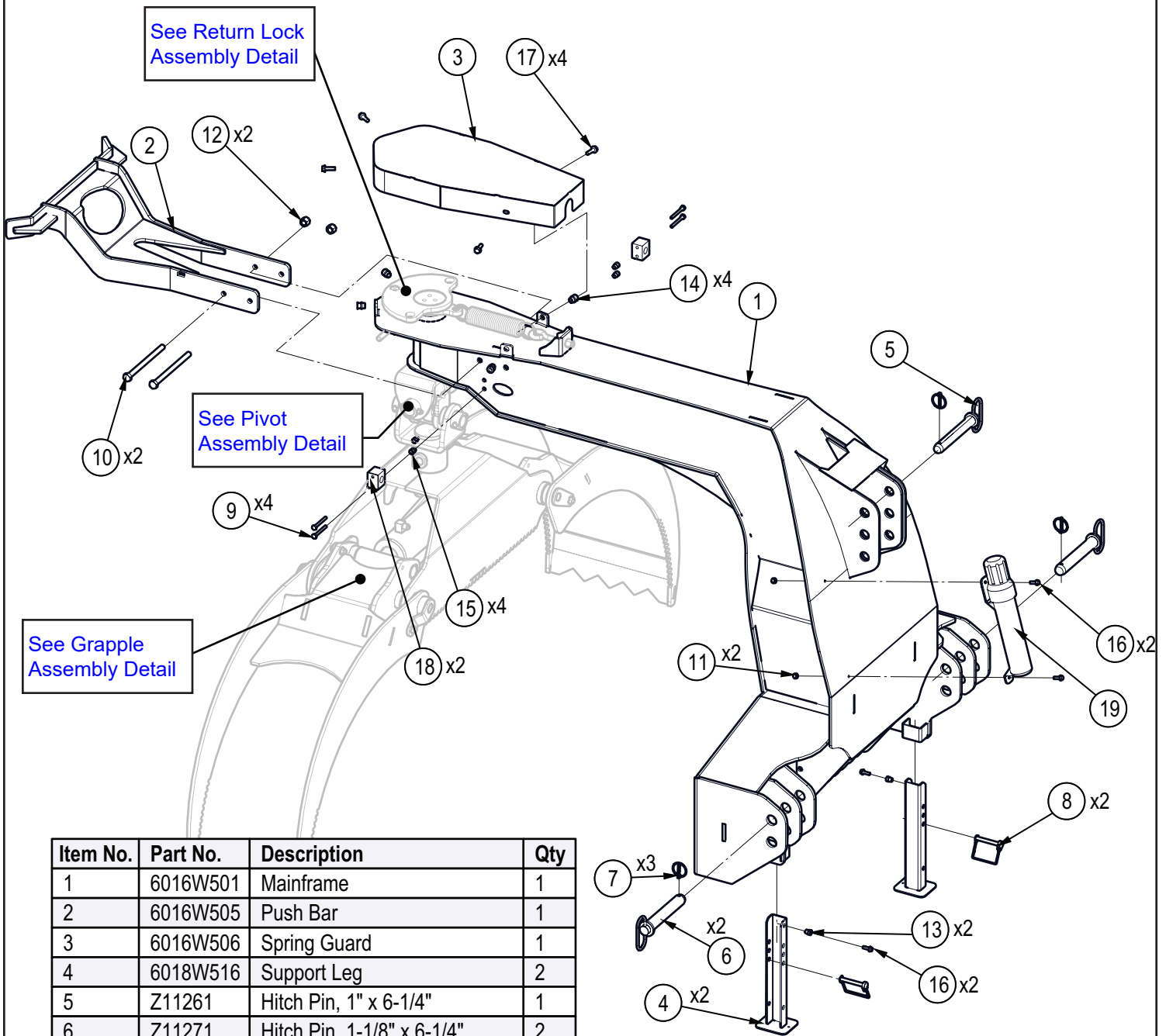

Item No.	Part No.	Description	Qty
1	6016W501	Mainframe	1
2	6016W505	Push Bar	1
3	6016W506	Spring Guard	1
4	6018W516	Support Leg	2
5	Z11261	Hitch Pin, 1" x 6-1/4"	1
6	Z11271	Hitch Pin, 1-1/8" x 6-1/4"	2
7	Z12110	Lynch Pin, 3/16"	3
8	Z12432	Snap Lock Pin, 3/8" x 2-1/2"	2
9	Z71122	Hex Bolt, 1/4NC x 2-1/4"	4
10	Z71568	Hex Bolt, 1/2NC x 7"	2
11	Z72211	Hex Lock Nut, 1/4NC	2
12	Z72251	Hex Lock Nut, 1/2NC	2
13	Z72955	Rivet Nut, 1/4NC x 165	2
14	Z72957	Rivet Nut, 5/16NC x 312	4
15	Z72962	Rivet Nut, 1/4NC x 260	4
16	Z76111	Flange Bolt, 1/4NC x 3/4"	4
17	Z76125	Flange Bolt, 5/16NC x 1"	4
18	Z79454	Single Hose Clamp, 11/16" OD	2
19	Z96505	Manual Tube, 2" Short	1

Main Parts S/N 330S017 & Up

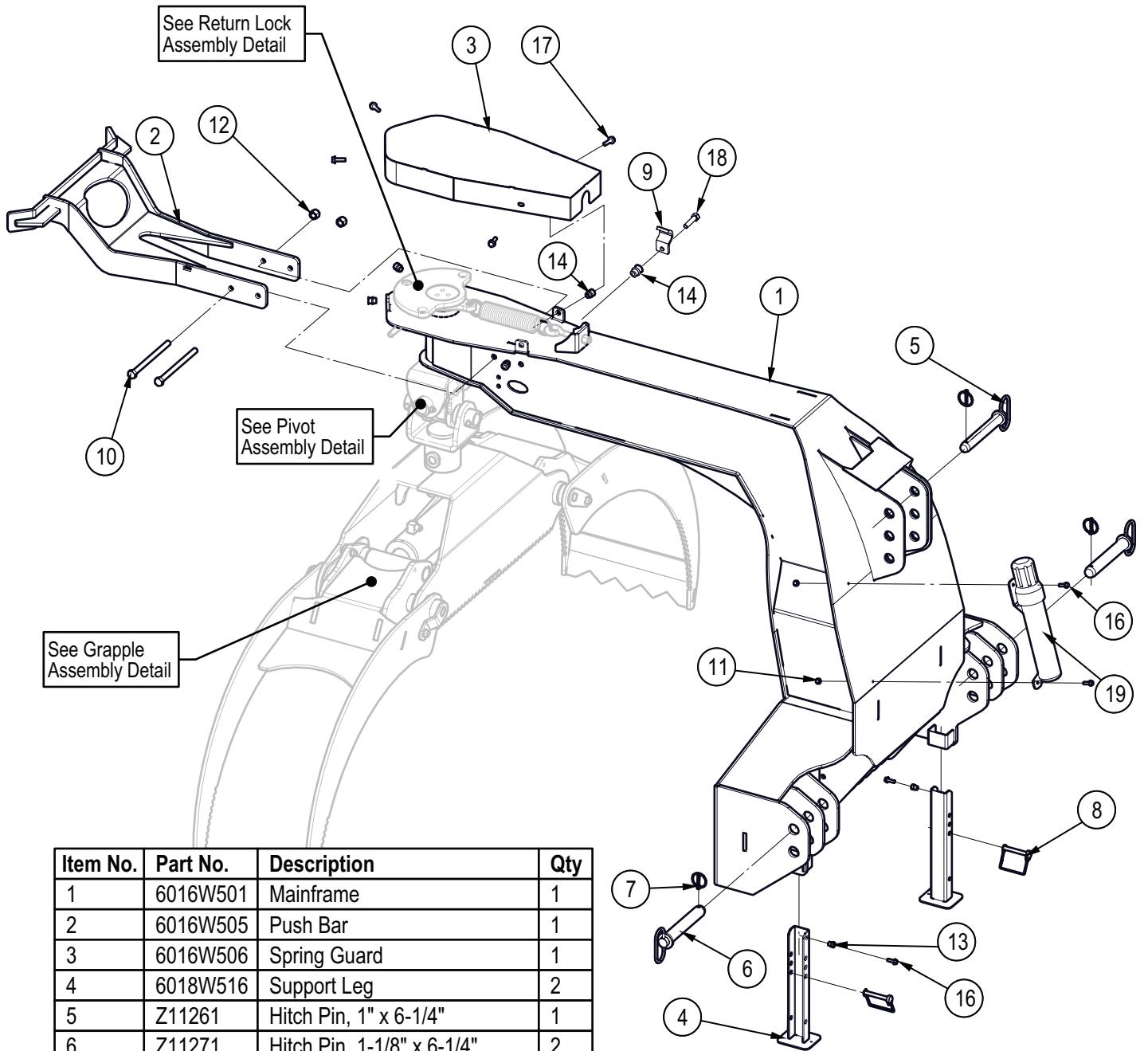

Item No.	Part No.	Description	Qty
1	6016W501	Mainframe	1
2	6016W505	Push Bar	1
3	6016W506	Spring Guard	1
4	6018W516	Support Leg	2
5	Z11261	Hitch Pin, 1" x 6-1/4"	1
6	Z11271	Hitch Pin, 1-1/8" x 6-1/4"	2
7	Z12110	Lynch Pin, 3/16"	3
8	Z12432	Snap Lock Pin, 3/8" x 2-1/2"	2
9	6011L128	Hose Clamp, 1 x 3/8"	2
10	Z71568	Hex Bolt, 1/2NC x 7"	2
11	Z72211	Hex Lock Nut, 1/4NC	2
12	Z72251	Hex Lock Nut, 1/2NC	2
13	Z72955	Rivet Nut, 1/4NC x 165	2
14	Z72957	Rivet Nut, 5/16NC x 312	6
16	Z76111	Flange Bolt, 1/4NC x 3/4"	4
17	Z76125	Flange Bolt, 5/16NC x 1"	4
18	Z71212	Hex Bolt, 5/16NC x 1-1/4"	2
19	Z96505	Manual Tube, 2" Short	1

Pivot Assembly Detail

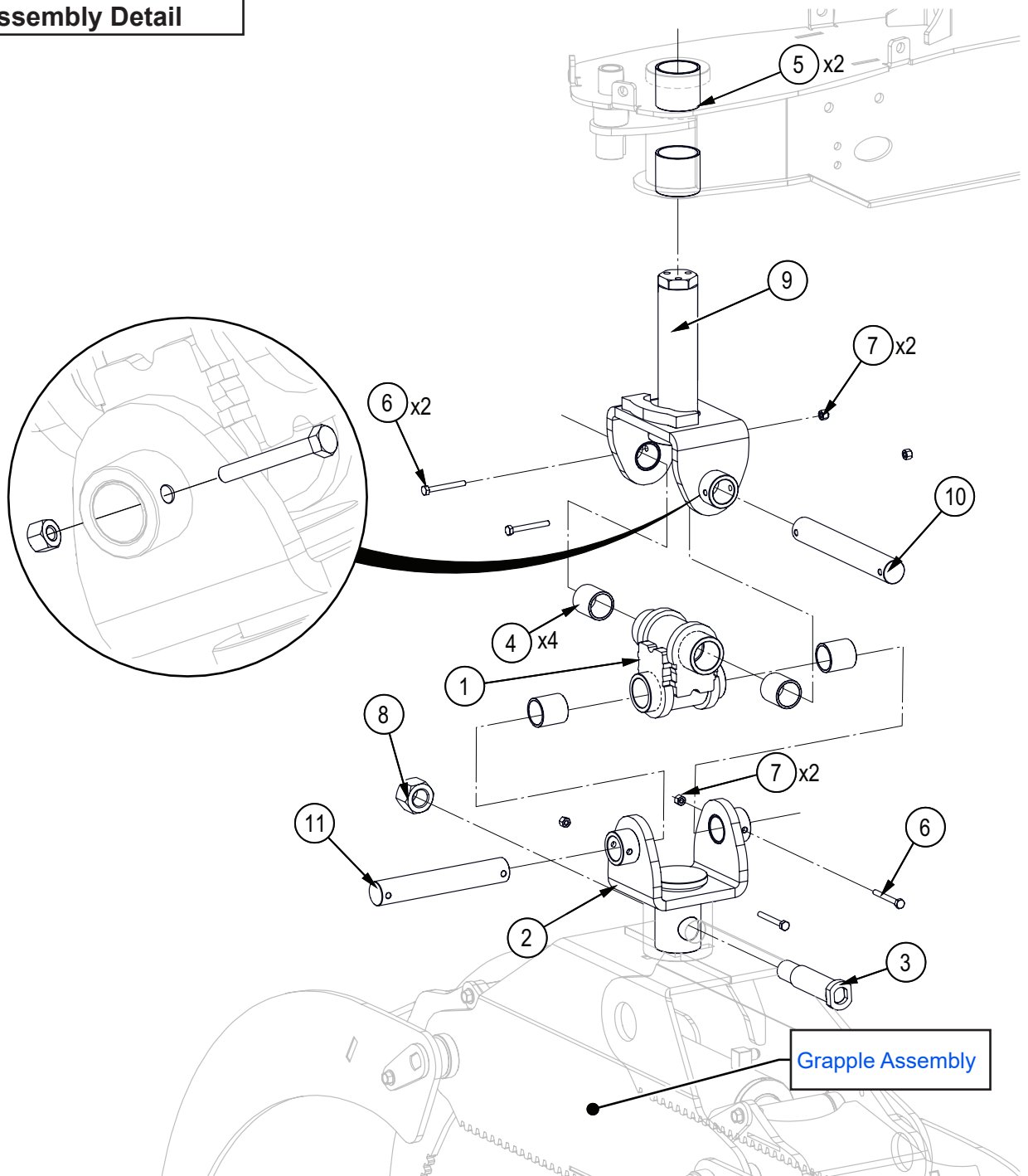

Item No.	Part No.	Description	Qty
1	6016W503	Pivot Link	1
2	6016W504	Grapple Pivot	1
3	6018W514	Clamp Mount Pin	1
4	Z27107	Composite Bearing, 1-1/4" ID x 1-1/2" long x 1/8" Wall	4
5	Z27111	Composite Bearing, 2" ID x 2" long x 1/8" Wall	2
6	Z71122	Hex Bolt, 1/4NC x 2-1/4"	4
7	Z72211	Hex Lock Nut, 1/4NC	4
8	Z72291	Hex Lock Nut, 1NC	1
9	6016W502	Main Pivot	1
10	6016M508	Pin, Top Pivot	1
11	6016M509	Pin, Bottom Pivot	1

Return Lock Assembly

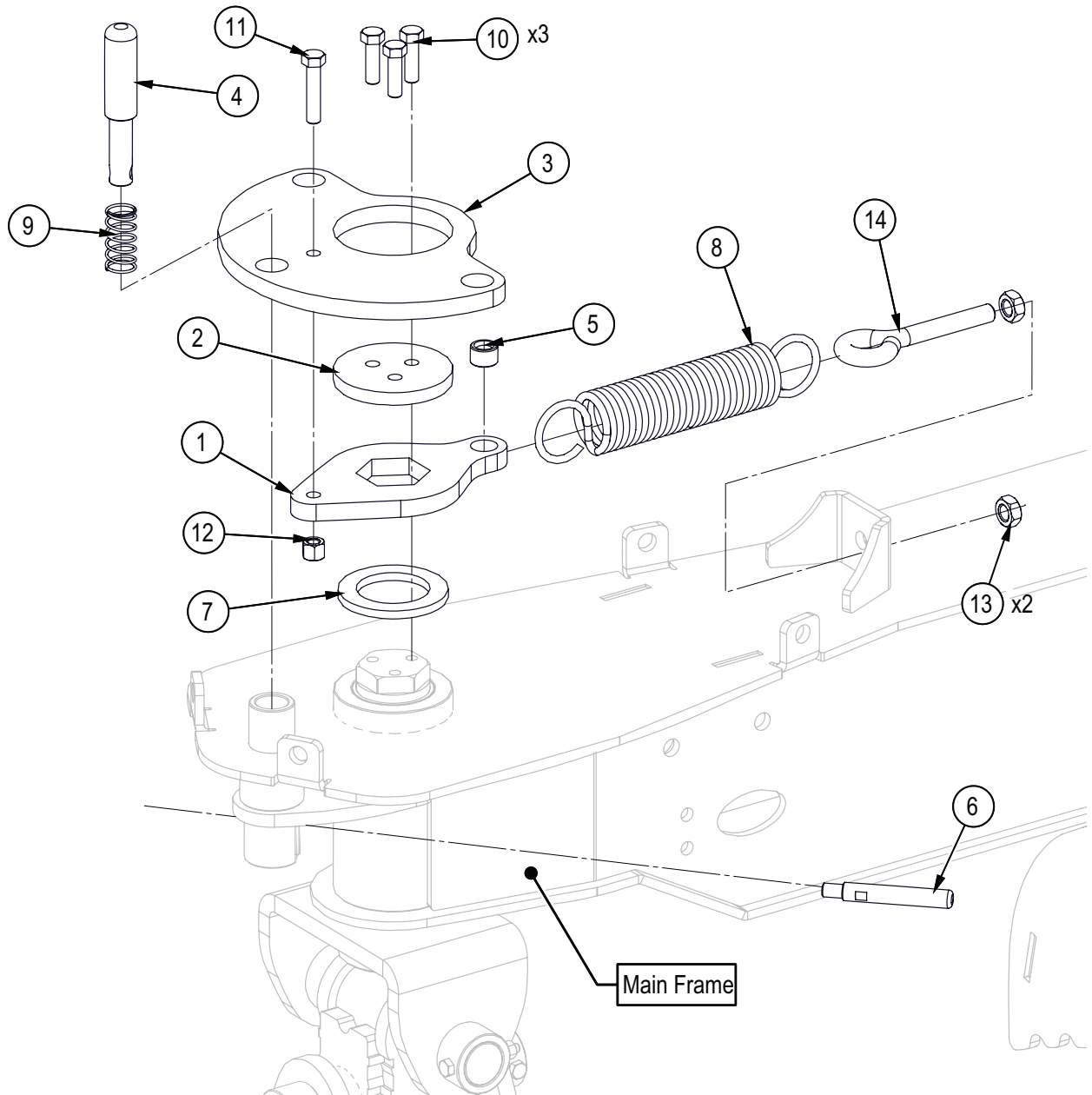

Item No.	Part No.	Description	Qty
1	6016L502	Plate, Spring Flange	1
2	6016L503	Plate, Main Pivot Keeper	1
3	6016L505	Plate, Lockout Position	1
4	6016M504	Pin, Grapple Lock	1
5	6016M505	Bushing, Spring	1
6	6016M511	Lever, Grapple Lock	1
7	Z22403	Thrust Washer, 2-1/16" ID x 0.236"	1
8	Z31502	Ext Spring, 1-3/4" OD x 9" x .207"	1
9	Z32306	Comp Spring, 0.845" OD x 1-3/4" x 0.068"	1
10	Z71312	Hex Bolt, 3/8NC x 1-1/4"	3
11	Z71317	Hex Bolt, 3/8NC x 1-3/4"	1
12	Z72231	Hex Lock Nut, 3/8NC	1
13	Z72331	Jam Nut, 3/8NC	2
14	Z76551	Eye Bolt, 1/2NC x 3"	1

Grapple Assembly S/N 330S001 to 330S016

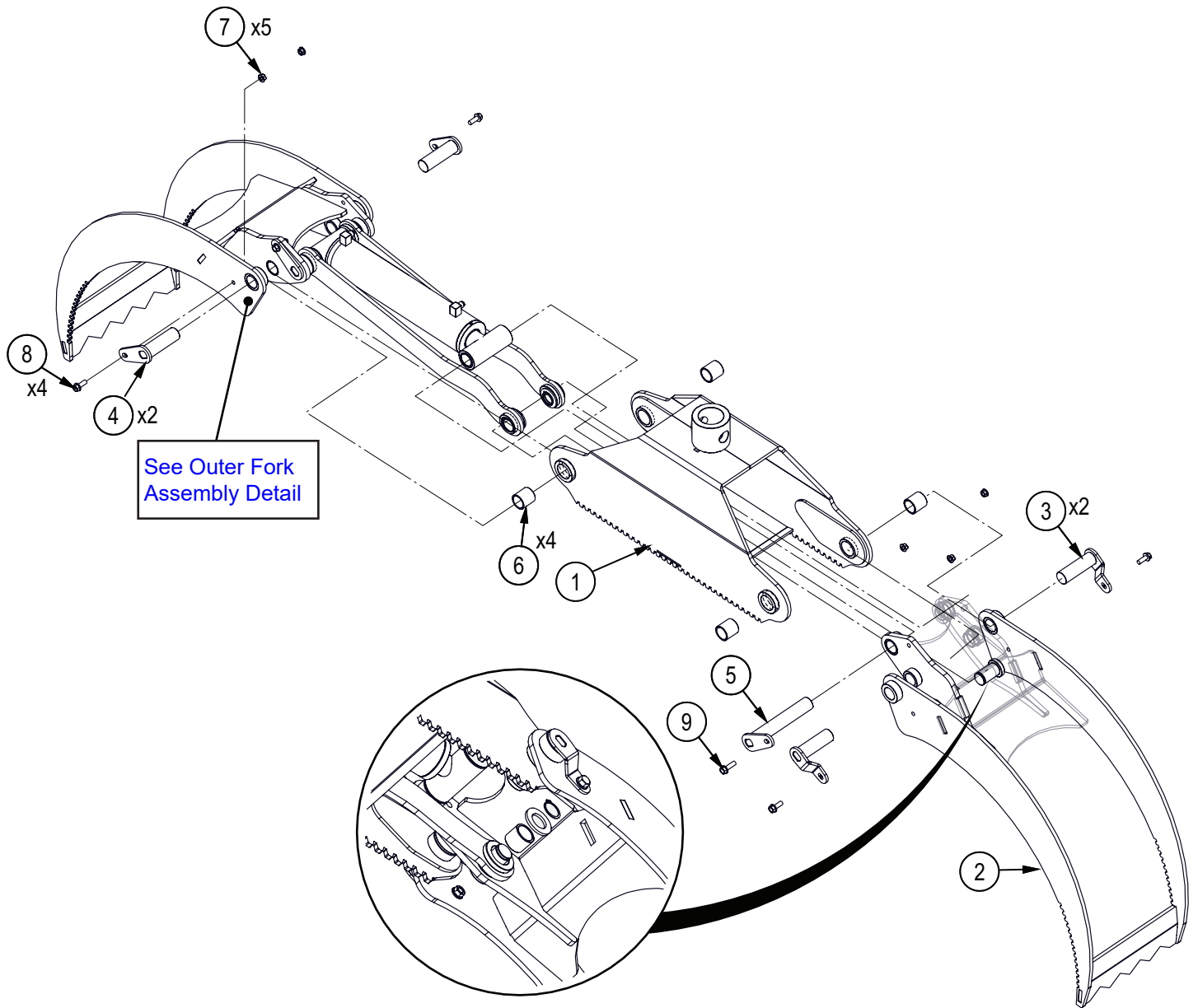

Note: See Outer Fork Assembly Detail - Items 2, 8, and 9

Item No.	Part No.	Description	Qty
1	6018W501	Grapple Housing	1
2	6018W502	Inner Fork	1
3	6018W508	Inner Fork Pin	2
4	6018W509	Outer Fork Pin	2
5	6018W510	Short Cylinder Pin	1
6	Z27107	Composite Bearing, 1-1/4" ID x 1-1/2" long x 1/8" Wall	4
7	Z72531	Serrated Flange Locknut, 3/8NC	5
8	Z76134	Flange Bolt, 3/8NC x 1"	4
9	Z76137	Flange Bolt, 3/8NC x 1-1/4"	1

Grapple Assembly S/N 330S017 & Up

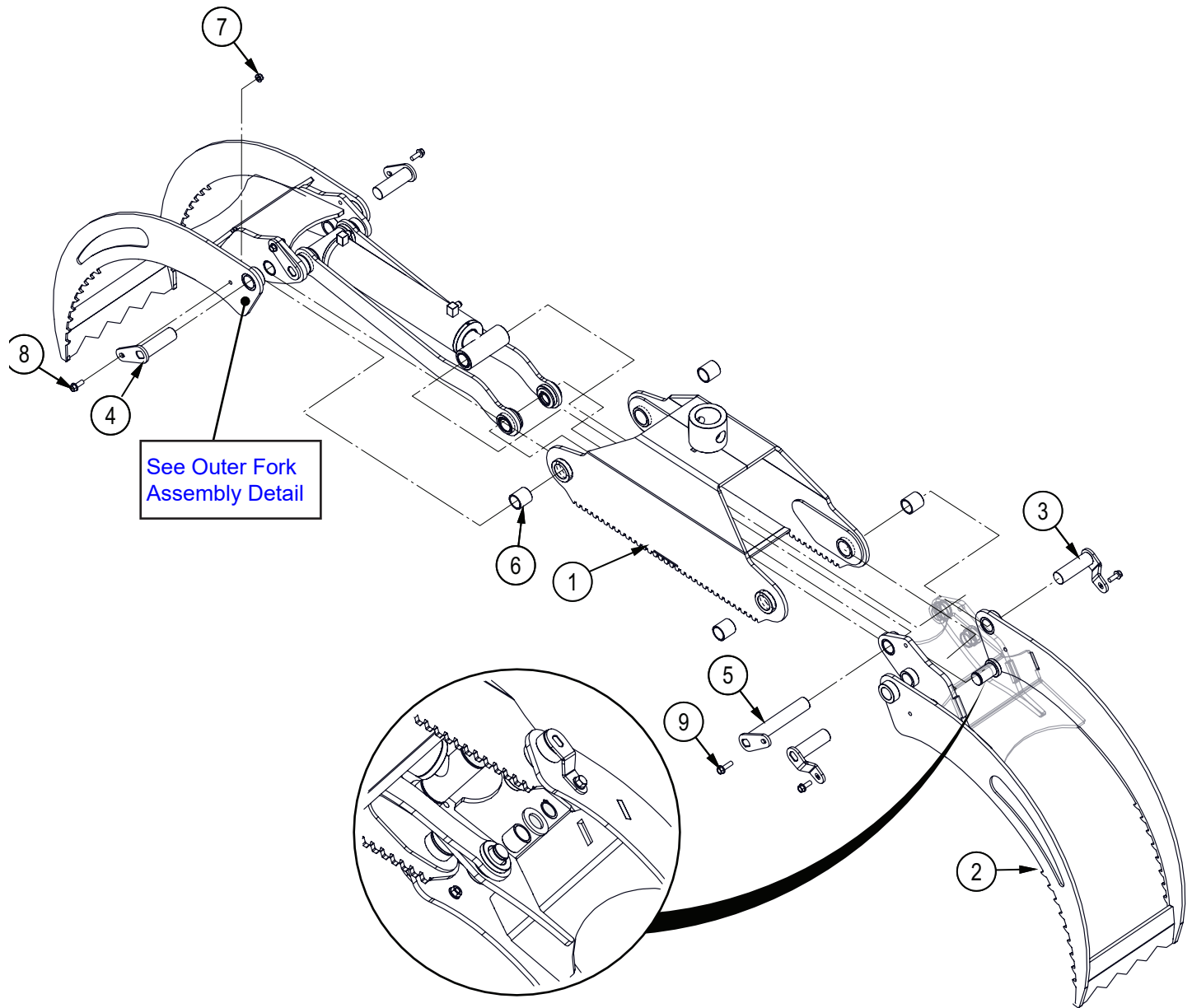

Note: See Outer Fork Assembly Detail - Items 2, 8, and 9

Item No.	Part No.	Description	Qty
1	6018W501	Grapple Housing	1
2	6018W517	Inner Fork	1
3	6018W508	Inner Fork Pin	2
4	6018W509	Outer Fork Pin	2
5	6018W510	Short Cylinder Pin	1
6	Z27107	Composite Bearing, 1-1/4" ID x 1-1/2" long x 1/8" Wall	4
7	Z72531	Serrated Flange Locknut, 3/8NC	5
8	Z76134	Flange Bolt, 3/8NC x 1"	4
9	Z76137	Flange Bolt, 3/8NC x 1-1/4"	1

Outer Fork Assembly S/N 330S001 to 330S016

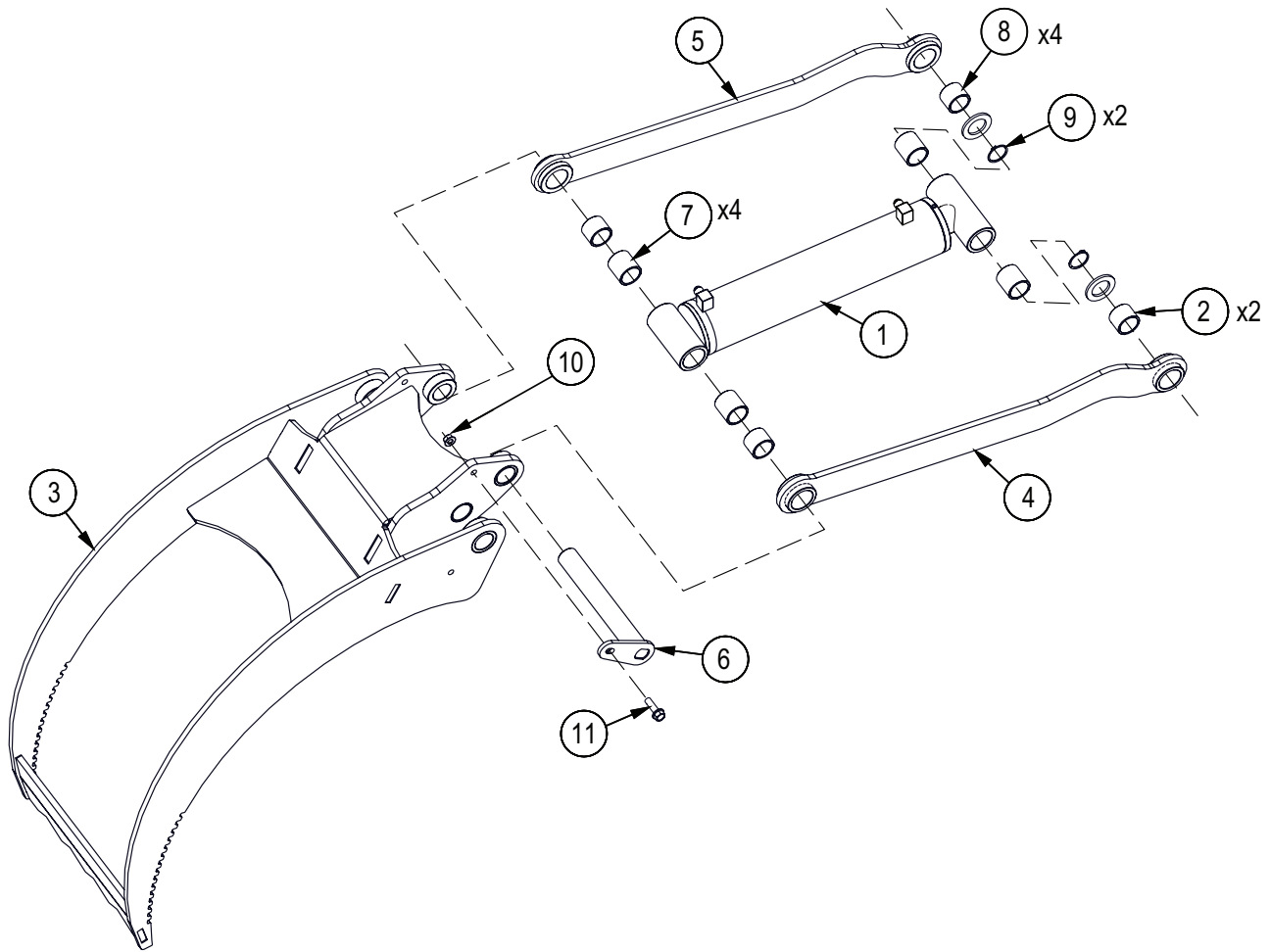

Item No.	Part No.	Description	Qty
1	6018C501	Cylinder, 3" x 1-3/4" x 12-5/8"	1
2	6018L526	Washer, Linkage Retaining	2
3	6018W503	Outer Fork	1
4	6018W504	Linkage	1
5	6018W504H	Linkage Mirror	1
6	6018W511	Long Cylinder Pin	1
7	Z27107	Composite Bearing, 1-1/4" ID x 1-1/2" long x 1/8" Wall	4
8	Z27108	Composite Bearing, 1-1/4" ID x 1-1/8" long x 1/8" Wall	4
9	Z46202	External Retaining Ring, 1-1/4"	2
10	Z72531	Serrated Flange Locknut, 3/8NC	1
11	Z76137	Flange Bolt, 3/8NC x 1-1/4"	1

Outer Fork Assembly S/N 330S017 & Up

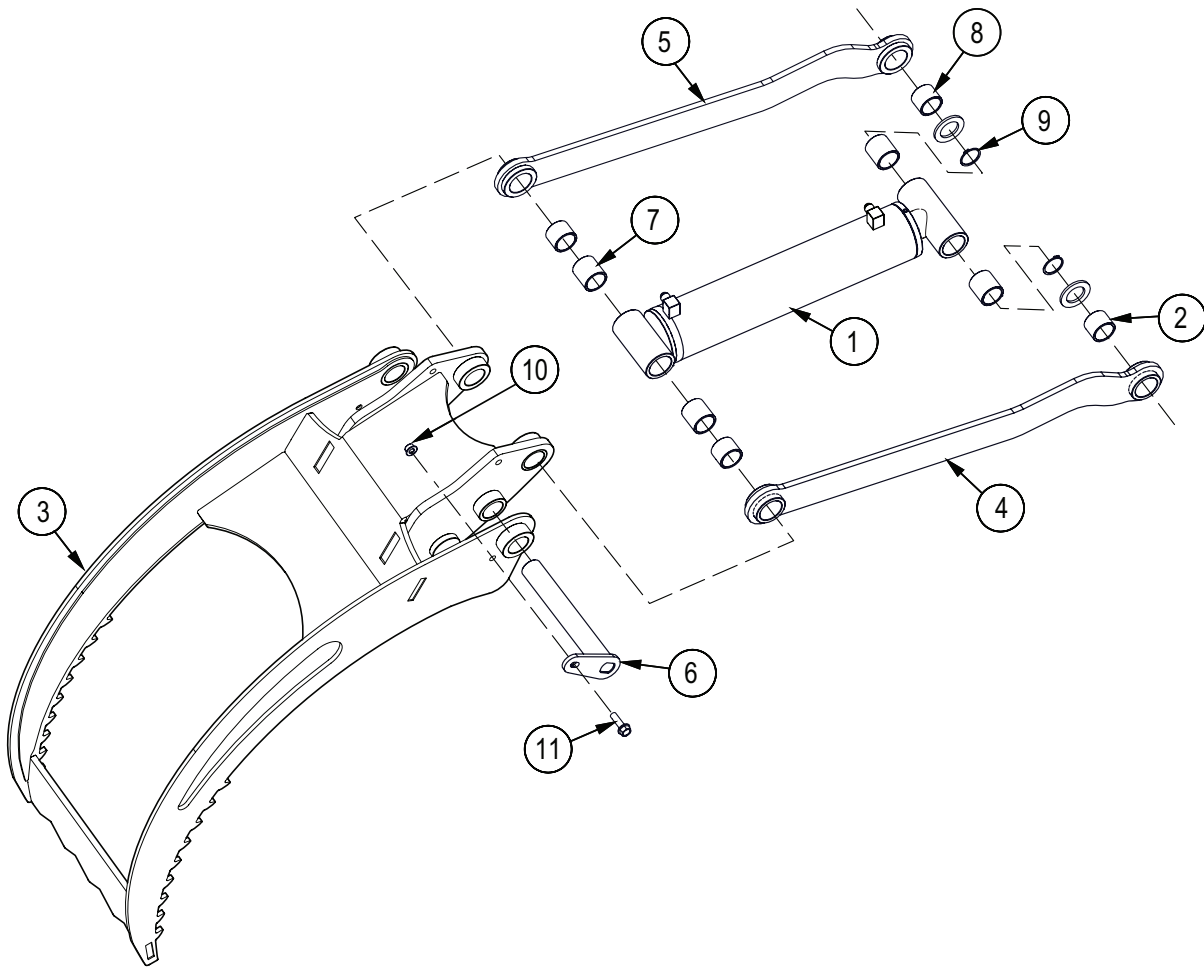

Item No.	Part No.	Description	Qty
1	6018C501	Cylinder, 3" x 1-3/4" x 12-5/8"	1
2	6018L526	Washer, Linkage Retaining	2
3	6018W518	Outer Fork	1
4	6018W504	Linkage	1
5	6018W504H	Linkage Mirror	1
6	6018W511	Long Cylinder Pin	1
7	Z27107	Composite Bearing, 1-1/4" ID x 1-1/2" long x 1/8" Wall	4
8	Z27108	Composite Bearing, 1-1/4" ID x 1-1/8" long x 1/8" Wall	4
9	Z46202	External Retaining Ring, 1-1/4"	2
10	Z72531	Serrated Flange Locknut, 3/8NC	1
11	Z76137	Flange Bolt, 3/8NC x 1-1/4"	1

Cylinder Detail

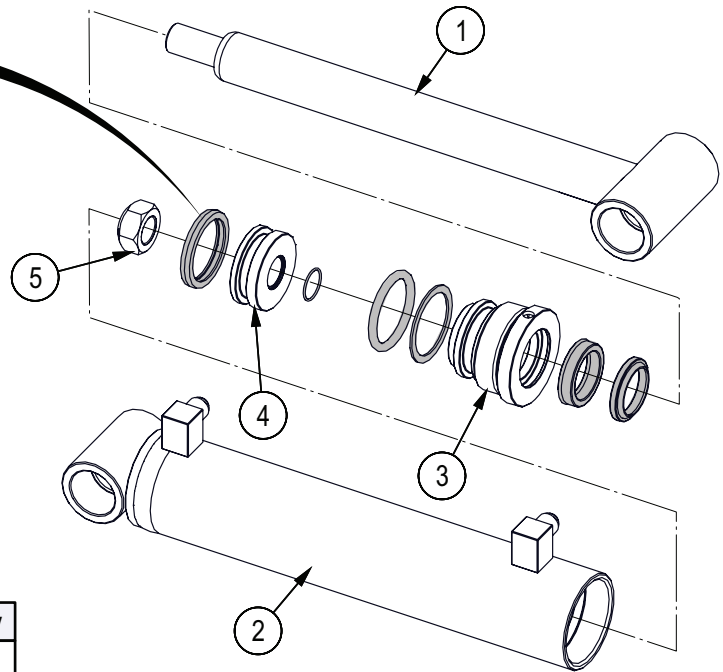

Item No.	Part No.	Description	Qty
1	6018C5013	Rod, 1-3/4" 1"	1
2	6018C5014	Barrel, 3"	1
3	G300-175S	Gland, 3" x 1-3/4"	1
4	P100-300SP	Piston, 3" Bore	1
5	Z722909G8	Hex Top-lock Nut, 1-14NF G8	1

Hydraulic Plumbing Diagram

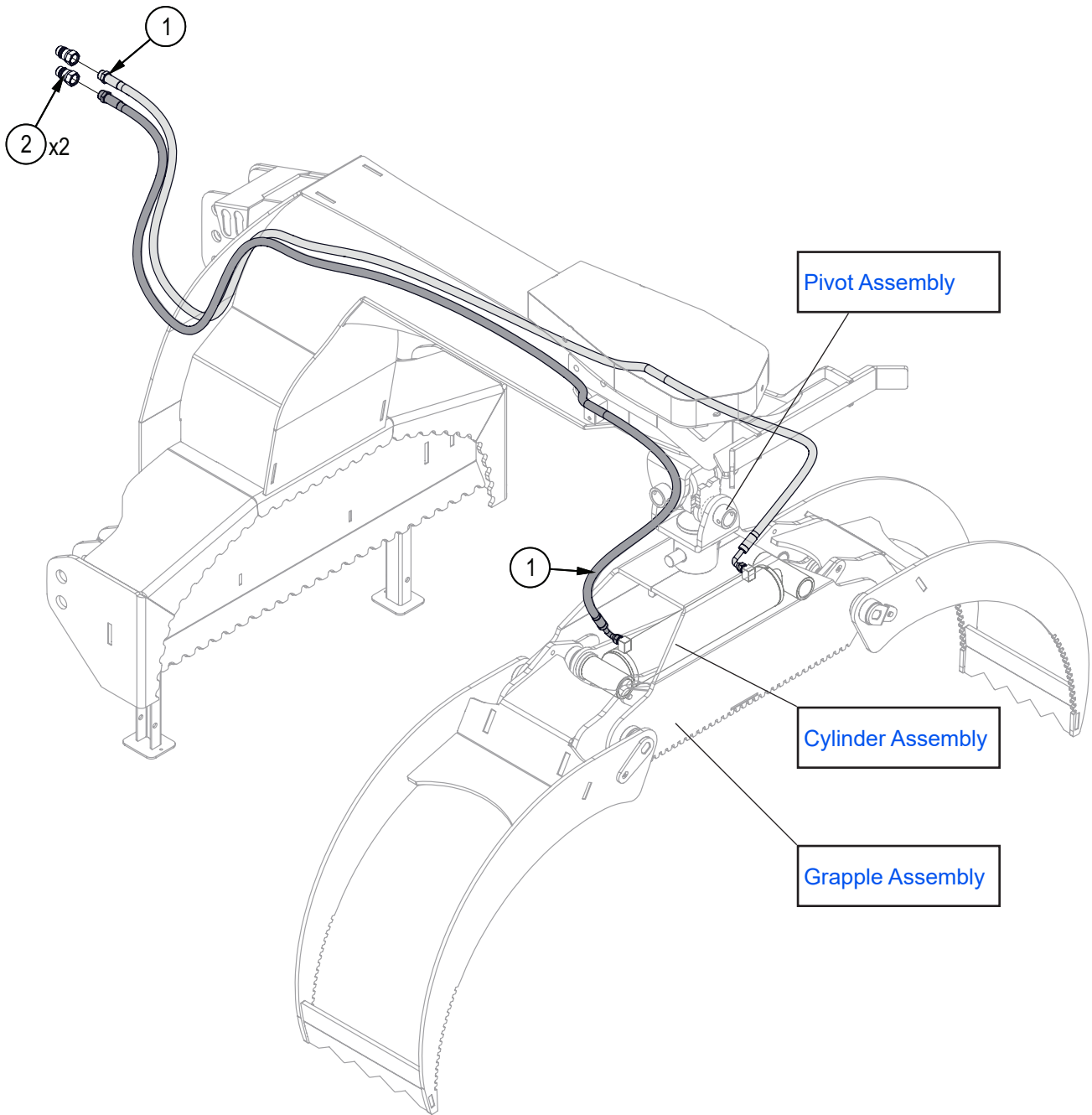

Item No.	Part No.	Description	Qty
1	6016F501	3/8" Hose, 90FJIC06 x MP08 x 116"	2
2	Z51926	Quick Coupler, FP08 x M ISO 7241-1	2

Decal Layout

IMPORTANT! If parts are replaced that have safety signs on them, new signs must be applied. Safety signs must always be replaced if they become damaged, are removed, or become illegible.

Safety signs are included in the product decal kit available from your authorized dealer. Decals are not available separately.

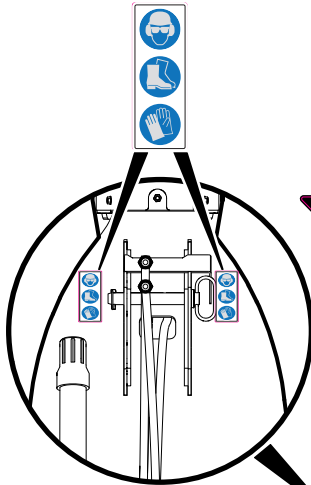
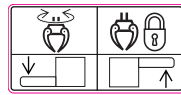

Accessories

Call your dealer for pricing and availability

	<p>#Z99001 48" LOG PEAVEY</p> <p>Quality 2 3/8" diameter hardwood handle, with a Western Duck Bill Hook. Helps to move those heavy log timbers into position.</p>
	<p>#Z99003 SKIDDING TONGS</p> <p>Heavy Duty Forged Ring Skidding Tongs Maximum Opening: 25" Minimum Opening: 4-1/2" Tough log skidding tongs are a quick and easy way to skid logs.</p>

Common Bolt Torque Values

Checking Bolt Torque

The tables shown give correct torque values for various bolts and capscrews. Tighten all bolts to the torque values specified in the table, unless indicated otherwise. Check tightness of bolts periodically.

IMPORTANT! If replacing hardware, use fasteners of the same grade.

IMPORTANT! Torque figures indicated in the table are for non-greased or non-oiled threads. Do not grease or oil threads unless indicated otherwise. When using a thread locker, increase torque values by 5%.

 **NOTE:** Bolt grades are identified by their head markings.

Imperial Bolt Torque Specifications

Bolt Diameter	Torque Value					
	SAE Gr. 2		SAE Gr. 5		SAE Gr. 8	
	lbf•ft	N•m	lbf•ft	N•m	lbf•ft	N•m
1/4"	6	8	9	12	12	17
5/16"	10	13	19	25	27	36
3/8"	20	27	33	45	45	63
7/16"	30	41	53	72	75	100
1/2"	45	61	80	110	115	155
9/16"	60	95	115	155	165	220
5/8"	95	128	160	215	220	305
3/4"	165	225	290	390	400	540
7/8"	170	230	420	570	650	880
1"	225	345	630	850	970	1320



SAE Gr. 2



SAE Gr. 5



SAE Gr. 8

Metric Bolt Torque Specifications

Bolt Diameter	Torque Value			
	Gr. 8.8		Gr. 10.9	
	lbf•ft	N•m	lbf•ft	N•m
M3	0.4	0.5	1.3	1.8
M4	2.2	3	3.3	4.5
M6	7	10	11	15
M8	18	25	26	35
M10	37	50	52	70
M12	66	90	92	125
M14	83	112	116	158
M16	166	225	229	310
M20	321	435	450	610
M30	1,103	1 495	1,550	2 100



8.8



10.9

Hydraulic Fitting Torque Values

Tightening Flare Type Tube Fittings

1. Check flare and flare seat for defects that might cause leakage.
2. Align tube with fitting before tightening.
3. Hand-tighten swivel nut until snug.
4. To prevent twisting the tube, use two wrenches. Place one wrench on the connector body and tighten the swivel nut with the second. Torque to values shown.

If a torque wrench is not available, use the FFFT (Flats From Finger Tight) method.

Hydraulic Fitting Torque					
Tube Size OD	Hex Size Across Flats	Torque value		Flats From Finger Tight	
		lbf•ft	N•m	Flats	Turns
3/16	7/16	6	8	2	1/6
1/4	9/16	11–12	15–17	2	1/6
5/16	5/8	14–16	19–22	2	1/6
3/8	11/16	20–22	27–30	1-1/4	1/6
1/2	7/8	44–48	59–65	1	1/6
5/8	1	50–58	68–79	1	1/6
3/4	1-1/4	79–88	107–119	1	1/8
1	1-5/8	117–125	158–170	1	1/8

Values shown are for non-lubricated connections.