

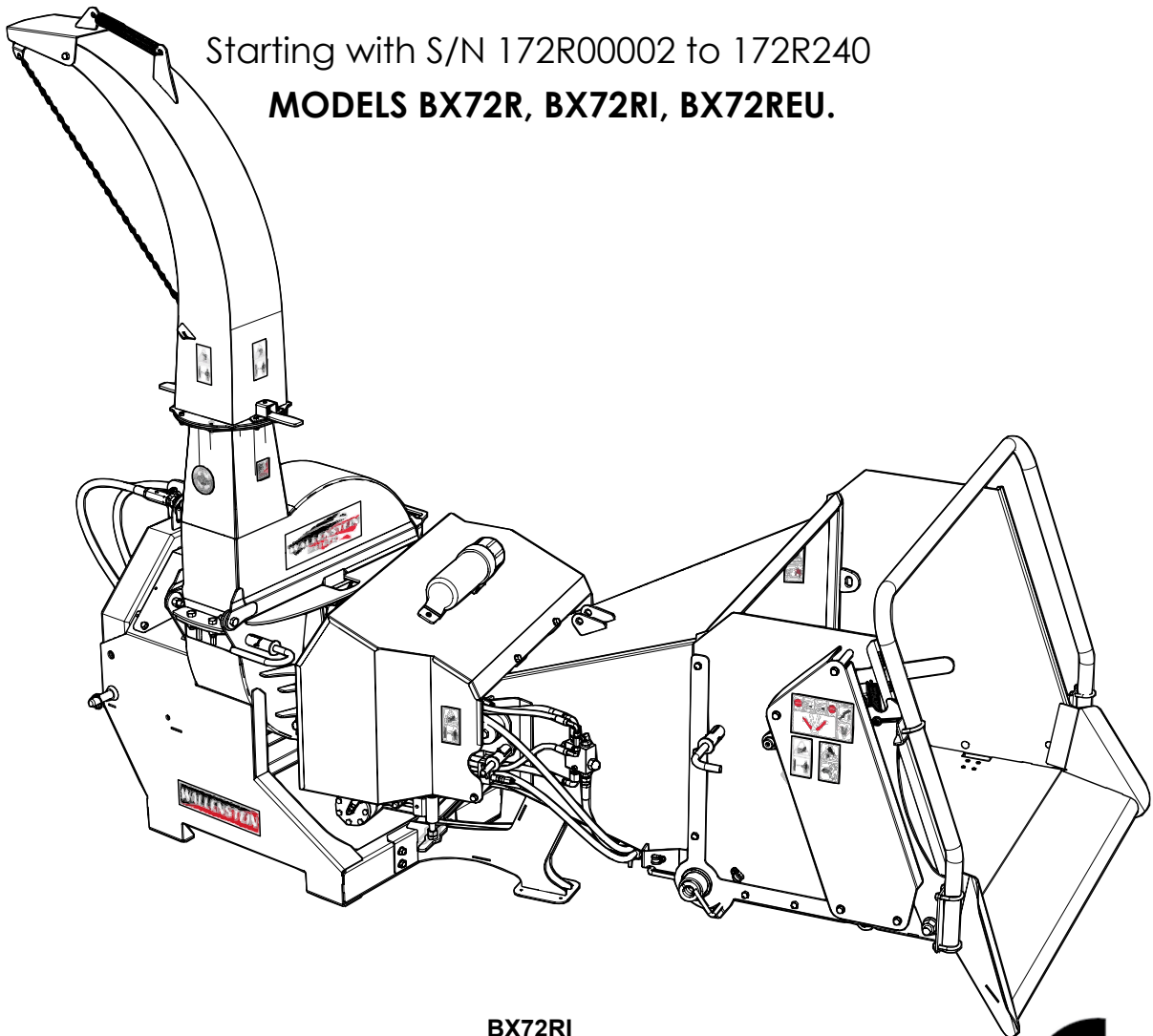

EMB Manufacturing Inc.  
4144 Boomer Line · St. Clements, On · N0B 2M0 · Canada  
Ph: (519) 699-9283 · Fax: (519) 699-4146  
www.wallensteinequipment.com

# BX72 Series 3 Point Hitch Chipper Parts Manual

Starting with S/N 172R00002 to 172R240  
**MODELS BX72R, BX72RI, BX72REU.**



**BX72RI**



Refer to the operators  
manual for safe opera-  
tion and maintenance



1023T100 BX72R RevB Parts Manual.091214  
Rev # 130417

# Table of Contents

Contents	
<b>BX72 VARIATION CHART .....</b>	<b>3</b>
<b>BOLT TORQUE .....</b>	<b>4</b>
<b>HYDRAULIC FITTING TORQUE.....</b>	<b>5</b>
<b>ROTOR ASS'Y.....</b>	<b>6</b>
<b>BASE ASS'Y .....</b>	<b>7</b>
<b>CHUTE &amp; GUARD ASS'Y .....</b>	<b>8</b>
<b>UPPER ROLLER ASS'Y .....</b>	<b>9</b>
<b>LOWER ROLLER ASS'Y .....</b>	<b>10</b>
<b>HOPPER ASS'Y (TOP VIEW) .....</b>	<b>11</b>
<b>BYPASS VALVE DETAIL .....</b>	<b>11</b>
<b>HOPPER ASS'Y (BOTTOM VIEW) .....</b>	<b>12</b>
<b>FEED TABLE ASS'Y .....</b>	<b>13</b>
<b>MANUAL FEED ROLLER CONTROL DETAIL .....</b>	<b>14</b>
<b>FEED ROLLER CONTROL DETAIL .....</b>	<b>14</b>
<b>INTELLIFEED ROLLER CONTROL DETAIL.....</b>	<b>15</b>
<b>INTELLIFEED COMPONENTS .....</b>	<b>15</b>
<b>PTO SHAFT #Z44504 .....</b>	<b>16</b>
<b>INTELLIFEED SETTINGS .....</b>	<b>17</b>
<b>INTELLIFEED WIRING DIAGRAM #Z62109 .....</b>	<b>18</b>
<b>HYDRAULIC HOSE PARTS LIST .....</b>	<b>19</b>
<b>HYDRAULIC SCHEMATIC BX72R .....</b>	<b>20</b>
<b>HYDRAULIC SCHEMATIC BX72RI .....</b>	<b>21</b>
<b>LABELS - LEFT SIDE VIEW .....</b>	<b>22</b>
<b>LABELS - RIGHT SIDE VIEW .....</b>	<b>23</b>

## Foreword

EMB Mfg. has prepared this parts manual to assist customers in ordering quality OEM replacement parts.

Proper and regular service and replacing old, worn or broken parts with the correct Wallenstein parts are essential to prolonging the life of your Wallenstein product. Please refer to this manual before ordering any replacement parts.

All information contained in this parts manual is based on the latest product specification available at the time of printing this manual. If your product differs from the specifications contained within this manual contact EMB Mfg. for information.

EMB reserves the right to alter specifications on their products at any time.

Reproduction of this parts manual of any kind is prohibited without prior written permission from EMB Mfg.

For parts and information please contact your dealer. If your dealer is no longer available please go to our website: <http://www.embmfg.com> and click on "FIND A DEALER NEAR YOU" for information on a local dealer.

**BX72 Variation Chart**

BX Option Cross Reference			Option	
			Intellifeed	Revision Level
<b>Model</b>	BX72REU	BX72R		B
		BX72RI	X	B

**Bolt Torque**

**CHECKING BOLT TORQUE**

The tables shown below give correct torque values for various bolts and capscrews. Tighten all bolts to the torques specified in chart unless otherwise noted. Check tightness of bolts periodically, using bolt torque chart as a guide. Replace hardware with the same strength bolt.

Torque figures indicated above are valid for non-greased or non-oiled threads and heads unless otherwise specified. Therefore, do not grease or oil bolts or capscrews unless otherwise specified in this manual. When using locking elements, increase torque values by 5%.

\* Torque value for bolts and capscrews are identified by their head markings.

**ENGLISH TORQUE SPECIFICATIONS**

Bolt Diameter "A"	Bolt Torque*					
	SAE 2 (N.m) (lb-ft)		SAE 5 (N.m) (lb-ft)		SAE 8 (N.m) (lb-ft)	
1/4"	8	6	12	9	17	12
5/16"	13	10	25	19	36	27
3/8"	27	20	45	33	63	45
7/16"	41	30	72	53	100	75
1/2"	61	45	110	80	155	115
9/16"	95	60	155	115	220	165
5/8"	128	95	215	160	305	220
3/4"	225	165	390	290	540	400
7/8"	230	170	570	420	880	650
1"	345	225	850	630	1320	970



**METRIC TORQUE SPECIFICATIONS**

Bolt Diameter "A"	Bolt Torque*			
	8.8 (N.m) (lb-ft)		10.9 (N.m) (lb-ft)	
M3	.5	.4	1.8	1.3
M4	3	2.2	4.5	3.3
M5	6	4	9	7
M6	10	7	15	11
M8	25	18	35	26
M10	50	37	70	52
M12	90	66	125	92
M14	140	103	200	148
M16	225	166	310	229
M20	435	321	610	450
M24	750	553	1050	774
M30	1495	1103	2100	1550
M36	2600	1917	3675	2710

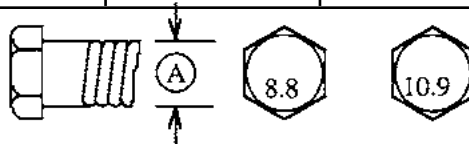

**Hydraulic Fitting Torque**

**Tightening Flare Type Tube Fittings \***

1. Check flare and flare seat for defects that might cause leakage.
2. Align tube with fitting before tightening.
3. Lubricate connection and hand tighten swivel nut until snug.
4. To prevent twisting the tube(s), use two wrenches. Place one wrench on the connector body and with the second tighten the swivel nut to the torque shown.

Tube Size OD (in.)	Nut Size Across Flats (in.)	Torque Value*		Recommended Turns To Tighten (After Finger Tightening)	
		(N.m)	(lb-ft)	(Flats)	(Turn)
3/16	7/16	8	6	1	1/6
1/4	9/16	12	9	1	1/6
5/16	5/8	16	12	1	1/6
<b>3/8</b>	<b>11/16</b>	<b>24</b>	<b>18</b>	<b>1</b>	<b>1/6</b>
1/2	7/8	46	34	1	1/6
5/8	1	62	46	1	1/6
3/4	1-1/4	102	75	3/4	1/8
7/8	1-3/8	122	90	3/4	1/8

The torque values shown are based on lubricated connections as in reassembly.

MODELS BX72R, BX72RI

Rotor Ass'y

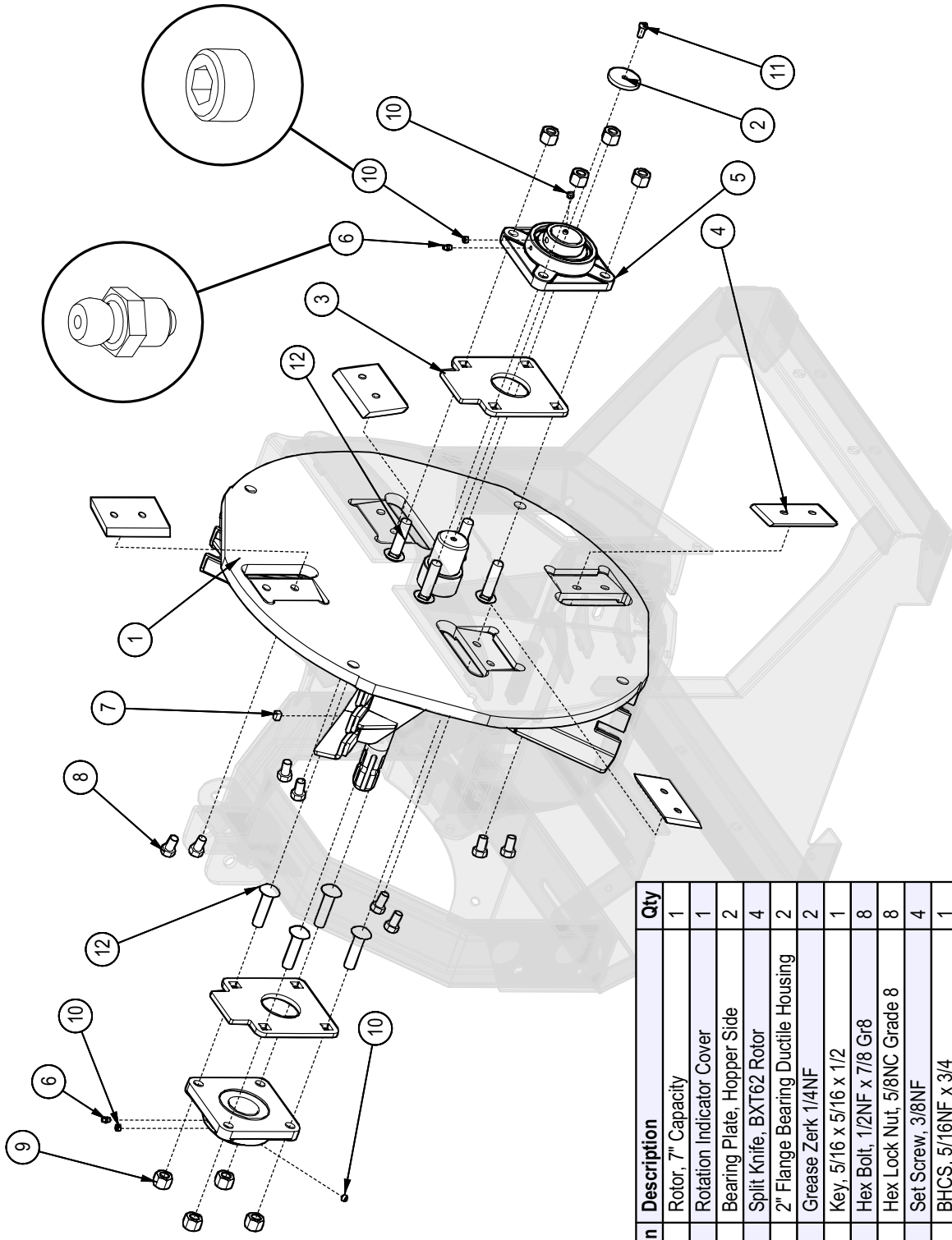

BOM ID	Description	Description	Qty
1	1023W101	Rotor, 7" Capacity	1
2	1021S102	Rotation Indicator Cover	1
3	1023L145	Bearing Plate, Hopper Side	2
4	1053M303	Split Knife, BXT62 Rotor	4
5	Z25208	2" Flange Bearing Ductile Housing	2
6	Z29202	Grease Zerk 1/4NF	2
7	Z46545	Key, 5/16 x 5/16 x 1/2	1
8	Z71572G8	Hex Bolt, 1/2NF x 7/8 Gr8	8
9	Z72261G8	Hex Lock Nut, 5/8NC Grade 8	8
10	Z74132	Set Screw, 3/8NF	4
11	Z75351	BHCS, 5/16NF x 3/4	1
12	Z76264G8	Carriage Bolt, 5/8NC x 2-1/2 Grade 8	8

MODELS BX72R, B72RI

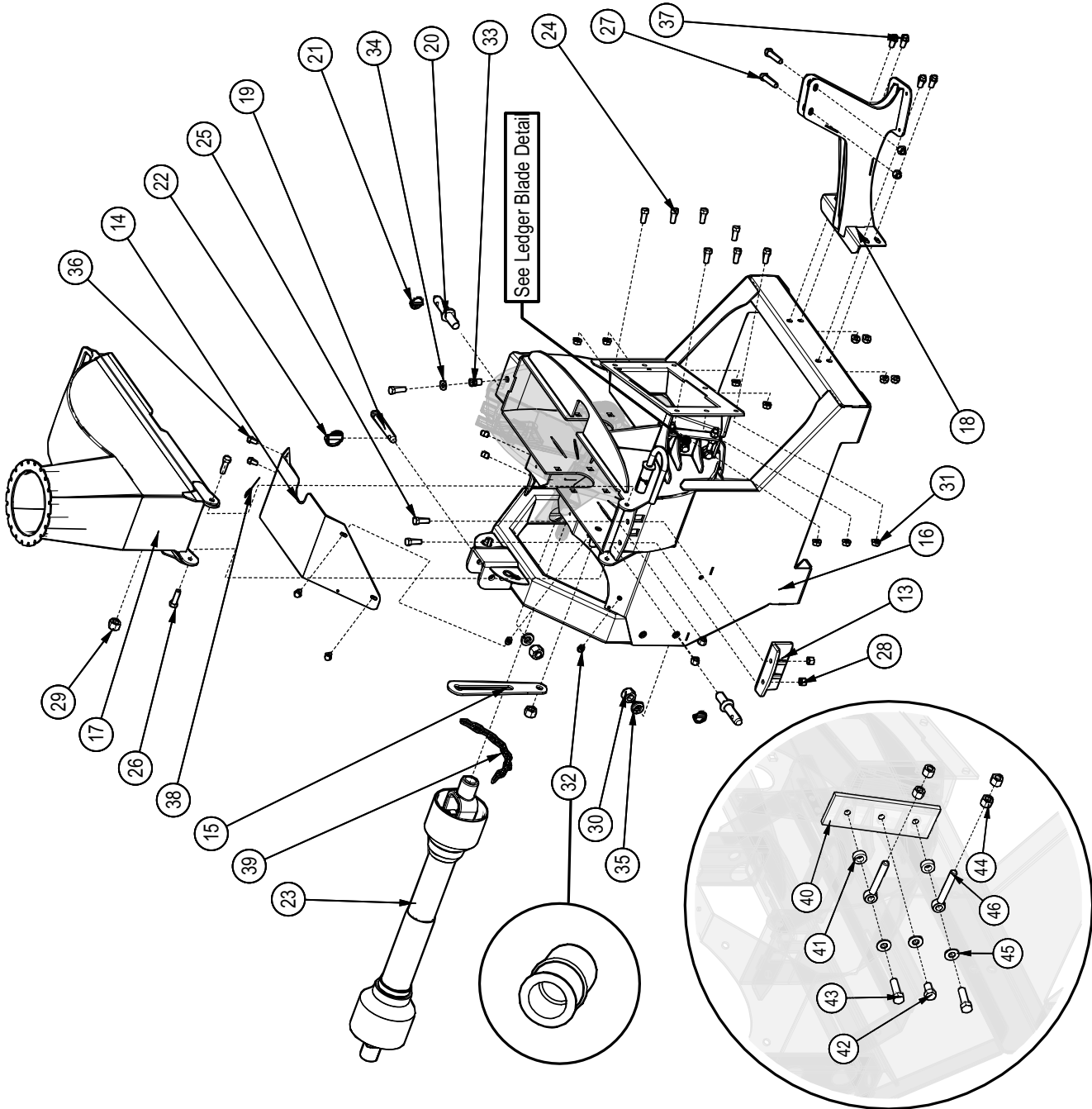

**Base Ass'y**

BOM ID	Description	Description	Qty
13	1012M204	Twig Breaker	1
14	1023L153	PTO Shield	1
15	1023L155	Rotation Stop	1
16	1023W102	Lower Housing Weldment	1
17	1023W103	Weldment, Upper Housing	1
18	1023W104	Hopper Support Weldment	1
19	Z11122	Toplink Pin 3/4 x 3-7/8	1
20	Z11431	Implement Pin 7/8x5-1/2	2
21	Z12110	Latch Pin 3/16	2
22	Z12140	Latch Pin 7/16	1
23	Z44504	#5 Global PTO Shaft M10 Shear	1
24	Z71512	Hex Bolt, 1/2NC x 1-1/4	7
25	Z71515	Hex Bolt, 1/2NC x 1-1/2	2
26	Z71517	Hex Bolt, 1/2NC x 1-3/4	3
27	Z71527	Hex Bolt, 1/2NC x 2-3/4	2
28	Z72251	Hex Lock Nut, 1/2NC	6
29	Z72271	Hex Lock Nut, 3/4NC	2
30	Z72282	Hex Lock Nut, 7/8-14NF	2
31	Z72551	Flange Nut 1/2NC	11
32	Z72959	Riv-Nut 3/8NC x 312	4
33	Z72961	Riv-Nut 1/2NC x 350	1
34	Z73151	Flat Washer, 1/2	3
35	Z73381	Lock Washer, 7/8	2
36	Z76133	Flange Bolt, 3/8NC x 3/4	4
37	Z76153	Flange Bolt, 1/2NC x 1	4
38	Z92110	1/16 Aircraft cable x 2'	1
39	Z92310	Chain 3/16" x 12" double hook ends	1
40	1012M204	Knife, BX62 Ledger	1
41	1023L150	Ledger Washer	2
42	Z71572G8	Hex Bolt, 1/2NF x 7/8 Gr8	1
43	Z71579G8	Hex Bolt, 1/2NF x 1-3/4 Gr8	2
44	Z72251	Hex Lock Nut, 1/2NC	4
45	Z73151	Flat Washer, 1/2	3
46	Z76553	Rod End, 1/2NC x 3-1/2" Full Threads	2

MODELS BX72R, B72RI

Chute & Guard Ass'y

BOM ID	Description	Description	Qty
47	1012W205	Discharge Deflector	1
48	1012W206	Discharge Chute	1
49	1012W208	Assembly, Hood Latch	1
50	1023W221	Bridge Guard	1
51	1012L229	Spacer Ring	2
52	1012L230	Hood Capture Ring	2
53	1082L422	BX62 rotation limiting tab	1
54	Z31403	Spring 27mm x 178mm x 0.105	1
55	Z71110	Hex Bolt, 1/4NC x 1	8
56	Z72211	Hex Lock Nut, 1/4NC	11
57	Z72911	Acorn Nut, 3/8NC	2
58	Z76133	Flange Bolt, 3/8NC x 3/4	8
59	Z78301	Machine Screw, 1/4-20NC x 3/4	3
60	Z92304	Single-Jack Chain #10 [35 links]	1
61	Z96503	Manual Tube 3-1/2 Short	1

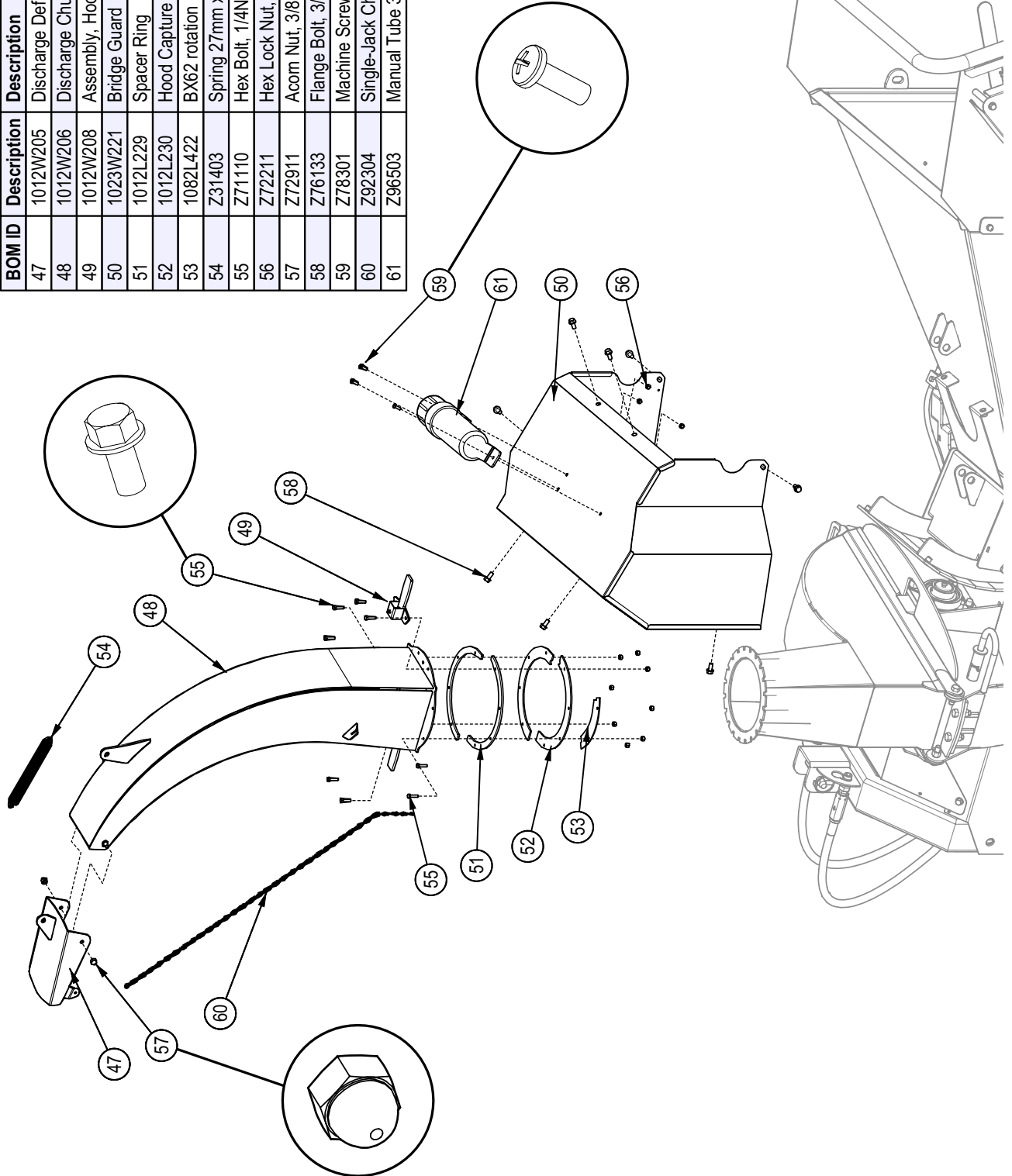



MODELS BX72R, B72RI

Upper Roller Ass'y

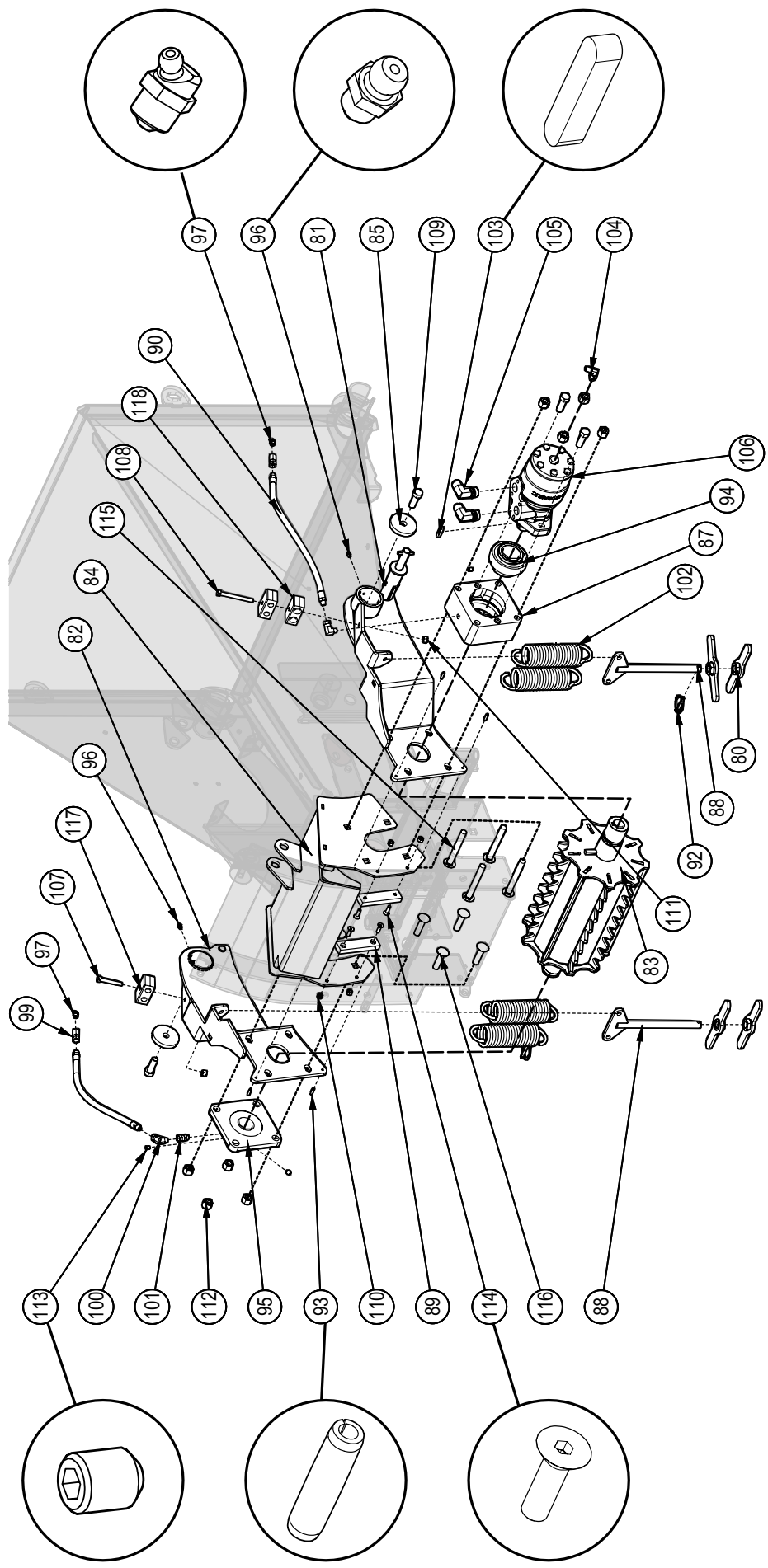

BOM ID	Description	Qty
80	1022W220 Nut Handle	4
81	1023W202 Weldment, Roller Pivot Arm LH	1
82	1023W202H Weldment, Roller Pivot Arm RH	1
83	1023W213 Upper Feed Roller	1
84	1023W218 Bridge	1
85	1015L618 Capture Washer	2
87	1022M218 UC Motor Bearing Housing	1
88	1022M222 Easy/Start Pin	2
89	1022S208 Rotor Hood Slide	2
90	Z29312-13 1/4 Grease Hose, MP02 x MP02 x 13"	2
92	Z12110 Latch Pin 3/16	2
93	Z14152 Roll Pin, 3/16 x 3/4	4
94	Z21903 Ball Bearing Insert 1-3/4"	1

BOM ID	Description	Qty
95	Z25204 4-Bolt Bearing 1-1/2" Bore	1
96	Z29202 Grease Zerk 1/4NF	2
97	Z29204 Grease Fitting, 1/8NPT x 45	2
99	Z29302 Straight, FP x FFX 0202	2
100	Z29307 Elbow 90 MP x FFX 0202	2
101	Z29311 Straight, MP x FFX 0202	1
102	Z31501 Spring 2 x 7 Heavy	4
103	Z46594 Blind Chipper Key 1/4 x 1-1/4	1
104	Z51657 Elbow 90, MORB x MJIC 0404	1
105	Z51658 Elbow 90 MJIC x MORB 0810	2
106	Z54104 315 Series Hydraulic Motor	1
107	Z11220 Hex Bolt, 5/16NC x 2	1
108	Z71230 Hex Bolt, 5/16NC x 3	1

BOM ID	Description	Description	Qty
109	Z71515 Hex Bolt, 1/2NC x 1-1/2		4
110	Z72211 Hex Lock Nut, 1/4NC		4
111	Z72221 Hex Lock Nut, 5/16NC		2
112	Z72251 Hex Lock Nut, 1/2NC		8
113	Z74122 Set Screw, 5/16NF		3
114	Z75211 FHCS, 1/4NC x 7/8		4
115	Z762511 Carriage Bolt, 1/2NC x 4		4
116	Z76255 Carriage Bolt, 1/2NC x 2		4
117	Z79462 Double Hose Clamp 1/2"		2
118	Z79463 Double Hose Clamp 1 1/16"		1

MODELS BX72R, B72RI

Lower Roller Ass'y

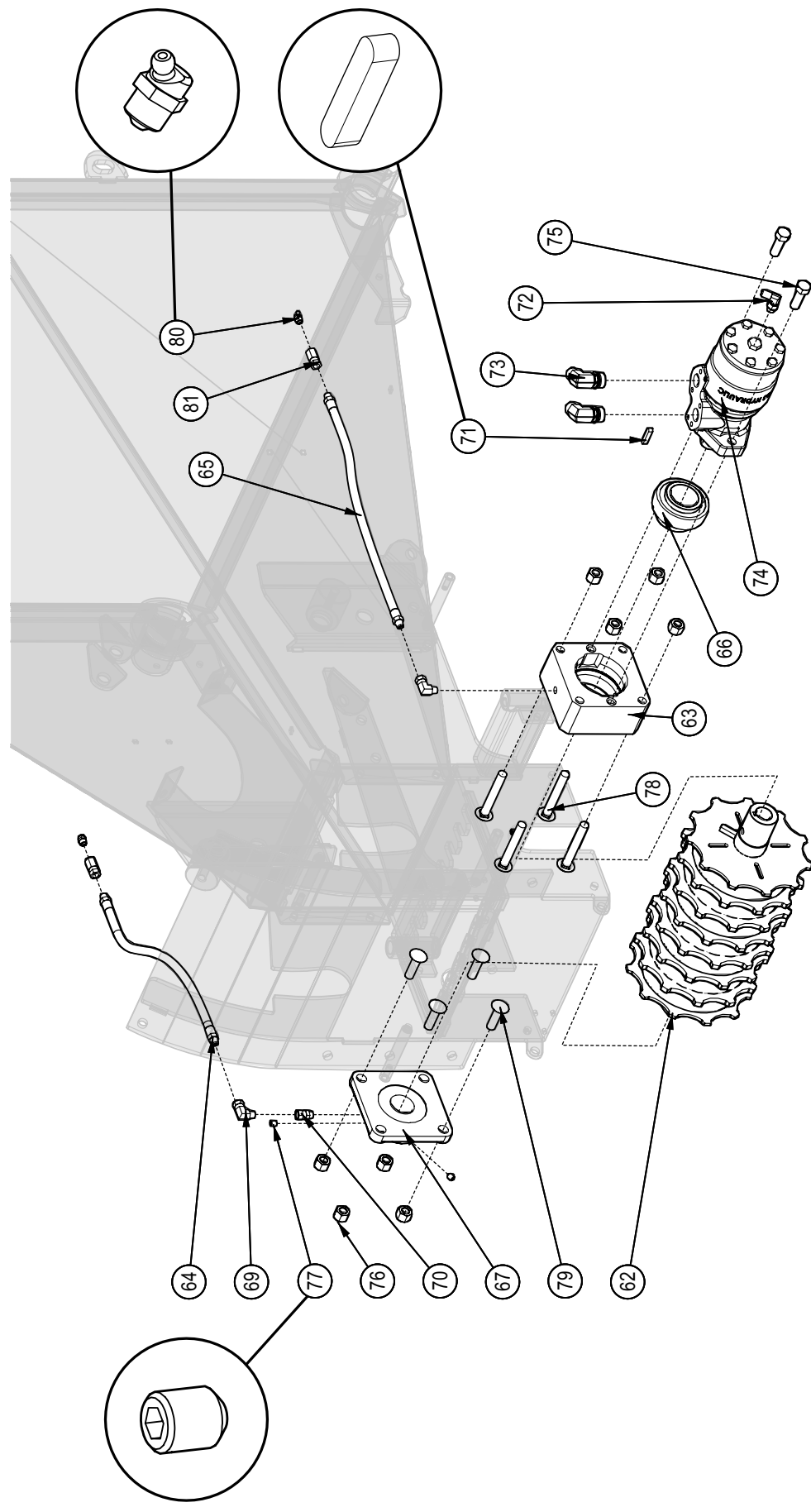

BOM ID	Description	Qty
62	1023W205 Lower Feed Roll	1
63	1022M218 UC Motor Bearing Housing	1
64	Z29313-15 1/4 Grease Hose, MP02 x MP02 x 15"	1
65	Z29313-16 1/4 Grease Hose, MP02 x MP02 x 16"	1
66	Z21903 Ball Bearing Insert 1-3/4"	1
67	Z25204 4-Bolt Bearing 1-1/2" Bore	1
69	Z29307 Elbow 90 MP x FPX 0202	2

BOM ID	Description	Qty
70	Z29311 Straight, MP x FPX 0202	1
71	Z46594 Blind Chipper Key 1/4 x 1-1/4	1
72	Z51657 Elbow 90, MORB x MJIC 0404	1
73	Z51658 Elbow 90 MJIC x MORB 0810	2
74	Z54104 315 Series Hydraulic Motor	1
75	Z71515 Hex Bolt, 1/2NC x 1-1/2	2
76	Z72251 Hex Lock Nut, 1/2NC	8

BOM ID	Description	Description	Qty
77	Z74122 Set Screw, 5/16NF		3
78	Z762510 Carriage Bolt, 1/2NC x 3-1/2		4
79	Z76258 Carriage Bolt, 1/2NC x 1-3/4		4
80	Z29204 Grease Fitting, 1/8NPT x 45		2
81	Z29302 Straight, FP x FPX 0202		2

Hopper Ass'y (top view)

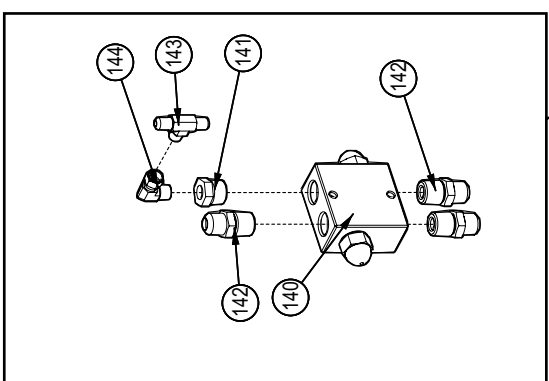
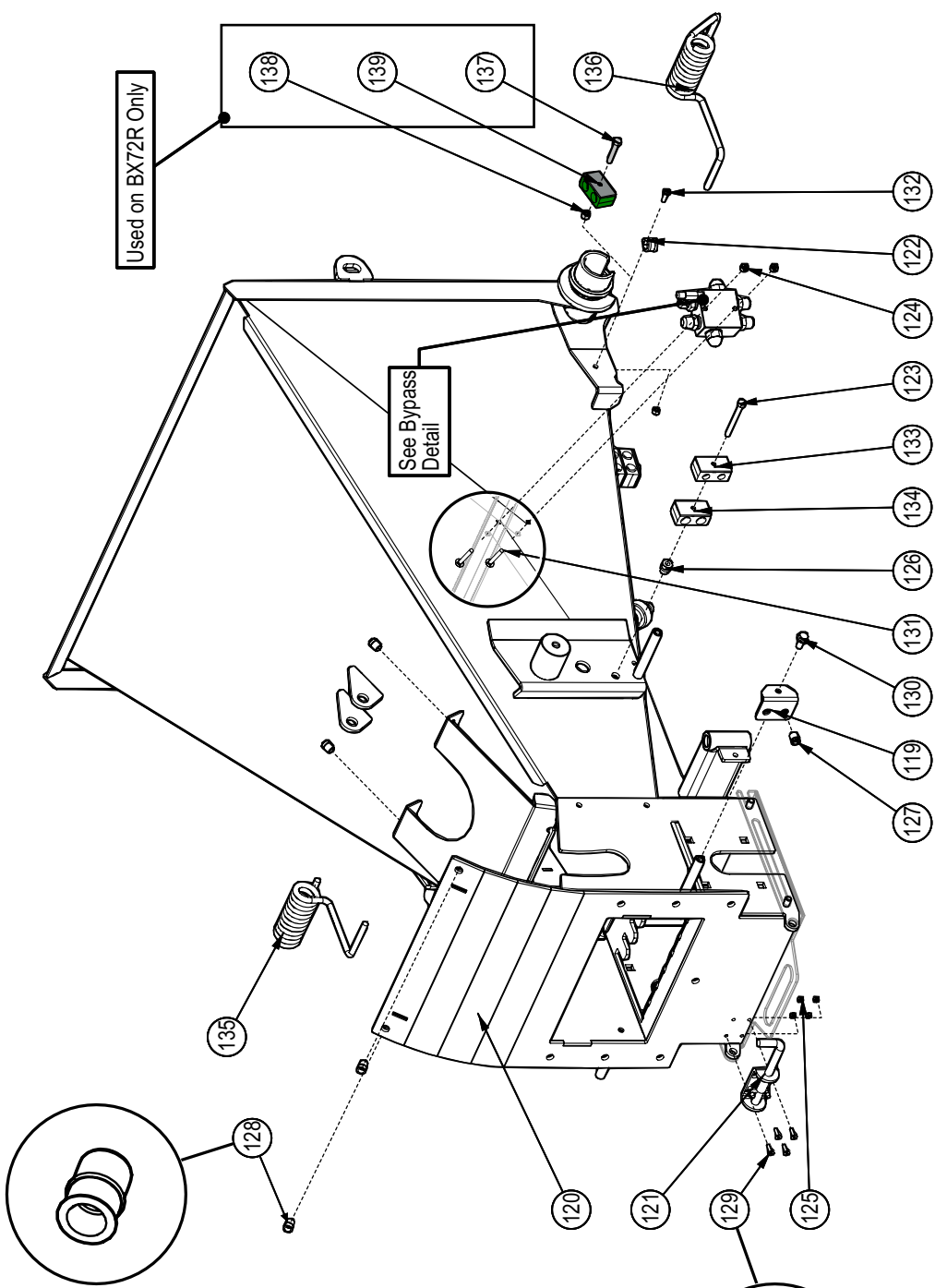

BOM ID	Description	Description	Qty
137	Z71217	Hex Bolt, 5/16NC x 1-3/4	1
138	Z72221	Hex Lock Nut, 5/16NC	1
139	Z79463	Double Hose Clamp 11/16"	1
140	Z56401	Crossover Relief Valve	1
141	Z51442	#8 JIC x 1/2NPT	3
142	Z51488	Tee MJIC x MJIC x MJIC 040404	1
143	Z51522	Elbow 90 MP x FJICX 0404	1

BOM ID	Description	Description	Qty
128	Z72959	Riv-Nut 3/8NC x 3/2	2
129	Z75203	FHCS, #10-32NF x 3/4	4
130	Z76133	Flange Bolt, 3/8NC x 3/4	1
131	Z76213	Carriage Bolt, 1/4NC x 2	2
132	Z78301	Machine Screw, 1/4-20NC x 3/4	1
133	Z79462	Double Hose Clamp 1/2"	1
134	Z79463	Double Hose Clamp 11/16"	1
135	Z33301	Torsion Spring 3/8wire x 2 O.D. x 5" RH	1
136	Z33302	Torsion Spring 3/8wire x 2 O.D. x 5" LH	1

BOM ID	Description	Description	Qty
119	1023L300	Bridge Guard Mount	1
120	1023W201	Main Hopper Weldment	1
121	Z18207	Spring Latch Pin 1/2 x 1" Stroke	1
122	Z62819	Rubberized Wire Clamp, 1/2"	1
123	Z71230	Hex Bolt, 5/16NC x 3	1
124	Z72211	Hex Lock Nut, 1/4NC	3
125	Z72752	Machine Nut, #10-32NF	4
126	Z72957	Riv-Nut 5/16NC x 3/2	1
127	Z72958	Riv-Nut 3/8NC x 150	3

MODELS BX72R, B72RI

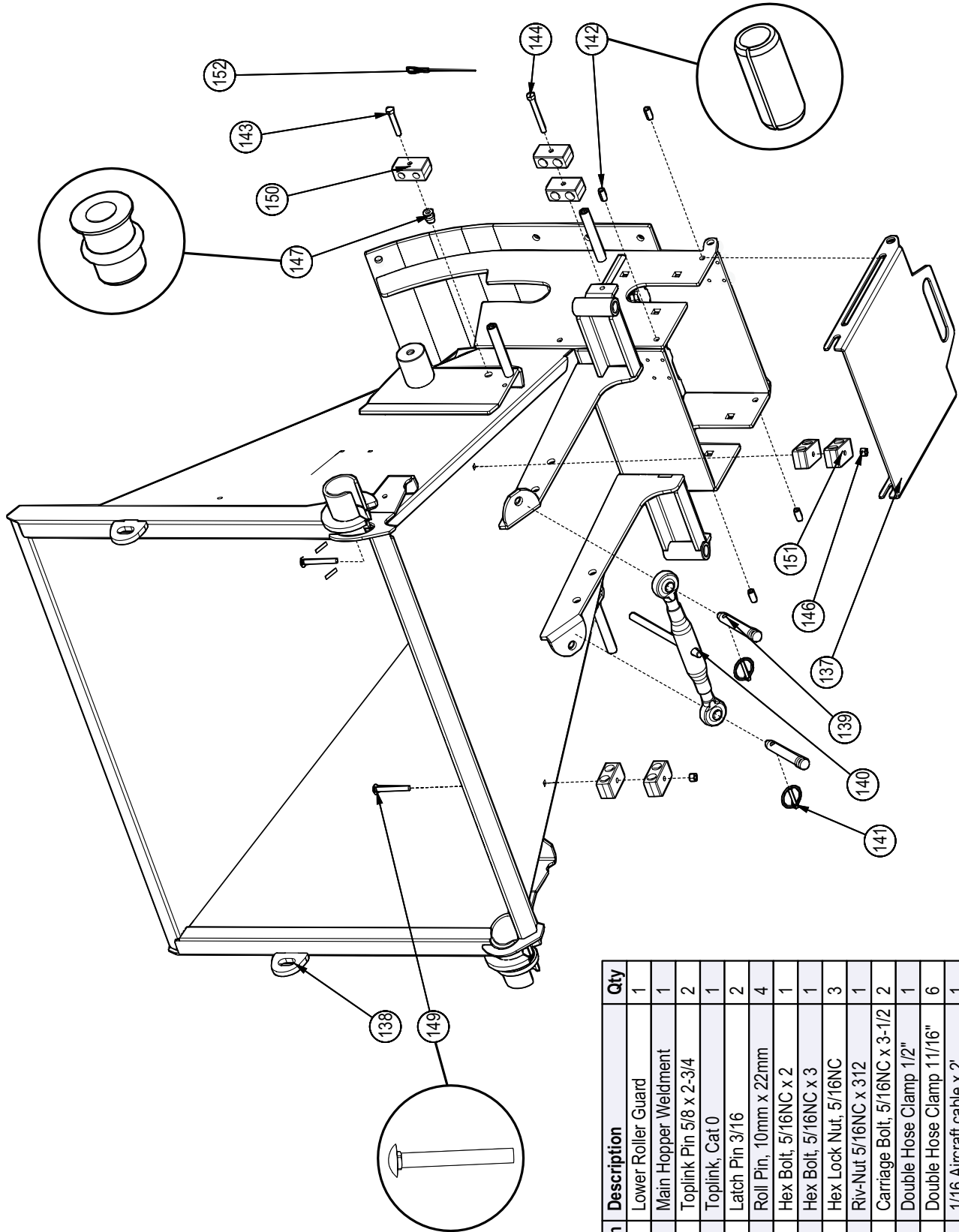

Hopper Ass'y (bottom view)

BOM ID	Description	Description	Qty
137	1023L280	Lower Roller Guard	1
138	1023W201	Main Hopper Weldment	1
139	Z11111	Toplink Pin 5/8 x 2-3/4	2
140	Z11501	Toplink, Cat 0	1
141	Z12110	Latch Pin 3/16	2
142	Z14301	Roll Pin, 10mm x 22mm	4
143	Z71220	Hex Bolt, 5/16NC x 2	1
144	Z71230	Hex Bolt, 5/16NC x 3	1
146	Z72221	Hex Lock Nut, 5/16NC	3
147	Z72957	Riv-Nut 5/16NC x 312	1
149	Z76229	Carriage Bolt, 5/16NC x 3-1/2	2
150	Z79462	Double Hose Clamp 1/2"	1
151	Z79463	Double Hose Clamp 1 1/16"	6
152	Z92110	1/16 Aircraft cable x 2'	1

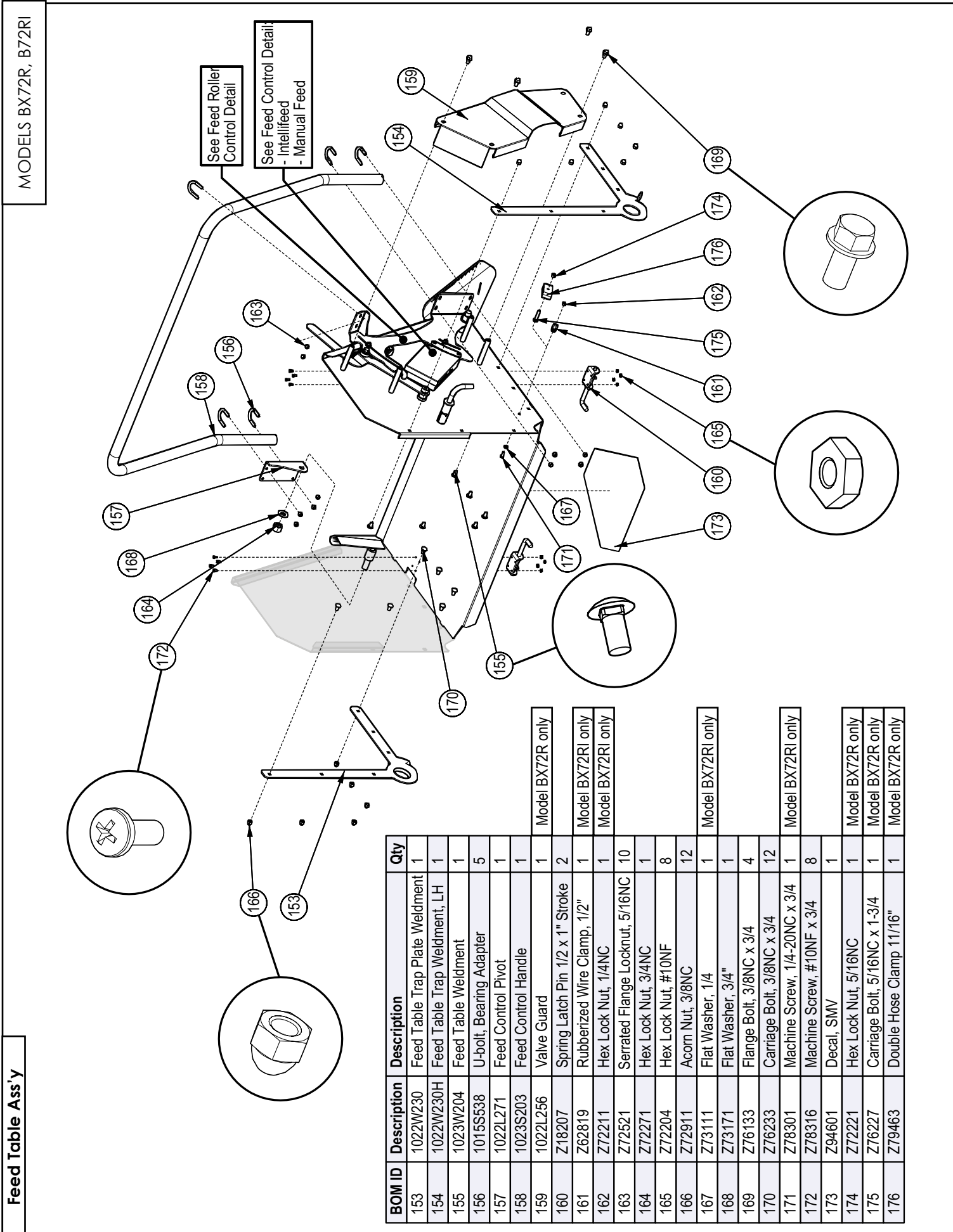

MODELS BX72R, B72RI

Feed Table Ass'y

BOM ID	Description	Description	Qty
153	1022W230	Feed Table Trap Plate Weldment	1
154	1022W230H	Feed Table Trap Weldment, LH	1
155	1023W204	Feed Table Weldment	1
156	1015SS538	U-bolt, Bearing Adapter	5
157	1022L271	Feed Control Pivot	1
158	1023S203	Feed Control Handle	1
159	1022L256	Valve Guard	1
160	Z18207	Spring Latch Pin 1/2 x 1" Stroke	2
161	Z62819	Rubberized Wire Clamp, 1/2"	1
162	Z72211	Hex Lock Nut, 1/4NC	1
163	Z72521	Serrated Flange Locknut, 5/16NC	10
164	Z72271	Hex Lock Nut, 3/4NC	1
165	Z72204	Hex Lock Nut, #10NF	8
166	Z72911	Acorn Nut, 3/8NC	12
167	Z73111	Flat Washer, 1/4	1
168	Z73171	Flat Washer, 3/4"	1
169	Z76133	Flange Bolt, 3/8NC x 3/4	4
170	Z76233	Carriage Bolt, 3/8NC x 3/4	12
171	Z78301	Machine Screw, 1/4-20NC x 3/4	1
172	Z78316	Machine Screw, #10NF x 3/4	8
173	Z94601	Decal, SMV	1
174	Z72221	Hex Lock Nut, 5/16NC	1
175	Z76227	Carriage Bolt, 5/16NC x 1-3/4	1
176	Z79463	Double Hose Clamp 11/16"	1

**Manual Feed Roller Control Detail**

MODEL BX72R

BOM ID	Description	Description	Qty
155	Z56215	Spring Ctr Low Force Directional Valve	1
156	1022M213	Bearing Yoke	1
157	1022M217	Solid Bearing	1
158	Z11301	Clevis Pin 3/16 x 1-3/8"	1
159	Z12210	Hitch Pin Clip, 1/16	1
160	Z51122	Nipple, MP x MP 0808	1
161	Z51451	#8JIC x 1/2NPT 90 Elbow	4
162	Z51487	Tee MJIC x MP x MJIC 080808	1
163	Z56305	Brand PFC 0-8 GPM	1

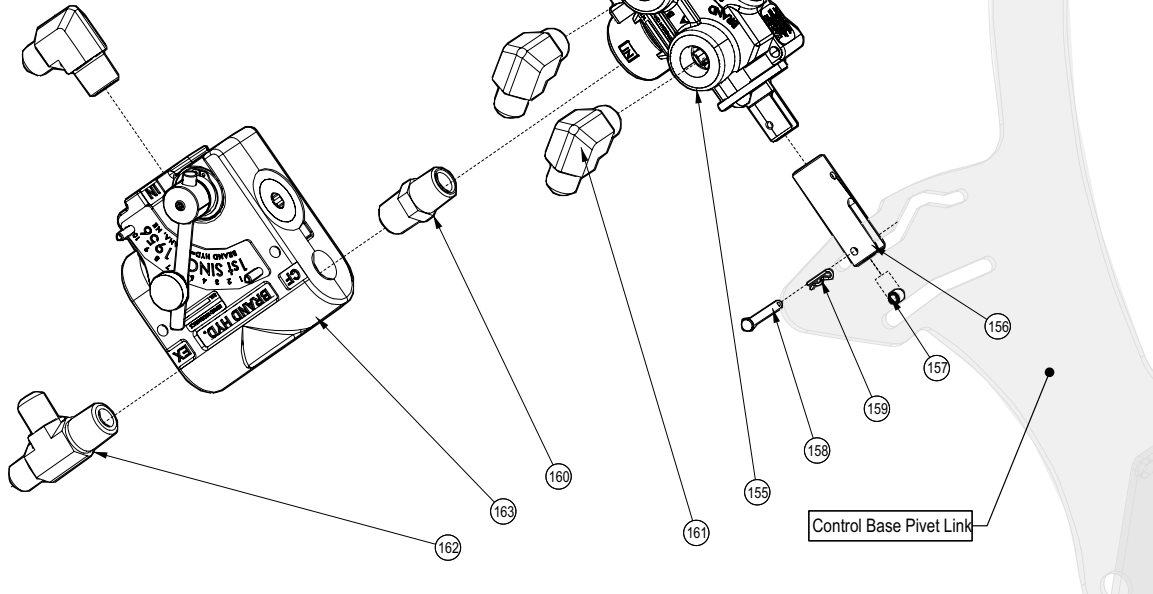

**Feed Roller Control Detail**

MODELS BX72R, B72RI

BOM ID	Description	Description	Qty
164	1015M537	Bushing, Bearing	2
165	1022L239	Control Base Pivot Link	1
166	1022W224	Detent Reset Weldment	1
167	Z21203	Ball Bearing 6202 RS	1
168	Z31401	Spring 3/4 x 4" Heavy	1
169	Z71420	Hex Bolt, 7/16NC x 2	1
170	Z72211	Hex Lock Nut, 1/4NC	2
171	Z72221	Hex Lock Nut, 5/16NC	1
172	Z72241	Hex Lock Nut, 7/16NC	1
173	Z72271	Hex Lock Nut, 3/4NC	1
174	Z73122	Flat Washer, 5/16	2
175	Z73171	Flat Washer, 3/4"	1
176	Z73222	PTFE Flat Washer, 5/16 x 0.080"	4
177	Z75522	Shoulder Bolt, 5/16 x 1/2"	2
178	Z75574	Shoulder Bolt, 3/4 x 1	1
179	Z76522	Eye Bolt 5/16NC x 2	1

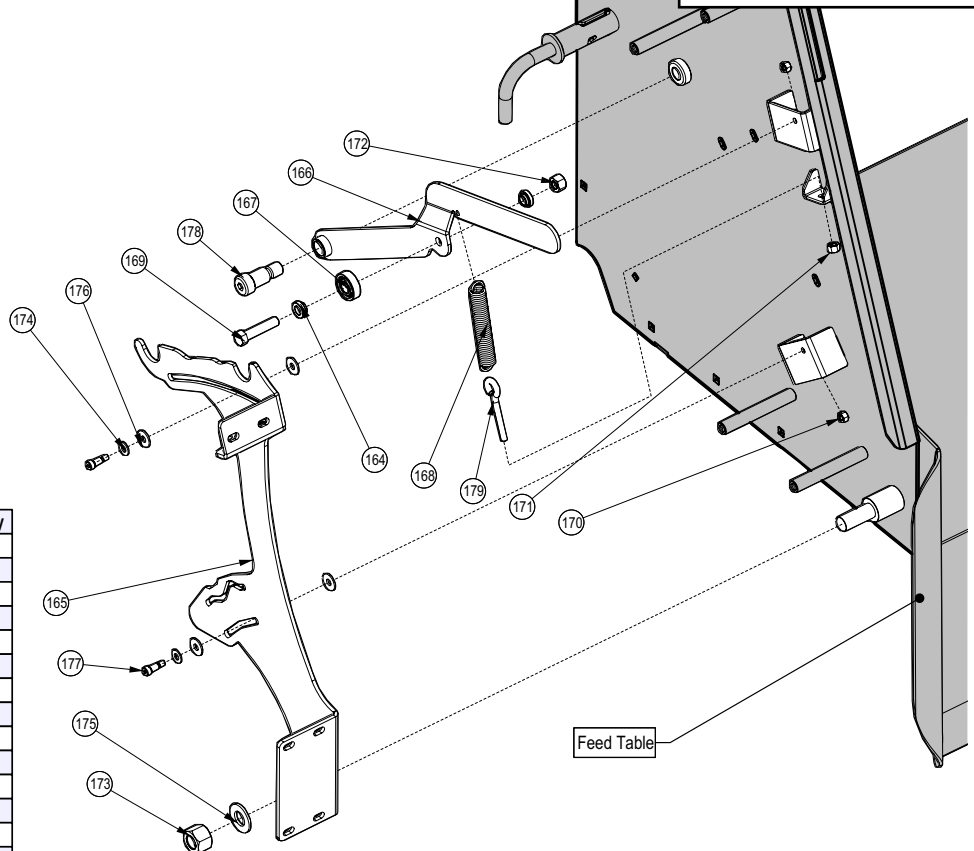

**Intellifeed Roller Control Detail**

MODEL B72RI

BOM ID	Description	Description	Qty
296	1083L154	Switch Mount Plate, BX102RI	1
297	1083L155	Sensor Box Lid	1
298	1083L156	Feed Switch Guard	1
299	1083L157	Feed Pickup Trigger	1
302	Z62823	Rubber Grommet 3/4 x 1/8	2
303	Z64403	Prox Switch NO Sourcing 5amp	1
304	Z64405	Prox Switch NO Sinking 5amp	1
306	Z72211	Hex Lock Nut, 1/4NC	4
307	Z72221	Hex Lock Nut, 5/16NC	4
310	Z72954	Riv-Nut #10-32NF - 130	4
311	Z73111	Flat Washer, 1/4	2
313	Z73123	Rubber Flat Washer, 5/16 x 0.093"	3
318	Z76133	Flange Bolt, 3/8NC x 3/4	4
319	Z76221	Carriage Bolt, 5/16NC x 3/4	3
321	Z77282	Jam Nut, M14 x 1.5	4
322	Z78301	Machine Screw, 1/4-20NC x 3/4	2
323	Z78303	Machine Screw, #10-32NF x 1/2	4

**Intellifeed Components**

MODEL B72RI

BOM ID	Description	Description	Qty
177	1083W151	BX102R IntellIFEED Weldment	1
178	1023L751	Rotor Speed Indicator, BX102R	1
179	1023L752	Sensor Mounting Bracket	1
180	Z46315	Shaft Collar, 1-3/8" ID x 9/16	1
181	Z51492	Elbow 90 MJIC x BH 0808	1
182	Z51493	BH Locknut, 08	1
183	Z51641	#6ORB x #6JIC	2
184	Z51643	#8ORB x #8JIC	1
185	Z51673	Tee, MJIC x MORB x MJIC 080808	1
186	Z56508	CR IntellIFEED Manifold 6gpm	1
187	Z62816	Deutsch Mounting Clip	1
188	Z62819	Rubberized Wire Clamp, 1/2"	1
189	Z62822	Rubber Grommet 3/4 x 1/4	1
190	Z66204	Control, IntellIFEED	1
191	Z66210	IntellIFEED Pickup Sensor with 68" Lead	1
192	Z71235	Hex Bolt, 5/16NC x 3-1/2	2
193	Z72211	Hex Lock Nut, 1/4NC	1
194	Z72357	Brass Jam Nut, 9/16-18NF	2
195	Z72531	Flange Nut 3/8NC	1
196	Z72956	Riv-Nut 5/16NC x 150	2
197	Z72958	Riv-Nut 3/8NC x 150	2
198	Z76133	Flange Bolt, 3/8NC x 3/4	3
199	Z78301	Machine Screw, 1/4-20NC x 3/4	1
200	Z78303	Machine Screw, #10-32NF x 1/2	4

PTO Shaft #Z44504

MODELS BX72R, B72RI

**Binacchi SPARE PARTS LIST : B5D056US098001**

POS.	DESCRIPTION	Q.	Part #
01	YOKE	1	08005003
02	GROSS JOURNAL ASS.	2	08205
05	OUTER TUBE YOKE	1	08005021
08	FLEXIBLE PIN	1	098701075
12	CM. 100 CARDAN TUBE(*)	1	09881523100
13	CM. 100 CARDAN TUBE(*)	1	09881454100
16	FLEXIBLE PIN	1	0987001065
17	INNER TUBE YOKE	1	08005011
21	SHEAR BOLT M10X1.5X55	1	Z19407 (5 Pack)
25	CONE SHIELD BELL 05-06	2	021906C001
26	OUTER BEARING 05	1	025505C001
27	OUTER BASE CONE 05-06	1	025406C001
28	SCREW	6	0998052242
29	OUTER SAFETY TUBE	1	0988981NB5056
30	INNER SAFETY TUBE	1	0988975NB5056
31	INNER BASE CONE 05-06	1	025406C002
32	INNER BEARING 05	1	025505C002
40	CHAIN	1	0252000001
48	LABEL DANGER OUTER DRIVE TUBE	1	09872006
49	EXTERNAL SHIELD LABEL	1	09872003
51	COMPLETE PUSH BUTTTON	1	0986014047
71	YOKE FOR LB5	1	08896905
72	GREASE NIPPLE	1	0984010150
73	STEEL BALL	23	098680104
74	HUB	1	088965A60
75	PUSH PIN SET	1	0986014075
76	NUT AND BOLT M10 x 1.5 x 55 10.9	1	Z19407 (5 Pack)
93	OUTER HALF SHAFT	1	B5056US2
94	INNER HALF SHAFT	1	B5056US1098001
97	SAFETY GUARD	1	0833US05056

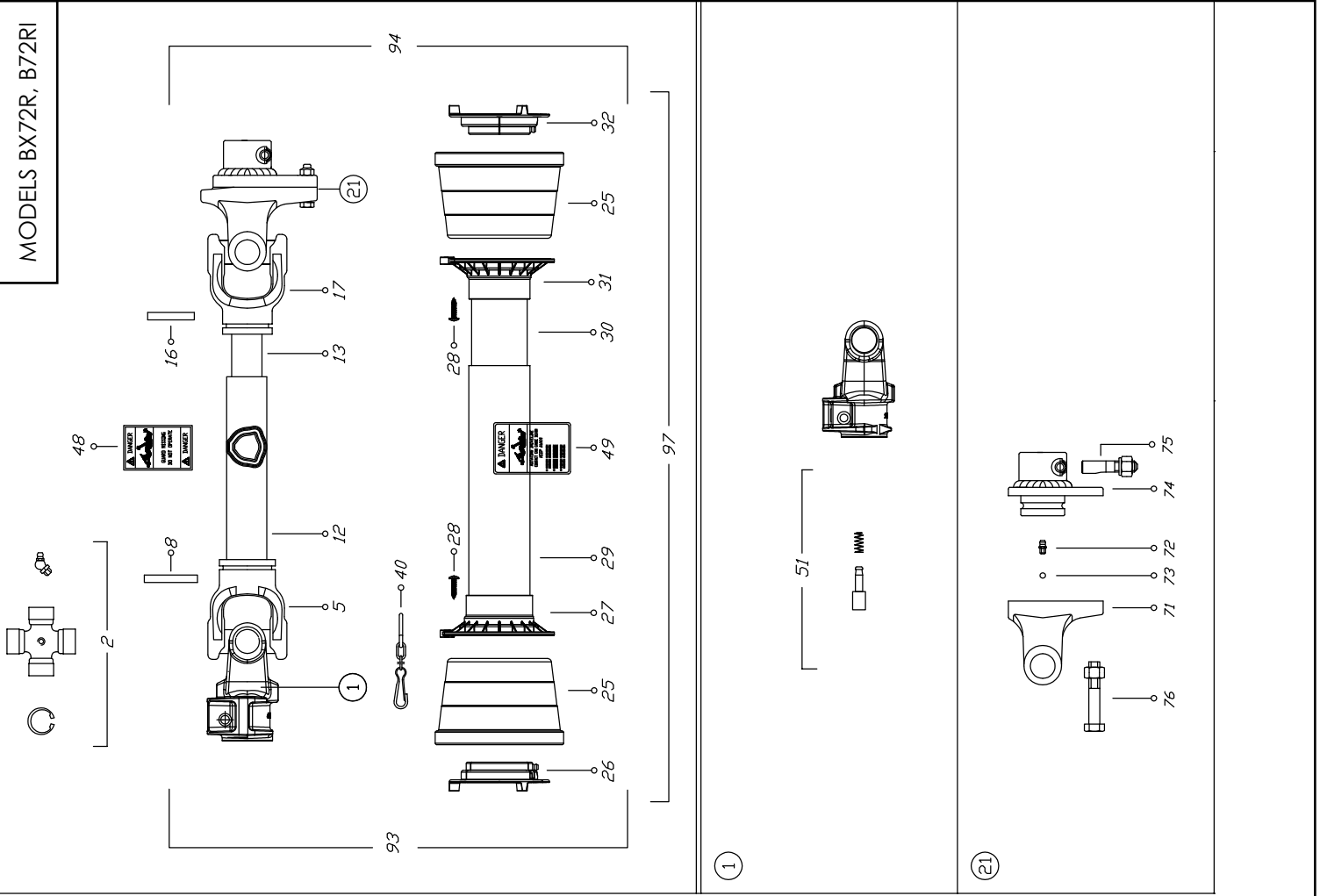



## Intellifeed Settings

**Programming Hints:** The factory settings provide good overall performance for the BX chippers, however you may under certain circumstances, choose to customize performance. Here are some helpful hints:

- For heavier brush, decrease the upper flow percentage for slower feed speed.
- For lighter brush, increase the upper flow percentage for faster feed speed.
- If the chipper is stalling before the feed rolls stop, increase the rotor floor setting.
- If you prefer more aggressive feeding with faster feed and more stops, increase the lower flow percentage.

### 1. Programming Upper RPM Limit (Ceiling):

- **factory setting is :**
  - **500 RPM for 540 RPM operating speed**
  - **950 RPM for 1000 RPM operating speed**
- Press mode button twice. Digital readout will display current upper limit setting. This represents the RPM at which the Rapid Recovery Auto Reverse will re-start the feed rolls after a suspension.
- Oil Use indicator will flash. Increase or decrease setting using program buttons

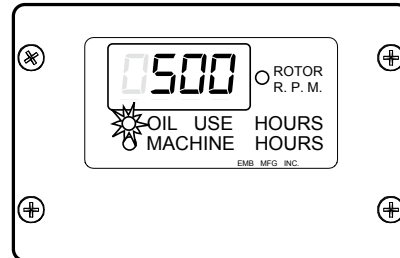

### 2. Programming Upper Flow Percentage:

- **factory setting is 65%**
- Press mode button once more. Digital readout will display current upper flow setting. This represents the percent of hydraulic flow that will be sent to the feed rolls (Feed speed.).
- Oil Use indicator will flash. Increase or decrease setting using program buttons, do not set above 80 %

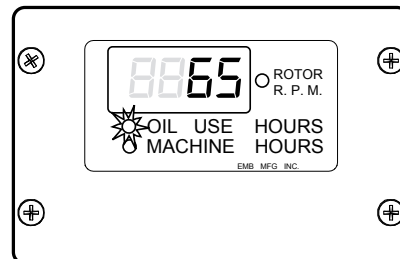

### 3. Programming Lower RPM Limit (Floor) :

- **Factory setting is:**
  - **300 RPM for 540 RPM operating speed**
  - **650 RPM for 1000 RPM operating speed**
- Press mode button once more. Digital readout will display current lower limit setting. This represents the rotor RPM at which the Rapid Recovery Auto Reverse will reverse and suspend the feed rolls.
- Machine hours indicator will flash. Increase or decrease setting using program buttons.

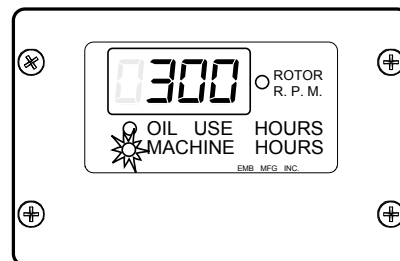

### 4. Programming Lower Flow Percentage:

- **factory setting is 35%**
- Press mode button once more. Digital readout will display current lower flow setting. This represents the percent of hydraulic flow that will be sent to the feed rolls (Feed speed.).
- Machine hours indicator will flash. Increase or decrease setting using program buttons, do not set below 25%

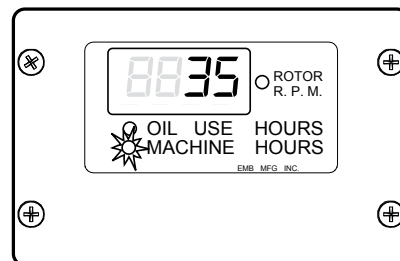

MODELS BX72R, B72RI

Intellifeed Wiring Diagram #Z62109

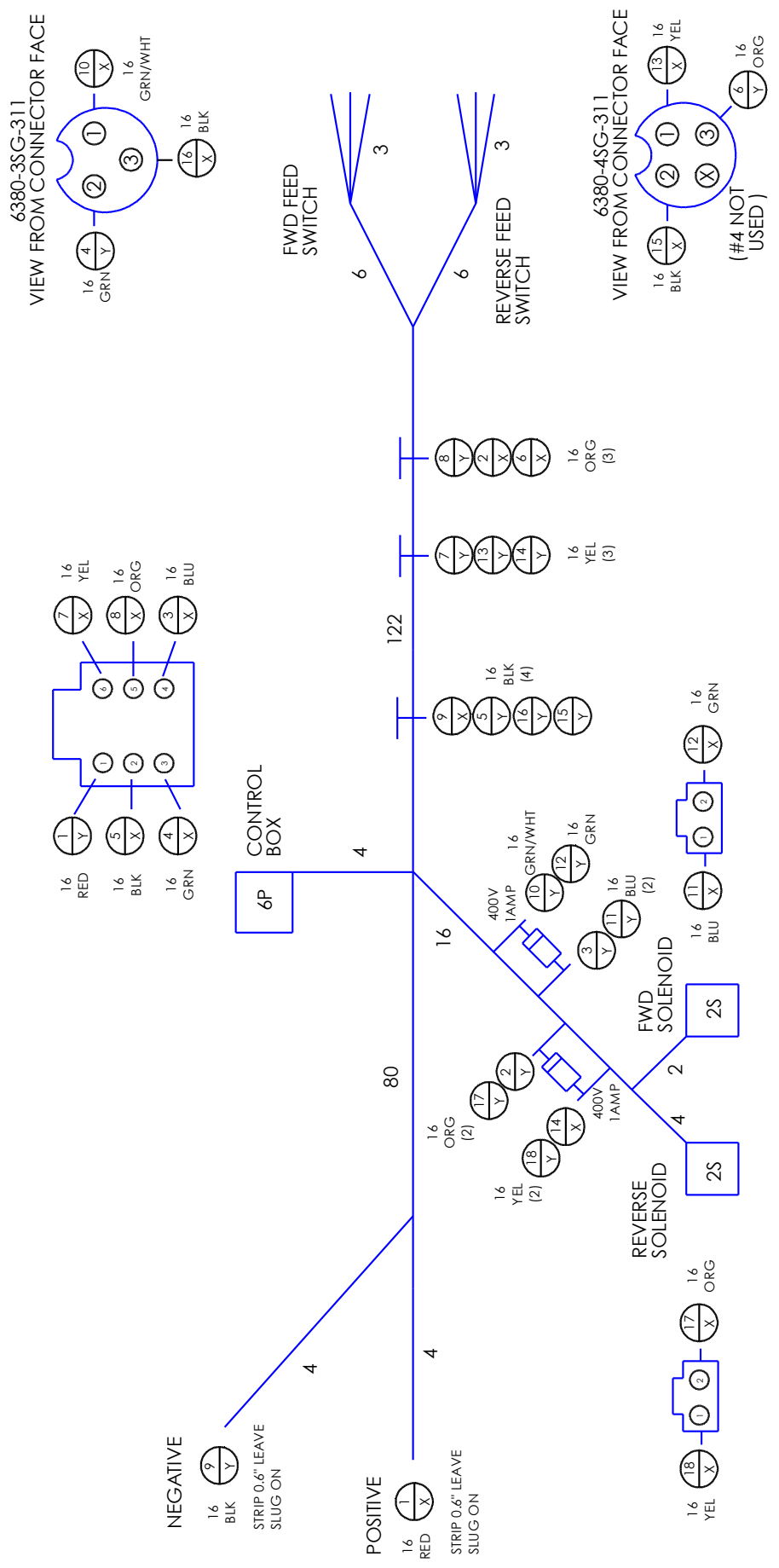

**Hydraulic Hose Parts List**

The Chart below is a complete list of hydraulic hoses for all models of the BX72. For information on your model and its hose connections please review the hydraulic schematics on the following pages.

PARTNUMBER		Description	QTY.
With Protective Sleeve	With Out Protective Sleeve		
n/a	Z52126	1/4 Hose, FJIC04 x 90FJIC04 x 34"	1
n/a	Z52127	1/4 Hose, FJIC04 x 90FJIC04 x 26"	1
Z52250SC	Z52250	3/8 Hose, FJIC08 x 90FJIC08 x 23"	2
Z52255SC	Z52255	3/8 Hose, FJIC08 x 90FJIC06 x 106"	2
Z52280SC	Z52280	1/8 Hose, FJIC08 x FJIC08 x 70"	2
Z52281SC	Z52281	3/8 Hose, FJIC08 x FJIC08 x 68"	1
Z52308SC	Z52308	1/2 Hose, MP08 x FJIC08 x 54"	2
Z52343SC	Z52343	1/2 Hose, FJIC08 x FJIC08 x 22"	1
Z52345SC	Z52345	1/2 Hose, FJIC08 x 90FJIC08 x 16"	1
Z52352SC	Z52352	1/2 Hose, FJIC 08 x FJIC08 x 82"	2

**Hoses with Protective Sleeves are required for EU models**

Hydraulic Schematic BX72R

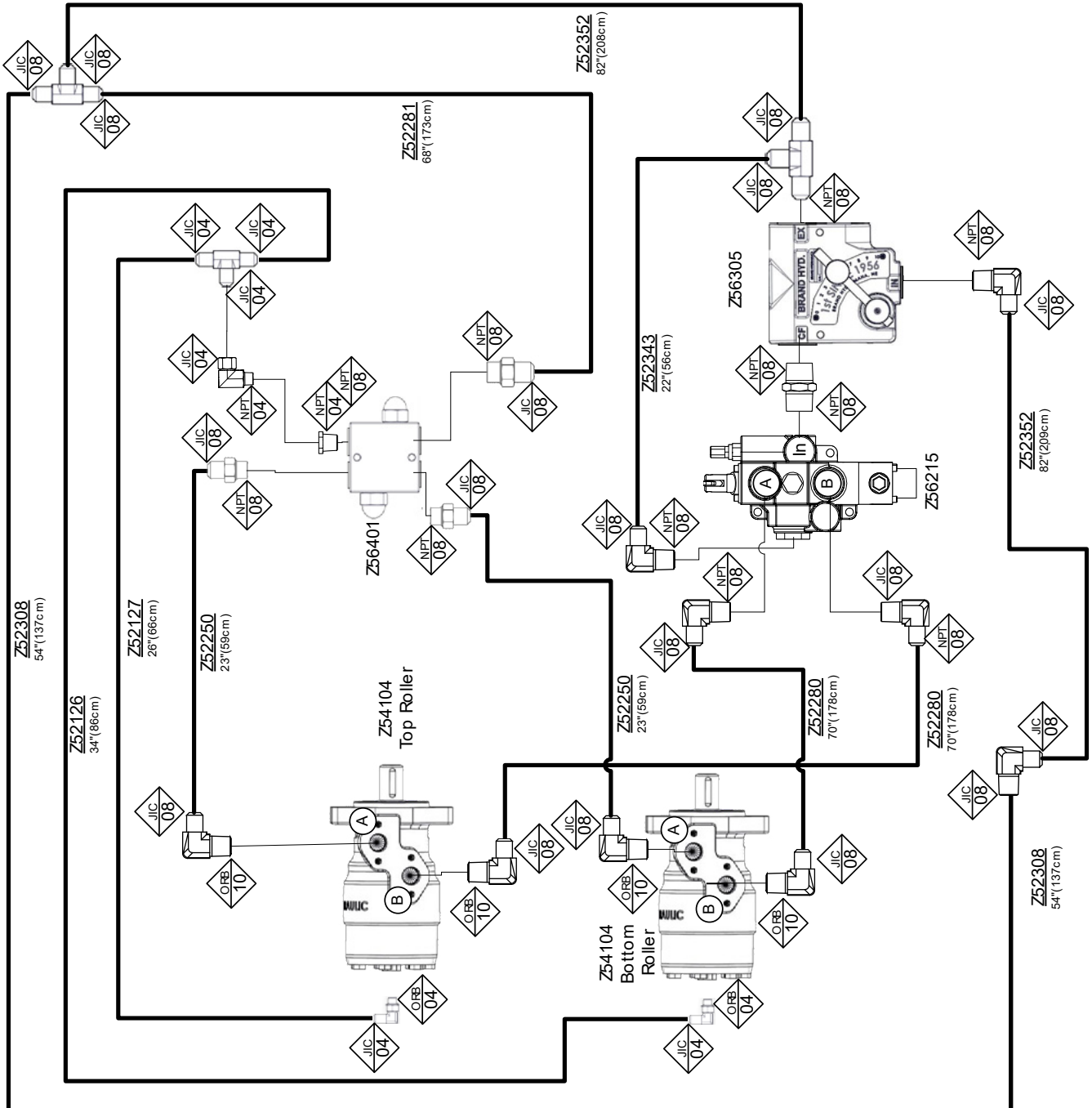

Fitting Identification
Connection Type NPT - National Pipe Thread JIC - Tube Flare ORB - "O" Ring Boss HB - Hose Barb
Connection Type NPT 12
Connection Size

EU models require hydraulic hoses with sleeve covers: see Hydraulic Hose Parts List page

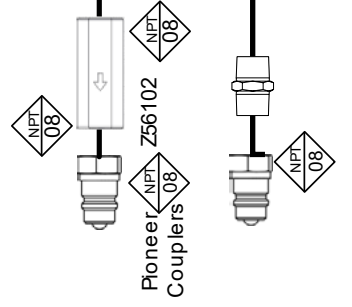

**Hydraulic Schematic BX72RI**

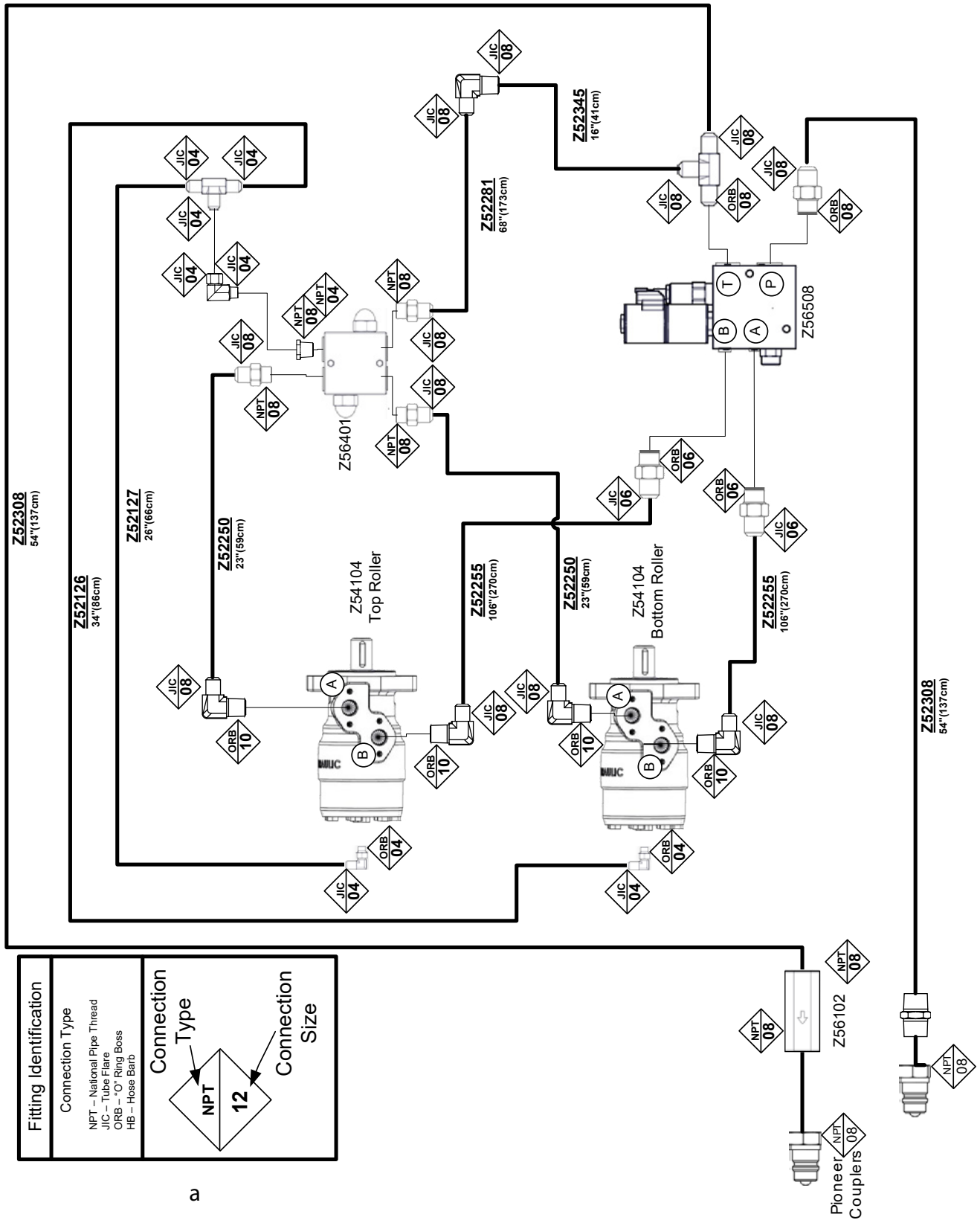

REMEMBER - If safety signs have been damaged, removed, become illegible or parts replaced without safety signs, new signs must be applied. New safety signs are available from your authorized dealer.

Labels - Left Side View

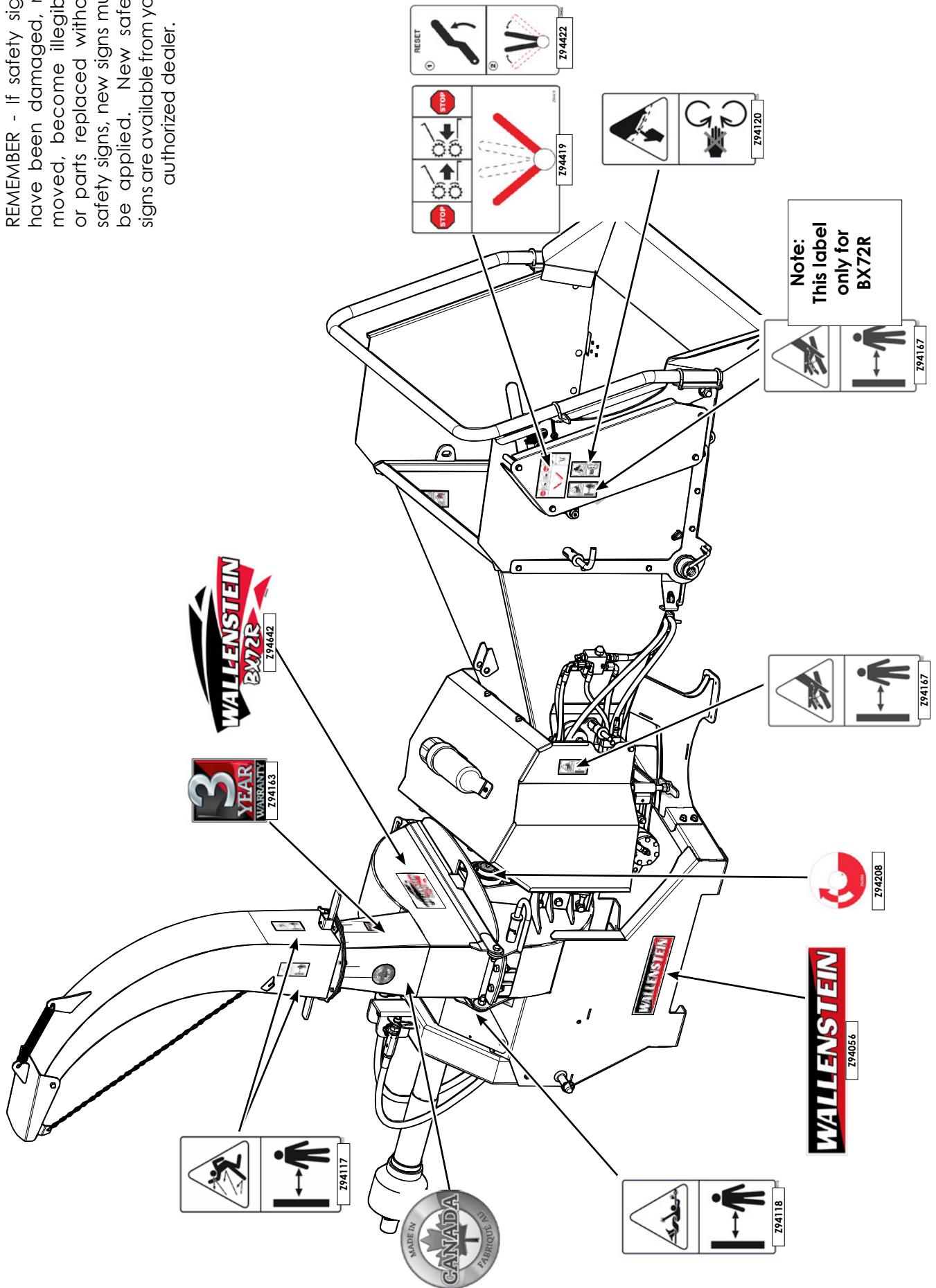

Labels - Right Side View

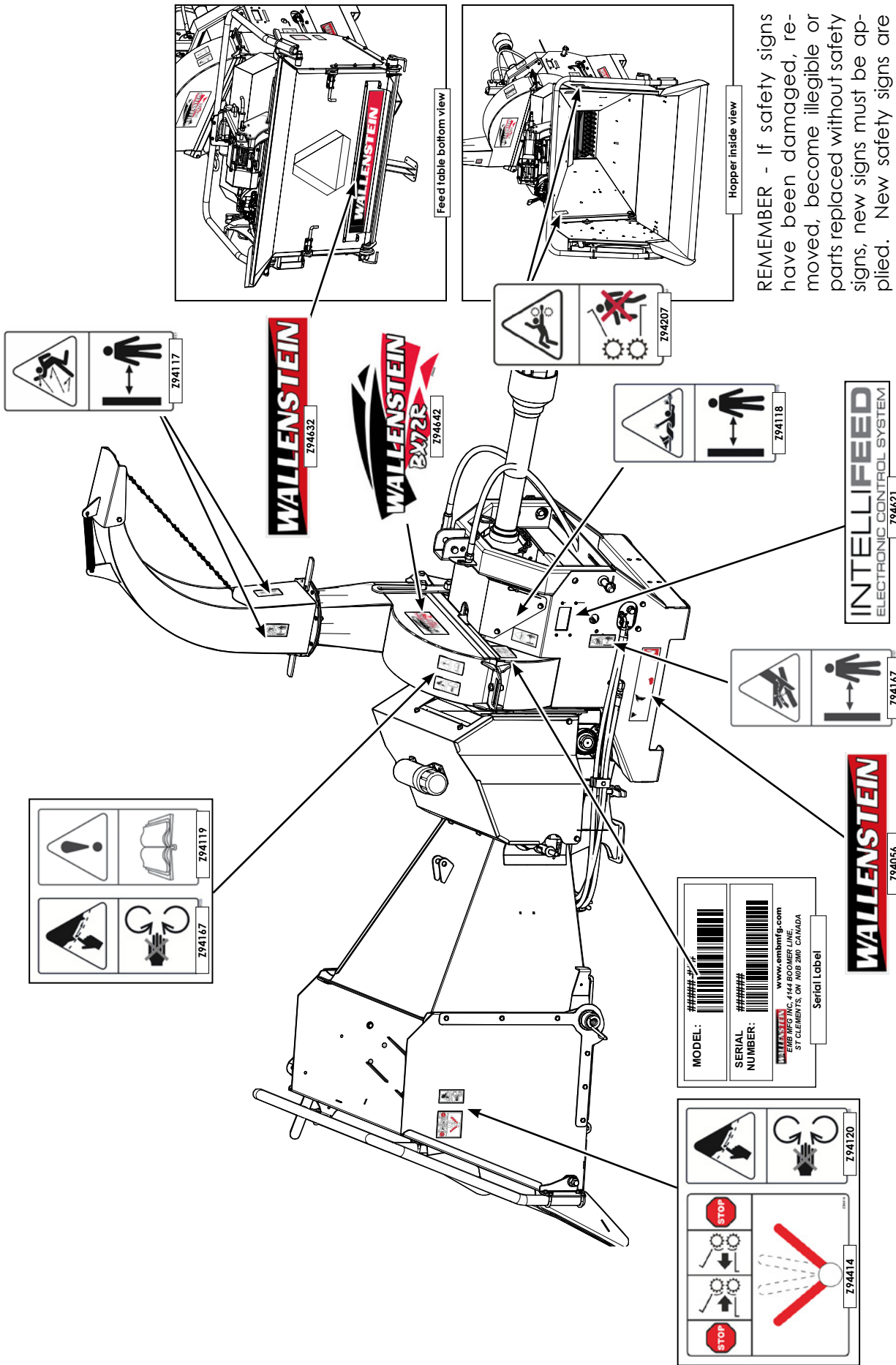

REMEMBER - If safety signs have been damaged, removed, become illegible or parts replaced without safety signs, new signs must be applied. New safety signs are available from your authorized dealer.

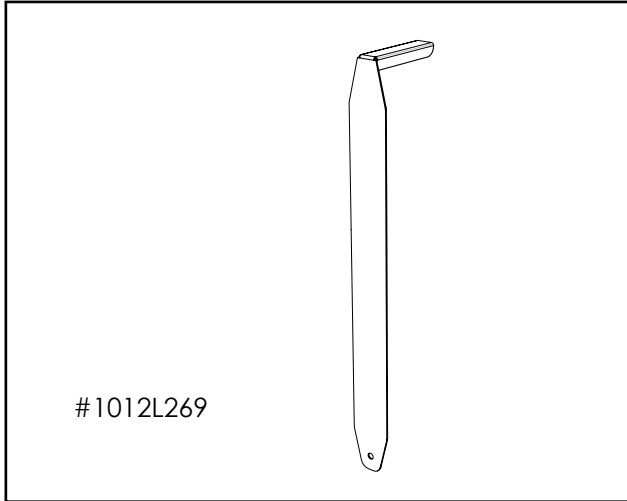

#1012L269

**#1012L269 LEDGER CLEARANCE SETTING GAUGE**

For **BX72 Series**

An easy and accurate way of setting the critical clearances between the ledger blade and the rotor chipper blade.

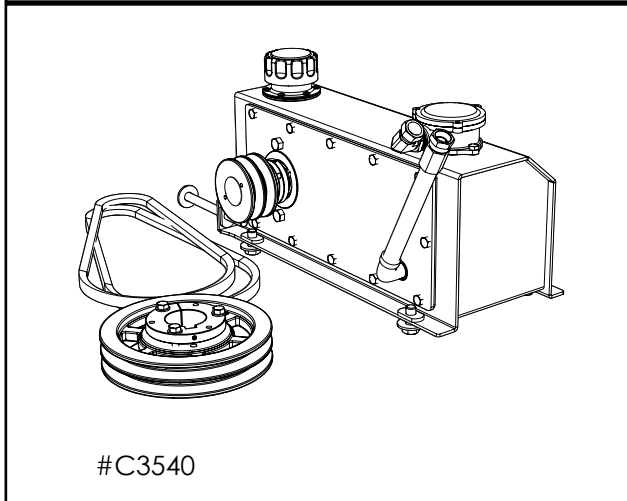

#C3540

**#C3540 SELF CONTAINED PTO POWER PACK**

For model: **BX72 Series**

Easy to install

For tractors without available hydraulics, the optional power-pack mounts on the chipper just under the PTO shaft, and provides you with the means to operate the hydraulic feed hopper on model BX72R.

**Manual**

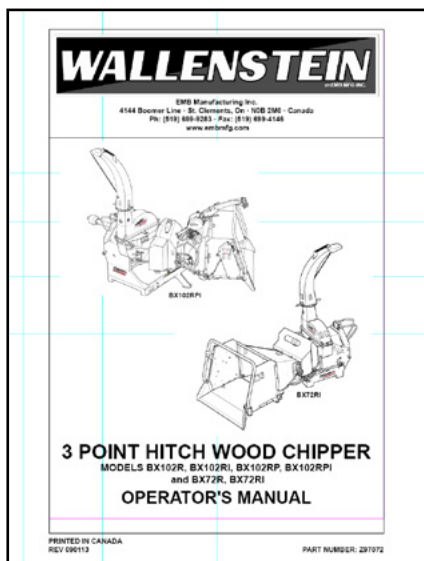

**Z97072**

Available as a download at [www.embmfg.com](http://www.embmfg.com)