

# OPERATOR'S MANUAL

---

## WXR545PL TRAILER WOOD SPLITTER

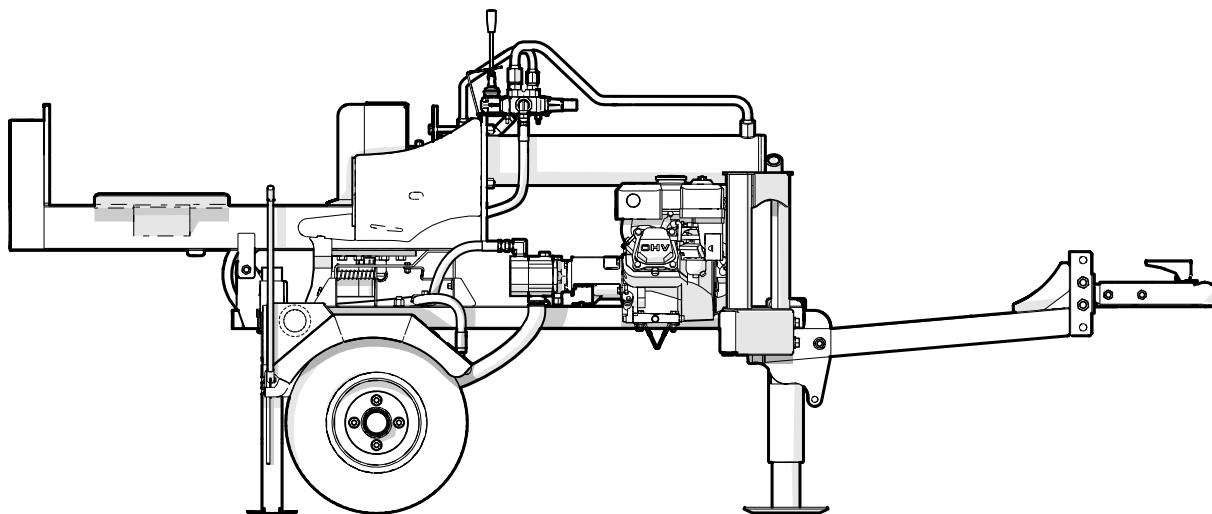

# 1. Introduction

## 1.1 Foreword

Congratulations on choosing a **Wallenstein Trailer Wood Splitter!**

This high-quality machine is designed and manufactured to meet the needs of an efficient wood splitting operation.

The 22-ton WXR Series wood splitters feature Wallenstein *2x2-Speed Firebolt* Technology. Splitting cycle time is reduced using a high-volume, two-stage hydraulic pump and a regenerative control valve. The valve provides two cylinder extend speeds that provide either high speed or high power.

This manual covers the WXR545PL trailer wood splitter. The WXR545PL features horizontal, 20° angled, and vertical splitting.

Keep this manual handy for reference and to pass on to new operators or owners. Call your Wallenstein dealer, distributor or the factory if you need assistance, information or additional copies of the manuals.

**Review all safety, operation and maintenance information contained in this manual.**



### **WARNING!**

**Do not attempt to start or operate the machine without thoroughly reviewing this manual for safe and proper operation.**

**Keep this manual with the machine at all times.**

W034

## Table of Contents

<b>1. Introduction.....</b>	<b>2</b>	<b>7. Transporting.....</b>	<b>30</b>
1.1 Foreword .....	2	7.1 Prepare for Transport .....	30
1.2 Delivery Inspection Report .....	4	7.2 Connecting a Tow Vehicle.....	31
1.3 Serial Number Location .....	5	<b>8. Storing the Wood Splitter .....</b>	<b>31</b>
1.4 Warranty .....	6	8.1 Removing from Storage.....	31
1.5 Decal Information .....	7	<b>9. Service and Maintenance.....</b>	<b>32</b>
<b>2. Safety.....</b>	<b>8</b>	9.1 Fluids and Lubricants .....	32
2.1 Safety Alert Symbol .....	8	9.2 Maintenance Schedule .....	32
2.2 Signal Words .....	8	9.3 Grease Points.....	33
2.3 Why is SAFETY important?.....	9	9.4 Hydraulic Oil – Changing.....	34
2.4 Safety Rules .....	9	9.5 Hydraulic Oil Filter – Changing.....	34
2.5 Equipment Safety Guidelines .....	10	9.6 Engine Air Cleaner .....	35
2.6 Safety Training .....	10	9.7 Electrical System – General .....	35
2.7 Be Prepared .....	10	<b>10. Troubleshooting.....</b>	<b>36</b>
2.8 Operating Safety.....	11	<b>11. Specifications.....</b>	<b>37</b>
2.9 Transport Safety .....	11	11.1 Machine Specifications.....	37
2.10 Refueling Safety .....	12	11.2 Common Bolt Torque Values .....	38
2.11 Tire Safety .....	12	11.3 Hydraulic Fitting Torque .....	39
2.12 Hydraulic Safety .....	12	11.4 Wheel Lug Torque.....	39
2.13 Gas Engine Safety.....	13	<b>12. Alphabetical Index.....</b>	<b>40</b>
2.14 Maintenance Safety.....	14		
2.15 Sign-Off Form.....	15		
<b>3. Safety Signs .....</b>	<b>16</b>		
3.1 Safety Sign Locations.....	16		
3.2 Safety Sign Explanations.....	17		
3.3 Replacing Damaged Safety Signs.....	17		
<b>4. Familiarization.....</b>	<b>18</b>		
4.1 To the New Operator .....	18		
4.2 Machine Components.....	19		
<b>5. Controls .....</b>	<b>20</b>		
5.1 Engine Controls .....	20		
5.2 Hydraulic Controls .....	21		
5.3 Tilting Splitter Bed .....	22		
<b>6. Splitter Operation .....</b>	<b>22</b>		
6.1 Before Starting the Engine .....	22		
6.2 Pre-operation Checklist .....	23		
6.3 Machine Break-In .....	23		
6.4 Engine Oil Level Check .....	24		
6.5 Hydraulic Oil Level Check .....	24		
6.6 Fuel Level Check.....	25		
6.7 Engine Air Cleaner .....	25		
6.8 Machine Set-up .....	26		
6.9 Starting the Engine .....	27		
6.10 Stopping Procedure.....	28		
6.11 Stopping in an Emergency .....	28		
6.12 Log Placement.....	28		
6.13 Operating Hints.....	29		

## 1.2 Delivery Inspection Report

### WALLENSTEIN WXR545PL Trailer Wood Splitter

**To activate warranty, register your product online at  
<http://www.wallensteinequipment.com>**

Customer's Name \_\_\_\_\_

Contact Name \_\_\_\_\_

Dealer Name \_\_\_\_\_

(\_\_\_\_\_) \_\_\_\_\_  
Phone Number

Serial Number \_\_\_\_\_

\_\_\_\_\_/\_\_\_\_\_/\_\_\_\_\_  
Delivery Date

I have thoroughly instructed the buyer on the equipment care, adjustments, safe operation and applicable warranty policy and reviewed the manual.

Dealer's Rep. Signature \_\_\_\_\_

\_\_\_\_\_/\_\_\_\_\_/\_\_\_\_\_  
Date

The product manuals have been received by me and I have been thoroughly instructed as to care, adjustments, safe operation and applicable warranty policy.

Owner's Signature \_\_\_\_\_

\_\_\_\_\_/\_\_\_\_\_/\_\_\_\_\_  
Date

<input checked="" type="checkbox"/>	<b>Pre-delivery Inspection</b>
Inspect for damage from shipping. Immediately contact the shipping company if damage is found.	
<b>Trailer Wood Splitter</b>	
	Hydraulic Valve Control Function
	Hydraulic Cylinder Function
	Hydraulic Reservoir level
	Engine Oil Level
	Horizontal / Vertical Pivot Moves Freely (as equipped)
	Front and Rear Support Stands Move freely
	All fasteners are Tight
	Lubricate all Pivot Points (as equipped)
	Check that all Hydraulic Connections are tight
	Review Operating and Safety Instructions
<b>Safety Checks</b>	
	All Safety Decals Installed
	Guards and Shields Installed and Secured
	Check Function of Brake and Signal Lighting
	Supports Function Correctly
	Safety Chain on Hitch
	Retainer Installed Through Ball Hitch
	Review Operating and Safety Instructions

### 1.3 Serial Number Location

Always provide the model and serial number of your Wallenstein product when ordering parts, or requesting service or other information. The product information plate location is shown in the illustration.

**For future convenience, record the product Model and Serial Number in the spaces provided below.**

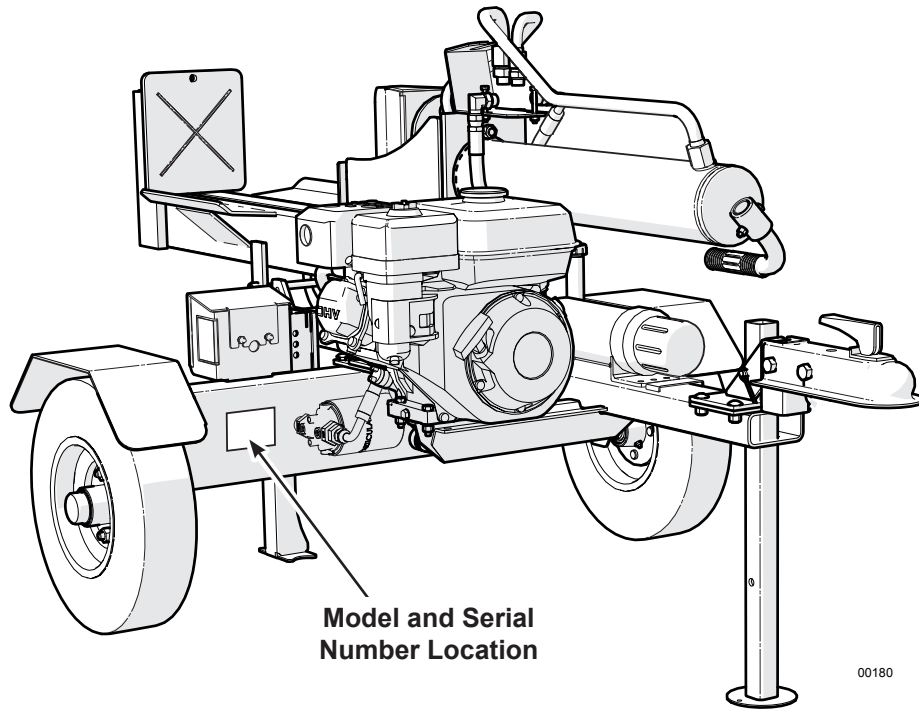

Fig. 1 – Product Information Plate Location (typical for all models)

Record Product Information Here	
Model:	WXR545PL
Serial Number:	

## 1.4 Warranty



### LIMITED WARRANTY

Wallenstein products are warranted to be free of defects in materials and workmanship under normal use and service, for a period of

**Five Years for Consumer Use**

**Two Years for Commercial/Rental Use**

from the date of purchase, when operated and maintained in accordance with the operating and maintenance instructions supplied with the unit. Warranty is limited to the repair of the product and/or replacement of parts.

This warranty is extended only to the original purchaser and is not transferable.

Repairs must be done by an authorized dealer. Products will be returned to the dealer at the customer's expense. Include the original purchase receipt with any claim.

**This warranty does not cover the following:**

- 1) Normal maintenance or adjustments
- 2) Normal replacement of wearable and service parts
- 3) Consequential damage, indirect damage, or loss of profits
- 4) Damages resulting from:
  - Misuse, negligence, accident, theft or fire
  - Use of improper or insufficient fuel, fluids or lubricants
  - Use of parts or aftermarket accessories other than genuine Wallenstein parts
  - Modifications, alteration, tampering or improper repair performed by parties other than an authorized dealer
  - Any device or accessories installed by parties other than an authorized dealer
- 5) Engines. Engines are covered by the manufacturer of the engine for the warranty period they specify. For the details of your engine warranty, see your engine owner's manual. Information about engine warranty and service is also available in the FAQ section at [www.wallensteinequipment.com](http://www.wallensteinequipment.com)

## 1.5 Decal Information

When getting familiar with the Wallenstein product, notice that there are numerous decals located on the machine. There are different types of decals for safety, information, and product identification. The following section explains what they are for and how to read them.

**Safety Decals** are pictorial with a yellow background and generally two panel. The top panel shows the safety alert (the potential hazard) and the bottom panel shows the message (how to avoid the hazard).

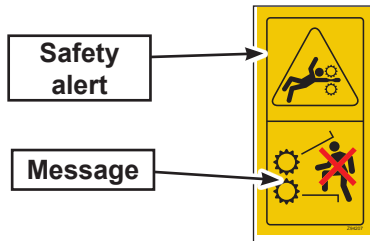

**Safety Notice Decals** are pictorial with a blue background and generally rectangular with single or multiple symbols. This decal informs what Personal Protective Equipment is required for safe operation.



**Informative Decals** are generally pictorial with a white background and can vary in the number of panels. This type of decal explains how a control works or offer operational information.

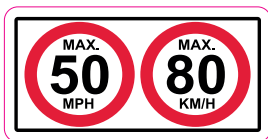

**Product Decals** indicate machine model and serial number, and other important information.

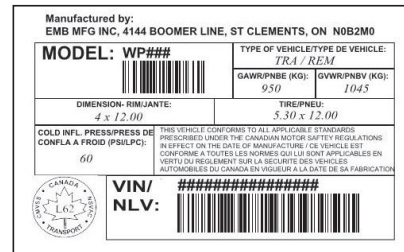

**Maintenance Decals** have a green background and can vary to the number of panels. This decal shows a type maintenance required and frequency interval.



See the section on safety signs for safety decal definitions. For a complete illustration of decals and decal locations, download the parts manual for your model product at [www.wallensteinequipment.com](http://www.wallensteinequipment.com).

## 2. Safety

### 2.1 Safety Alert Symbol

This Safety Alert Symbol means:

**ATTENTION! BE ALERT!**

**YOUR SAFETY IS INVOLVED!**

The **Safety Alert Symbol** identifies important safety messages on the Wallenstein wood splitter and in the manual. When you see this symbol, be alert to the possibility of personal injury or death. Follow the instructions in the safety message.



### 2.2 Signal Words

The signal words **DANGER**, **WARNING** and **CAUTION** determine the seriousness level of the warning messages in this manual. The appropriate signal word for each message in this manual has been selected using the following guidelines:

#### **DANGER –**

Indicates an imminently hazardous situation that, if not avoided, **will** result in death or serious injury. This signal word is to be limited to the most extreme situations typically for machine components which, for functional purposes, cannot be guarded.

#### **WARNING –**

Indicates a potentially hazardous situation that, if not avoided, **could** result in death or serious injury, and includes hazards that are exposed when guards are removed. It may also be used to alert against unsafe practices.

#### **CAUTION –**

Indicates a potentially hazardous situation that, if not avoided, **may** result in minor or moderate injury. It may also be used to alert against unsafe practices.

**IMPORTANT** – To avoid confusing equipment protection with personal safety messages, a signal word **IMPORTANT** indicates a situation that if not avoided, could result in damage to the machine.

 **NOTE:** *(plus text) – indicates an additional explanation for an element of information.*



## 2.3 Why is SAFETY important?

### Three Big Reasons:

- **Accidents Disable and Kill**
- **Accidents Cost**
- **Accidents Can Be Avoided**

The policy of EMB Manufacturing Inc. is to produce products that are safe and reliable. However, even when using well-engineered equipment, there is always an element of risk. To minimize the risks and promote safety at all times, this section of the operator's manual details a number of safety rules that must always be followed and obeyed.

**YOU** are responsible for the SAFE operation and maintenance of your Wallenstein Trailer Wood Splitter. **YOU** must ensure that you and anyone else who is going to use, maintain or work around the wood splitter be familiar with the operating and maintenance procedures and related safety information contained in this manual. This manual provides good safety practices that should be followed while using the wood splitter.

Remember, **YOU** are the key to safety. Good safety practices not only protect you but also the people around you. Make these practices a working part of your safety program. Be certain that **EVERYONE** using this equipment is familiar with the recommended use and maintenance procedures and follows all the safety precautions.

## 2.4 Safety Rules

- **DO** give operating instructions to operators or employees before allowing them to operate the machine, and REVIEW annually thereafter.
- **DO** read and understand ALL Safety and Operating instructions in the manual and follow them. The most important safety device on this equipment is a SAFE operator. 
- **DO** review safety related items annually with all personnel who are operating the machine or performing maintenance.

- **DO** wear appropriate Personal Protective Equipment (PPE). The suggested equipment includes but is not limited to the following:
  - Hearing Protection
  - Protective glasses, goggles or face shield
  - Heavy work gloves
  - Protective shoes with slip resistant soles

- **DO** have a first-aid kit available for use should the need arise and know how to use it.



- **DO** read and understand all safety signs located on the machine before operating, servicing, adjusting, or cleaning.
- **DO** inspect and secure all guards before starting.
- **DO** check engine intake and exhaust. Make sure they are clear of debris prior to starting the machine.
- **DO** inspect and secure all guards before starting.

- **DO** have a fire extinguisher available for use should the need arise. Know how to use it.



- **DO** think SAFETY! Work SAFELY!
- **DO NOT** touch hot engine parts, muffler cover, hydraulic hoses, engine body, engine oil, and so on during operation or if the engine was recently shut off. Contact may cause burns.
- **DO NOT** expect a person who has not read and understood all operation and safety instructions to use the machine. An untrained operator is not qualified and is exposed to possible serious injury or death. It is the owner's responsibility to make sure to the operator has familiarity and understanding of the machine.
- **DO NOT** allow riders during transport.
- **DO NOT** risk injury or death by ignoring good safety practices.

## 2.5 Equipment Safety Guidelines

Always place the machine in a **Safe Condition** before performing any service work, maintenance procedures, or storage preparation.

### **SAFE CONDITION**

- Shut off engine.
- Make sure all moving parts have stopped.
- Disconnect battery ground (-) cable.
- Block or chock wheels.

1. Never use equipment with safety shields removed. Keep all shields in place. If shield removal becomes necessary for repairs, reinstall the shield prior to use.
2. Replace any safety sign or instruction sign that is not readable or is missing. Location of safety signs is indicated in this manual.
3. Do not allow anyone other than a responsible, properly trained and physically able person to operate this machine. This equipment is dangerous to children and persons unfamiliar with its operation.
4. Do not modify the equipment in any way. Unauthorized modification may result in serious injury or death and may impair the function and life of the equipment.
5. Never exceed the limits of the machine. If its ability to do the job or to do it safely is in question—**STOP IMMEDIATELY!**

## 2.6 Safety Training

1. The best safety feature is an informed, careful operator—we ask you be that kind of operator. It is the operator's responsibility to read, understand and follow ALL safety and operation instructions in the manual.



2. Train all new personnel and review instructions frequently with existing workers. Only properly trained and physically able operators should use this equipment. **A person who has not read and understood all operation and safety instructions is not qualified to use the machine.** Untrained operators expose themselves and bystanders to possible serious injury or death. If elderly people are assisting with the work, their physical limitations need to be recognized and accommodated.

3. Learn the controls and how to stop the machine quickly in an emergency.
4. If this machine is loaned or rented, it is the machine owner's responsibility to make certain that every operator:
  - Reads and understands the owner's manual
  - Is instructed in safe and proper use of the equipment
  - Understands and knows how to perform the Safe Condition procedure

## 2.7 Be Prepared

1. Determine where the split wood is going to be piled ahead of time. Make sure it does not interfere with safe loading of wood into the splitter.
2. Pre-cut logs so wood is ready to load into the splitter. Do not run a chainsaw and the splitter at the same time.
3. Determine a safe work area location:
  - Area must be clear of stones, branches or hidden obstacles that might cause a tripping, hooking or snagging hazard.
  - Ground should be firm and level.
4. Operate only in daylight or good artificial light.
5. Make sure machine is properly adjusted and in good operating condition.
6. Store fuel well away from the wood pile.
7. Perform the **Pre-operation Checklist** procedure before starting work (see *Pre-operation Checklist on page 34*).
8. Do not operate on hillsides or when working area is cluttered, wet, muddy or icy to prevent slipping and tripping. Operate only on level ground.
9. Position machine so prevailing winds blow engine exhaust fumes away from operator's station.
10. Do not operate machine inside a closed building to prevent asphyxiation from engine exhaust.
11. Stop engine when leaving the machine unattended.

## 2.8 Operating Safety

Read and obey the safety signs on the machine. Clean or replace them if they are not legible.

There is no substitute for a cautious, safe-minded operator who recognizes potential hazards and follows reasonable safety practices. This machine must be used with all its safety equipment properly installed to minimize the chance of accidents.

1. Wear appropriate personal protective equipment. Tie back long hair, remove jewelry, and avoid loose fitting clothing. Prolonged exposure to loud noise can cause permanent hearing loss! Wear hearing protection on a full-time basis when using this machine.
2. The operator must be in control of the machine at all times. Read and understand owner's manual before starting. Review safety instructions annually.
3. Never use engine-powered machinery indoors. Gas engine exhaust contains toxic carbon monoxide, which cannot be smelled or seen. Breathing carbon monoxide can be lethal.
4. Make sure all guards, deflectors and shields are in place before starting and operating.
5. Keep hands out of splitting area. Do not rest hands on the log being split.
6. Do not step over or straddle splitter during operation.
7. Do not try to split more than one log at a time. The logs can fly out and cause injury.
8. Keep your fingers and hands away from cracks in the log that can open while splitting.
9. Always load logs by grasping the bark side, not the cut ends.
10. Do not reach into or load the splitter when the wedge is in motion.
11. Do not try to split logs across the grain. Some types of wood can burst or splinter causing pieces to be thrown causing injury.
12. For uneven cut logs, always place the squares cut end against the splitting wedge.
13. Never place any part of your body where it would be in danger if machine movement should occur during assembly, installation, operation, maintenance, repairing or moving.
14. Before servicing or repairing the machine, place it in a **Safe Condition**. See *page 10*.

## 2.9 Transport Safety

1. Comply with local laws governing safety and transporting of machinery on public roads.
2. Do not exceed 50 mph (80 km/h) when towing this machine. Slow down for rough terrain and cornering.
3. Do not transport or move the wood splitter with the engine running.
4. Be sure the trailer is hitched correctly to the towing vehicle and a retainer is used through the hitch mechanism.
5. Always attach safety chains between the hitch and the towing vehicle. Cross the chains underneath the trailer tongue.
6. Check wheel lugs and tighten if required. Inspect rims for damage.
7. Inspect tires for cuts or damage. Check tire pressure and adjust if required.
8. Ensure the stability jacks are raised and secured with the latch pin.
9. Make sure tow vehicle is fitted with the correct size (2 in) towing ball.
10. Make sure fuel and hydraulic tank caps are on tight to prevent spills while transporting.
11. Clean all debris off the splitter. Remove any tools or other loose items.
12. Check that all the lights, reflectors and other lighting requirements are installed and in good working condition.
13. Never allow riders on the machine.
14. Be a safe and courteous driver. Always yield to oncoming traffic in all situations, including narrow bridges, intersections, and so on.
15. Watch for other traffic when near or crossing roadways.
16. Do not drink and drive.
17. Before transporting, perform a walk-around inspection to ensure everything is safe.

## 2.10 Refueling Safety

1. Engine fuel is highly flammable. Handle with care.
2. Fill fuel tank outdoors.
3. Stop the engine before refueling. Allow engine to cool for five minutes. Clean up spilled fuel before restarting engine.
4. Do not overfill the fuel tank.
5. If fuel is spilled, wipe it away carefully and wait until the fuel has dried before starting the engine.
6. Do not refuel the machine while smoking or when near open flame or sparks.
7. After refueling, make sure that the fuel cap is secured to prevent spillage.
8. Prevent fires by keeping machine clean of accumulated trash, grease, and debris.



## 2.11 Tire Safety

1. Failure to follow proper procedures when mounting a tire on a wheel or rim can produce an explosion which may result in serious injury or death.
2. Do not attempt to mount a tire unless you have the proper equipment and experience to do the job.
3. Have a qualified tire dealer or repair service perform required tire maintenance.
4. When replacing worn tires, make sure they meet the original tire specifications. Never install undersized tires.

## 2.12 Hydraulic Safety

1. Make sure that all the components in the hydraulic system are kept in good condition and are clean.
2. Before applying pressure to the system, make sure all components are tight, and that lines, hoses and couplings are not damaged.
3. Do not attempt any makeshift repairs to the hydraulic lines, fittings or hoses by using tapes, clamps or cements. The hydraulic system operates under extremely high pressure. Such repairs can fail suddenly and create a hazardous and unsafe condition.
4. Wear proper hand and eye protection when searching for a high-pressure hydraulic leak. Use a piece of wood or cardboard as a backstop instead of hands to isolate and identify a leak.
5. If injured by a concentrated high-pressure stream of hydraulic fluid, seek medical attention immediately. Serious infection or toxic reaction can develop from hydraulic fluid piercing the skin surface.
6. Relieve pressure in the hydraulic system before working on it.

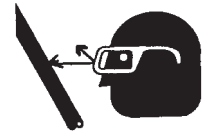

## 2.13 Gas Engine Safety

### CAUTION!

**Before starting engine, review the operating and maintenance instructions in the engine manual.**

W019

1. **DO NOT** operate engine in an enclosed area. Exhaust gases contain odorless and deadly carbon monoxide that can cause death by asphyxiation.
2. **DO NOT** place hands or feet near moving or rotating parts.
3. **DO NOT** store, spill, or use gasoline near an open flame, or devices such as a stove, furnace, or water heater which use a pilot light or devices which can create a spark.
4. **DO NOT** refuel indoors where area is not well ventilated.
5. **DO NOT** refuel while engine is running. Allow engine to cool for five minutes before refueling. Store fuel in approved safety containers.
6. **DO NOT** remove fuel tank cap while engine is running.
7. **DO NOT** operate engine if gasoline is spilled. Move machine away from the spill and avoid engine ignition until gasoline has evaporated.
8. **DO NOT** smoke while filling fuel tank.
9. **DO NOT** choke carburetor to stop engine. Whenever possible, gradually reduce engine speed before stopping.
10. **DO NOT** run engine above rated speeds. This may result in injury.
11. **DO NOT** tamper with governor springs, governor links or other parts which may increase the governed speed.
12. **DO NOT** tamper with the engine as set by the original equipment manufacturer.
13. **DO NOT** check for spark with spark plug or spark plug wire removed.
14. **DO NOT** crank engine with spark plug removed. If engine is flooded, crank until engine starts.
15. **DO NOT** strike flywheel with a hard object or metal tool as this may cause flywheel to shatter in operation. Use proper tools to service engine.
16. **DO NOT** operate engine without a muffler. Inspect periodically and replace, if necessary.
17. **DO NOT** operate engine with an accumulation of grass, leaves, dirt or other combustible materials in the muffler area.
18. **DO NOT** use this engine on any forest covered, brush covered, or grass covered unimproved land unless a spark arrester is installed on the muffler. The arrester must be maintained in effective working order by the operator. In the state of California, the above is required by law (Section 4442 of the California Public Resources Code). Other states may have similar laws. Federal laws apply on federal land.
19. **DO NOT** touch hot muffler, engine body or cooling fins. Contact may cause burns.
20. **DO NOT** run engine with air cleaner or air cleaner cover removed.

### **Be sure to:**

1. Remove the wire from the spark plug when servicing the engine or equipment to prevent accidental starting. Disconnect the (-) ground wire from the battery terminal.
2. Keep engine cooling fins and governor parts free of grass and other debris that can affect engine speed.
3. Examine muffler periodically to be sure it is functioning effectively. A worn or leaking muffler should be repaired or replaced as necessary.
4. Use fresh gasoline. Old fuel can clog carburetor and cause leakage.
5. Check fuel lines and fittings frequently for cracks or leaks. Replace if necessary.

## 2.14 Maintenance Safety

1. Follow good shop practices:

- Keep service area clean and dry.
- Be sure electrical outlets and tools are properly grounded.
- Use adequate light for the job at hand.



2. Never operate the machine or the towing vehicle in a closed building. The exhaust fumes may cause asphyxiation.
3. Before servicing or repairing, place the machine in a **Safe Condition**. See *page 10*.
4. Allow the engine to cool before performing maintenance. Engine components and oil may be hot enough to cause injury.
5. Never work under equipment unless it is properly supported.
6. When performing any service or maintenance work always use personal protective equipment.
7. Where replacement parts are necessary, use only OEM parts to restore your equipment to original specifications. The manufacturer is not responsible for injuries or damages caused by use of unapproved parts or accessories.
8. Inspect and tighten all bolts, nuts and screws. Check that all electrical and fuel connections are properly secured.
9. When completing a maintenance or service function, make sure all safety shields and devices are installed before placing splitter in service.
10. When cleaning any parts, do not use gasoline. Use a cleanser designed for that purpose.
11. Always use proper tools in good condition. Make sure you understand how to use them, before performing any service work.

## 2.15 Sign-Off Form

Wallenstein follows the general Safety Standards specified by the American Society of Agricultural and Biological Engineers (ASABE). Anyone who is using or maintaining the wood splitter must read and clearly understand ALL Safety, Usage and Maintenance information presented in this manual.

Do not use or allow anyone else to use this wood splitter until such information has been reviewed. Annually review this information before the season start-up.

Make these periodic reviews of SAFETY and OPERATION a standard practice for all of your

equipment. We feel that an untrained operator is unqualified to use this machine.

A sign-off sheet is provided for your record keeping to show that all personnel working with the equipment have read and understand the information in the Operator's Manual and have been instructed in the proper operation of the equipment.

Safety

Sign-off Form		
Date	Owner	Employee

### 3. Safety Signs

#### 3.1 Safety Sign Locations

The types of safety signs and locations on the equipment are shown in the illustrations that follow. Good safety requires that you familiarize yourself with the various safety signs, the type of warning and the area, or particular function related to that area, that requires your SAFETY AWARENESS.

**Think SAFETY! Work SAFELY!**

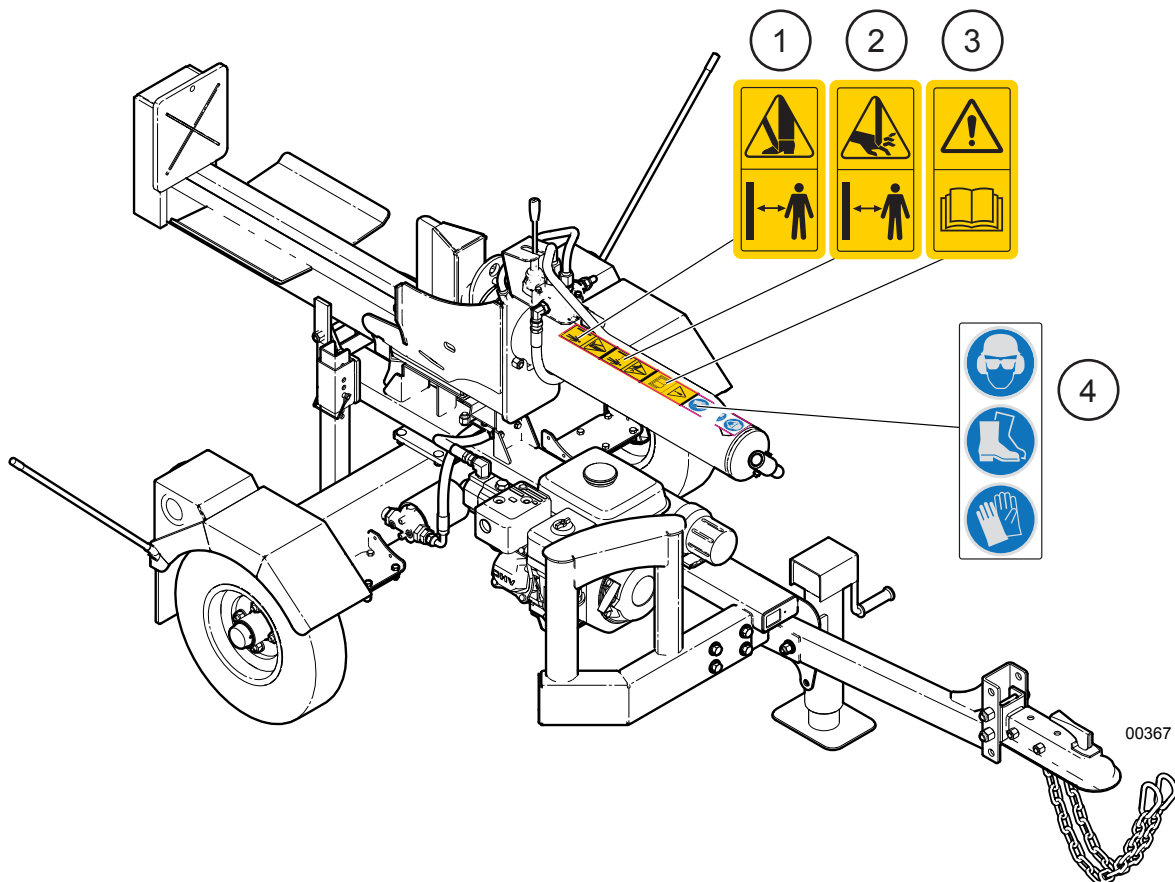

Fig. 2–Safety Sign Locations



## 3.2 Safety Sign Explanations

### 1. Caution



Keep feet away from falling split wood. Always wear steel toed foot wear while machine is operating to avoid serious personal injury.

### 2. Caution



Pinch point / crushing danger! Keep your hands away from all moving parts during and after split operation! Never try to clear a jammed log with your hands! Wait for all moving parts to come to a complete stop before loading or clearing obstructions.

### 3. Caution



Refer to the operator's manual. Read and understand ALL safety and operating instructions. Read and understand ALL safety labels located on the machine.

### 4. Caution



Personal Protective Equipment (PPE) is required when operating this machine. Failure to wear PPE can result in personal injury

## 3.3 Replacing Damaged Safety Signs

1. Keep safety signs clean and legible at all times.
2. Replace safety signs that are missing or have become illegible.
3. Parts that were replaced with a safety decal on them must also have the safety sign replaced.
4. Replacement safety signs are available from your authorized Distributor or Dealer Parts Department or the factory.

### 3.3.1 How to Install Safety Signs

Ambient temperature must be above 50 °F (10 °C) to install decals.

1. Clean and dry the installation area.
2. Determine exact position before removing the backing paper.
3. Peel back the corner of the backing paper.
4. Align the sign over the specified area and carefully press the small portion with the exposed sticky backing in place.
5. Slowly peel back the remaining paper and carefully smooth the remaining portion of the sign in place.
6. Small air pockets can be pierced with a pin and smoothed out using the piece of sign backing paper.

---

## 4. Familiarization

### 4.1 To the New Operator

**It is the responsibility of the owner or operator to read this manual and to train all other operators before they start working with the machine. Follow all safety instructions exactly.**

**By following recommended procedures, a safe working environment is provided for the operator, bystanders and the area around the work site. Untrained operators are not qualified to use the machine.**

Many features incorporated into this machine are the result of suggestions made by customers like you. Read this manual carefully to learn how to use the machine safely and provide maximum operating efficiency. By following the instructions in conjunction with a good maintenance program, your wood splitter can provide many years of trouble-free service.

---

**IMPORTANT! Make sure all operators understand how to put the wood splitter in a Safe Condition before working with this machine. See Safe Condition page 10.**

---

#### 4.1.1 Training

Each operator must be trained in the proper set-up and operating procedures before using the machine.

1. Move the unit to a large open area to allow the operator to become familiar with control functions and machine response.
2. Do not allow untrained operators to use the machine. They can endanger themselves and others, or damage property and the machine.

#### 4.1.2 Job Site Familiarization

It is the responsibility of the operator to be thoroughly familiar with the work site prior to starting.

1. Check for close or cramped work space. Be sure there is sufficient space and clearance for the machine to operate.
2. Organize the working area to minimize movement.
3. Position the machine so prevailing winds blow engine exhaust fumes away from operator's station.

## 4.2 Machine Components

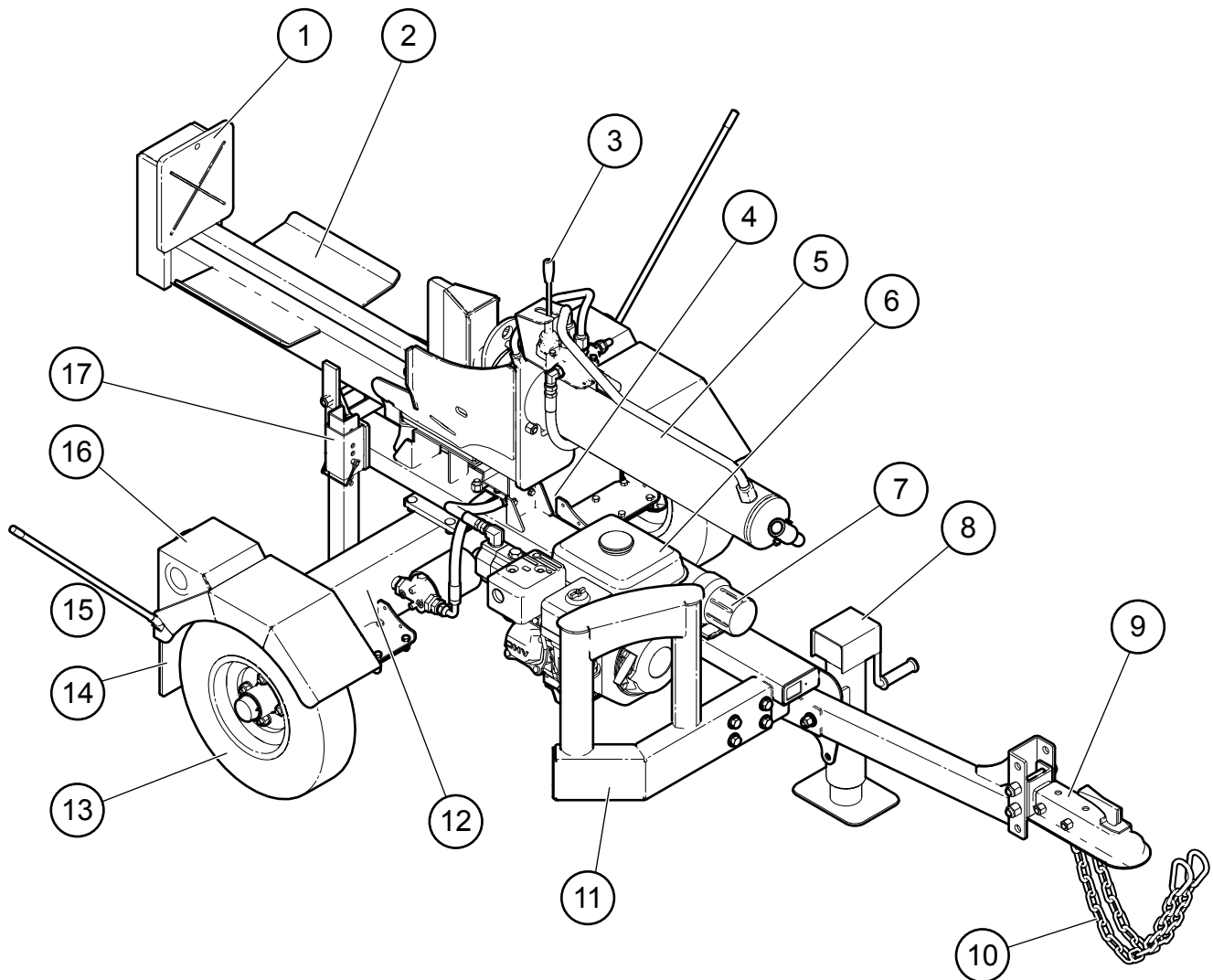

Fig. 3—WXR545PL Wood Splitter Components

1. Tilting Splitter Bed
2. Sliding Wedge
3. Splitter Control Handle
4. Splitter Bed Spring Latch
5. Hydraulic Cylinder
6. Honda GX200 Engine
7. Product Manual Storage Tube
8. Crank Jack Stand
9. Trailer Tongue
10. Safety Chains
11. Engine Guard
12. Hydraulic Oil Reservoir
13. 4.80-8 LRB SportTrail Tire
14. Mud Flaps
15. Width Guides
16. Stop, Tail, Turn Signal Lights
17. Rear Jack Stand

## 5. Controls

**IMPORTANT!** Before starting work with the wood splitter, become familiar with the location and function of all controls.

### 5.1 Engine Controls

Refer to the engine manual that came with this product for further explanation on engine controls.

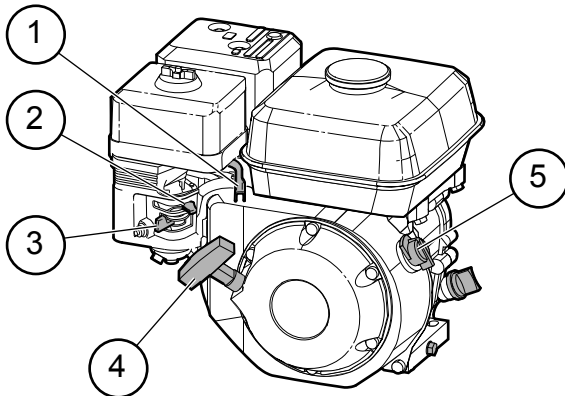

00189

Fig. 4—Engine Controls

1. Throttle Lever
2. Ignition Switch
3. Oil Level Check
4. Oil drain Plug
5. Starting Rope
6. Fuel Valve Lever
7. Choke Lever

#### 5.1.1 Ignition Switch

This rotary switch controls the ignition system.

- The engine operates in the ON position. Before starting the engine, turn the switch to ON.
- Turn it counter-clockwise to OFF to stop the engine.

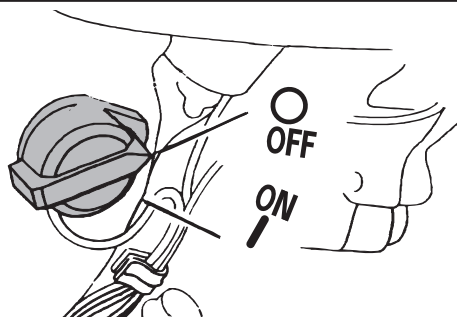

00187

Fig. 5—Ignition Switch

#### 5.1.2 Choke Lever

The choke lever opens and closes the choke valve in the carburetor.

- Place the choke lever in the CLOSED position (3) when starting a cold engine.
- Move the choke lever to the OPEN position (2) after the engine starts. When restarting a warm engine, leave the lever in the OPEN position.

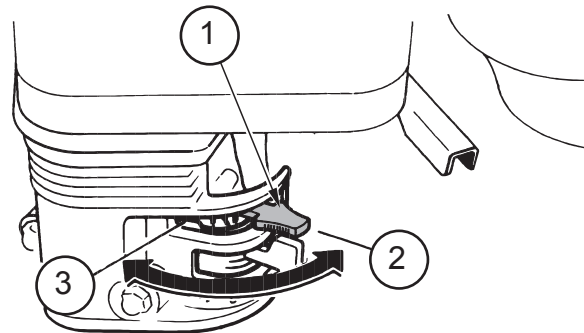

00188

Fig. 6—Choke Lever

1. Choke Lever
2. Choke Open Position
3. Choke Closed Position

#### 5.1.3 Fuel Shut-off Valve

The engine is equipped with a valve between the fuel tank and the carburetor.

- Slide the fuel valve lever toward the block (2) to turn fuel ON, and away (3) to turn OFF.
- Turn the fuel OFF when not in use or when transporting.

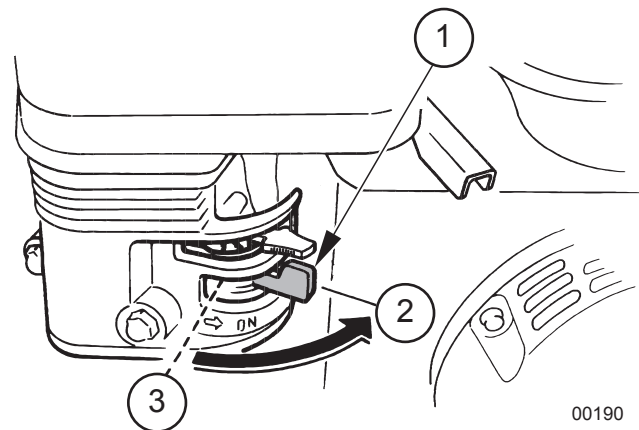

00190

Fig. 7—Fuel Valve Lever

1. Fuel Shut-off Valve Lever
2. ON Position
3. OFF Position

### 5.1.4 Throttle Lever

This lever controls the engine speed. Move the lever side to side to increase or decrease engine rpm. Always operate the wood splitter with the throttle lever in the MAX position.

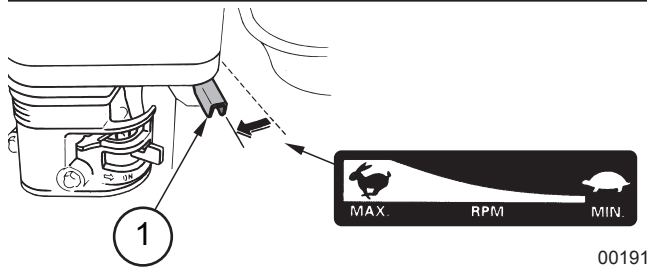
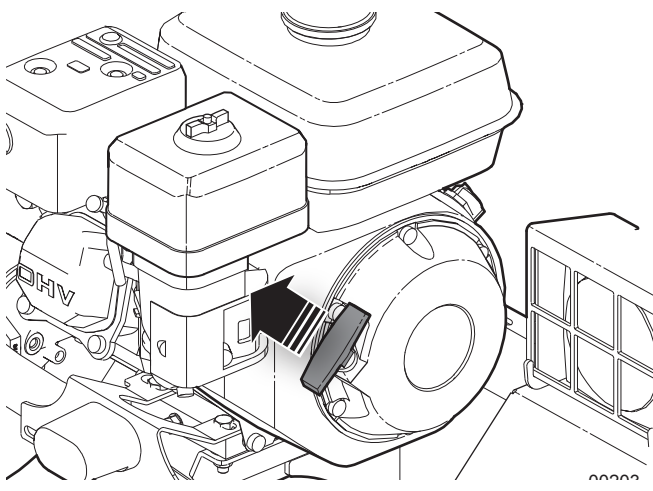

**Fig. 8**–Throttle Lever Positions

1. Throttle Lever

### 5.1.5 Recoil Starter

Pull the starter grip out lightly until resistance is felt, then pull briskly in the direction of the arrow as shown below. Return the starter grip gently.



**Fig. 9**–Recoil Starter

## 5.2 Hydraulic Controls

The WXR Series wood splitters are equipped with **2X2–Speed FIREBOLT** technology. The FIREBOLT system consists of a two-stage hydraulic pump and a regenerative control valve.

Two extend speeds provide either High Speed (2) or High Power (1). High extend speed is achieved by cycling oil from the rod-end of the cylinder through the control valve and reusing it at the base of the cylinder, instead of returning to tank.

When retracting the cylinder, a detent holds the lever until the wedge / push block fully returns, providing hands-free operation.

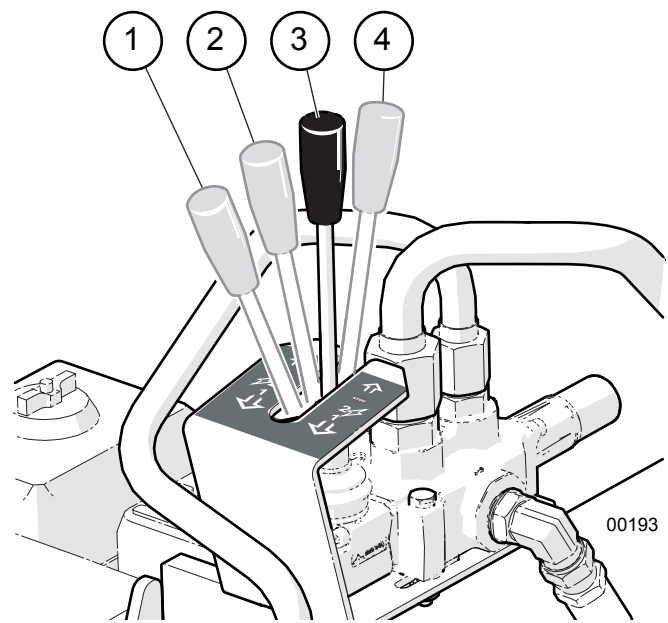

**Fig. 10**–Hydraulic Control Valve Positions

1. High Power
2. High Speed (2)
3. STOP (Neutral)
4. Retract

### 5.2.1 STOP Position

- STOP is the valve's neutral position. The wedge or push block stop moving when the valve lever is moved to this position. The valve lever spring-returns to STOP when released from either extend position, or auto-retract.
- The valve lever can be moved to STOP at any time.

### 5.2.2 High Speed Position (2)

- Pushing the lever forward to High Speed position (2) at the first detent provides a higher cylinder extension speed. In this position the cylinder extends at high speed, but lower power.
- Releasing the lever returns it to STOP.

### 5.2.3 High Power Position (1)

- Push the control lever fully forward to High Power position (1) for maximum power. The cylinder extends at a slower speed but provides higher power to push the wedge or push block through the wood for effective splitting.
- Releasing the lever returns it to STOP.

### 5.2.4 Retract Position

- Pull the lever fully backwards to retract the wedge / push block. The valve detent holds the lever in retract allowing a hands-free return cycle.
- The valve lever returns to STOP (neutral) when wedge / push block is fully retracted.
- The lever can be moved out of Retract into STOP at any time.

## 5.3 Tilting Splitter Bed

The WXR545PL models with the Tilting Splitter Bed have a pivoting main frame that allows the splitter to be used in the horizontal, angled, or vertical positions. Position the splitter bed for the best application.

See *Machine Set-up* on page 26.

## 6. Splitter Operation

Wallenstein WXR Trailer Wood Splitters are self-contained machines designed to push a wedge through the wood to split it. The WXR545PL splitter can be used in the vertical, angled, or horizontal configuration.

**The operator has the responsibility of being familiar with all operating and safety procedures and following them.**

### 6.1 Before Starting the Engine

1. Check the engine oil level. See *page 24*.
2. Check the hydraulic oil level. See *page 24*.
3. Check the fuel level.
4. Check the engine air cleaner. See *page 25*.
5. Review the Safety Rules on *page 9*
6. Clear the area of bystanders, especially small children.
7. Make sure each operator is trained and familiar with the set up and operation of the wood splitter.
8. Follow the Pre-Operation Checklist.
9. Review the Controls (see *page 20*).
10. Survey the work site and place the wood splitter in a clear, level work area.
11. Set up the machine correctly. See *Machine Set-up* on *page 26*.

## 6.2 Pre-operation Checklist

Efficient and safe operation of the Wallenstein wood splitter requires that each operator reads and understands the operating procedures and all related safety precautions outlined in this section.

A Pre-operation Checklist is provided for the operator. The checklist is important for both personal safety and keeping the wood splitter in good mechanical condition.

Before operating the machine and each time thereafter, the following areas should be checked off:

Pre-operation Checklist	✓
Check engine oil level. Top level up as required.	
Check hydraulic fluid level. Top level up as required.	
Check and lubricate the machine following the schedule outlined in the Maintenance section.	
Check the wedge and block. Be sure they are not damaged or broken and is not badly worn. Repair or replace as required.	
Check and remove any entangled material.	
Check for hydraulic leaks. Tighten connections or replace components to stop leaks.	
Check and ensure that all covers, guards and shields are in place, secured, and can function as designed.	
Check and inspect tires, wheels, and hubs.	
Check and tighten all fasteners. Make sure the equipment is in good condition.	
Check that appropriate equipment for personal protection is being used and in good condition.	
Check that jewelry, loose-fitting clothing are not worn. Make sure long hair is tied back.	

## 6.3 Machine Break-In

Although there are no operational restrictions on the wood splitter when used for the first time, it is recommended that the following items be checked:

Review the engine owner's manual for break-in recommendations. Place the machine in a **Safe Condition** before checking any components. To see how to do that, refer to *Safe Condition on page 10*.

### After 1 hour of operation

1. Check that the push block or wedge is adequately lubricated.
2. Check all nuts, bolts and other fasteners. Tighten to their specified torque level.
3. Check hydraulic system for leaks. Tighten all leaking fittings and replace any leaking components.
4. Check machine fluid levels—Fuel, engine oil, and hydraulic oil reservoir. Top up as required.
5. Check for entangled material. Remove all entangled material before resuming work.
6. Check tire pressure. Inflate as required.

### After 8 hours of operation

7. Repeat the above steps.

## 6.4 Engine Oil Level Check

Check engine oil level daily.

Check with the machine parked on level ground and the engine stopped.

**IMPORTANT!** Running the engine with a low oil level can cause engine damage that is not covered by warranty.

1. Remove the oil level dipstick and wipe it clean.
2. Fully insert the oil level dipstick, then remove it to check the oil level. **The proper level is when the oil is visible at the full (upper) mark on the dipstick.**
3. If the oil level is low, add oil until the level is at the full mark.  
**SAE 10W-30 or 5W-30 is recommended for general use.**
4. Reinstall the oil level dipstick.

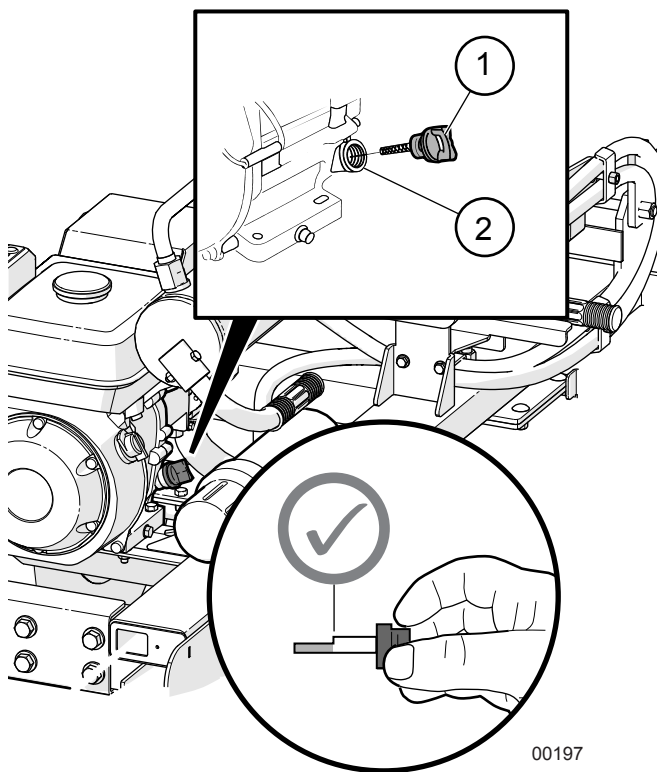

Fig. 11–Engine Oil Level check

1. Oil Level Dipstick
2. Oil Filler
3. Low Level
4. Full Level

Refer to the engine owner's manual included in the manual tube for further information on engine oils.

## 6.5 Hydraulic Oil Level Check

Check hydraulic oil level every 50 hours or weekly.

Check with the machine parked on level ground and the engine stopped.

The proper level is when the oil is visible at the full (upper) mark on the dipstick.

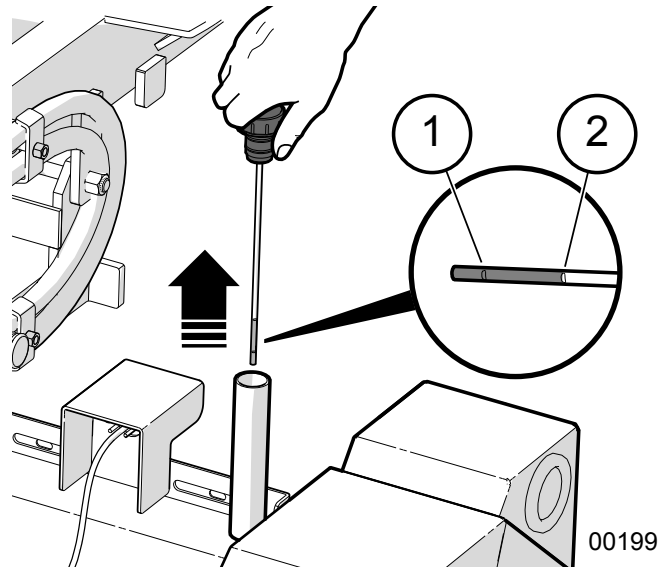

Fig. 12–Hydraulic Tank Oil Level Dipstick

1. Low Level
2. Full Level

**IMPORTANT!** Do not operate machine if oil level is not visible on the dipstick. Damage to the pump and other components can occur.

Do not overfill the tank past the full mark.

**IMPORTANT!** Always check oil levels after changing filters or servicing hydraulic components.

**IMPORTANT!** Hydraulic oil quality should be inspected every 50 hours. If the oil is dirty or smells burnt, it should be replaced.

**IMPORTANT!** Be aware of high oil temperatures. Temperatures higher than 180 °F (82 °C) could cause seal damage and degrade oil quality.



### 6.5.1 Adding Hydraulic Oil to the Tank

The hydraulic system uses **Dexron® III ATF**.

1. Clean the area around filler cap and remove it.
2. Use a clean funnel and add oil until the level is at the full mark on the dipstick.
3. Install filler cap securely. Wipe up any spilled oil.

### 6.6 Fuel Level Check

Check the fuel level daily.

Starting with a full tank helps to eliminate or reduce operating interruptions for refueling.

The fuel tank is located on the engine. Avoid running the tank dry.

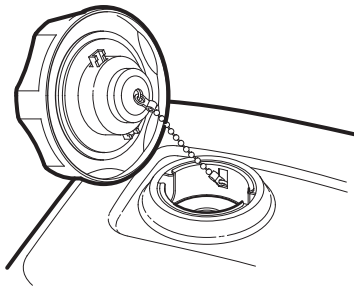

00198

Fig. 13–Fuel Filler Cap

### 6.6.1 Refueling

Fuel tank capacity: **0.82 US gal (3.1 L)**.

#### **WARNING!**



**Fuel vapors can explode causing injury or death. Do not smoke while refueling. Keep sparks, flames, and hot components away.**

Refuel in a well-ventilated area with the engine stopped. If the engine has been running, allow it to cool first. Never refuel the engine inside a building where gasoline fumes can come in contact with flames or sparks.

For fuel specification, see *Fluids and Lubricants on page 32*. Refer to the engine manual for additional information on fuels.

1. Clean the area around fuel tank cap. Fill the tank to 1/2" (12 mm) below bottom of filler neck to provide space for any fuel expansion. Do not overfill.
2. Install fuel fill cap securely and wipe up any spilled fuel.

### 6.7 Engine Air Cleaner

A dirty air filter can restrict air flow to the carburetor, reducing engine performance. If the engine is operated in very dusty areas, clean the air filter more often than specified.

**IMPORTANT!** Operating the engine without an air filter, or with a damaged air filter, can allow dirt to enter the engine, causing rapid engine wear. This type of damage is not covered by Warranty.

#### Inspection

Remove the air cleaner cover and inspect the filter elements. Clean or replace dirty filter elements. Always replace damaged filter elements.

 **NOTE:** Refer to the engine manual for further information on servicing the air cleaner.

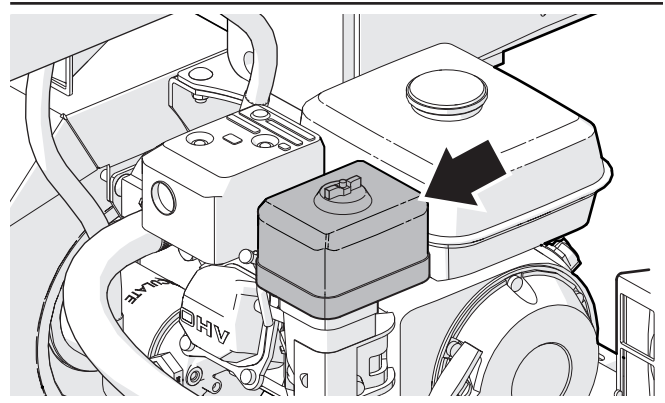



Fig. 14–Engine Air Cleaner

## 6.8 Machine Set-up

**IMPORTANT!** Park the wood splitter on a level, dry work area free of debris and other objects.

Position the splitter so the prevailing wind blows engine exhaust away from the operator.

 **NOTE:** If using a tow vehicle, leaving the splitter attached to it provides greater stability.

1. Position the splitter next to the wood to be split.
2. If no tow vehicle is available, lower the front crank jack and the rear jack stand. Chock the wheels so the machine is stable.
3. Make sure working area is clear of stones, branches or other obstacles.
4. Precut logs to desired block size, ready to load onto splitter bed.
5. Determine where the split wood is going to be piled. Make sure that location does not interfere loading splitter.

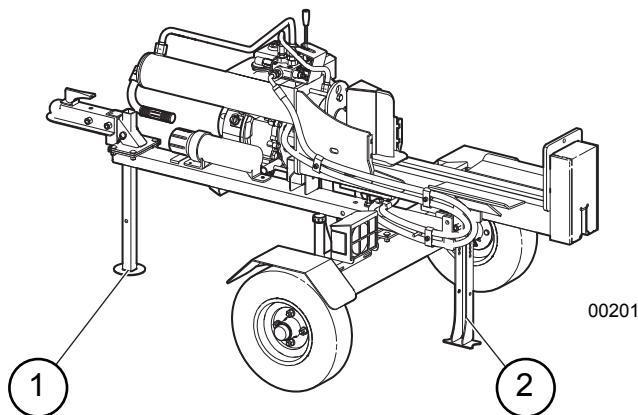
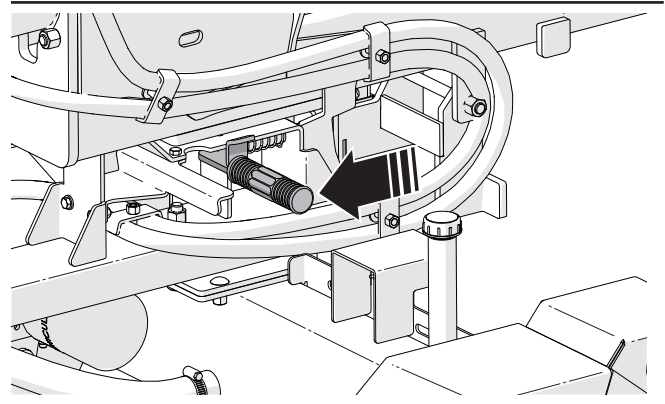

**Fig. 15–Set-up**

1. Crank Jack, Snap Lock Pin
2. Jack Stand

### Change Splitter Bed from Horizontal to Angled Position

6. Pull back on the spring latch to release the locking mechanism. Lift the frame using the handle on the end of the cylinder. While raising the splitter, release the spring latch.
7. Raise the splitter bed up 20° to the angled position. Make sure the spring latch pin locks into the hole.



**Fig. 16–Splitter Bed Spring Latch**

### Change Splitter Bed to Fully Vertical Position

8. Pull back on the spring latch to release the locking mechanism. Lift the frame using the handle on the end of the cylinder.
9. Push the splitter bed over to vertical. In the fully vertical position, the base of the splitter bed lifts the wheels slightly, so the splitter does not roll.

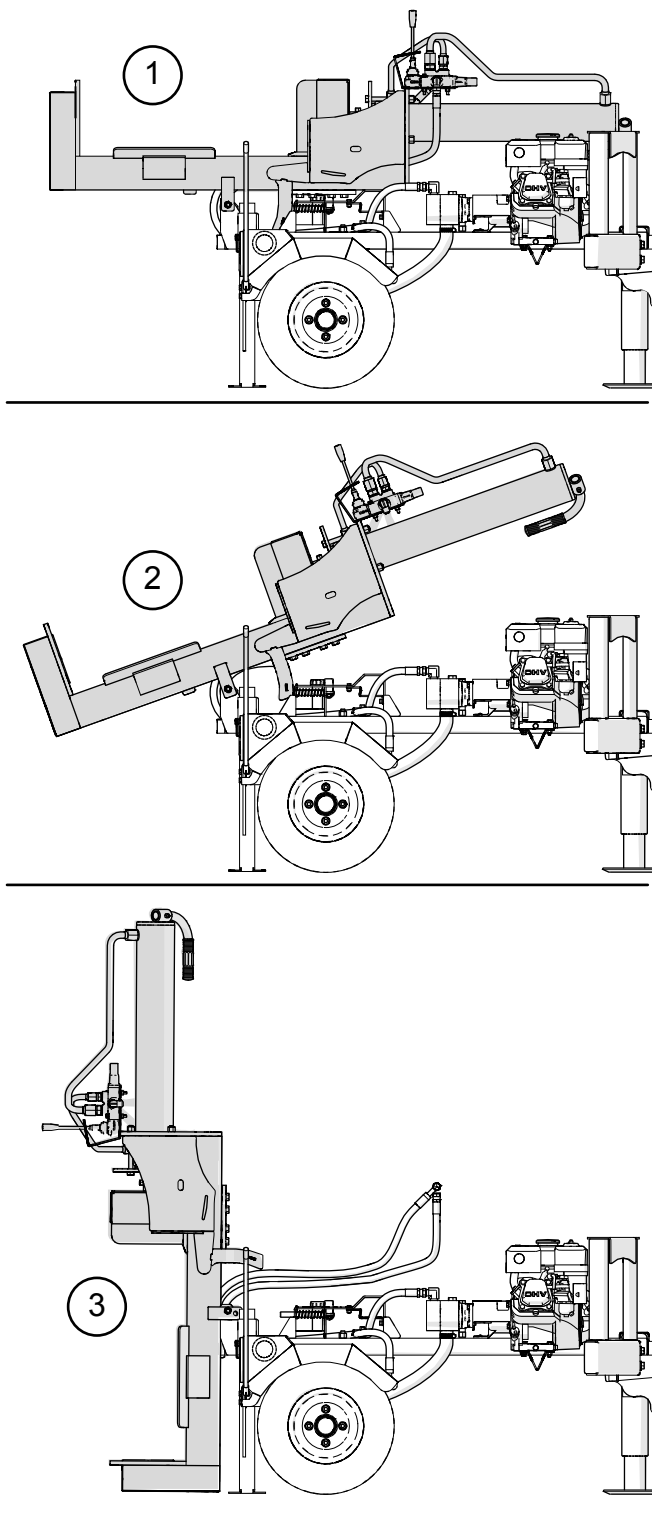

**Fig. 17–Tilting Splitter Bed Positions**

1. Horizontal Splitting
2. Angled Splitting
3. Vertical Splitting

## 6.9 Starting the Engine

### **! CAUTION!**

Before starting engine, review the operating and maintenance instructions in the engine manual.

W019

### **! CAUTION!**



Hearing loss hazard. Prolonged exposure to loud noise may cause permanent hearing loss. Use suitable protection while operating the machine.

W016

Make sure the wood splitter is set up to work and otherwise ready to run.

1. If the engine is cold, close the choke (push choke lever to the left). To start a warm engine, leave the choke open (lever pushed to the right).

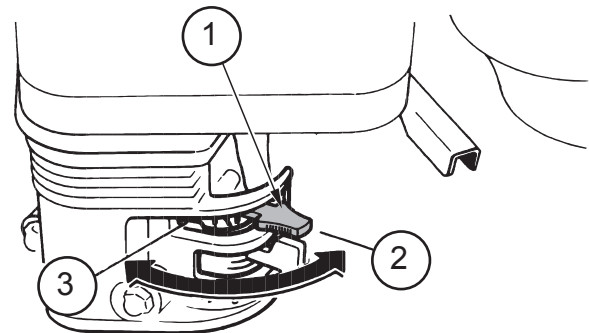

00188

**Fig. 18–Choke Lever**

1. Choke Lever
2. Choke OPEN
3. Choke CLOSED

2. Move the throttle lever away from the MIN. position, about 1/3 of the way toward the MAX position.

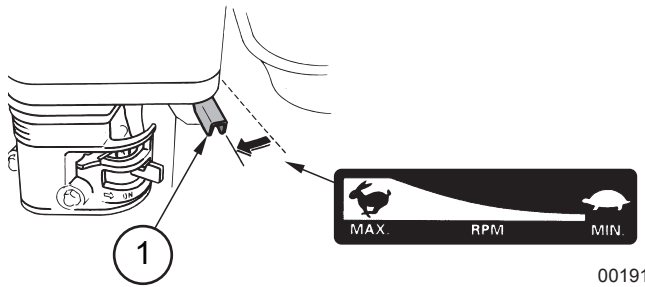

00191

**Fig. 19**–Engine Throttle

1. Throttle Lever

3. Turn the engine ignition switch ON.

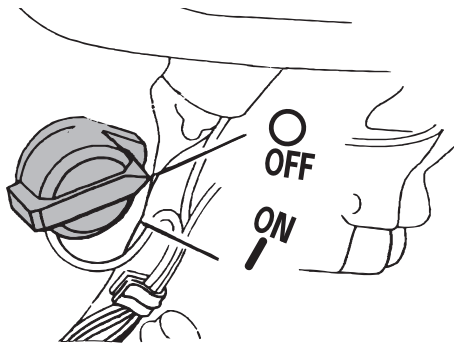

00187

**Fig. 20**–Ignition Switch

4. Pull the starter grip out lightly until resistance is felt, then pull briskly in the direction of the arrow as shown below. Return the starter grip gently.

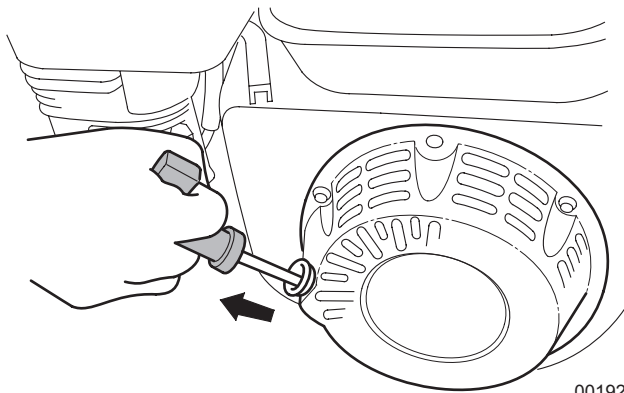

00192

**Fig. 21**–Recoil Starter

**IMPORTANT!** Do not allow the starter grip to snap back against the engine. Return it gently to prevent damage to the starter.

5. Leave the engine operating at low throttle for a few minutes to allow it to warm up. Gradually push the choke control lever open (to the left) as the engine warms.

**IMPORTANT!** Engine should be warmed up before putting to work.

6. Once the engine is warmed, increase the throttle setting to **MAX** before beginning.

## 6.10 Stopping Procedure

1. Stop loading material onto the splitter bed.
2. Decrease engine speed to **MIN**.
3. Turn the ignition switch OFF.

## 6.11 Stopping in an Emergency

### In an emergency

- Turn the ignition switch OFF.
- Correct fault situation before restarting engine and resuming work.

## 6.12 Log Placement

**! WARNING!**

**Risk of pinching or crushing hazard between the wedge or push block and the log!**

**Never place hands at the ends of the log. Always grasp logs by the sides when loading or removing.**

W035

- **Always grasp the log by the sides not the ends when placing in or removing logs from the splitter.** This minimizes the chance of the operator getting fingers, hands or arm between the wedge / push block and the log.
- Any logs or debris remaining on the splitter bed should only be removed after it is safe to do so.

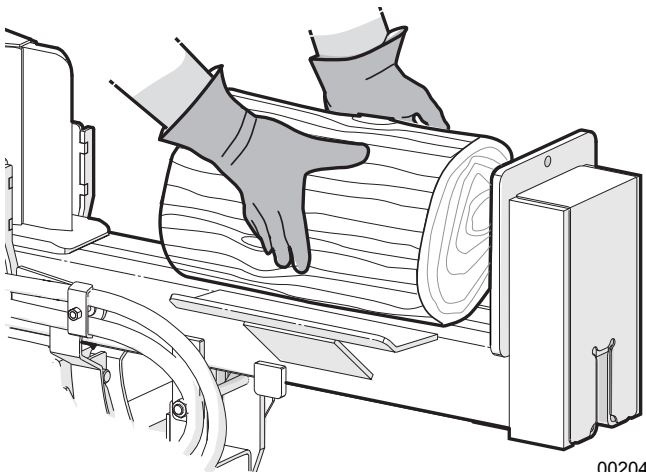

Fig. 22—Correct Log Placement

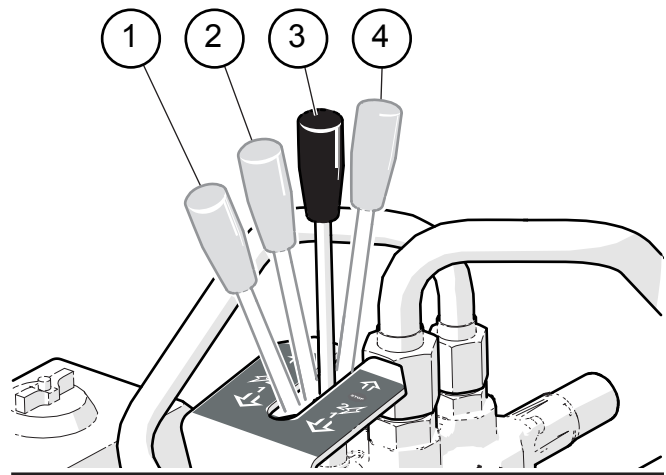

Fig. 23—Hydraulic Control Valve Positions

1. High Power
2. High Speed
3. STOP (Neutral)
4. Retract

## 6.13 Operating Hints

### **! WARNING!**

**Risk of pinching or crushing hazard! The worker loading the splitter MUST be the only one in control of the hydraulic cylinder and splitting wedge.**

**Only one worker should operate and load the wood splitter.**

W036

1. Place wood or log on the splitter.
2. Move control lever to the High Speed position (2) until push block or wedge starts to split the wood.
3. If the wedge slows, push control lever forward to High Power position (1) and hold to split wood.
4. Release the lever when the log splits or cylinder reaches full stroke and stops.
5. Pull the lever back to retract the push block or wedge. The detent holds the lever until the cylinder fully retracts, allowing hands-free operation.

**IMPORTANT!** Do not hold the valve lever to extend or retract the cylinder once it has reached the end of its stroke. Doing so can overheat the oil and could damage the engine.

6. If the log is large enough to require another split, reposition and repeat steps.
7. Pile the split wood close to the working area, but do not allow pieces to pile up and clutter the area. A cluttered working area can lead to tripping and an accident.

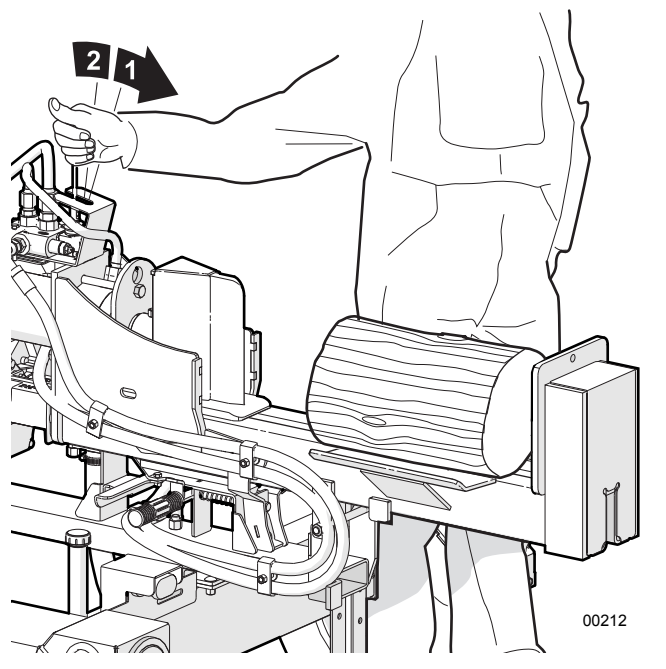

00212

Fig. 24—High Speed (2), High Power (1)

## Vertical Splitting

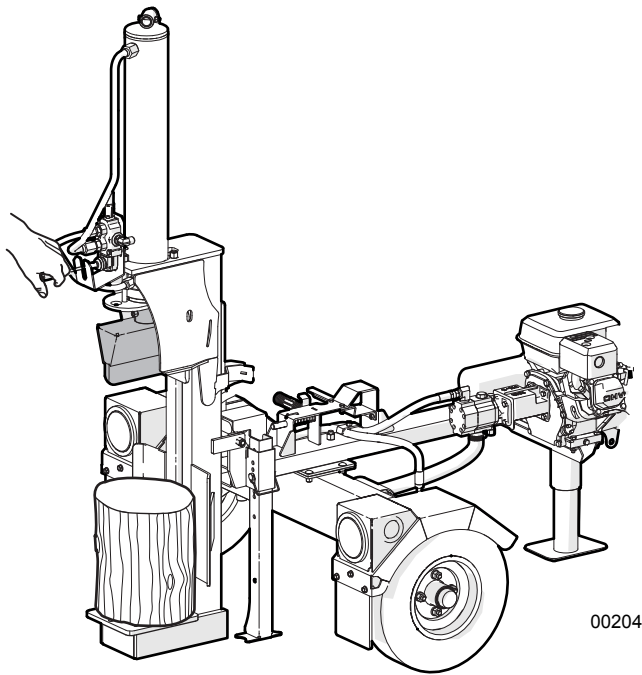

Fig. 25—Vertical Splitting

## 7. Transporting

### 7.1 Prepare for Transport

- Make sure the pivoting main frame is fully lowered to horizontal. The lock pin in the pivoting splitter beam must be fully engaged.

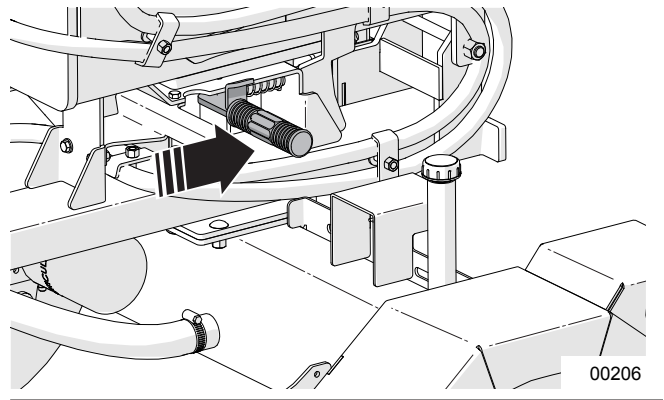

Fig. 26—Lock Pin Fully Engaged

- Turn the fuel OFF when transporting.

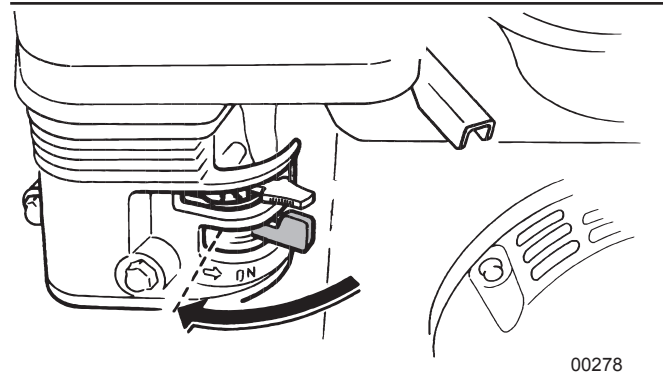

Fig. 27—Fuel Valve OFF

- Clean all debris from the splitter that could fall off in transport.
- Check tire pressure. Inspect for cuts or damaged rims.
- Check lug nuts and re-torque as necessary. Inspect again after 20–25 mi (32–40 km). Check weekly. See *page 39*.
- Inspect and replace any axle dust caps that are missing, damaged or leaking.
- Always be in compliance with all applicable local regulations when transporting.

## 7.2 Connecting a Tow Vehicle

1. Keep bystanders are clear of the machine.
2. Make sure there is enough room and clearance to safely back up to the machine.
3. Slowly back the tow vehicle until the coupler on the hitch and ball are aligned.

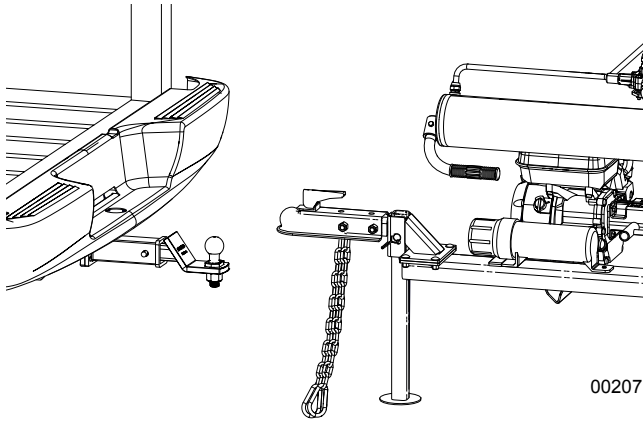

Fig. 28—Ball Hitch Aligned

4. Lift the hitch and place the coupler over the ball on the hitch.
5. Flip the latch to lock the coupler around the ball.
6. Raise the rear jack stand and secure with the snap lock pin.
7. Cross safety chains under trailer tongue and attach securely to the tow vehicle hitch.
8. Connect the wiring harness for the lights (as equipped).
9. Reverse the above procedure when unhooking.

## 8. Storing the Wood Splitter

After the season's use and the wood splitter is going to be put away in storage, it should be thoroughly inspected and prepared. Repair or replace any worn or damaged components to prevent any unnecessary down time at the start of next season. The wood splitter can have a long, trouble-free life by following these steps:

**IMPORTANT! Refer to the engine manufacturer's manual for information specific to engine storage.**

1. Fully retract the cylinder ram.
2. Thoroughly wash the machine using a pressure washer to remove all dirt, mud, debris, and residue.
3. Inspect the wedge, cylinder ram, push block and wear plates for damage or entangled material. Repair or replace damaged parts. Remove all entangled material.
4. Touch up all paint nicks and scratches to prevent rusting.
5. Turn fuel valve OFF.
6. If the splitter is to be stored for longer periods (over 6 months), follow the engine manufacturers recommendations for storage preparation.
7. Store the machine in an area away from human activity.
8. Select an area that is dry, level and free of debris to park the wood splitter.
9. If the wood splitter is not stored inside a building, cover with a waterproof tarp. Tie securely in place.
10. Do not allow children to play on or around the stored machine.

### 8.1 Removing from Storage

1. Review and follow the Pre-operation Checklist. See *page 34*
2. Review safety and operation procedures. See *page 9*.

## 9. Service and Maintenance



### WARNING!

Risk of serious personal injury. Stop engine before performing ANY service or maintenance procedure. Reinstall all covers and guards removed before putting machine back into service.

W033

**IMPORTANT!** Review Maintenance Safety on page 14 before servicing or repairing. Place the machine in a Safe Condition before performing any maintenance. See page 10.

Allow the engine to cool. Engine components and oil may be hot enough to cause injury.

**IMPORTANT!** Refer to the engine manufacturer's manual for engine maintenance and service information.

### 9.1 Fluids and Lubricants

#### 1. Engine Oil

SAE 10W-30 or 5W-30 motor oil is recommended for general use. Refer to the engine manufacturer's manual for maintenance and service information

#### 2. Grease

Use an SAE multi-purpose high temperature grease with extreme pressure (EP) performance. Also acceptable is an SAE multipurpose lithium-based grease.

#### 3. Engine Fuel

This engine is certified to operate on unleaded gasoline with a pump octane rating of 86 or higher (a research octane rating of 91 or higher).

#### 4. Hydraulic Oil

Use Dexron® III Automatic Transmission Fluid (ATF). Dexron VI or Mercon® ATF are also acceptable substitutions.

#### 5. Storing Lubricants

Your machine can operate at top efficiency only if clean lubricants are used. Use clean containers to handle all lubricants. Store them in an area protected from dust, moisture and other contaminants.

## 9.2 Maintenance Schedule

Perform maintenance procedures at time shown or hour interval, whichever comes first.

### As Required

Check the condition of all hydraulic lines, hoses and fittings. Replace any that are damaged.

Remove any entangled material from splitter.

Check that all fasteners are tight.

### Every 8 hours or Daily

Check fuel level	See page 25
------------------	-------------

Check engine oil level.	See page 24
-------------------------	-------------

### Every 50 hours or Annually

Check hydraulic oil level.	See page 24
----------------------------	-------------

Clean engine air filter	See page 25
-------------------------	-------------

Inspect hydraulic oil quality	See page 24
-------------------------------	-------------

Grease frame slide, hinges, pivot points	See page 33
------------------------------------------	-------------

### Every 100 hours or Annually

Grease axle bearings	See page 33
----------------------	-------------

Change engine oil	See engine manual
-------------------	-------------------

Check tire pressure	See rating on tire sidewall
---------------------	-----------------------------

Change hydraulic oil and filter	See page 34
---------------------------------	-------------

Change engine air filter	See page 25
--------------------------	-------------

Clean machine. Remove debris and entangled material.	—
------------------------------------------------------	---

Change fuel filter	See engine manual
--------------------	-------------------



### 9.3 Grease Points

Use a hand-held grease gun for all greasing. Pump one shot of grease per fitting.

- Wipe grease fitting with a clean cloth before greasing to avoid injecting dirt and grit.
- If fittings do not take grease, remove and clean them thoroughly. Replace grease fittings as necessary.

Location	Grease Points – Every 40 hours of operation or annually
1	Frame slide

Location	Grease Points – Every 100 hours of operation or annually
2	Axle bearings, one per side

#### WXR545PL

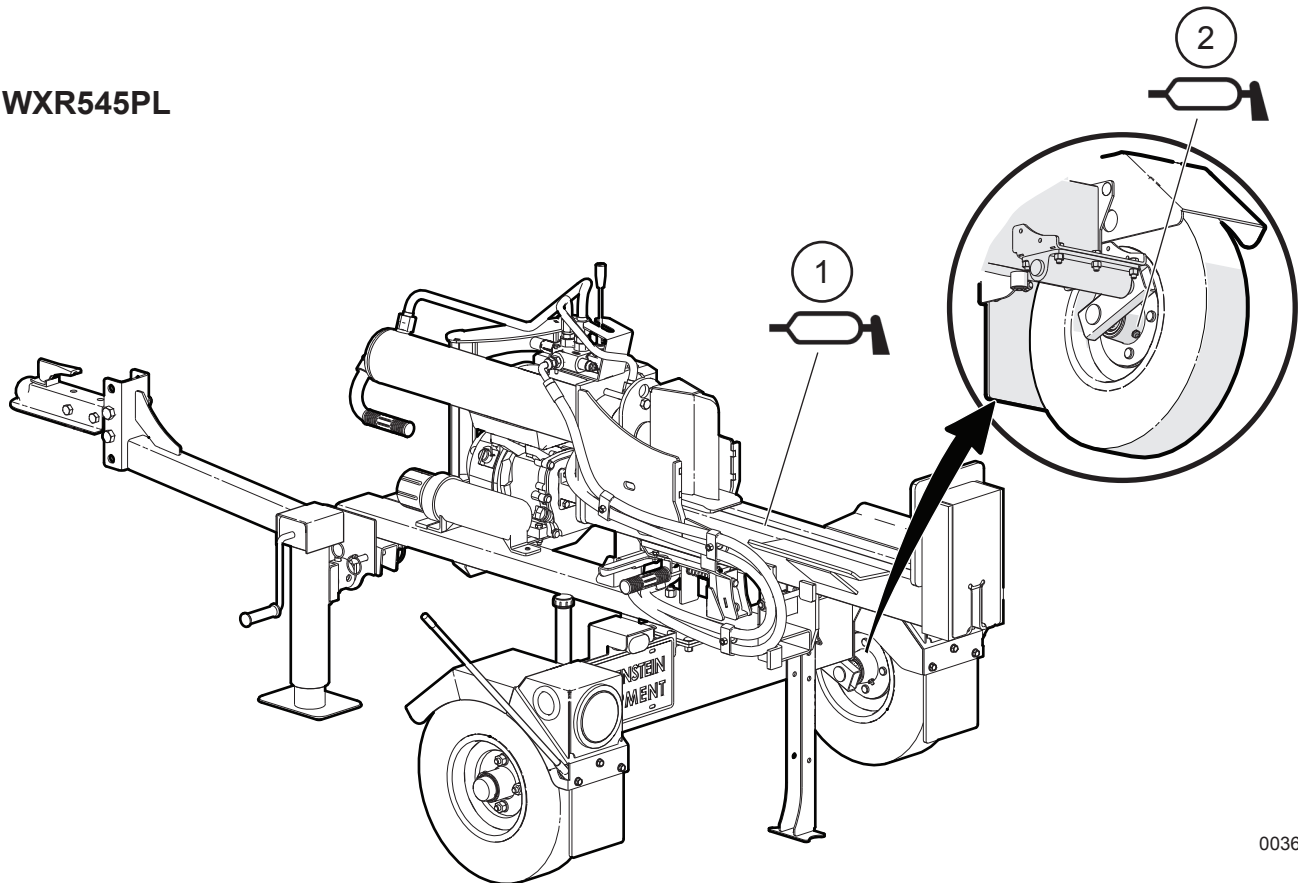

00365

Fig. 29 – Grease Points

## 9.4 Hydraulic Oil – Changing

Change the hydraulic oil at 100 hours of operation or annually.

Use Dexron® III Automatic Transmission Fluid (ATF). Dexron III does not change thickness with the outside temperature like hydraulic fluid does, resulting in more consistent performance and less possibility of damage to the pump. Dexron VI or Mercon® ATF are also acceptable substitutions.

### CAUTION!



Risk of burns to exposed skin. Hydraulic oil becomes hot during operation. Hoses, lines and other parts become hot as well. Wait for the oil and components to cool before starting any maintenance or

- Hydraulic oil type: **Dexron® III ATF**

The hydraulic tank drain plug is located under the machine. An Allen (hex) wrench is required to remove it.

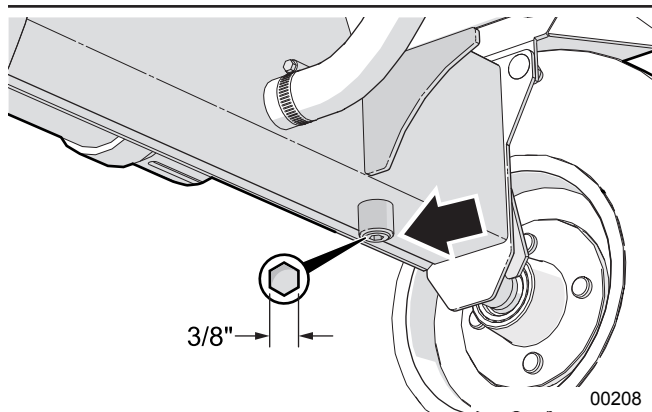

Fig. 30 – Hydraulic Tank Drain Plug

### Procedure

- Place a drain pan of suitable capacity under the drain plug.
- Clean the area around drain and remove the drain plug.
- Allow the oil to fully drain, then flush the tank.
- Replace the plug and fill the tank with clean oil.
- Dispose of used oil in an environmentally safe manner.

## 9.5 Hydraulic Oil Filter – Changing

Change hydraulic oil filter at 100 hours of operation or annually.

The filter is located on top of the hydraulic oil tank.

Place the machine in a **Safe Condition**. See page 10.

### CAUTION!



Risk of burns to exposed skin. Hydraulic oil becomes hot during operation. Hoses, lines and other parts become hot as well. Wait for the oil and components to cool before starting any maintenance or

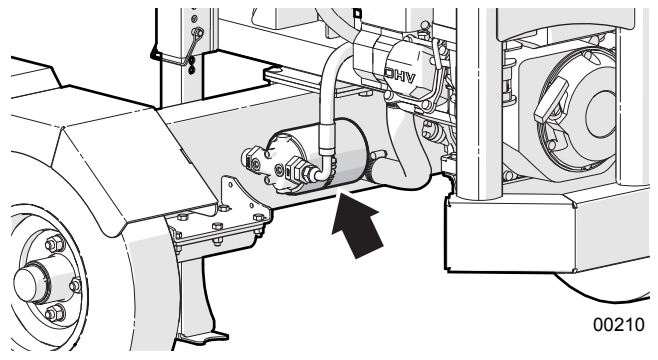

Fig. 31 – Hydraulic Oil Filter

## Procedure

1. Place a drain pan of suitable capacity under the filter head.
2. Remove the oil filter. An oil filter wrench may be required.
3. Apply a light coat of clean oil to the seal and install the new filter. Tighten by hand only.
4. Run the machine for 1–2 minutes operating the cylinder. Check filter head for oil leaks.
5. If a leak is found, shut off the machine and correct it.
6. Check hydraulic reservoir oil level. Top up as required.
7. Dispose of spilled oil in an environmentally safe manner.

## 9.6 Engine Air Cleaner

**Check air filter every 50 hours of operation. Change air filter elements at 100 hours of operation or annually.**



**NOTE:** Refer to the engine manual for information on servicing the air cleaner.

A dirty air filter can restrict air flow to the carburetor, reducing engine performance. If the engine is operated in very dusty areas, clean the air filter more often than specified.

---

**IMPORTANT!** Operating the engine without an air filter, or with a damaged air filter, can allow dirt to enter the engine, causing rapid engine wear. This type of damage is not covered by Warranty.

---

## Inspection

Remove the air cleaner cover and inspect the filter elements. Clean or replace dirty filter elements. Always replace damaged filter elements.

## 9.7 Electrical System – General

---

**IMPORTANT!** When assembling or replacing wire harnesses, apply a thin coating of silicone dielectric grease to the harness connectors.

Clean off any corrosion or loose particles, then apply a small amount to the surfaces of the connectors where they meet. The grease helps to stop any possibility of future corrosion.

Reassemble the connection. If grease squeezes out, wipe off with a rag or towel.

---

## 10. Troubleshooting

The following table lists some problems that may be encountered, with possible causes and solutions.

If a problem persists after reading through the Troubleshooting section, contact the local dealer, distributor or Wallenstein. Have the machine serial number ready.

### Engine related issues

Refer to the Honda GX200 owner's manual found in the manual tube.

Problem	Cause	Solution
<b>Cylinder rod moves slowly or does not move. Screeching or hissing noise.</b>	No hydraulic oil pressure.	Oil filter plugged. Change filter.
		Low hydraulic oil level. Add oil.
		System relief pressure setting too low. Call technician.
	Wood jammed around wedge.	Shut machine off and safely remove wood.
	Low engine speed.	Check throttle is set to maximum. Check that choke is off.
<b>Control handle does not go to neutral after rod is fully retracted.</b>	Valve detent set too tight.	Adjustment required to detent on valve.
	Hydraulic oil too cold.	Allow machine to warm up.
	Hydraulic fluid is contaminated.	Change hydraulic fluid and filter.
<b>Control handle goes to neutral before rod is fully retracted.</b>	Detent set too loose.	Adjustment required to detent on valve.
<b>Control handle does not go to neutral when released.</b>	Control may be damaged.	Control may need service or be replaced. Call technician.
<b>Cylinder stops on contact with wood.</b>	Second stage on pump not functioning.	Pump may need to be serviced or replaced. Call technician.
<b>Wedge or push block jumps.</b>	Wedge or push block frame jamming.	Lubricate slider wear plates.
<b>Leaking hydraulic hose.</b>	Hose worn or damaged.	Replace hose.
<b>Leaking cylinder.</b>	Seals worn.	Seal replacement may be required. Call technician.

## 11. Specifications

### 11.1 Machine Specifications<sup>1</sup>

Model	WXR545PL
Mounting	Trailer Mounted
Engine Model	Honda GX200
Engine Displacement	200 cc
Cylinder Diameter	4.0 " (101.6 mm)
Cylinder Stroke	24" (610 mm)
Splitting Force	22 ton
Valve Type	4-position, Spring-return to neutral
Hydraulic Pump Type	2-stage
Hydraulic Pump Flow	11 gpm (42 Lpm)
Bed Height	24" (61 cm)
Wedge Height	9" (23 cm)
Tire Size	4.80-8 LRB SportTrail 4on4
Tire Type	Highway
Safety Chains	Standard
Ball Hitch Size	2.0"
Auto Return to Neutral	Yes
Splitter Orientation	Horizontal / Vertical / Angled
Average Cycle Time	5 seconds
Full Cycle Time	10.3 seconds
Weight	625 lb (283 kg)
Dimensions (L x W x H)	108 x 49 x 45 in
	274 x 124 x 114 cm
Accessories	Clamp-on Shelf Extension (W4211)
	Stroke Limiter (W4213)
	4-Way Splitting Wedge (W4130)

<sup>1</sup> Specifications subject to change without notice.

## 11.2 Common Bolt Torque Values

### Checking Bolt Torque

The tables shown give correct torque values for various bolts and capscrews. Tighten all bolts to the torque values specified in the table, unless indicated otherwise. Check tightness of bolts periodically.

**IMPORTANT!** If replacing hardware, use fasteners of the same grade.

**IMPORTANT!** Torque figures indicated in the table are for non-greased or non-oiled threads. Do not grease or oil threads unless indicated otherwise. When using a thread locker, increase torque values by 5%.

 **NOTE:** Bolt grades are identified by their head markings.

Imperial Bolt Torque Specifications						
Bolt Diameter	Torque Value					
	SAE Gr. 2		SAE Gr. 5		SAE Gr. 8	
	lbf•ft	N•m	lbf•ft	N•m	lbf•ft	N•m
1/4"	6	8	9	12	12	17
5/16"	10	13	19	25	27	36
3/8"	20	27	33	45	45	63
7/16"	30	41	53	72	75	100
1/2"	45	61	80	110	115	155
9/16"	60	95	115	155	165	220
5/8"	95	128	160	215	220	305
3/4"	165	225	290	390	400	540
7/8"	170	230	420	570	650	880
1"	225	345	630	850	970	1320



SAE Gr. 2



SAE Gr. 5



SAE Gr. 8

Metric Bolt Torque Specifications				
Bolt Diameter	Torque Value			
	Gr. 8.8		Gr. 10.9	
	lbf•ft	N•m	lbf•ft	N•m
M3	0.4	0.5	1.3	1.8
M4	2.2	3	3.3	4.5
M6	7	10	11	15
M8	18	25	26	35
M10	37	50	52	70
M12	66	90	92	125
M16	166	225	229	310
M20	321	435	450	610
M30	1,103	1 495	1,550	2 100
M36	1,917	2 600	2,700	3 675



8.8



10.9

### 11.3 Hydraulic Fitting Torque

#### Tightening Flare Type Tube Fittings

1. Check flare and flare seat for defects that might cause leakage.
2. Align tube with fitting before tightening.
3. Hand-tighten swivel nut until snug.
4. To prevent twisting the tube, use two wrenches. Place one wrench on the connector body and tighten the swivel nut with the second. Torque to values shown.

If a torque wrench is not available, use the FFFT (Flats From Finger Tight) method.

Hydraulic Fitting Torque					
Tube Size OD	Hex Size Across Flats	Torque value		Flats From Finger Tight	
		lbf•ft	N•m	Flats	Turns
3/16	7/16	6	8	2	1/6
1/4	9/16	11–12	15–17	2	1/6
5/16	5/8	14–16	19–22	2	1/6
3/8	11/16	20–22	27–30	1-1/4	1/6
1/2	7/8	44–48	59–65	1	1/6
5/8	1	50–58	68–79	1	1/6
3/4	1-1/4	79–88	107–119	1	1/8
1	1-5/8	117–125	158–170	1	1/8

Values shown are for non-lubricated connections.

### 11.4 Wheel Lug Torque

It is extremely important safety procedure to apply and maintain proper wheel mounting torque on your trailer axle. Torque wrenches are the best method to assure the proper amount of torque is being applied to a fastener.

Wheel lugs should be torqued before first road use and after each wheel removal. Check and re torque after the first 10 miles (16 km), 25 miles (40 km), and again at 50 miles (80 km). Check periodically thereafter.



#### WARNING!

**Wheel lug nuts must be installed and kept at the proper torque value to prevent loose wheels, broken studs, or possible separation of wheels from axle.**

- Start all lug nuts onto the threads by hand.
- Tighten lug nuts in stages, following the pattern shown in the Wheel Lug Nut Torque table.

Wheel Lug Nut Torque				
Wheel Size	Units	1st Stage	2nd Stage	3rd Stage
8"	lbf•ft N•m	12–20 16–26	30–35 39–45.5	45–55 58.5–71.5
12"	lbf•ft N•m	20–25 26–32.5	35–40 45.5–52	50–60 65–78
13"	lbf•ft N•m	20–25 26–32.5	35–40 45.5–52	50–60 65–78
14"	lbf•ft N•m	20–25 26–32.5	50–60 65–78	90–120 117–156
15"	lbf•ft N•m	20–25 26–32.5	50–60 65–78	90–120 117–156
16"	lbf•ft N•m	20–25 26–32.5	50–60 65–78	90–120 117–156

Wheel Lug Torque Pattern

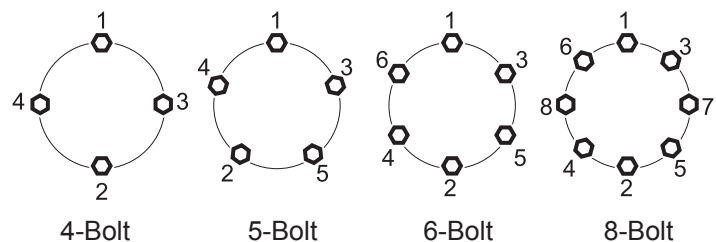

## 12. Alphabetical Index

<b>A</b>	
Adding Hydraulic Oil to the Tank .....	25
Air Cleaner Inspection .....	25
Angled Splitter Bed .....	26
<b>B</b>	
Before Starting the Engine .....	22
Bolt torque .....	38
Break-in .....	23
<b>C</b>	
Checking Bolt Torque .....	38
Choke Lever .....	20
Connecting a Tow Vehicle .....	31
Controls .....	20
Engine Controls .....	20
Hydraulic Controls .....	21
Tilting Splitter Bed .....	22
<b>D</b>	
Decal Information .....	7
Delivery Inspection Report .....	4
<b>E</b>	
Engine .....	32
Engine Air Cleaner .....	25, 35
Engine Controls .....	20
Choke Lever .....	20
Fuel Shut-off Valve .....	20
Ignition Switch .....	20
Recoil Starter .....	21
Throttle Lever .....	21
Engine Fuel .....	32
Engine Oil .....	32
Engine Oil Level Check .....	24
Equipment Safety Guidelines .....	10
<b>F</b>	
Familiarization .....	18
Job Site Familiarization .....	18
Machine Components .....	19
To the New Operator .....	18
Training .....	18
Fluids .....	32
Fuel Level - Checking .....	25
Fuel Shut-off Valve .....	20
<b>G</b>	
Gas Motor Safety .....	13
Grease Points .....	33
<b>H</b>	
How to Install Safety Signs .....	17
Hydraulic Controls .....	21
High Power Position (1) .....	22
High Speed Position (2) .....	22
Retract Position .....	22
Stop Position .....	21
Hydraulic Fitting Torque .....	39
Hydraulic Oil .....	32
Hydraulic Oil – Changing .....	34
Hydraulic Oil Level Check .....	24
Hydraulic Oil Type .....	25
<b>I</b>	
Ignition Switch .....	20
Informative Labels .....	7
Introduction .....	2
Foreword .....	2
<b>L</b>	
Log Placement .....	28
Lubricants .....	32
<b>M</b>	
Machine Components .....	19
Machine Set-up .....	26
Machine Specifications .....	37
Maintenance Decals .....	7
Maintenance Schedule .....	32
<b>O</b>	
Operating Hints .....	29
Operating Safety .....	11
Operation	
Starting the Engine .....	27
Stopping in an Emergency .....	28
Stopping Procedure .....	28
<b>P</b>	
Personal Protective Equipment (PPE) .....	9
Pre-operation .....	23
Product Labels .....	7
Product Warranty .....	6
Putting Wood Splitter in Storage	
Removing from Storage .....	31
<b>R</b>	
Refueling .....	25
Refueling Safety .....	12
Replace Damaged Safety Signs .....	17
<b>S</b>	
Safe Condition .....	10
Safety .....	8
Equipment Safety Guidelines .....	10
Gas Motor Safety .....	13
How to Install Safety Signs .....	17
Hydraulic Safety .....	12
Maintenance Safety .....	14
Operating Safety .....	11
Personal Protective Equipment (PPE) .....	9
Preparation .....	10
Refueling Safety .....	12



Safety Alert Symbol .....8  
Safety Do's and Don'ts .....9  
Safety Training ..... 10  
Signal Words .....8  
Tire Safety ..... 12  
Transport Safety ..... 11  
Safety Alert Symbol .....8  
Safety Notice Decals .....7  
Safety Sign Explanations ..... 17  
Safety Sign Locations ..... 16  
Safety Signs ..... 16  
    Safety Sign Explanations ..... 17  
    Safety Sign Locations ..... 16  
Safety Training ..... 10  
Serial Number Location .....5  
Service and Maintenance .....32  
    Electrical System .....35  
    Fluids and Lubricants .....32  
    Grease Points .....33  
    Hydraulic Oil – Changing .....34  
    Hydraulic Oil Filter – Changing .....34  
    Maintenance Schedule .....32  
Sign-off form ..... 15  
Specifications .....37  
    Hydraulic Fitting Torque .....39  
Splitter Operation .....22  
    Before Starting the Engine .....22  
    Engine Oil Level Check .....24  
    Fuel Level Check .....25  
    Hydraulic Oil Level Check .....24  
    Machine Break-In .....23  
    Pre-operation Checklist .....23  
Starter .....21  
Stopping in an Emergency .....28  
Stopping procedure .....28  
Storing the Wood Splitter .....31

**T**

Throttle Lever .....21  
Tilting Splitter Bed .....22  
Transporting .....30  
    Connecting a Tow Vehicle .....31  
    Prepare for Transport .....30  
Troubleshooting Guide .....36

**V**

Vertical Splitter Bed .....26  
Vertical Splitting .....29

**W**

Wheel Lug Torque .....39



[www.wallensteinequipment.com](http://www.wallensteinequipment.com)