

WALLENSTEIN

BY EMB MFG INC.

TRAILER SPLITTER MODELS WX530,530-L,WX540,540-L ASSEMBLY INSTRUCTION MANUAL

**Please review and understand the
operators manual before attempting
to operate this machinery.**

EMB MANUFACTURING INC.

**4144 BOOMER LINE
ST. CLEMENTS, ON
N0B 2M0 CANADA
PH: (519) 699-9283
FAX: (519) 699-4146**

1.0 ASSEMBLY SAFETY

1. Read and understand the Assembly Manual and all safety signs before starting.
2. Follow good safety practices:
 - Keep service area clean and dry.
 - Be sure electrical outlets and tools are properly grounded.
 - Use adequate light for the job at hand.
3. Use properly sized tools, stands, jacks and hoists at all times.
4. Don't handle heavy and/or bulky components alone, ask for help.
5. Position in a large open area to allow access from all sides during assembly.
6. Keep the assembly area neat and clean to prevent slipping or tripping.
7. When using lifting equipment, place jack stands under the machine to securely stabilize it before working on, beside or under it during assembly.
8. Stay away from overhead power lines and obstructions when lifting the machine during assembly. Contact with power lines can cause electrocution. Contact with obstructions can damage components or cause them to fail.
9. Tighten all fasteners to their specified torque, then recheck before using the machine.

2.0 BOLT TORQUE

ENGLISH TORQUE SPECIFICATIONS

Bolt Diameter "A"	Bolt Torque*					
	SAE 2 (N.m) (lb-ft)		SAE 5 (N.m) (lb-ft)		SAE 8 (N.m) (lb-ft)	
1/4"	8	6	12	9	17	12
5/16"	13	10	25	19	36	27
3/8"	27	20	45	33	63	45
7/16"	41	30	72	53	100	75
1/2"	61	45	110	80	155	115
9/16"	95	60	155	115	220	165
5/8"	128	95	215	160	305	220
3/4"	225	165	390	290	540	400
7/8"	230	170	570	420	880	650
1"	345	225	850	630	1320	970

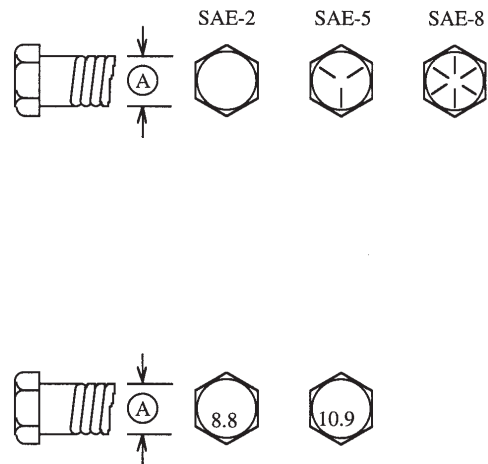

Torque figures indicated above are valid for non-greased or non-oiled threads and heads unless otherwise specified. Therefore, do not grease or oil bolts or caps crews unless otherwise specified in this manual. When using locking elements, increase torque values by 5%.

* Torque value for bolts and capscrews are identified by their head markings.

3.0 ASSEMBLY

This assembly manual is for all trailer model trailer splitters. The WX530 is used as an example but generally applies to all wood splitters. Model specific instructions are identified in the manual.

The machine is shipped from the factory in a partially disassembled configuration and attached to a pallet that provides easy moving and handling. Always use tools, equipment and fork lifts of appropriate size and capacity for the job.

Inspect for damage from shipping, immediately contact the shipping company if damage is found.

When the machine is shipped, follow this assembly procedure:

1. Clear the area of bystanders, especially small children.
2. Be sure you have all the required tools before you start.
3. Move the shipping package into an area where it is accessible from all sides.
4. Remove the screws holding the lid to the shipping pallet, remove the lid and set aside away from the assembly area.

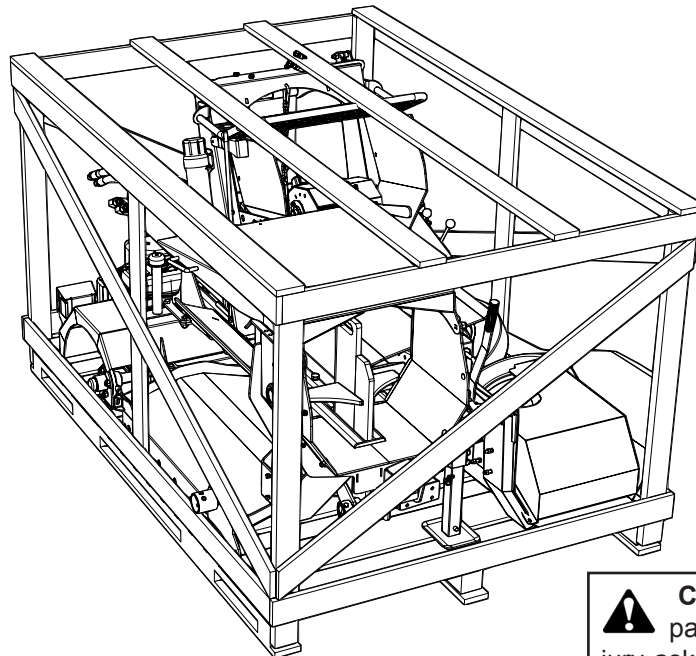

⚠ Caution: Heavy or bulky parts: prevent potential injury ask for help when lifting or moving heavy, bulky parts.

Uncrating the WX530/540 Wood Splitter

1. Remove all screws securing upper part of crate to lower skid. There are two (2) screws located at each of four (4) corners around the bottom of crate. **Photo 1**



2. Remove the upper portion of crate. **Photo 2**



3. Locate wood splitter component parts box (consisting of Fenders and Assembly Hardware), shipped on lower skid. *Photo 3*

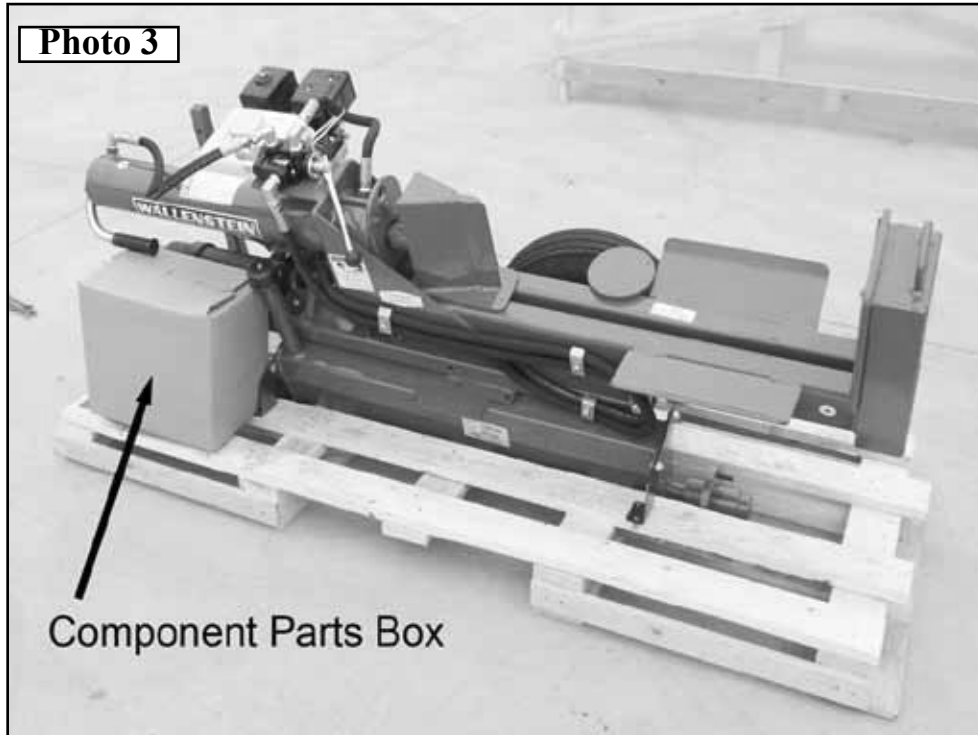

4. Remove fasteners securing the Front Jack Stand and 2" Hitch Coupler Assy. to the lower wooden skid. *Photo 4* Set both aside on a clean work surface temporarily.



5. Snip tie wraps securing tires to splitter. Remove tires and set aside temporarily. *Photo 5*



6. Loosen rear Jack Lock Handle and remove Rear Jack Stand. *Photo 6*

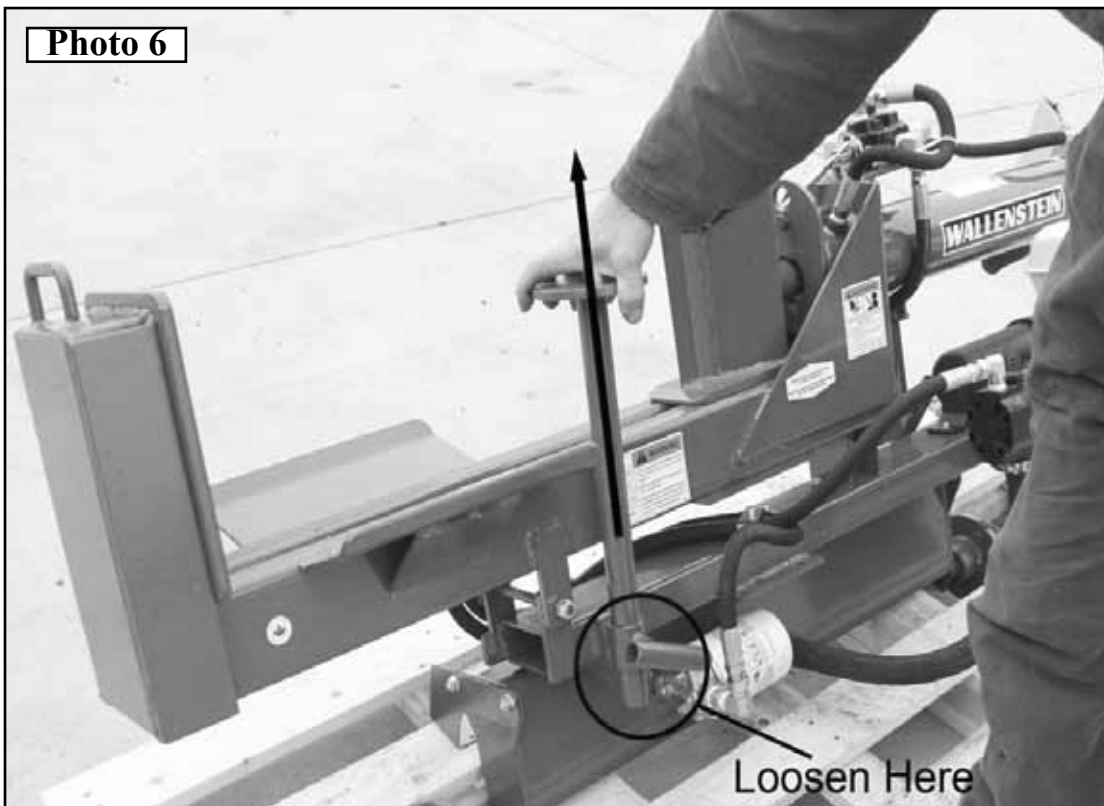

7. Remove fasteners securing shipping brace to wood skid (located same side as plastic Operator's Manual Storage Tube). *Photo 7*



8. Swing main body of Wood Splitter 90 degrees to axle. *Photo 8*

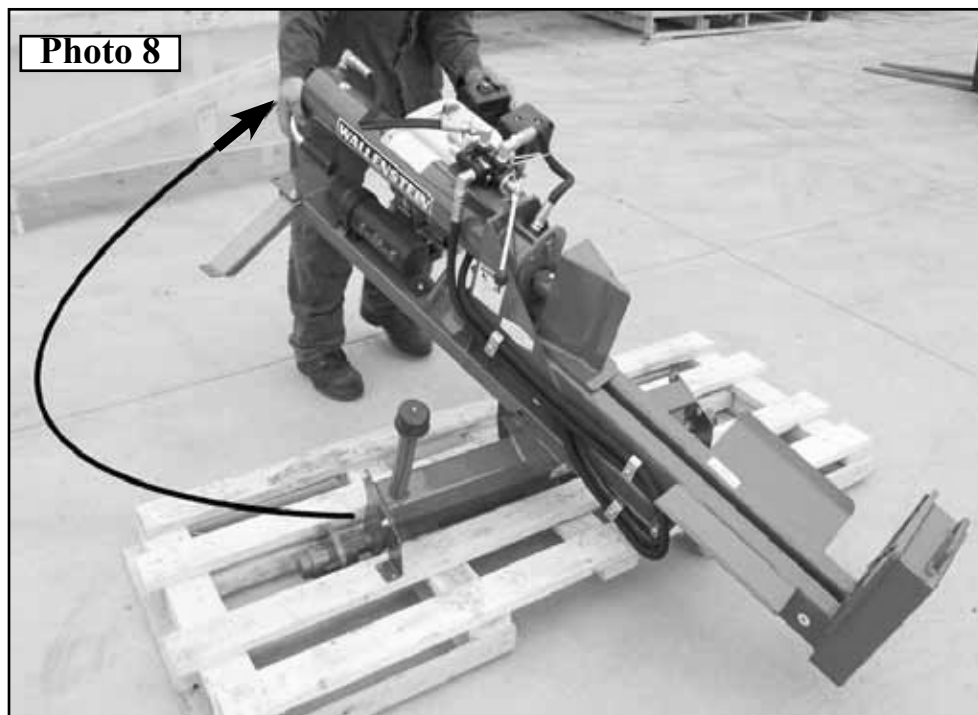

9. Install two (2) **Carriage Bolts** to left side of Weldment, H/V Rotating Base at axle and secure with two (2) **Flange Nuts** *Photo 9*

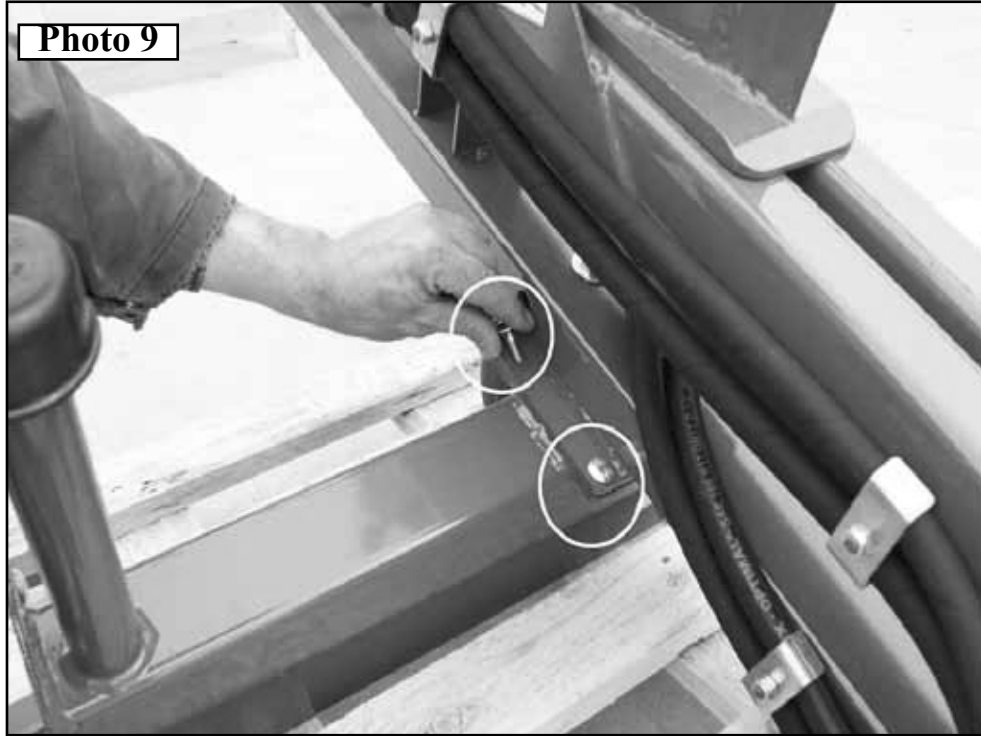

10. Install two (2) more **Carriage Bolts** at right side of Weldment, H/V Rotating Base of Splitter at axle and secure with two (2) **Flange Nuts**. *Photo 10*

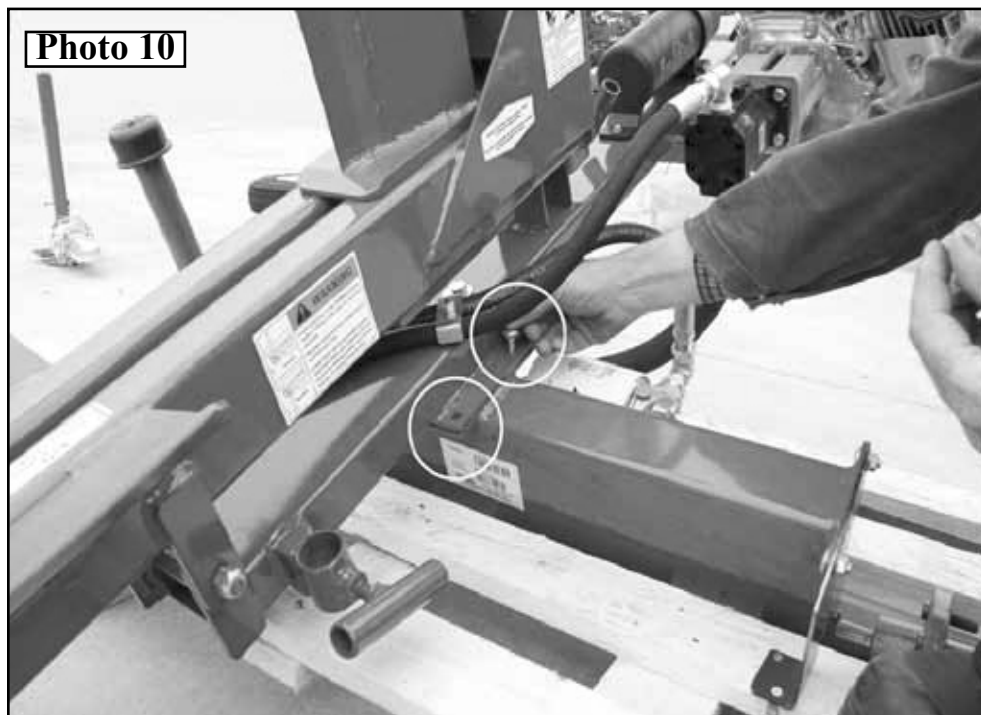

11. At front of Splitter, remove the shipping brace from front hitch area. *Photo 11*

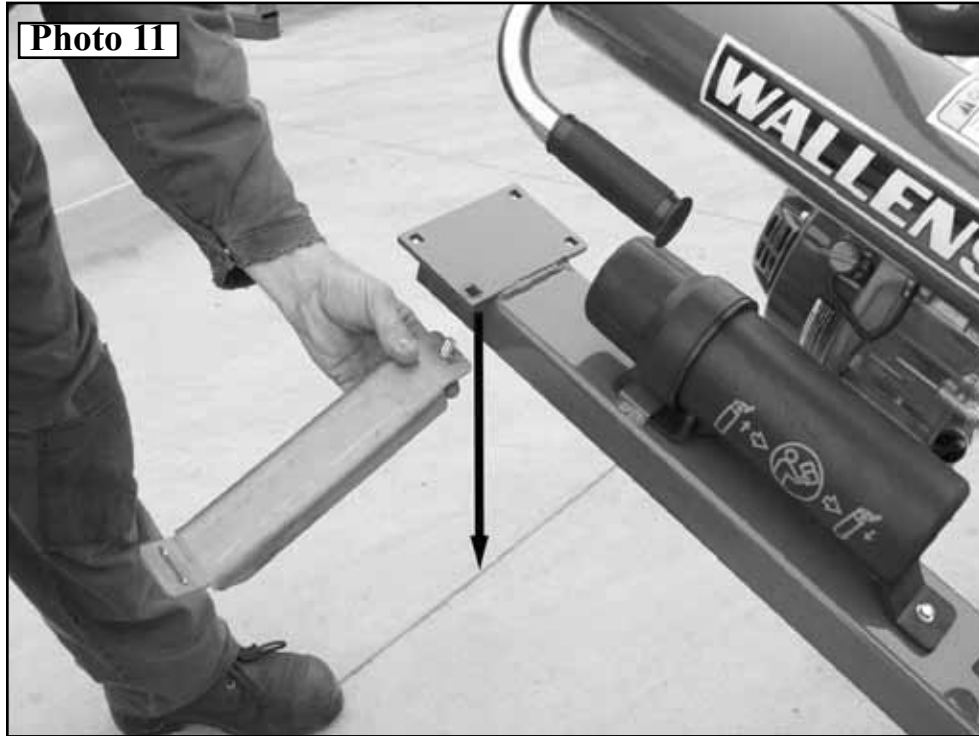

12. Locate Front Jack Stand and 2" Hitch Coupler Assy. Removed in Step 4 and slide the Hitch Coupler Assembly from the stand. *Photo 12*



13. Install the Front Hitch Coupler Assembly to the front of the Splitter using four (4) **Carriage Bolts** and securing with four (4) **Flange Nuts**. *Photo 13 & 14*

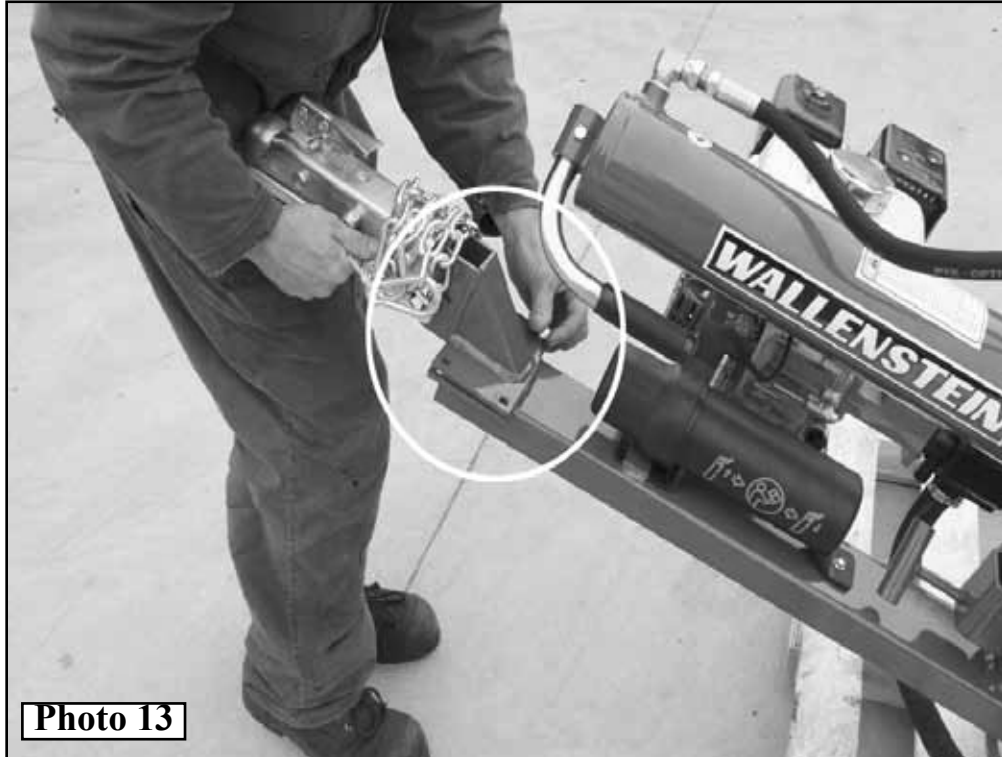

14. Slide Front Jack Stand into Hitch Coupler assembly and secure with **Snapper Pin 3/8 x 2-1/4**. *Photo 15* See Photo Inset.

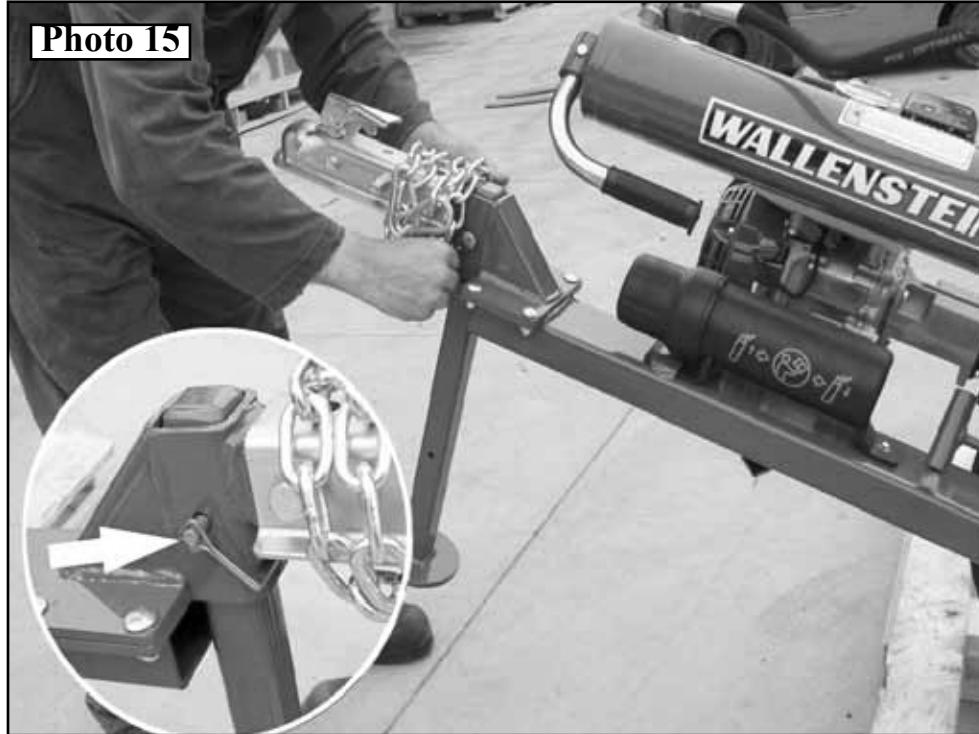

15. Remove fasteners from shipping brackets (at wood skid) securing axle assembly. There is one located on both left and right side. *Photo 16*

CAUTION

Support the back of the splitter with your free arm to gently allow the splitter to slowly tilt forward and rest on the front support. *Photo 17* following page.

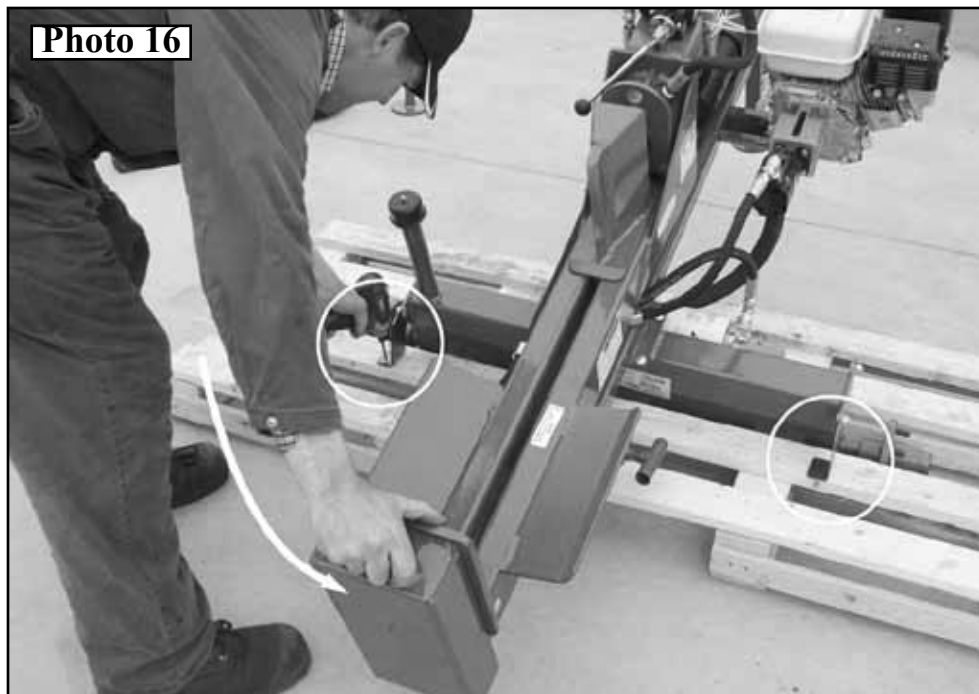

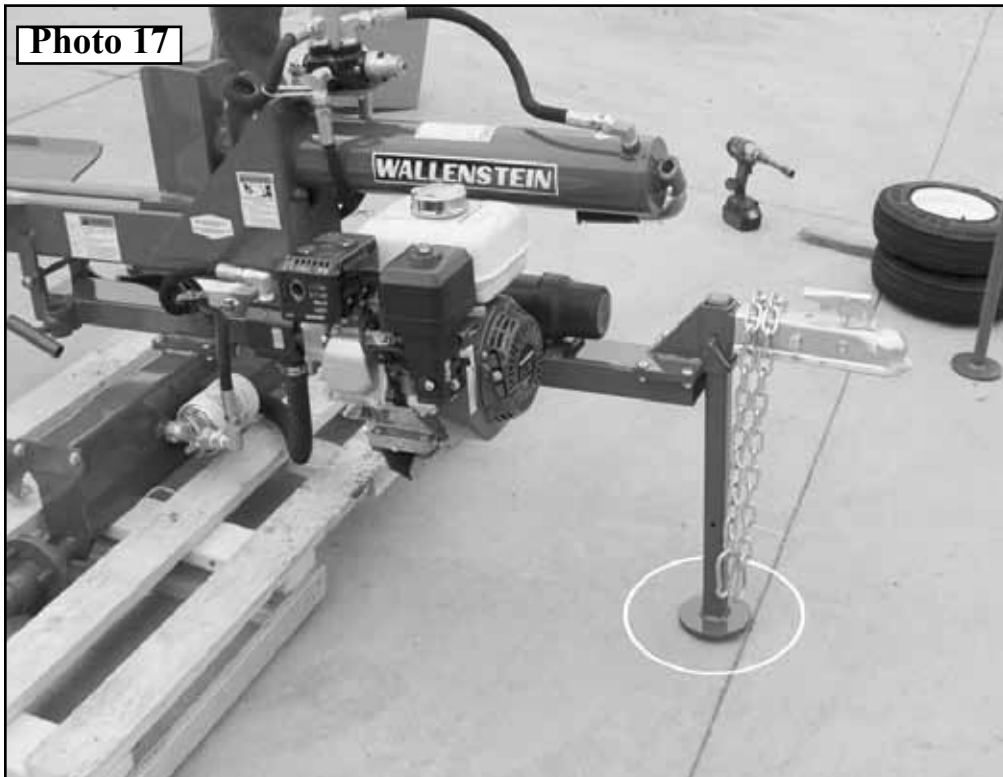

Photo 17

16. Remove fasteners securing the shipping brackets to Wood Splitter Axle (both sides).

Photos 18

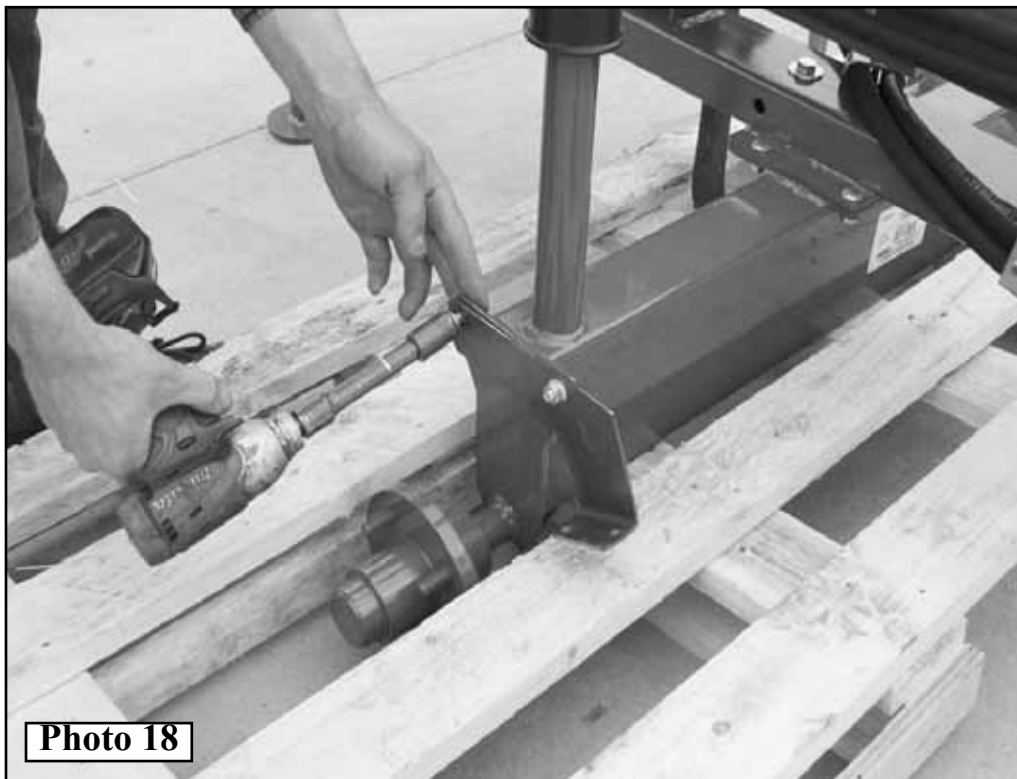
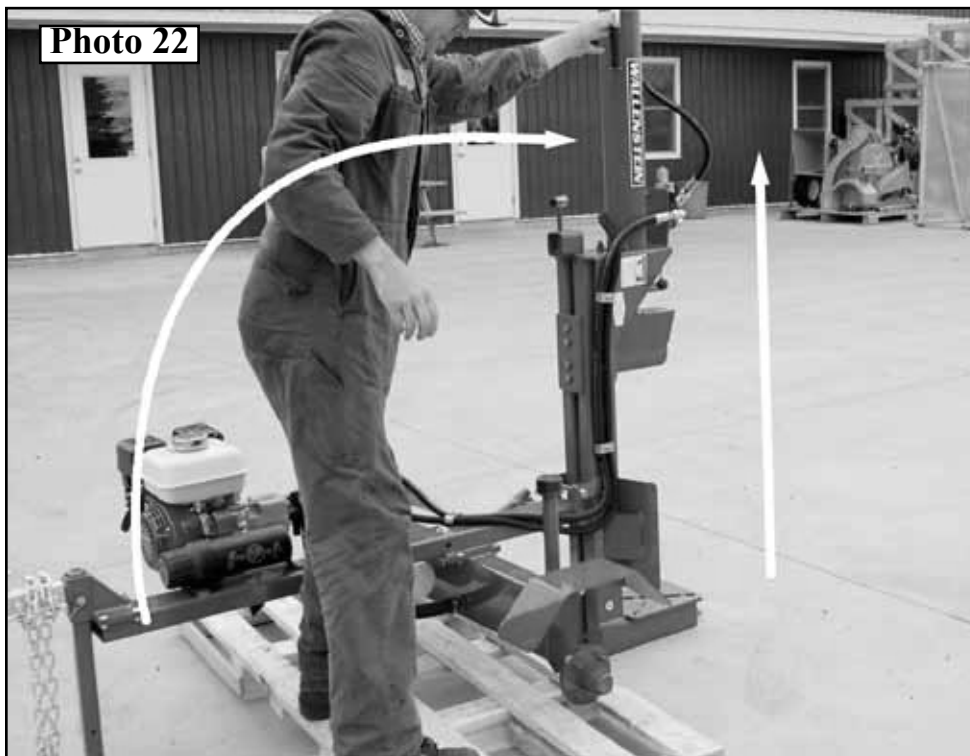
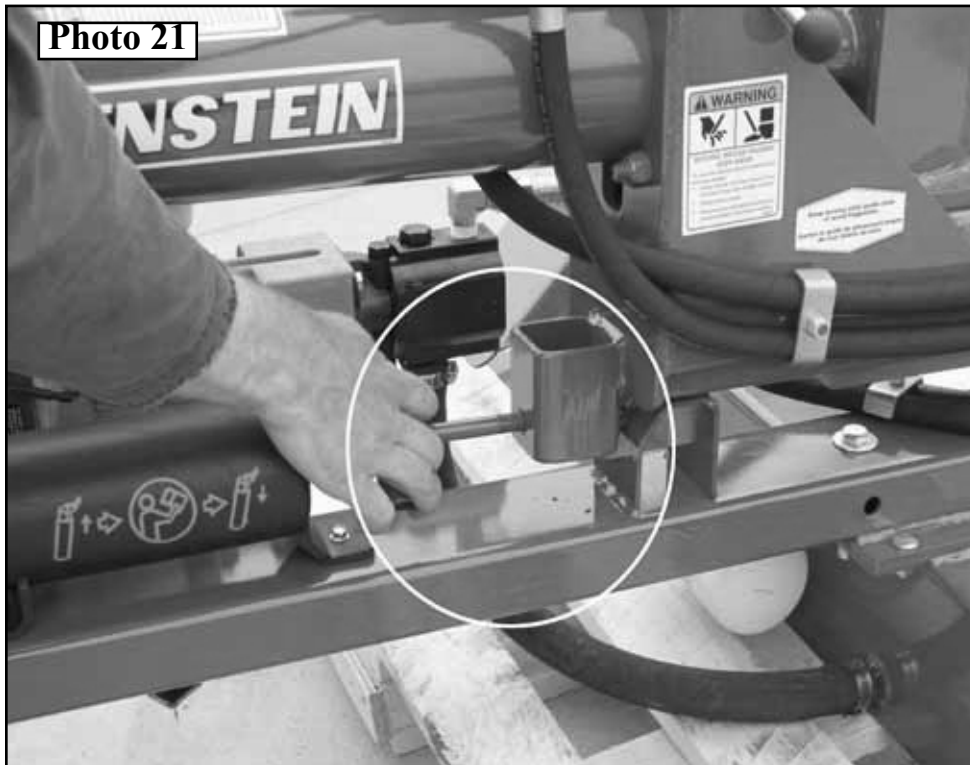

Photo 18

17. Install Fenders to right and left side of Wood Splitter. Secure each side with two (2) Carriage Bolts and Two (2) Flange Nuts. *Photo 19 & 20*



18. Pull out spring loaded Latch Handle and rotate the Splitting Frame 90 degrees to ground surface. *Photo 21 & 22*



19. Install left hand side tire and secure with four (4) Lug Nut 1/2NF. *Photo 23*



20. Remove wooden skid from beneath Wood Splitter. *Photo 24*

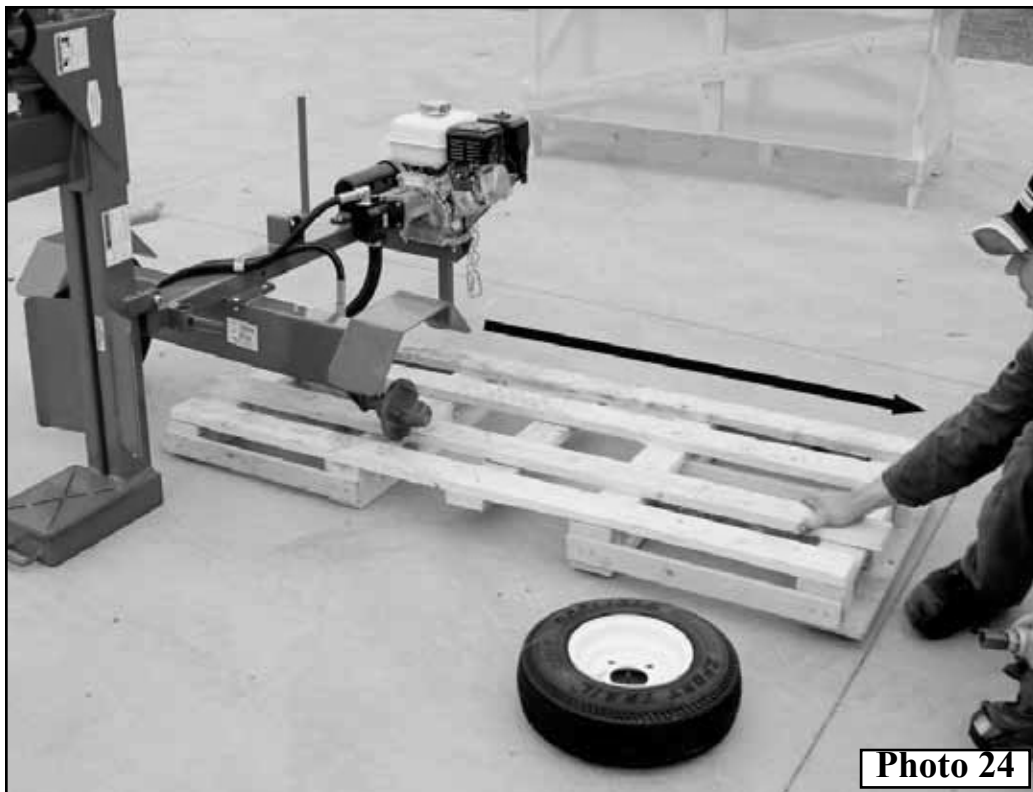

21. Install right hand side tire and secure with four (4) **Lug Nut 1/2NF**. *Photo 25*



22. Lower the Splitting Frame back into the horizontal position and snap into place at the spring loaded latch handle. *Photo 26*



23. Remove **Snapper Pin 3/8 x 2-1/4** from the Front Jack Stand and slide stand out from front of Wood Splitter. *Photo 27*

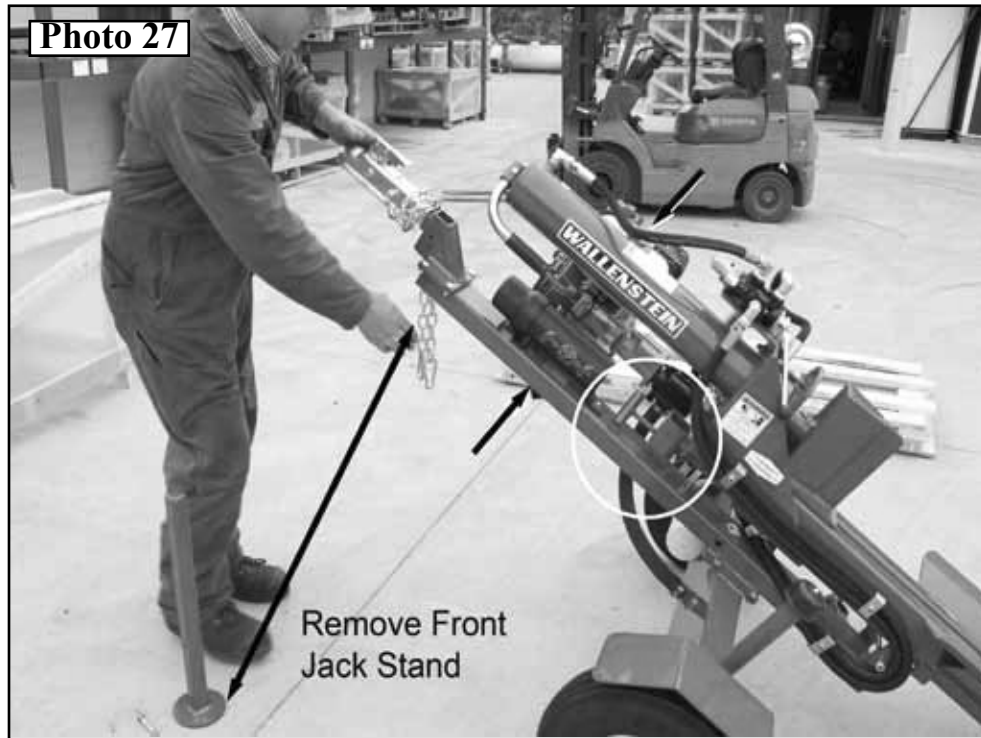

24. Gently lower the front end of the Wood Splitter down so back end is now raised off the ground. *Photo 28*

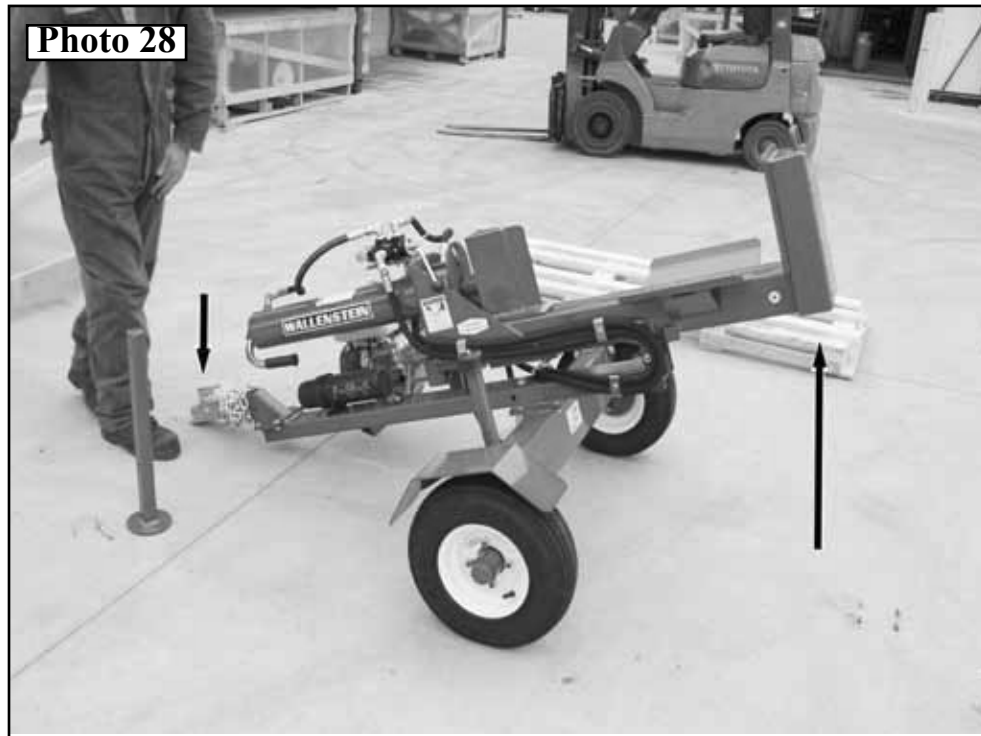

25. Slide the Rear Jack Stand into position at back of Wood Splitter and secure with Rear Jack Lock Handle. *Photo 29* Secure in raised position



26. Reinstall Front Jack Stand and secure with **Snapper Pin 3/8 x 2-1/4**. *Photo 30*



27. Locate Handle Control for Hydraulics. This handle has been shipped in the horizontal position. **Photo 31** Remove top hitch pin clip and pull pin to remove handle. See **Photo Inset**.

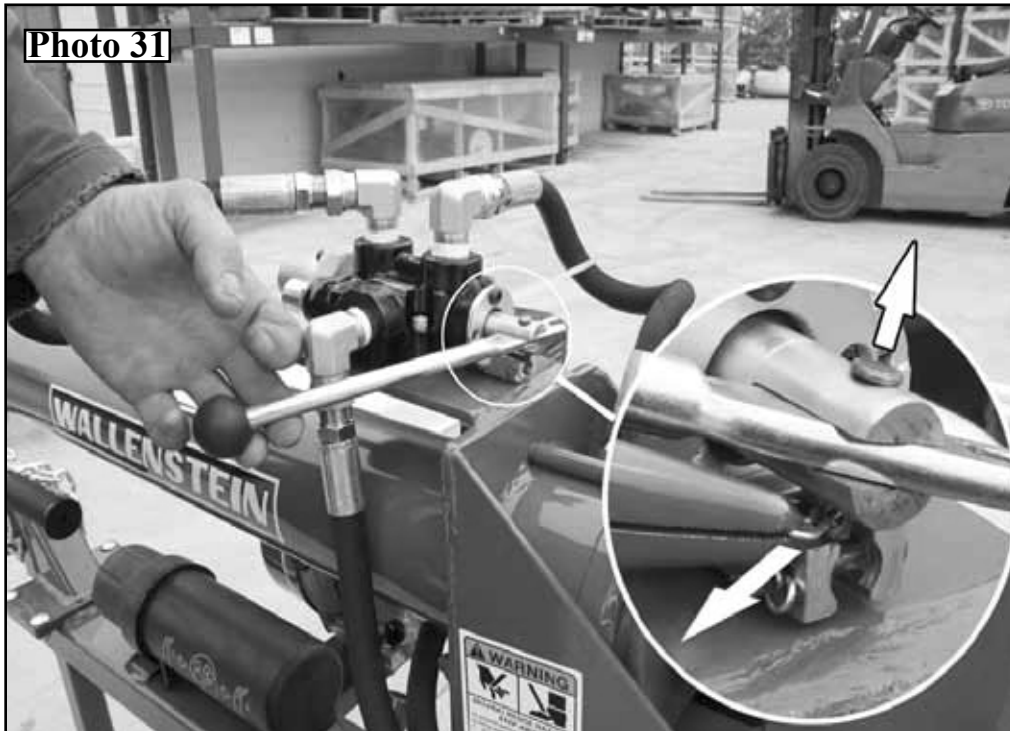

28. Re-install Handle in vertical position inserting bottom slotted end of lever into lower pin and aligning upper hole with one in shaft. **Photo 32** Re-install Pin and secure with Pin Clip. See **Photo Inset**.



29. Completed assembled Wood Splitter. *Photo 33*

