

WALLENSTEIN

TM

Operator's Manual

Keep this manual with the machine at all times

SG325D

Stump Grinder

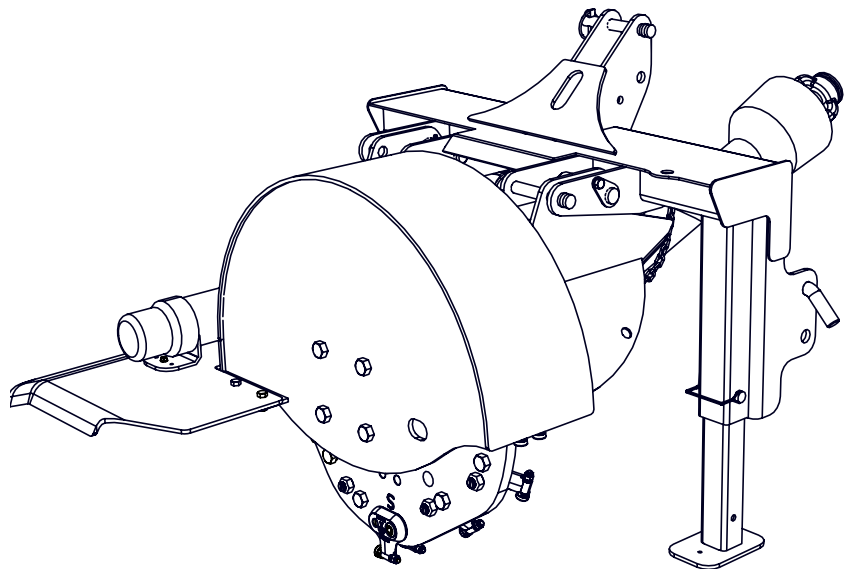

**CAUTION
Operational Hazard**

Dig safe - avoid underground utilities!
Always contact your local utility
companies (electrical, telephone, gas,
water, sewer, and others) before digging



**CAUTION
Operational Hazard**

Personal Protection Equipment
(PPE) is required when operating
or maintaining this machine.



Do not attempt to operate the equipment without thoroughly
reviewing this manual for safe and proper operation.

TABLE OF CONTENTS

Introduction	3	Field Operation	20
OPERATOR ORIENTATION	3	Operation Safety Checklist	20
General Information	4	Prepare	20
Intended Use	4	Mount the Stump Grinder	21
California Proposition 65	4	Operating the Stump Grinder	22
Serial Number Location	4	SG325D User Tips	23
Safety	5	Storage	24
Safety Messages	5	Storage Safety Checklist	24
Accident Prevention	6	Prepare for Storage:	24
Safety Guidelines	7	Placing in Storage:	24
Safety Training	7	Service and Maintenance	25
Preparation	8	Maintenance Safety Checklist	25
Wood Dust Hazard	8	General Maintenance	25
Storage Safety	8	Lubrication	26
Operation Safety	8	Cutting wheel	27
Maintenance Safety	9	Inspect Cutting Teeth	27
Safe Work Area	9	Indexing Cutting Teeth	27
Transport Safety	9	Replacing Cutting Teeth	28
PTO Drive-line Safety	10	Replacing Tooth Pockets	28
Safety Labels	11	Drive-line	29
Safety Label Descriptions	11	PTO Drive-line Clutch	29
If labels need to be replaced:	11	PTO Drive-line Clutch Spring Height	30
Safety Label Layout	12	Bolt Torque Table	31
Specifications and Dimensions	13	Troubleshooting	32
Specifications	13	Accessories	34
Dimensions	13	#132369 Hitch Extension Kit	34
Inspection	13	# DS510 Debris Screen	34
Components and Features	14	WARRANTY	35
Initial Setup	15		
HDPE Deflector Install	15		
Prepare the Quick Hitch	15		
Extension Kit	16		
Extension Assembly and Installation	16		
Sizing PTO Drive-line	17		
Prepare the Drive-Line	18		
PTO Drive-line Clutch Preparation	18		
PTO Test Installation	19		

INTRODUCTION

Congratulations on your choice of a Wallenstein **SG325D Stump Grinder** to complement your stump grinding operation. This equipment has been designed and manufactured to efficiently grind tree stumps.

Model SG325D features 18 teeth on a 25 in. cutting wheel, resulting in longer tooth life and smoother cutting for less wear on the tractor. Heavy tooth population means less cutting per tooth and makes finer mulch and smoother operation.

The cutting wheel is powered by the 540 RPM (max) PTO on your tractor supported by a CAT I three-point hitch. Grease fittings are provided at major pivot points for extended service life. The high-density polyethylene (HDPE) debris shield is standard equipment on all stump grinders. It is recommended that the stump grinder never be operated without one.

Safe, efficient and trouble free operation of your stump grinder requires that you and anyone else who will be operating or maintaining the stump grinder, read and understand the Safety, Operation, Maintenance and Troubleshooting information contained within the Operator's Manual.

Use the Table of Contents as a guide to locate required information. Keep this manual handy for frequent reference and to pass on to new operators or owners. Call your local dealer, distributor, or Wallenstein Equipment if you need assistance, information or additional copies of the manuals.

When this machine is worn out and no longer in use, it should be taken to an appropriate recycling facility.

This manual covers models: **SG325D Stump Grinder**.

OPERATOR ORIENTATION

The directions left, right, front, and rear, as mentioned throughout this manual, are as seen from the tractor driver's seat and facing in the direction of forward travel, unless noted otherwise.

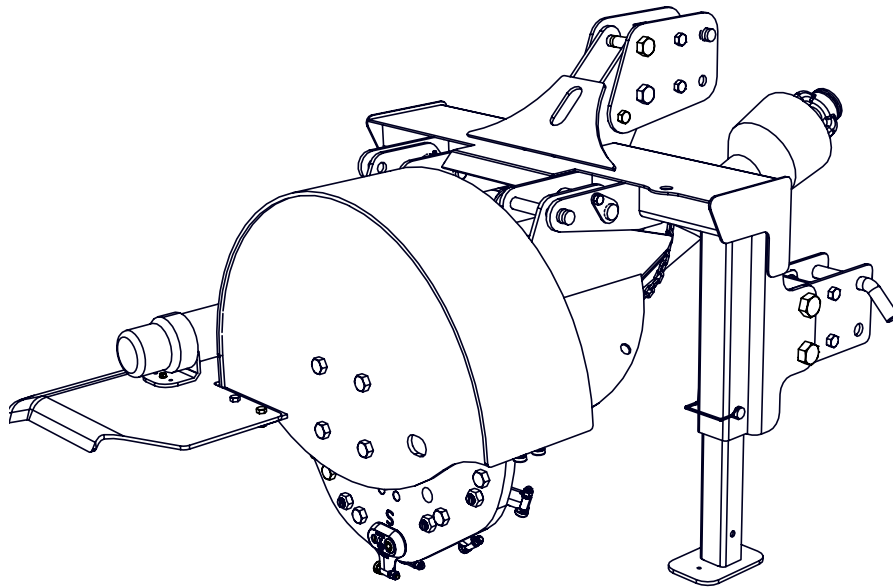

SG325D shown with hitch extensions

GENERAL INFORMATION

The purpose of this manual is to assist you in safely operating and maintaining your **SG325D Stump Grinder** in a safe manner. Read this manual carefully to obtain valuable information and instructions that will help you achieve safe and dependable service.

The stump grinding tool is designed to be used by experienced operators, trained in the safe operation of a tractor and trained in the hazards related to using the stump grinder and the safe use of the grinder for the intended purpose. Operators will require personal protective equipment to reduce the risk from some hazards that cannot be completely eliminated or controlled by the design of the tool.

The **SG325D** is intended to be used within the stump size limits shown in the specifications on the website and in this manual. Care is required to ensure that the stump grinding tool will not come across metallic objects, stones or other materials while grinding.

The **SG325D** is not designed for use in hazardous atmospheres where there is a risk of fire or explosion due to flammable gases or vapors. Use in hazardous, explosive atmospheres is prohibited. Serious injury or death of the operator or bystanders may be caused if the tool is misused. Misuse may also cause damage to the tractor carrying the implement.

The illustrations and data used in this manual were current at the time of printing, but due to possible engineering and or production changes, this product may vary slightly in detail. Wallenstein Equipment reserves the right to update and or change components as necessary without notification.

In this manual the **SG325D** may be referred to as grinder, stump grinder, machine, implement or attachment.

Tractor refers to any power unit attached to a SG325D.

INTENDED USE

The **SG325D Stump Grinder Direct Drive** is intended for rear mount three point hitch attachment and use on qualified power units for the sole purpose of grinding tree stumps within the specifications listed in this manual.

CALIFORNIA PROPOSITION 65

You may see a warning label like the following:

This warning is required by California Proposition 65 (Prop 65), which is meant to notify California residents of exposures to Prop 65-listed chemicals. For more information go to www.P65Warnings.ca.gov.



SERIAL NUMBER LOCATION

The serial number for your **SG325D** is located on the left side inside the support frame.

Please record your serial number here for reference. In case of warranty issues, you will need the serial number of your machine to verify your warranty.

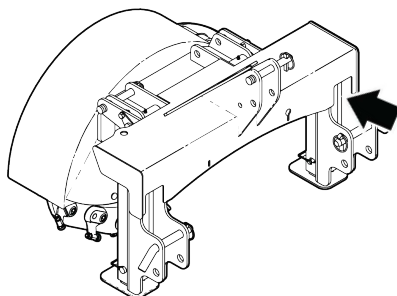

Model Number _____

Serial Number _____

SAFETY



This Safety Alert Symbol means:
ATTENTION!
BECOME ALERT!
YOUR SAFETY IS INVOLVED!

The Safety Alert symbol identifies important safety messages on the implement and in the manual. When you see this symbol, read and understand the message, be alert to the potential hazard in the message. Follow the instructions in the safety message.

SAFETY MESSAGES

Throughout this manual, the terms **DANGER**, **WARNING**, **CAUTION** and **IMPORTANT** are used to indicate the degree of hazard to personnel if proper safety procedures and guidelines are not followed. The appropriate term for each message has been selected using the following guide-lines:

DANGER - Indicates an imminently hazardous situation that, if not avoided, will result in death or serious injury, and includes most extreme situations typically for implement components which, for functional purposes, cannot be guarded.

WARNING - Indicates a potentially hazardous situation that, if not avoided, could result in death or serious injury, and includes hazards that are exposed when guards are removed. It may also be used to alert against unsafe practices.

CAUTION - Indicates a potentially hazardous situation that, if not avoided, may result in minor or moderate injury. It may also be used to alert against unsafe practices.

IMPORTANT - Indicates a situation that could result in damage to the implement or other property.

In the owners manual, when a hazard is present you will see a safety message box. The box may contain:

- The safety alert symbol,
- The safety term
- The safety hazard
- The safety hazard explanation

When applicable you may also see the appropriate safety label displayed with the message, as shown below.

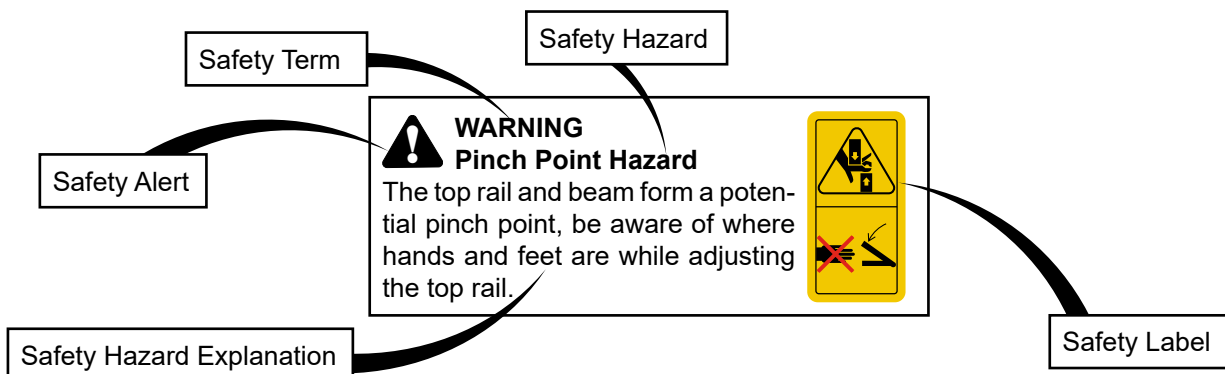

The safety information given in this manual does not replace any safety codes, insurance needs, government and local laws.

ACCIDENT PREVENTION

ACCIDENTS CAN BE PREVENTED WITH YOUR HELP!

YOU are responsible for the SAFE operation and maintenance of your implement. **YOU** must ensure that you and anyone else who is going to use, maintain or work around the implement be familiar with the work and maintenance procedures and related SAFETY information contained in this manual. This manual will take you step-by-step through your working day and alerts you to all good safety practices that should be used.

Remember, **YOU** are the key to safety. Good safety practices not only protect you but also the people around you. Make these practices an effective part of your day to day work habits. Be certain that EVERYONE using this implement is familiar with the recommended maintenance and work procedures and follow all the safety precautions. Most accidents can be prevented. Do not risk injury or death by ignoring good safety practices.



The best accident prevention is a careful operator.

Wallenstein asks that YOU be that careful, responsible equipment operator.

YOU ARE THE KEY TO SAFETY:



• Familiarize yourself, and anyone else who will operate, maintain, or work around this product, with the safety and operation information contained in this manual.

- Read and understand the safety labeling which appears on the implement.
- Have a first-aid kit available for use should the need arise and know how to use it. 
- Pay attention to the job at hand. Do not let your mind lose concentration on what you are doing. No accident prevention program can be successful without the wholehearted cooperation of the person who is directly responsible for the operation of the implement.
- Have a fire extinguisher available for use should the need arise and know how to use it. 
- Reduce the risk of injury or death by following all safety precautions and by using good safety practices.
- Accidents can be prevented: that prevention will come from equipment operators who accept their complete responsibility and anticipate the results of their actions.

- Never exceed the limits of the implement. Safety of the operator and safe operation are the main concerns in designing a safe product, however ignoring implement specifications by the operator can result in a accident which could have been prevented.



- Do not allow riders on the implement, loaded or empty.
- Do not operate this implement under the influence of drugs or alcohol.
- Be responsible for the SAFE operation and MAINTENANCE of YOUR implement.
- Wear appropriate personal protective equipment (PPE). This list includes but is not limited to:

- Hard hat
- Heavy gloves
- Hearing Protection
- Protective foot wear
- Protective eye wear
- Safety Vest
- Dust Mask



SAFETY GUIDELINES

Safety of the operator and bystanders is one of the chief concerns in developing and designing equipment. However, every year many accidents occur which could have been avoided by a few seconds of thought and a more cautious approach to handling equipment.

You, the operator, can avoid many accidents by observing the following precautions in this section. To avoid personal injury or death, study the following precautions and insist those working with you, or for you to follow them.

In addition to the design and configuration of this implement, including safety labels and safety devices, hazard control and accident prevention are dependent upon the awareness, concern, and proper training of personnel involved in the operation, transport, maintenance, and storage of the implement. Refer also to safety messages and operation instruction in each of the appropriate sections of the tractor and implement manuals. Pay close attention to the safety labeling affixed to the implement.

1. In order to provide a better view, certain illustrations in this manual may show an assembly with a safety device removed. However, equipment should never be used in this condition. Keep all safety devices in place, if removal becomes necessary for repairs, replace the device prior to use.
2. Replace any safety label or instruction sign that is unreadable or is missing. Location of safety signs is indicated in this manual.
3. Never use alcoholic beverages or drugs which can hinder alertness or coordination while using this implement. Consult your doctor about using this implement while taking prescription medications.
4. Under no circumstances should young children be allowed to work with this implement.
5. This implement is dangerous to persons unfamiliar with its operation. Do not allow persons to use or assemble this unit until they have read this manual and have developed a thorough understanding of the safety precautions and of how it works. Review the safety instructions with all users annually.
6. If the elderly are assisting with work, their physical limitations need to be recognized and accommodated. Assistants should be a responsible, properly trained and physically able person familiar with machinery and trained in this implement's operations.
7. Never exceed the limits of the implement. If its ability to do a job, or to do so safely, is in question - DON'T TRY IT.
8. Do not modify the implement in any way. Unauthorized modification may result in serious injury or death and may impair the function and life of the implement.

SAFETY TRAINING

A person who has not been trained or has not read and understood all use and safety instructions is not qualified to use the implement. An untrained operator exposes himself and bystanders to possible serious injury or death.

- Train all new personnel with the instructions alongside the implement. Be certain only a properly trained and physically able person will use the machinery.
- Working with unfamiliar equipment can result in injuries. If this machine is used by any person other than yourself, or is loaned or rented, it is the owner's responsibility to make sure that the operator, before using the machine:
 - Reads and understands the operator's manuals.
 - Is instructed in safe and correct use of the machine.
 - Is physically able to use the machine. Before operation, evaluate the physical and/or mental limitations of each operator to make sure that they can use the machine safely. Do not let a child operate the machine
- Operators or maintenance personnel who are not fully able to read and understand this manual should not operate or work on the implement:
- Make certain that all operators and maintenance personnel have complete understanding of the full and exact contents of this manual and safety labeling.
- ALL information contained in this manual and labeling on the implement must be conveyed CLEARLY and FULLY, in order to be able to operate safely and knowledgeably.
- Review the implement and instructions regularly with existing workers.

PREPARATION

1. Dig safe - avoid underground utilities! Always contact your local utility companies (electrical, telephone, gas, water, sewer, and others) before digging so that they may mark the location of any underground services in the area. Be sure to ask how close work can be done to the marks they positioned.
2. Inspect the machine for shipping damage. If damage does exist, do not use the machine. Notify your dealer or Wallenstein Equipment immediately to have the damaged parts replaced or repaired.
3. Assembly may be required depending on how you purchased your equipment. Follow the assembly procedures as outlined in the manual, ensure all hardware is secure.
4. When traveling on a public road at 32 km/h (20mph) or less, ensure a rear facing slow-moving-vehicle (SMV) emblem has been installed.
5. Ensure safety chain, straps, tires are not damaged and in good condition.
6. Inspect all fasteners that they are not lose or missing. Ensure fasteners are torqued according to the torque chart at the back of this manual
7. If traveling at night, ensure provincial state and local laws concerning lighting requirements have been met.
8. Ensure that all applicable safety decals are installed and legible.
9. Personal protection equipment (PPE) including hard hat, safety glasses, safety shoes, dust mask, and gloves are recommended during assembly, installation, operation, adjustment, maintaining, repairing, removal, cleaning, or moving the unit. Do not allow long hair, loose fitting clothing or jewelry to be around equipment.
10. **PROLONGED EXPOSURE TO LOUD NOISE MAY CAUSE PERMANENT HEARING LOSS!**
Gas or diesel powered equipment can often be noisy enough to cause permanent, partial hearing loss. We recommend that you wear hearing protection on a full-time basis. Noise over 85dB on a long-term basis can cause severe hearing loss. Noise over 90db adjacent to the Operator over a long-term basis may cause permanent, total hearing loss.
11. When not attached to the tractor support the implement to prevent movement.

WOOD DUST HAZARD

Avoid Wood Dust Inhalation: Exposure to wood dust has been associated with health issues due to the natural chemicals in wood or substances in the wood, such as bacteria, molds, or fungi.

Wood dust is considered carcinogenic to humans (Group 1) according to the International Agency for Research on Cancer (IARC).

Wood dust is also associated with toxic effects, irritation of the eyes, nose and throat, dermatitis, and respiratory system effects which include decreased lung capacity and allergic reactions.

Wood Dust is Flammable: wood dust can cause a fire or explosion if the particles are the right size and in the right concentration. Work only in well ventilated areas away from sources of ignition.

STORAGE SAFETY

1. Store the unit in an area away from human activity.
2. Do not allow children to play on or around the stored implement.
3. Store the unit in a dry, level area. Cover if stored outside.
4. Guard any sharp corners.
5. Ensure components and safety features are not damaged and in good condition before storing the implement. Make repairs now to be ready for the following season.
6. Secure the implement to prevent unwanted movement.

OPERATION SAFETY

1. NEVER allow helpers or bystanders under or near the machine.
2. Make sure that the machine is fastened securely to the power unit before moving.
3. Inspect all fastening devices, do not use if worn or damaged.
4. Make sure that everyone is clear before moving the implement. NEVER position yourself between the tractor and the implement.
5. Do not permit riders while transporting this implement.
6. Where possible, avoid operating near ditches, embankments and holes.
7. Slopes are a major factor related to loss of control and tip-over accidents, which can result in severe injury or death. Operating the machine on any slope or uneven terrain requires extra caution.

MAINTENANCE SAFETY

1. Good maintenance is your responsibility, follow the maintenance schedule. Poor maintenance is an invitation to trouble.
2. Follow good shop practices.
 - Keep service area clean and dry.
 - Be sure electrical outlets and tools are properly grounded.
 - Use adequate light for the job at hand.
3. Never work under or around the implement unless it is blocked securely.
4. Use personal protection equipment (PPE) such as eye, hand and hearing protectors.
5. Never adjust, service, clean or lubricate the implement until all power is shut off when attached to the power unit.
6. Ensure hardware is torqued according to the torque chart at the back of this manual.
7. Disconnect battery ground cable before servicing any part of the electrical system.

SAFE WORK AREA

Not all work spaces are the same, but the principles presented here can be applied to any work space.

Survey the work site, remove debris and make note of nearby or overhead obstructions, knowing your work area will make the clearing job easier and safer.

Where possible, avoid operating near ditches, embankments and holes.

For worker safety a prework site visit is recommended. Make a plan to identify hidden obstacles, structures and debris areas. Sudden impact from obstacles hidden under the surface may cause injury.

Be aware of:

Bystanders or any one not directly involved with the work are only allowed outside of the work area, minimized hazards.

Workers helping the operator must wear the appropriate PPE and must always make eye contact with the operator before entering the work area. Unauthorized Workers or bystanders are not allowed in the work area. Hazards are present.

Operator, do not operate the implement outside of the operator area.

TRANSPORT SAFETY

1. Check power unit tires before proceeding:
 - Inflation - correct pressure
 - Tread - unusual wear, exposed cord
 - Rims - damaged or bent
 - Wheel bolts - all secure, not loose
 - Replacement tires must be same type and rating
2. Just before transport, perform a circle check to ensure everything is safe.
3. Be sure all markers required by local traffic regulations are in place, clean and working. SMV: required if traveling at 32 km/h (20 mile/h) or less on a public road.
4. If traveling at night, ensure provincial state and local laws concerning lighting requirements have been met. Lighting is not required for daytime transport, however generally lighting is required one-half hour before sunset to one-half hour after sunrise and at any other time when there is insufficient light or unfavourable atmospheric conditions.
5. Reduce speed when turning, crossing slopes and rough, slick or muddy surfaces.
6. Stopping distance increase with speed, weight and on slopes.

PTO DRIVE-LINE SAFETY

1. Review and understand safety labeling on the PTO drive-line.
2. Be aware that the slip clutch end of the PTO may be very hot and could cause burns, use caution when working around the slip clutch.
3. Ensure the drive-line has been properly sized to accommodate the particular hitch and tractor combination.
4. Keep the guard tubes overlapped as much as possible during transport and operation or rotation.
5. Ensure that the profile tubes are not overextended. Under all working conditions, extension of the drive-line should not exceed the reported values in this manual. All rotating parts must be guarded.
6. Do not exceed the values given in this manual for permissible length extension. If greater telescoping ability is required, use a larger sized PTO drive-line.
7. Ensure that all drive-line and tractor shields are functional and in place before operation. Damaged or missing parts must be replaced with the original equipment spare parts and correctly installed, before using the drive-line.
8. All rotating parts must be guarded, contact with an unshielded rotating drive-line can cause death or serious injury.
9. Ensure the drive-line shield restraint chain is attached to the tractor master shield to prevent the shield from rotating.
10. Check that the drive-line restraint chain is trimmed to the correct length so as not to wrap around the drive-line shield.
11. Never use the restraint chain to support the PTO drive-line when not in use, the PTO shield could become damaged and will not perform as required.
12. To protect the PTO from damage or contamination, always use the PTO drive-line support when the unit is not in use.
13. Disengage the PTO, turn off the tractor engine, remove and pocket the key, and check that all rotating parts have come to a standstill before approaching the implement or performing maintenance work.
14. Tie back long hair and do not wear loose clothing, jewelry or anything which could get caught in the machines rotating parts.
15. Do not stand, lean, or otherwise come in contact with the drive-line. Do not step over or go under the drive-line.
16. Always connect tractor PTO to STATIONARY MACHINERY. Chock the tractor wheels to prevent rolling and check that joint angles are small and as equal as possible.
17. Do not approach, nor allow bystanders to approach the work area or rotating parts and drive-line.
18. Ensure drive line is rotating in the correct direction, as indicated in this manual.

SAFETY LABELS

Safety labeling is an important part of the overall safe use of the implement. Safety labeling alerts and warns against potential injury or death, and is important to follow these points to help keep your implement safe for you and others who may be using it.

- Keep safety signs clean and legible at all times.
- Replace safety signs that are missing or have become illegible.
- Replaced parts that displayed a safety sign should also display the current sign.
- Safety signs are available from your local dealer, distributor, or Wallenstein Equipment.

SAFETY LABEL DESCRIPTIONS



Caution: read and understand ALL safety and operating instructions in the manual, read and understand ALL safety labels located on the machine. The most important safety device on this equipment is an informed SAFE operator.



Warning: When attaching the spreader 3PH, to the power unit, stay clear of lower hitch arms lifting range while adjusting the 3 PH. Possible crushing, amputation or death.



Caution: when repairing or maintaining the unit ensure power unit is off and the key is removed and pocketed. Possible entanglement and amputation hazard.



Caution: Moving parts present a potential pinch hazard and could result in a serious injury. Use caution and be aware of parts as they are being moved or adjusted. Possible crushing and amputation hazard.



Caution: Personal Protection Equipment (PPE) is required when operating or maintaining this machine. Failure to wear PPE will result in personal injury.



Caution: grinder blade causes flying material. Use caution and never grind toward people, buildings, vehicles or other objects. Possible laceration, bruises or impalement.



Caution: do not place your hand or any part of your body on or near the grinder wheel while the machine is in operation. Rotating parts are in motion and serious injury could result. Possible entanglement, amputation or death.



Warning: Do not operate machine without PTO safety shields in place. Entanglement danger present, keep hands, loose clothing, and long hair away from spinning PTO. Possible entanglement, amputation or death.



Important: Be certain your tractor's PTO output is set-up to operate at 540 rpm. Do not exceed 540 rpm power take-off speed, injury or equipment breakage may result. Label indicates rotation as viewed from the label position.

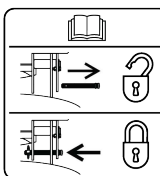

Notice Label: This label indicates the use of the lock pin and refer to the manual for details.

Lock pin must be removed during operation to allow the rotor head to pivot.

Lock pin must be in place whenever the grinder is in storage or being transported to keep the rotor head in place.

IF LABELS NEED TO BE REPLACED

- Be sure that the installation area is clean and dry.
- Be sure temperature is above 50°F (10°C).
- Determine exact position before you remove the backing paper.
- Remove the smallest portion of the split backing paper.
- Align the sign over the specified area and carefully press the small portion with the exposed sticky backing in place.
- Slowly peel back the remaining paper and carefully smooth the remaining portion of the sign in place.
- Small air pockets can be pierced with a pin and smoothed out using the piece of sign backing paper.

SAFETY LABEL LAYOUT

Safety signs and locations on the equipment are shown in the illustrations below. .

Good safety practice requires that you familiarize yourself with the label and the safety message it is delivering. Be aware of the equipment or particular equipment feature that requires your SAFETY AWARENESS.

If safety labels have been damaged or removed, new labels must be applied. New safety signs are available from your dealer or Wallenstein Equipment.

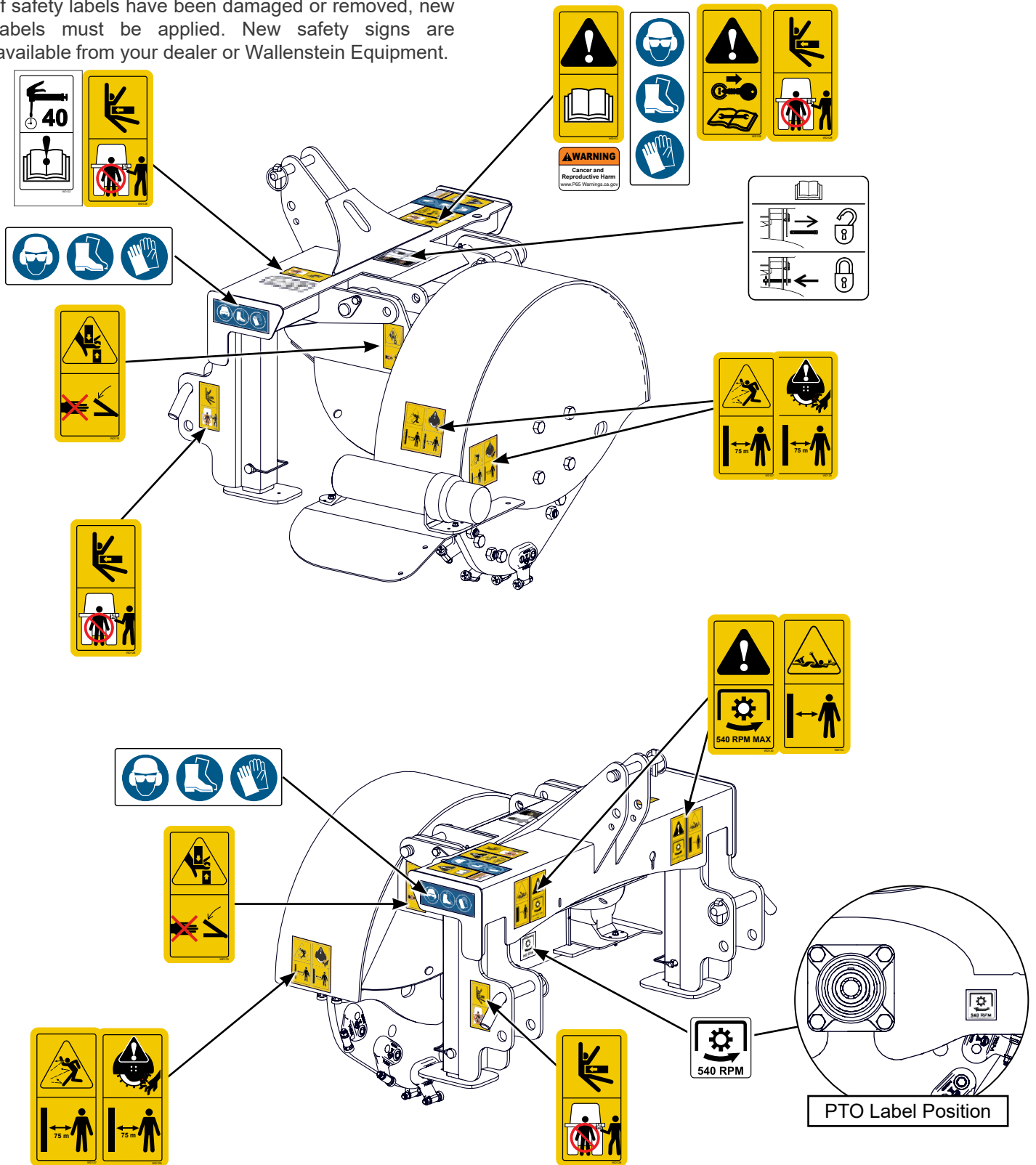

SPECIFICATIONS AND DIMENSIONS

SPECIFICATIONS

SG325D Stump Grinder	
Recommended PTO HP	20-45 HP
PTO (input speed)	540 RPM Max
Rotor Size	25"
Tooth Construction	Replaceable Three Sided Carbide Bolt into Pocket
Number of teeth	18
Cutting Wheel rotation	Clockwise Rotation (standing behind the tractor looking forward)
Cutting Wheel Speed (direct drive)	540 RPM
Cutting Height (above grade)	10"
Cutting Height (below grade)	7"
Cutting Depth (per pass)	2.25"
Cutting Width (per pass)	22"
Drive Line Protection	PTO Slip Clutch
Hitch	Rear Mount 3PH CAT I
Quick Hitch Compatible	Yes
Weight (shipping)	460 LBS.
Length	37.5"
Width	45"
Height	33.25"

DIMENSIONS

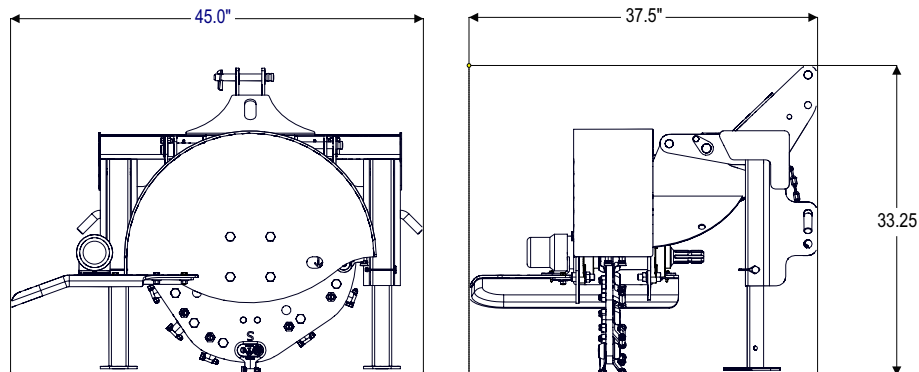

INSPECTION

After receiving your machine, inspect the machine for damaged or loose parts. If damaged or loose parts exist, do not use the machine. Notify your dealer or Wallenstein Equipment immediately to have the affected parts replaced or repaired.

COMPONENTS AND FEATURES

The Wallenstein **SG325D Stump Grinder** is designed and manufactured to efficiently grind tree stumps.

The owner or operator is responsible for being familiar with all the features of the SG325D and know how to operate it. Each owner or operator must train all other operators before they start working with the machine.

Read this section carefully to learn how to use the SG325D safely and how to set it to provide maximum field efficiency. By following instructions in conjunction with a good maintenance program, your SG325D will provide many years of trouble-free service.

Do not operate this machine if you are not familiar with its features.

The SG325D is illustrated below, showing its basic components and features. Review the various components and their position, the names of the components will be used to describe where they are and how they work through out the manual.

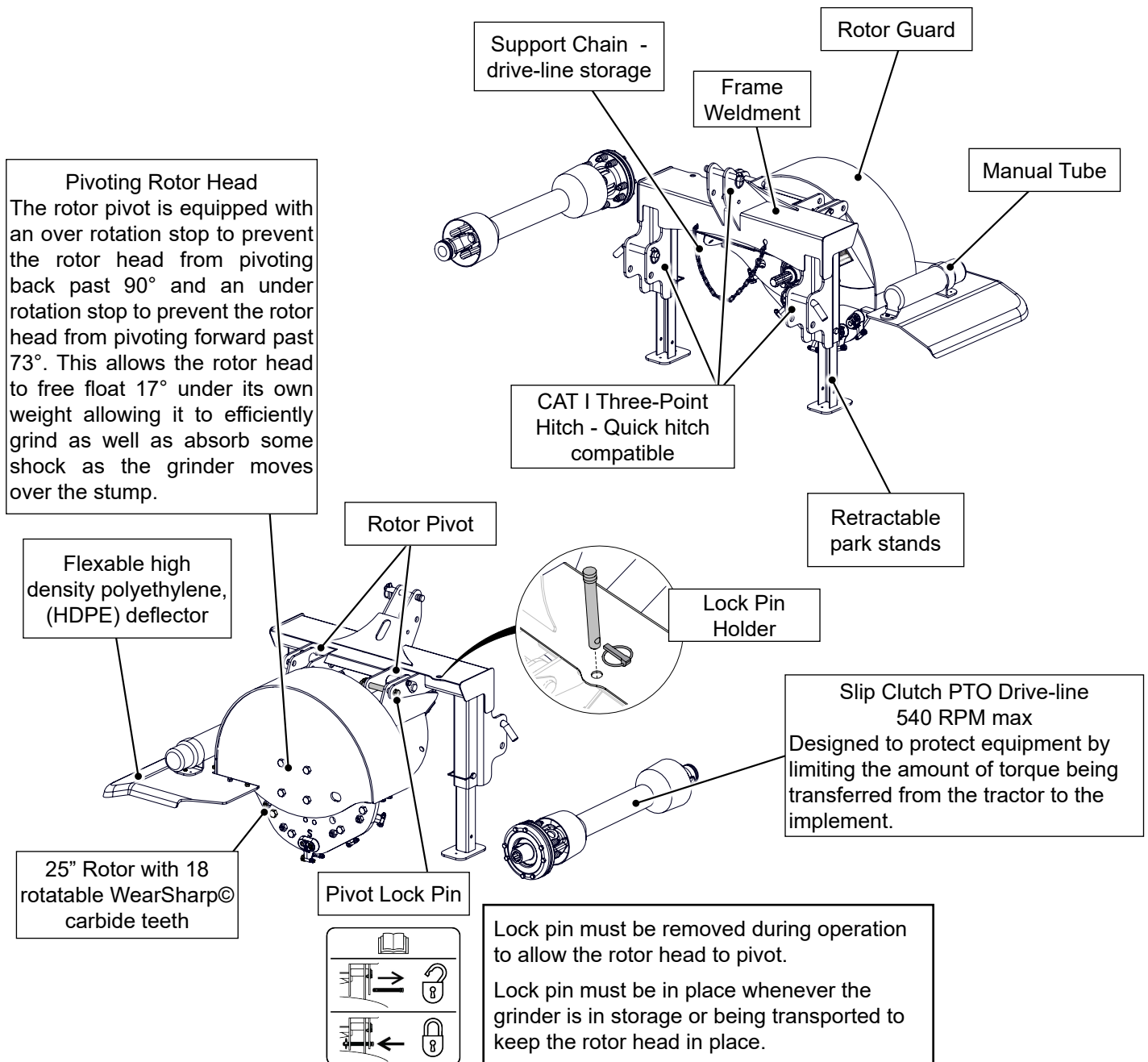

INITIAL SETUP

To prevent potential injury during installation and to ensure safe working conditions, avoid working around the tractor while it is running. Shut off the tractor and ensure the brakes are applied or the wheels have been secured with wheel chocks to prevent unwanted movement during the installation process.

Ensure you torque the bolts according to the torque chart in the back of this manual. This is a one time set up procedure, and will not have to be repeated.

The initial setup of the SG325D Stump Grinder assembly involves some basic steps.

- Install the HDPE deflector.
- Install the quick attach mount adaptor kit. (not included)
- Determine if extension kit is required and install. (not included)
- Sizing the PTO drive-line
- Preparing the drive-line slip clutch.

HDPE DEFLECTOR INSTALL

The SG325D Stump Grinder is shipped partially assembled. The high density polyethylene (HDPE) deflector is shipped not assembled and requires assembly to the main unit.

The deflector is shipped with the manual tube installed on the deflector, the illustration shows the manual tube removed for clarity of installation.

- Ensure the stump grinder sitting level and is secure from tipping.
- Remove the deflector mounting hardware from the deflector mount flange on the grinder.
- Fit the deflector on the mount flange of the grinder
- Install the 3/8 x 1.0 bolts, 3/8 lock-nuts and washers as shown in the diagram, and hand tighten.
- Torque hardware per torque chart in the back of this manual.

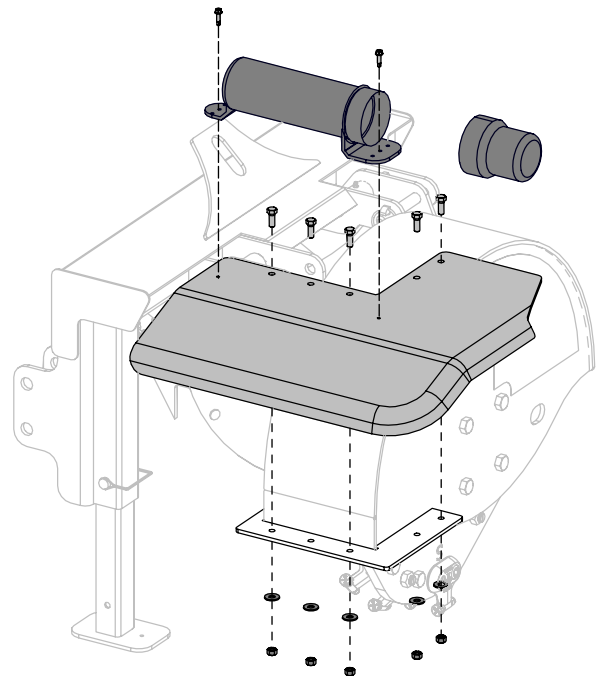

PREPARE THE QUICK HITCH

The SG325D Stump Grinder is CAT I quick hitch compatible. You can purchase and install a quick hitch system to make attachment easier.

Follow the instructions that came with your quick hitch system to assemble the quick hitch to the stump grinder. Test fit the assembly to the tractor. Test fitting ahead of time ensures a safe and secure attachment to the tractor with no surprises.

Check that all the pins and latches are in good condition and hold the stump grinder safely on the tractor.



WARNING Pinch Hazard

Keep hands away from mounting points while attaching to the power unit. Potential pinch hazard exist between the machine and power unit



EXTENSION KIT

In some cases the 3 point hitch geometry may be too short to safely accommodate the slip clutch drive-line supplied with the grinder. It is very important that the drive-line be free to telescope and not bottom out when going through its working range. If the drive-line is constantly bottomed out, the bearings on both the machine and tractor PTO drive-line will be overloaded and fail in a short time.

Extension bracket kit will add an additional 6.0" (153mm) to the space between the tractor output shaft and the grinder input shaft to facilitate the safe installation of the PTO drive-line.

To determine if an extension kit is required:

- On the tractor measure dimension (A) from PTO lock groove to center of lower link arm pin holes.
- If dimension (A) is less than 20 in. (508 mm), order #132369 Extension Bracket Kit.

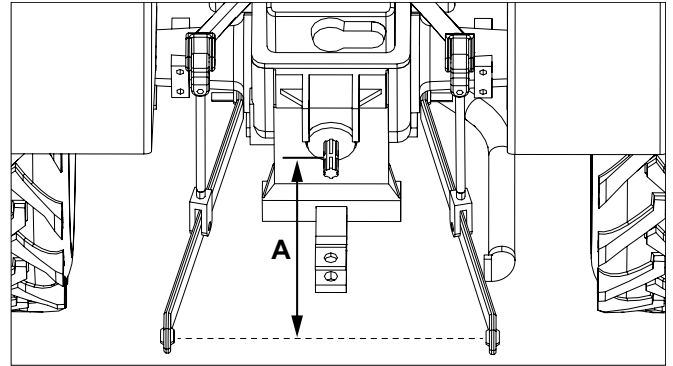

EXTENSION ASSEMBLY AND INSTALLATION

To prevent potential injury during installation and to ensure safe working conditions, ensure the grinder is on level ground and is secure to prevent unwanted movement during the installation process.

- Preassemble the top link extension: find the middle bracket and top link end plates.
- Bolt them together using the 3/8 x 1" bolts and lock nuts.
- Repeat the procedure for the two lower link assemblies.
- Fit the top link extension over the stump grinder top link (as shown in the diagram) and hand tighten with the 3/4 x 5" bolts and lock nuts.
- Fit the two lower link extensions inside of the flanges on the grinder lower links, (as shown in the diagram) and hand tighten with the 3/4 x 5" bolts and lock nuts.
- Torque all the bolts per torque chart in the back of this manual.

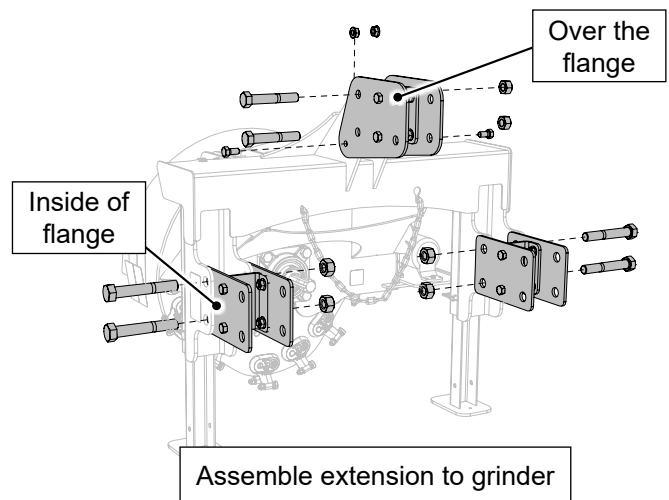
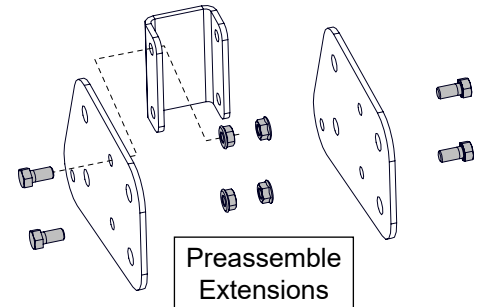

CAUTION

Heavy or bulky parts

Prevent potential strain injury, use approved lifting equipment or ask for help when lifting or moving heavy, bulky parts.



CAUTION

Operational Hazard

Personal Protection Equipment (PPE) is required while working in and around this machine.



SIZING PTO DRIVE-LINE

The PTO drive-line as supplied with the machine will need to be checked for the proper length before being put into service.

To accommodate the various hitch and tractor configurations the supplied length drive-line shaft may need to be shortened. The PTO drive-line must be free to telescope and not bottom out when going through its working range. It should never completely collapse in use and there should always be 2" of clearance to retract.

 If the drive-line bottoms out, the bearings on both ends can be overloaded and could fail causing damage or injury.

Follow these guidelines to ensure good fitment:

- Use a sharp hacksaw to cut the PTO tube.
- Use a fine file to remove any sharp edges and burrs from sawing.
- Clean off all dirt and filings from tube, carefully test for smooth fit.
- Apply a light coat of grease to the outside of the small tube.
- Cut the plastic shields slightly shorter to make assembly easier.
- Install the PTO drive-line with the slip clutch at the stump grinder input.

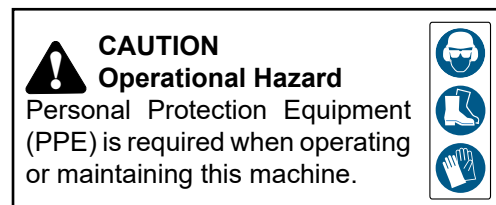

To determine the correct drive-line shaft length:

- Fully collapse the drive-line and measure the distance between the locking yokes: Dimension 'A'
- Raise or lower the equipment until the PTO output shaft of the tractor is horizontal with the input shaft on the machine.
- Measure lock-pin groove to lock-pin groove or bolt hole on the equipment to find the dimension 'B', and subtract 2.0" (for clearance).
'Length - 2.0" = B'
- Compare measurements: if the collapsed length 'A' is longer than dimension 'B', the PTO shaft must be shortened.
- Subtract 'B' from the uncut PTO shaft measurement 'A'.
- The result: dimension 'C' is how much BOTH halves of the PTO shaft need to be shortened.
'A - B = C'
- The difference of these measurements needs to be cut from **Both Halves** of the PTO shaft.
- Pull the PTO shaft apart, then measure and cut dimension 'C' from both the outer plastic covers and the inner metal tubes.
- Reassemble the drive-line.
- Install on equipment and check for fit and function, follow the procedure under 'Prepare the PTO'.

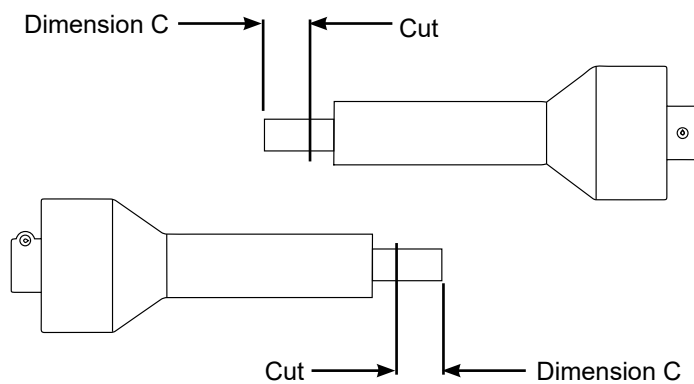
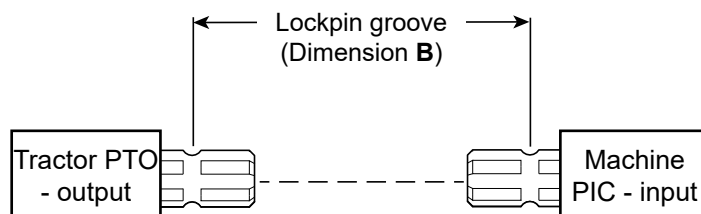
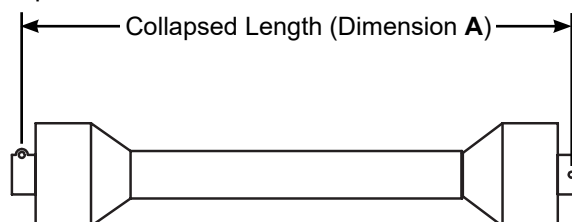

PREPARE THE DRIVE-LINE

PTO DRIVE-LINE CLUTCH PREPARATION

The slip clutch must be adjusted before first use or after a storage period. The clutch can become locked up over time or due to dirt, corrosion or condensation even if the implement is stored indoors.

Disengage tractor PTO, shut off engine and remove key. Have the stump grinder mounted and the drive-line not installed, and follow the steps below before using your stump grinder to ensure the PTO drive-line clutch plates are set properly.

! This procedure should be performed periodically as the clutch plates can stick together, particularly after periods of inactivity. Stuck plates prevent the clutch from slipping during operation as designed, resulting in high loads and possible damage to the steel shaft or tractor drive components.

- At the clutch end, using a marker, scribe a line across the exposed edges of the hub clutch plate and friction discs.
- Loosen each compression nut exactly two revolutions to free up the clutch friction discs.
- Install the drive-line.
- Start tractor and run drive-line at a low idle to slip the friction discs. This will remove any the dirt and corrosion from clutch plate faces.
- Disengage tractor PTO. Shut off engine and remove key.
- Inspect the clutch and ensure that the scribed markings on the disc and plates have changed position. If any two marks are still aligned, that is an indication that these discs have not slipped. Repeat steps 4-5.
- If any markings have not moved, disassembly may be required to free up the disks.
- After ensuring all discs are free, tighten the compression nuts uniformly in a star pattern, exactly two revolutions each to reset the clutch to original pressure. (see spring height diagram in maintenance for reference)
- The clutch should be checked during the first hour of use and periodically each week thereafter.
- Be aware of unusual clutch plate slippage, burning odor, or visible smoking, further adjustment may be required.

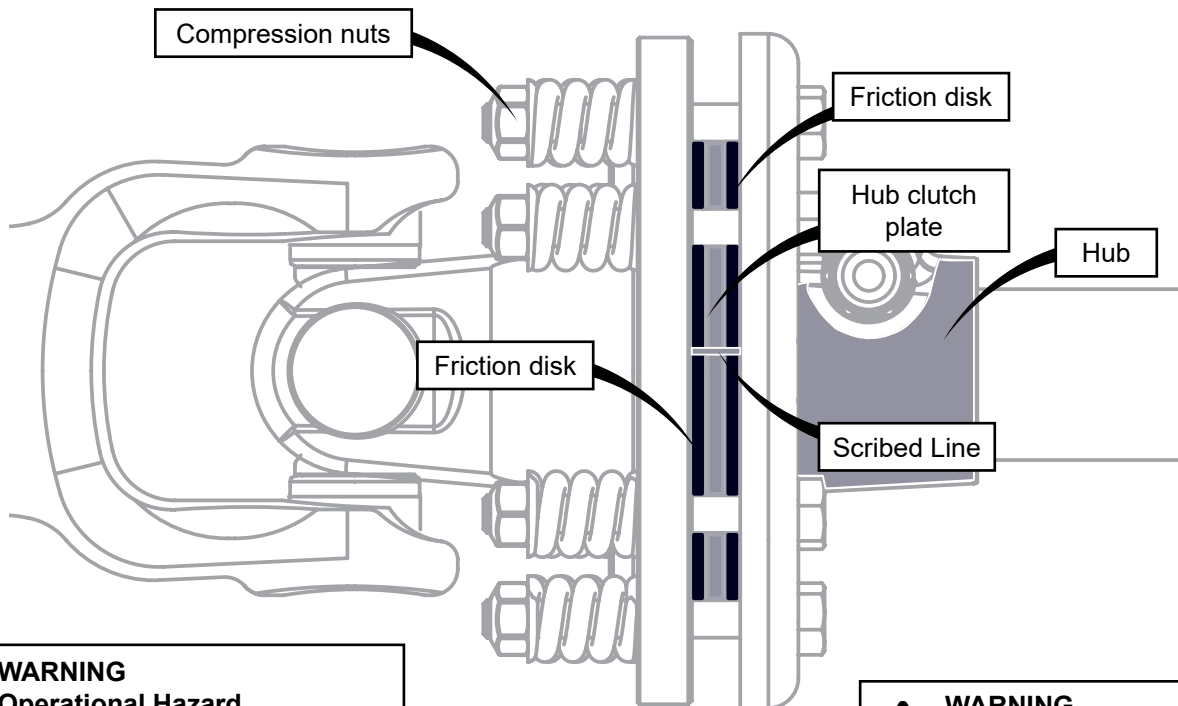

WARNING

Operational Hazard

The clutch should be checked periodically each week. Excessive clutch plate slippage, burning odour, or visible smoking should not be observed during use.



WARNING

Operational Hazard

To protect the PTO drive-line from damage or contamination, always use the PTO drive-line support when the unit is not in use

PTO TEST INSTALLATION

Before proceeding, see the 'Sizing PTO Drive-Line' section to ensure your drive-line is properly sized.

- Ensure the stump grinder is on a level surface, remove the pivot lock pin, and store in the pin holder.

 **Pivot lock pin must be removed for proper operation of the stump grinder.**

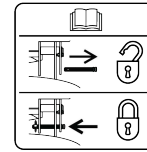

- Move the tractor up to the stump grinder and attach the tractor 3PH arms (or quick hitch if installed) to the stump grinder.
- Slowly lift the grinder until the input shaft is at the same height as the PTO output shaft on the tractor.
- Collapse the PTO drive-line completely, remove the taper lock pin and nut from the clutch end of the drive-line
- Apply multipurpose grease to the output shaft,
- Attach the drive-line to the tractor output, pushing the spring-loaded snap ring in and sliding the yoke onto the tractor spline until the ring snaps into place.
- Apply multipurpose grease to the grinder input shaft,
- Slide the clutch end of the drive-line to the grinder input shaft, assemble the taper pin to lock the drive-line in place.

 **If the drive-line cannot collapse far enough to slide it on the input and output shafts then the drive-line has to be shortened! (for more information see 'Sizing PTO Drive-line' page)**

- Make sure that the plastic shield is free to rotate on the PTO drive-line, and attach the shield restraint chain to the tractor PTO primary shield.

 **CAUTION
Operational Hazard**

Always connect the PTO guard restraint chain before operating the PTO. The restraint chain prevents the guard from rotating during normal operation. This prevents objects and operator clothing from becoming entangled.



Check that the drive-line restraint chain is trimmed to the correct length so as not to wrap around the drive-line shield.

- Lift and lower the 3PH arms to determine that the overlap on the PTO shaft is never less than 1/3 of the shaft length, if it is too short then the PTO drive-line will jam rather than collapse.

 **Jamming will put severe strain on the gearbox and PTO shaft. The PTO drive-line may separate, resulting in an uncontrolled wild spinning of the PTO shaft, causing severe injury or death!**

- Make sure PTO does not bottom out at any point when lifting or lowering the grinder. PTO shaft should not come within 2" of the yoke at any time.
- Raise the grinder off the ground, make sure any bystanders are well away from the machine.
- Adjust the top link so that the SG325D frame weldment is 90° (perpendicular) to the ground. Adjusting top link will help keep the drive-line at acceptable angle (17° or less) during operation.

 **WARNING
Operational Hazard**

Do not place your hand or any part of your body on or near the grinder wheel while the machine is in operation. Rotating sharp parts are in motion and serious injury could result.



 **Operating the PTO drive-line at angles greater than 17° can cause premature wear and damage to the drive-line.**

- Engage the PTO briefly and slowly start the grinder, to make sure that everything is turning freely and all pins are secure and guards in place.
- Disengage the PTO, shut down the tractor, wait for all moving parts to stop, then replace the pivot lock pin in the stump grinder.

 **CAUTION
Operational Hazard**

Tractor PTO must operate at 540 RPM only. Exceeding the grinders design speed of 540 RPM will result in operator injury or damage to the machine.



 **Pivot lock pin must be in place when not in use or transporting the stump grinder.**

FIELD OPERATION

This section describes how to safely and effectively operate the SG325D Stump Grinder in the field of operation. By following recommended procedures, a safe working environment is provided for the operator, bystanders and the area around the work site. Not all situations and conditions can be addressed, proceed with care and caution and use safety as your guide.

Lightweight power units may need weight added to the front or rear (depending on your configuration to maintain steering control and prevent forward / rear tipping or side tipping caused by a heavy load. Consult your power unit's Operator's Manual to determine proper weight requirements and maximum weight limitations. Stump grinder performance may vary due to material conditions and type and density of material. Ensure rotor rotation is correct: clockwise standing behind the tractor facing forward.

The owner or operator has the responsibility of being familiar with the operation of the SG325D and must train all other operators before they start working with the machine.

Wear appropriate breathing protection wood dust and if the work site contains silica, chemicals or other materials that become hazardous when airborne.

Work in a safe manner and follow all instructions exactly, safety is everyone's business. Untrained operators are not qualified to use the machine.

OPERATION SAFETY CHECKLIST

- | | |
|---|--|
| ✓ Avoid wearing loose clothing, scarves, jewelry or anything that may get caught in rotating parts. | ✓ Be aware of underground utilities! Ensure local utility companies have inspected and marked the location of any underground services in the area. Be sure to ask how close work can be done to the location marks. |
| ✓ Make sure that the machine is securely mounted before using. | ✓ Wear adequate safety gear, including dust mask, safety glasses with side shields, appropriate hearing protection and protective gloves. |
| ✓ Do not allow you or anyone to place hands or any body part on or near the machine while the machine is in operation | ✓ Do not operate a unit during or after the use of medication, drugs or alcohol. Safe operation requires your complete and unimpaired attention at all times. |
| ✓ Do not permit riders while using or transporting machine | ✓ Operate only when there is good visibility and light. |
| ✓ Do not allow bystanders near front or sides of the machine. Flying objects could be ejected at high speed. | |

PREPARE

- Clear the area of bystanders, especially small children.
- Training: each operator must be trained and familiar with the set up and operation of the product and its components.
- Review:
 - Components and Features.
 - Operation Safety Checklist.
 - Power unit safe operating instructions.
 - Connection procedures: PTO, 3PH attachment.
- Survey the work site, remove large debris and make note of nearby or overhead obstructions.
- The stump should be cut as close to ground level as possible
- Check PTO drive-line guards to make certain they are in good working condition and in place.
- Before use, inspect the machine (see service and maintenance section) and check the following:
 - Inspect your power unit, it must be in good operating condition (see power unit owner manual).
 - Check all cutting teeth, pins, nuts, bolts and screws and ensure they are all properly secured.
 - Ensure the rotor is spinning in the correct direction. (clockwise)
- It is recommended that each person wear appropriate Personal Protective Equipment (PPE). This list includes but is not limited to:
 - Dust mask appropriate for the material
 - Safety shoes with slip resistant soles.
 - Safety glasses.
 - Hearing protection.
 - Heavy or leather gloves.

MOUNT THE STUMP GRINDER

Ensure your attachment system is secure on the power unit. Mounting procedure will vary based on system used: 3PH, or the brand of quick hitch.

Verify there is sufficient visibility and maneuverability to move up to stump grinder. The stump grinder should be in position according to the power units mounting instructions. Verify pins are secure in the correct position.

- Support the drive-line and remove and stow the drive-line support chain
- Attach tractor's 3PH arms (or quick hitch) to the stump grinder: refer to the tractor operator's manual or quick hitch instructions.
- Remove the pivot lock pin, and store in the pin holder.

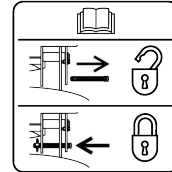

! Pivot lock pin must be removed for proper operation of the stump grinder.

- Raise the stump grinder off the ground slightly.
- Retract the park stands, and secure with snap pins
- Align the splines and push drive-line onto PTO output until it snaps securely into place, pull back on drive-line to make sure it is locked on tractor PTO shaft.
- Confirm the lock pin at the slip clutch is installed and secured to the stump grinder.
- Attach the PTO drive-line safety shield chain to the tractor master shield.

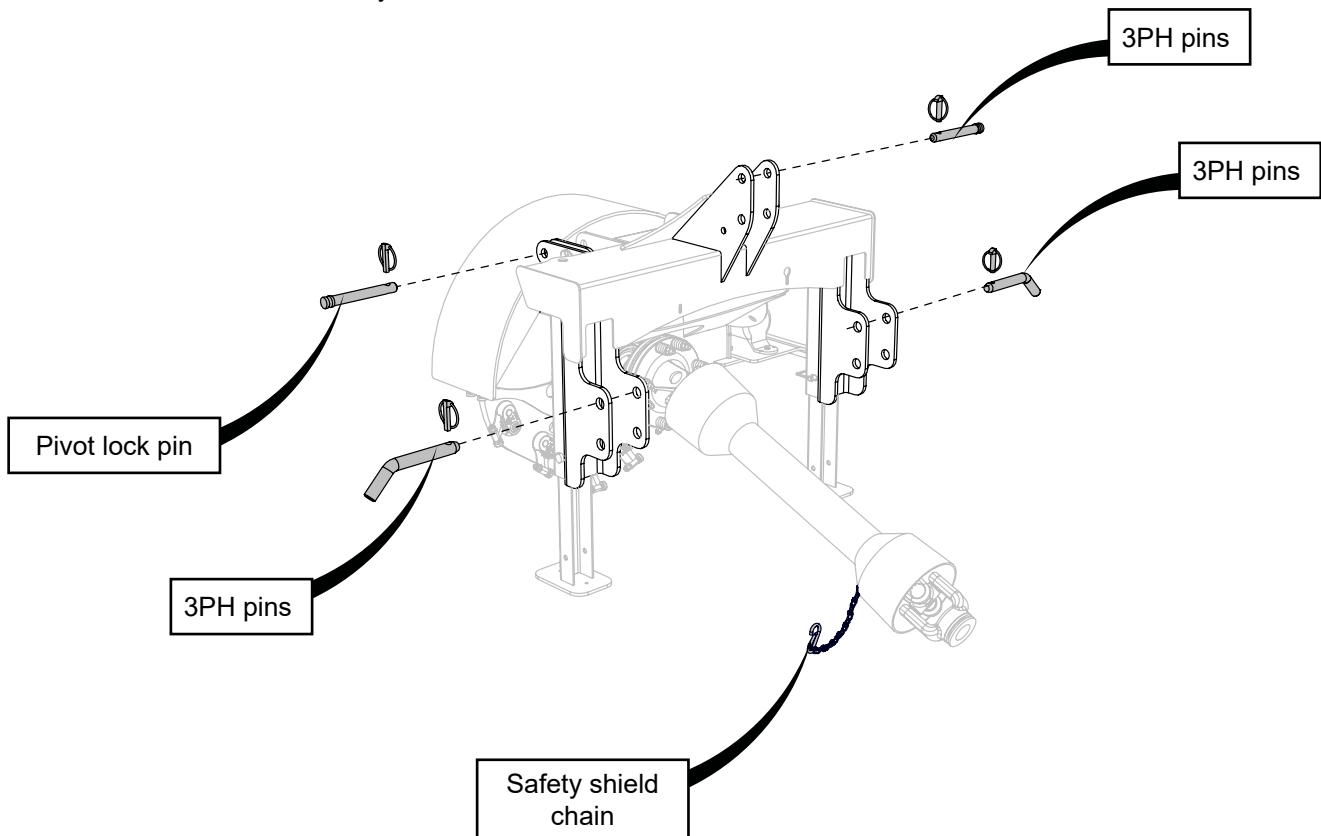

! **WARNING**
Pinch Hazard

Keep hands away from mounting points. Potential pinch hazard exist between the implement and power unit.



! **CAUTION**
Operational Hazard

Tractor PTO must operate at 540 RPM only. Exceeding the grinders design speed of 540 RPM will result in operator injury or damage to the machine.



OPERATING THE STUMP GRINDER

Ensure your PTO is off, all pins and safety shields are secured and pivot lock pin is removed. Inspect the work site and be aware of any underground utilities. Check the slip clutch is not locked up from inactivity. **(see maintenance: Drive-line)**

OPERATOR ORIENTATION - The directions left, right, front, and rear are referenced from the tractor driver's seat facing the direction of forward travel.

Stump grinding is always back to front across the stump with the rotor rotating clockwise into the stump, and the tractor moving in a forward direction. Always lower cutting wheel behind the stump, do not try cutting down, always cut moving the tractor forward across the stump.

When grinding softwoods the SG325D may be able to remove up to the maximum 2.25. in (57 mm) material per pass. However, hardwoods are more dense and the depth of grind may be much less. Adjust as required, the first pass will determine the optimum depth.

If the stump grinder begins to bounce or is vibrating heavily, it means either the tractor is advancing faster than the grinder can remove material or that too much material is being removed per pass. If this is the case, immediately stop forward motion and reposition the tractor and stump grinder and take a slower pass and/or shallower cut if necessary.

- Raise the Stump grinder to clear the stump,
- Orient the grinder so that the centre of the rotor is over the right edge of the stump.
- Back the tractor with the grinder up over the stump to the rear edge. (the edge that is farthest from the tractor), check the position of the stump grinder to the stump. This is your starting position.
- At idle engage the PTO, bring cutting wheel up to speed and slowly lower it in a controlled manner to the optimum grinding depth. Slowly move the tractor forward, cutting into the stump.
- After a complete pass move the tractor back over to the right, so that the centre of the rotor is over the new right cut edge, move back to starting position and lower cutting wheel to the optimum grinding depth for next pass.
- When done the first layer, continue passes from right to left until the ground level is reached.
- Grind down below ground surface up to 7.0 in. (178 mm) below the surface to where the stump roots branch out, be aware of hard objects in the dirt.

⚠ Keep a look out for hard foreign objects below grade. Rocks or buried metal can damage or break the teeth resulting in poor grinding performance.

Throttle down the tractor to an idle.

- Disengage tractor PTO.
- Replace the pivot lock pin, shut off engine and remove key.

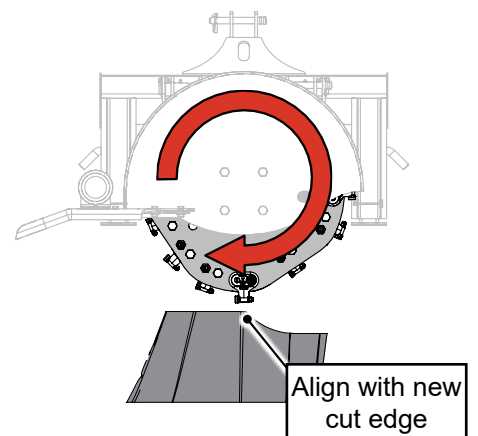
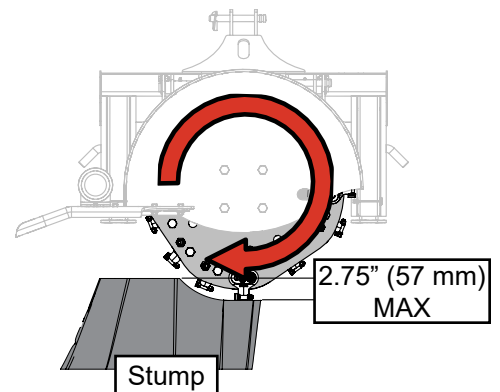
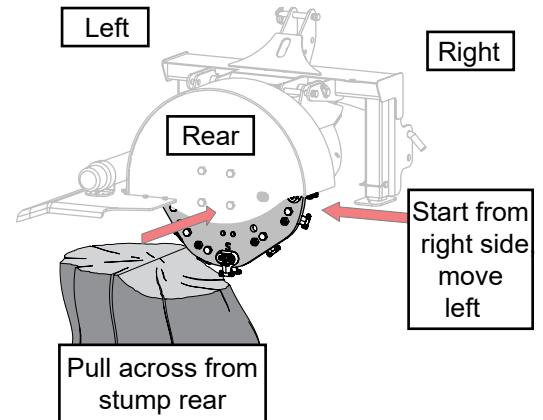

⚠ WARNING Operational Hazard

Do not place your hand or any part of your body on or near the grinder wheel while the machine is in operation. Rotating sharp parts are in motion and serious injury could result.



⚠ CAUTION Operational Hazard

Do not start at the left side or pull through the centre of a stump. This will induce severe vibration and cause the grinder to jump and bounce. It may also damage the machine and/or break teeth.

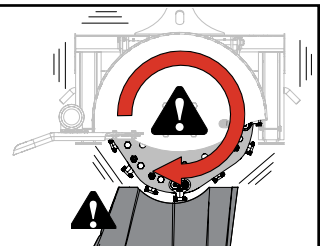

SG325D USER TIPS

- Before you begin, make sure the tractor is turned off and the PTO drive is disengaged and inspect the work site.
- Check that the area around the stump is free from stones and metal visible and concealed to prevent damage to the stump grinder.
- Familiarize yourself with the view of the stump grinder from the tractor seat.
 - Stand to the side of the stump grinder and observe the center point on the bottom of the cutting wheel.
 - Now sit on the tractor seat and observe the center point again.
 - Orient yourself with the rotor position from the operators seat.
 - Never attempt to operate the grinder when not in the operators seat on the tractor.
- The stump grinder should never be pulled through the centre of a stump or used from left-to-right. This will induce severe vibration and cause the grinder to bounce dangerously.
- Many variables, such as the type of tree, age, size, amount of moisture, and condition, affect the required amount of time and effort to grind a stump.
- Test all operating functions in an open area with the tractor at idle speed to get a feel for the controls.
 - Start with a small stump, and take your time. The cutting wheel is shielded from view when sitting on the tractor seat so it is difficult to accurately determine the progress.
 - Make the first pass, disengage the PTO drive and check the progress, exit the tractor to see how much you have removed.
 - Check progress after each pass.
 - The ability to judge the positioning improves with practice and experience.
- Operation should be smooth and grinding should be done gradually.
- In areas where debris from the stump grinder needs to be contained use a debris screen. A debris screen is available from your dealer or Wallenstein Equipment: **# DS510 Debris Screen 10'x5' (4 posts)**.
- If the stump grinder is jumping or bouncing off the stump, you are applying too much force. Applying too much force will shorten the life of the cutting teeth and may damage the stump grinder.
- If the stump is on a grade, position tractor lower on the grade with the cutting wheel on the stump grinder higher up the grade.
- All cutting is done on the front side of the rotor, not the bottom of the rotor. Always pull the rotor through a stump.
- Follow the root system, taking as much of the larger surface roots as possible. If these are not removed they can eventually protrude from the ground in areas where there is a heavy freeze/ thaw cycle.
- Never operate stump grinder when other people are in the vicinity.
- Always use full throttle (maximum engine speed), but do not exceed 540 rpm on the PTO.
- Check the condition of the grinding teeth before each job.
- Be sure to install the pivot lock pin anytime you are transporting the stump grinder.
- Be aware the slip clutch may require adjustment if not used for a period of time. See the maintenance section.
- Be prepared for machine “kickback” when initially contacting the stump.
- To help prevent accidental PTO drive-line separation or damage, the stump grinder is equipped with a over rotation stop to prevent the rotor head from pivoting up past 90° and a under rotation stop to prevent the rotor head from pivoting down past 74°.

STORAGE

STORAGE SAFETY CHECKLIST

- ✓ Store the implement away from work area's and livestock.
- ✓ Do not permit children to play on or around the stored machinery.
- ✓ Secure the implement to prevent unexpected movement.
- ✓ Ensure all pins, latches and locks are secure.
- ✓ Guard any sharp corners.

After the season's use or when the machine will not be used for a period of time, completely inspect all parts of the stump grinder. Replace or repair any worn or damaged components to prevent any unnecessary down time at the beginning of the next season. Your implement is an important investment. Spending some time to protect it from rust and corrosion will result a safer, longer service life and better performance..

PREPARE FOR STORAGE

1. Ensure the pivot lock pin is inserted in the left or right side of machine, and secured with a snap pin.
2. Thoroughly wash the machine with a pressure washer or water hose to remove all dirt, mud or debris.
3. Remove all remaining material and debris from the machine.
4. Inspect for damaged or worn parts. Repair or replace before next season.
5. Replace any missing or unreadable safety decals.
6. Repaint any chipped or scraped areas to prevent rust and corrosion.
7. Perform a maintenance on the grinder.

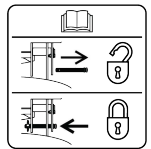

PLACING IN STORAGE

1. It is best to store the machine in a inside area. If that is not possible, cover with a waterproof tarpaulin and tie down securely.
2. Use a flat, level, dry and clean storage area.
3. Use the tractor to position the stump grinder in the storage area.
4. Lower both park legs, insert and secure the locking pins.
5. To help protect the cutting teeth place a board or similar under the teeth that are resting on the floor.
6. Lower the stump grinder onto storage area.
7. Disengage the PTO, turn off the tractor engine, remove and pocket the key, and check that all rotating parts have come to a standstill before approaching the implement..
8. Disconnect the PTO drive-line.
9. Remove the stump grinder from the tractor's three-point hitch system.
10. To protect the PTO from damage or contamination always use the PTO drive-line support chain when the unit is in storage.



CAUTION

Heavy or bulky parts

Prevent potential strain injury, use approved lifting equipment or ask for help when lifting or moving heavy, bulky parts.



WARNING

Puncture Hazard

Rotor teeth have sharp edges, cover and protect from people coming in direct contact, serious injury could result.

SERVICE AND MAINTENANCE

Good maintenance is your responsibility. Poor maintenance is an invitation to trouble.

To keep your stump grinder in good working condition, and increase bearing life as well as maintain ease of operation, periodic lubrication is essential. This also helps to flush out moisture and dirt.

By following a careful service and maintenance program for your machine, you will enjoy many years of trouble-free operation.

Replacement of parts should be done by a qualified personnel only. Keep a record of all maintenance, to ensure scheduled inspections and maintenance are performed.

MAINTENANCE SAFETY CHECKLIST

- ✓ Follow good shop practices.
- ✓ Keep service area clean and dry.
- ✓ Use adequate light for the job at hand.
- ✓ Never work under equipment unless it is blocked securely
- ✓ Parts replacement should be performed by qualified personnel to ensure safe and complete installation.
- ✓ A fire extinguisher and first aid kit should be kept readily accessible.
- ✓ Always use personal protection devices such as eye, hand, foot and hearing protectors.
- ✓ Use heavy gloves when handling heavy or sharp components.
- ✓ When replacing parts, ensure hardware is properly torqued.

GENERAL MAINTENANCE

Before lubricating and inspection, ensure the grinder is clean and free of debris. Check under the HDPE deflector, rotor hood and around the PTO drive-line and clean out any material buildup.

On a regular basis check all nuts, bolts and screws and ensure they are all properly secured.

The PTO slip clutch must be inspected and adjusted before first use or after a storage period. The clutch can become locked up over time or due to dirt, corrosion or condensation even if the implement is stored indoors. Lock up can prevent the clutch plates from slipping during operation, resulting in high loads and possible damage to PTO, implement or tractor components.



WARNING Puncture Hazard

Rotor teeth have sharp edges, use caution when working around the rotor, serious injury could result .



CAUTION Operational Hazard

Personal Protection Equipment (PPE) is required when operating or maintaining this machine.



CAUTION Operational Hazard

When repairing or maintaining the unit ensure power unit is off and the key is removed and pocketed.



LUBRICATION

GREASE

Inspect bearings and components before each use. Unusual play or noise could be an indication of worn parts. Parts replacement should be performed by qualified personnel.

To prevent premature wear the grease fittings on the stump grinder bearings should be greased every 20 hrs or daily with heavy use.

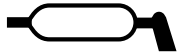

This symbol indicates a grease fitting location shown in the illustrations below.

- Lubricate with an good Lithium EP2 grease or equivalent.
- Use a hand-held grease gun for all greasing, one pump of grease is usually adequate. A full bearing with slight leakage through the seal is the best protection against contaminant entry.
- Wipe grease fitting with a clean cloth before greasing, to avoid injecting dirt and grit.
- Replace any broken grease fittings immediately.
- If grease fitting will not take grease, remove and clean thoroughly. Also clean lubricant passageway. Replace fittings if necessary.

LUBRICATE

Inspect the grinder components before each use. Unusual play or noise could be an indication of worn parts. Parts replacement should be performed by qualified personnel.

To ensure freedom of movement and prevent corrosion the stump grinders components should be lubricated every 20 hrs or more often with heavy use.



This symbol indicates a lubrication point shown in the illustrations below.

- Use a light oil or lubricating spray.

WARNING **Puncture Hazard**

Rotor teeth have sharp edges, use caution when working around the rotor, serious injury could result .

CAUTION **Operational Hazard**

Personal Protection Equipment (PPE) is required when operating or maintaining this machine.

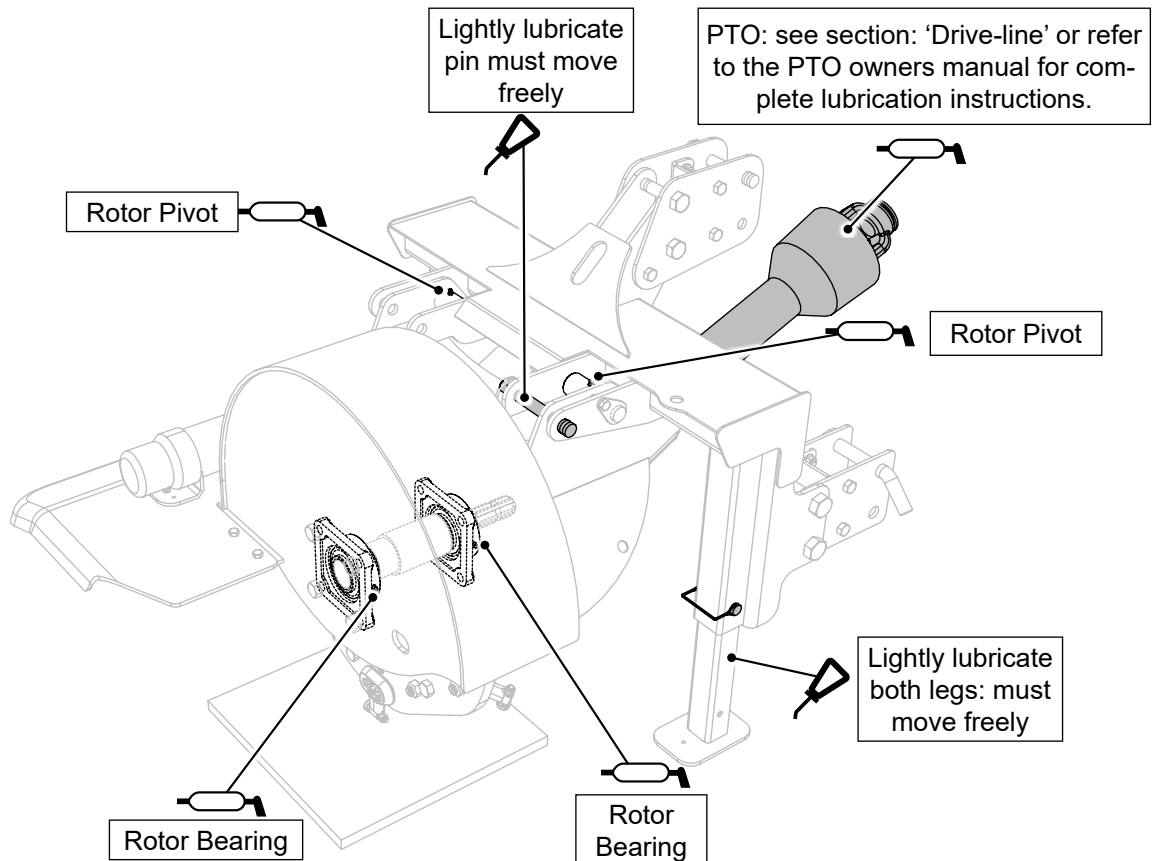

CUTTING WHEEL

The 25" rotor is equipped with 18 replaceable WearSharp® carbide cutting teeth, mounted in alloy steel tooth pockets. Periodic inspection of the cutting teeth and pockets is recommended to keep the stump grinder performing at its best. Due to the high wear nature of these parts, and the vibration they are subjected to we recommend you inspect your teeth after each use and check all pocket fasteners weekly at a minimum.

For stability we recommended that the stump grinder is attached to the tractor when replacing rotor components.

- Park tractor on a level surface.
- Engage tractor park brake.
- Disengage PTO.
- Shut off engine and remove key.
- Support grinder frame with safety stands to prevent accidental lowering.

Tooth replacement is relatively straight forward and can be done in the field. We recommend that pocket holders be replaced in shop, as they may require some extra effort to remove and ensure they are secure.

New cutting teeth, lock-nuts, spacers and pockets are available from your dealer or Wallenstein Equipment.

INSPECT CUTTING TEETH

The rotor is equipped with 18 teeth equipped with three cutting edges on each tooth. The teeth can be indexed (rotated) twice from their original position allowing for extended tooth life. Due to the wear and shock these parts are subjected to, when replacing teeth we recommend replacing lock-nuts and spacers at the same time.

A good indication it is time to rotate them:

- If you are noticing decreased cutting performance and or rotation speed is noticeably reduced.
- Visibly noting the relief angle on the tooth approaches approximately 50% of the carbide thickness (decreased diameter).
- In extreme cases when teeth are chipped, broken or missing, replacement is required.

INDEXING CUTTING TEETH

Tools needed: ½" Wrench, wire brush.

- Use a wire brush to clean around the pockets and hardware.
- Using the wrench loosen the locknut that secures the tooth into the pocket (no need to remove the nut completely).
- Tap the tooth out so that the tooth is free and clears the shoulder on the pocket and can be rotated.
- Rotate the tooth a third of a turn.
- Reposition the tooth in it's seat. The teeth are designed to rotate in thirds and should fit snugly back into the pocket.
- Re-tighten the locknut to proper torque specifications:
20 ft.lbs. (27 Nm)

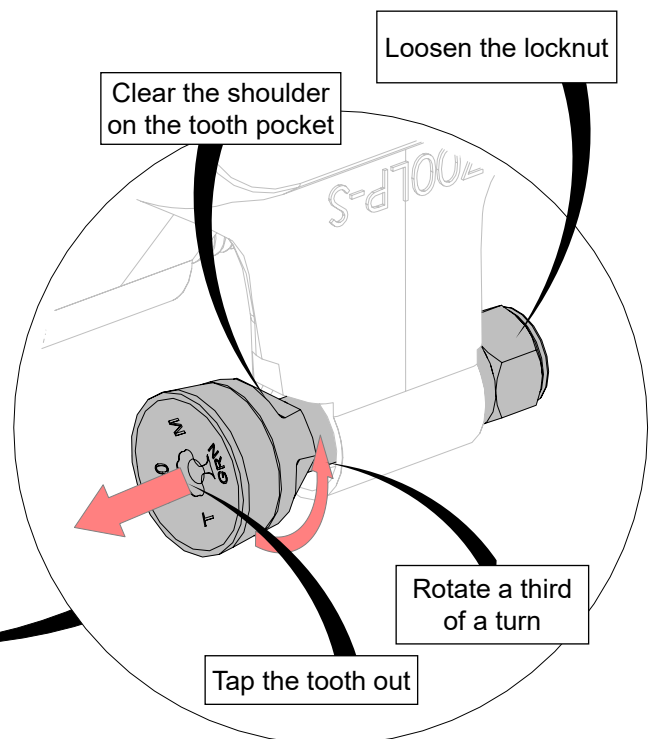

WARNING **Operational Hazard**

Replacement parts must be properly torqued, under or over torque can cause premature wear or damage leading to personal injury.

REPLACING CUTTING TEETH

To replace the tooth, follow the indexing instructions and simply remove the locknut and replace the worn tooth with a new one.

- Using a wire brush, clean around the pockets and hardware to make removal easier.
- Using the wrench remove the locknut and spacer then discard.
- Tap the tooth so that the tooth is free from it's seat, remove and discard.
- Position the tooth in it's seat, it should fit snugly into the pocket.
- Assemble the spacer and hand tighten the locknut.
- Tighten the locknut to proper torque specifications: **20 ft.lbs. (27 Nm)**

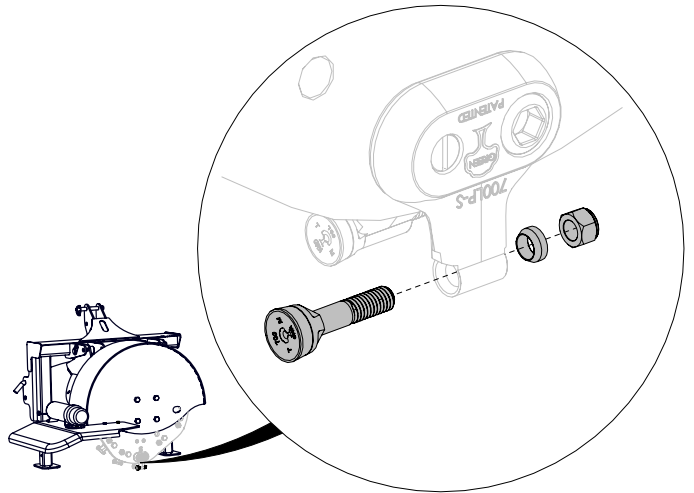

REPLACING TOOTH POCKETS

If the pocket is damaged or broken it will have to be replaced. Due to the wear and shock these parts are subjected to, when replacing pockets we recommend replacing both bolts and nuts at the same time.

There are three types of pockets mounted on the rotor, determine which pocket you require:

- Angled
- Straight
- Reverse Angled

Tools needed:

- Wire brush
- $\frac{15}{16}$ " Wrench
- $\frac{1}{2}$ " Wrench
- $\frac{1}{2}$ " 6pt Allen Wrench
- Anti Seize Compound

To replace a pocket:

- Using a wire brush, clean both sides of the rotor around the pockets and hardware to make removal easier.
- Make note of the orientation and type of the pocket to be removed.
- Using the $\frac{1}{2}$ " allen and $\frac{15}{16}$ " wrench to remove the bolts from each side of the pocket. (allen wrench only for double pockets)
- Discard the old bolts and tooth pocket.
- Using a wire brush, clean both sides of the wheel where it will come in contact with the pockets and hardware. Be sure to remove all dirt and debris so the pocket is seated tightly against the wheel.
- Fit the new matching pocket on the rotor in the same orientation and side as the old one.
- Using a dab of anti seize on the new bolt threads, install the bolts on each side of the pocket.
- Tighten the bolts to torque specs: **180 ft.lbs - 244 Nm .** (240 ft.lbs. - 325 Nm, with out anti-seize).
- Complete the installation by following the steps under 'Replacing Cutting Teeth' to install the cutting teeth.

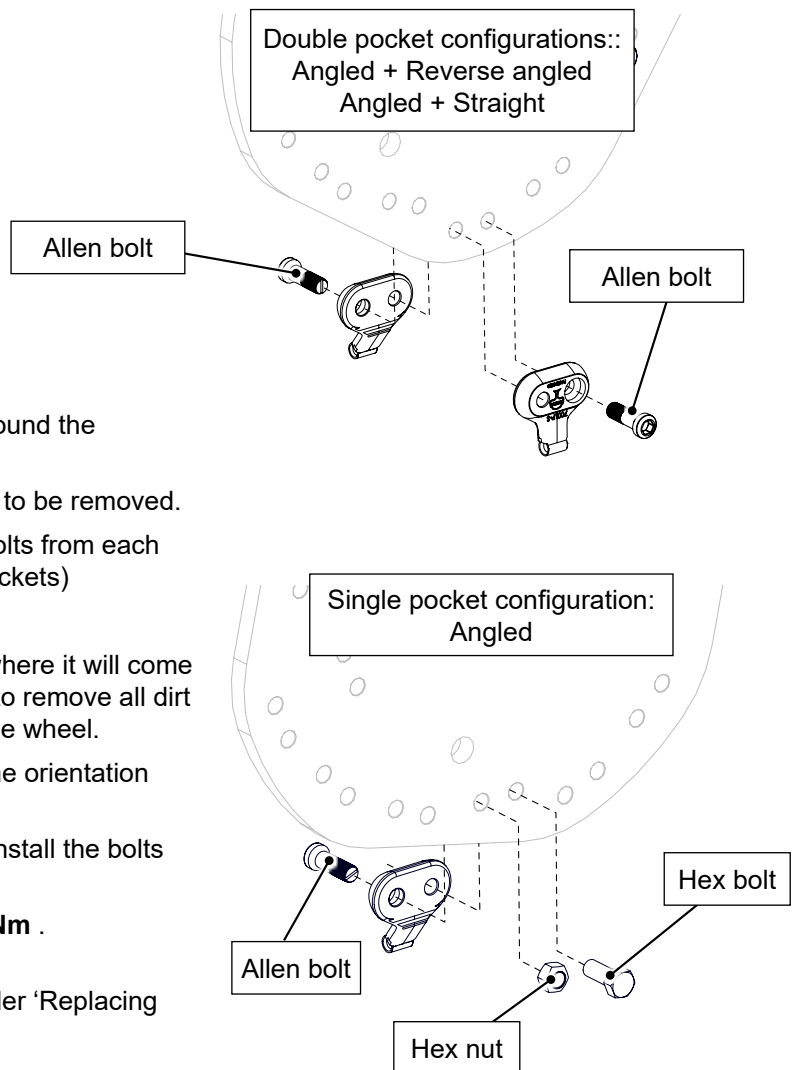

DRIVE-LINE

PTO DRIVE-LINE CLUTCH

The slip clutch must be adjusted before first use or after a storage period. The clutch can become locked up over time or due to dirt, corrosion or condensation even if the implement is stored indoors.

Disengage tractor PTO, shut off engine and remove key. Have the stump grinder mounted and the drive-line not installed, and follow the steps below before using your stump grinder to ensure the PTO drive-line clutch plates are set properly.

! This procedure should be performed periodically as the clutch plates can stick together, particularly after periods of inactivity. Stuck plates prevent the clutch from slipping during operation as designed, resulting in high loads and possible damage to the steel shaft or tractor drive components.

- At the clutch end, using a marker, scribe a line across the exposed edges of the hub clutch plate and friction discs.
- Loosen each compression nut exactly two revolutions to free up the clutch friction discs.
- Install the drive-line.
- Start tractor and run drive-line at a low idle to slip the friction discs. This will remove any the dirt, corrosion from clutch plate faces.
- Disengage tractor PTO. Shut off engine and remove key.
- Inspect the clutch and ensure that the scribed markings on the disc and plates have changed position. If any two marks are still aligned, that is an indication that these discs have not slipped. Repeat the two previous steps.
- If any markings have not moved, disassembly may be required to free up the disks.
- After ensuring all discs are free, tighten the compression nuts uniformly in a star pattern, exactly two revolutions each to reset the clutch to original pressure. (see spring height diagram in maintenance for reference)
- The clutch should be checked during the first hour of use and periodically each week thereafter.
- Be aware of unusual clutch plate slippage, burning odor, or visible smoking, further adjustment may be required.

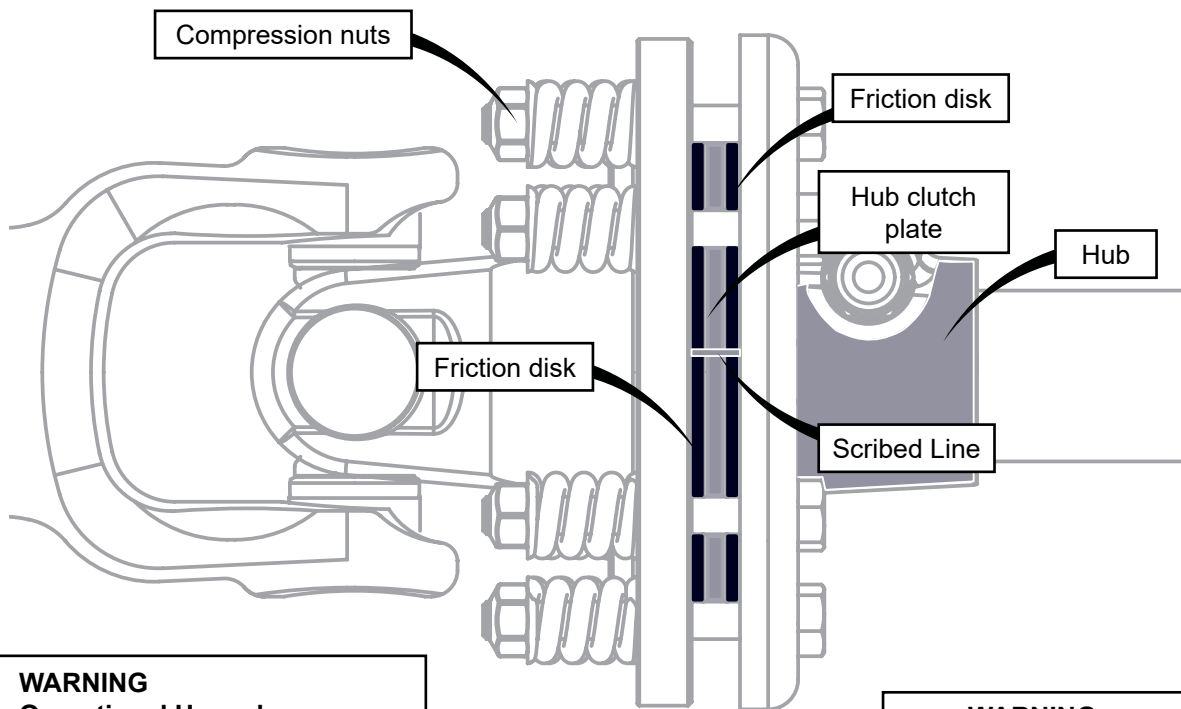

WARNING

Operational Hazard

The clutch should be checked periodically each week. Excessive clutch plate slippage, burning odour, or visible smoking should not be observed during use.



WARNING

Operational Hazard

To protect the PTO drive-line from damage or contamination, always use the PTO drive-line support when the unit is not in use.

PTO DRIVE-LINE CLUTCH SPRING HEIGHT

After any clutch adjustment check that the clutch springs are adjusted to the correct height. Height will vary depending on the horse power of your tractor.

Lower horsepower will require less compression (more height), while higher horsepower tractors will require greater compression (less height).

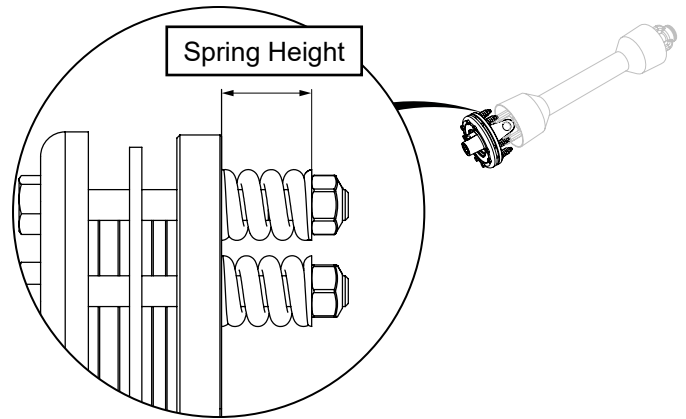

LUBRICATION

Lubricate with an good EP grease or equivalent (Epic EP 102). Refer to the lubrication illustration below for location and timing.

- Use a hand-held grease gun for all greasing, one pump of grease is adequate.
- Wipe grease fitting with a clean cloth before greasing, to avoid injecting dirt and grit.
- Replace any broken grease fittings immediately.
- If grease fitting will not take grease, remove and clean thoroughly. Also clean lubricant passageway. Replace grease fittings if necessary.
- Separate the drive-line to lubricate the tubes
- Use a light oil or lubricating spray for yoke lock components

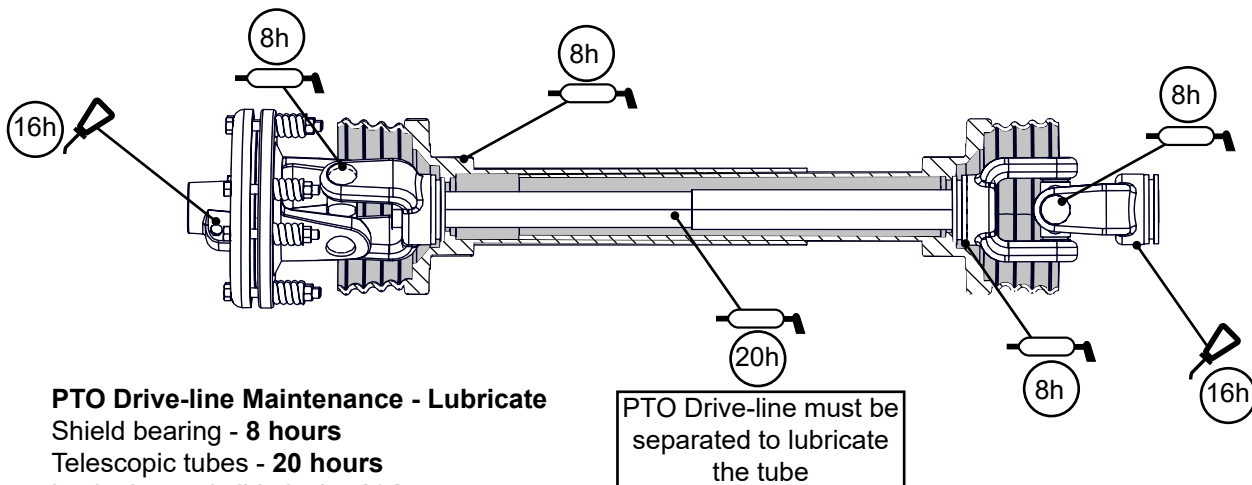

PTO Drive-line Maintenance - Lubricate
 Shield bearing - **8 hours**
 Telescopic tubes - **20 hours**
 Lock pins and slide lock - **16 hours**
 U-joint - **8 hours**

CAUTION
Operational Hazard
 When repairing or maintaining the unit ensure power unit is off and the key is removed and pocketed.

CAUTION
Operational Hazard
 Personal Protection Equipment (PPE) is required while assembling or maintaining this machine.

CAUTION
Heavy or bulky parts
 Prevent potential strain injury, use approved lifting equipment or ask for help when lifting or moving heavy, bulky parts.

WARNING
Operational Hazard
 To protect the PTO drive-line from damage or contamination, always use the PTO drive-line support when the unit is not in use

BOLT TORQUE TABLE

These tables are offered as the suggested maximum torque values for dry (not lubricated) threaded products and are only a general guide.

Check tightness of bolts periodically, replace hardware with the same strength bolt.

Torque specification for bolts are identified by their head markings as shown.

METRIC TORQUE SPECIFICATIONS

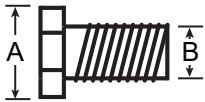

Wrench Size: "A"	Thread Size: "B" Fine	Class 8.8		Class 10.9		Thread Size: "B" Coarse	Class 8.8		Class 10.9	
		N-m	lbs-ft	N-m	lbs-ft		N-m	lbs-ft	N-m	lbs-ft
10 mm	6 x 0.75	---	---	---	---	6 x 1.0	11.3	8.3	16.5	12.2
13 mm	8 x 1.0	27	20	38	28	8 x 1.25	27.3	20.1	40.1	29.6
16 mm	10 x 1.25	52	38	73	54	10 x 1.5	54	40	49	36
18 mm	12 x 1.25	95	70	135	100	12.1.75	93	69	137	101
21 mm	14 x 1.5	150	111	210	155	14 x 2.0	148	109	218	161
24 mm	16 x 1.5	225	166	315	232	16 x 2.0	230	170	338	249
27 mm	18 x 1.5	325	240	460	339	18 x 2.5	329	243	469	346
30 mm	20 x 1.5	460	339	640	472	20 x 2.5	464	342	661	487
34 mm	22 x 1.5	610	450	860	634	22 x 2.5	634	468	904	667
36 mm	24 x 2.0	780	575	1100	811	24 x 3.0	798	588	1136	838
41 mm	27 x 3.0	---	---	---	---	27 x 3.0	1176	867	1674	1234
46 mm	30 x 2.0	---	---	---	---	30 x 3.0	1597	1178	2274	1677

SAE TORQUE SPECIFICATIONS

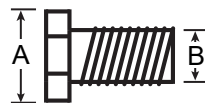

Wrench Size: "A"	Thread Size: "B" Fine	SAE 2		SAE 5		SAE 8		Thread Size: "B" Coarse	SAE 2		SAE 5		SAE 8	
		lbs-ft	N-m	lbs-ft	N-m	lbs-ft	N-m		lbs-ft	N-m	lbs-ft	N-m	lbs-ft	N-m
7/16"	1/4-28	6	8.1	10	13.6	14	19.0	1/4-20	5	6.8	8	10.8	12	16.3
1/2"	5/16-24	13	17.6	19	25.7	27	36.6	5/16-18	11	14.9	17	23.0	25	33.9
9/16"	3/8-24	23	31.2	35	47.4	49	66.4	3/8-16	20	27.1	31	42.0	44	59.6
5/8"	7/16-20	36	48.8	55	74.5	75	101.6	7/16-14	32	43.4	49	66.4	70	94.9
3/4"	1/2-20	55	74.5	85	115.2	120	162.6	1/2-13	49	66.4	75	101.6	107	145.0
13/16"	9/16-18	79	107.0	122	165.3	172	233.1	9/16-12	70	94.9	109	147.7	154	208.7
15/16"	5/8-18	110	149.1	170	230.4	240	325.2	5/8-11	97	131.4	150	203.3	212	287.3
1-1/8"	3/4-16	192	260.2	297	402.4	420	569.1	3/4-10	173	234.4	266	360.4	376	509.5
1-5/16"	7/8-14	184	249.3	474	642.3	668	905.1	7/8-9	166	224.9	429	581.3	606	821.1
1-1/2"	1.0-12	274	371.3	705	955.3	995	1348.2	1.0-8	250	338.8	644	872.6	909	1231.7

TROUBLESHOOTING

On the following pages, we have listed many of the causes and solutions to issues that you may encounter.

If you encounter an issue that is difficult to solve, even after having read through this troubleshooting section, please call your local dealer or Wallenstein Equipment. Before you call, please have this Operator's Manual and your serial number ready.

Problem	Cause	Solution
The cutting disk stops during cutting.	Cutting too deep.	Decrease cutting depth
	Cutting too fast	Move slower across the stump
	Rotor jammed.	Remove jam material from rotor
Rotor stub shaft broken.	Driveshaft angle is too severe	Stay within PTO ANGLE specs, replace stub
	Locked up slip clutch	Perform PTO clutch maintenance, replace stub
The grinder rotor does not cut fast enough, lacking cutting power.	Teeth are worn, damaged, or broken	Rotate or replace any worn, damaged or broken teeth
	Cutting tooth pocket damaged, or broken	Replace cutting tooth pocket
	Slip clutch is slipping.	Perform PTO clutch maintenance, check adjustment of clutch spring. Caution: Clutch may be very hot!
	Cutting too deep.	Decrease cutting depth
	Cutting too fast	Move slower across the stump
	Tractor not set to full throttle	Set tractor to full throttle: max 540 RPM
	Tractor too small.	Use tractor within size specifications
	Tractor too powerful	Use tractor within size specifications. Slippage on the clutch occurs if there is more power than the unit is rated for. Caution: Clutch may be very hot! Idle down: this will decrease the output power of the engine.
Tractor is not able to lift the machine.	Tractor is too small.	Move link pins to the top position on the stump grinder to add leverage.
		Use tractor within size specifications
Rotor cannot be lifted high enough.	Stump too tall.	Cut stump shorter.

On the following page, we have listed many of the causes and solutions to issues that you may encounter.

If you encounter a issue that is difficult to solve, even after having read through this troubleshooting section, call your local dealer or Wallenstein Equipment. Before you call, have this Operator's Manual and your serial number ready.

Problem	Cause	Solution
Rotor cannot be lowered far enough.	Top link not correct length.	Lengthen top link on 3-point hitch, stay within PTO angle specifications.
Stump grinder vibrating, bouncing	Rotor turning wrong direction	Ensure rotor is turning clockwise while standing behind the tractor.
	Too much pressure on grinder	Raise the grinder up slightly to allow the head to float.
	Dense material, cutting too fast, worn teeth	Move slower across the stump. Perform maintenance on cutting teeth.
	Starting cut on the wrong side or middle of the stump	Always start on the right side and move forward from the front to the back of the stump
Smoke or burning smell	Slip clutch is slipping.	Perform PTO clutch maintenance, check adjustment of clutch spring. Caution: Clutch may be very hot!
		Move slower across the stump.
	Cutting too fast, worn teeth	Move slower across the stump. Perform maintenance on cutting teeth.
Broken or damaged cutting teeth or tooth pockets	Impact with foreign objects	Check for imbedded objects in the stump or rocks or buried metal below the soil.

ACCESSORIES

For accessories or replacement parts, call your dealer or go to WallensteinEquipment.com for pricing and availability.

#132369 HITCH EXTENSION KIT

Extension bracket kit will add an additional 6.0" (153mm) to the space between the tractor output shaft and the grinder input shaft to facilitate the safe installation of the PTO shaft.

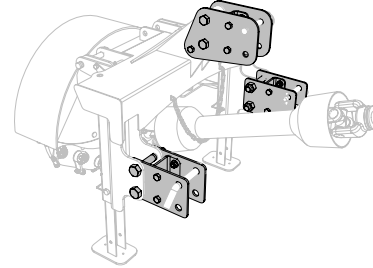

DS510 DEBRIS SCREEN

Used in areas where debris from the stump grinder needs to be contained, includes 4 posts with integrated ground spikes.

- 10' wide by 5' high
- 9 oz 1000D woven PVC coated polyester

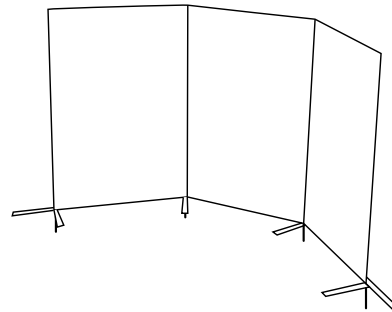



LIMITED WARRANTY

Wallenstein products are warranted to be free of defects in materials and workmanship under normal use and service, for a period of

Five Years for Consumer Use

Two Years for Commercial/Rental Use

from the date of purchase, when operated and maintained in accordance with the operating and maintenance instructions supplied with the unit. Warranty is limited to the repair of the product and/or replacement of parts.

This warranty is extended only to the original purchaser and is not transferable.

Repairs must be done by an authorized dealer. Products will be returned to the dealer at the customer's expense. Include the original purchase receipt with any claim.

This warranty does not cover the following:

- 1) Normal maintenance or adjustments
- 2) Normal replacement of wearable and service parts
- 3) Consequential damage, indirect damage, or loss of profits
- 4) Damages resulting from:
 - Misuse, negligence, accident, theft or fire
 - Use of improper or insufficient fuel, fluids or lubricants
 - Use of parts or aftermarket accessories other than genuine Wallenstein parts
 - Modifications, alteration, tampering or improper repair performed by parties other than an authorized dealer
 - Any device or accessories installed by parties other than an authorized dealer
- 5) Engines. Engines are covered by the manufacturer of the engine for the warranty period they specify. For the details of your engine warranty, see your engine owner's manual. Information about engine warranty and service is also available in the FAQ section at www.wallensteinequipment.com

rev. Nov-2018



MAKING WORK FEEL MORE LIKE PLAY™

WallensteinEquipment.com

