

Set-up Instructions

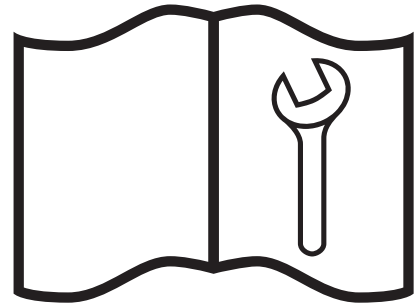

WX310

WX320

WX330



IMPORTANT! Inspect for damage from shipping. Immediately contact the shipping company if damage is found.

*Note: Some parts are attached to skid with screws.
Shipping brackets are not reused.*

Always Put Safety First!

Read these assembly instructions thoroughly before beginning. Make sure each step is understood before attempting it. Be familiar with all safety signs on the machine and their meaning.

Tighten all fasteners to the torque value specified on the last page. Recheck before using the machine.

Assembly hardware is located inside operator's manual tube.



WARNING!

Position the crate in a large open area to allow access from all sides during assembly.

Stay clear of overhead power lines and obstructions when lifting the machine during assembly. Contact with power lines can cause electrocution. Contact with obstructions can damage components or cause them to fail.

Keep the assembly area clean to prevent slipping or tripping.

Use a hoist when lifting components that weigh 50 lb (23 kg) or more to avoid back injury.

All lifting devices (straps, slings, chains, ratchet blocks) must comply with applicable local regulations and certifications. Wallenstein Equipment Inc. cannot accept responsibility for the use of sub-standard equipment and work practices.

Use lifting equipment with a capacity greater than the weight of the component. Place jack stands or wood blocking under the machine to securely stabilize it before working on it during assembly.

Use the correct tool for the job. Repair or replace broken or defective equipment or tools. Makeshift tools can create safety hazards. A tool that breaks or slips during use risks personal injury.



WARNING!

Avoid the risk of personal injury or machine damage! Read the operator's manual before using this equipment. Carefully read all safety messages in the manual and follow all safety signs on the machine.

WX310

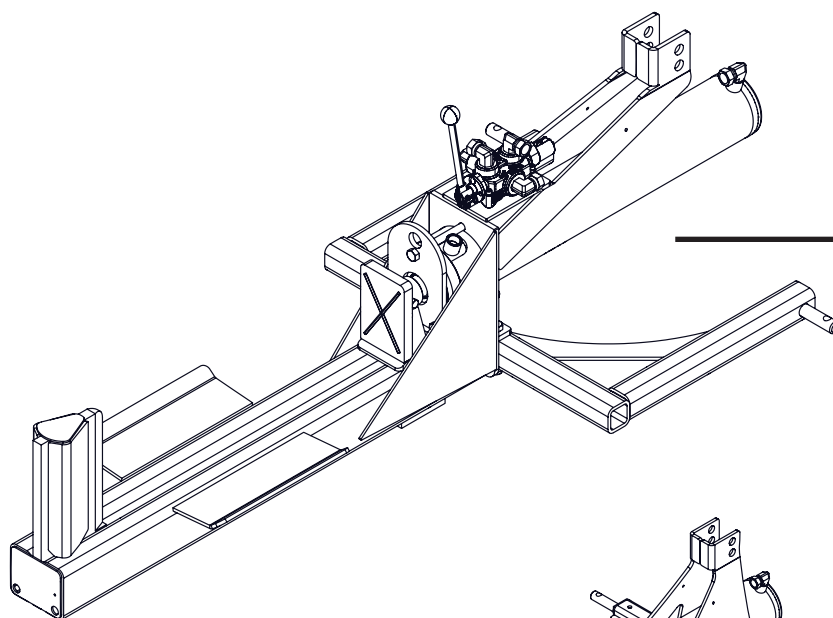

WX310

WX320

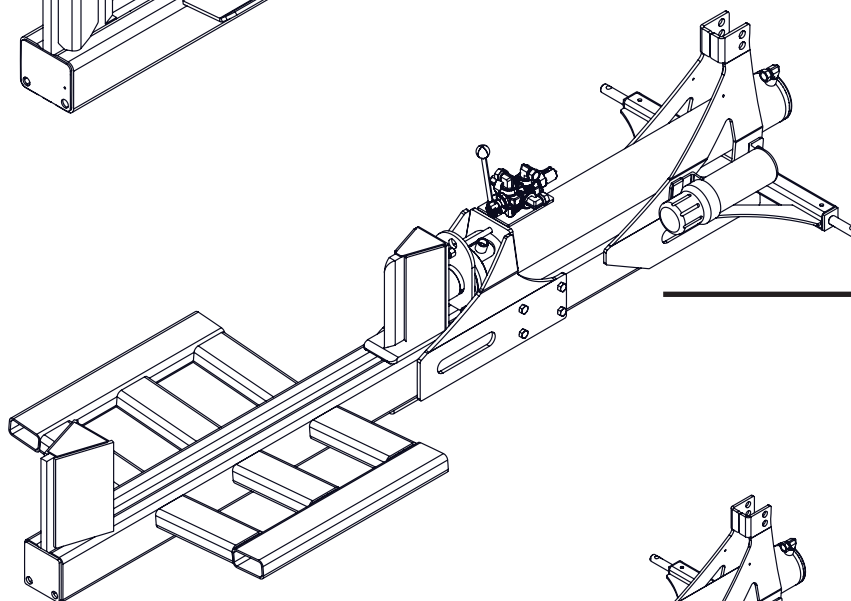

WX320

WX330

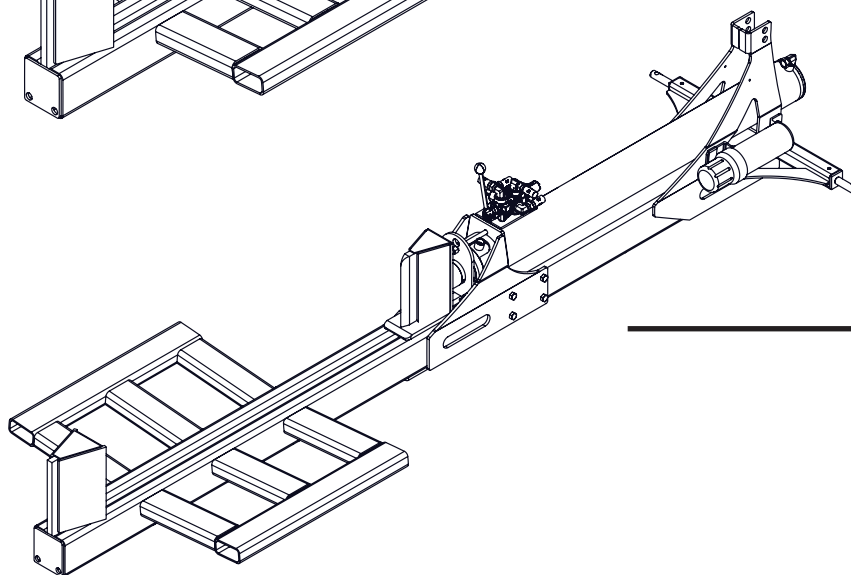

WX330

1

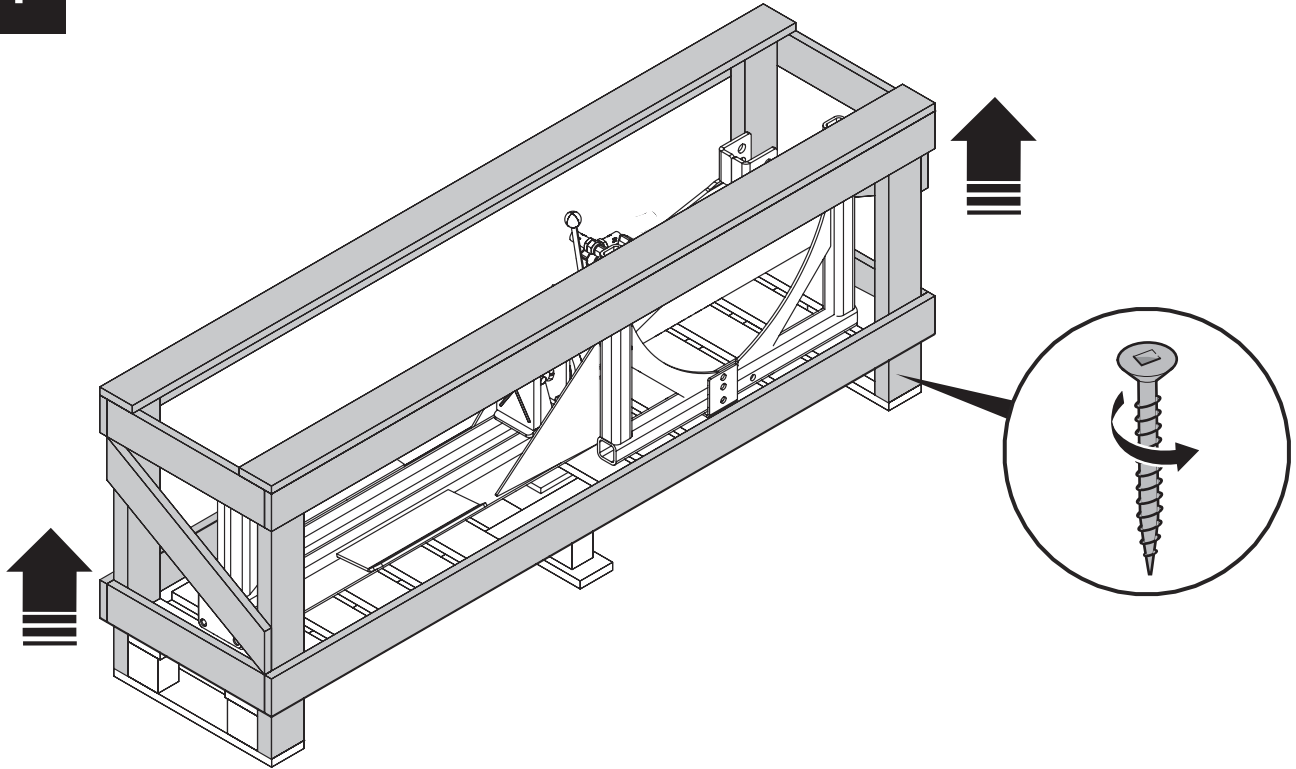

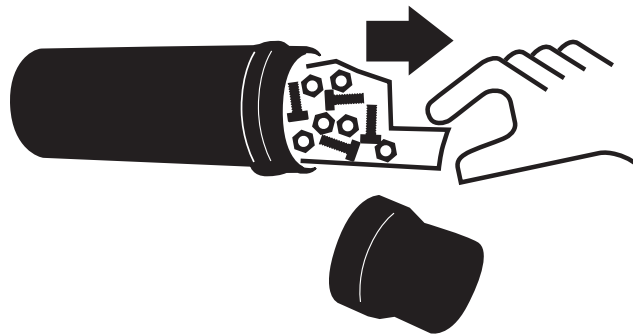
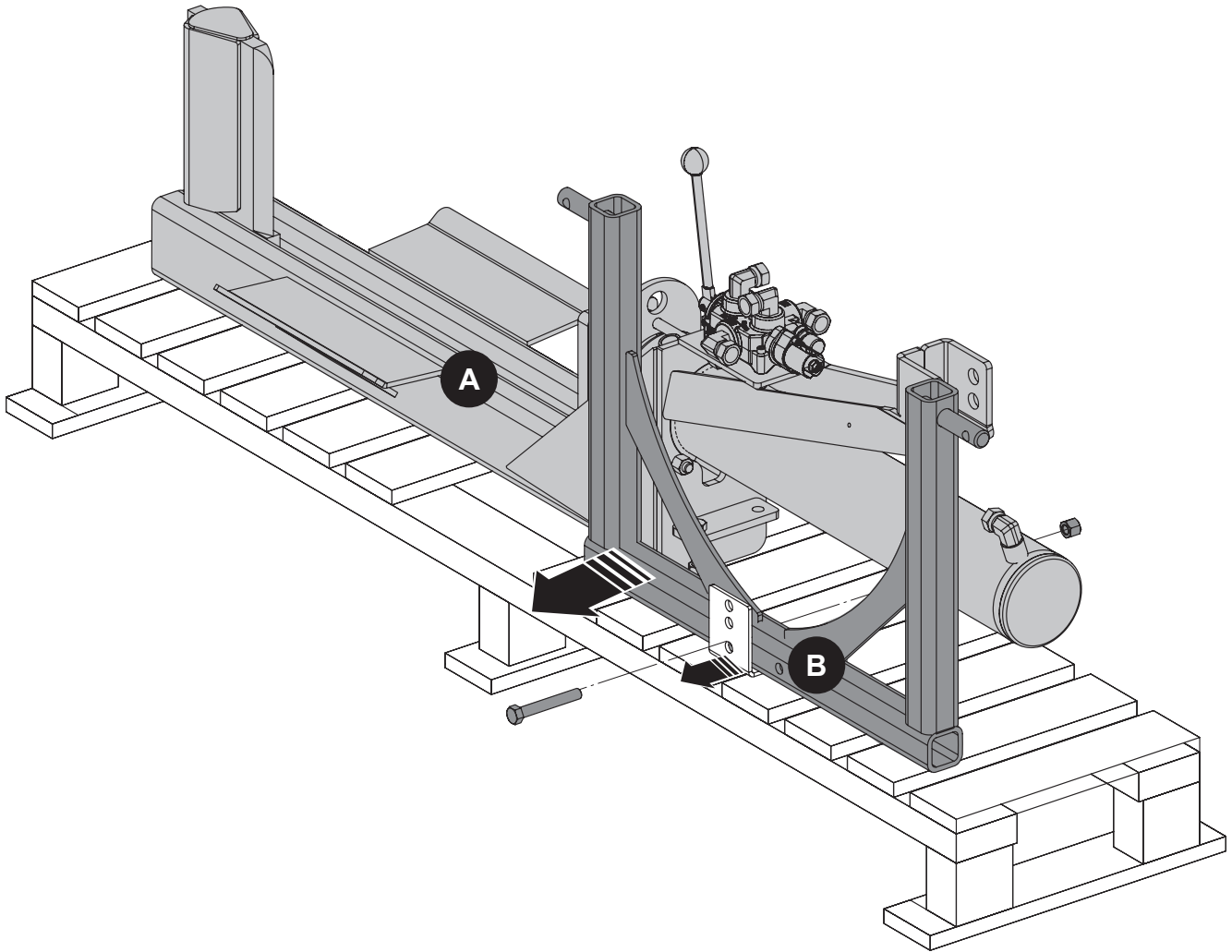

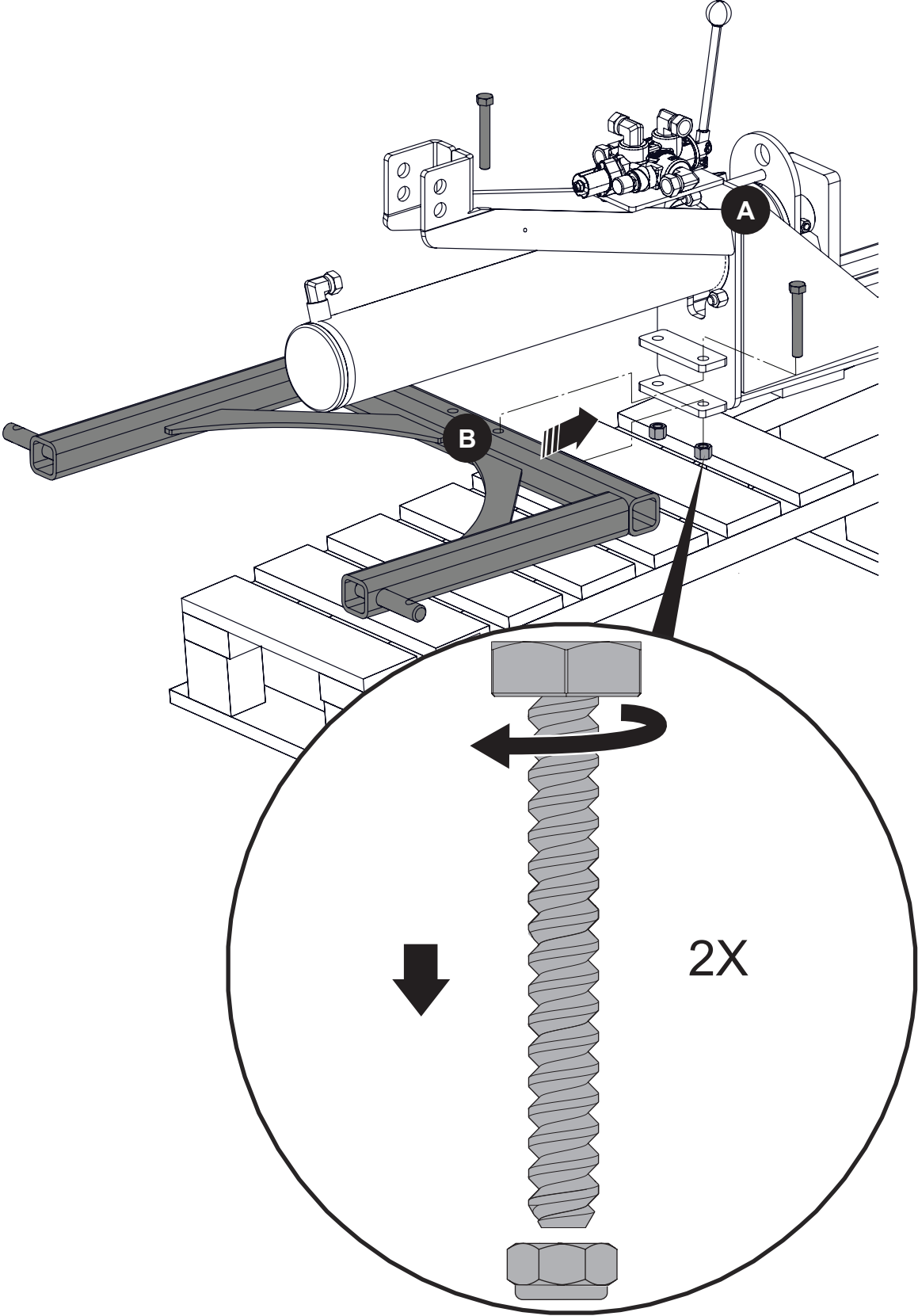

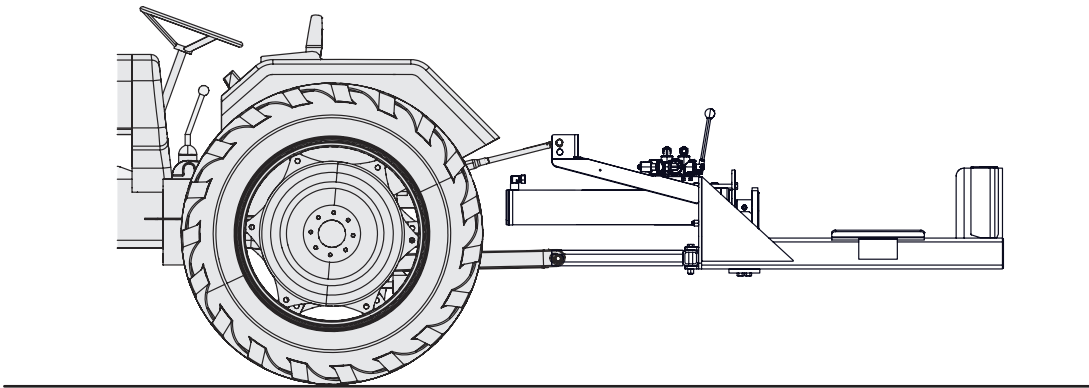
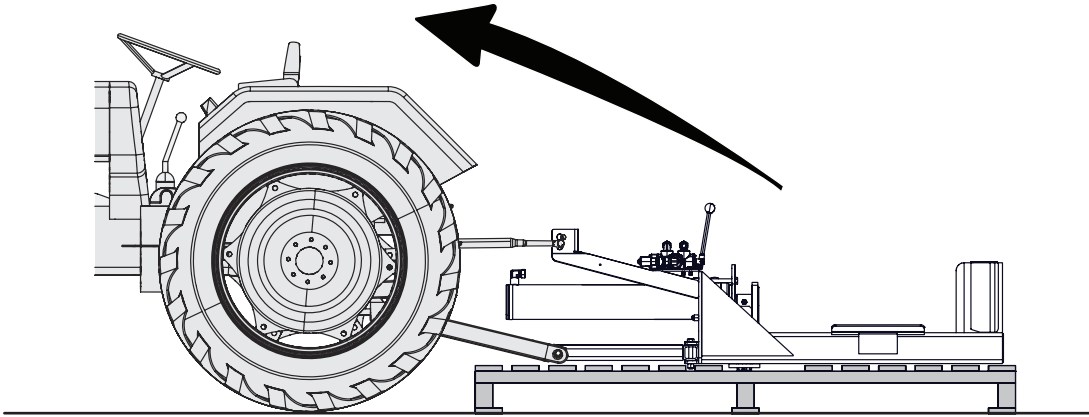

1

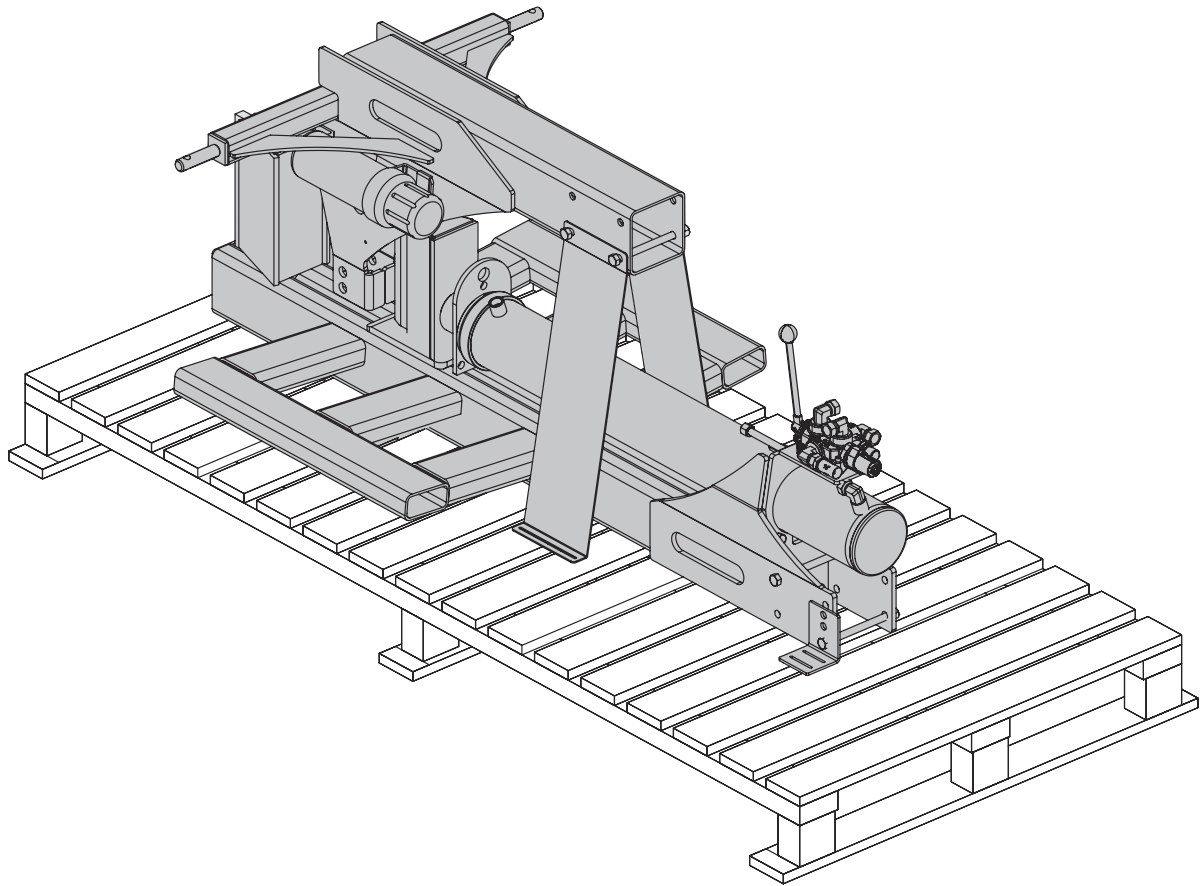

2

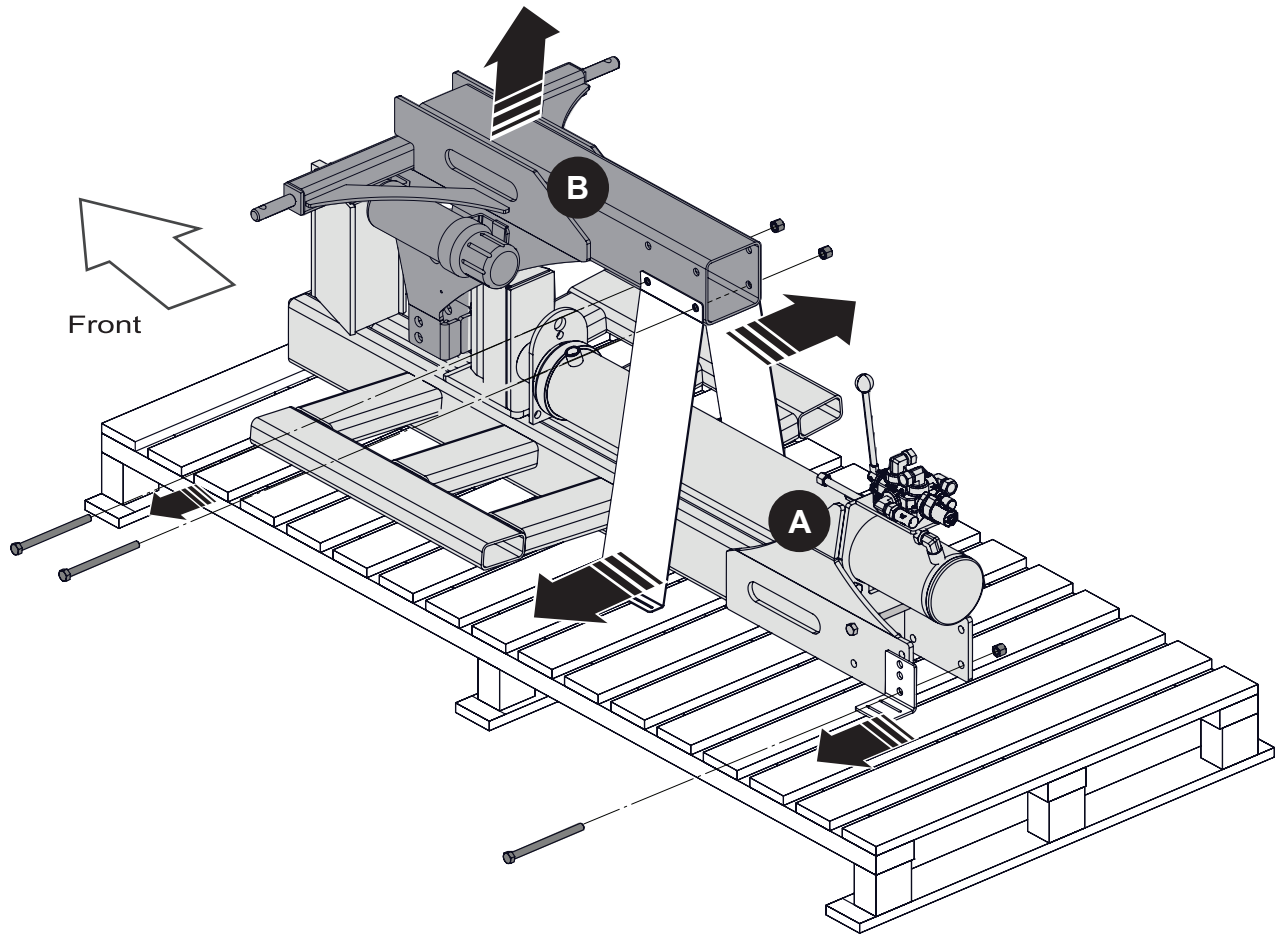

WX320

WX330

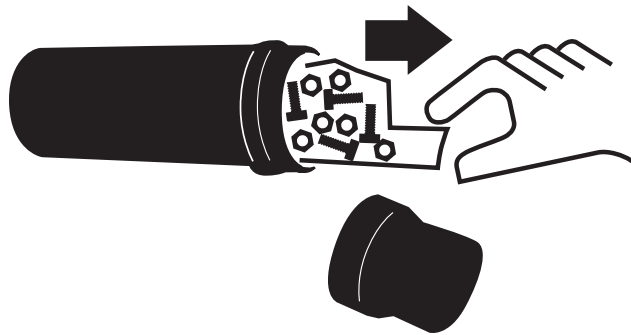

3

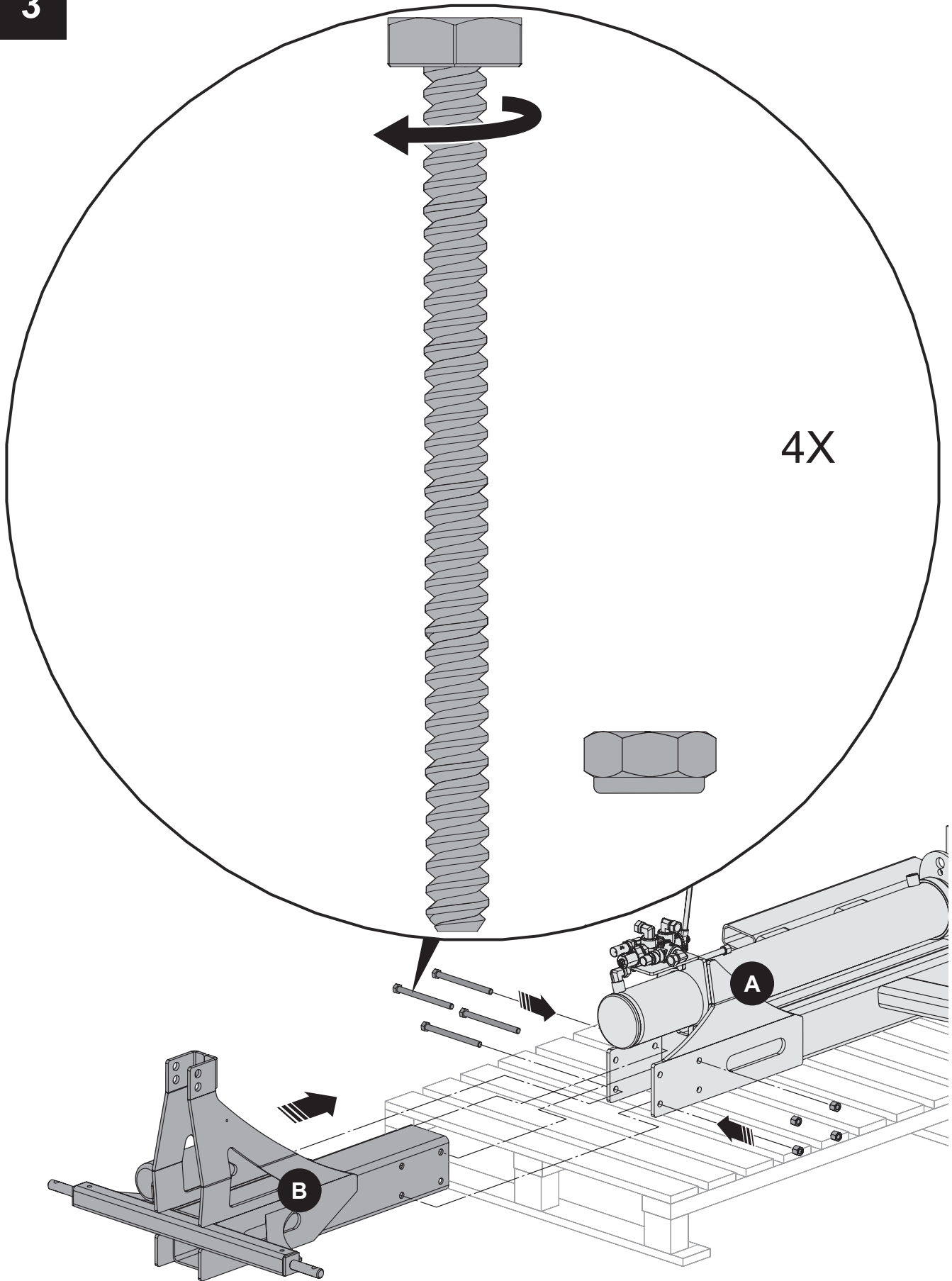

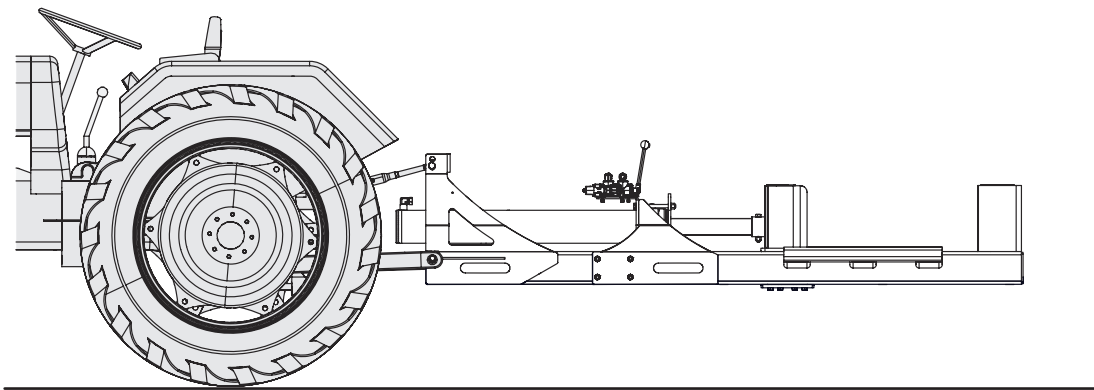
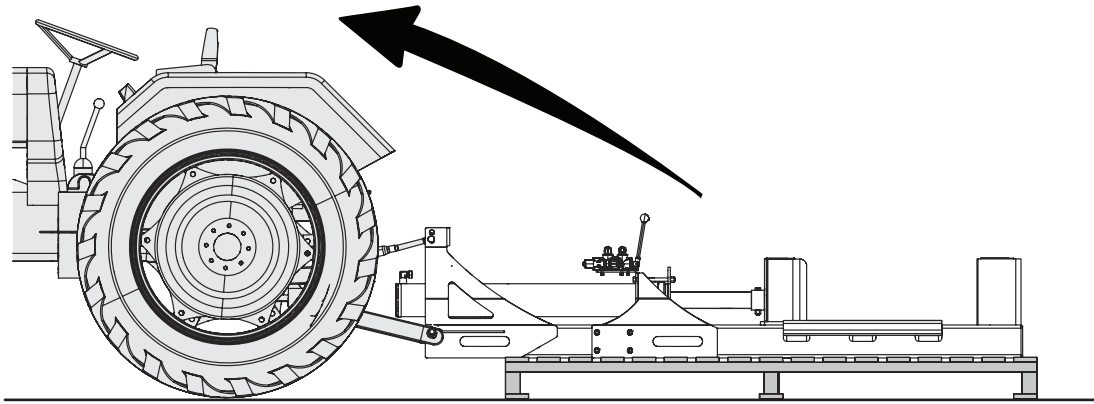

WX320

WX330

5

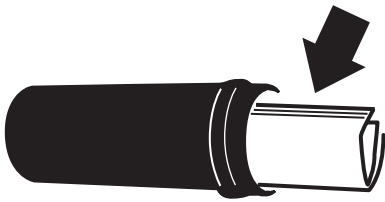

Pre-delivery Inspection	
Inspect for damage from shipping. Immediately contact the shipping company if damage is found.	
Three-point Hitch Wood Splitter	
	Hydraulic Valve Control Function
	Hydraulic Cylinder Function
	All fasteners are Tight
	Hydraulic Connections are tight
Safety Checks	
	All Safety Decals Installed
	Guards and Shields Installed and Secured
	Review Operating and Safety Instructions

Bolt Torque Specifications

Checking Bolt Torque

The tables shown give correct torque values for various bolts and capscrews. Tighten all bolts to the torque values specified in the table, unless indicated otherwise. Check tightness of bolts periodically.

IMPORTANT! If replacing hardware, use fasteners of the same grade.

IMPORTANT! Torque figures indicated in the table are for non-greased or non-oiled threads. Do not grease or oil threads unless indicated otherwise. When using a thread locker, increase torque values by 5%.

Note: Bolt grades are identified by their head markings.

Imperial Bolt Torque Specifications						
Bolt Diameter	Torque Value					
	SAE Gr. 2		SAE Gr. 5		SAE Gr. 8	
	lbf•ft	N•m	lbf•ft	N•m	lbf•ft	N•m
1/4"	6	8	9	12	12	17
5/16"	10	13	19	25	27	36
3/8"	20	27	33	45	45	63
7/16"	30	41	53	72	75	100
1/2"	45	61	80	110	115	155
9/16"	60	95	115	155	165	220
5/8"	95	128	160	215	220	305
3/4"	165	225	290	390	400	540
7/8"	170	230	420	570	650	880
1"	225	345	630	850	970	1320



SAE Gr. 2



SAE Gr. 5



SAE Gr. 8

Metric Bolt Torque Specifications				
Bolt Diameter	Torque Value			
	Gr. 8.8		Gr. 10.9	
	lbf•ft	N•m	lbf•ft	N•m
M3	0.4	0.5	1.3	1.8
M4	2.2	3	3.3	4.5
M6	7	10	11	15
M8	18	25	26	35
M10	37	50	52	70
M12	66	90	92	125
M16	166	225	229	310
M20	321	435	450	610
M30	1,103	1 495	1,550	2 100
M36	1,917	2 600	2,700	3 675



8.8



10.9

Hydraulic Fitting Torque

1. Check flare and flare seat for defects that might cause leakage.
2. Align tube with fitting before tightening.
3. Hand-tighten swivel nut until snug.
4. To prevent twisting the tube, use two wrenches. Place one wrench on the connector body and tighten the swivel nut with the second. Torque to values shown.

If a torque wrench is not available, use the FFFT (Flats From Finger Tight) method.

Hydraulic Fitting Torque					
Tube Size OD	Hex Size Across Flats	Torque value		Flats From Finger Tight	
		lbf·ft	N·m	Flats	Turns
Inches	Inches				
3/16	7/16	6	8	2	1/6
1/4	9/16	11–12	15–17	2	1/6
5/16	5/8	14–16	19–22	2	1/6
3/8	11/16	20–22	27–30	1-1/4	1/6
1/2	7/8	44–48	59–65	1	1/6
5/8	1	50–58	68–79	1	1/6
3/4	1-1/4	79–88	107–119	1	1/8
1	1-5/8	117–125	158–170	1	1/8

Values shown are for non-lubricated connections.

Wheel Lug Torque

It is an extremely important safety procedure to apply and maintain proper wheel mounting torque on your trailer axle. Torque wrenches are the best method to assure the proper amount of torque is being applied to a fastener.

Wheel lugs should be torqued before first road use and after each wheel removal. Check and re torque after the first 10 miles (16 km), 25 miles (40 km), and again at 50 miles (80 km). Check periodically thereafter.



WARNING!

Wheel lug nuts must be installed and kept at the proper torque value to prevent loose wheels, broken studs, or possible separation of wheels from axle.

- Start all lug nuts onto the threads by hand.
- Tighten lug nuts in stages, following the pattern shown in the Wheel Lug Nut Torque table.

Wheel Lug Nut Torque				
Wheel Size	Units	1st Stage	2nd Stage	3rd Stage
8"	lbf·ft	12–20	30–35	45–55
	N·m	16–26	39–45.5	58.5–71.5
12"	lbf·ft	20–25	35–40	50–60
	N·m	26–32.5	45.5–52	65–78
13"	lbf·ft	20–25	35–40	50–60
	N·m	26–32.5	45.5–52	65–78
14"	lbf·ft	20–25	50–60	90–120
	N·m	26–32.5	65–78	117–156
15"	lbf·ft	20–25	50–60	90–120
	N·m	26–32.5	65–78	117–156
16"	lbf·ft	20–25	50–60	90–120
	N·m	26–32.5	65–78	117–156

Wheel Lug Torque Pattern

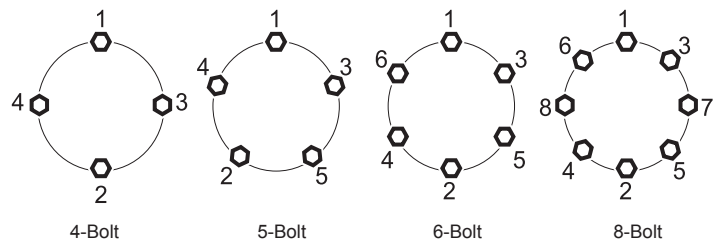

Couple appliqué sur les raccords hydrauliques

Serrage des raccords coniques de tube

1. Vérifiez l'évasement et le logement de l'évasement pour repérer la présence éventuelle de défauts qui peuvent causer une fuite.
 2. Alignez le tube sur le raccord avant de serrer.
 3. Serrez à fond l'écrou orientable jusqu'à ce qu'il soit bien serré.
 4. Pour éviter de tordre le tube, utilisez deux clés. Placez une des clés sur le bâti du connecteur et serrez l'écrou orientable avec la deuxième clé selon le couple indiqué. Serrez au couple selon les valeurs indiquées.
- Si vous n'avez pas de clé dynamométrique, utilisez la méthode FFT (Plaques avec serrage manuel).
- Les valeurs indiquées s'appliquent aux raccords non lubrifiés.

Couple appliqué sur les raccords hydrauliques						
Diamètre extérieur du tube	Pouces	Pouces	lb•pi	N•m	Plaques	Tours
Taille des écrous hexagonaux à travers les plaques						
3/16	7/16	6	8	2	1/6	
1/4	9/16	11-12	15-17	2	1/6	
5/16	5/8	14-16	19-22	2	1/6	
3/8	11/16	20-22	27-30	1-1/4	1/6	
1/2	7/8	44-48	59-65	1	1/6	
5/8	1	50-58	68-79	1	1/6	
3/4	1-1/4	79-88	107-119	1	1/8	
1	1-5/8	117-125	158-170	1	1/8	



Spécifications relatives au couple de serrage des boulons en unités métriques				
Diamètre du boulon	Gr. 8,8		Gr. 10,9	
	lb·pi	N·m	lb·pi	N·m
M36	1 917	2 600	2 700	3 675
M30	1 103	1 495	1 550	2 100
M20	321	435	450	610
M16	166	225	229	310
M12	66	90	92	125
M10	37	50	52	70
M8	18	25	26	35
M6	7	10	11	15
M4	2,2	3	3,3	4,5
M3	0,4	0,5	1,3	1,8



Spécifications relatives au couple de serrage des boulons en unités impériales				
Diamètre du boulon	SAE Gr. 2		SAE Gr. 5	
	lb·pi	N·m	lb·pi	N·m
1/4 po	6	8	9	12
5/16 po	10	13	19	25
3/8 po	20	27	33	45
7/16 po	30	41	53	72
1/2 po	45	61	80	110
9/16 po	60	95	115	155
5/8 po	95	128	160	215
3/4 po	165	225	290	390
7/8 po	170	230	420	570
1 po	225	345	630	850

REMARQUE : Les catégories des boulons sont indiquées sur leur tête.

IMPORTANT! Les valeurs de couple de serrage indiquées dans le tableau s'appliquent aux filets non graissés et non huilés. Ne pas graisser ou huiler les filets, sauf mention contraire. Lorsque vous utilisez un enduit frein pour filets, augmentez la valeur de couple de 5%.

IMPORTANT! Si vous remplacez de la même catégorie, utilisez des fixations de la même catégorie.

Couple appliqué sur les boulons
 Vérification du couple appliqué sur les boulons
 Les tableaux figurant ci-dessous donnent les valeurs correctes de couple pour divers boulons et vis de blocage. Serrez tous les boulons selon le couple spécifié dans le tableau, sauf mention contraire. Vérifiez de temps à autre que les boulons sont bien serrés.

Pre-delivery Inspection	
Inspect for damage from shipping. Immediately contact the shipping company if damage is found.	
Three-point Hitch Wood Splitter	
Hydraulic Valve Control Function	
Hydraulic Cylinder Function	
All fasteners are Tight	
Hydraulic Connections are tight	
Safety Checks	
All Safety Decals Installed	
Guards and Shields Installed and Secured	
Review Operating and Safety Instructions	

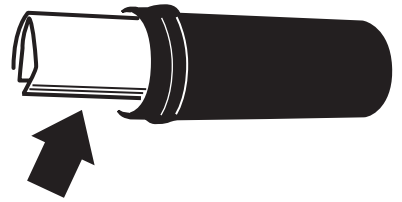

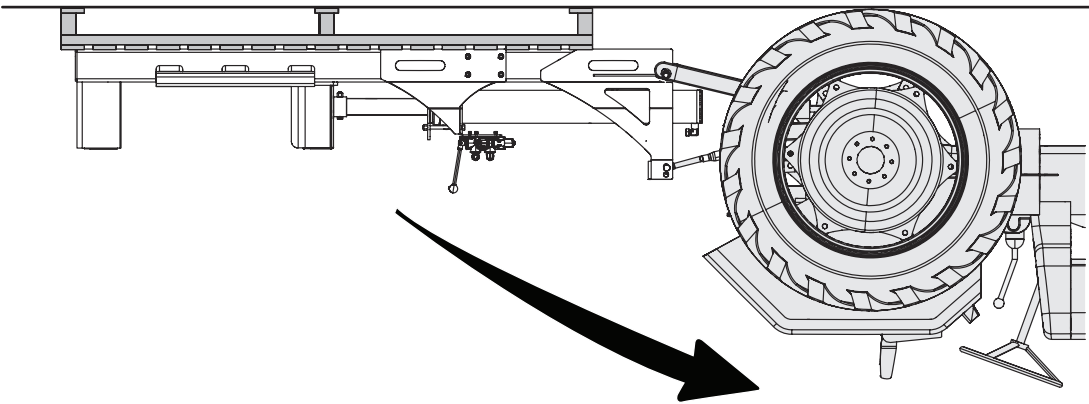
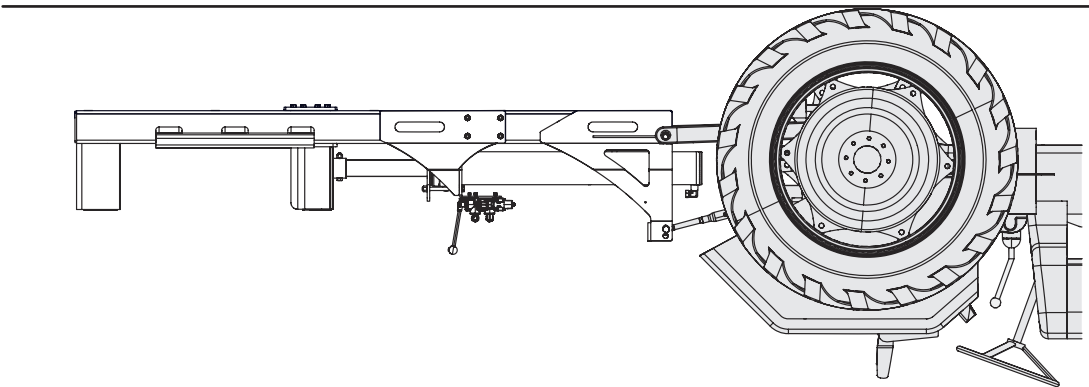

WX330

WX320

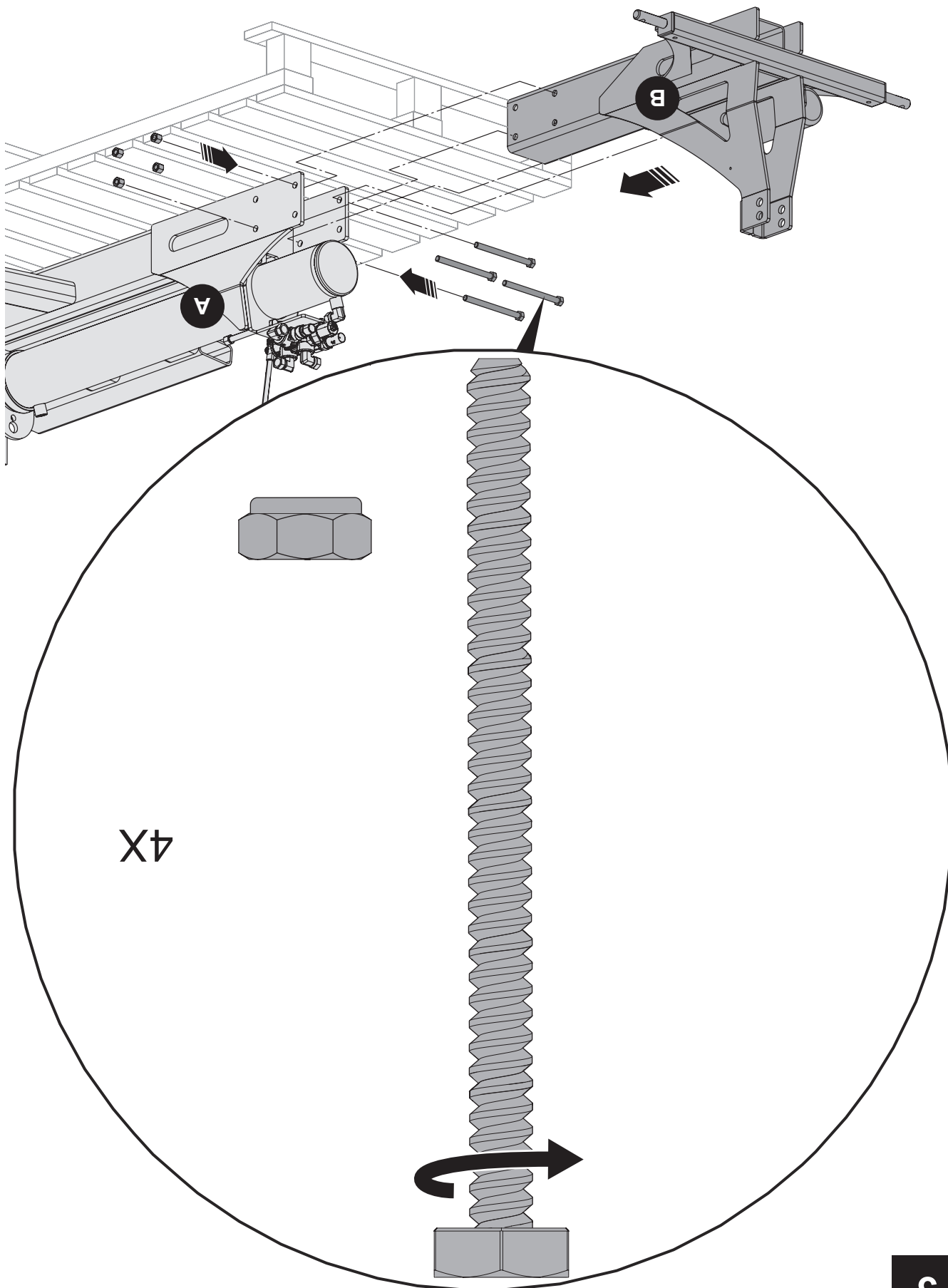

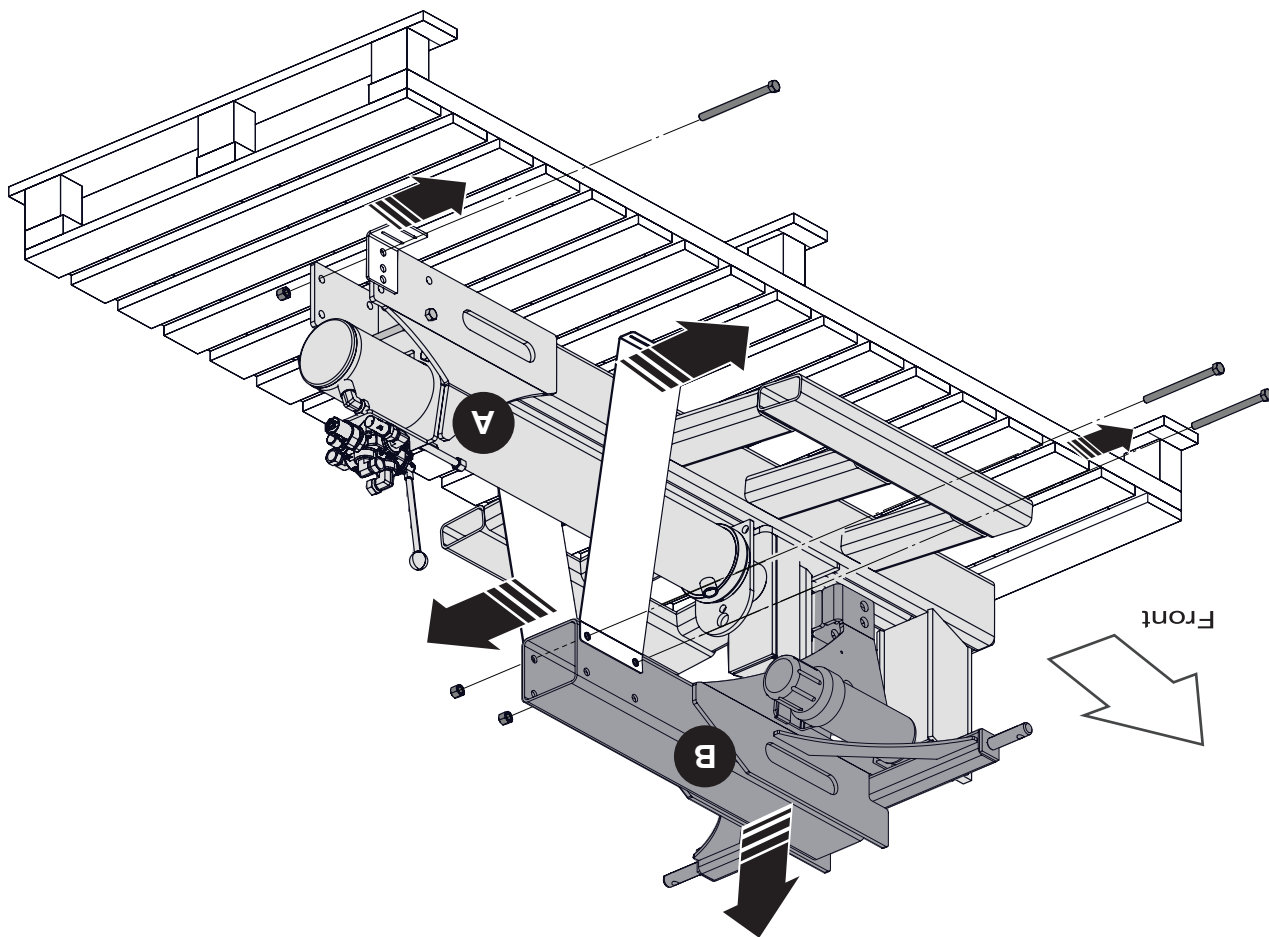
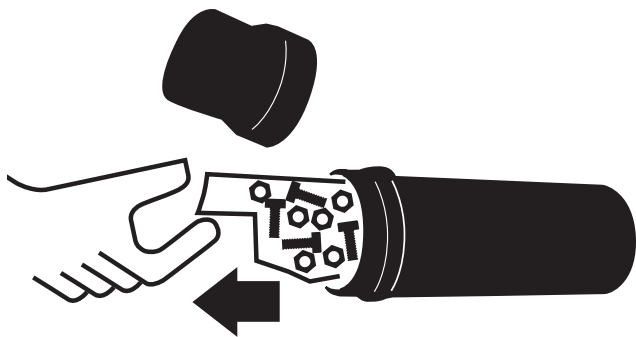

WX330

WX320

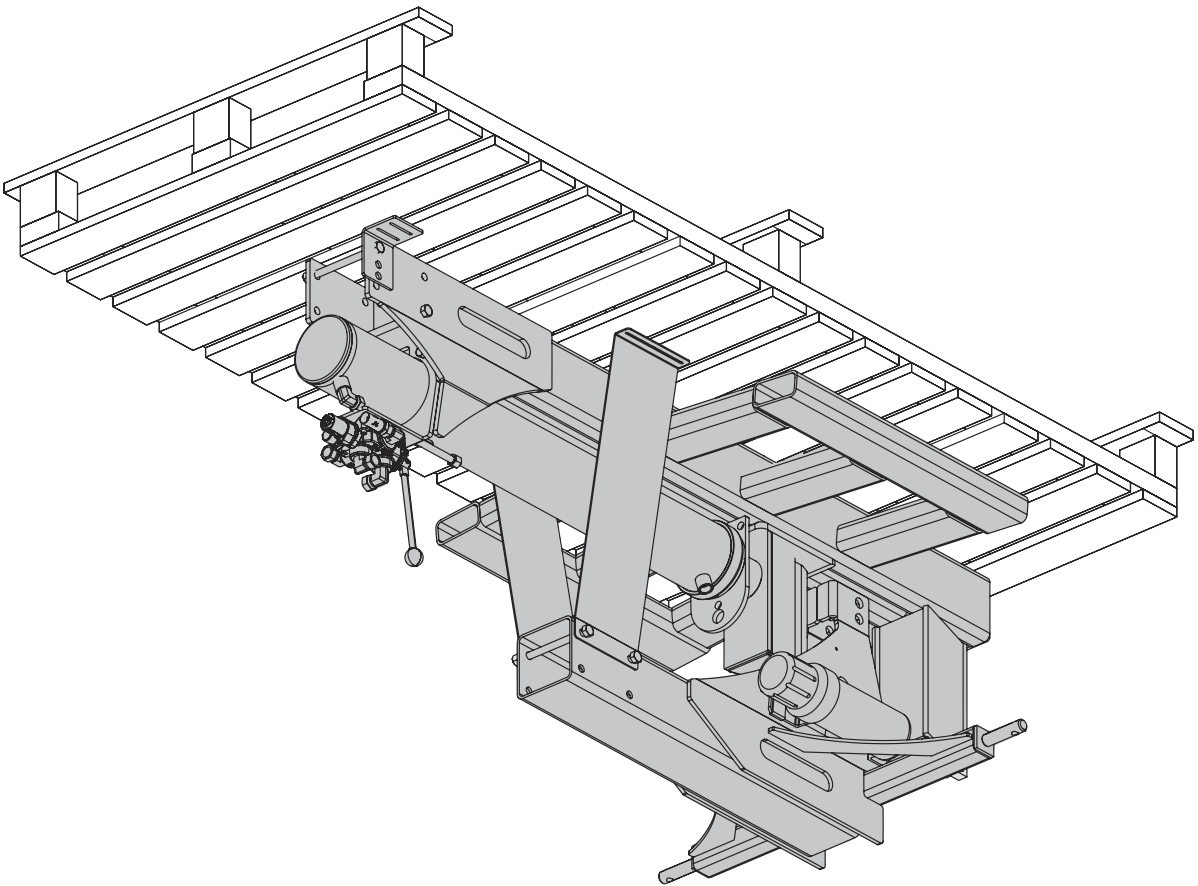

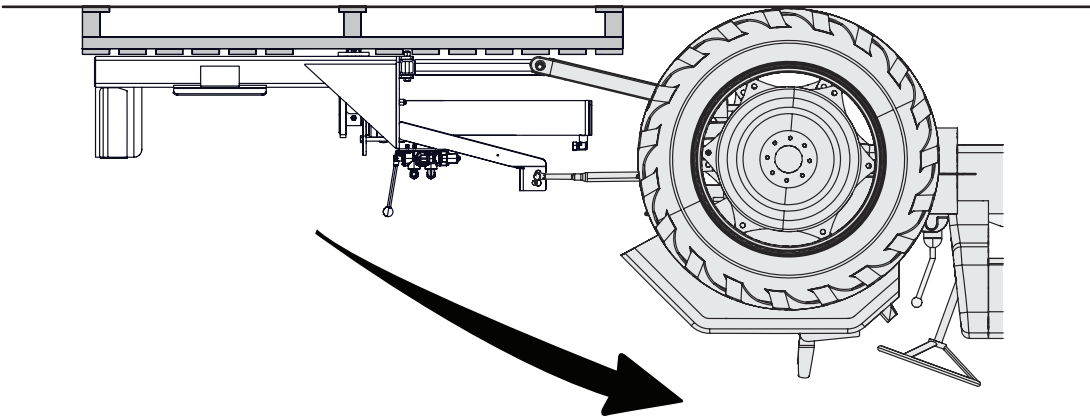
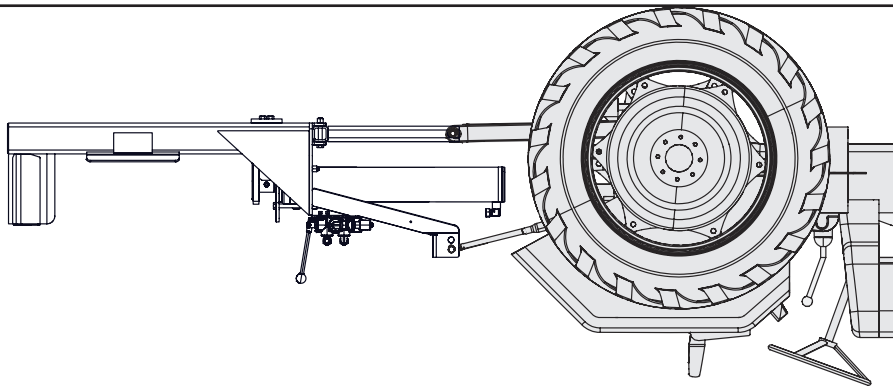

WX310

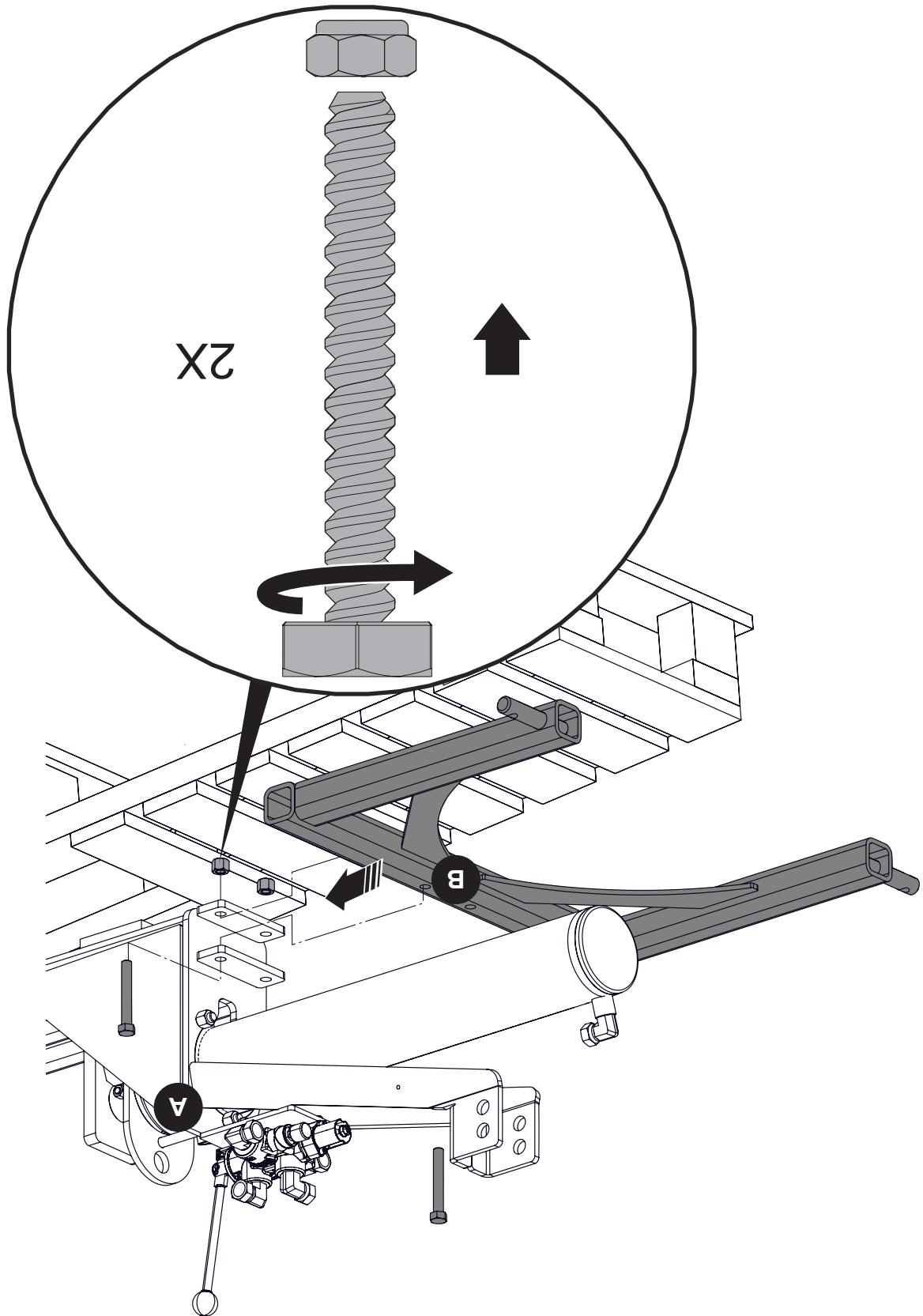

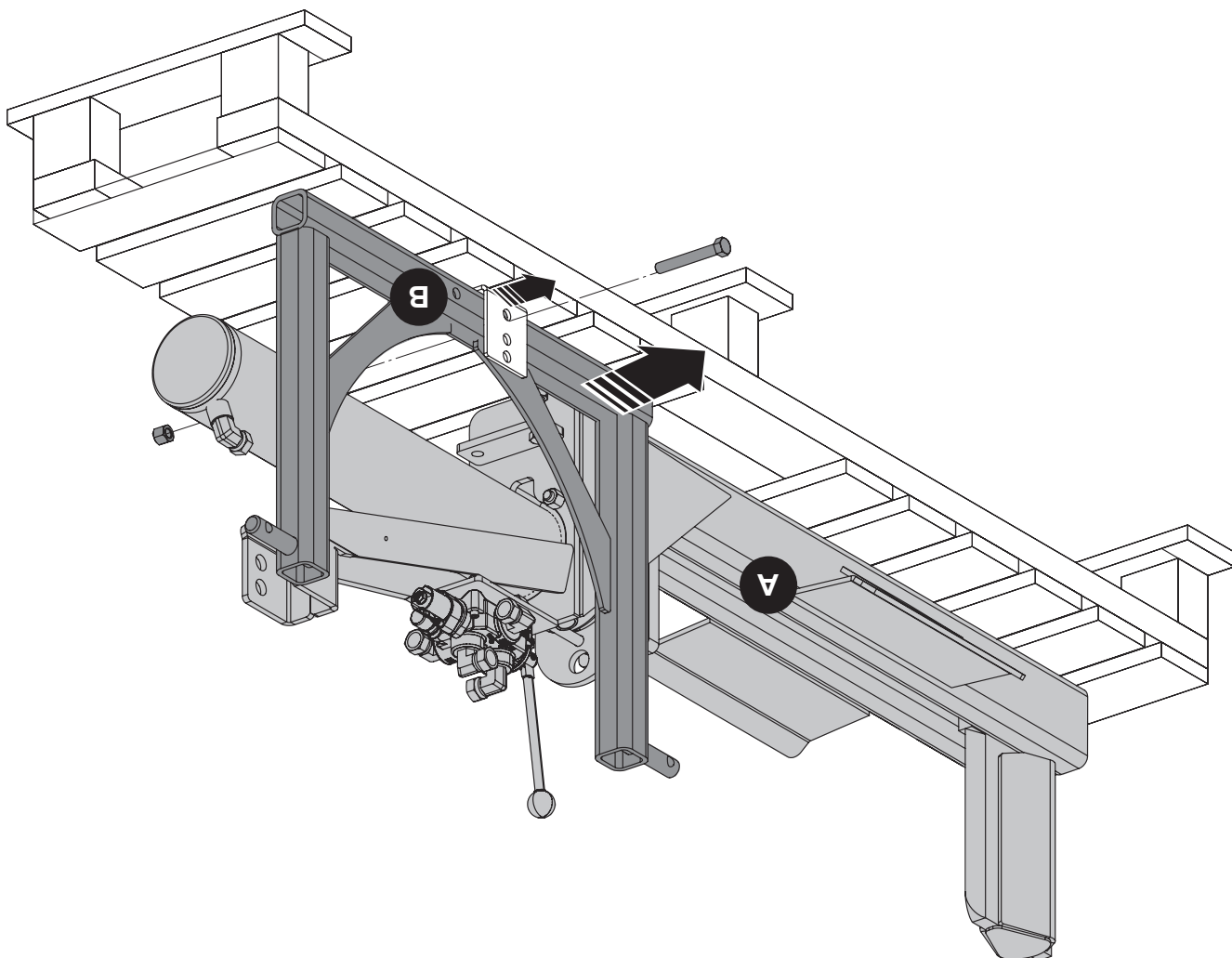
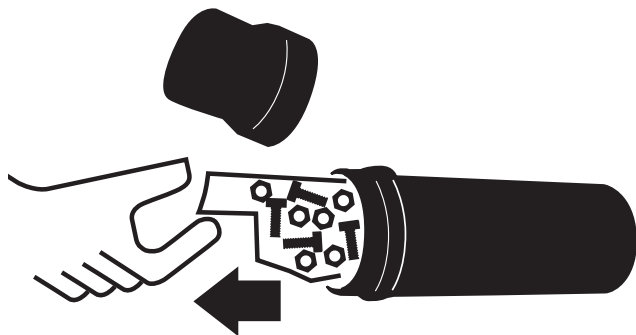

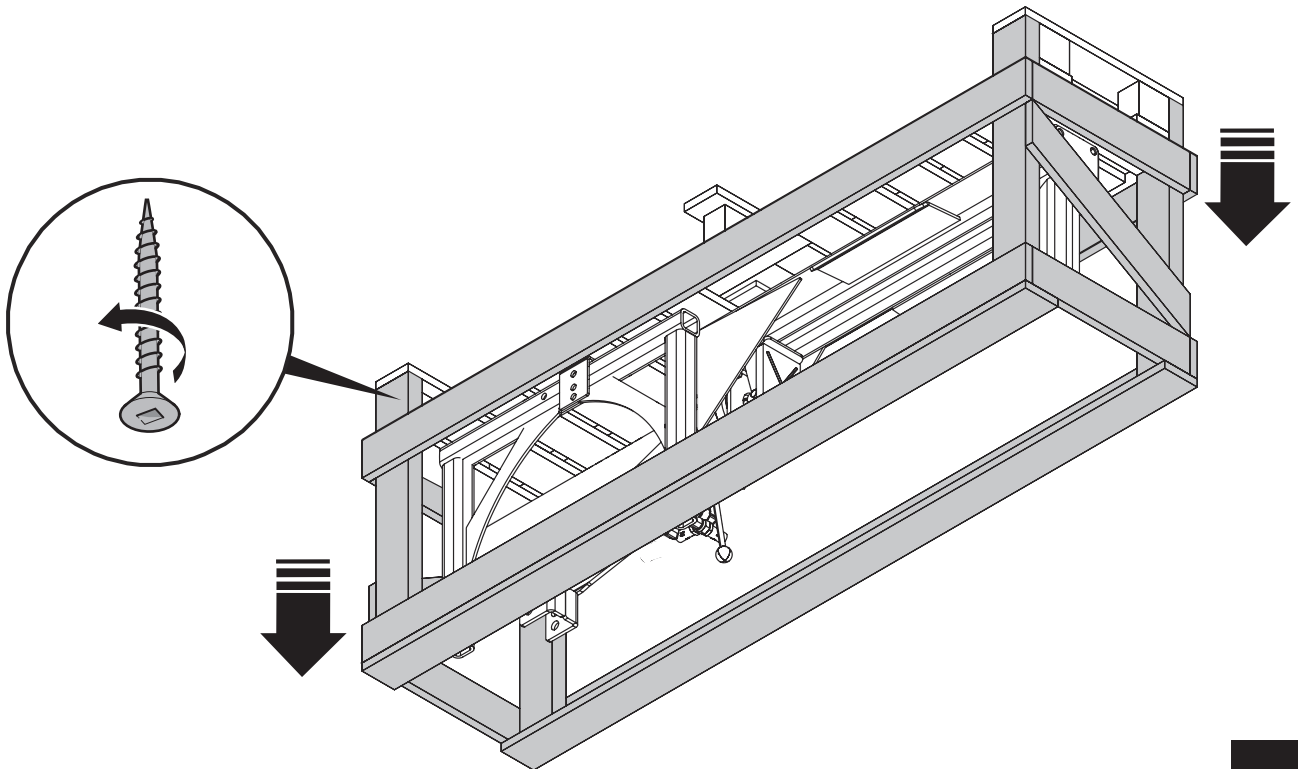

WX330

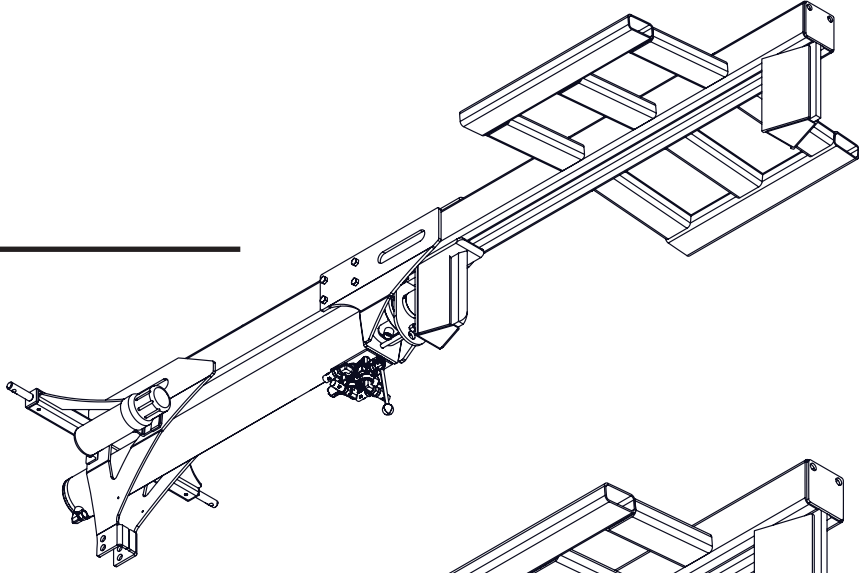

WX320

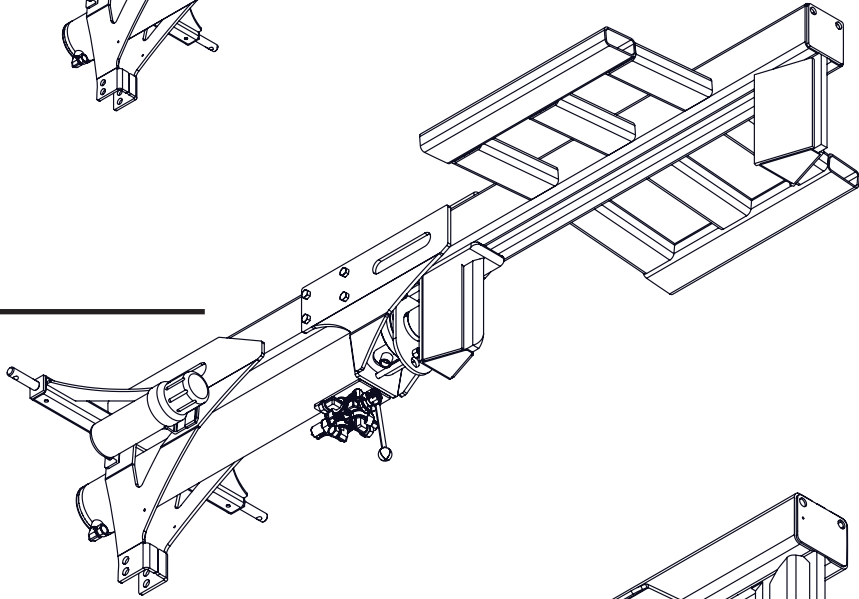

WX310

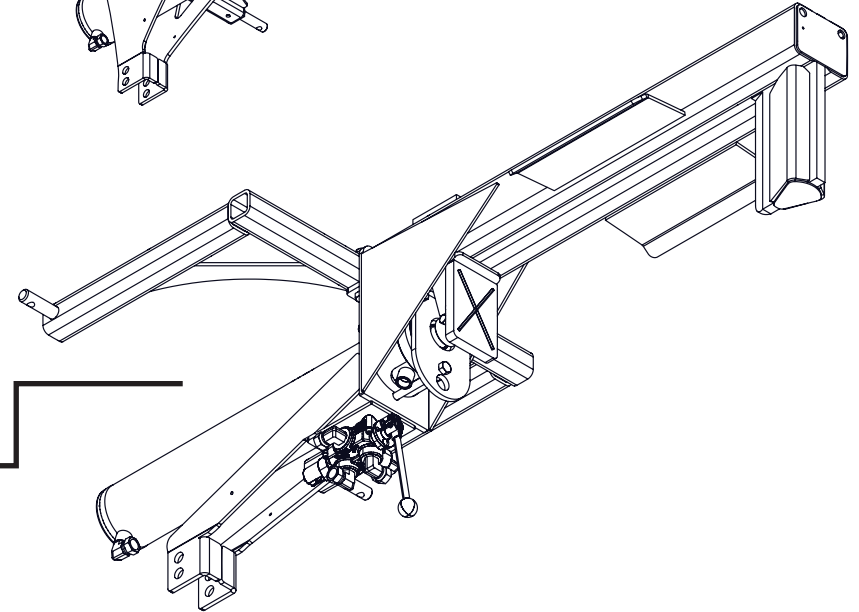

WX330

WX320

WX310

Évitez le risque de vous blesser ou d'endommager l'équipement! Lisez le guide de l'utilisateur avant d'utiliser l'équipement. Lisez attentivement tous les messages de sécurité dans le guide et observez tous les symboles de sécurité sur l'équipement.

AVERTISSEMENT!



IMPORTANT! Effectuez une inspection et soyez à l'affût de dommages résultant de la livraison, auquel cas veuillez communiquer sans délai avec la société de transport.

Remarque : Le dessus de la caisse ainsi que certaines pièces sont reliés au châssis mobile par des vis.

La quincaillerie d'assemblage se trouve à l'intérieur du tube manuel de l'utilisateur. Les supports d'expédition ne sont pas réutilisés.

La sécurité avant tout!

Lisez attentivement les directives d'assemblage avant de débuter. Assurez-vous de bien comprendre chacune des étapes avant de mettre en marche l'équipement. Familiarisez-vous avec tous les symboles de sécurité sur l'équipement ainsi que leur signification. Serrez tous les éléments de fixation selon les valeurs de couple spécifiées sur la page des spécifications du couple de serrage. Vérifiez à nouveau avant d'utiliser l'appareil.

AVERTISSEMENT!



Positionnez la caisse dans une grande zone ouverte offrant un accès de tous les côtés pendant l'assemblage. Restez à distance des lignes électriques aériennes et de tout obstacle lorsque vous soulevez l'équipement pendant son assemblage. Le contact avec un câble électrique peut causer une électrocution. Le contact avec un obstacle peut endommager les composants ou entraîner leur défaillance. Gardez la zone où se fait l'assemblage propre pour éviter tout débouchement ou glissement. Utilisez un treuil pour soulever les composants qui pèsent plus de 50 livres (23 kg) afin d'éviter des blessures au dos. Tous les dispositifs de levage (courroies, élingues, chaînes, poulies à cliquet) doivent être conformes aux certifications et aux règlements locaux applicables. Wallenstein Equipment Inc. ne peut assumer la responsabilité pour l'utilisation d'équipement et de pratiques de travail non conformes. Utilisez du matériel de levage ayant une capacité plus grande que le poids du composant. Placez les supports de sécurité ou les blocs de bois sous l'équipement afin de le stabiliser de façon sécuritaire avant d'y travailler pendant l'assemblage. Utilisez le bon outil pour accomplir le travail. Réparez ou remplacez les outils ou le matériel défectueux ou brisé. Les outils de fortune peuvent occasionner des risques à la sécurité. Un outil qui se brise ou qui vous glisse des mains pendant l'utilisation peut entraîner des blessures à l'utilisateur.



WX330
WX320
WX310

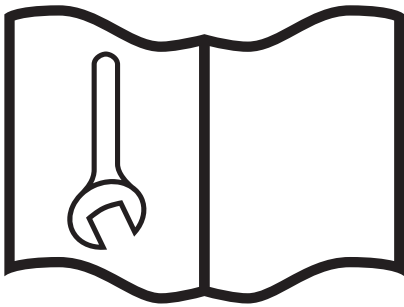

Directives d'assemblage