

OPERATOR'S MANUAL

WP240 / WP270 3-POINT HITCH FIREWOOD PROCESSOR

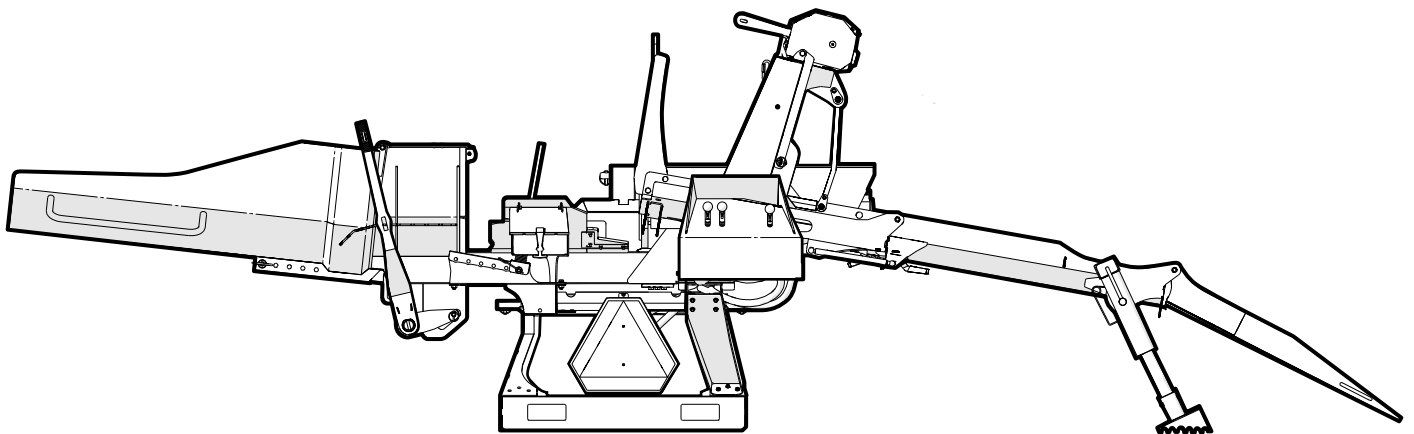

1. Foreword

1.1 Introduction

Congratulations on your choice of a Wallenstein Wood Processor to compliment your operation. This equipment has been designed and manufactured to meet the needs of a discerning timber or woodlot industry.

This manual covers the Wallenstein Wood Processor Model WP240 and WP270. The Wallenstein Firewood Processor improves firewood productivity, ergonomics and minimizes handling—all you have to do is cut. The Wallenstein Firewood Processor saves time and money while reducing the risk of physical strain.

Safe, efficient and trouble free operation of your Wallenstein Wood Processor requires that you and anyone else who will be using or maintaining the Wood Processor, read and understand the Safety, Operation, Maintenance and Trouble Shooting information contained within the Operator's Manual.

The WP240 is able to split 27" maximum length, while the WP270 is able to split 39" maximum length logs. See *Specifications on page 51* at the back of the manual for more detail.

Safe, efficient and trouble free operation of your Wallenstein Wood Processor requires that you and anyone else who will be using or maintaining the Wood Processor, read and understand the Safety, Operation, Maintenance and Trouble Shooting information contained within the Operator's Manual.

Keep this manual handy for frequent reference and to pass on to new operators or owners. Call your Wallenstein dealer or the Distributor if you need assistance, information or additional copies of the manuals.

Wallenstein Equipment Inc. • © 2019

WARNING!

Do not attempt to start or operate the machine without thoroughly reviewing this manual for safe and proper operation.

Always keep this manual with the machine.

W034



www.wallensteinequipment.com

Table of Contents

1. Foreword	2	5. Operation	33
1.1 Introduction	2	5.1 Be Prepared	33
1.2 Delivery Inspection Report.....	4	5.2 Starting.....	34
1.3 Serial Number Location.....	5	5.3 Stopping	34
1.4 Warranty.....	6	5.4 Emergency Stopping.....	34
1.5 Decal Information	7	5.5 Machine Set-Up	35
2. Safety	8	6. Processing Operation	38
2.1 Safety Alert Symbol.....	8	6.1 Winching	38
2.2 Why is SAFETY important?	8	6.2 Position the Log	39
2.3 Signal Words.....	8	6.3 Cutting.....	39
2.4 General	9	6.4 Splitting	40
2.5 Safety Do's and Don'ts.....	9	6.5 Next Log.....	40
2.6 Equipment Safety Guidelines.....	10	6.6 Last Log	41
2.7 Safety Training	11	6.7 Efficient Processing.....	41
2.8 Hydraulic System Safety	12	6.8 Pull Angle.....	41
2.9 Preparation.....	12	6.9 Wood Discharge.....	42
2.10 Operating Safety	13	7. Transporting	43
2.11 Transport Safety.....	14	8. Storage	44
2.12 Storage Safety	15	8.1 Placing Wood Processor in Storage	44
2.13 Maintenance Safety	15	8.2 Removing From Storage	44
2.14 Chainsaw Safety	15	9. Service and Maintenance	45
2.15 Wood Processing Safety.....	16	9.1 Fluids and Lubricants	45
2.16 Winching Safety	17	9.2 Greasing.....	46
2.17 Sign-Off Form.....	18	9.3 Service Illustration.....	47
2.18 Safety Signs	20	9.4 Maintenance Schedule	48
2.19 Safety Sign Explanations	21	9.5 Hydraulic System Oil and Filter Change (Optional Power Pack only).....	49
2.20 Replace Damaged Safety Signs	22	10. Trouble Shooting	50
2.21 How to Install Safety Signs	22	11. Specifications	51
3. Familiarization	22	11.1 Bolt Torque.....	52
3.1 To the New Operator.....	22	11.2 Hydraulic Fitting Torque	53
3.2 Safe Condition Procedure	22	12. Accessories	54
3.3 Operator Orientation	22	13. Alphabetical Index	55
3.4 Training	23		
3.5 Job Site Familiarization	23		
3.6 Equipment Condition.....	23		
3.7 Machine Components	23		
3.8 Machine Break-In.....	25		
3.9 Pre-Operation Checklist.....	25		
4. Controls	26		
4.1 Hydraulic Controls and Auto Cycle	26		
4.2 Hydraulic Winch Control.....	27		
4.3 Winch Gear Lever	27		
4.4 Splitting Wedge Height Lever	28		
4.5 Adjustable Log Length Guide.....	28		
4.6 Splitter Chute Height Adjuster.....	29		
4.7 Attaching / Unhooking	30		

1.2 Delivery Inspection Report

WALLENSTEIN
WP240 / WP270 Trailer Wood Processor
 To activate warranty, register your product online at
<http://www.wallensteinequipment.com>

This form must be filled out by the dealer and signed by both the dealer and the customer at the time of delivery.

Customer's Name _____

Contact Name _____

Dealer Name _____

(_____) _____
 Phone Number

Serial Number _____

_____/_____/_____
 Delivery Date (dd/mm/yy)

I have thoroughly instructed the buyer on the equipment care, adjustments, safe operation and applicable warranty policy and reviewed the manuals.

Dealer's Rep. Signature _____

_____/_____/_____
 Delivery Date (dd/mm/yy)

The product manuals have been received by me and I have been thoroughly instructed as to care, adjustments, safe operation and applicable warranty policy.

Owner's Signature _____

_____/_____/_____
 Delivery Date (dd/mm/yy)

<input checked="" type="checkbox"/>	Pre-delivery Inspection
Inspect for damage from shipping. Immediately contact the shipping company if damage is found.	
Wood Processor	
<input type="checkbox"/>	Hydraulic Splitter Controls Function
<input type="checkbox"/>	Hydraulic Cylinder Functions
<input type="checkbox"/>	Splitter Chute Folds Up
<input type="checkbox"/>	Wedge Height Adjuster Functions
<input type="checkbox"/>	Loader and Lead-in Chutes Fold Up and Latch Securely
<input type="checkbox"/>	Log Stabilizer Moves Freely
<input type="checkbox"/>	Fasteners Tight
<input type="checkbox"/>	Grease Zerks / Lubricate Pivot Points
<input type="checkbox"/>	Pivot Tongue Moves Freely
<input type="checkbox"/>	Hydraulic Connections
<input type="checkbox"/>	Review Operating and Safety Instructions
Safety Checks	
<input type="checkbox"/>	All Safety Decals Installed
<input type="checkbox"/>	Guards and Shields Installed and Secured
<input type="checkbox"/>	All Jacks Function
<input type="checkbox"/>	Retainer Installed Through Hitch Points
<input type="checkbox"/>	Review Operating and Safety Instructions
Hydraulic Winch	
<input type="checkbox"/>	Check Winch Clutch Handle Control
<input type="checkbox"/>	Check Winch Rope / Hook / Fairlead
<input type="checkbox"/>	Check Hydraulic Function
<input type="checkbox"/>	Review Operating and Safety Instructions
Optional Equipment	
<input type="checkbox"/>	Chain Saw Holster: Installed securely
<input type="checkbox"/>	6 Way Wedge: Check Height Adjuster
<input type="checkbox"/>	Chainsaw Pivot: Check Pivot Function

1.3 Serial Number Location

Always give your dealer the serial number of your Wallenstein Wood Processor when ordering parts or requesting service or other information.

The Serial Number Plate location is shown in the illustration. Please record the product serial number in the space provided below for easy reference.

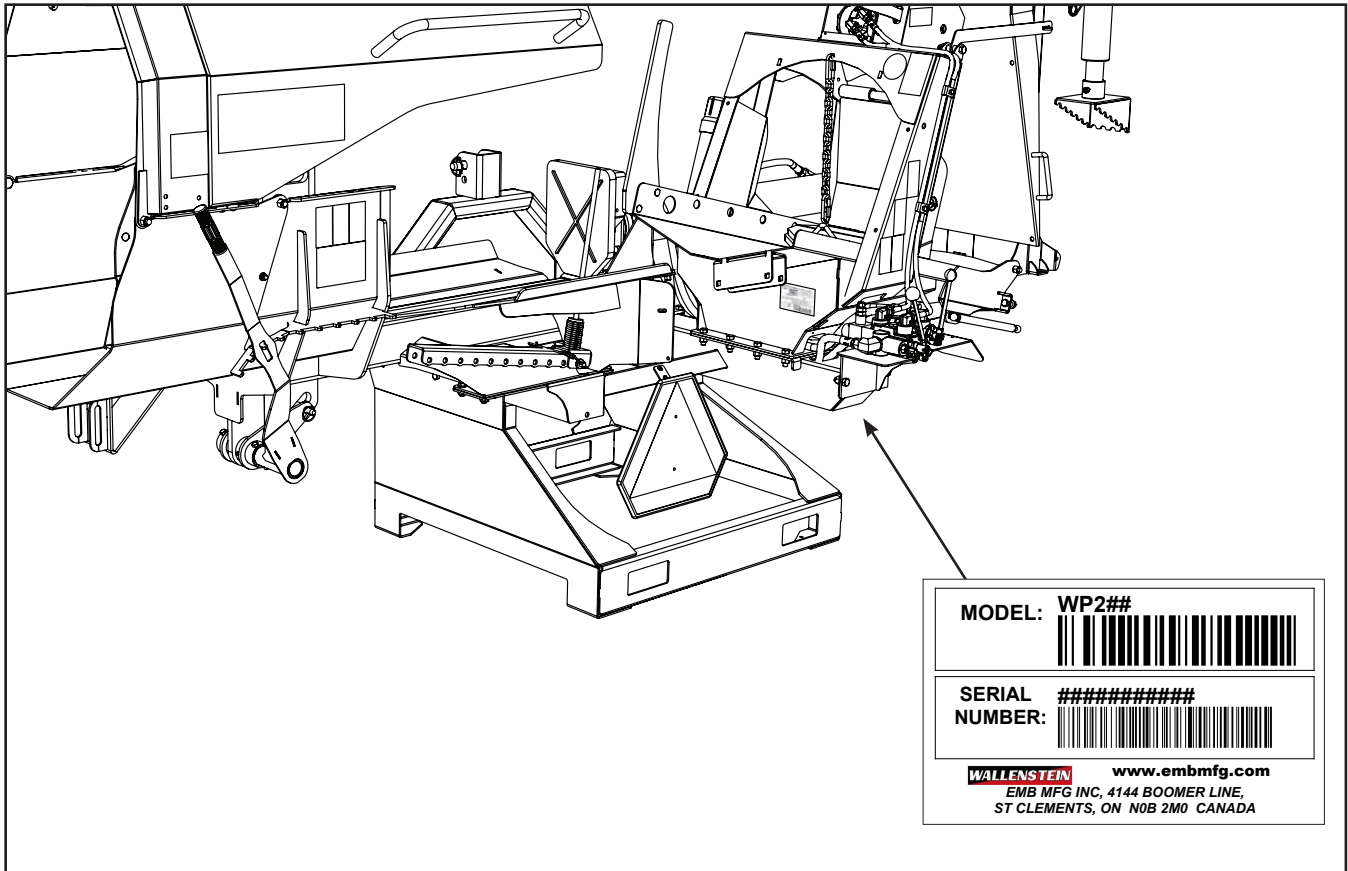

Fig. 1 – Serial Number Plate Location (Typical)

Record Product Information Here	
Model:	
Serial Number:	

1.4 Warranty



LIMITED WARRANTY

Wallenstein products are warranted to be free of defects in materials and workmanship under normal use and service, for a period of

Five Years for Consumer Use

Two Years for Commercial/Rental Use

from the date of purchase, when operated and maintained in accordance with the operating and maintenance instructions supplied with the unit. Warranty is limited to the repair of the product and/or replacement of parts.

This warranty is extended only to the original purchaser and is not transferable.

Repairs must be done by an authorized dealer. Products will be returned to the dealer at the customer's expense. Include the original purchase receipt with any claim.

This warranty does not cover the following:

- 1) Normal maintenance or adjustments
- 2) Normal replacement of wearable and service parts
- 3) Consequential damage, indirect damage, or loss of profits
- 4) Damages resulting from:
 - Misuse, negligence, accident, theft or fire
 - Use of improper or insufficient fuel, fluids or lubricants
 - Use of parts or aftermarket accessories other than genuine Wallenstein parts
 - Modifications, alteration, tampering or improper repair performed by parties other than an authorized dealer
 - Any device or accessories installed by parties other than an authorized dealer
- 5) Engines. Engines are covered by the manufacturer of the engine for the warranty period they specify. For the details of your engine warranty, see your engine owner's manual. Information about engine warranty and service is also available in the FAQ section at www.wallensteinequipment.com

1.5 Decal Information

When getting familiar with the Wallenstein product, notice that there are numerous decals located on the machine. There are different types of decals for safety, information, and product identification. The following section explains what they are for and how to read them.

Safety Decals are pictorial with a yellow background and generally two panel. The top panel shows the safety alert (the potential hazard) and the bottom panel shows the message (how to avoid the hazard).

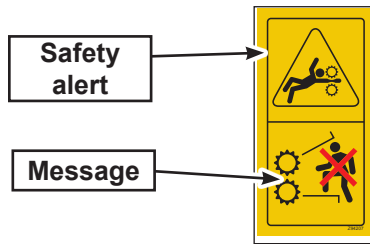

Safety Notice Decals are pictorial with a blue background and generally rectangular with single or multiple symbols. This decal informs what Personal Protective Equipment is required for safe operation.



Informative Decals are generally pictorial with a white background and can vary in the number of panels. This type of decal explains how a control works.

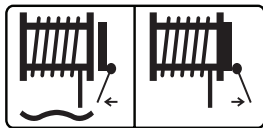

Product Decals indicate machine model and serial number, and other important information.

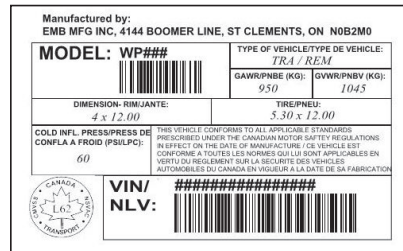

Maintenance Decals have a green background and can vary to the number of panels. This decal shows a type maintenance required and frequency interval.



See the section on safety signs for safety decal definitions. For a complete illustration of decals and decal locations, download the parts manual for your model product at www.wallensteinequipment.com.

2. Safety

2.1 Safety Alert Symbol

This Safety Alert Symbol means:

**ATTENTION! BE ALERT!
YOUR SAFETY IS INVOLVED!**



The **Safety Alert Symbol** identifies important safety messages on the Wallenstein Wood Processor and in the manual. When you see this symbol, be alert to the possibility of personal injury or death. Follow the instructions in the safety message.

2.2 Why is SAFETY important?

Three Big Reasons:

- Accidents Disable and Kill
- Accidents Cost
- Accidents Can Be Avoided

2.3 Signal Words

The signal words **DANGER**, **WARNING** and **CAUTION** determine the seriousness level of the warning messages in this manual. The appropriate signal word for each message in this manual has been selected using the following guidelines:

DANGER –

Indicates an imminently hazardous situation that, if not avoided, **will** result in death or serious injury. This signal word is to be limited to the most extreme situations typically for machine components which, for functional purposes, cannot be guarded.

WARNING –

Indicates a potentially hazardous situation that, if not avoided, **could** result in death or serious injury, and includes hazards that are exposed when guards are removed. It may also be used to alert against unsafe practices.

CAUTION –

Indicates a potentially hazardous situation that, if not avoided, **may** result in minor or moderate injury. It may also be used to alert against unsafe practices.

IMPORTANT – To avoid confusing equipment protection with personal safety messages, a signal word **IMPORTANT** indicates a situation that if not avoided, could result in damage to the machine.



NOTE: *(plus text) – indicates an additional explanation for an element of information.*

If there are any questions not answered in this manual, you require additional copies or the manual is damaged, please contact your dealer or Wallenstein at 4144 Boomer Line, St. Clements, ON, N0B 2M0 Phone (519) 699-9283 or Fax (519) 699-4146.

2.4 General

YOU are responsible for the SAFE operation and maintenance of your Wallenstein Trailer Wood Processor. **YOU** must ensure that you and anyone else who is going to use, maintain or work around the Wood Processor be familiar with the operating and maintenance procedures and related **SAFETY** information contained in this manual. This manual will take you step-by-step through your working day and alerts you to all good safety practices that should be used while using your Wallenstein Trailer Wood Processor.

Remember, **YOU** are the key to safety. Good safety practices not only protect you but also the people around you. Make these practices a working part of your safety program. Be certain that **EVERYONE** using this equipment is familiar with the recommended operating and maintenance procedures and follows all the safety precautions. Most accidents can be prevented.

Do not risk injury or death by ignoring good safety practices.

2.5 Safety Do's and Don'ts

- **DO** give operating instructions to operators or employees before allowing them to operate the machine, and **REVIEW** annually thereafter.
- **DO** read and understand ALL Safety and Operating instructions in the manual and follow them. Most accidents can be avoided. The most important safety device on this equipment is a **SAFE** operator.
- **DO** review safety related items annually with all personnel who will be operating or performing maintenance .



- **DO** wear appropriate Personal Protective Equipment (PPE). This equipment includes but is not limited to the following:



- A hard hat
- Heavy gloves
- Hearing protection
- Protective shoes with slip resistant soles
- Protective glasses, goggles or face shield

- **DO** set the machine in a Safe Condition before performing any service, maintenance work, storage preparation, or hooking up. **Safe Condition** involves performing the following:

- Clear splitting chamber
- Wind in winch cable
- Shut off hydraulics
- Ensure all components have stopped moving
- Shut off the engine
- Remove and pocket the ignition key
- Ensure the wheels are chocked to prevent movement

- **DO** have a first-aid kit available for use should the need arise and know how to use it.



- **DO** read and understand all safety signs located on the machine before using, maintaining, adjusting or cleaning the grapple.
- **DO** inspect and secure all guards before starting.
- **DO** check cables, chains and chutes, that they are clear of debris prior to starting the machine.

- **DO** have a fire extinguisher available for use should the need arise and know how to use it.



- **DO** think SAFETY! Work SAFELY!
- **DO NOT** touch hot engine parts, muffler cover, hoses, engine body, engine oil, etc. during operation and after the engine has been shut off. Contact may cause burns.
- **DO NOT** expect a person who has not read and understood all use and safety instructions to operate the machine. An untrained operator is not qualified and exposes himself and bystanders to possible serious injury or death. It is the owners responsibility to the operator to ensure familiarity and understanding of the machine.
- **DO NOT** modify the equipment in any way. Unauthorized modification may impair the function and/or safety and could affect the life of the equipment.
- **DO NOT** allow riders during transport.
- **DO NOT** risk injury or death by ignoring good safety practices.

2.6 Equipment Safety Guidelines

Safety of the operator and bystanders is one of the main concerns in designing and developing equipment. However, every year many accidents occur which could have been avoided by a few seconds of thought and a more careful approach to handling equipment. You, the operator, can avoid many accidents by observing the following precautions in this section. To avoid personal injury or death, study the following precautions and insist those working with you, or for you to follow them.

In order to provide a better view, certain photographs or illustrations in this manual may show an assembly with a safety shield removed. However, equipment should never be used in this condition. Keep all shields in place. If shield removal becomes necessary for repairs, replace the shield prior to use.

1. Replace any safety sign or instruction sign that is not readable or is missing. Location of such safety signs is indicated in this manual.
2. Never use alcoholic beverages or drugs which can hinder alertness or coordination while using this equipment. Consult your doctor about using this machine while taking prescription medications.
3. **Under no circumstances should young children be allowed to work with this equipment. Do not allow persons to use or assemble this unit until they have read this manual and have developed a thorough understanding of the safety precautions and of how it works.** Review the safety instructions with all users annually.
4. This equipment is dangerous to children and persons unfamiliar with its operation. The operator should be a responsible, properly trained and physically able person familiar with machinery and trained in this equipment's operations. If the elderly are assisting with work, their physical limitations need to be recognized and accommodated.
5. Do not modify the equipment in any way. Unauthorized modification may result in serious injury or death and may impair the function and life of the equipment.

6. In addition to the design and configuration of this implement, including Safety Signs and Safety Equipment, hazard control and accident prevention are dependent upon the awareness, concern, prudence, and proper training of personnel involved in the operation, transport, maintenance, and storage of the machine.
7. When operating this equipment it is recommended to have at least 2 operators present and trained in safe operation of the machine. All operators must be completely familiar with all components of the machine and their function. **Never allow the machine to be operated by a lone operator!**
8. Never exceed the limits of a piece of machinery. If its ability to do a job, or to do so safely is in question – **DO NOT TRY IT.**
9. Place the machine in a Safe Condition before performing any service, maintenance work or storage preparation.

Safe Condition involves the following:

- Clear splitting chamber
- Wind in winch cable
- Shut off hydraulics
- Ensure all components have stopped moving
- Shut off the engine
- Remove and pocket the ignition key
- Ensure the wheels are chocked to prevent movement

2.7 Safety Training

1. Safety is a primary concern in the design and manufacture of our products. Unfortunately, our efforts to provide safe equipment can be wiped out by a single careless act of an operator or bystander.
2. The best safety feature is an informed, careful operator—we ask you to be that kind of an operator. It is the operator's responsibility to read, understand and follow ALL safety and operation instructions in the manual. Accidents can be avoided.
3. Working with unfamiliar equipment can lead to careless injuries. Read this manual before assembly or using the machine to acquaint yourself with it. If this machine is used by any person other than yourself, or is loaned or rented, it is the machine owner's responsibility to make



certain that prior to using, the operator:

- reads and understands the owner's manual
 - is instructed in safe and proper use of the equipment
 - understands and knows how to perform the Safe Condition procedure
4. Train all new personnel and review instructions frequently with existing workers. Be certain only a properly trained and physically able person will use the machinery. A person who has not read and understood all use and safety instructions is not qualified to use the machine. An untrained operator exposes himself and bystanders to possible serious injury or death. If the elderly are assisting with the work, their physical limitations need to be recognized and accommodated.
 5. Know your controls and how to stop the machine quickly in an emergency. Read this manual thoroughly.

2.8 Hydraulic System Safety

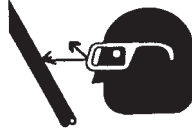
1. Make sure that all the components in the hydraulic system are kept in good condition and are clean.
2. Before applying pressure to the system, make sure all components are tight, and that lines, hoses and couplings are not damaged. 
3. Do not attempt any makeshift repairs to the hydraulic lines, fittings or hoses by using tapes, clamps or cements. The hydraulic system operates under extremely high pressure. Such repairs will fail suddenly and create a hazardous and unsafe condition.
4. Wear proper hand and eye protection when searching for a high pressure hydraulic leak. Use a piece of wood or cardboard as a backstop instead of hands to isolate and identify a leak. 
5. If injured by a concentrated high-pressure stream of hydraulic fluid, seek medical attention immediately. Serious infection or toxic reaction can develop from hydraulic fluid piercing the skin surface.
6. Relieve pressure on hydraulic system before maintaining or working on system.

2.9 Preparation

1. Never use the machine until the operators have been adequately trained in the safe operation of the machine and have read and completely understand:
 - safety, operation and feature sections of this manual
 - each of the safety messages found on the safety signs on the machine.
 - engine operator's manual
2. PPE is recommended during assembly, installation, operation, adjustment, maintaining, repairing, removal, cleaning, or moving the trailer. Do not allow long hair, loose fitting clothing or jewelry around equipment.
3. **Prolonged exposure to loud noise may cause permanent hearing loss!** Power equipment with or without equipment attached can often be noisy enough to cause permanent, partial hearing loss. We recommend that you wear hearing protection on a full-time basis if the noise in the Operator's position exceeds 80 dB. Noise over 85 dB on a long-term basis can cause severe hearing loss. Noise over 90 dB adjacent to the Operator over a long-term basis may cause permanent, total hearing loss. 

WARNING!

Hearing loss from loud noise (from engines, chainsaws, radios, and other such sources close to the ear) is cumulative over a lifetime, without hope of natural recovery.

4. When there are two or more operators, review and understand a system of hand signals.
5. Keep bystanders away at a safe distance at least 20 ft (6 m) from stacking zone. Mark the zone with safety cones.
6. Determine where chips will be piled and ensure it does not interfere with safe operation of the machine

7. Determine a safe work area / trailer location:
 - area must be clear of stones, branches or hidden obstacles that might cause a tripping, hooking or snagging hazard.
 - ground should be firm and level.
8. Be aware of overhead hazards: branches, cables, electrical wires.
9. Determine a safe split stack location:
 - Stack should be on level ground.
 - Ensure stack location does not interfere with safe operation of the machine.
10. Precut and de-limb material so that it is ready to load into the trailer.
11. Use only in daylight or good artificial light.
12. Be sure machine is properly stationed, adjusted and in good operating condition.
13. Ensure that all safety shielding and safety signs are properly installed and in good condition.
14. If fuel is on site, store it well away from the material pile .
15. Perform the **Pre-operation Checklist** procedure before starting work (see *Pre-Operation Checklist on page 25*).

2.10 Operating Safety

Please remember it is important that you read and heed the safety signs on the Wood Processor. Clean or replace all safety signs if they cannot be clearly read and understood. They are there for your safety, as well as the safety of others. The safe use of this machine is strictly up to you, the operator.

All things with moving parts are potentially hazardous. There is no substitute for a cautious, safe-minded operator who recognizes potential hazards and follows reasonable safety practices. The manufacturer has designed this Wood Processor to be used with all its safety equipment properly attached, to minimize the chance of accidents. Study this manual to make sure you have all safety equipment attached.

1. When operating this equipment always have at least two workers present and trained in safe operation of the machine. **Never allow the machine to be operated by a lone operator!**
2. It is recommended to have one operator and one spotter. The operator and spotter must be completely familiar with all components of the machine and their function.
3. **The operator must be in control of the machine at all times. The spotter must remain out of the danger zone while the machine is in operation. Bystanders must remain in the safe zone**
4. Close and secure all guards, deflectors and shields before starting and operating. If guard is removed, replace it.
5. Read and understand owner's manual before starting. Review safety instructions annually.
6. Personal protective equipment is recommended during assembly, installation, operation, adjustment, maintaining, repairing, removal, or moving. Do not allow long hair, loose-fitting clothing, or jewelry to be around moving parts.
7. Do not allow anyone within the work or danger zone machine or logs during operation. Wood chips can be ejected and injure others. Keep children away
8. Before servicing, repairing or maintaining the machine, perform the **Safe Condition** procedure. See *Safe Condition on page 22*.

9. Do not try to process more than one log at a time. The extra log can move unexpectedly and cause injury.
10. Use a peavey or other tool to reposition logs in the splitting chamber.
11. Keep your fingers and hands away from cracks in the log that can open or close while splitting.
12. Handle logs using a peavey for positioning.
13. Always handle split wood by holding onto the sides, not ends or the top and bottom.
14. Do not load the splitting cradle while the wedge is in motion.
15. Do not try to split logs across the grain. Some logs can burst or splinter and fly out of the machine causing injury.
16. For unevenly cut logs, always place the wide side down and the most square end against the splitting wedge.
17. Never stand directly in line with rope while winching.
18. Operators should never use alcoholic beverages or drugs which can hinder alertness or coordination while operating this equipment. Consult your doctor about operating this machine while taking prescription medications.
19. Operate only on level ground.
20. Do not operate on hillsides or when working area is cluttered, wet, muddy or icy to prevent slipping and tripping.
21. Position machine so prevailing winds blow engine exhaust fumes away from operator's station.
22. Keep working area clean and free of debris to prevent tripping. Operate only on level ground.
23. Stop engine when leaving the machine unattended.

2.11 Transport Safety

1. Comply with Provincial / state and local laws governing safety and transporting of machinery on public roads.
2. Do not exceed a safe travel speed. Slow down for rough terrain and cornering.
3. Fold up and secure the in-feed and splitter chute and before moving or transporting.
4. Ensure all latch handles are secure.
5. Ensure the stability jacks are in the up position and secured with the latch pin.
6. Inspect all access panels and guards to ensure they are secured.
7. Clean off all debris from the machine.
8. Check that all the lights, reflectors and other lighting requirements are installed and in good working condition.
9. Never allow riders on the machine.
10. Be a safe and courteous driver. Always yield to oncoming traffic in all situations, including narrow bridges, intersections, and so on.
11. Watch for traffic when near or crossing roadways.
12. Do not drink and drive.
13. Just before transport, perform a circle check to ensure everything is safe.
14. Do not exceed a safe travel speed when transporting.

2.12 Storage Safety

1. Store the unit in an area away from human activity.
2. Do not let children to play on or around the stored machine.
3. Store the unit in a dry, level area. Support the frame with planks if required.

2.13 Maintenance Safety

1. Good maintenance is your responsibility. Poor maintenance is an invitation to trouble.

2. Follow good shop practices:

- Keep service area clean and dry.
- Be sure electrical outlets and tools are properly grounded.
- Use adequate light for the job at hand.



3. Make sure there is plenty of ventilation. Never operate the machine or the towing vehicle in a closed building. The exhaust fumes may cause asphyxiation.
4. Before servicing or repairing, perform the **Safe Condition** procedure. See page 22.
5. Allow the engine to cool before performing maintenance, engine components and oil may be hot enough to cause injury.
6. Never work under equipment unless it is blocked securely.
7. When performing any service or maintenance work always use personal protection devices
8. Where replacement parts are necessary for periodic maintenance and servicing, genuine factory replacement parts must be used to restore your equipment to original specifications. The manufacturer will not be responsible for injuries or damages caused by use of unapproved parts and/or accessories.
9. A fire extinguisher and first aid kit should be kept readily accessible while performing maintenance on this equipment.
10. Inspect and tighten all bolts, nuts and screws and check that all electrical and fuel connections are properly secured to ensure machine is in a safe working condition.

11. When completing a maintenance or service function, make sure all safety shields and devices are installed before placing machine in service.
12. When performing maintenance on this equipment always have at least 2 workers present. Do not work alone in case an emergency should arise.
13. A When cleaning any parts, do not use gasoline but use regular cleanser.
14. Always use proper tools, that are in good condition. Make sure you understand how to use them, before performing any service work.

2.14 Chainsaw Safety

Please review the safety guidelines in the manual included with your chainsaw. Here are some general tips when using a chainsaw:

1. Only use chainsaws that you have been trained to use properly and safely.
2. Make sure you understand instructions before attempting to use any chainsaw.
3. Operate, adjust and maintain saws according to the manufacturers' directions
4. Wear personal protective equipment and clothing recommended by the chainsaw manufacturer.
5. Ask questions if you have any doubts about doing the work safely.
6. Only operate saws when you are well rested. Fatigue causes carelessness.
7. Have all required supplies and equipment with you before you start the work.
8. Be aware of your surroundings, weather conditions, terrain, buildings, power lines, vehicles, and other people.

2.15 Wood Processing Safety

The WP200 Series Wood Processors are designed to winch, cut to length and split logs for firewood. Review and follow safe operating and winching safety instructions in this manual. Also review the safety guidelines included with your chainsaw.

Below is an example of a safe work area. Not all work areas are the same, but the principles presented here can be applied to any work area.

The safe work area is divided into four zones:

Safe Zone – Bystanders or any one not directly involved with the work are allowed - outside of the work / danger zone, minimized hazards.

Work Zone – Workers helping the operator and wearing the appropriate PPE are allowed - outside of the danger zone, limited hazards.

Danger Zone – Workers / bystanders should always make eye contact with the operator before entering the danger zone. Unauthorized Workers / bystanders are not allowed in the danger zone. Hazards are present.

Operator Zone – Only the operator should be in the operator work zone, do not operate the machine outside of the operator zone.

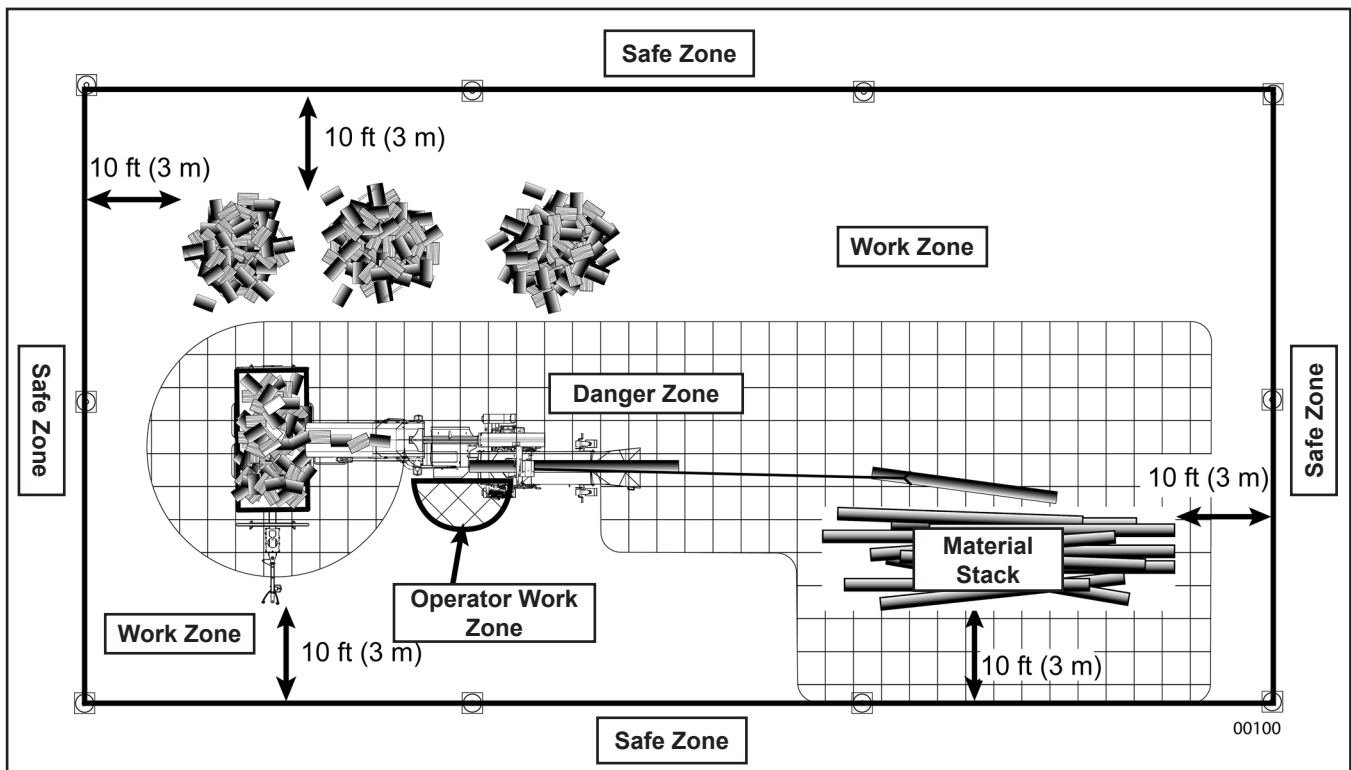

Fig. 2–Safe Work Area

Injury can occur from:

- material falling or rolling off a stack
- flying wood chips
- pinching hazard if bystanders are inside the work or danger zone.

Follow these important points to keep bystanders, operators and workers safe from potential hazards.

- A work area perimeter should be established around the entire work area, and clearly marked with safety cones.
- The perimeter should be at least 10 ft (3 m) from any hazard within the work area.
- Workers and bystanders should never approach the processor while in operation without first signalling the operator.
- Always be aware of bystanders, ensure they are in the safe zone and not in the danger or work zone.
- Operator work zone is located at the control panel. Always operate the processor controls from the operator's work zone.
- Only the operator can authorize entry into the danger zone, the operator must ensure it is safe to enter the danger zone.
- Always be aware of fellow workers while when winching logs, always make eye contact and have a hand signal scheme worked out.
- Stacked logs could roll off the stack in unpredictable ways, workers should use extreme caution working around the material stack
- Be aware of split wood stacks, split wood can tumble off the top of the pile.

6. Do not winch across a slope and do not operate on hillsides or when working area is cluttered, wet, muddy or icy to prevent slipping and tripping.
7. Do not touch or grasp the rope during winching operation.
8. Always use a winching strap (included) or choker chain or to attach to the log for winching. Damage will occur to the winching rope when dragged under the log if a choker or strap is not used.
9. Always be aware of hazards when winching and moving logs, inspect your work zone to take these hazards into account:
 - objects along winch route
 - structures close or in the work zone
 - winching on a slope

2.16 Winching Safety

1. Check rope condition before using winch. Rope may break during operation if it is knotted, has broken strands or sharp kinks. Replace rope if damaged.
2. Do not exceed winching angle of more than $\pm 25^\circ$, and operate only on level ground.
3. Do not winch down a slope, always winch up a slope, winching down a slope could result in crushing injuries resulting from a log rolling down hill.
4. Do not allow anyone not directly involved with winching within 3 m (10 ft) of winch or logs during winching operation. Keep children away. Logs could roll in unpredictable ways.
5. Always wind the rope under load. Rope will not wind properly if not under load.

2.17 Sign-Off Form

Wallenstein follows the general Safety Standards specified by the American Society of Agricultural and Biological Engineers (ASABE). Anyone who will be using and/or maintaining the Wood Processor must read and clearly understand ALL Safety, Usage and Maintenance information presented in this manual.

Do not use or allow anyone else to use this Wood Processor until such information has been reviewed. Annually review this information before the season start-up.

Make these periodic reviews of SAFETY and OPERATION a standard practice for all of your equipment. We feel that an untrained operator is unqualified to use this machine.

A sign-off sheet is provided for your record keeping to show that all personnel who will be working with the equipment have read and understand the information in the Operator's Manual and have been instructed in the operation of the equipment.

Sign-off Form		
Date	Owner	Employee

Safety

2.18 Safety Signs

2.18.1 Safety Sign Locations

The types of safety signs and locations on the equipment are shown in the illustrations that follow. Good safety requires that you familiarize yourself with the various safety signs, the type of warning and the area, or particular function related to that area, that requires your SAFETY AWARENESS.

Think SAFETY! Work SAFELY!

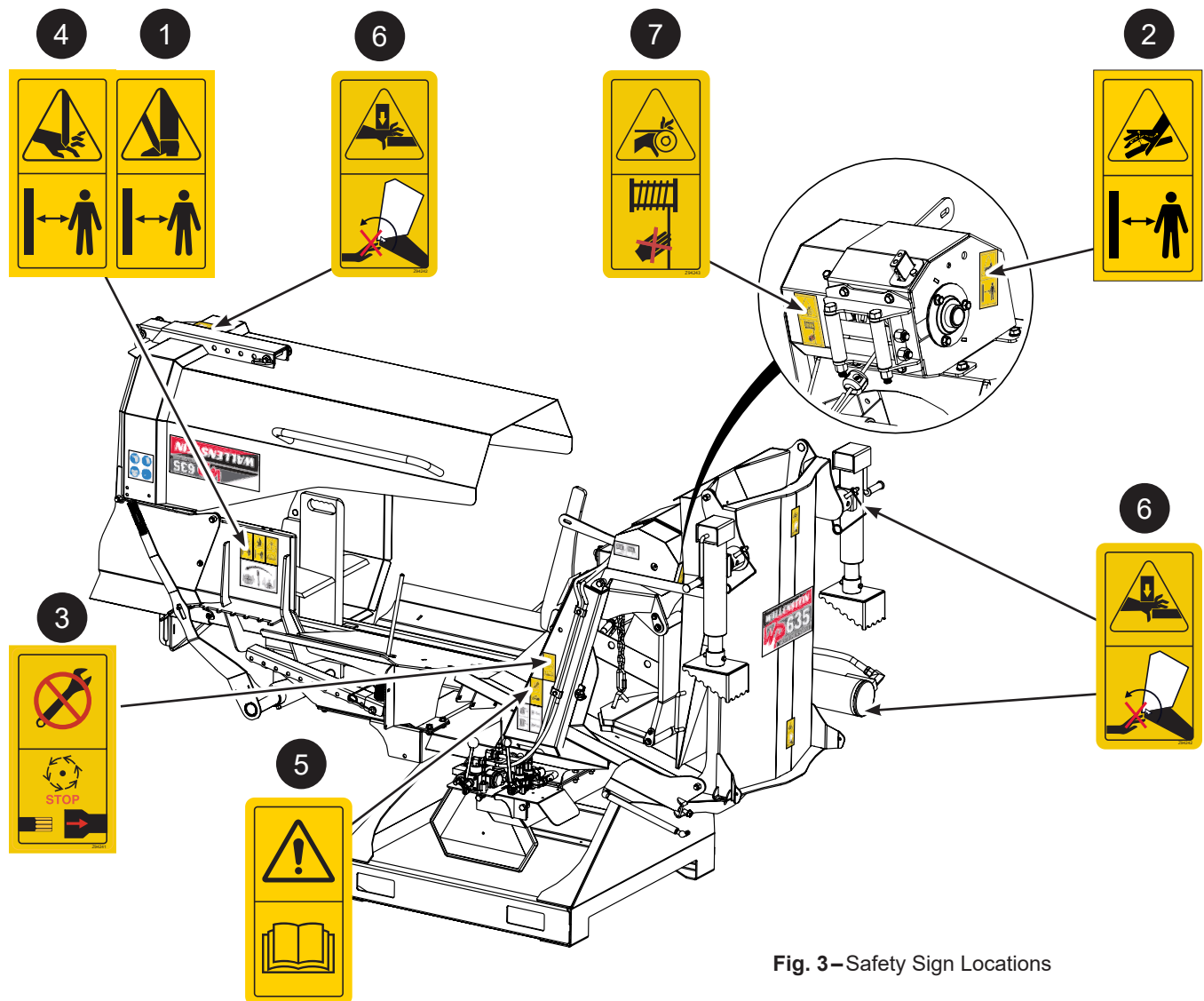

Fig. 3 – Safety Sign Locations

IMPORTANT! If safety signs have been damaged, removed, become illegible or parts replaced without safety signs, new signs must be applied.

New safety signs are available from your authorized dealer.

2.19 Safety Sign Explanations



Caution:

1. Keep feet away from falling log splits,. Always wear steel toed foot wear while machine is operating to avoid serious personal injury.



Caution:

2. Hydraulic fluid under pressure. Do not check for leaks with your hand or fingers when the system is pressurized. Serious injury could result.



Caution:

3. When performing any maintenance on the machine ensure you stop and disengage the PTO. Potential for serious injury or death if the PTO is not stopped and disengaged.



Caution: Pinch point / crushing danger!

4. Keep your hands away from all moving parts during and after split operation! Never try to clear a jammed log with your hands! Wait for all moving parts to come to a complete stop before loading or clearing obstructions.



Caution:

5. Read and understand ALL safety and operating instructions in the manual, read and understand ALL safety labels located on the machine. The most important safety device on this equipment is an informed SAFE operator.



Caution: Pinch point hazard.

6. When lowering or raising the chute into position, be aware of pinch points and keep clear of them to avoid injury.



Caution:

7. Winch entanglement hazard. When using the winch, keep hands clear of the winch rope to avoid injury.

2.20 Replace Damaged Safety Signs

1. Keep safety signs clean and legible at all times.
2. Replace safety signs that are missing or have become illegible.
3. Parts that were replaced with a safety label on them must also have the safety sign replaced.
4. Replacement safety signs are available from your authorized Distributor or Dealer Parts Department or the factory.

2.21 How to Install Safety Signs

1. Be sure that the installation area is clean and dry.
2. Be sure temperature is above 50 °F (10 °C).
3. Determine exact position before removing the backing paper.
4. Remove the smallest portion of the split backing paper.
5. Align the sign over the specified area and carefully press the small portion with the exposed sticky backing in place.
6. Slowly peel back the remaining paper and carefully smooth the remaining portion of the sign in place.
7. Small air pockets can be pierced with a pin and smoothed out using the piece of sign backing paper.

3. Familiarization

3.1 To the New Operator

The Wallenstein Wood Processors are designed to connect to and pull logs to the machine, position for cutting with a chainsaw and split the resulting log. The operator should be familiar with the machine prior to starting.

It is the responsibility of the owner or operator to read this manual and to train all other operators before they start working with the machine. Follow all safety instructions exactly. Safety is everyone's business. By following recommended procedures, a safe working environment is provided for the operator, bystanders and the area around the work site. Untrained operators are not qualified to use the machine.

Many features incorporated into this machine are the result of suggestions made by customers like you. Read this manual carefully to learn how to use the winch, chainsaw and wood splitter safely and how to set it to provide maximum operating efficiency. By following the instructions in conjunction with a good maintenance program, your Wood Processor will provide many years of trouble-free service.

3.2 Safe Condition Procedure

- Clear splitting chamber
- Wind in winch cable
- Shut off hydraulics
- Ensure all components have stopped moving
- Shut off the engine
- Remove and pocket the ignition key
- Ensure the wheels are chocked to prevent movement

IMPORTANT! Make sure all operators understand how to put the machine in Safe Condition before working with this machine.

3.3 Operator Orientation

IMPORTANT! When describing controls, the directions for left-hand, right-hand, backward and forward as mentioned throughout this manual, are determined when standing at the control panel.

3.4 Training

Each operator must be trained in the proper set-up and operating procedures prior to being allowed to operate the machine.

1. Review control location, function and movement directions.
2. Move the unit to a large open area to allow the operator to become familiar with control function and machine response.
3. When a new operator is familiar and comfortable with the machine, they can proceed with the work. Do not allow untrained operators to use the machine. They can endanger themselves and others or damage property and the machine.

3.5 Job Site Familiarization

It is the responsibility of the operator to be thoroughly familiar with the work site prior to starting. Prevent the chance or possibility of problems or accidents by not being in the situation to start with. Some items the operators should check include but are not limited to:

1. Close or cramped work space. Be sure there is sufficient space and clearance for the machine to winch-in the log during operation.
2. Organize the working area to minimize the winching and wood removal distances. The shorter the distances, the faster the work will be finished.
3. Use care when pulling logs from a pile for splitting as they can roll when attaching the rope or winching toward the splitter.
4. Position the machine so prevailing winds blow engine exhaust fumes away from operator's station.

3.6 Equipment Condition

1. Check the general condition of the Wood Processor. Ensure that all nuts and bolts are secure and that a moveable parts are secured and in their proper place.
2. Always inspect the rope as it is pulled out of the winch. Do not use the machine if the rope is cut, frayed, worn or knotted. Any problem can result in early failure and create an unsafe operating condition. Replace damaged rope before resuming work.
3. Inspect hydraulic hoses and connections, ensure they are not damaged and or leaking.

3.7 Machine Components

The Wallenstein Wood Processor consists of a winch mounted in a frame to winch logs into the log lead in chute and then position the log on the log loader chute, up to the log length guide. The hydraulic winch control lever engages the winch motor to wind or unwind the rope. The winch control lever is spring-loaded and will return to its NEUTRAL position when the lever is released. The winch gear lever on the winch engages and disengages the gear on the winch drum. Disengaging the drum allows it to "freewheel" so the rope is easily pulled out.

The operator uses the saw guide to safely align the chain saw to cut the log to the desired length. When the log is cut, it rolls onto the splitting cradle.

Engaging the hydraulic splitter levers causes the hydraulic cylinder to push the log through the 4-way wedge.

The frame is designed to mount to a tractor 3-Point Hitch. Power to the machine can be provided by the tractor hydraulic system or the optional PTO-powered hydraulic Power Pack.

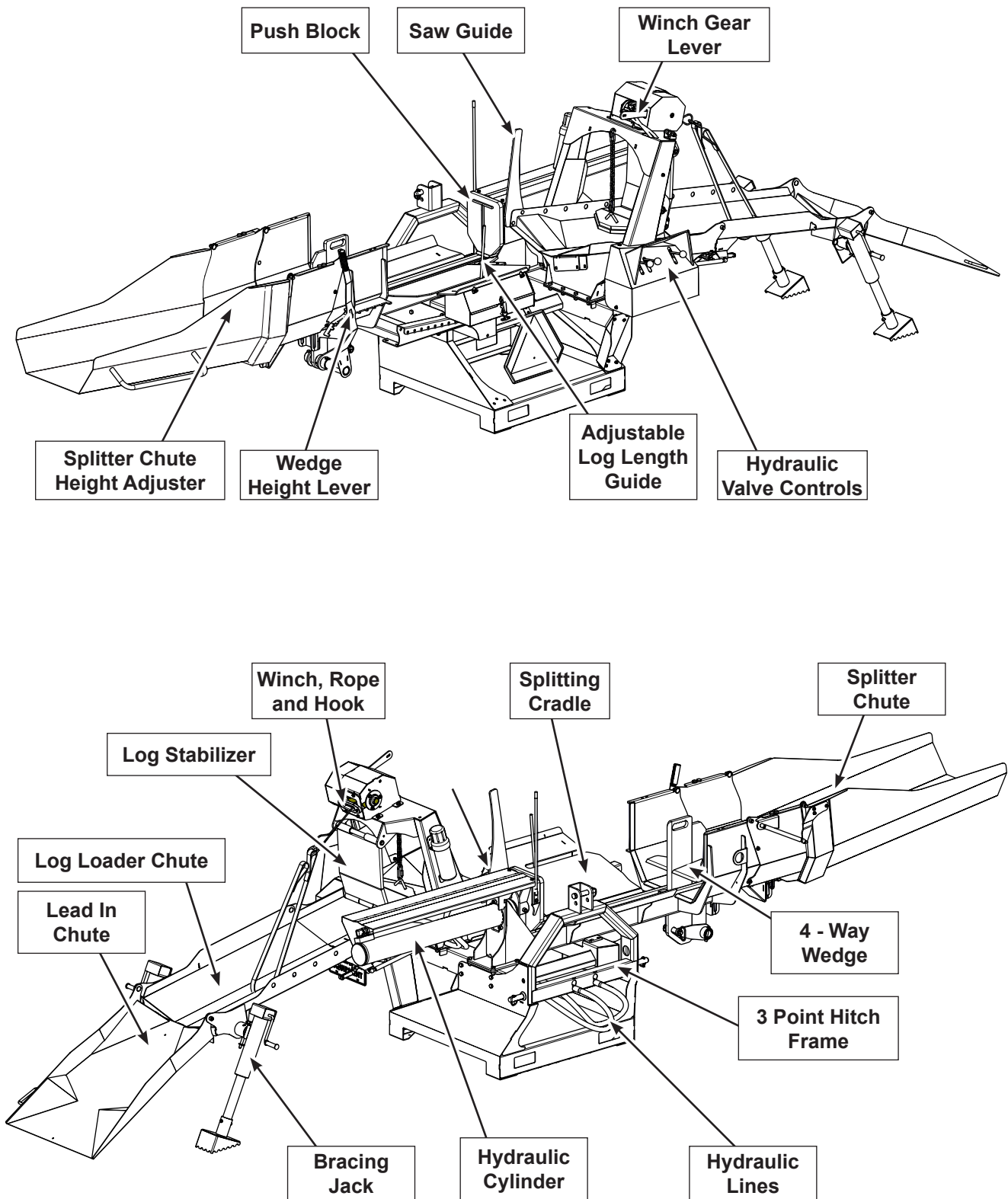

Fig. 4 – Wood Processor Components

3.8 Machine Break-In

Although there are no operational restrictions on the Wood Processor when used for the first time, it is recommended that the following mechanical items be checked:

After 1–5 hours of operation:

1. Check all nuts, bolts and other fasteners. Tighten to their specified torque.
2. Check hydraulic system for leaks. Tighten all leaking fittings and replace any leaking components.
3. Check machine hydraulic oil reservoir. Top up as required.
4. Check condition of winch.
5. Check the condition of the rope. Replace if cut, knotted, worn or if it has any broken strands.
6. Check for entangled material. Remove all entangled material before resuming work.
7. Lubricate all grease fittings.

After 10 hours of operation:

8. Repeat steps 1 through 7 listed above.
9. Go to the normal servicing and maintenance schedule as defined in the Maintenance Section. See page 46.

3.9 Pre-Operation Checklist

Efficient and safe operation of the Wallenstein Wood Processor requires that each operator reads and understands the using procedures and all related safety precautions outlined in this section. A pre-operation checklist is provided for the operator. It is important for both the personal safety and maintaining good mechanical condition that this checklist is followed.

Before operating the Wood Processor and each time thereafter, the following areas should be checked off:

Pre-operation Checklist	✓
Check and lubricate the machine per the schedule outlined in the Maintenance Section.	
Check the condition of the choker strap. Replace if torn or worn out.	
Check for entangled material. Remove any twine, wire or other material that has become entangled.	
Check the condition of the winch rope. Replace cut, knotted, worn or if it has any broken strands. Replace rope if damaged.	
Check the wedge and block. Inspect for damaged or broken components and excessive wear. Lubricate, repair or replace as required.	
Check and ensure that all covers, guards and shields are in place, secured and functioning as designed.	
Check all fasteners and tighten, and ensure your equipment is working and in good repair.	
Check for hydraulic leaks. Tighten fittings or replace components to stop leaks.	
Check engine and machine fluid levels. Top up as required.	
Check the condition of the winch. It must be in good condition to operate properly.	
Check that personal protection equipment including hard hat, safety glasses, safety shoes, safety vest, hearing protection and gloves are being used and in good repair.	
Check that all loose fitting clothing or jewelry is not worn and loose long hair is tied back.	

4. Controls

Before starting to work, all operators should familiarize themselves with the location and function of controls.

4.1 Hydraulic Controls and Auto Cycle

These two hydraulic levers **control the extending and retracting movement of the splitting cylinder**. These two levers control the flow of oil to the cylinder. They are equipped with a detent in the engaged position to allow the cylinder to move through its complete cycle and then return to its starting position automatically.

Lever 1

Controls the first half of the Auto Cycle.

- Push the lever down into the detent to extend the cylinder.
- When the cylinder is extended, the lever kicks out of the detent to neutral.

Lever 2

Controls the second half of the Auto Cycle.

- Push down into detent and the cylinder retracts automatically.
- When the cylinder is fully retracted, the lever kicks out of the detent to neutral.

Auto Cycle



Push both levers down into the detent positions to initiate the splitting Auto Cycle.

- The cylinder extends to split the log. When it reaches full extension, Lever 1 kicks out of the detent to neutral. The cylinder then begins to retract.
- When the cylinder is fully retracted, Lever 2 kicks out of the detent to neutral and the cycle stops.



Lever 1 can be used to manually retract the cylinder:

1. Pull the lever up and the ram will begin to retract.
2. Release the lever and it will return to neutral and the cylinder will stop.

 **NOTE:** *Lever 2 does not have a function in the upper position.*

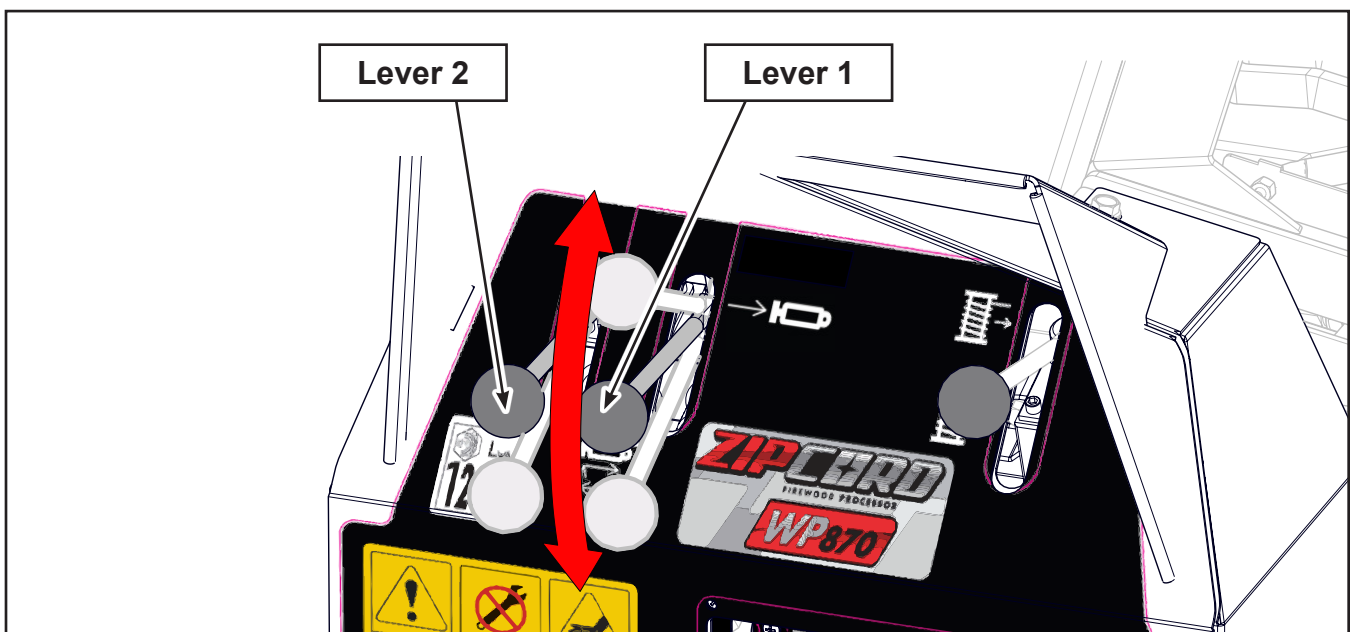
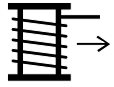

Fig. 5–Hydraulic Controls

4.2 Hydraulic Winch Control

This 3-position spring-loaded-to-center neutral valve controls the flow of oil to the hydraulic motor powering the rope winch.



Pull the lever up to allow the rope to unwind under power.

Release the lever and it will return to neutral to stop winding the rope.

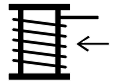

Push the lever down and hold to start the winch and wind the rope.

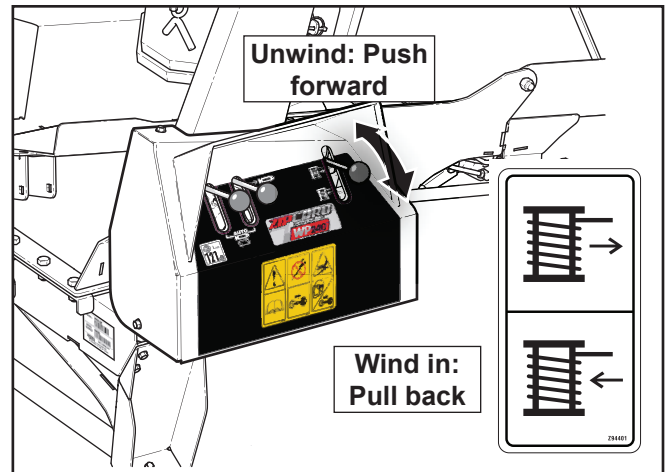
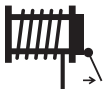

Fig. 6–WP240 / WP270 Winch control

4.3 Winch Gear Lever

This two-position lever controls the gears on the winch drive system.



Pull the lever back to engage the winch gear to the hydraulic motor.



Push the lever forward to disengage the winch gear from the hydraulic motor, allowing the gear to free-wheel. The rope can then be easily pulled out to attach to a log.

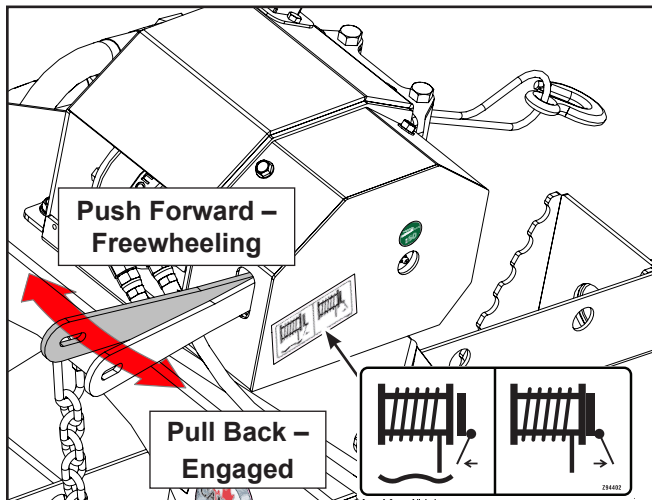

Fig. 7–Winch Gear Lever

! CAUTION!

The Wood Processor winch is designed to use synthetic rope. Use synthetic rope as replacement only. Failure to do so creates an unsafe work environment and voids warranty.



CAUTION!

Winch entanglement hazard. It is recommended that the pull angle of the rope not exceed 25° from the horizontal axis of the machine. Exceeding that angle can subject the machine to a tipping load and tip the machine over.



CAUTION!

Winch entanglement hazard. When using the winch, keep hands clear of the winch rope to avoid injury.

4.4 Splitting Wedge Height Lever

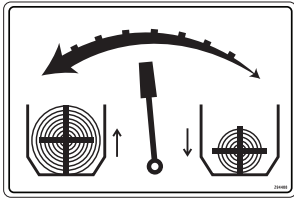

This multi-position lever controls and sets the height position of the horizontal splitting wedge.

At its lowest position the 4-way wedge becomes a two way wedge, to handle smaller logs, increasing the height allows for 4 way splitting of larger logs. Adjust the height as required.

1. Pull the lever out slightly to clear the adjustment cogs, then move the lever towards the engine to lower the splitter wedge.
2. To raise the wedge, pull the lever out slightly to clear the adjustment cogs, then move the lever away from the engine.
3. For even sized splits, align the centre wedge with the centre of the log.

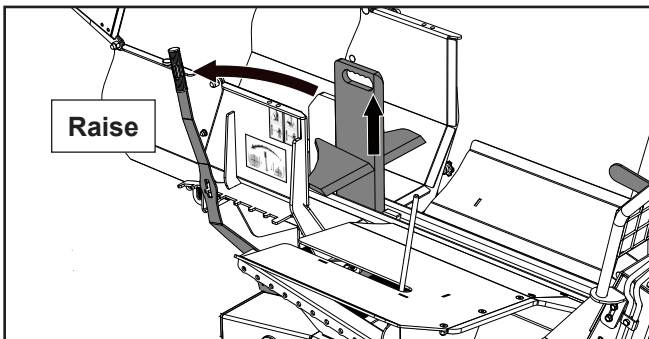
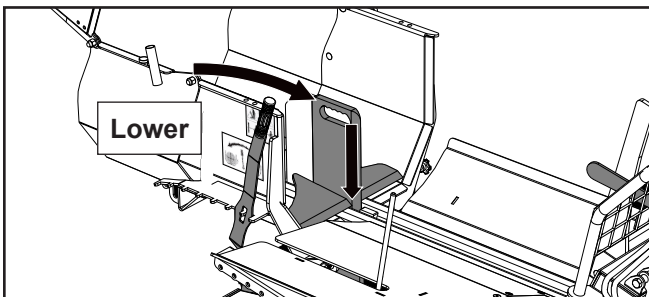

Fig. 8–Splitting wedge height lever and label

4.5 Adjustable Log Length Guide

This adjustable, spring loaded guide is used by the operator to quickly indicate when the log is at the desired length for cutting.

To position the guide to length:

1. Remove the snapper pin from the guide base
2. With a t ape measure, measure from the saw guide to the rod on the log length guide.
3. Move the guide to the desired length and replace the snapper pin.
4. As you advance the log up the chute, the end of the log will contact the spring loaded guide rod, moving it and indicating that the log is at the correct length for cutting.

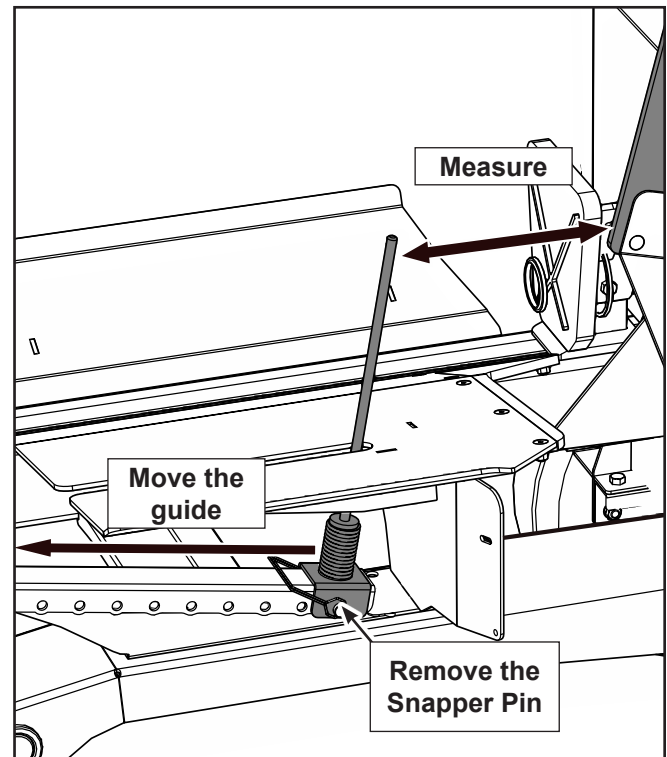

Fig. 9–Log Length Guide

4.6 Splitter Chute Height Adjuster

The adjustable sliding bracket controls the height of the end of the splitter chute, up to 54" (1.37 m). This allows for split wood to be loaded directly onto a conveyor, or into a high sided dumper with out any extra handling.

To adjust the splitter chute height:

1. Lift the splitter chute slightly to take pressure off of the adjuster.
2. Remove the latch pin that secures hitch pin.
3. Pull out the hitch pin that holds the adjuster in place.
4. Raise the splitter chute to the required height, line up the hitch pin holes and replace the hitch pin.
5. Secure the hitch pin with the latch pin.

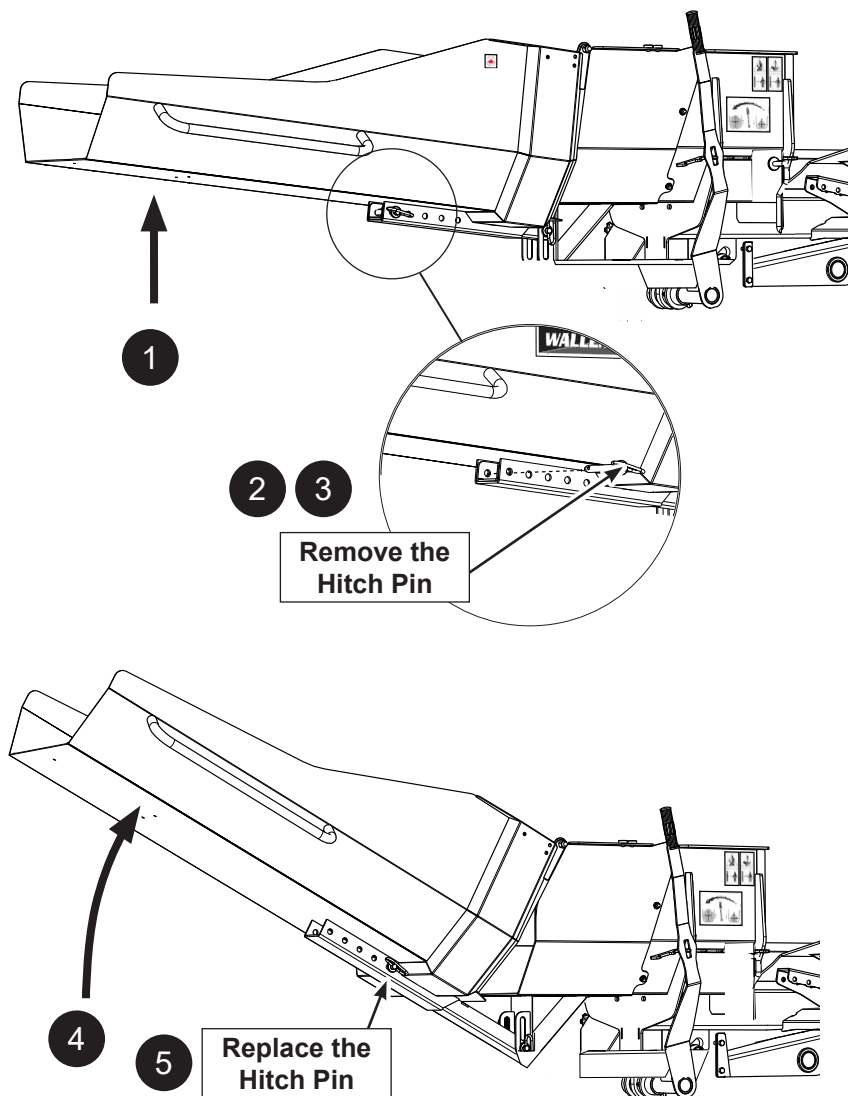

Fig. 10 – Splitter chute position

4.7 Attaching / Unhooking

The Wood Processor should always be located on a level, dry area that is free of debris and other foreign objects. When attaching the machine to a tractor, follow this procedure:

1. Clear the area of bystanders, especially small children.
2. Make sure there is enough room and clearance to safely back up to the machine.
3. Place the tractor arms in their sway position.
4. Back up slowly and align the lower link arms to the mounting brackets on the machine.
5. Be sure the drawbar dimension is at the short length for the tractor being used.
6. Refer to the tractor manual for adjustment procedures. Or the drawbar can be removed.
7. Stop tractor, set park brake, remove ignition key and wait for all moving parts to stop before dismounting.

IMPORTANT! It may be necessary to add weight to the lower lift arms to bring them to the required height.

4.7.1 Mounting

1. Remove the lock pins from the side arms to allow the lower lift arms to be in their fully 'sway' configuration.
2. Align the lower link with the left mounting bracket.
3. Insert the left pin through the ball and install the retainer.
4. Align the right arm to the pin by turning the jackscrew on the arm.
5. Insert the right pin through the ball and install the retainer. Return the jackscrew to its starting position.

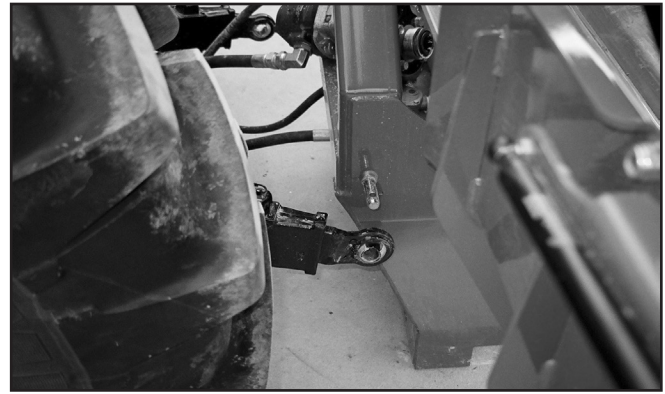

Fig. 11 – Aligning

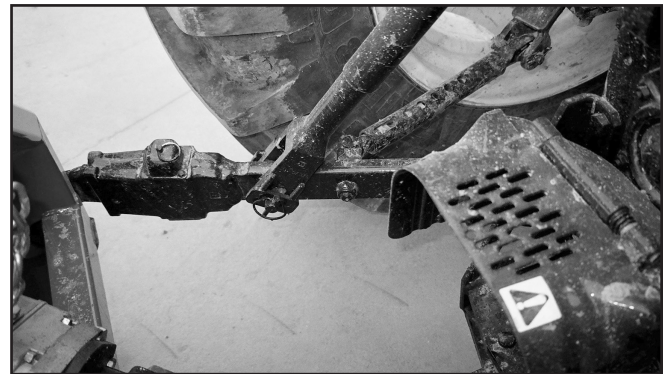

Fig. 12 – Sway anchor pin (typical)

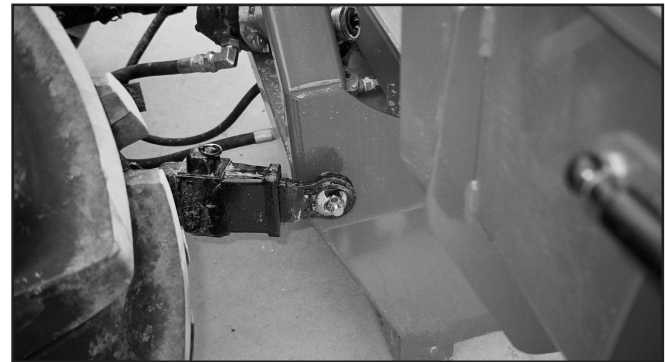

Fig. 13 – Aligned - left

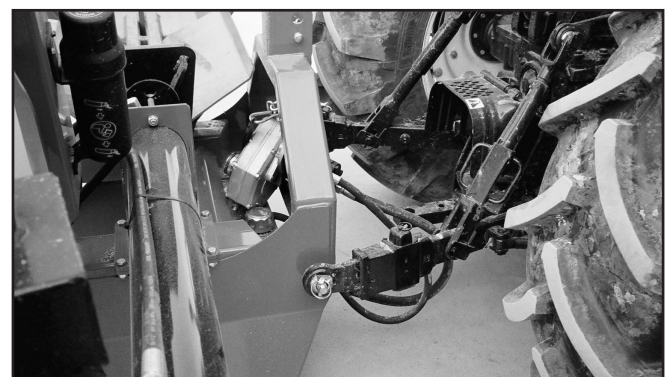

Fig. 14 – Pinned - right

4.7.2 Tractor Hydraulics

Connect the Hydraulic System:

1. Use a clean cloth or paper towel to clean the dirt and build-up from around the couplers and the male tips.
2. Connect the hoses to the tractor couplers. Be sure the couplers are securely seated.
3. Route and secure hoses along the hitch with clips, tape or plastic ties to prevent binding and pinching.
4. Remove the top pin and install the top link. Use the turnbuckle to align the top link. Insert the pins and install the retainers. Return the turnbuckle to its original length and lock.
5. Slowly raise the machine through its working range to make sure the hydraulic components and linkages don't bottom out.
6. Level the machine front and rear, and side to side using the jackscrew on the right arm and the turnbuckle on the top link.
7. To unhook from the tractor, reverse the above procedure. Always park the machine in a dry, level area.



Fig. 15—First hydraulic circuit



Fig. 16—Second hydraulic circuit

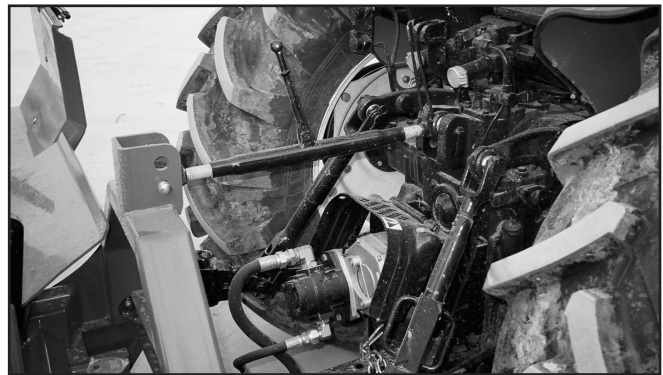

Fig. 17—Top link

WARNING!

Always use caution when working with high pressure hydraulics.



Fig. 18—Leveling adjustments

4.7.3 Power Pack Hydraulics

Ensure the Power Pack is correctly installed and plumbed on the Wood Processor. To install the Power Pack, follow the installation instructions supplied with the unit.

Connect the Hydraulic System

For units with the optional Power Pack, install the gear box on the tractor shaft:

1. Align the splines and slide the gear box on the tractor shaft.

 **NOTE:** Be sure the shaft is clean and free of dirt.

2. Attach the anchor chain to an adjacent frame component to prevent the gear box from turning and hold the assembly on the shaft.
3. Route and secure hoses along the hitch with clips, tape or plastic ties to prevent binding and pinching.
4. Remove the top pin and install the top link. Use the turnbuckle to align the top link. Insert the pins and install the retainers. Return the turnbuckle to its original length and lock.
5. Slowly raise the machine through its working range to make sure the hydraulic components and linkages don't bottom out.
6. Level the machine front and rear, and side to side using the jackscrew on the right arm and the turnbuckle on the top link.
7. To unhook from the tractor, reverse the above procedure. Always park the machine in a dry, level area.

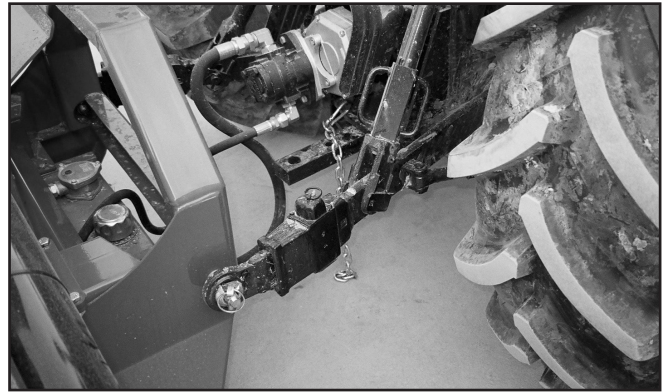

Fig. 19–Gear box

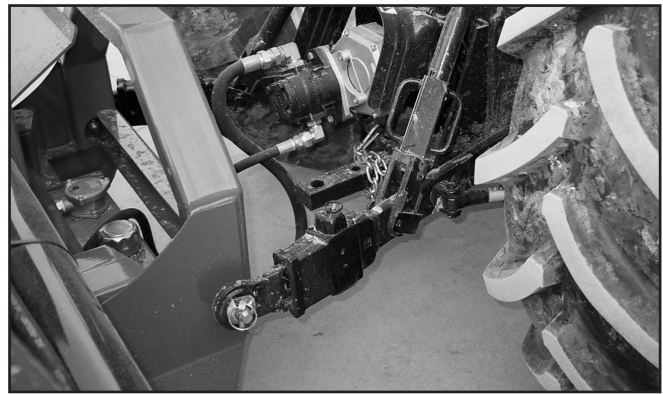

Fig. 20–Anchor chain

WARNING!

Always use caution when working with high pressure hydraulics.



5. Operation



OPERATING SAFETY

- Read and understand owner's manual before starting. Review safety instructions annually.
- Close and secure all guards, deflectors and shields before starting and operating.
- Do not allow anyone within 20 ft (6 m) of machine or logs during operation. Wood chips can be ejected and injure others. Keep children away.
- Move controls to neutral or off position, stop engine, remove ignition key and wait for all moving parts to stop before servicing, repairing or maintaining.
- Do not try to process more than one log at a time. The extra log can be ejected and cause injury.
- Keep your fingers and hands away from cracks in the log that can open or close while splitting.
- Always handle cut logs by holding onto the sides, not the top and bottom.
- Do not load the splitting chamber while the wedge is in motion.
- Do not try to split logs across the grain. Some logs can burst or splinter and fly out of the machine causing injury.
- For unevenly cut logs, always place the wide end down and the most square end against the splitting wedge.
- Never stand directly in line with the winch rope while winching.
- Do not touch winch rope during operation.
- Check rope condition before using winch. Rope may break during operation if it is cut, knotted, has broken strands or worn. Replace rope if damaged.
- Never consume alcoholic beverages or drugs which can hinder alertness or coordination while operating this equipment. Consult your doctor about operating this machine while taking prescription medications.
- Operate only on level ground.
- Do not exceed winching angle of more than 25°.
- Always winch up a slope. Do not winch across a slope.
- Do not operate on hillsides or when working area is cluttered, wet, muddy or icy to prevent slipping and tripping.
- Use care when pulling logs from a pile for splitting as they can roll when attaching rope or winching toward wood processor.
- Position machine so prevailing winds blow engine exhaust fumes away from operator's station.
- Keep working area clean and free of debris to prevent tripping. Operate only on level ground.
- Stop engine when leaving unattended.
- Do not exceed a safe travel speed when transporting.
- Read the chainsaw operator's manual and follow all safety instructions.

The operator has the responsibility of being familiar with and following all operating and safety procedures.

Although the Wood Processor is easy to use, each operator should review this section to get familiar with the detailed safety and operating procedures. When using this machine, follow this procedure:

5.1 Be Prepared

- Review Safety rules on page 8.
- Clear the area of bystanders, especially small children.
- Each operator must be trained and familiar with the set up and operation of the Wood Processor and its components.
- Review the Machine Components (see page 23).

- Review and follow the Pre-Operation Checklist (see page 25).
- Review operation and function of the Controls (see page 26).
- Survey the work site, move to a clear, level work area and position at the work site. Do not start the Wood Processor until it is in position.
- Set up the machine (see page 35).
- **Wear appropriate Personal Protective Equipment whenever operating the Wood Processor or working in the vicinity.**

5.2 Starting

1. Move all controls to neutral or off position.
2. Move the throttle to its 1/4 throttle position.
3. Start tractor engine.
4. Run the engine for a few minutes to allow it to warm.
5. Reduce engine RPM to low idle.
6. Engage PTO or place hydraulic circuit lever in detent.
7. Increase throttle setting to maximum speed for operation.
8. Move to the operator's station to proceed with the work.
9. Start attaching logs to the winch.

5.3 Stopping

1. Stop winching, cutting or splitting logs.
2. Slow engine RPM.
3. Disengage PTO control or move hydraulic lever out of detent into its off position.
4. Stop engine using ignition switch.

5.4 Emergency Stopping

If an emergency occurs:

1. **Shut off the engine.**
2. **Set all hydraulic controls to neutral.**

Correct emergency situation before restarting engine and resuming work.

5.5 Machine Set-Up

Follow this procedure to prepare and set-up the machine at the work site:

CAUTION!

Position the machine so any wind blows the exhaust gases and fumes away from the operator's station.

1. Use the tractor to position the machine at the work site.

2. Remove the snapper pins securing the bracing jacks and turn them up to the bracing position.
3. Replace the snapper pins to secure the jacks.

 **NOTE:** Angle the jacks upward so they will contact the ground evenly when the chute is lowered.

4. Remove the latch pin that holds the chute lock arm to the log loader chute.
5. Pull the lock arm away from the chute and swing it down. Secure it to the side of the frame with the latch pin.

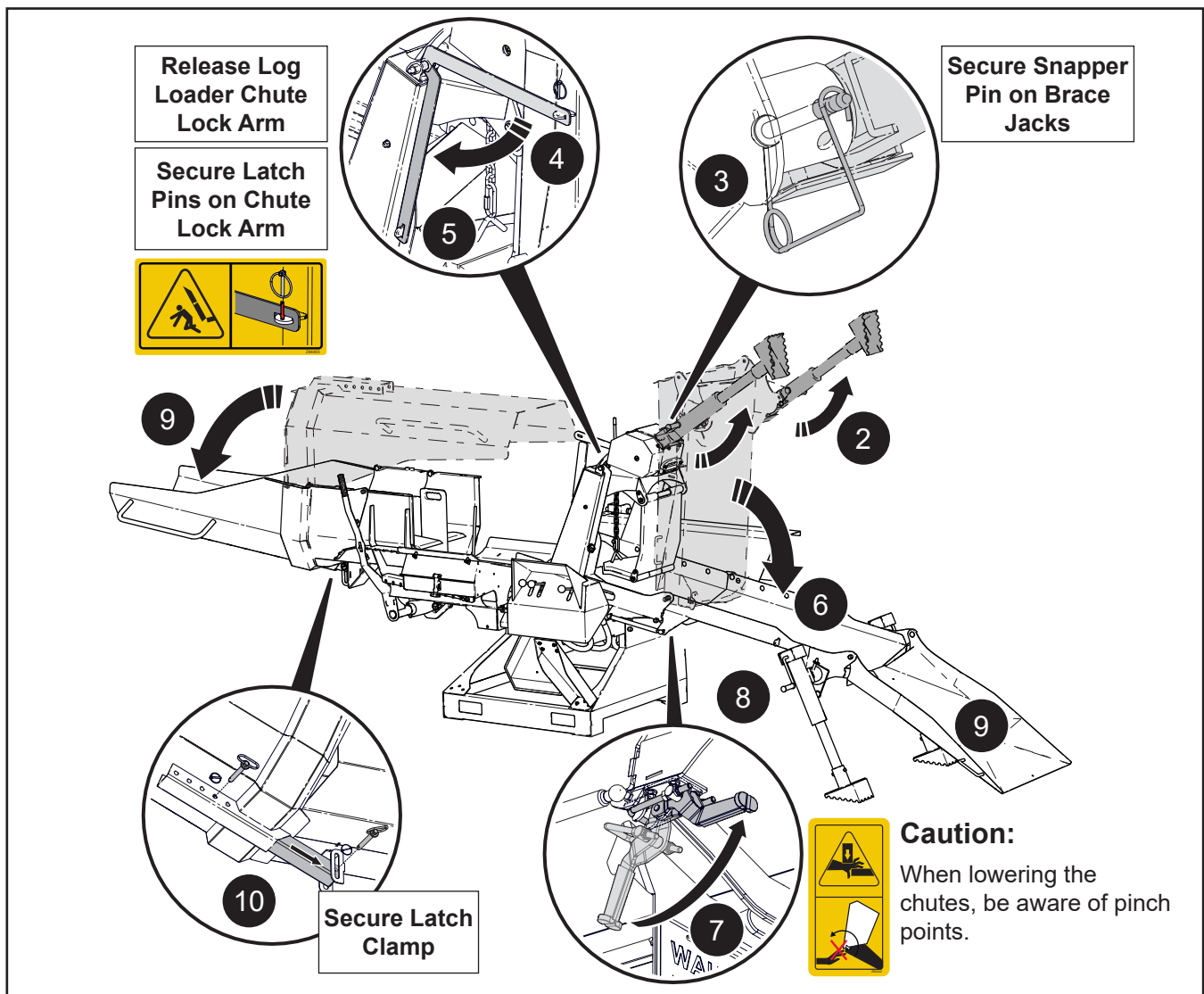

Fig. 21– Machine Set Up

6. Carefully fold the log loader chute down.
7. Under the chute, hook the latch over the latch catch. Snap the handle of the latch clamp into lock position. There is one on each side.
8. Crank the bracing jacks until the jack feet are firmly into the ground.
9. Carefully unfold the splitter chute.
10. Adjust the splitter chute to the required height, using the chute lock arm and placing the hitch pins in the appropriate hole position.
11. Unclip the winch hook from the log stabilizer chain.
12. Check that the log stabilizer chain allows the stabilizer to move freely and not hinder the log.

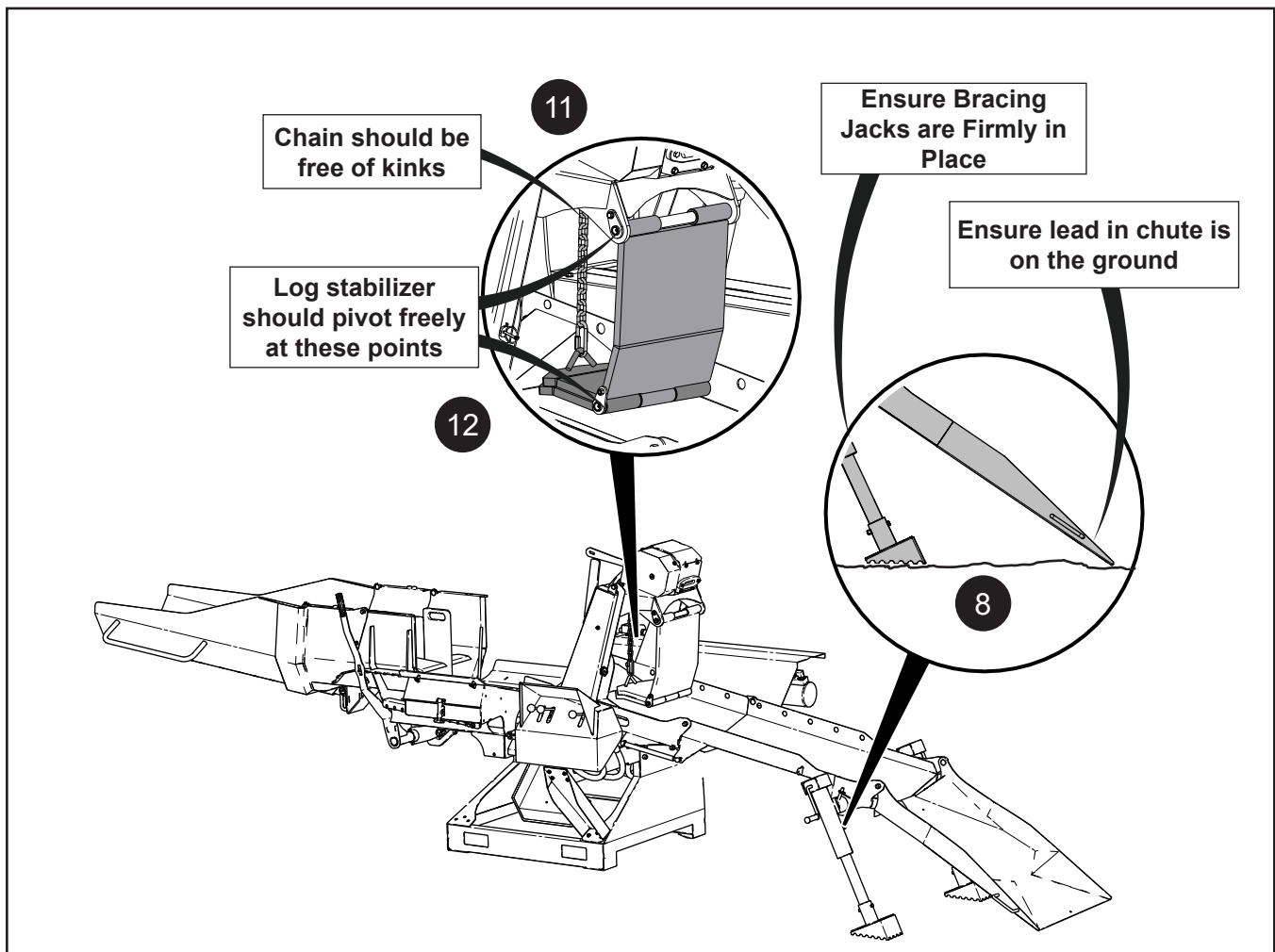

Fig. 22– Machine Set Up

13. Finally, adjust the splitter chute to the required height, crank the bracing jacks so they are firmly on the ground, but ensure the front lip of the lead in chute is on the ground (to avoid catching on logs). If required, adjust the 3 point hitch so the lead in chute is level with the ground and the bracing jacks have a firm grip.
14. Move the wagon, trailer or conveyor into position under the discharge chute if desired or appropriate for your application.
15. Reverse the above procedure when preparing to leave the work site or transporting.

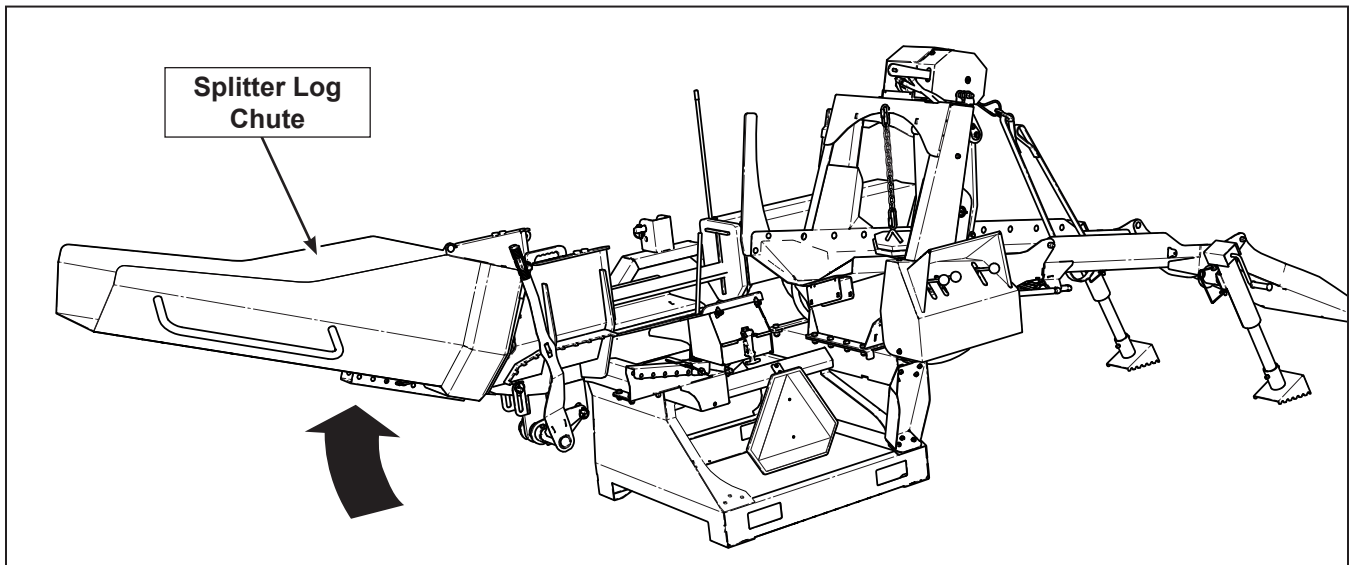

Fig. 23–Splitter log chute

6. Processing Operation

Have the Wood Processor ready to operate and set up at the work site. Ensure the operator is wearing the appropriate safety equipment (see page 33). Have the chainsaw ready.

Attach the 60" (1.5 m) winch strap to the log, then attach the winch rope to the strap. **Do not attach the winch rope directly to the log.** Alternatively, a standard log chain can be used.



Fig. 24–Winch strap

IMPORTANT! Always use the winch strap to attach to the log, not the winch rope. Attaching it in this manner and dragging it along the ground will damage it.



Fig. 25–Attaching choker or strap

6.1 Winching

1. Release the winch rope by moving the winch gear lever to the left.
2. Grasp the hook on the winch rope, and pull the rope out to the logs.
3. Wrap the winch strap around the first log. You may need to roll the log onto the scrap using a log peavey (available from your dealer).
4. Attach the winch hook onto the winch strap.

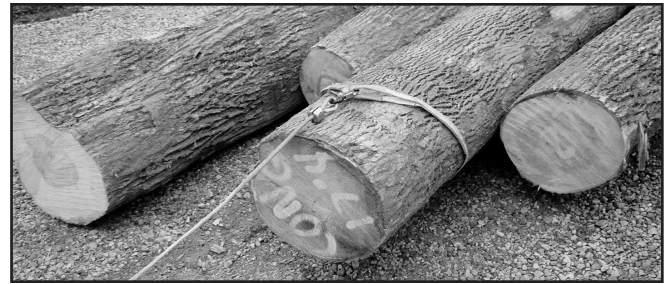

Fig. 26–Winch Strap and Hook

5. Engage winch drive mechanism with the winch gear lever.
6. Use the winch to pull log into log lead in chute. Ensure the log does not catch on the front lip of the lead in chute.
7. Continue to winch the log up log loader chute to the log stabilizer and stop the winch.



Fig. 27–Winching first log

8. Ensure the log is stable, disengage the winch gear, pull out the rope slightly.
9. Detach the winch hook from the strap, and move the strap to the far end of the log.
10. Pull out the winch rope and re-attach the winch hook.



Fig. 28–Re-attach far end

11. Engage the winch gear, and begin winching the log through the log stabilizer up to the log length guide.
12. Cut the log to length, and allow it to roll into the splitting cradle.

13. Check that the 4 way wedge is set to the appropriate height, adjust if necessary.
14. Activate the hydraulic controls to split the log.
15. Winch the log up to the guide, and begin cutting again.

IMPORTANT! The Wood Processor winch is designed to use synthetic rope. Use synthetic rope as replacement only. Using anything else creates an unsafe work environment and voids warranty.

6.2 Position the Log

1. Continue to winch the log up log loader chute to the log stabilizer and stop the winch.

IMPORTANT! Stop winching when the hook reaches the winch. If the operator is winching and the log is not moving, it is most likely because the winch is fully retracted. Continuing could pull the hook off the end of the rope.

2. Ensure the log is stable, disengage the winch gear, pull out the rope slightly.
3. Detach the winch hook from the strap, and move the strap to the far end of the log.



Fig. 29—Move strap to end of log

4. Pull out the winch rope and re-attach the winch hook.
5. Engage the winch gear, and begin winching the log through the log stabilizer up to the log length guide.
6. Cut the log to length, and allow it to roll into the splitting cradle (see Cutting page 39).

6.3 Cutting

WARNING!

Review the chainsaw operator's manual and follow all safety instructions.

Always wear appropriate Personal Protective Equipment (PPE) when using a chainsaw.

1. Make sure the chainsaw is sharpened and in good working order.
2. Ensure the log is up to the log length indicator.
3. Use the saw guide to safely align your cuts.
4. Apply pressure and use the chainsaw to cut the log.
5. Be careful to decrease cutting pressure as you finish the cut, there is a chainsaw bumper below the cutting area to minimize damage to the chain teeth if you accidentally follow through.
6. Let the log roll into the splitting cradle.

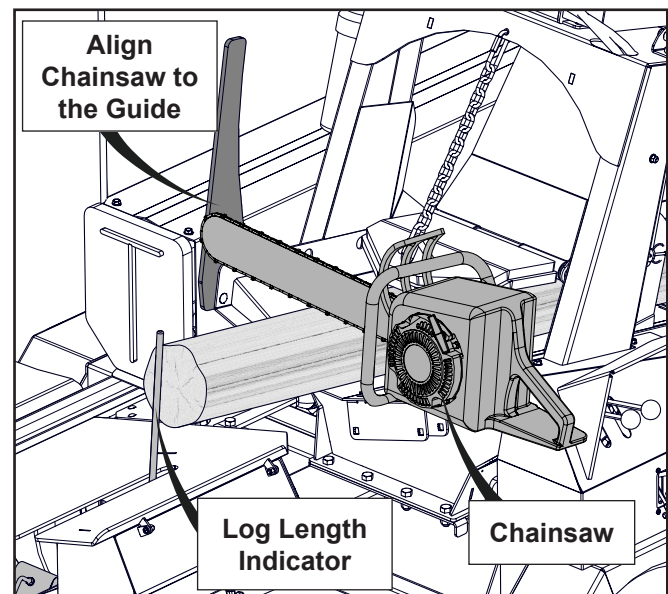



Fig. 30—Cutting the log

 **NOTE:** The optional P201 Pivoting chainsaw Holder makes cutting easier. See Accessories on page 22.

6.4 Splitting

After each cut, the log will roll onto the splitting cradle. When splitting, follow this procedure:

1. Using the wedge height lever, set the height of the wedge according to the diameter of the log.
2. Push both splitting control levers down into detent.

The splitting ram will begin the auto-cycle—it extends to split the wood, then retracts automatically.

The control levers reset to neutral when the auto-cycle completes.

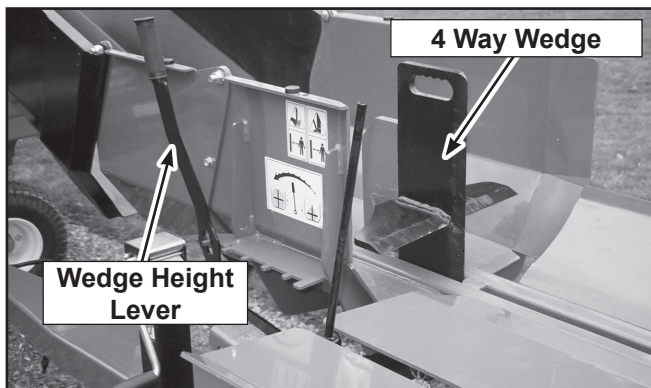

Fig. 31—Splitting cradle

3. Winch the log up to the guide again to make the next cut. Continue cutting and splitting to finish the log.



Fig. 32—End of first log

6.5 Next Log

As the first log finishes, it will be too short to winch in. At this point, winch in another log behind the first one and use it to push the first log into the cutting area.



Fig. 33—Push first log with next

1. Ensure the log in the Wood Processor is stable, then release the rope and hook.
2. Pull the rope out to the second log.
3. Wrap the winch strap around log. You may need to roll the log onto the strap using a log peavey.
4. Attach the winch hook onto the winch strap.
5. Engage winch drive mechanism with the winch gear lever.
6. Use the winch to pull log into log lead in chute. Ensure the log does not catch on the front lip of the lead in chute.
7. Continue to winch the log up to the first log.
8. Use the second log to push the first one up to the cutting guide.
9. After a few cuts, reposition the winch strap to the far end of the second log, and continue winching and cutting.

6.6 Last Log

As you finish the last log, you will find it is too short to winch in. At that point:

1. Move the log using a log peavey as a lever inserted into holes at side of chute.

CAUTION!

Risk of serious injury. Never attempt to push a log through the stabilizer opening by hand. The stabilizer could drop suddenly and cause serious injury. Always use appropriate procedure and tools to push or pull the log through the opening.



Fig. 34—Use peavey to push last log up

2. Lever the log up to the cutting guide, until it is fully processed.
3. Be aware of the heavy log stabilizer. Use caution when finishing the last log.

6.7 Efficient Processing

We recommend following this procedure for an effective work flow:

1. Move log into position with winch or peavey.
2. Cut log and let it roll into the splitting cradle.
3. Engage splitter.
4. While the log is being automatically split, use the winch to move the next log segment into position.
5. Cut the next log segment.
6. The previous log has finished splitting and the ram has returned to its start position.
7. Allow the cut log to roll into the cradle, begin splitting, while winching the log into position for the next cutting.
8. Repeat until complete.

6.8 Pull Angle

CAUTION!

Risk of machine tip over. Do not exceed $\pm 25^\circ$ pull angle from the horizontal axis of the machine.

When winching a log, do not exceed $\pm 25^\circ$ from the horizontal axis of the machine. Exceeding that angle risks tipping the machine over.

Use a log peavey to move the log in line with the Wood Processor.

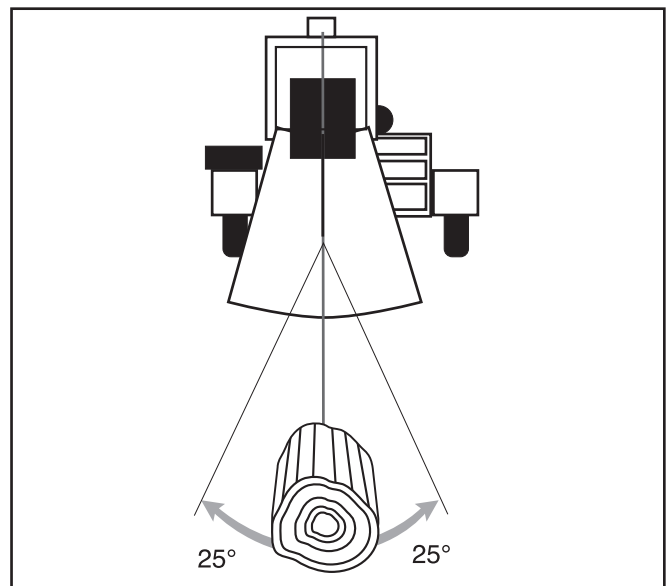

Fig. 35—Pull angle must be less than 25°

6.9 Wood Discharge

The split wood is pushed out of the chute as each additional log moves through the machine.

Set the chute height to pile on the ground or into a trailer, wagon or conveyor.



Fig. 36—Ground pile

7. Transporting



TRANSPORT SAFETY

- Comply with state and local laws governing safety and transporting of machinery on public roads.
- Check that all the lights, reflectors and other lighting requirements are installed and in good working condition.
- Do not exceed a safe travel speed. Slow down for rough terrain and cornering.
- Be sure the Wood Processor is hitched positively to the tow unit with retainers installed through the mounting pins.
- Do not drink and drive.
- Be a safe and courteous driver. Always yield to oncoming traffic in all situations, including narrow bridges, intersections, etc. Watch for traffic when operating near or crossing roadways.
- Never allow riders on the machine.

When transporting the machine, review and follow these instructions:

1. Clear the area of bystanders, especially small children.
2. Check that all the lights and reflectors required by the highway authorities are in place, clean and working.
3. Make sure that the machine is securely attached to the tow unit with a retainer through the 3 point hitch arms.
4. Do not allow riders.
5. Never exceed a safe travel speed. Slow down when encountering rough road conditions and cornering.
6. Do not drink and drive.
7. Reconnect the lead in chute lock arm and latch pin, check that all components of the Wood Processor are secure for travel.



Fig. 40—Moving



Fig. 41—Lead in chute lock arm

8. Storage



STORAGE SAFETY

- Store the unit in an area away from human activity.
- Do not permit children to play on or around the stored machine.
- Store the unit in a dry, level area. Support the frame with planks if required.
- Drain the fuel if storing for longer than 1 month

8.1 Placing Wood Processor in Storage

After the season's use or when the machine will not be used for a period of time, completely inspect all major systems of the Wood Processor. Replace or repair any worn or damaged components to prevent any unnecessary down time at the beginning of the next season.

Follow this procedure before storing:

1. Remove all material from the machine.
2. Thoroughly wash the machine with a pressure washer or water hose to remove all dirt, mud or debris.
3. Inspect all moving parts for entangled material. Remove all entangled material.
4. Check the condition of winch rope. Replace or adjust as required.
5. It is best to store the machine inside. If that is not possible, cover with a waterproof tarpaulin and tie down securely.

8.2 Removing From Storage

When removing this machine from storage, follow this procedure:

1. Remove the tarpaulin if covered.
2. Review and follow the pre-operation checklist.



Fig. 42 – Stored position

9. Service and Maintenance



MAINTENANCE SAFETY

- Good maintenance is your responsibility. Poor maintenance is an invitation to trouble.
- Follow good shop practices.
 - Keep service area clean and dry.
 - Be sure electrical outlets and tools are properly grounded.
 - Use adequate light for the job at hand.
- Make sure there is plenty of ventilation. Never operate the engine of the engine in a closed building. The exhaust fumes may cause asphyxiation.
- Before working on this machine, shut off the engine, set the brake, and turn fuel valve off.
- Never work under equipment unless it is blocked securely.
- Always use personal protection devices such as eye, hand and hearing protectors, when performing any service or maintenance work. Use heavy gloves when handling sharp components.
- Where replacement parts are necessary for periodic maintenance and servicing, genuine factory replacement parts must be used to restore your equipment to original specifications. The manufacturer will not be responsible for injuries or damages caused by use of unapproved parts and/or accessories.
- A fire extinguisher and first aid kit should be kept readily accessible while performing maintenance on this equipment.
- Periodically tighten all bolts, nuts and screws and check that all electrical and fuel connections are properly secured to ensure unit is in a safe condition.
- When completing a maintenance or service function, make sure all safety shields and devices are installed before placing unit in service.

9.1 Fluids and Lubricants

1. Grease

Use an SAE multipurpose high temperature grease with extreme pressure (EP) performance. Also acceptable is an SAE multipurpose lithium base grease.

2. Storing Lubricants

Your machine can operate at top efficiency only if clean lubricants are used. Use clean containers to handle all lubricants. Store them in an area protected from dust, moisture and other contaminants.

3. Hydraulic Oil

Power Pack users: Use Dexron III oil for all operating conditions.

Tractor users: consult your tractor operation manual.

9.2 Greasing

1. Use a hand-held grease gun for all greasing.
2. Wipe grease fitting with a clean cloth before greasing, to avoid injecting dirt and grit.
3. Replace and repair broken grease fittings immediately.
4. If fittings will not take grease, remove and clean thoroughly. Also clean lubricant passageway. Replace fittings if necessary.

Location	Grease Points – Every 50 hours or annually
1	Winch
2	Upper Right-hand Log Stabilizer
3	Upper Left-hand Log Stabilizer
4	Lower Right-hand Log Stabilizer
5	Lower Left-hand Log Stabilizer
6	Wedge Adjustment Arm bushing

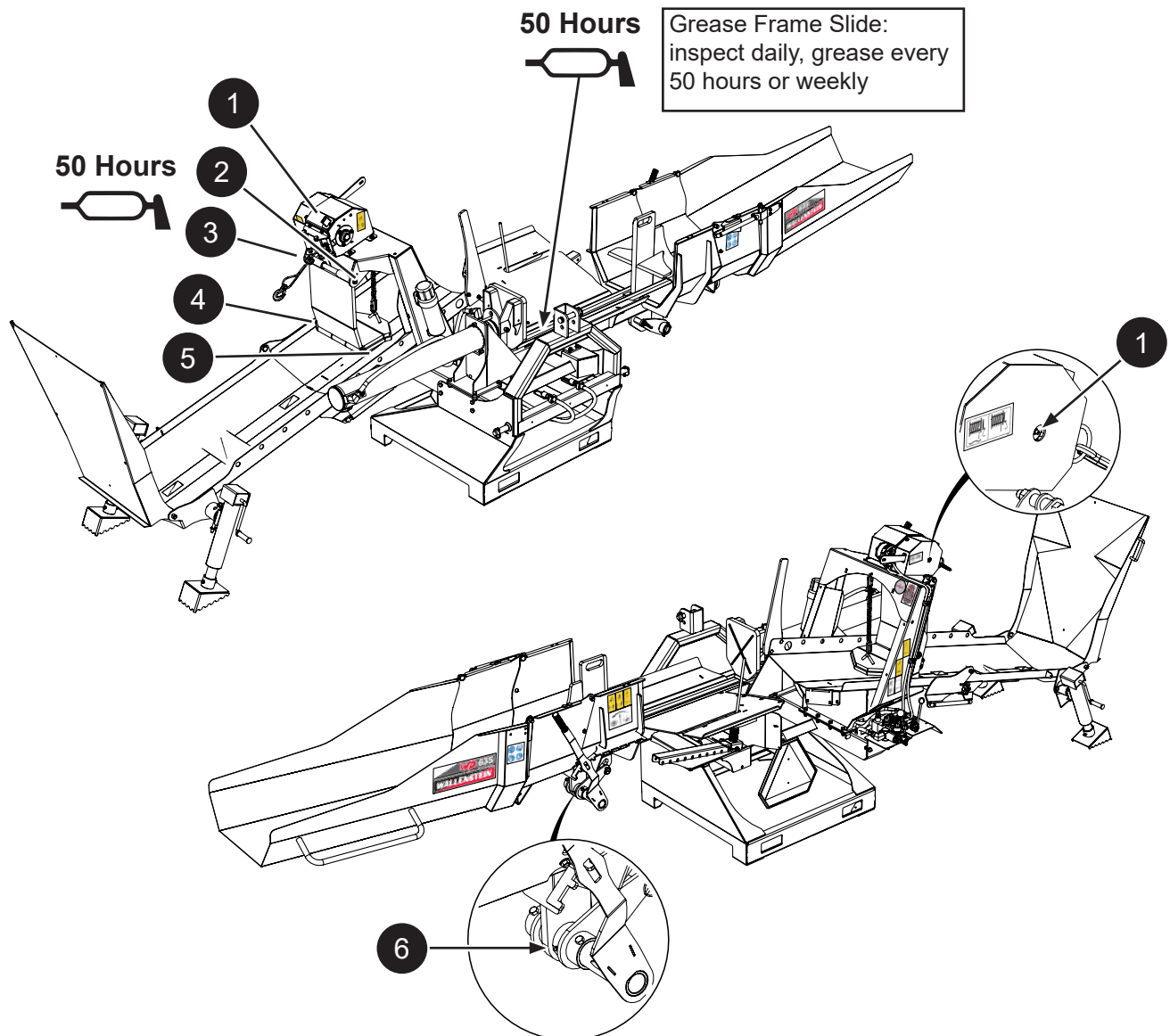

Fig. 43–Grease points

9.3 Service Illustration

This illustration shows the general location of service points for all models in this manual.

On a regular basis, check the condition of all hydraulic lines, hoses and fittings. Replace any that are damaged. Re-route those that are rubbing, pinched or crimped. Tighten any fitting that is leaking. Ensure fittings are clean and free of dirt.

Every 100 hours or annually: Wash and clean the Wood Processor, remove entangled material, wood chips, small debris

Winch Rope: Inspect during each use.

Grease Frame Slide: Inspect daily, grease every 40 hours or weekly.

On a regular basis, check all nuts, bolts and screws. Make sure they are all properly torqued.

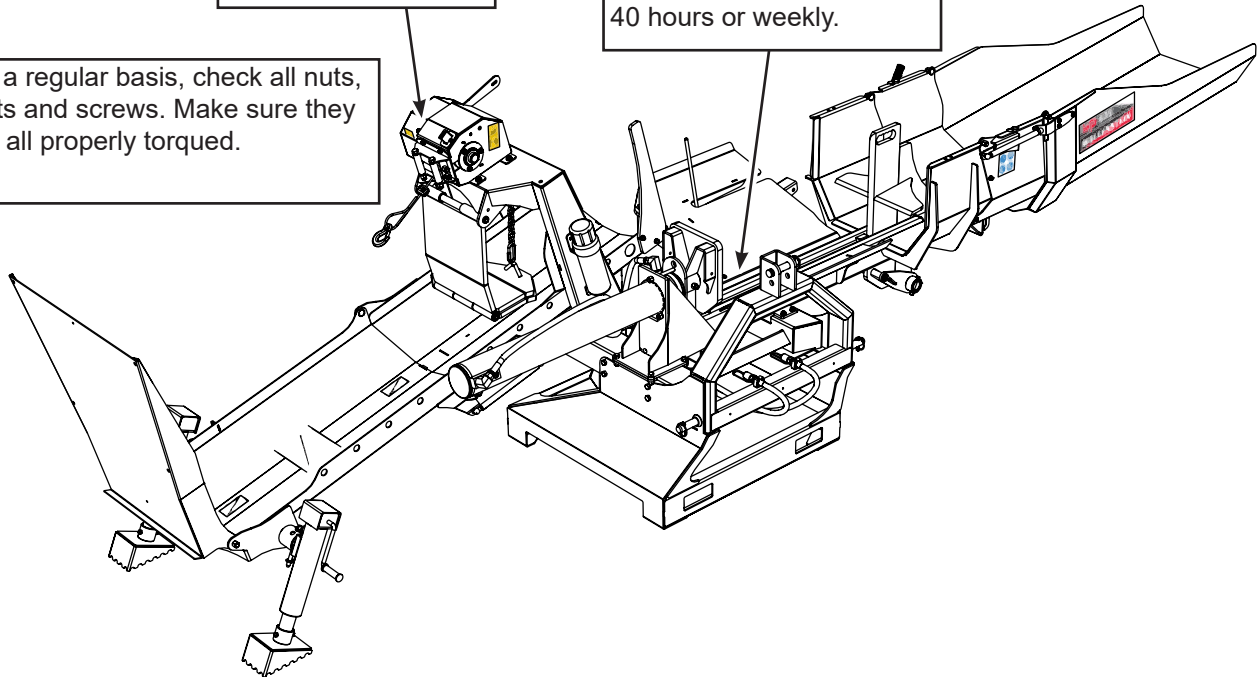

On a regular basis, check all jacks, hinge and swivel points, clean and lubricate as required

Hydraulic Oil: See your tractor's maintenance instructions.
Optional Power Pack: check every 40 hours.

Hydraulic Filter: Tractors: see your tractor's maintenance instructions.
Optional Power Pack: clean every 100 hours or annually

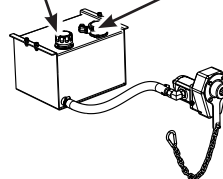

9.4 Maintenance Schedule

Refer to your engine instruction manual for specific maintenance instructions / requirements.

Maintenance schedule

Perform at time shown or hour interval, whichever comes first. Item	Every 8 hours or Daily	Every 40 hours or Weekly	Every 100 hours or Annually
Check hydraulic hoses, fittings, frame slide	✓		
Check that all fasteners are secure	✓		
Check hydraulic oil level		✓	
Grease frame slide, hinges, pivot points			✓
Change hydraulic oil filter			✓
Clean machine			✓

9.5 Hydraulic System Oil and Filter Change (Optional Power Pack only)

NOTE: This procedure is for the Wood Processor's Optional Power Pack. Please refer to your tractor's maintenance guide concerning hydraulic oil and filter service instructions.

NOTE: The tank does not have to be drained to clean the filter.

By following a careful service and maintenance program, expect many years or trouble-free operation.

9.5.1 Drain and replace oil

1. Move controls to neutral or off position, stop engine, remove ignition key and wait for all moving parts to stop before servicing, repairing or maintaining.
2. Allow the machine to cool before changing the oil. Hot oil can cause burns if it contacts exposed skin. It is best to change oil while the machine is warm to keep the contaminants in suspension.
3. Place a pan under the hydraulic oil reservoir drain.
4. Remove the drain plug and drain the oil.
5. Replace the drain plug.
6. Fill the reservoir with 7.1 US gal (27 L) of Dexron III oil.
7. Operate the machine for 1–2 minutes while operating cylinder. Check oil level. Check for leaks at the drain.
8. Oil level should be approximately 1" (25 mm) from the top of the tank
9. Dispose of the old or any spilled oil in an approved manner.

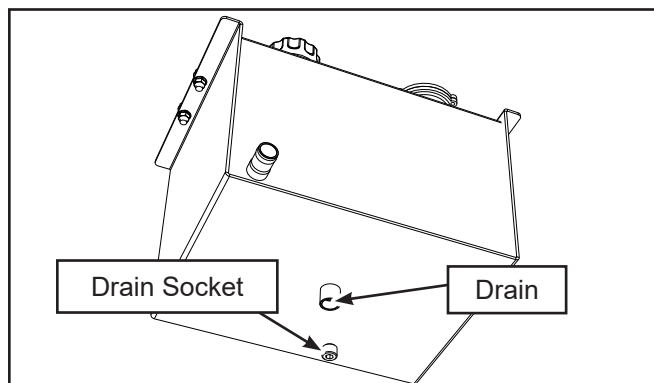

Fig. 44—Bottom view of oil reservoir

9.5.2 Remove and clean the filter

1. Remove the 3 screws from the oil filter cover on the top of the reservoir.
2. Remove the filter cover and pull out the hydraulic oil filter.
3. Wash the filter screen with mineral spirits (Var-sol™). Inspect the filter mesh for any holes, perforation, rust or tears.
4. Place the filter screen into the tank and secure the filter cover.

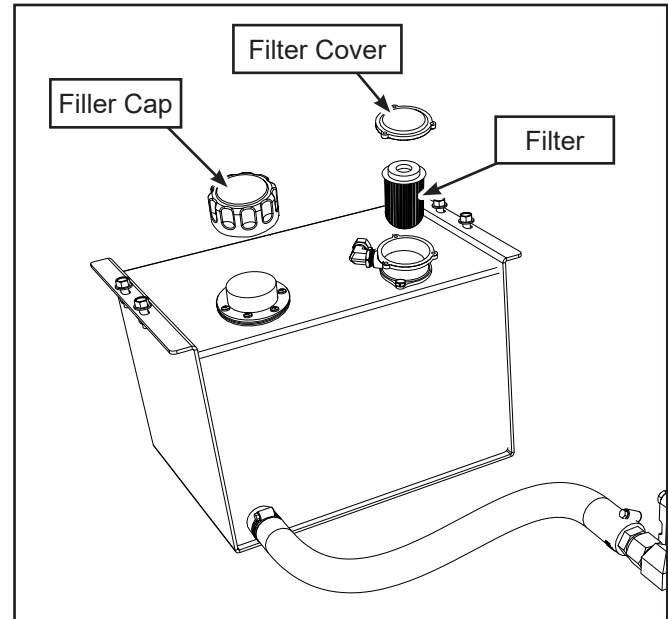

Fig. 45—Reservoir filler cap and filter

10. Trouble Shooting

The Wallenstein Trailer Wood Processor uses hydraulic power to move a hydraulic cylinder rod to split wood or logs. It is a simple and reliable system that requires minimal maintenance.

In the following table, we have listed many of the problems, causes and solutions to the problems that you may encounter.

If you encounter a problem that is difficult to solve, even after having read through this trouble shooting section, please call your local dealer, distributor or Wallenstein. Before you call, please have the serial number for your Wood Processor handy.

Problem	Cause	Solution	Caution ⚠
Winch motor does not move	Rope jammed	Disengage winch gears, pull rope out and guide rope on to the spool when retracting	
Rope does not pull out	Winch gears engaged	Disengage winch gears	
Rope does not retract	Winch gears disengaged	Engage winch gears	
Cylinder rod moves slowly or does not move.	Wood jammed around wedge.	Shut machine off and safely remove wood.	Make sure machine is off
Cylinder rod / Winch motor moves slowly or does not move.	No pressurized hydraulic oil.	Oil filter plugged. Change filter.	Make sure machine is off and cooled down.
	No pressurized hydraulic oil	Low hydraulic oil level, top up	Make sure machine is off and cooled down
	Not enough pressure.	Call technician, system relief setting may be low.	Make sure machine is off and call hydraulic technician.
	Low engine speed.	Check that choke is off, check throttle is set to maximum.	
Control handle doesn't go to neutral after rod is fully retracted.	Detent set too tight.	Call technician, adjustment required with detent on valve.	Make sure machine is off and call hydraulic technician.
	Hydraulic fluid too cold.	Allow machine to warm up.	
	Hydraulic fluid is too old or contaminated.	Change hydraulic fluid and filter	Make sure machine is off and cooled down.
Control handle goes to neutral before rod is fully retracted.	Detent set too loose.	Call technician, adjustment required with detent on valve.	Make sure machine is off and call hydraulic technician.
Control handle doesn't go to neutral when released.	Control may be damaged.	Call technician, control may need service or be replaced.	Make sure machine is off and call hydraulic technician.
Cylinder stops on contact with wood.	Second stage on pump not functioning.	Call technician, pump may need service or be replaced.	Make sure machine is off and call hydraulic technician.
Wedge jumps.	Wedge frame jamming.	Lubricate wedge frame wear plates.	Make sure machine is off.
Leaking hydraulic hose.	Hose worn or damaged.	Replace hose.	Make sure machine is off and cooled down.
Leaking cylinder.	Seals worn.	Call technician, seal replacement may be required.	Make sure machine is off and call hydraulic technician.
Engine related issues.	Refer to your engine instruction manual for specific trouble shooting instructions / requirements.		

11. Specifications

Model	WP240	WP270
Recommended Minimum Power	45 hp (33.1 kW)	45 hp (33.1 kW)
Recommended Pump Flow	12–24 US gpm (45–91 Lpm)	
Cylinder Diameter / Stroke	4.50" / 25.75" (121 mm / 654 mm)	4.50" / 37.75" (121 mm / 959 mm)
Splitter Control Valve Type	Dual Valve Open Centre with Auto Cycle Detent	
Full Stroke Splitting Cycle Time	Varies depending on tractor flow and power	
Splitting Force	20–25 ton / tonne @ 2550–3000 psi	
Maximum Split Length	27" (69 cm)	39" (99 cm)
Maximum Log Diameter	22" (56 cm)	
Wedge Configuration	Adjustable 4-Way	
Mounting	3-Point Hitch Category I, II Mounting	
Weight	1614 lb (732 kg)	1785 lb (810 kg)
Dimensions Extended (L x W x H)	220" x 60" x 66" (559 cm x 152 cm x 168 cm)	244" x 60" x 66" (620 cm x 152 cm x 168 cm)
Dimensions Folded (L x W x H)	126" x 60" x 79" (320 cm x 152 cm x 201 cm)	161" x 60" x 79" (409 cm x 152 cm x 201 cm)
Winch	Hydraulic, Valve Operated Winch	
Winch Rope Length	50' (15.2 m)	
Winch Pulling Force	1550 lb (703 kg)	
Discharge Chute Height	54" (1.4 m) maximum	
Winch Strap	60" (1,5 m)	
Accessories	Adjustable 6-way Wedge Option (2089W572)	
	Nylon Chainsaw Holster (#089A570)	
	48" (1.2 m) Log Peavey (299001)	
	Firewood Net Frame (2089A580)	
	Firewood Net (Z99007)	
	Pivoting Chainsaw Holder (P201)	
	Accessory Hydraulic Pump Kit – 7.1 US gal /27 L (2089A600)	

Specifications subject to change without notice

11.1 Bolt Torque

Checking Bolt Torque

The tables shown give correct torque values for various bolts and capscrews. Tighten all bolts to the torques specified in the table, unless specified otherwise. Check tightness of bolts periodically.

IMPORTANT! If replacing hardware, use fasteners of the same grade.

IMPORTANT! Torque figures indicated in the table are for non-greased or non-oiled threads. Do not grease or oil threads unless indicated otherwise. When using a thread locker, increase torque values by 5%.

 **NOTE:** Bolt grades are identified by their head markings.

Imperial Bolt Torque Specifications						
Bolt Diameter	Torque Value					
	SAE Gr. 2		SAE Gr. 5		SAE Gr. 8	
	lbf•ft	N•m	lbf•ft	N•m	lbf•ft	N•m
1/4"	6	8	9	12	12	17
5/16"	10	13	19	25	27	36
3/8"	20	27	33	45	45	63
7/16"	30	41	53	72	75	100
1/2"	45	61	80	110	115	155
9/16"	60	95	115	155	165	220
5/8"	95	128	160	215	220	305
3/4"	165	225	290	390	400	540
7/8"	170	230	420	570	650	880
1"	225	345	630	850	970	1320



SAE Gr. 2



SAE Gr. 5



SAE Gr. 8

Metric Bolt Torque Specifications				
Bolt Diameter	Torque Value			
	Gr. 8.8		Gr. 10.9	
	lbf•ft	N•m	lbf•ft	N•m
M3	0.4	0.5	1.3	1.8
M4	2.2	3	3.3	4.5
M6	7	10	11	15
M8	18	25	26	35
M10	37	50	52	70
M12	66	90	92	125
M14	83	112	116	158
M16	166	225	229	310
M20	321	435	450	610
M30	1,103	1 495	1,550	2 100



8.8



10.9

11.2 Hydraulic Fitting Torque

Tightening Flare Type Tube Fittings

1. Check flare and flare seat for defects that might cause leakage.
2. Align tube with fitting before tightening.
3. Hand-tighten swivel nut until snug.
4. To prevent twisting the tube, use two wrenches. Place one wrench on the connector body and tighten the swivel nut with the second. Torque to values shown.



If a torque wrench is not available, use the FFFT (Flats From Finger Tight) method.

Hydraulic Fitting Torque							
Tube Size OD	Hex Size Across Flats	Torque value		Flats From Finger Tight			
		Inches	Inches	lbf•ft	N•m	Flats	Turns
3/16	7/16			6	8	2	1/6
1/4	9/16			11–12	15–17	2	1/6
5/16	5/8			14–16	19–22	2	1/6
3/8	11/16			20–22	27–30	1-1/4	1/6
1/2	7/8			44–48	59–65	1	1/6
5/8	1			50–58	68–79	1	1/6
3/4	1-1/4			79–88	107–119	1	1/8
1	1-5/8			117–125	158–170	1	1/8

Values shown are for non-lubricated connections.

12. Accessories

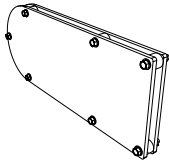
Contact your dealer for pricing and availability

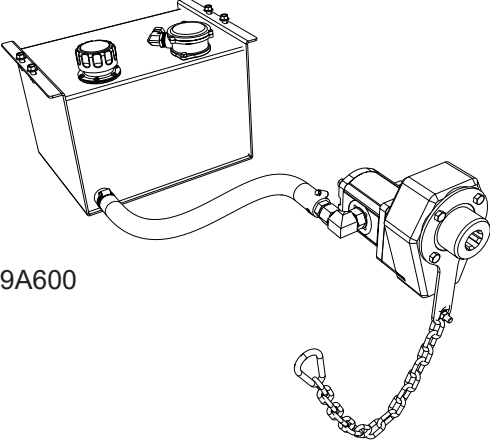
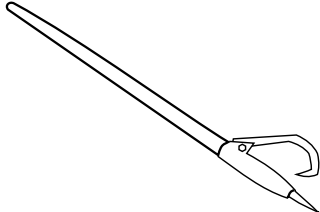
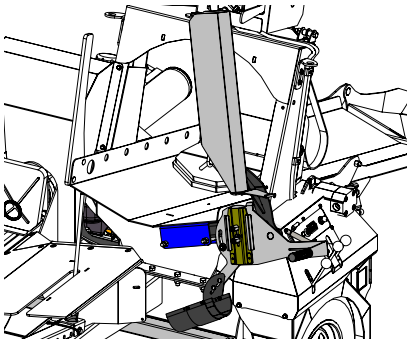
<p>#2089A570</p> 	<p>Nylon Chainsaw Holster For models: WP240, WP270</p> <p>Easy to install, fastens to Wood Processor</p> <p>Nylon holder, safely holds your chainsaw keeping it off the ground and out of the way!</p>
<p>#2089W571</p> 	<p>6-Way Wedge For models: WP240, WP270</p> <p>Easy to install in minutes, and you're ready to go! 6 way splitting wedge, boost your productivity and make quick work out of chunks by splitting into six pieces at once. This is an ideal way to save time</p>
<p>#2089A600</p> 	<p>PTO Hydraulic Power Pack For models: WP240, WP270</p> <p>Installs on your PTO, and you're ready to go!</p> <p>Designed to fit and power your Wood Processor. It features a 7.1 US gal (27 L) reservoir and hydraulic pump rated for 15 gpm (56.8 Lpm) @ 540 rpm.</p>
<p>#299001</p> 	<p>Log Peavey – 48" (1.2 m)</p> <p>Helps to move those heavy log timbers into position, and finish getting your last logs through the Wood Processor!</p>
<p>#P200</p> 	<p>Pivoting Chainsaw Holder For all WP Series</p> <p>The pivoting chain saw holder securely holds your saw in place allowing for easier cutting and saving time handling your chainsaw. Easily mounts to most chain saws.</p> <div style="border: 1px solid black; padding: 5px;"> <p>Available: P210 Spare Pivoting Chainsaw Adaptor</p> <p>Save time switching out chainsaws with a spare adaptor for your second chainsaw!</p> </div>

13. Alphabetical Index

	A			
Accessories.....		54		
Adjustable Log Length Guide.....		28		
Attaching / Unhooking.....		30		
Auto Cycle.....		26		
	B			
Bolt torque.....		52		
Break-in.....		25		
	C			
Chainsaw Safety.....		15		
Checking Bolt Torque.....		52		
Controls.....		26		
Adjustable Log Length Guide.....		28		
Attaching / Unhooking.....		30		
Hydraulic Controls and Auto Cycle.....		26		
Splitter Chute Height Adjuster.....		29		
Winch Gear Lever.....		27		
Cutting.....		39		
	D			
Delivery Inspection Report.....		4		
	E			
Efficient Processing.....		41		
Emergency.....		34		
Emergency Stopping.....		34		
Equipment Safety Guidelines.....		10		
	F			
Familiarization.....		22		
Equipment Condition.....		23		
Job Site Familiarization.....		23		
Machine Components.....		23		
Operator Orientation.....		22		
To the New Operator.....		22		
Training.....		23		
	H			
Hearing loss.....		12		
Holster.....		54		
Hydraulic.....		47, 49		
Hydraulic Fitting Torque.....		53		
Hydraulic System Safety.....		12		
	I			
Informative Labels.....		6		
Introduction.....		7		
	L			
Label Information.....		6		
Last log.....		41		
Lever 1.....		26		
Lever 2.....		26		
	M			
Machine Break-In.....		25		
Machine Set-Up.....		35		
Maintenance Labels.....		6		
Maintenance Safety.....		45		
Maintenance Schedule.....		48		
	N			
Next Log.....		40		
	O			
Operating safety.....		33		
Operating Safety.....		13		
Operation.....		33		
Machine Set-Up.....		35		
Pre-Operation Checklist.....		25		
Operator Orientation.....		22		
Optional Power Pack.....		49		
	P			
Peavey.....		54		
Personal Protective Equipment (PPE).....		9		
Power Pack.....		32		
PPE.....		9		
Pre-Operation Checklist.....		25		
Processing Operation.....		38		
Position the Log.....		39		
Winching.....		38		
Wood Discharge.....		42		
Product Labels.....		6		
Pull Angle.....		41		
	S			
Safe Condition.....		9, 11, 15		
Safe Condition Procedure.....		22		
Safety.....		8		
Chainsaw Safety.....		15		
Equipment Safety Guidelines.....		10		
General.....		9		
How to Install Safety Signs.....		22		
Hydraulic System Safety.....		12		
Maintenance Safety.....		15		
Operating Safety.....		13		
Personal Protective Equipment (PPE).....		9		
Preparation.....		12		
Replace Damaged Safety Signs.....		22		
Safety Alert Symbol.....		8		
Safety Do's and Don'ts.....		9		
Safety Sign Explanations.....		21		
Safety Sign Locations.....		20		
Safety Training.....		11		
Signal Words.....		8		
Storage Safety.....		15		
Transport Safety.....		14		
Winching Safety.....		17		
Wood Processing Safety.....		16		

Safety Alert Symbol.....	8
Safety Do's and Don'ts.....	9
Safety Notice Labels.....	6
Safety Sign Explanations.....	21
Safety Sign Locations.....	20
Safety Signs.....	20
Safety Training.....	11
Serial number.....	5
Service and Maintenance.....	45
Fluids and Lubricants.....	45
Greasing.....	46
Maintenance Schedule.....	48
Sign-off form.....	18
Specifications.....	51
Hydraulic Fitting Torque.....	53
Splitter Chute Height Adjuster.....	29
Splitting.....	40
Starting.....	34
Stopping.....	34
Storage.....	44
Be Prepared.....	33
Placing Wood Processor in Storage.....	44
Removing From Storage.....	44
Storage Safety.....	15, 44

T

Transporting.....	43
Transport Safety.....	43
Transport Safety.....	14
Troubleshooting.....	50

W

Warranty.....	3
Wedge.....	28, 54
Winch.....	27
Winch Gear Lever.....	27
Winching.....	38
Winching Safety.....	17
Wood Processing Safety.....	16



A series of 20 horizontal lines spaced evenly down the page, providing a template for writing.



A series of 20 horizontal lines spaced evenly down the page, providing a template for writing.



A series of 20 horizontal lines spanning the width of the page, providing a template for writing.



www.wallensteinequipment.com