

# OPERATOR'S MANUAL

---

Serial numbers 2E9US1115LS051036 to 2E9US1119MS051055

## **BXTR5224** **Trailer Wood Chipper**

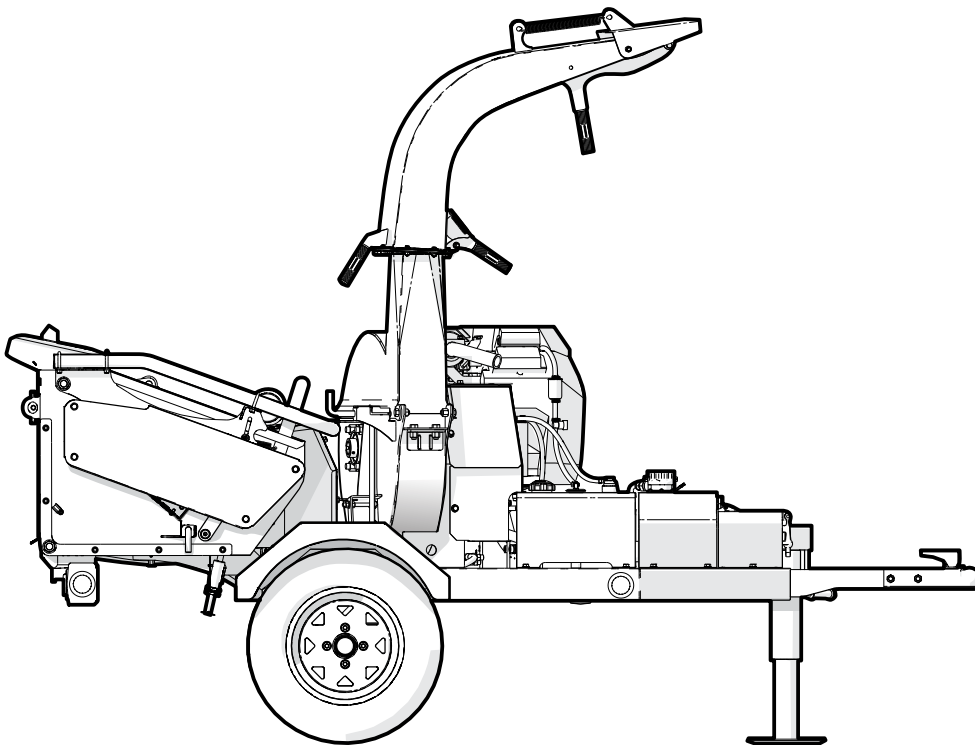

---

Rev Apr-2021

Part Number: Z97129\_En

**WALLENSTEIN**

# 1. Foreword

## 1.1 Introduction

Congratulations on choosing the Wallenstein **BXTR5224 Trailer Wood Chipper!**

This machine is designed and manufactured to meet the needs of the timber and landscaping industries, as well as township and municipal requirements.

**Review all safety, operation and maintenance information contained in this manual.**

Safe, efficient and trouble-free operation of this Wallenstein product requires that anyone using or maintaining the machine reads and understands the Safety, Operation, Maintenance information contained within the Operator's Manual.

Keep this manual handy for frequent reference and to pass on to new operators or owners. Call your Wallenstein dealer or the distributor if you need assistance, information or additional copies of the manuals.

Units of measurement in Wallenstein Equipment technical manuals are written as:  
US Customary (SI metric)

Keep this manual handy for reference. Pass it on to new operators or owners. Call your Wallenstein dealer or the Distributor if you need assistance, information or additional copies of this manual.



### WARNING!

**Do not attempt to start or operate the machine without thoroughly reviewing this manual for safe and proper operation.**

**Always keep this manual with the machine.**

W034

**Wallenstein Equipment Inc. • © 2021. All rights reserved.**

No part of this work may be copied, reproduced, replaced, distributed, published, displayed, modified, or transferred in any form or by any means except with the prior permission of Wallenstein Equipment Inc.



[www.wallensteinequipment.com](http://www.wallensteinequipment.com)

## Table of Contents

<b>1. Foreword</b> .....	<b>2</b>	<b>6. Service and Maintenance</b> .....	<b>43</b>
1.1 Introduction .....	2	6.1 Maintenance Safety .....	43
1.2 Delivery Inspection Report.....	4	6.2 Fluids and Lubricants.....	43
1.3 Serial Number Location .....	5	6.3 Maintenance Schedule .....	44
1.4 Types of Decals on the Machine .....	6	6.4 Grease Points .....	45
<b>2. Safety</b> .....	<b>7</b>	6.5 BXTR5224 Hydraulic Circuit.....	47
2.1 Safety Alert Symbol .....	7	6.6 Hydraulic Oil – Changing .....	48
2.2 Signal Words .....	7	6.7 Engine Air Cleaner.....	49
2.3 Why SAFETY is Important.....	7	6.8 Servicing the Battery .....	50
2.4 Safety Rules .....	8	6.9 Hydraulic Pump Drive Belt Replacement.....	51
2.5 Equipment Safety Guidelines .....	8	6.10 Pump Drive Belt Tension .....	51
2.6 Safety Training.....	8	6.11 Rotor Drive Belt Replacement .....	52
2.7 Be Prepared.....	9	6.12 Sheave Alignment.....	52
2.8 Operating Safety.....	9	6.13 Rotor Drive Belt Tension.....	52
2.9 Feed Roller Safety .....	10	6.14 Upper Feed Roller Tension Adjustment.....	53
2.10 Transport Safety .....	10	6.15 Rotor Blades – Changing.....	53
2.11 Refueling Safety .....	10	6.16 Ledger Knife – Checking .....	54
2.12 Tire Safety .....	10	6.17 Ledger Knife – Changing .....	55
2.13 Battery Safety .....	10	6.18 Twig Breaker.....	55
2.14 Hydraulic Safety.....	11	6.19 Fuel Filter – Changing .....	56
2.15 Gas Engine Safety.....	11	6.20 Electrical System – General .....	56
2.16 Sign-Off Form .....	13	6.21 Troubleshooting .....	57
2.17 Safety Sign Explanations.....	14	<b>7. Specifications</b> .....	<b>59</b>
<b>3. Familiarization</b> .....	<b>19</b>	7.1 Bolt Torque .....	60
3.1 To the New Operator or Owner .....	19	7.2 Hydraulic Fitting Torque.....	61
3.2 Job Site Familiarization.....	19	7.3 Wheel Lug Torque .....	61
3.3 Operator Orientation .....	19	<b>8. Product Warranty</b> .....	<b>62</b>
<b>4. Controls</b> .....	<b>21</b>	<b>9. Alphabetical Index</b> .....	<b>63</b>
4.1 Engine Controls .....	21		
4.2 Discharge Chute .....	22		
4.3 Hood Deflector.....	22		
4.4 Feed Roller Control Bar .....	23		
4.5 P3 PULSE Electronic Control System .....	25		
4.6 Ladder Hitch Kit .....	32		
4.7 Clean-out Tray .....	32		
<b>5. Operating Instructions</b> .....	<b>33</b>		
5.1 Before Startup.....	33		
5.2 Pre-operation Checks .....	33		
5.3 Machine Break-In.....	34		
5.4 Fuel Level Check.....	34		
5.5 Engine Oil Level Check .....	35		
5.6 Hydraulic Oil Level Check.....	35		
5.7 Machine Setup.....	36		
5.8 Starting the Engine .....	37		
5.9 Stopping Procedure .....	37		
5.10 Stopping in an Emergency.....	37		
5.11 Chipping Operation .....	38		
5.12 Unplugging the Chipper .....	39		
5.13 Transporting.....	41		
5.14 Storage .....	42		

## 1.2 Delivery Inspection Report

### Wallenstein BXTR5224 Trailer Wood Chipper

To activate warranty, register your product at: [www.wallensteinequipment.com](http://www.wallensteinequipment.com)

This form must be filled out by the dealer at the time of delivery, then signed by the dealer and customer.

The product manuals have been received by me and I have been thoroughly instructed as to care, adjustments, safe operation, and applicable warranty policy.

I have thoroughly instructed the buyer on the equipment care, adjustments, safe operation and applicable warranty policy and reviewed the manuals.

\_\_\_\_\_  
Customer

\_\_\_\_\_  
Address

\_\_\_\_\_  
City, State/Province, ZIP/Postal Code

(        )  
\_\_\_\_\_  
Phone Number

\_\_\_\_\_  
Contact Name

\_\_\_\_\_  
Model

\_\_\_\_\_  
Serial Number

\_\_\_\_\_  
Delivery date

\_\_\_\_\_  
Dealer

\_\_\_\_\_  
Address

\_\_\_\_\_  
City, State/Province, ZIP/Postal Code

(        )  
\_\_\_\_\_  
Phone Number

### 1.2.1 Dealer Inspection Report

- \_\_\_\_\_ Engine Oil Level Checked
- \_\_\_\_\_ Engine Starts and Runs
- \_\_\_\_\_ Check Blade Clearance
- \_\_\_\_\_ Rotor Turns Freely
- \_\_\_\_\_ Belt Tension Correct
- \_\_\_\_\_ Engine / Rotor Sheaves Aligned
- \_\_\_\_\_ Lubricate Grease Points
- \_\_\_\_\_ All Fasteners Tight
- \_\_\_\_\_ Pivot points lubricated.
- \_\_\_\_\_ Tire Pressure Checked
- \_\_\_\_\_ P3 PULSE Display Function

#### Safety Checks

- \_\_\_\_\_ All Safety Decals Installed
- \_\_\_\_\_ Guards and Shields Installed / Secured
- \_\_\_\_\_ Retainer Installed through Hitch Points
- \_\_\_\_\_ Safety Chain on Hitch
- \_\_\_\_\_ Check Wheel Lug Torque
- \_\_\_\_\_ Check Operation of Running / Brake / Turn Signal Lights

## 1.3 Serial Number Location

Always provide the serial number of your Wallenstein product when ordering parts or requesting service or other information. The Serial Number Plate location is shown in the illustration.

**Record the product Serial Number in the space provided below for future reference.**

Record Product Information Here	
Model:	<b>BXTR5224</b>
Serial Number:	

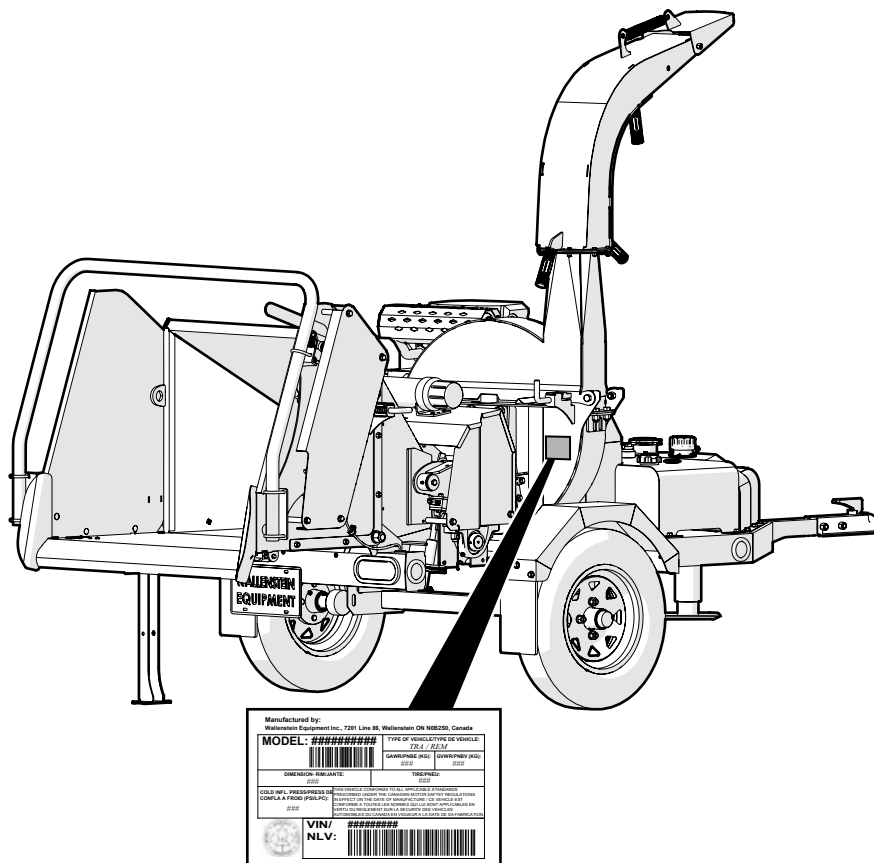

00167

Fig. 1 – Serial Number Plate Location

## 1.4 Types of Decals on the Machine

When getting familiar with the Wallenstein product, notice that there are numerous decals located on the machine. There are different types of decals for safety, information, and product identification. The following section explains what they are for and how to read them.

**Safety Decals** have a yellow background and are generally two panel. They can be either vertical or horizontal.

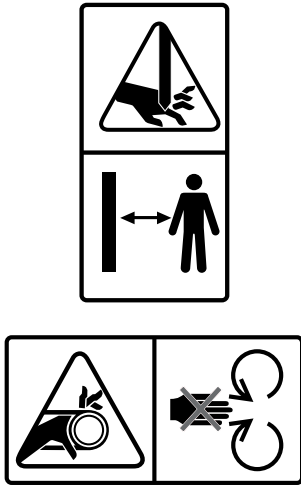

**Safety Notice Decals** are pictorial with a blue background and generally rectangular with single or multiple symbols. This decal informs what Personal Protective Equipment is required for safe operation.



**Informative Decals** are generally pictorial with a white background and can vary in the number of panels. This type of decal explains how a control works.

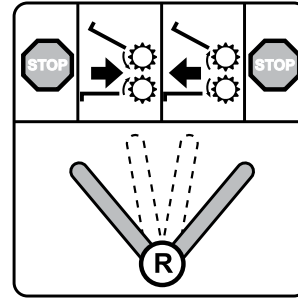

**Product Decals** indicate machine model and serial number, and other important information.

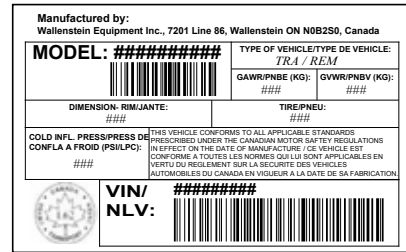

**Maintenance Decals** have a green background and can vary to the number of panels. This decal shows a type maintenance required and frequency interval.

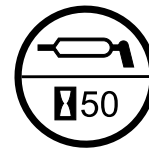

See the section on safety signs for safety decal definitions. For a complete illustration of decals and decal locations, download the parts manual for your model product at [www.wallensteinequipment.com](http://www.wallensteinequipment.com).

## 2. Safety

### 2.1 Safety Alert Symbol

This Safety Alert Symbol means:

**ATTENTION! BE ALERT!**

**YOUR SAFETY IS INVOLVED!**

The **Safety Alert Symbol** identifies important safety messages on the Wallenstein wood chipper and in the manual. When you see this symbol, be alert to the possibility of personal injury or death. Follow the instructions in the safety message.



### 2.2 Signal Words

The signal words **DANGER**, **WARNING** and **CAUTION** determine the seriousness level of the warning messages in this manual. The appropriate signal word for each message in this manual has been selected using the following guidelines:

#### **DANGER –**

Indicates an imminently hazardous situation that, if not avoided, **will** result in death or serious injury. This signal word is to be limited to the most extreme situations typically for machine components which, for functional purposes, cannot be guarded.

#### **WARNING –**

Indicates a potentially hazardous situation that, if not avoided, **could** result in death or serious injury, and includes hazards that are exposed when guards are removed. It may also be used to alert against unsafe practices.

#### **CAUTION –**

Indicates a potentially hazardous situation that, if not avoided, **may** result in minor or moderate injury. It may also be used to alert against unsafe practices.

**IMPORTANT** – To avoid confusing equipment protection with personal safety messages, a signal word **IMPORTANT** indicates a situation that if not avoided, could result in damage to the machine.

### 2.3 Why SAFETY is Important

#### Three Big Reasons:

- **Accidents Disable and Kill**
- **Accidents Cost**
- **Accidents Can Be Avoided**

The policy of Wallenstein Equipment Inc. is to produce products that are safe and reliable. However, even when using well-engineered equipment, there is always an element of risk. To minimize the risks and promote safety at all times, this section of the operator's manual details a number of safety rules that must always be followed and obeyed.

**YOU** are responsible for the **SAFE** operation and maintenance of your Wallenstein Trailer Wood Chipper. **YOU** must ensure that you and anyone else who is going to use, maintain or work around the wood chipper be familiar with the operating and maintenance procedures and related safety information contained in this manual. This manual provides good safety practices that should be followed while using the wood chipper.

Remember, **YOU** are the key to safety. Good safety practices not only protect you but also the people around you. Make these practices a working part of your safety program. Be certain that **EVERYONE** using this equipment is familiar with the recommended use and maintenance procedures and follows all the safety precautions.

**Do not risk injury or death by ignoring good safety practices.**

## 2.4 Safety Rules

- **DO** give operating instructions to operators or employees before allowing them to operate the machine, and **REVIEW** annually thereafter.

- **DO** read and understand ALL Safety and Operating instructions in the manual and follow them. The most important safety device on this equipment is a **SAFE** operator.



- **DO** review safety related items annually with all personnel who are operating the machine or performing maintenance.

- **DO** wear appropriate Personal Protective Equipment (PPE). The suggested equipment includes but is not limited to the following:

- Hearing Protection
- Protective glasses, goggles or face shield
- Heavy work gloves

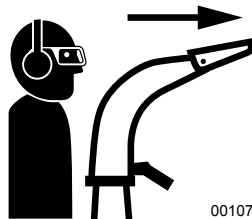

00107

- **DO** have a first-aid kit available for use should the need arise and know how to use it.



- **DO** read and understand all safety signs located on the machine before operating, servicing, adjusting, or cleaning.

- **DO** inspect and secure all guards before starting.

- **DO** check input and discharge chutes, engine intake and exhaust. Make sure they are clear of debris prior to starting the machine.

- **DO** inspect and secure all guards before starting.

- **DO** have a fire extinguisher available for use should the need arise. Know how to use it.

- **DO** think SAFETY! Work SAFELY!



- **DO NOT** touch hot engine parts, muffler cover, hydraulic hoses, engine body, engine oil, and so on during operation or if the engine was recently shut off. Contact may cause burns.

- **DO NOT** expect a person who has not read and understood all operation and safety instructions to use the machine. An untrained operator is not qualified and is exposed to possible serious injury or death. It is the owner's responsibility to make sure the operator has familiarity and understanding of the machine.

- **DO NOT** modify, disable or change the roller feed safety / control bar in any way.

- **DO NOT** allow riders during transport.

- **DO NOT** risk injury or death by ignoring good safety practices.

## 2.5 Equipment Safety Guidelines

- Always place the machine in a safe service position before performing any service work, maintenance procedures, or storage preparation. The **Safe Condition** is as follows:

### SAFE CONDITION

- Shut off engine. Remove ignition key.
- Make sure all moving parts have stopped.
- Disconnect battery ground (-) cable.
- Block or chock wheels.

- Never use equipment with safety shields removed. Keep all shields in place. If shield removal becomes necessary for repairs, reinstall the shield prior to use.
- Replace any safety sign or instruction sign that is not readable or is missing. Location of safety signs is indicated in this manual.
- Do not allow anyone other than a responsible, properly trained and physically able person to operate this machine. This equipment is dangerous to children and persons unfamiliar with its operation.
- Do not modify the equipment in any way. Unauthorized modification may result in serious injury or death and may impair the function and life of the equipment.
- Never exceed the limits of the machine. If its ability to do the job or to do it safely is in question—**STOP IMMEDIATELY!**

## 2.6 Safety Training

- The best safety feature is an informed, careful operator—we ask you be that kind of operator. It is the operator's responsibility to read, understand and follow ALL safety and operation instructions in the manual.





- Train all new personnel and review instructions frequently with existing workers. Only properly trained and physically able operators should use this equipment. **A person who has not read and understood all operation and safety instructions is not qualified to use the machine.** Untrained operators expose themselves and bystanders to possible serious injury or death. If elderly people are assisting with the work, their physical limitations need to be recognized and accommodated.
- Learn the controls and how to stop the machine quickly in an emergency.
- If this machine is loaned or rented, it is the machine owner's responsibility to make certain that every operator:
  - reads and understands the owner's manual
  - is instructed in safe and proper use of the equipment
  - understands and knows how to perform the Safe Condition procedure

## 2.7 Be Prepared

- Wear appropriate personal protective equipment. Tie back long hair, remove jewelry, and avoid loose fitting clothing. Prolonged exposure to loud noise can cause permanent hearing loss! Wear hearing protection on a full-time basis when using this machine.
- Keep bystanders at safe distance at least 20 ft (6 m) from work zone. Mark the zone with safety cones.
- Determine where chips are piled and ensure the location does not interfere with safe operation of the machine.
- Determine a safe work area location:
  - area must be clear of stones, branches or hidden obstacles that might cause a tripping, hooking or snagging hazard
  - ground should be firm and level
- Be aware of overhead hazards such as branches, cables, or electrical wires.
- Operate only in daylight or good artificial light.
- Make sure machine is properly adjusted and in good operating condition.
- Store fuel well away from the material pile.
- Perform the **Pre-operation Checks** procedure before starting work (see *page 33*).

## 2.8 Operating Safety

Read and obey the safety signs on the machine. Clean or replace them if they are not legible.

There is no substitute for a cautious, safe-minded operator who recognizes potential hazards and follows reasonable safety practices. This machine must be used with all its safety equipment properly installed to minimize the chance of accidents.

- When operating this equipment always have at least two workers present and trained in safe operation of the machine.
- The operator must be in control of the machine at all times. The spotter must remain out of the danger zone while the machine is in operation. Bystanders must remain in the safe zone.
- Do not overreach into the hopper. Keep proper balance and footing at all times.
- Feed rollers can cause serious injury or death. Keep hands, feet and clothing away from the feed roller.
- Never allow anyone to sit on the feed table.
- Do not put metal objects, bottles, cans, rocks, glass or other foreign material into wood chipper. If such items happen to get into the chipper, stop machine and turn engine off. Wait for all moving parts to stop before removing material. Inspect machine for damaged or loose parts before resuming work.
- Make sure all guards, deflectors and shields are in place before starting and operating.
- Read and understand owner's manual before starting. Review safety instructions annually.
- Personal protective equipment is recommended during assembly, installation, operation, adjustment, maintaining, repairing, removal, or moving. Do not allow long hair, loose-fitting clothing, or jewelry to be around moving parts.
- Do not allow anyone within the work or danger zone during operation. Ejected wood chips can cause injuries. Keep children away.
- Never place any part of your body where it would be in danger if machine movement should occur during assembly, installation, operation, maintenance, repairing, unplugging or moving.
- Inspect electrical harness, sensors and controller to make sure they are in good condition before operating.
- Before servicing or repairing the machine, place it in a **Safe Condition**. See *page 8*.
- Do not operate on hillsides or when working area is cluttered, wet, muddy or icy to prevent slipping and tripping. Operate only on level ground.
- Position machine so prevailing winds blow engine exhaust fumes away from operator's station.
- Never use engine-powered machinery indoors. Gas engine exhaust contains toxic carbon monoxide, which cannot be smelled or seen. Breathing carbon monoxide can be lethal.

- Stop engine when leaving the machine unattended.

## 2.9 Feed Roller Safety

- Do not overreach into the hopper. Keep proper balance and footing at all times.
- Feed rollers can cause serious injury or death. Keep hands, feet and clothing away.
- Never climb onto the feed table or hopper when the chipper is operating or running.
- Never allow anyone to sit on the feed table.

## 2.10 Transport Safety

- Comply with local laws governing safety and transporting of machinery on public roads.
- Do not exceed 50 mph (80 km/h) when towing this machine. Slow down for rough terrain and cornering.
- Do not transport or move the wood chipper with the engine running.
- Ensure all latch handles are secure.
- Be sure the trailer is hitched correctly to the towing vehicle and a retainer is used through the hitch mechanism.
- Always attach safety chains between the hitch and the towing vehicle. Cross the chains underneath the trailer tongue.
- Check wheel lugs and tighten if required. Inspect rims for damage.
- Inspect tires for cuts or damage. Check tire pressure and adjust if required.
- Ensure the stability jacks are raised and secured with the latch pin.
- Make sure tow vehicle is fitted with the correct size (2 in) towing ball.
- Inspect all access panels and guards to ensure they are secured.
- Make sure fuel and hydraulic tank caps are on tight to prevent spills while transporting.
- Clean all debris off the chipper. Remove any tools or other loose items.
- Check that all the lights, reflectors and other lighting requirements are installed and in good working condition.
- Never allow riders on the machine.
- Be a safe and courteous driver. Always yield to oncoming traffic in all situations, including narrow bridges, intersections, and so on.
- Watch for other traffic when near or crossing roadways.
- Do not drink and drive.

- Before transporting, perform a walk-around inspection to ensure everything is safe.

## 2.11 Refueling Safety

- Engine fuel is highly flammable. Handle with care.
- Fill fuel tank outdoors.
- Stop the engine before refueling. Allow engine to cool for five minutes. Clean up spilled fuel before restarting engine.
- Do not overfill the fuel tank.
- If fuel is spilled, wipe it away carefully and wait until the fuel has dried before starting the engine.
- Do not refuel the machine while smoking or when near open flame or sparks.
- After refueling, make sure that the fuel cap is secured to prevent spillage.
- Prevent fires by keeping machine clean of accumulated trash, grease, and debris.



## 2.12 Tire Safety

- Failure to follow proper procedures when mounting a tire on a wheel or rim can produce an explosion which may result in serious injury or death.
- Do not attempt to mount a tire unless you have the proper equipment and experience to do the job.
- Have a qualified tire dealer or repair service perform required tire maintenance.
- When replacing worn tires, make sure they meet the original tire specifications. Never install undersized tires.

## 2.13 Battery Safety



**Risk of burns! Battery electrolyte is extremely corrosive and poisonous. Contact with the eyes, skin, or clothing can result in severe burns or other serious personal injury. If contact occurs seek medical attention immediately. Handle batteries carefully.**

W020

- Wear gloves and safety glasses or face shield when working on or near batteries.
- Use a battery carrier to lift the battery or place hands at opposite corners to avoid spilling acid through the vents.

- Avoid contact with battery electrolyte:
  - **External Contact:** Flush immediately with water.
  - **Eye Contact:** Flush with water for 15 minutes. Get prompt medical attention. Clean up any spilled electrolyte immediately.
- Avoid contact with battery posts, terminals and related accessories, they contain lead and lead compound chemicals known to cause harm if ingested. Wash hands immediately after handling battery.
- Keep all sparks and flames away from batteries. Electrolyte fumes are explosive.
- To avoid injury from spark or short circuit, disconnect battery ground cable before servicing any part of the electrical system.

 **CAUTION!**

**Risk of explosion or fire! Do not let metal objects come in contact with the battery terminals. Arcing can cause a fire or explosion. Cover terminals if working near batteries.**

W021

- Do not jump start or charge a frozen battery. Frozen batteries can explode and result in death or serious injury. Let battery thaw before charging.

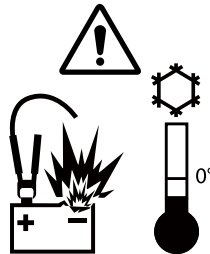

## 2.14 Hydraulic Safety

- Make sure that all the components in the hydraulic system are kept in good condition and are clean.
- Before applying pressure to the system, make sure all components are tight, and that lines, hoses and couplings are not damaged.
- Do not attempt any makeshift repairs to the hydraulic lines, fittings or hoses by using tapes, clamps or cements. The hydraulic system operates under extremely high pressure. Such repairs can fail suddenly and create a hazardous and unsafe condition.
- Wear proper hand and eye protection when searching for a high pressure hydraulic leak. Use a piece of wood or cardboard as a backstop instead of hands to isolate and identify a leak.

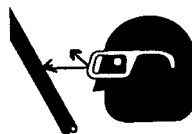

- If injured by a concentrated high-pressure stream of hydraulic fluid, seek medical attention immediately. Serious infection or toxic reaction can develop from hydraulic fluid piercing the skin surface.
- Relieve pressure in the hydraulic system before working on it.

## 2.15 Gas Engine Safety

 **CAUTION!**

**Before starting engine, review the operating and maintenance instructions in the engine manual.**

W019

- **DO NOT** operate engine in an enclosed area. Exhaust gases contain odorless and deadly carbon monoxide that can cause death by asphyxiation.
- **DO NOT** place hands or feet near moving or rotating parts.
- **DO NOT** store, spill, or use gasoline near an open flame, or devices such as a stove, furnace, or water heater which use a pilot light or devices which can create a spark.
- **DO NOT** refuel indoors where area is not well ventilated.
- **DO NOT** refuel while engine is running. Allow engine to cool for five minutes before refueling. Store fuel in approved safety containers.
- **DO NOT** remove fuel tank cap while engine is running.
- **DO NOT** operate engine if gasoline is spilled. Move machine away from the spill and avoid engine ignition until gasoline has evaporated.
- **DO NOT** smoke while filling fuel tank.
- **DO NOT** choke carburetor to stop engine. Whenever possible, gradually reduce engine speed before stopping.
- **DO NOT** run engine above rated speeds. This may result in injury.
- **DO NOT** tamper with governor springs, governor links or other parts which may increase the governed speed.
- **DO NOT** tamper with the engine as set by the original equipment manufacturer.
- **DO NOT** check for spark with spark plug or spark plug wire removed.
- **DO NOT** crank engine with spark plug removed. If engine is flooded, crank until engine starts.
- **DO NOT** strike flywheel with a hard object or metal tool as this may cause flywheel to shatter in operation. Use proper tools to service engine.
- **DO NOT** operate engine without a muffler. Inspect periodically and replace, if necessary.

- **DO NOT** operate engine with an accumulation of grass, leaves, dirt or other combustible materials in the muffler area.
- **DO NOT** use this engine on any forest covered, brush covered, or grass covered unimproved land unless a spark arrester is installed on the muffler. The arrester must be maintained in effective working order by the operator. In the state of California, the above is required by law (Section 4442 of the California Public Resources Code). Other states may have similar laws. Federal laws apply on federal land.
- **DO NOT** touch hot muffler, engine body or cooling fins. Contact may cause burns.
- **DO NOT** run engine with air cleaner or air cleaner cover removed.

**Be sure to:**

- Remove the wire from the spark plug when servicing the engine or equipment to prevent accidental starting. Disconnect the ground (-) wire from the battery terminal.
- Keep engine cooling fins and governor parts free of grass and other debris that can affect engine speed.
- Examine muffler periodically to be sure it is functioning effectively. A worn or leaking muffler should be repaired or replaced as necessary.
- Use fresh gasoline. Old fuel can clog carburetor and cause leakage.
- Check fuel lines and fittings frequently for cracks or leaks. Replace if necessary.

## 2.16 Sign-Off Form

Anyone using this machine must read and thoroughly understand all Safety, Operation and Maintenance information in this manual. An untrained operator should never use this machine.

To help document this training, the sign-off sheet provided below can be used.

Make periodic reviews of Safety and Operation a standard practice for all operators. Review again at the startup of every season.

The design and manufacture of this product conforms to relative provisions in the following standards:

ISO 4254-1 Agricultural machinery – Safety

ASABE S318 Safety for Agricultural Field Equipment

ISO 3600 Operator’s Manual – Machinery for Agriculture, Forestry & Lawn Equipment

Sign-off Form		
Date	Owner	Employee

## 2.17 Safety Sign Explanations

The top (or left-hand) panel shows the safety alert (the potential hazard), and the bottom (or right-hand) panel shows the message (how to avoid the hazard).

Practicing good safety means becoming familiar with safety signs and warnings and being aware of the situations that require alertness.

**Think SAFETY! Work SAFELY!**

Safety

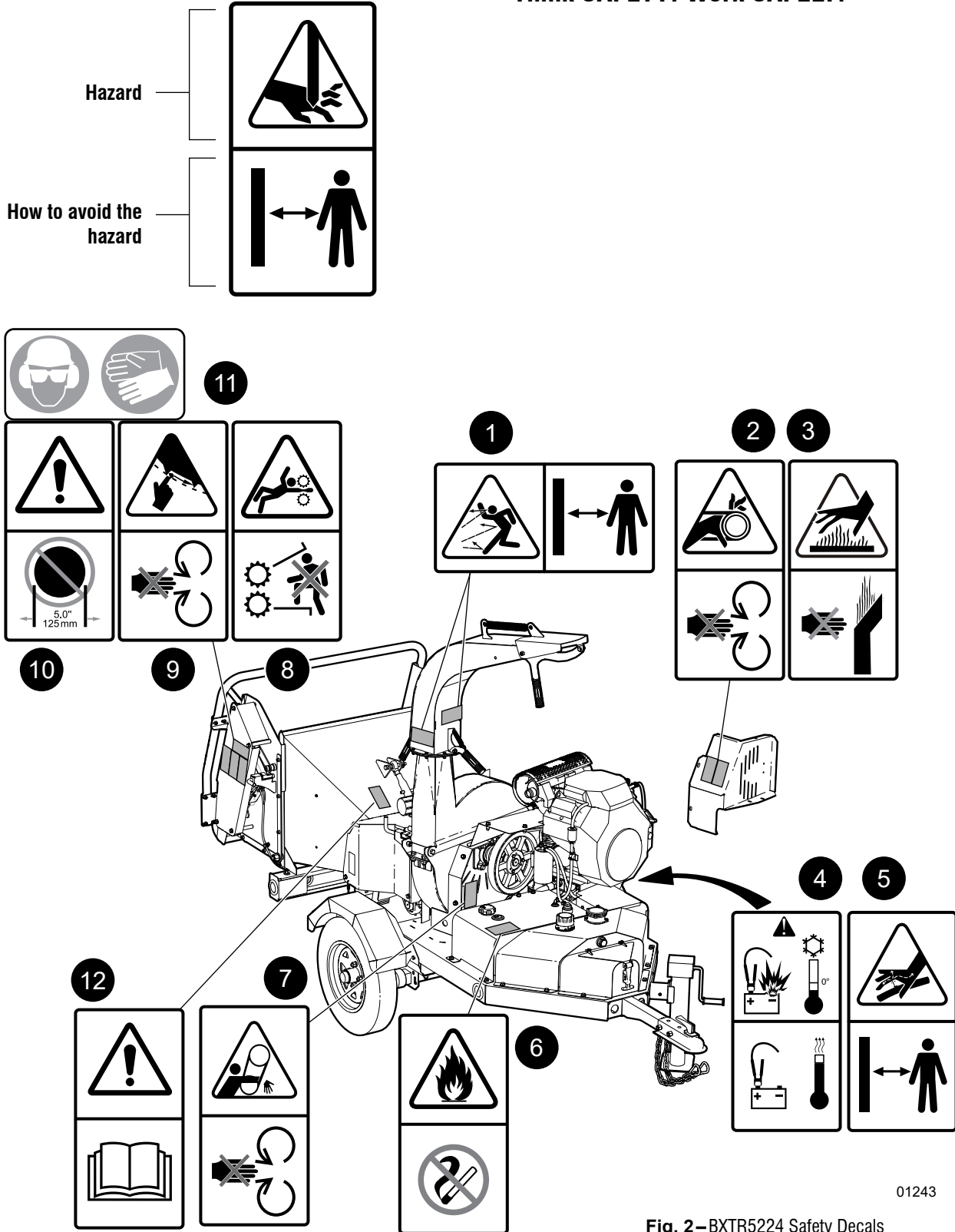

01243

Fig. 2 – BXTR5224 Safety Decals

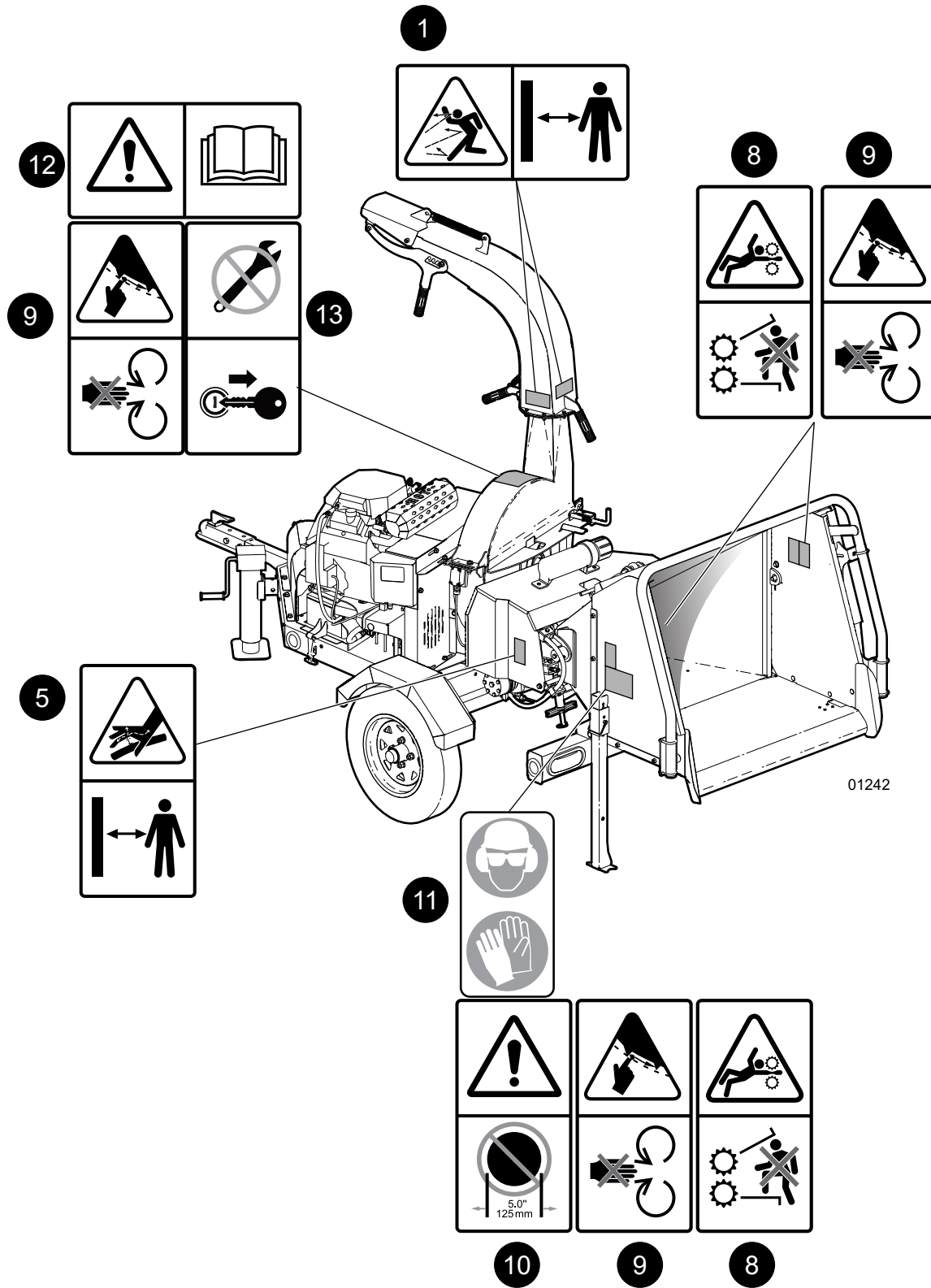

Fig. 3 – BXTR5224 Safety Decals

**1. Caution!**

Risk of injury from flying objects. Stay clear of material discharge chute. Machine can expel wood chips fast enough to cause injury.

Do not point discharge at people, animals, or buildings.



**2. Warning!**

Rotating parts are exposed or under a guard. Do not attempt to reach in while parts are rotating.

Keep hands, loose clothing, and long hair away. Serious injury can result.

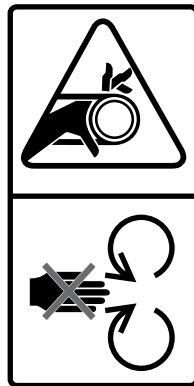

**3. Warning!**

Risk of burns to exposed skin from hot surfaces.

Stay clear of hot exhaust system.

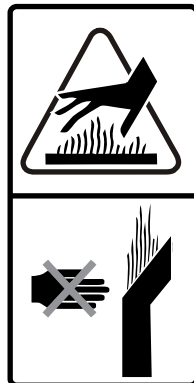

**4. Warning!**

Risk of explosion.

Do not jump start / charge a frozen battery. Frozen batteries can explode and result in serious injury. Let battery thaw before charging.

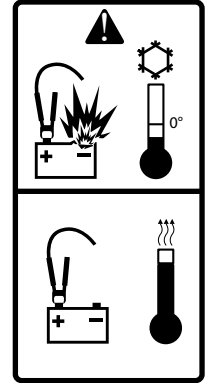

**5. Warning!**

Risk of high pressure hydraulic fluid piercing exposed skin.

Do not check for leaks with hand or fingers. Serious injury can result.



**6. Warning!**

Risk of explosion.

Do not refuel the machine while smoking or near open flame or sparks. Serious injury can result.





### 7. Caution!

Risk of serious injury or death if hands or limbs are caught in rotating parts.

Do not operate machine without shields in place. If shield is removed, replace it before operating machine.

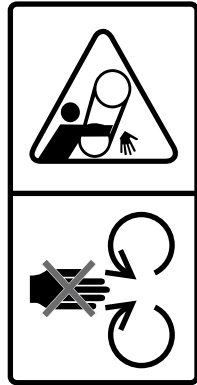

### 8. Warning!

Risk of serious injury or death if hands or limbs are caught in rotating parts.

Do not attempt to reach in while parts are turning. Keep hands, loose clothing, and long hair away.

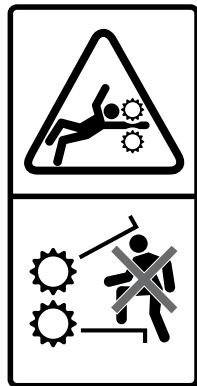

### 9. Warning!

Risk of serious injury. Keep hands and feet out of inlet and discharge openings while machine is operating.

Wait for all moving parts to come to a complete stop before clearing obstructions.

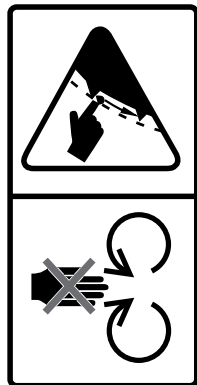

### 10. Caution!

Risk of personal injury or equipment damage.

Do not put material larger than 5.0" (125 mm) diameter into the chipper. Attempting to chip anything larger could stall the engine, damage the machine or cause personal injury.



### 11. Warning!

Personal Protective Equipment (PPE) is required when operating this machine.

- A hard hat
- Hearing protection
- Protective glasses, goggles or face shield
- Protective shoes with slip resistant soles
- Heavy gloves



Failure to wear PPE can result in personal injury.

### 12. Caution!

Refer to the operator's manual. Read ALL operating instructions in the manual and learn the meaning of ALL safety signs on the machine.

The best safety feature is an informed operator.

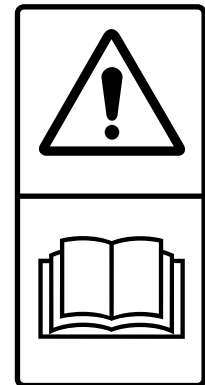

### 13. Caution!

Risk of serious injury or death if the engine is not shut off during maintenance procedures.

Shut off the engine and remove the key.

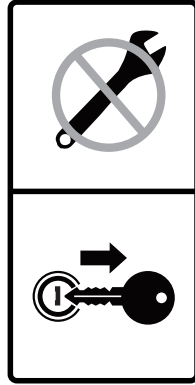

**IMPORTANT! If parts are replaced that have safety signs on them, new signs must be applied. Safety signs must always be replaced if they become damaged, are removed, or become illegible.**

Safety signs are included in the product decal kit available from your authorized dealer. Decals are not available separately.

### 2.17.1 Replacing Damaged Safety Signs

- Always keep safety signs clean and legible.
- Replace safety signs that are missing or have become illegible.
- Parts that were replaced with a safety decal on them must also have the safety sign replaced.
- Replacement safety signs are available from your authorized Distributor, Dealer Parts Department, or Wallenstein Equipment.

#### Procedure

1. Be sure that the installation area is clean and dry.
2. Be sure temperature is above 50 °F (10 °C).
3. Determine exact position before removing from the backing paper.
4. Pull the decal off the backing sheet, align the sign over the specified area, then carefully press the exposed sticky backing in place.
5. Use a piece of the backing paper to smooth the decal out, pressing from the center outwards.
6. Small air pockets can be pierced with a pin and smoothed out using the piece of sign backing paper.

## 3. Familiarization

### 3.1 To the New Operator or Owner

It is the responsibility of the owner or operator to read this manual and to train all other operators before they start working with the machine. Follow all safety instructions. Untrained operators are not qualified to use the machine.

1. Review control location, function and movement directions.
2. Move the unit to a large open area to allow the operator to become familiar with control function and machine response. When a new operator is familiar and comfortable with the machine, they can proceed with the work.
3. Do not allow untrained operators to use the machine. They can endanger themselves and others or damage property and the machine.

---

**IMPORTANT!** Make sure all operators understand how to put the machine in a safe service position before servicing or repairing. See *page 8*.

---

### 3.2 Job Site Familiarization

It is the responsibility of the operator to be thoroughly familiar with the work site prior to starting. Prevent the chance or possibility of problems or accidents by avoiding unsafe situations.

Some items operators should check include, but are not limited to:

1. Avoid close or cramped work spaces. Be sure there is enough space and clearance for the machine.
2. Position the machine so prevailing winds blow engine exhaust fumes and chain saw chips away from operator's station.
3. Choose flat and level ground and make sure the machine is level before operating.
4. Avoid muddy or soft ground as the jacks will sink in. If unavoidable, use boards or plates to increase the surface area of the jack feet.

### 3.3 Operator Orientation

---

**IMPORTANT!** When describing controls throughout this manual, the directions for left-hand, right-hand, backward and forward are determined when standing at the operator controls facing the direction of forward machine travel.

---

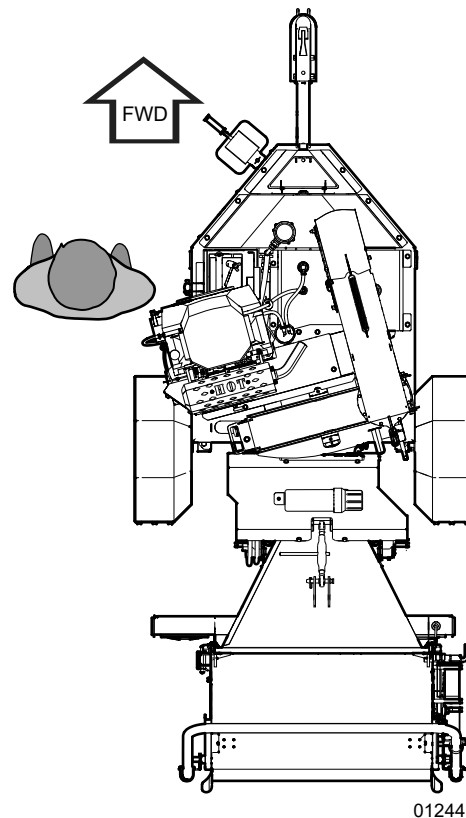

**Fig. 4**—Direction of Forward Machine Travel

### 3.3.1 Machine Components

1. Twig Breaker
2. Upper Rotor Housing
3. Rotor
4. Rotor Knife
5. Rotor Sheave
6. Honda GX690 Engine
7. Double-B V-belt
8. Battery
9. Tool Box
10. Crank Jack
11. 2" Coupler
12. Feed Rollers
13. Feed Roller Control Bar
14. Feed Hopper
15. Feed Table
16. Rear Foot Stand
17. Manual Tube
18. Tires / wheels 5.3-12 LRB
19. Hydraulic Pump
20. P3 PULSE Display
21. Wire Harness Plug – 4 Pin
22. Centrifugal Clutch
23. Discharge Chute
24. Hood Deflector
25. Ledger Blade
26. Fuel Tank
27. Hydraulic Tank

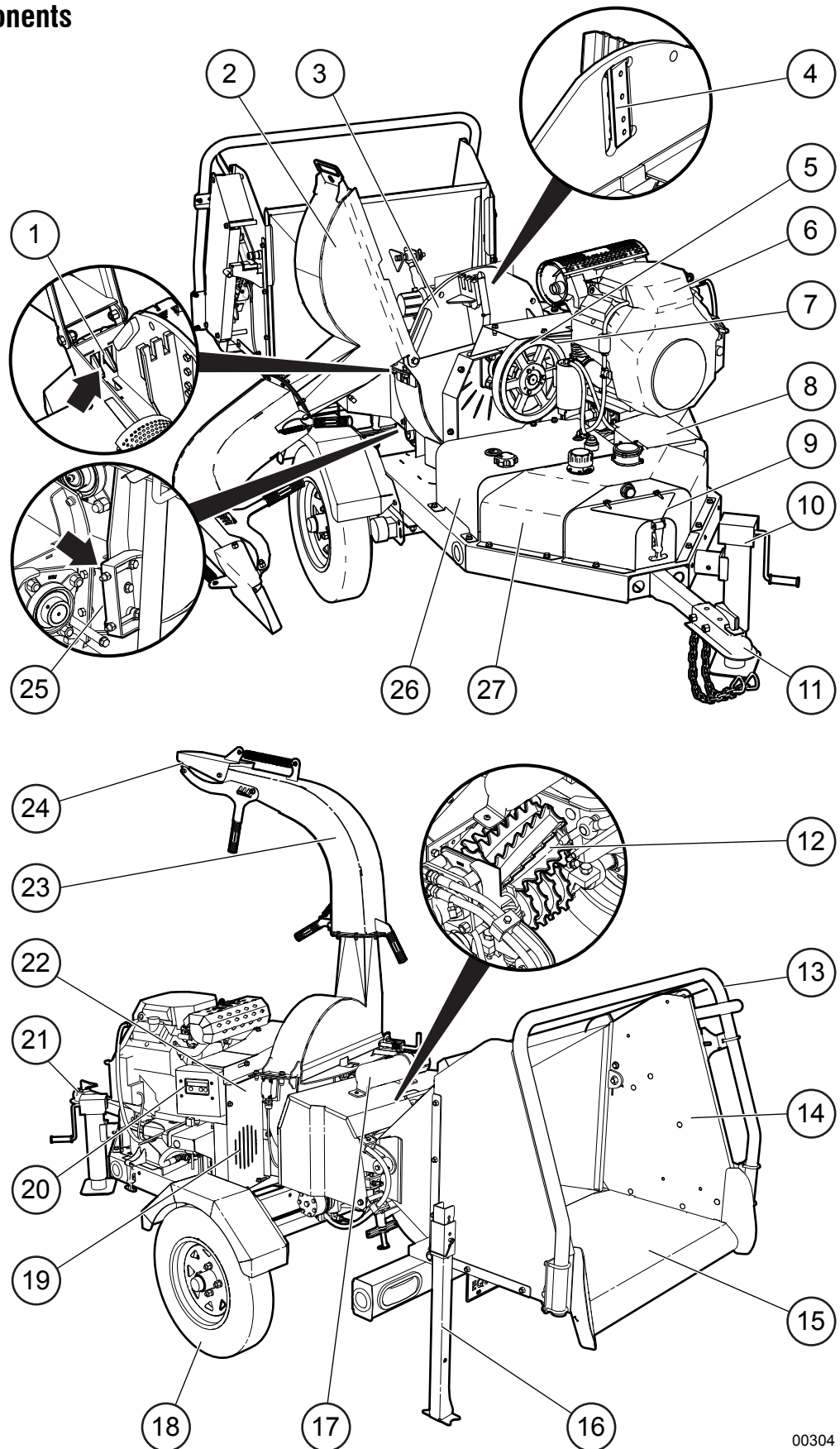

Fig. 5–Machine Components

00304

## 4. Controls

**IMPORTANT!** Before starting work with the chipper, become familiar with the location and function of all controls.

### 4.1 Engine Controls

Refer to the engine manual for further explanation on engine controls.

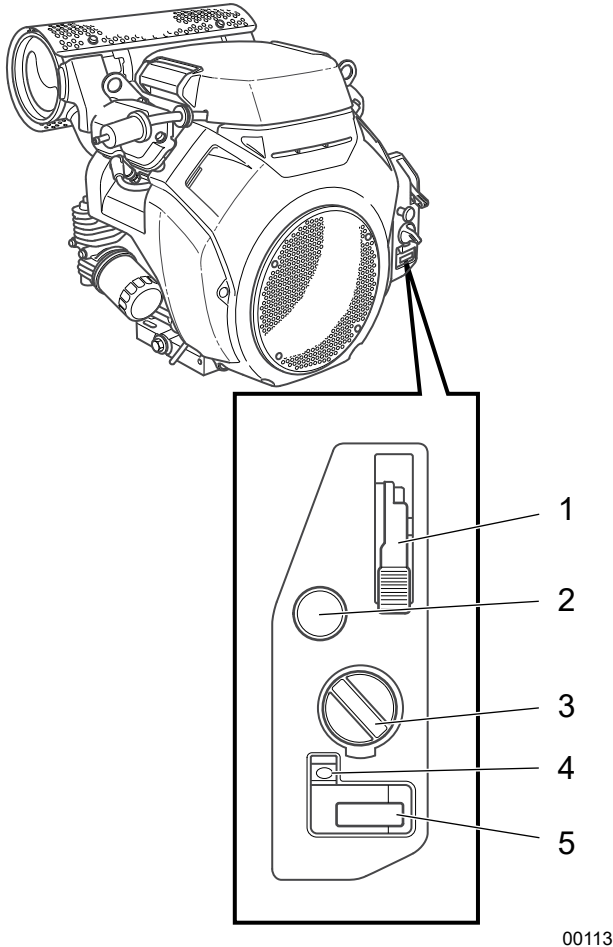

00113

**Fig. 6**—Engine Controls

1. Throttle Lever
2. Choke Knob
3. Engine Start Switch
4. Low Oil Level Alert Indicator
5. Engine Hour Meter

#### 4.1.1 Throttle Lever

The Throttle Lever controls engine speed. Warm up the engine before putting the chipper to work. The throttle lever should be at the MAX position during chipper operation.

- Pull the lever up to increase engine speed.
- Push the lever down to decrease engine speed.

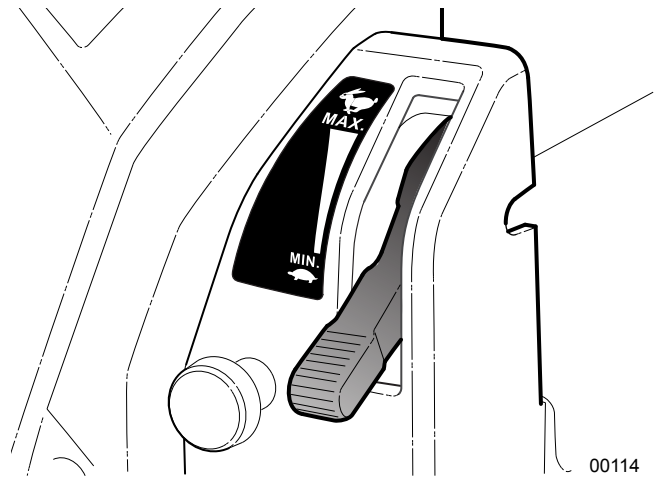

00114

**Fig. 7**—Throttle Lever

#### 4.1.2 Choke Knob

The Choke Knob is used as a starting aid when the engine is cold. Pulling the knob out supplies a richer fuel mixture to aid the engine in starting.

- Pull the knob out to apply (close) the choke when starting a cold engine.
- Push the knob in gradually to turn off (open) the choke as the engine warms.

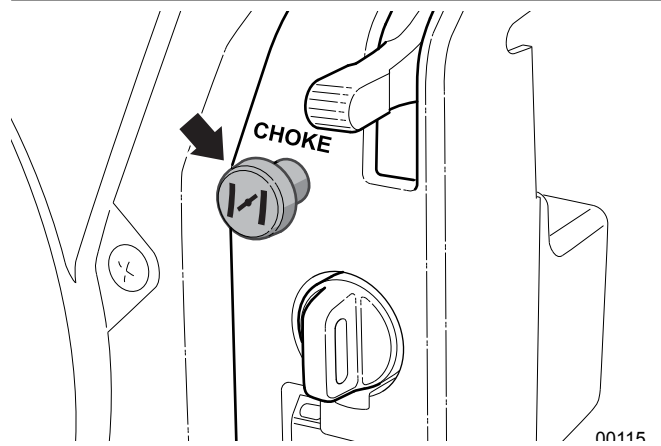

00115

**Fig. 8**—Choke Knob

### 4.1.3 Engine Start Switch

The Engine Start Switch has three positions—OFF, ON, and START.

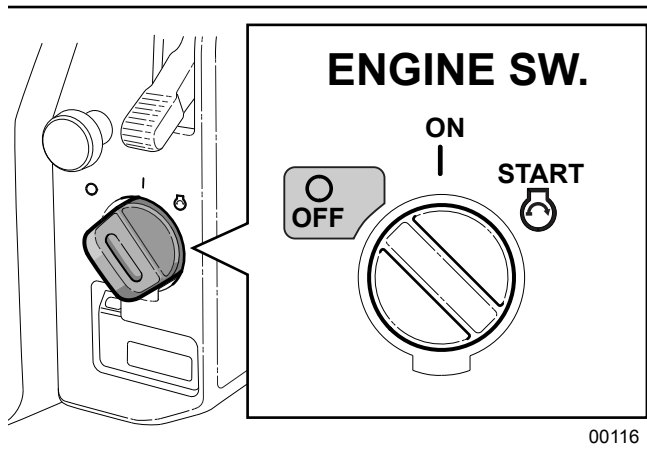

Fig. 9—Engine Start Switch

- **OFF** – In the OFF position, there is no power to the engine and fuel supply is turned off. Turn the switch fully counter-clockwise to shut the engine off.
- | **ON** – In the ON (run) position, the fuel supply solenoid supplies fuel to the engine. The machine operates in this position.
- Ⓚ **START** – In the START position, the engine electric starter is activated. When released, the switch spring-returns to ON.

### 4.1.4 Engine Hours and Oil Level Alert

Refer to the engine manual for further information.

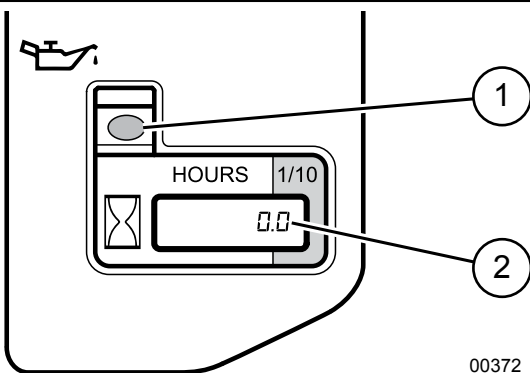

Fig. 10—Engine Hours and Oil Level Alert

1. Engine Oil Level Alert Indicator Light (Red)
2. Engine Operating Hours

### 4.2 Discharge Chute

The discharge chute can be rotated 360°. It has a spring-loaded latch that locks it in position.

1. Lift the latch handle up to disengage the lock pin.
2. Use grip handles and rotate the chute.
3. Release the handles and lock the chute into position at the nearest lock point.

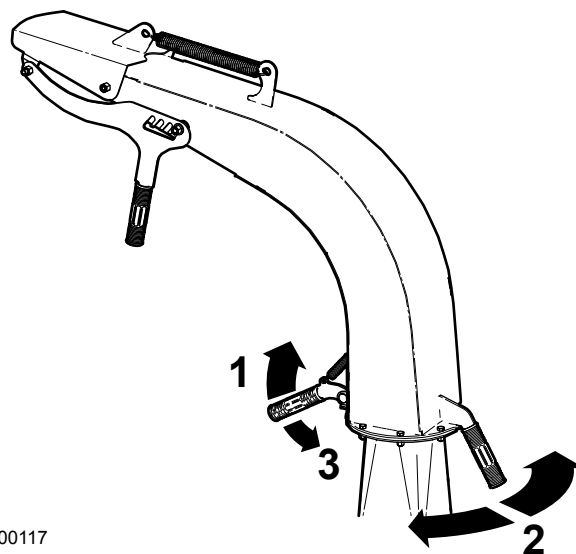

Fig. 11—Discharge Chute

### 4.3 Hood Deflector

The Hood Deflector is on the end of the discharge chute to direct the chip output. The deflector is held in position by a slotted position handle.

1. Grasp the handle and lift slightly to clear the handle cogs.
2. Move the deflector with the handle as required.
3. Lock the deflector into position by lowering the handle into one of the slots.

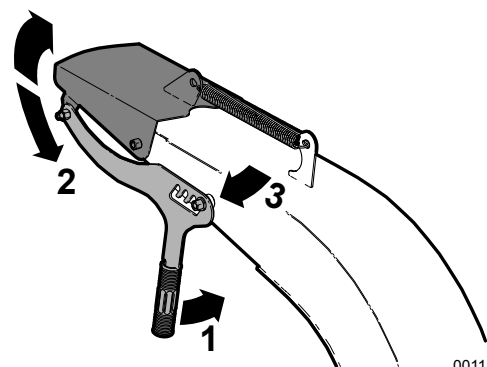

Fig. 12—Hood Deflector

## 4.4 Feed Roller Control Bar

### **WARNING!**

**Risk of serious injury or death. Keep hands, feet and clothing away from feed rollers when the chipper is operating. Do not climb onto the feed table or hopper.**

W023

The Feed Roller Control Bar on the back of the hopper controls the material feed into the chipper. The control bar has four positions—**Stop, Forward, Reverse, Stop**. Decals on the side of the feed table indicate feed control bar operation.

The control bar can be moved freely between Forward and Reverse. Once moved into either Stop position, the bar is locked there until the Detent Release Lever is pulled up to release it.

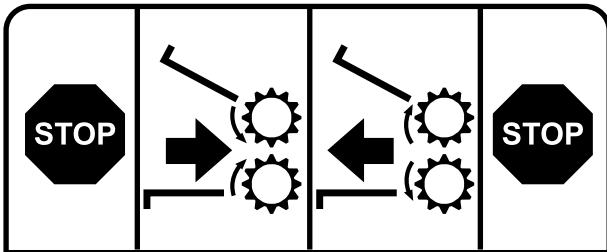

00125

Fig. 13—Feed Roller Control Bar Positions (RH side shown)

### 4.4.1 STOP Positions

Stop the feed rollers at any time by pushing the control bar fully forward or pulling it fully rearward.

- Push the control bar fully **forward** (towards the feed table) into the maximum detent position to stop the feed roller.

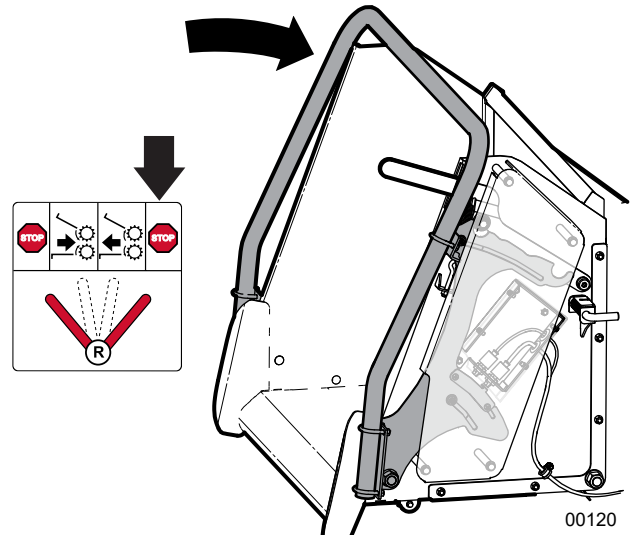

00120

Fig. 14—Forward STOP position

- Pull the feed roller control bar fully **rearward** (away from the feed table) to the maximum detent position to stop the feed rollers.

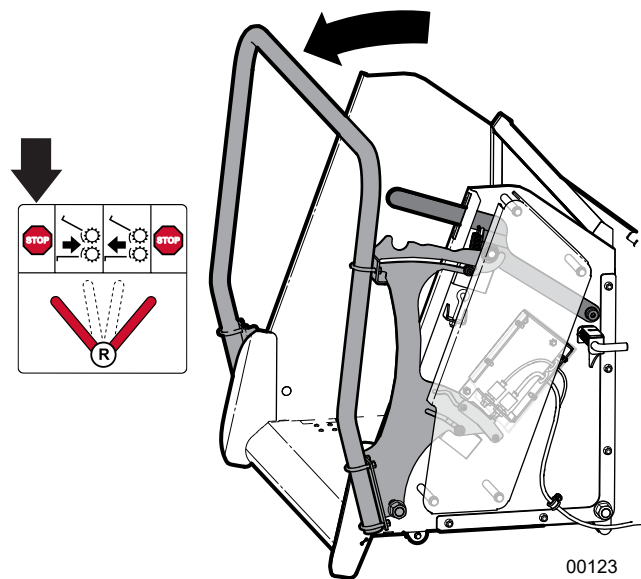

00123

Fig. 15—Rearward STOP position

- To move the control bar out of either Stop position, lift up the Detent Reset Lever to release it.

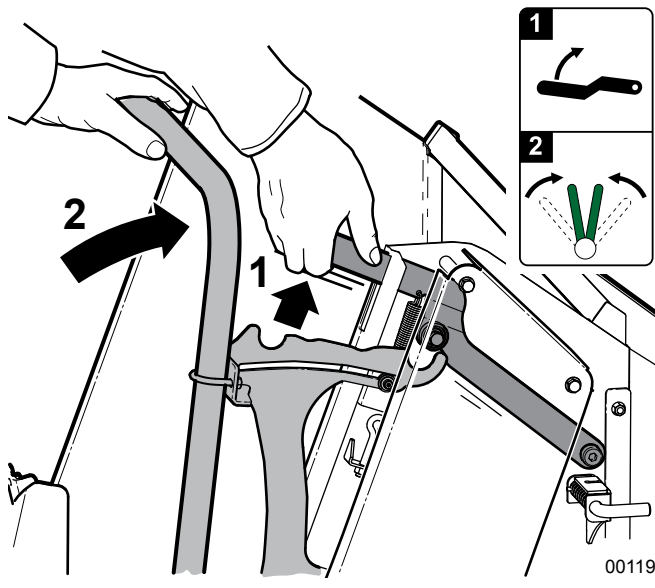

Fig. 16 – Detent Reset Lever

#### 4.4.2 Forward (Feed) – Position 2

- Lift up the detent reset lever, push the feed roller control bar forward to the first detent position to start the forward feed. This is the normal operating position. The control bar stays in this position until moved.

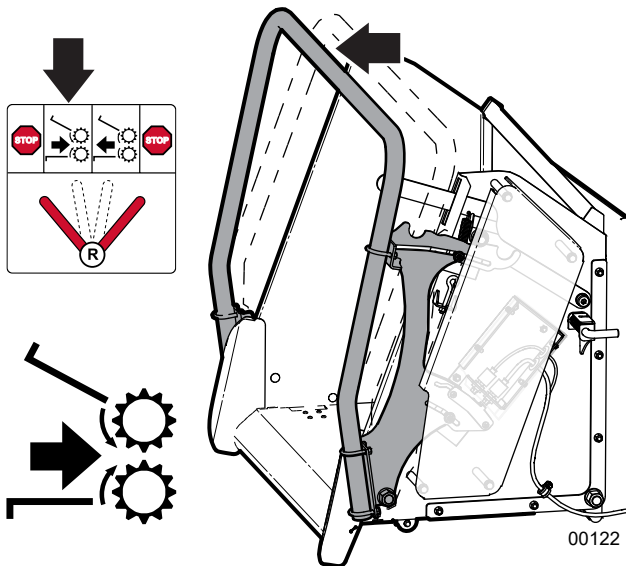

Fig. 17 – Feed – Position 2

#### 4.4.3 Reverse – Position 3

- Push the control bar forward to the next detent position to reverse the feed rollers.

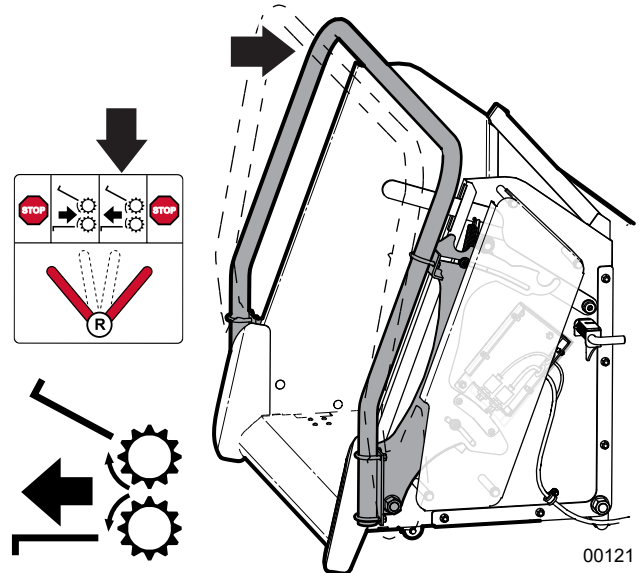

Fig. 18 – Reverse – Position 3

**NOTE:** The feed roller control bar can move freely between Forward and Reverse without locking.



## 4.5 P3 PULSE Electronic Control System

Software version 1.0.0

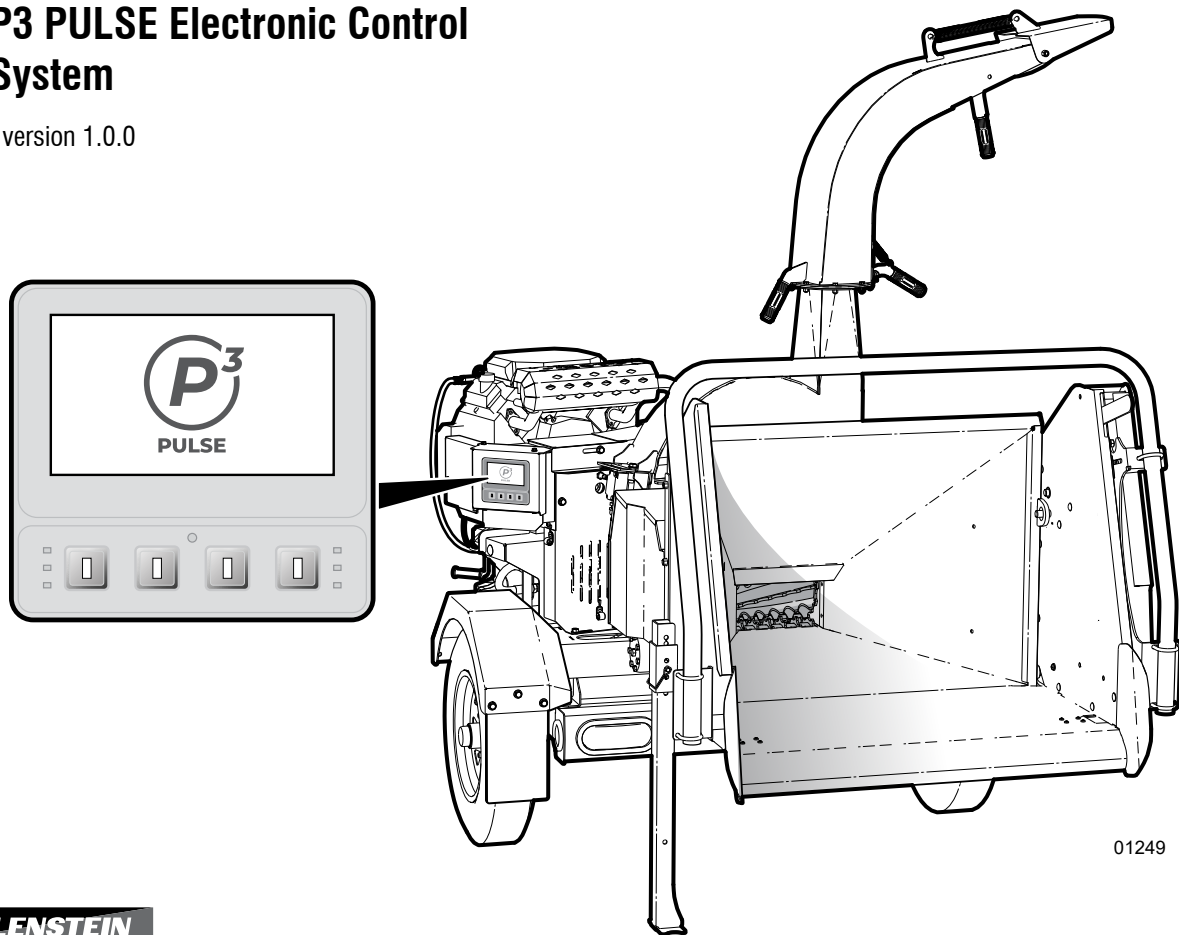

**WALLENSTEIN**

Fig. 19—Wallenstein P3 PULSE Electronic Control System

### 4.5.1 Overview

The Wallenstein P3 PULSE Electronic Control System optimizes the capacity of the chipper. Operators can adjust feed settings to customize chip size when chipping any type of material. P3 tracks rotor hours of operation and provides system diagnostics. In the unlikely event the rotor becomes jammed with material, P3 quickly stops the engine to prevent clutch burn out.

P3 keeps the chipper working in the peak working range by matching feed rate with rotor speed. As material is put into the chipper, a sensor on the rotor sheave continually monitors rotor rpm. If the rotor slows down under load, P3 slows the feed roller speed allowing the rotor to recover. If it slows below the minimum rotor speed setting, P3 auto-reverses the feed rollers preventing a stall out. Wood material is then pulled away from the rotor giving it the opportunity to regain speed. Once back at operating rpm, the feed rollers start feeding material into the chipper again.

P3 PULSE consists of a rugged, user-friendly 4.3" (109 mm) display and electronic controller. From the display, the user can see all the important operating parameters. These parameters are set up depending on machine model.

Navigating through the menus is done with the four soft keys below the display screen. Icons in the display above the soft keys indicate menu selection options.

**IMPORTANT! Graphical display and controller are not serviceable. Return to the factory in the event of failure.**

### 4.5.2 Start-up Screen

The start-up screen displays briefly with P3 PULSE™ logo when the key is turned ON.



01247







### 4.5.3 User Interface

#### 1. Display Screen

The Display Screen is the user interface for the P3 PULSE Electronic Control System. The screen is an anti-glare coated, 4.3 in (109 mm) color display. The system is controlled by navigating through the soft key buttons.

#### 2. Soft Key Indicator Icons

These icons are displayed directly above the Soft Key Navigation Buttons. They indicate your current selection options and are only shown when that selection is available.

-  Settings
-  Home
-  Up Arrow
-  Down Arrow
-  Select a value (enter)
-  Cancel

#### 3. Navigation Soft Keys

Navigate through information and configuration screens using the four context-dependent soft keys located on the front of the display.

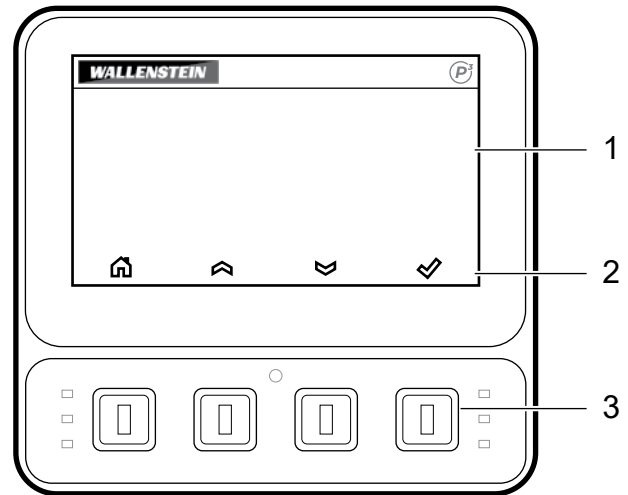
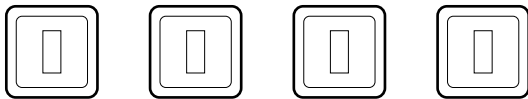



Fig. 20 – P3 Display Front Panel

01237

## 4.5.4 Menus

### Main screen

The **Main** screen is the default screen with the ignition key in the ON position. Pressing the key below  *Home* icon in any sub menu takes you back to the Main screen.

If the display is left unattended for a period (approximately 60 seconds), the system returns to the Main screen.

The **Main** screen displays:

- Feed Position (feed roller rotation direction)
- Rotor Speed (rpm)
- Hours (rotor hours of operation)
- Settings Icon

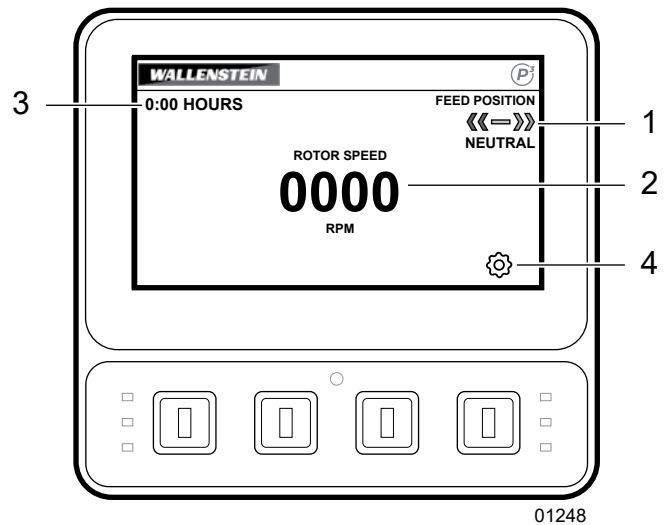





Fig. 21 – Main Screen

#### 1. Feed Position

Feed roller drive position is displayed with colored icons to indicate direction.

 **REVERSE** REVERSE (red arrows) – feed rollers are reversing. Material in the rollers is being pulled back away from the rotor.

 **NEUTRAL** NEUTRAL (amber) – feed rollers are stopped.

 **FORWARD** FORWARD (green arrows) – feed rollers are going forward. Material in the rollers is pushed into the rotor.

 **LOW RPM** LOW RPM (green arrows) – with the feed control bar in Forward, feed rollers are not moving because rotor RPM is too low for chipping. Once engine speed is increased above the minimum start speed, FORWARD is displayed.

#### 2. Rotor Speed (rpm)

Displays the speed (revolutions per minute) the rotor is turning. A value of 0000 indicates the rotor is not turning.

#### 3. Hours

Counts the total operating hours of the rotor. This value is not resettable. (Engine hours are displayed on the hour meter beside the ignition key. Use Engine Hours as a service interval guide.)

#### 4. Settings



Press the soft key button below  *Settings* icon to navigate to the **Settings** screen.

## Settings screen

Press the soft key button below the  icon to access **Settings**. This is the main screen to set up all your machine parameters. All settings are retained when the machine is shut down.

The **Settings** screen menu contains:

- Feed Settings – Set the maximum and minimum feed roller speed settings, feed roller start rpm, minimum feed roller speed.
- Reset Defaults – Returns all settings to the factory default values.
- Diagnostics – Provides an overview of operating parameters, rotor speed, solenoid valve current, feed roller position. Used for debugging and testing purposes.
- Select Machine – Chose machine model to set the default operating parameters for your machine.
- Enter Password – This password protected menu provides access to factory settings.

Use the Up  and Down  arrows to cycle through the menus. The active selection is highlighted.

Press the soft key below  icon to select that menu.

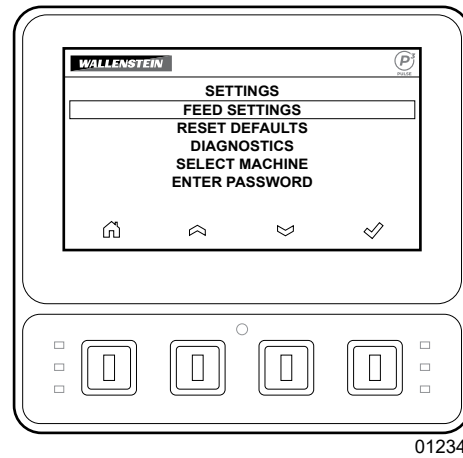
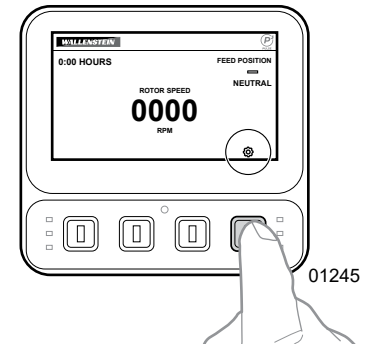







Fig. 22—Settings Screen

## Feed Settings screen

**Feed Settings** screen provides access to the four main P3 PULSE program settings.

The active selection is highlighted. Pressing  advances to the next setting. **Max Feed Speed** is the first menu accessed.

- To make adjustments within any menu, press  to advance to that menu, then use Up  and Down  arrows to make any changes.
- Pressing  saves your new setting and advances to the next menu to the right. Press  as required to exit back to **Settings** screen.

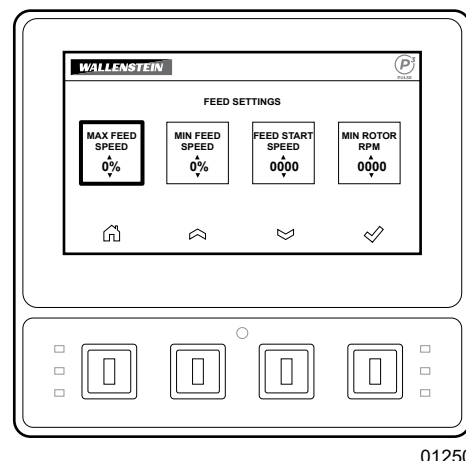
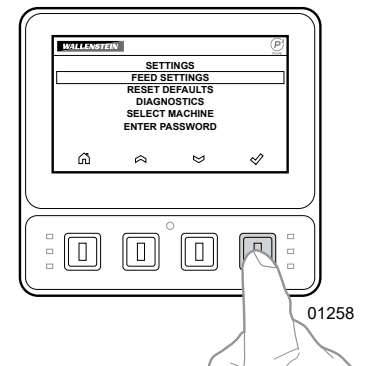
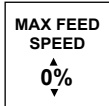

Fig. 23—Feed Settings Screen

### Max Feed Speed



Sets the maximum feed roller speed in 5% increments. The value is shown as a percentage of the maximum speed (100%).

- Set **Max Feed Speed** higher for larger chip size. It can be set and left at 100%.
- Set it lower close to **Min Feed Speed** for smaller consistent chip size.

### Min Feed Speed

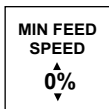

Sets the minimum feed roller speed in 5% increments. The value is shown as a percentage of the maximum speed (100%). Setting **Min Feed Speed** higher allows larger chip size and prevents the chipper from slowing up as much when wood is put through.

*(Min Feed Setting cannot be set any higher than 5% below Max Feed Setting.)*

### Feed Start Speed

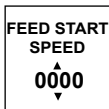

Sets the rpm point where feed rollers start up.

### Min Rotor rpm

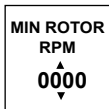

Sets the low rpm point where the feed rollers auto-reverse. If the rotor speed slows down under load below this setting, P3 auto-reverses the feed rollers. Once the rotor regains speed, Forward feed resumes. If the engine stalls out, the **Minimum Rotor rpm** is set too low.

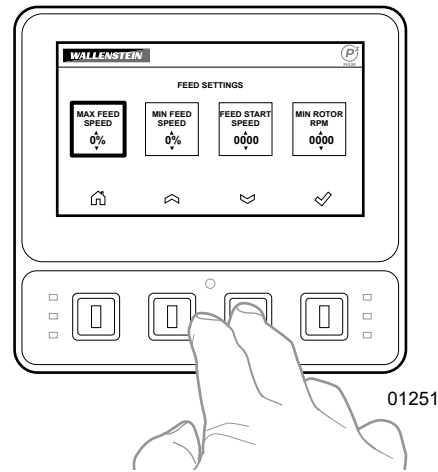







### Programming Hints

The factory settings provide good overall performance for the machine selected; however, you may choose to customize performance. Here are some helpful hints:

- For very heavy brush – decrease **Max Feed Speed** to slow feed roller speed.
- To get smaller, consistent chip size – decrease **Max Feed Speed** closer to **Min Feed Speed**.
- Larger chip sizes and more aggressive feeding – Leave **Max Feed Speed** at 100% and raise **Min Feed Speed**.

## Reset Defaults screen

P3 PULSE setup parameters can be returned to the factory settings if desired.

- From the **Settings** screen, use the Up  or Down  arrows to navigate to **Reset Defaults**.
- Pres  to reset all P3 settings back to factory default values.
- The next screen asks you to confirm the reset. Press the key below  to reject and  to accept.
- If you press  to cancel, the menu returns back to the **Settings** screen without changing your setup.
- If you press  to accept, P3 reboots and resets all settings to factory default values.

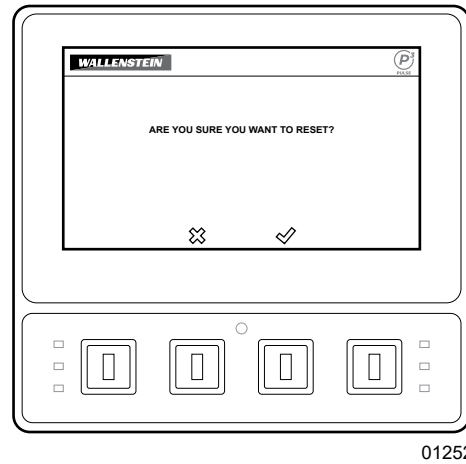
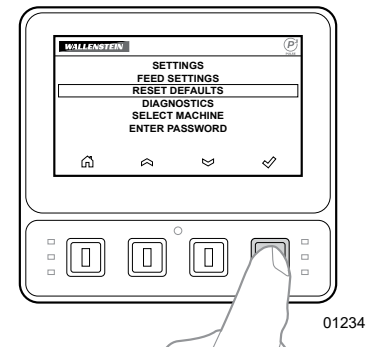

Fig. 24 – Reset Defaults Screen

## Diagnostics screen

The **Diagnostics** screen displays default settings, feed roller direction, and electrical current supplied to the Forward solenoid on the control valve.

**Diagnostics** is typically used for debugging and testing purposes by technicians. During operation, observe all machine settings from this screen.

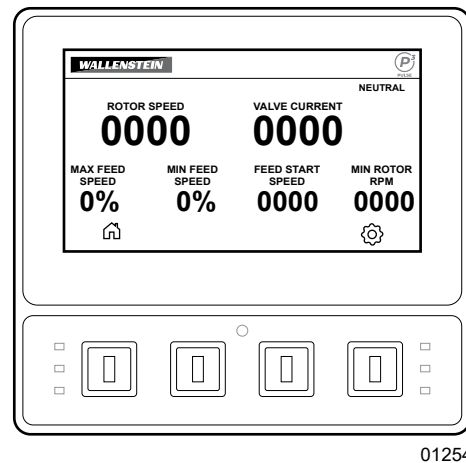
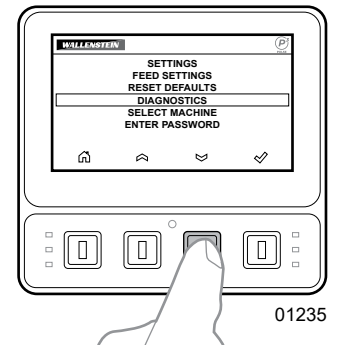









Fig. 25 – Diagnostics Screen

## Machine Select screen

**IMPORTANT!** Machine model must be selected during initial setup before operating the machine.

**Machine Select** must be done when the P3 PULSE is set up for the first time. Once you have selected your machine, P3 sets up the default settings for that model.

- From the **Settings** screen, use the Up  or Down  arrows to navigate to **Select Machine**, then press .
- Press the Up  or Down  arrows to find your machine model.
- Press  to save your selection and P3 returns to **Settings** menu.
- Pressing  Home icon exits to the **Settings** screen without saving your selection or changing any settings.

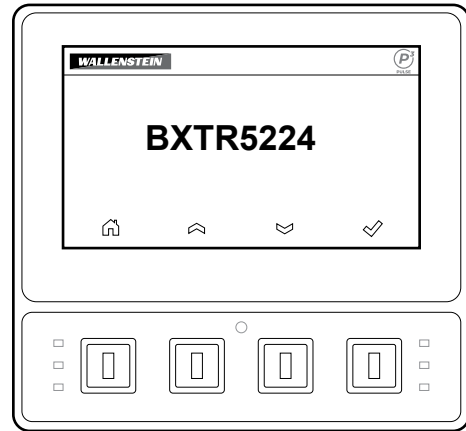
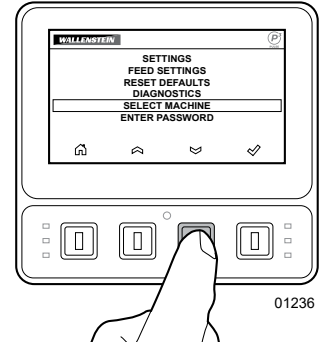
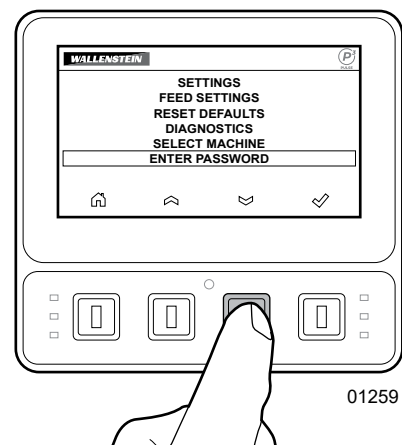

Fig. 26–Select Machine Screen

## Enter Password

This password protected menu provides access to P3 program settings. This menu is only used by the factory for initial P3 machine setup parameters.



## 4.6 Ladder Hitch Kit

### (If equipped)

The Ladder Hitch provides an adjustable hitch height for the tow vehicle.

The 2" ball coupler has three height positions and includes two, 3 ft (1 m) 1/4" safety chains with snaps.

- Lower the coupler down onto the hitch ball. Make sure the ball clamp is under it.
- Hand-tighten the coupler by pushing down on it and turning the hand wheel clockwise.
- Turn the hand wheel until the coupler is tight. Make sure the hitch ball is properly seated by pushing back on the chipper. Recheck that the hand wheel is tight.
- Check all connections at each stop. Make sure the hitch and hitch-ball are securely attached to your tow vehicle and that the trailer coupler is properly connected to the hitch-ball.

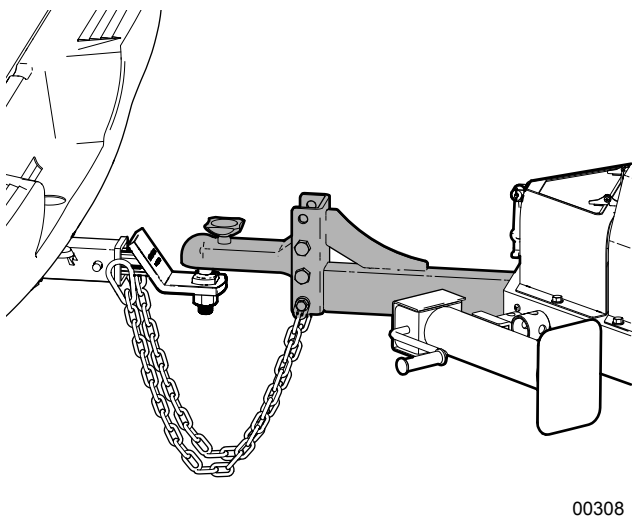

Fig. 27—Ladder Hitch Option

## 4.7 Clean-out Tray

### (If equipped)

The Clean-out Tray is available as an add-on accessory for the chipper. It catches fine debris under the feed rollers and prevents it from falling out onto the ground.

With the tray closed, debris is caught inside the roller housing saving clean-up underneath the chipper.

Empty debris out of the roller housing by pushing the Clean-out Tray lever forward.

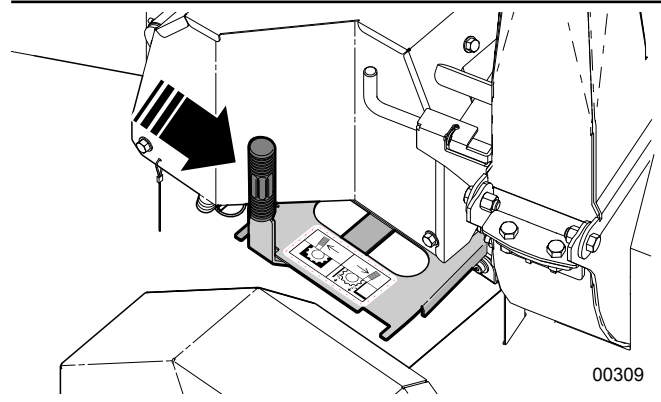

Fig. 28—Clean-out Tray Lever

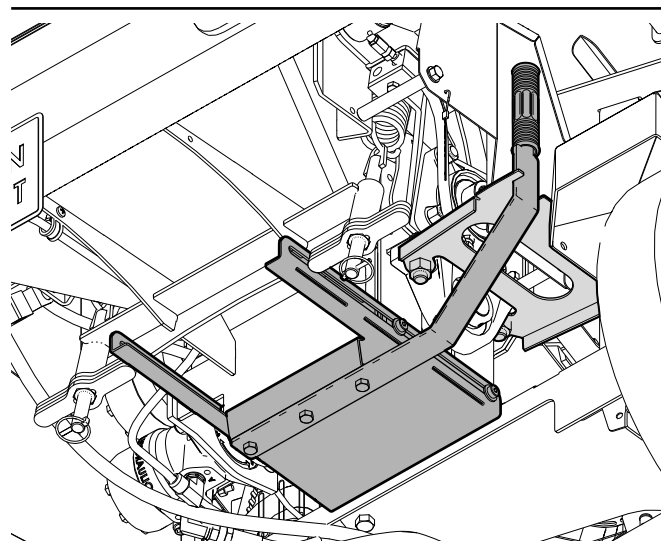

Fig. 29—View of Clean-out Tray from Underside of Chipper



## 5. Operating Instructions

### CAUTION!



**Hearing loss hazard. Prolonged exposure to loud noise may cause permanent hearing loss. Use suitable protection while operating the machine.**

W016

**The operator has the responsibility of being familiar with and following all operating and safety procedures.**

**When operating this equipment always have at least two workers present and trained in safe operation of the machine.**

**Although this machine is easy to use, each operator should review this section to get familiar with the detailed safety and operating procedures.**

### 5.1 Before Startup

1. Check the engine oil level. See *page 35*.
2. Check the hydraulic oil level. See *page 35*.
3. Open the fuel valve. Check the fuel level. See *page 36*.
4. Check the engine air cleaner. See *page 49*.
5. Review the Safety Rules on *page 8*.
6. Clear the area of bystanders, especially small children.
7. Make sure each operator is trained and familiar with the set up and operation of the wood chipper.
8. Perform the Pre-operation Checks.
9. Review the Controls (see *page 21*).
10. Survey the work site and place the chipper in a clear, level work area.
11. Set up the machine correctly. See Machine Setup *page 36*.

### 5.2 Pre-operation Checks

Check the following each time the wood chipper is used:

Area to Check	✓
Check the machine has been lubricated following the schedule outlined in the Maintenance section.	
Check the tension and alignment of the belts. Adjust as required.	
Check the rotor housing and discharge chute. Remove any blockages, twine, wire or other material that has become entangled.	
Check the condition and clearance of the twig breaker, rotor and stationary blades. Adjust or replace as required.	
Check condition of the battery and other electrical components. Keep all components in good condition.	
Check for hydraulic leaks. Tighten connections or replace components to stop leaks.	
Check and ensure that all covers, guards and shields are in place, secured, and can function as designed.	
Check that all bearings are properly greased. Replace if they do not turn freely.	
Check and inspect tires, wheels, and hubs.	
Check hydraulic fluid level. Top level up as required.	
Check and tighten all fasteners. Make sure the equipment is in good condition.	

## 5.3 Machine Break-In

Although there are no operational restrictions on the wood chipper when used for the first time, it is recommended that the following mechanical items be checked:

### After 1–5 hours of operation:

1. Review the engine operator's manual for break-in information.
2. Inspect the axle, tires, and wheel hubs. Check wheel nut torque.
3. Check tire pressure. Inflate as required.
4. Check sheave alignment. Re-align if required. See *page 52*.
5. Check belt tension. Adjust if required. See *page 51 and page 52*.
6. Visually check condition of rotor bearings.
7. Check the condition and clearance of the twig-breaker, rotor and ledger blades. Adjust as required.
8. Check for entangled material. Remove all entangled material before resuming work.
9. Check condition of electrical and hydraulic components. Keep all components in good condition.
10. Check all fluid levels. Top up as required.
11. Check torque on fasteners and hardware.

### After 8 hours of operation:

12. Repeat all previous steps.
13. Check wheel bolt torque after 20–25 mi (32–40 km). Regularly check weekly.
14. Perform all the checks in the Pre-operation Checks. See *page 33*.

## 5.4 Fuel Level Check

**Check the fuel level daily.** Starting with a full tank helps to eliminate or reduce operating interruptions for refueling.

The fuel tank is located on the front right-hand side of the machine. Avoid running the tank dry.

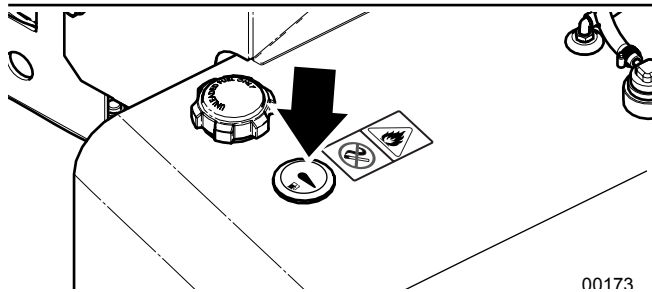

Fig. 30—Fuel Level Gauge

### 5.4.1 Refueling

Fuel tank capacity: **6.5 US gal (24.6 L)**.

#### **WARNING!**



**Fuel vapors can explode causing injury or death. Do not smoke while refueling. Keep sparks, flames, and hot components away.**

W027

Refuel in a well-ventilated area with the engine stopped. If the engine has been running, allow it to cool first. Never refuel the engine inside a building where gasoline fumes can come in contact with flames or sparks.

For fuel specification, see *Engine Fuel on page 43*. Refer to the engine manual for additional information on fuels.

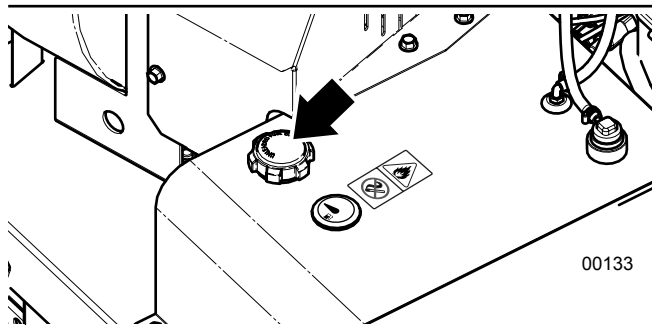

Fig. 31—Fuel tank Cap

1. Clean the area around fuel tank cap. Fill the tank to 1/2" (12 mm) below bottom of filler neck to provide space for any fuel expansion. **Do not overfill.**
2. Install fuel fill cap securely and wipe up any spilled fuel.

## 5.5 Engine Oil Level Check

**Check engine oil level daily.** Check with the machine parked on level ground and the engine stopped.

**IMPORTANT! Running the engine with a low oil level can cause engine damage that is not covered by warranty.**

1. Remove the oil level dipstick and wipe it clean.
2. Fully insert the oil level dipstick, then remove it to check the oil level.
3. If the oil level is low, remove the oil filler cap and add oil until the level is at the FULL mark on the oil level dipstick.  
**SAE 10W-30 or 5W-30 is recommended for general use.**
4. Reinstall the oil level dipstick and oil filler cap.

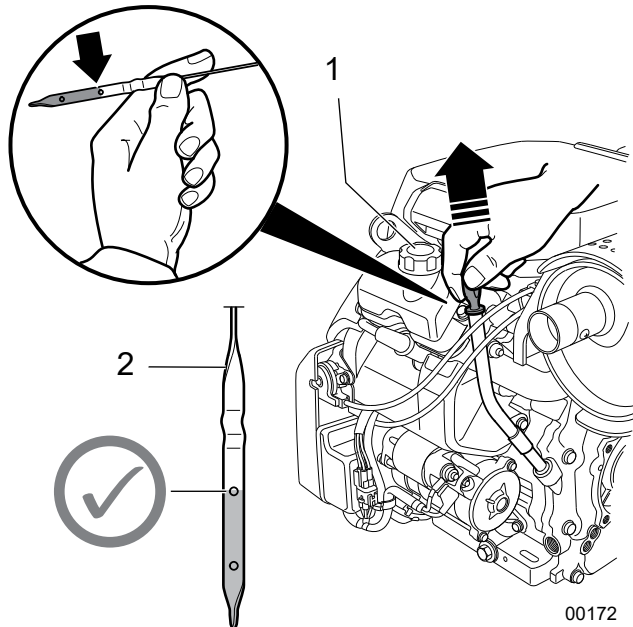

**Fig. 32**—Checking Engine Oil Level

1. Oil Filler Cap
2. Oil Level Dipstick

Refer to the engine owner's manual included in the manual tube for further information on engine oils.

## 5.6 Hydraulic Oil Level Check

**Check hydraulic oil level daily.** The hydraulic oil tank is located on the front of the machine. There is a sight glass on the tank to view oil level.

Check with the machine parked on level ground and the engine stopped.

**The proper level is when the oil is visible in half the glass window.** If the level is not visible in the sight glass, add oil.

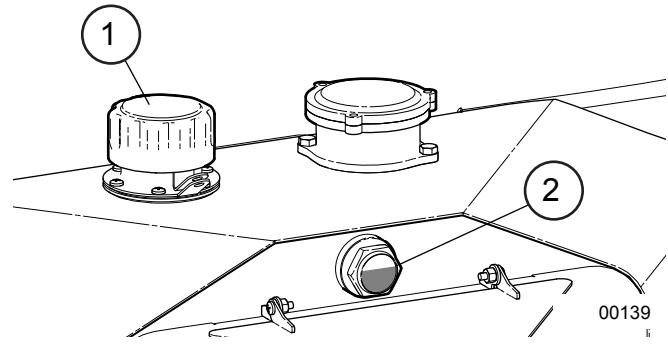

**Fig. 33**—Hydraulic Tank Oil Level Check

1. Hydraulic Tank Filler Cap
2. Oil Level Sight Glass

**IMPORTANT! Do not operate machine if oil level is not visible in the sight glass. Damage to the pump and other components can occur.**

**Do not overfill the tank past the sight glass window.**

**IMPORTANT! Hydraulic oil quality should be inspected every 50 hours. If the oil is dirty or smells burnt, it should be replaced.**

**IMPORTANT! Be aware of high oil temperatures. Temperatures higher than 180 °F (82 °C) could cause seal damage and degrade oil quality.**

### 5.6.1 Adding Oil to the Tank

The hydraulic system uses **Dexron® III ATF**.

1. Clean the area around filler cap and remove it.
2. Use a clean funnel and add oil until the level fills half of the sight glass window.
3. Install filler cap securely. Wipe up any spilled oil.

Check levels after changing filters or servicing hydraulic components.

## 5.7 Machine Setup

### **! CAUTION!**

Park the machine so prevailing winds blow exhaust gases / fumes away from the operator.

W006

### **! CAUTION!**

Risk of injury from ejected wood chips. Chipper rotor can expel wood chips fast enough to cause injury or damage.

Direct chute discharge away from work area, people, animals, and objects.

W024

1. Use the tow vehicle to position the wood chipper at the work site. Leave the chipper attached to the tow vehicle (if used) for greater stability. Lower the rear jack.
2. With no tow vehicle available, chock the wheels and lower the jacks so that the machine is stable.

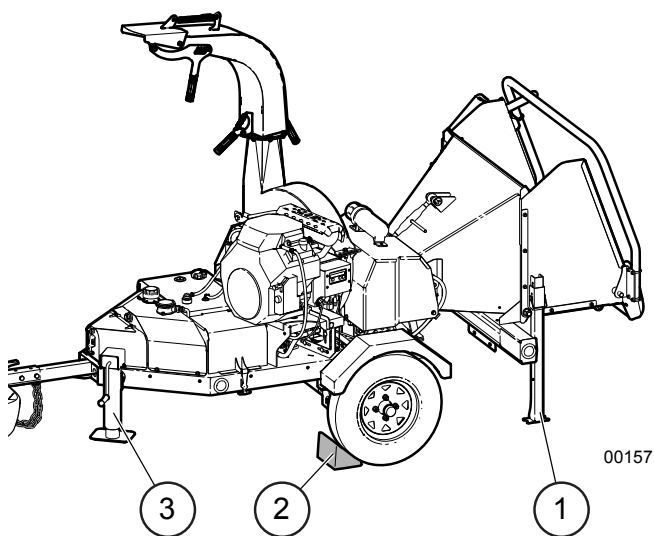

00157

**Fig. 34—Machine Setup**

1. Rear Jack Stand
2. Wheel Chocks
3. Crank Jack

3. On the rear of the feed table, pull the latches inward and lower it.

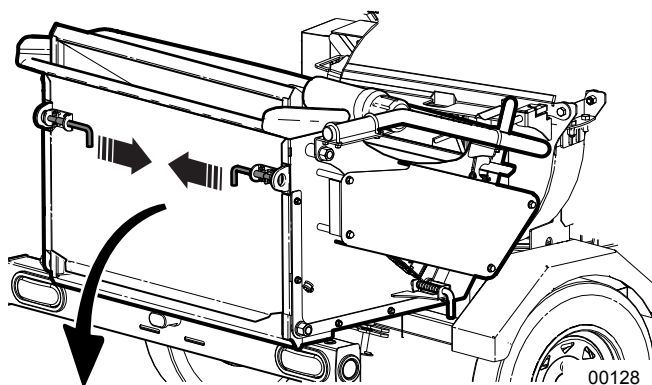

00128

**Fig. 35—Feed Table Latches**

4. On the right-hand side, lock the feed table in the lowered position.

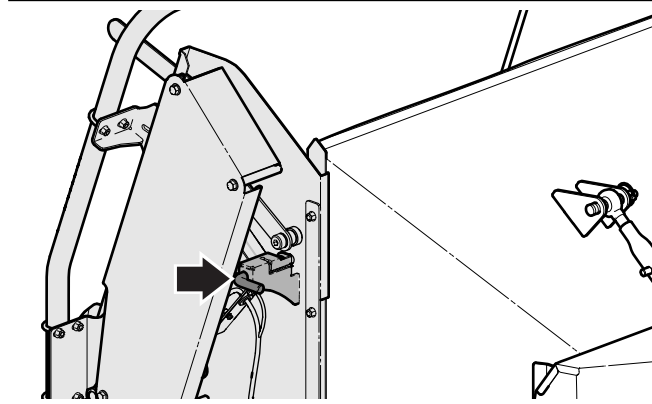

**Fig. 36—Feed Table Lowered**

5. Point the discharge chute in the desired direction. Adjust the hood deflector as required.

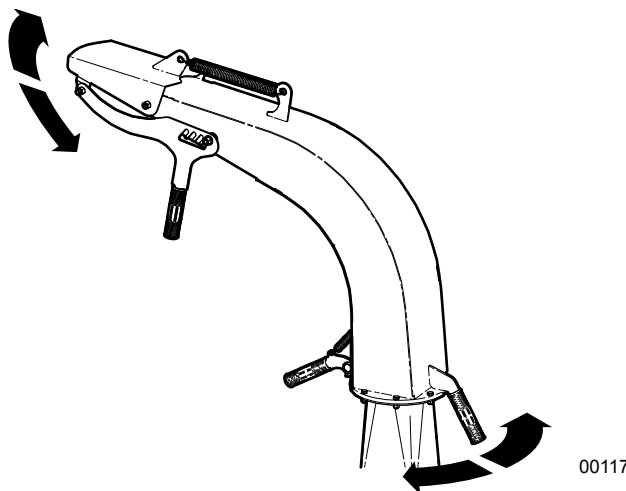

00117

**Fig. 37—Discharge Chute**

## 5.8 Starting the Engine

### **WARNING!**

Engine exhaust contains carbon monoxide, an odorless, poisonous gas. Breathing it can cause unconsciousness or death.

Never operate engine in a closed, or even partly closed area. Exhaust gases can build up to dangerous levels.

W072

 **NOTE:** For more detailed instructions, refer to the engine manufacturer owner's manual found in the manual tube.

Before starting the engine, the wood chipper should be checked over, set up to work and ready to run.

1. If the engine is cold, pull out (close) the choke. To start a warm engine, leave the choke pushed in.
2. Move the throttle lever up to 1/4 throttle position.

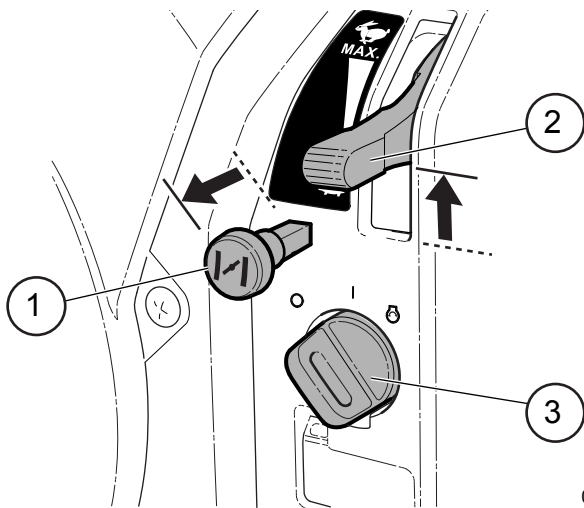

00130

**Fig. 38** – Starting the Engine

1. Choke Control Knob
2. Throttle Control Lever
3. Ignition Switch

3. Turn the ignition key switch fully clockwise to engage the starter. Release the key when the engine starts.
4. Leave the engine operating at low throttle for a few minutes to allow it to warm up. Gradually push the choke control knob in as the engine warms.

**IMPORTANT!** Allow the engine to warm up before moving throttle lever to MAX.

5. Once the engine is warmed, push the throttle lever up to **MAX** before starting chipping operation.

 **NOTE:** Throttle must be at MAX position to begin chipping operation. When not at MAX, P3 displays LOW RPM when in Forward feed.

## 5.9 Stopping Procedure

1. Stop feeding material into the hopper. Allow the machine to run for a few minutes so the chipper clears itself.
2. Decrease engine speed to **MIN**.
3. Turn the ignition key switch fully counter-clockwise to turn the engine off.

### **CAUTION!**

**Risk of injury from rotating parts. Wait for all parts to stop moving before attempting to access the machine. Rotor continues to turn for a few minutes after the engine has stopped.**

W025

## 5.10 Stopping in an Emergency

### In an emergency

- Turn the ignition switch to the OFF position.
- Correct fault situation before restarting engine and resuming work.

## 5.11 Chipping Operation

The Wallenstein wood chipper is a strong, rugged machine that is built to provide consistent chipping of logs up to 5" (13 cm) in diameter.

### **! WARNING!**

**Risk of serious injury or death. Keep hands, feet and clothing away from feed rollers when the chipper is operating. Do not climb onto the feed table or hopper.**

W023

### **! WARNING!**

**Never reach into the feed hopper. Doing so risks hands getting caught. Use a stick or branch to push in any material that does not move on its own.**

**If jammed, stop the engine, wait for the rotor to stop, then clear the jam.**

W004

**IMPORTANT!** Do not put metal objects, bottles, cans, rocks, glass or other foreign material into wood chipper. If such items happen to get into the chipper, stop machine and turn engine off. Wait for all moving parts to stop before removing material. Inspect machine for damaged or loose parts before resuming work.

- De-limb large branches and trees. The limbs on large branches sticking out of the feed hopper may catch the roller feed control bar, and shut the rollers off.
- Be aware of the size and shape of the material. Complicated, curved branches and logs can move in unpredictable ways as they pass through the feed rollers. Large curved pieces should be cut to smaller straighter sections.
- Hold small diameter branches together in a bundle and feed in together.
- Place short branches on top of longer ones to avoid reaching into the hopper.

## P3 PULSE

- P3 control system prevents the engine from getting bogged down if material is put into the chipper too quickly. Feed roller speed is regulated by monitoring the rotor rpm. For information on setup, see *P3 PULSE Electronic Control System on page 25*.

## Procedure:

1. Check the engine is warmed, at MAX throttle setting, and the rotor is up to speed. Once the rotor is up to speed, P3 PULSE starts the feed rollers when the feed roller control bar is placed in the Forward (feed) position.



**NOTE:** Engine throttle must be at MAX and rotor at full speed for feed rollers to function in Forward. Feed rollers function in Reverse even at engine idle so material can be backed out.

2. Move the feed roller control bar out of the Stop position. Lift up the detent reset lever to release it.

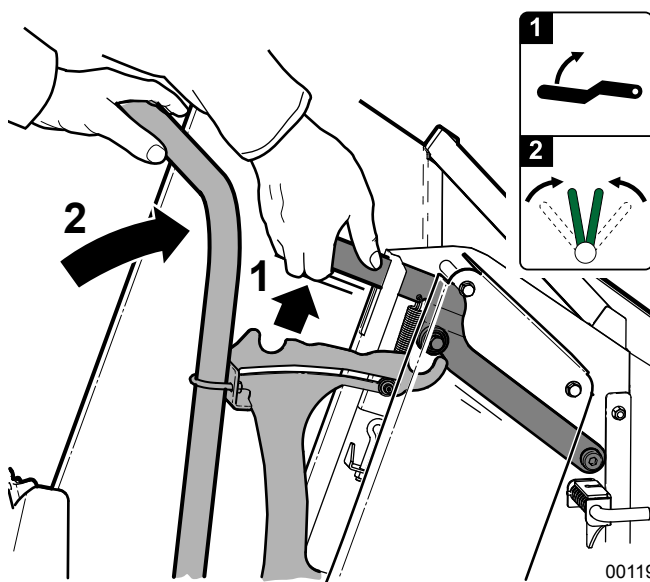

00119

**Fig. 39**—Detent Reset Lever

3. Push the control bar forward to the first detent position to start the Forward feed. The control bar stays in this position until moved.



**NOTE:** The control bar can move freely between Forward and Reverse without locking. Reversing the feed rollers can be manually controlled with the feed control handle at any time, even at engine idle. The rotor does not have to be turning for Reverse to work.

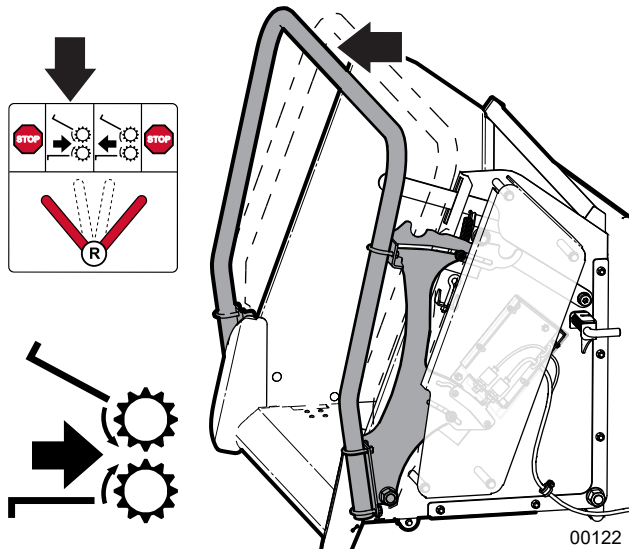

Fig. 40 – Forward Feed Position

- Stand to the side of the feed table and slowly slide material into the feed rollers. Do not force the material. The material is drawn in as it engages the rollers. **When operating this equipment always have at least two workers present and trained in safe operation of the machine.**

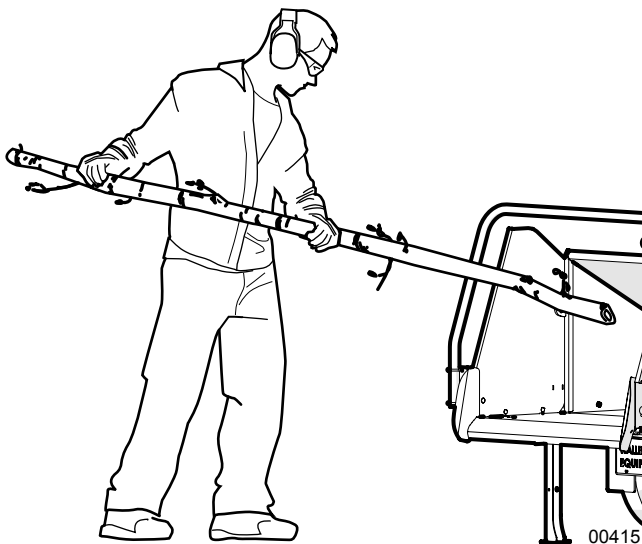

Fig. 41 – Stand to Side of Feed Table

- As material is put into the chipper, P3 continually monitors rotor speed. If the rotor slows down under load below a lower speed setting, P3 auto-reverses the feed rollers. Wood is then pulled away from the rotor giving it the opportunity to regain speed.
- Once back at operating rpm, P3 automatically resumes forward feed.

- Ensure your wood chip pile is contained and does not disturb the immediate work area.

## 5.12 Unplugging the Chipper

The wood chipper is designed to handle a wide range of material sizes without any problem. However, in the event material gets lodged in the chipper, follow this procedure to clear the blockage.

- Before shutting the engine off, reverse the feed rollers to remove the material from the feed hopper.
- Place the machine in a Safe Condition before proceeding further.** See page 8.
- Clear all the material out of the feed hopper. Make sure nothing is jammed or wedged between the feed rollers and the rotor. If material is jammed in this area, proceed to Step 7.

**If the chipper is still plugged or the engine has shut down, the jammed material must be removed by hand.**

### CAUTION!

The chipper blades are very sharp. Use caution when reaching into the rotor compartment to clear stuck material.

W026

- Remove the rotor housing flange bolt and open the housing. Clear out any jammed material inside.

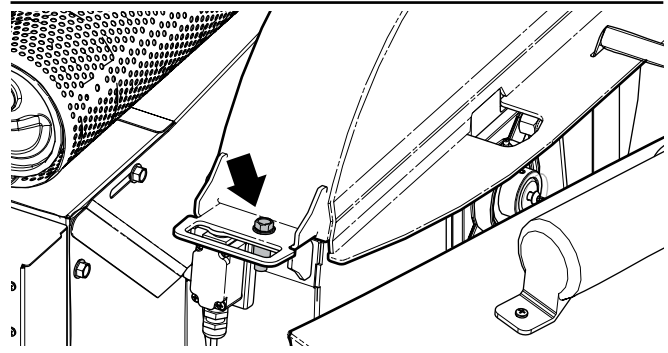



Fig. 42 – Rotor Housing Flange Bolt

 **NOTE:** As a safety precaution, the engine will not start if the rotor hood is open.

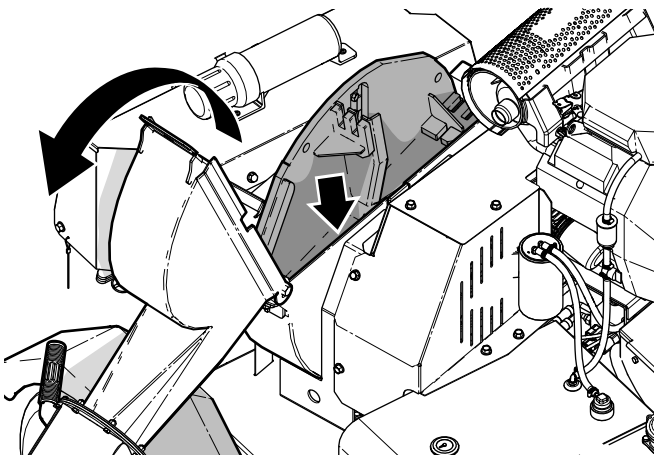

Fig. 43—Upper Rotor Housing

5. Pull out any material remaining in the feed hopper and discharge hood. Use a stick to free up any material jammed into the discharge hood.
6. Make sure all the material is removed and nothing is jammed or wedged between the input opening and the rotor before start up.

**If debris remains jammed or wedged between the input opening and the rotor, proceed to Step 7.**

If material gets jammed in the chipper to the point where the rotor speed slows to zero, the P3 system shuts the engine down.

### Chipper Severely Plugged

If the previous steps do not clear the blockage, the upper feed roller can be raised to clear the debris between the input opening and the rotor. That material can then be pulled back out of the feed table.

7. Remove the Bridge Guard Cover to access the end of the Toplink.
8. Remove the pin and extend the Toplink out so the rod end can be pinned to the Bridge.

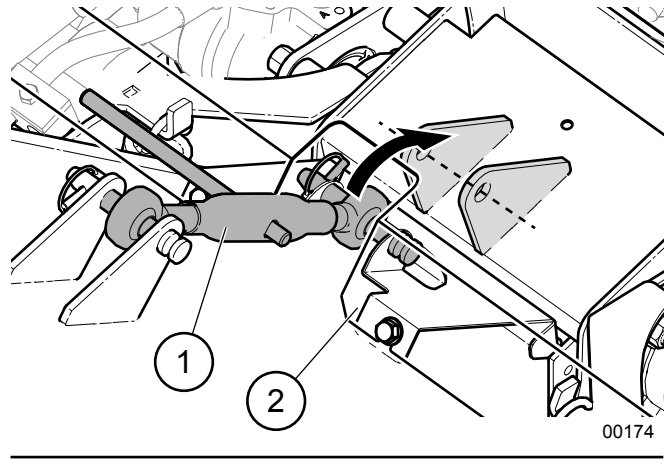

Fig. 44—Connect Toplink to Bridge

1. Toplink
2. Bridge Guard Cover

9. With the Toplink connected to the Bridge, wind in the Toplink so it shortens and raises the upper roller.

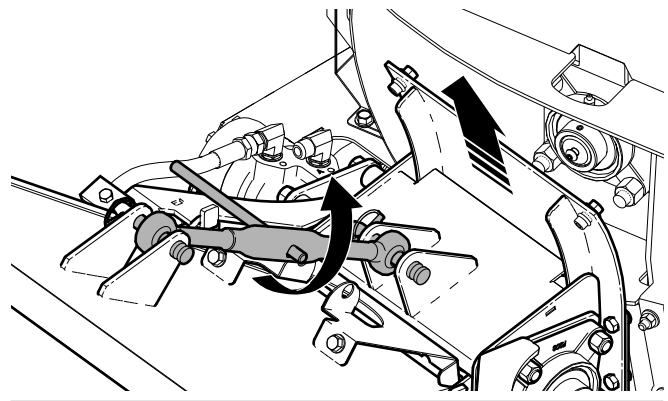

Fig. 45—Raise Upper Feed Roller

10. With the upper roller raised, carefully reach into the roller housing from inside the feed hopper to clear out the debris.
11. If required to dislodge material in or around the rotor, slowly turn the rotor by hand very carefully. **Do not reach into the roller housing while the rotor is moving.**
12. With the debris cleared, extend the Toplink to lower the upper roller back into position.
13. Disconnect the Toplink from the bridge, shorten it up, and reconnect it to its support. Reinstall the bridge cover.
14. Restart the chipper and resume operations.

**IMPORTANT! Do not operate the chipper with the Toplink connected to the bridge. Damage to the machine can occur.**



## 5.13 Transporting

Follow these steps before transporting the machine.

1. Turn the engine off and clean the machine. Remove all debris.
2. Close the fuel valve.

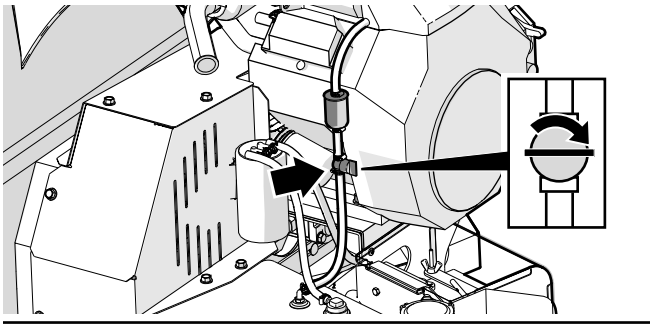
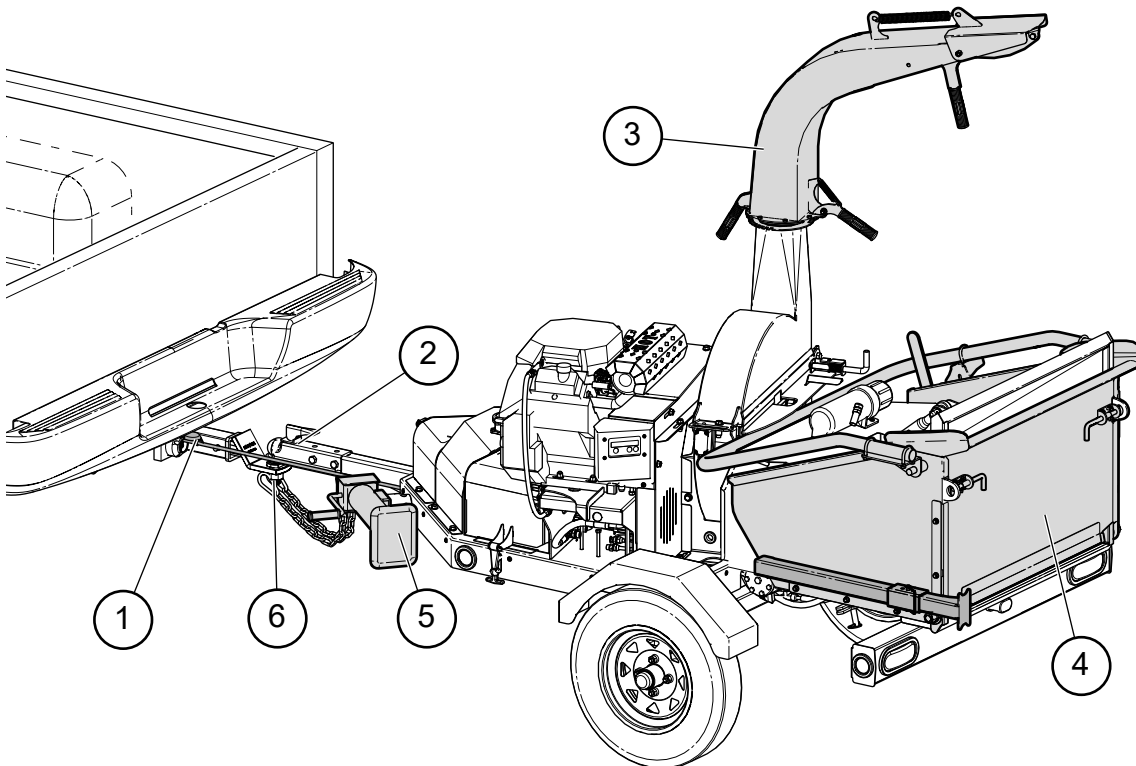

Fig. 46—Close Fuel Valve

3. Swing feed table up into the upright position. Secure it with the latches.
4. Make sure the chipper is securely attached to the tow vehicle. Connect the safety chains to the tow vehicle, crossed underneath the chipper tongue.

5. Raise the crank jack. Rotate and secure it in the transport position with the pin.
6. Connect the electrical harness cable to the tow vehicle. Check that all the lights and reflectors are in place, clean, and working.
7. Turn the discharge hood toward the feed table so it is pointed towards the rear of the machine.
8. Check tire air pressure. Inspect tires for any damage. Check lug nut torque and tighten if necessary.
9. Inspect and replace any axle dust caps if damaged or leaking.
10. Check that all components on the chipper are secure for travel. Check for any loose tools or other items. Make sure the toolbox cover is closed.

Review Transporting Safety rules *page 10*.



00134

Fig. 47—Wood Chipper Transport Position

1. Light Harness Connected
2. Ball Hitch Secured
3. Chute Turned
4. Feed Table Stowed and Latched
5. Jack Leg Raised
6. Safety Chains Attached

## 5.14 Storage

- If the machine is not going to be used for a period of time, put the chipper away in storage.
- Store the unit in an area away from human activity.
- Do not let children play on or around the stored machine.
- Store the unit in a dry, level area.
- Perform the following measures to ensure a smooth start-up before putting the chipper back to work. Completely inspect all major systems. Replace or repair any worn or damaged components.

**IMPORTANT!** Review the engine owner's manual to prepare the engine for storage.

### 5.14.1 Placing Chipper in Storage

1. Store the chipper in an area away from human activity. It is best to store the machine indoors. If that is not possible, cover it with a water-proof tarp.
2. Add fuel stabilizer to the fuel tank. Start the engine and leave it operating for a few minutes to make sure the treatment gets throughout the fuel system. Fill the fuel tank to prevent condensation.
3. Close the fuel valve.

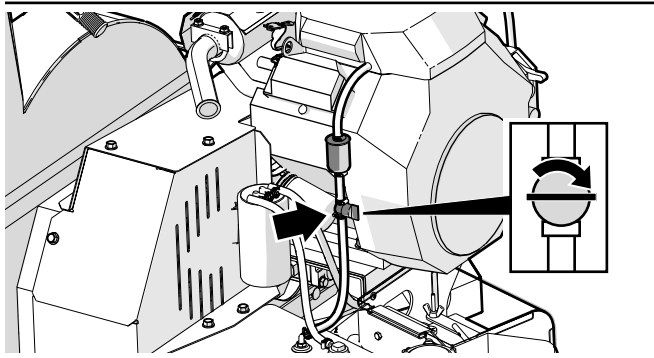

**Fig. 48**—Close Fuel Valve

4. Remove the battery and store it indoors. Connect a battery maintainer to keep it fully charged. Check it monthly.
5. Inspect all rotating parts and remove any entangled material. Remove all debris from the machine.
6. Thoroughly clean the machine.
7. Grease the machine and lubricate all hinges.
8. Check the condition of the belts and pulleys. Replace or adjust as required.
9. Raise up the feed table and secure it. Rotate the discharge chute towards the back of the machine.
10. Touch up all paint nicks and scratches to prevent rusting.

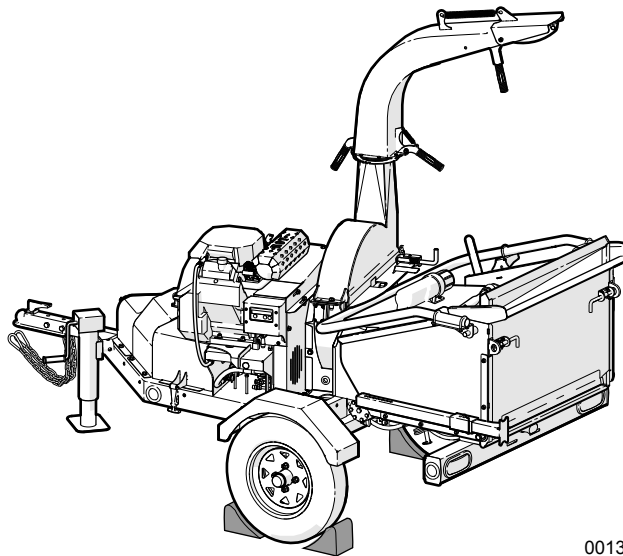

00135

**Fig. 49**—Storage Preparation

### 5.14.2 Removing from Storage

1. Check through the measures listed in the Pre-operation Checks. See *page 33*.
2. Review the Safety (*page 49*) and Operation procedures (*page 36*).
3. Install and reconnect the battery.
4. Open the fuel valve.

## 6. Service and Maintenance

### WARNING!

**Risk of serious personal injury. Stop engine before performing ANY service or maintenance procedure. Reinstall all covers and shields removed before putting machine back into service.**

W033

### WARNING!

**Shut down the machine and allow it to cool before performing any service, maintenance, or inspection procedure. Engine components and oil may be hot enough to cause injury.**

**Make sure the machine is in a Safe Condition to work on. Review Maintenance Safety beforehand.**

W041

### 6.1 Maintenance Safety

- Always place the machine in a safe service position before performing any service work, maintenance procedures, or storage preparation. The **Safe Condition** is as follows:

#### SAFE CONDITION

- Shut off engine. Remove ignition key.
- Make sure all moving parts have stopped.
- Disconnect battery ground (-) cable.
- Block or chock wheels.

- Follow good shop practices:
  - Keep service area clean and dry.
  - Be sure electrical outlets and tools are properly grounded.
  - Use adequate light for the job at hand.



- Never operate the machine or the towing vehicle in a closed building. The exhaust fumes may cause asphyxiation.
- Allow the engine to cool before performing maintenance. Engine components and oil may be hot enough to cause injury.
- Never work under equipment unless it is properly supported.

- When performing any service or maintenance work always use personal protective equipment.
- Where replacement parts are necessary, use only OEM parts to restore your equipment to original specifications. The manufacturer is not responsible for injuries or damages caused by use of unapproved parts or accessories.
- Inspect and tighten all bolts, nuts and screws. Check that all electrical and fuel connections are properly secured.
- When completing a maintenance or service function, make sure all safety shields and devices are installed before placing chipper in service.
- A When cleaning any parts, do not use gasoline. Use a cleanser designed for that purpose.
- Always use proper tools in good condition. Make sure you understand how to use them, before performing any service work.

### 6.2 Fluids and Lubricants

#### 1. Engine Oil

SAE 10W-30 or 5W-30 motor oil is recommended for general use. **Refer to the engine manufacturer's manual for maintenance and service information.**

#### 2. Grease

Use an SAE multi-purpose high temperature grease with extreme pressure (EP) performance. Also acceptable is an SAE multipurpose lithium-based grease.

#### 3. Engine Fuel

This engine is certified to operate on unleaded gasoline with a pump octane rating of 86 or higher (a research octane rating of 91 or higher).

#### 4. Hydraulic Oil

Use Dexron® III ATF for all operating conditions. Dexron VI or Mercon® are acceptable substitutes.

#### 5. Storing Lubricants

Your machine can operate at top efficiency only if clean lubricants are used. Use clean containers to handle all lubricants. Store them in an area protected from dust, moisture and other contaminants.

## 6.3 Maintenance Schedule

Perform maintenance procedures at time shown or hour interval, whichever comes first.

<b>As Required</b>	
Check the condition of all hydraulic lines, hoses and fittings. Replace any that are damaged.	
Visually check drive belt tension.	
Remove entangled material from chipper.	
Check that all fasteners are tight. Check wheel lug torque. See <i>page 61</i> .	

<b>Every 8 hours or Daily</b>	
Check engine oil level.	See <i>page 35</i>
Check hydraulic oil level.	See <i>page 35</i>
Perform Pre-operation check	See <i>page 33</i>

<b>Every 50 hours or Annually</b>	
Clean engine air filter	See <i>page 49</i>
Check drive belt tension and sheave alignment	See <i>page 52</i>
Check rotor blade sharpness.	See <i>page 53</i>
Inspect hydraulic oil quality	See <i>page 35</i>
Inspect battery	See <i>page 50</i>
Check ledger knife sharpness	See <i>page 54</i>
Check twig breaker	See <i>page 55</i>
Grease entire machine	See <i>page 45</i>

<b>Every 100 hours or Annually</b>	
Change engine oil	See engine manual
Check tire pressure	See rating on tire sidewall
Change hydraulic oil filter	See <i>page 49</i>
Change engine air filter	See <i>page 49</i>
Clean machine. Remove debris and entangled material.	—
Change fuel filter	See <i>page 56</i>

## 6.4 Grease Points

Use a hand-held grease gun for all greasing. Pump one shot of grease per fitting.

- Wipe grease fitting with a clean cloth before greasing to avoid injecting dirt and grit.
- If fittings do not take grease, remove and clean them thoroughly. Replace grease fittings as necessary.

Location	Grease Points – Every 50 hours of operation or annually
1	Rotor Main Shaft – Rear
2	Upper LH Roller Bearing
3	Lower LH Roller Bearing
4	LH Wheel Bearing
5	Trailer Jack

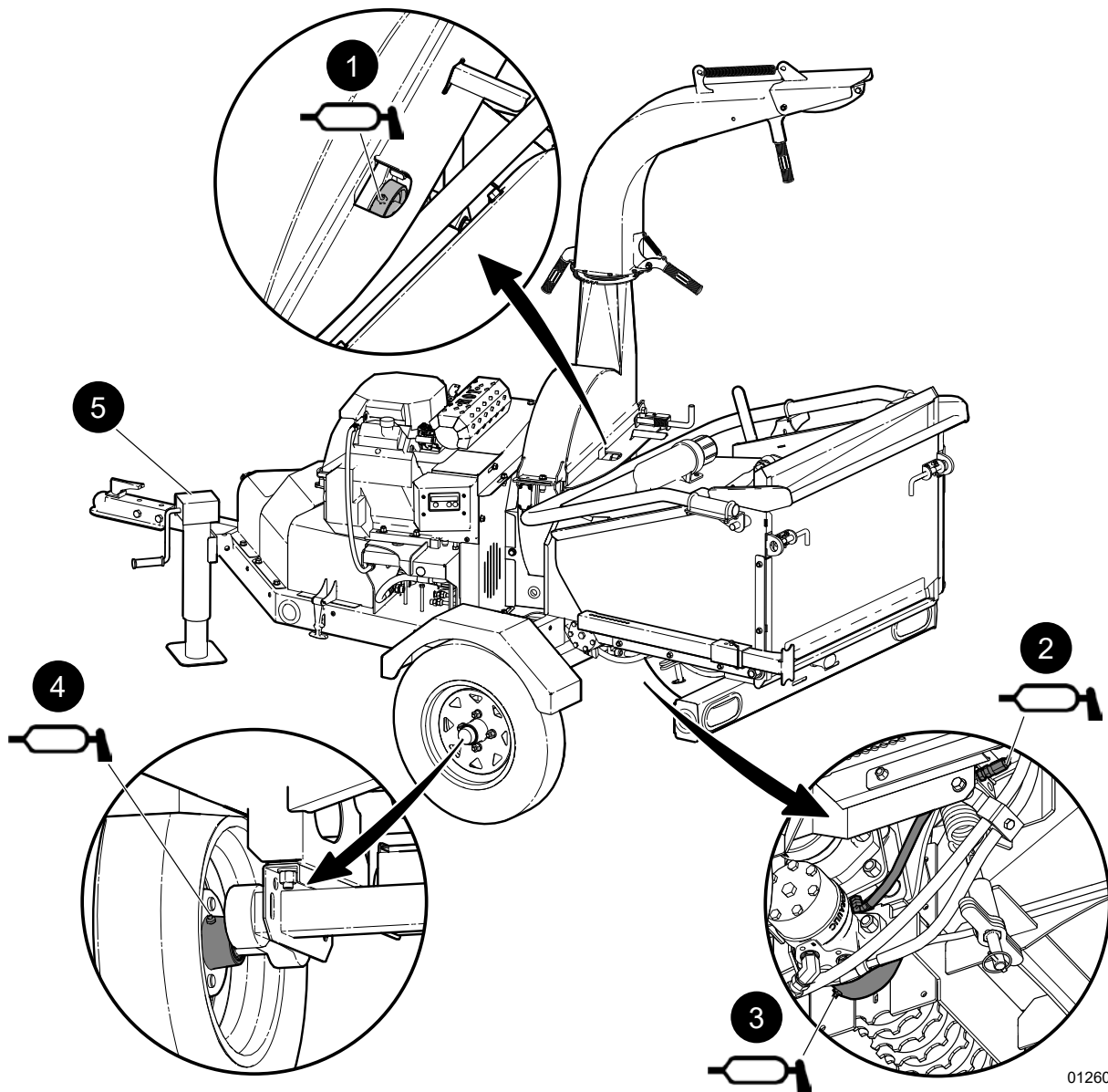

01260

Fig. 50 – Grease Points – 50 Hours of Operation or Annually

Location	Grease Points – Every 50 hours of operation or annually
6	Rotor Main Shaft – Front
7	Upper RH Roller Bearing
8	Lower RH Roller Bearing
9	RH Wheel Bearing
10	Feed Control Linkage

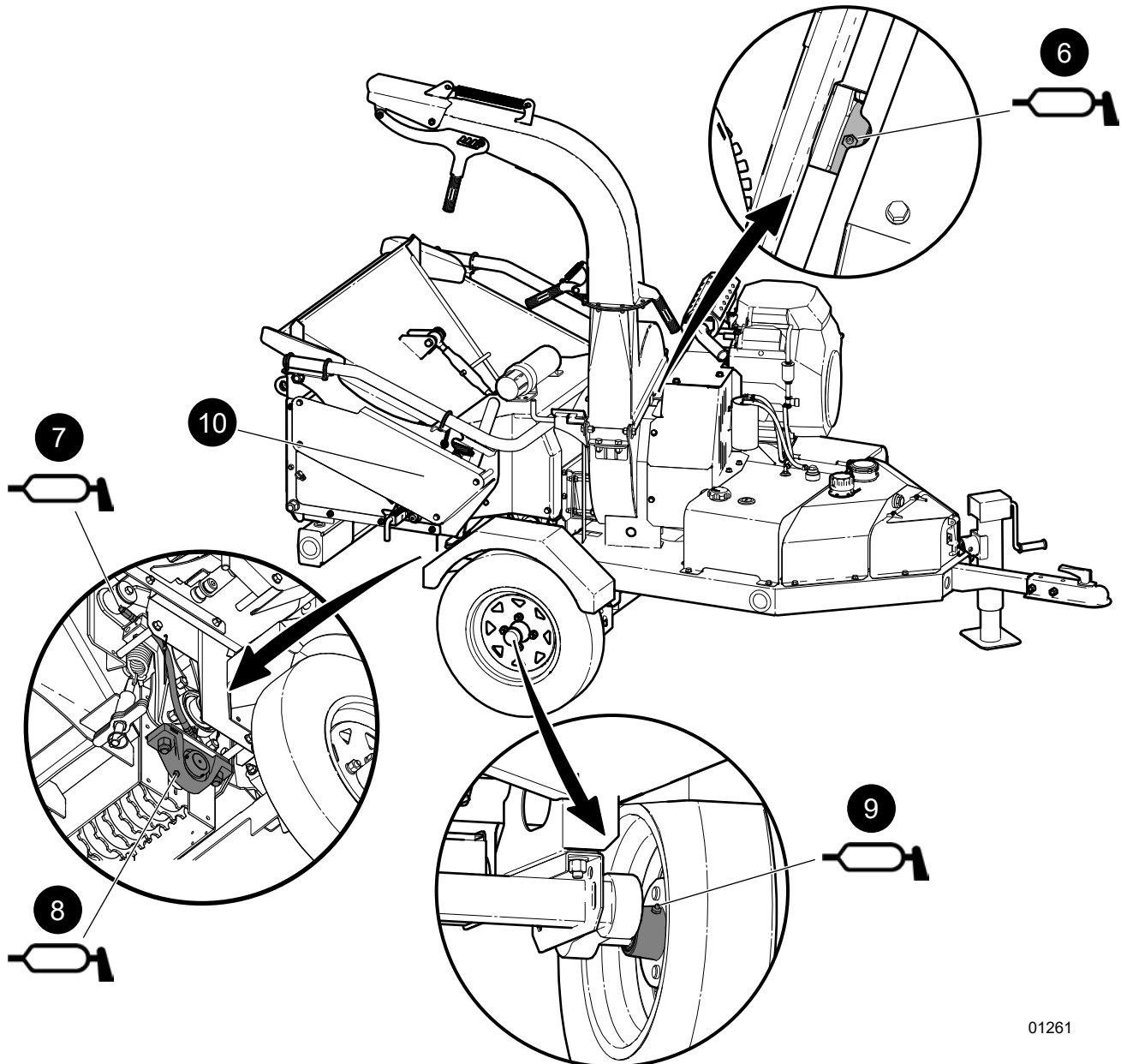

01261

Fig. 51 – Grease Points – 50 Hours of Operation or Annually

## 6.5 BXTR5224 Hydraulic Circuit

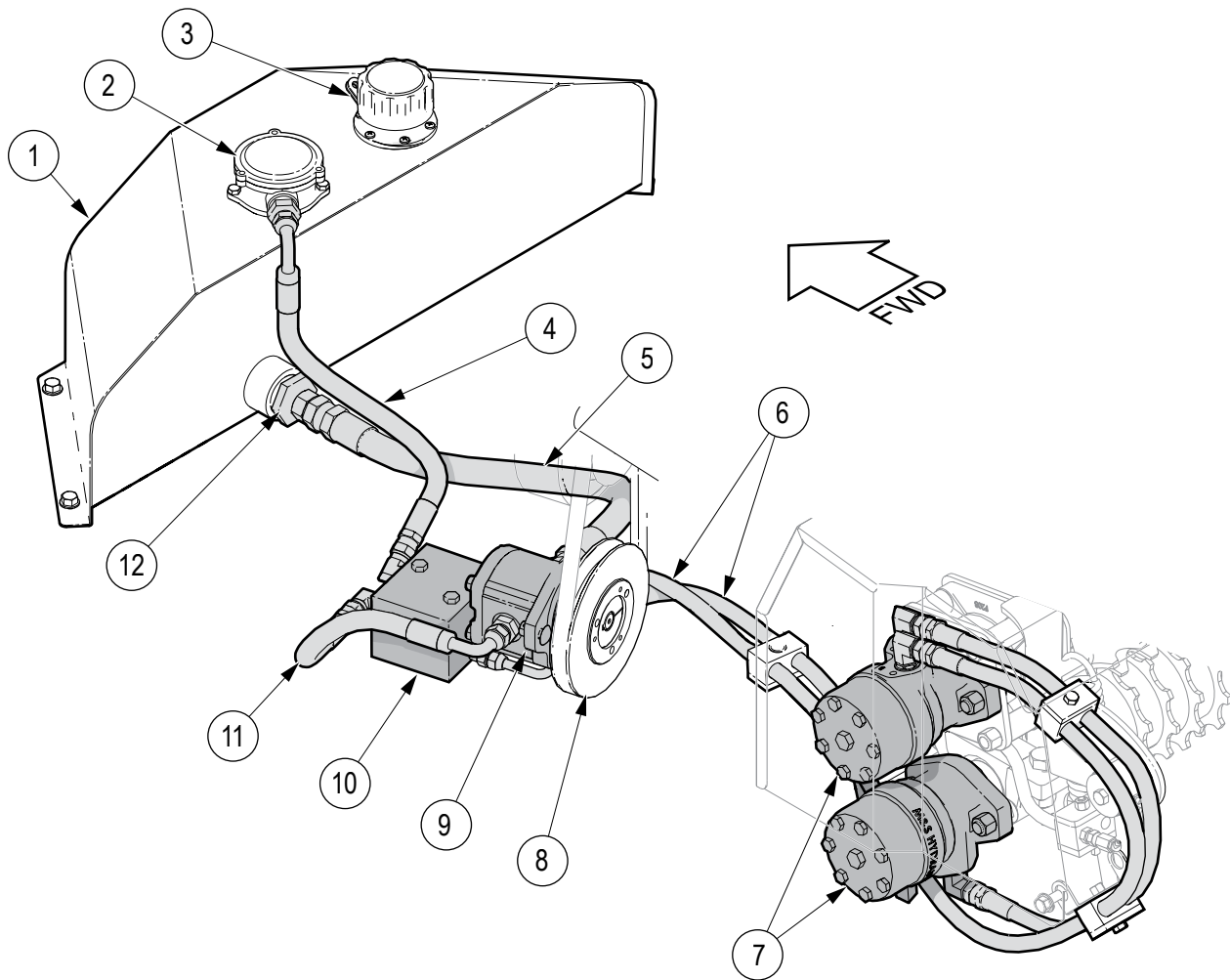

00306

Fig. 52 – BXTR5224 Hydraulic Circuit

1. Hydraulic Tank
2. Return Filter
3. Filler Breather Cap
4. Return Line
5. Suction Line
6. Pressure Lines
7. Feed Roller Hydraulic Motors
8. Pump Drive Sheave
9. Hydraulic Gear Pump
10. Control Valve
11. Pressure Line
12. Suction Strainer

## 6.6 Hydraulic Oil – Changing

### CAUTION!



**Risk of burns to exposed skin. Hydraulic oil becomes hot during operation. Hoses, lines, and other parts become hot as well. Wait for the oil and components to cool before starting any maintenance or inspection work.**

W028

**Change the hydraulic oil at 100 hours of operation or annually. Clean the return filter and suction strainer in the hydraulic tank at the same time.**

- Hydraulic oil type: **Dexron III ATF.**
- Hydraulic oil tank capacity: **5 US gal (19 L)**

The hydraulic tank drain plug is located under the machine. An Allen wrench is required to remove it.

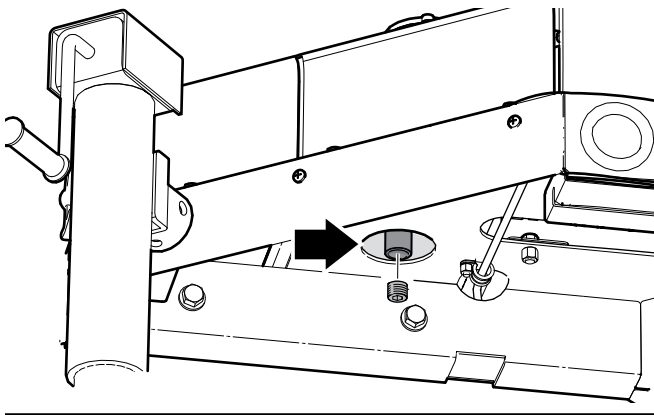

**Fig. 53**–Hydraulic Tank Drain Plug

### Procedure

1. Have a drain pan ready of suitable capacity.
2. Clean the area around drain and remove the drain plug.
3. Allow the oil to fully drain, then flush the tank. Dispose of used oil in an environmentally acceptable fashion.
4. Install the drain plug.
5. Clean the filter suction strainer before filling the tank.

### 6.6.1 Clean Suction Strainer

With the hydraulic tank emptied, the suction strainer should be removed and cleaned. The strainer is made of stainless steel screen and is reused.

The suction strainer is located on the back of the tank, between the fuel tank and the battery box.

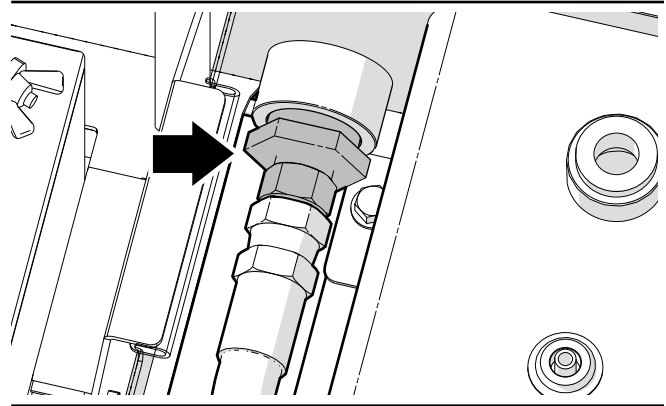

**Fig. 54**–Suction Strainer on Hydraulic Tank

1. Remove the suction hose, then remove the strainer.

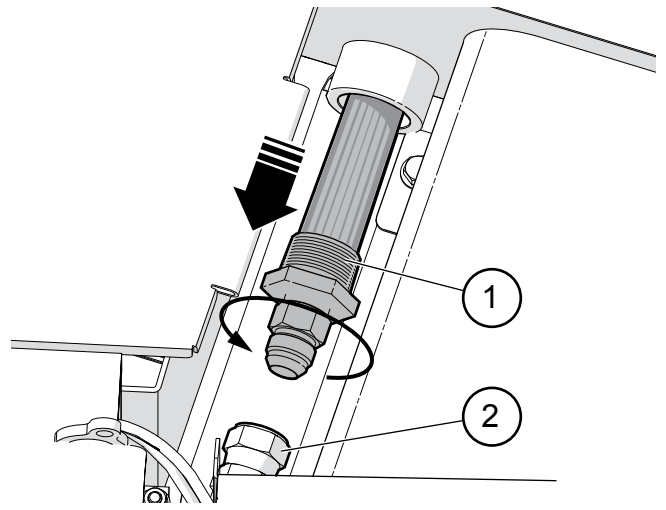

**Fig. 55**–Suction Strainer on back of Hydraulic Tank

1. Suction Strainer
  2. Suction Hose
2. Place the suction strainer in a solvent tank and use a small brush to clean it. Examine the strainer screen and replace it if there are holes or damage.
  3. Dry the suction screen thoroughly, then re-install.



## 6.6.2 Hydraulic Oil Filter – Cleaning

With the hydraulic tank emptied, the hydraulic return filter should be removed and cleaned. The filter is made of stainless steel screen and is reused.

The filter is located on top of the hydraulic oil tank.

### Procedure

#### CAUTION!



**Risk of burns to exposed skin. Hydraulic oil becomes hot during operation. Hoses, lines, and other parts become hot as well. Wait for the oil and components to cool before starting any maintenance or inspection work.**

W028

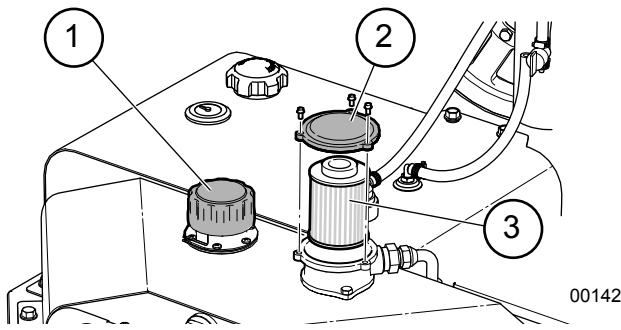

00142

**Fig. 56**—Hydraulic Oil Filter Element

1. Hydraulic Tank Filler Cap
2. Oil Filter Cover
3. Hydraulic Oil Return Filter Element

1. Have a drain pan ready to catch any dripping oil.
2. Remove the three screws on the filter cover and pull the cover off.
3. Remove the filter element and clean the bottom of the bowl.
4. Check that the O-rings are not damaged. If they are, replace them.
5. Place the filter element in a solvent tank and use a small brush to clean it. Examine the screen and replace it if there are holes or damage.
6. Reinstall the filter cover and tighten the screws to **44 lbf•in (5 N•m)**.
7. Fill the tank with clean oil. The proper oil level is when it is visible in half the glass window.

## 6.7 Engine Air Cleaner

**Check air cleaner every 50 hours of operation. Check it more frequently during dusty, dirty conditions.**

**Change air filter elements at 100 hours of operation or annually.**

A dirty air filter can restrict air flow to the carburetor, reducing engine performance. If the engine is operated in very dusty areas, clean the air filter more often than specified.

**IMPORTANT! Operating the engine without an air filter, or with a damaged air filter, can allow dirt to enter the engine, causing rapid engine wear. This type of damage is not covered by Warranty.**

### Inspection

Remove the air cleaner cover and inspect the filter elements. Clean or replace dirty filter elements. Always replace damaged filter elements.

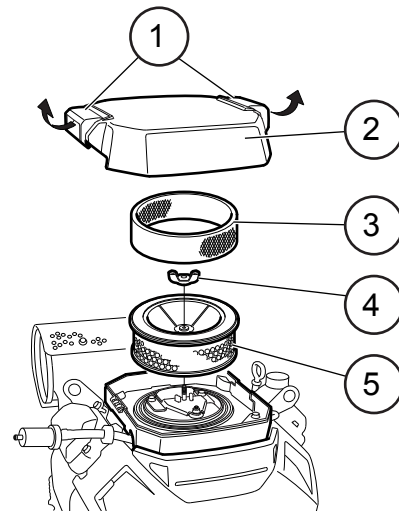

00140

**Fig. 57**—Engine Air Cleaner

1. Air Cleaner Cover Latches
2. Air Cleaner Cover
3. Wing Nut
4. Paper Filter Element
5. Foam Filter Element

 **NOTE:** Refer to the engine manual for further information on servicing the air cleaner.

## 6.8 Servicing the Battery

Review *Battery Safety* on page 10.

### CAUTION!

**Risk of explosion or fire! Do not let metal objects come in contact with the battery terminals. Arcing can cause a fire or explosion. Cover terminals if working near batteries.**

W021

### CAUTION!

**Risk of burns! Battery electrolyte is extremely corrosive and poisonous. Contact with the eyes, skin or clothing can result in severe burns or other serious personal injury. If contact occurs seek medical attention immediately. Handle batteries carefully.**

W029

### CAUTION!

**Battery posts, terminals and related accessories contain lead and lead compounds. These chemicals are known to cause cancer and birth defects or other reproductive harm. Wash hands after handling.**

W031

### 6.8.1 Removing the Battery

1. Disconnect negative (–) cable first, then positive (+) cable.
2. Remove battery hold-down bracket and battery from machine.

### 6.8.2 Installing the Battery

1. Install battery hold-down bracket.
2. Coat terminals with dielectric grease or petroleum jelly.
3. Connect positive (+) cable first, then negative (–) cable.

### 6.8.3 Cleaning the Battery

1. Disconnect negative (–) cable first, then positive (+) cable.
2. Clean battery cable ends and terminals with wire brush. Rinse with a weak baking soda solution.
3. Coat terminals with dielectric grease or petroleum jelly.
4. Connect positive (+) cable first, then negative (–) cable.

### 6.8.4 Charging the Battery

Be familiar with procedures for charging and testing a battery. Read and follow the manufacturer's instructions for the battery charger.

### WARNING!

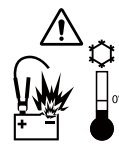

**Charging a frozen battery can cause it to explode. Warm the battery to 60 °F (16 °C) before charging.**

W030

Remove the battery from the machine to recharge it.

1. Use a battery carrier to lift the battery or place hands at opposite corners to avoid spilling electrolyte.
2. Place battery in a well-ventilated area.
3. Connect positive (+) lead of charger to positive (+) terminal, and negative (–) lead to negative (–) terminal.
4. Charge battery according to the instructions from battery charger manufacturer and battery manufacturer.

### 6.8.5 Jump Starting

Booster battery must be 12-volt, or installed in a system that is 12-volt, negatively grounded.

1. Connect positive (+) jumper cable to positive terminal of discharged battery.
2. Connect the other end of the same jumper cable to positive (+) terminal of booster battery.
3. Connect one end of the second jumper cable to negative (–) terminal of booster battery.
4. Make the final jumper cable connection to engine block or the furthest ground point, away from the discharged battery and fuel tank.
5. Start engine.
6. After engine starts leave cables connected for one to two minutes.
7. Disconnect jumper cables in reverse order of installation.
8. Operate unit as normal to charge battery.

## 6.9 Hydraulic Pump Drive Belt Replacement

Allow the engine and components to cool beforehand.

### Procedure

1. Remove the lower drive belt shield (1).

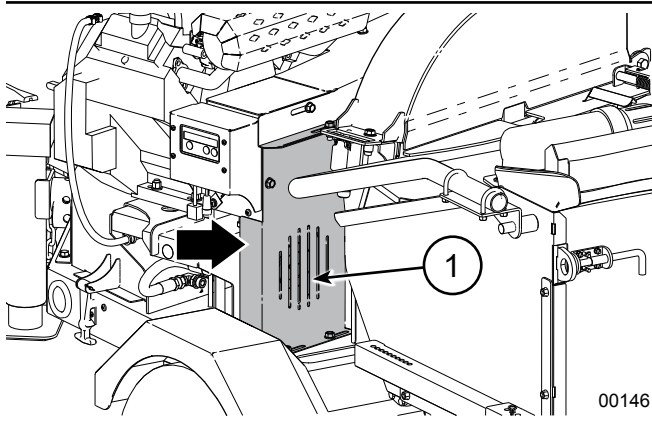

Fig. 58—Lower drive belt shield

2. Loosen, but do not remove the two bolts holding the pump mounting plate (2).

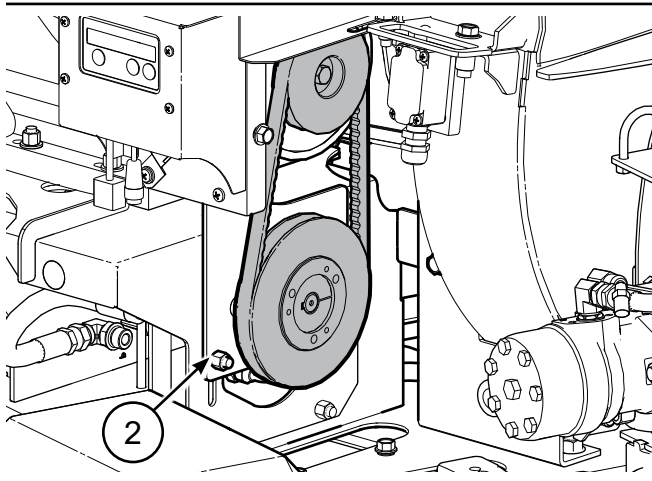

Fig. 59—Bolts holding pump mounting plate

3. Loosen the jam nut (3) slightly on the top of the adjustment bolt.
4. Back off the belt tension adjuster nut (4) on the bottom of the mounting plate. Loosen enough so the drive belt can be removed.

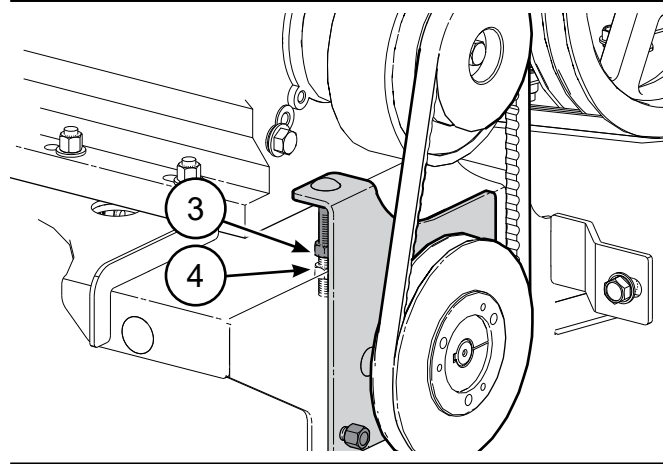

Fig. 60—Belt Tension Adjuster

5. Install the new belt and adjust belt tension.

## 6.10 Pump Drive Belt Tension

Proper drive belt tension is set by checking belt deflection.

### Procedure

1. With the belt installed, tighten the belt tension adjuster nut (item 4, Fig. 60) to remove the slack from the belt.
2. Push on the drive belt by hand to check its deflection. It should not deflect more than 3/8"–7/16" (10 mm–12 mm). Adjust accordingly.

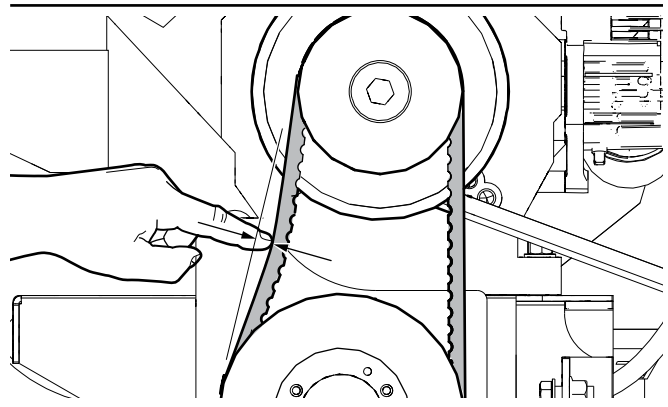

Fig. 61—Drive belt tension

3. With the correct belt deflection set, tighten the jam nut.
4. Recheck belt tension after 10 hours of operation.

## 6.11 Rotor Drive Belt Replacement

Allow the engine and components to cool beforehand.

### Procedure

1. Remove both upper and lower drive belt shields (1).

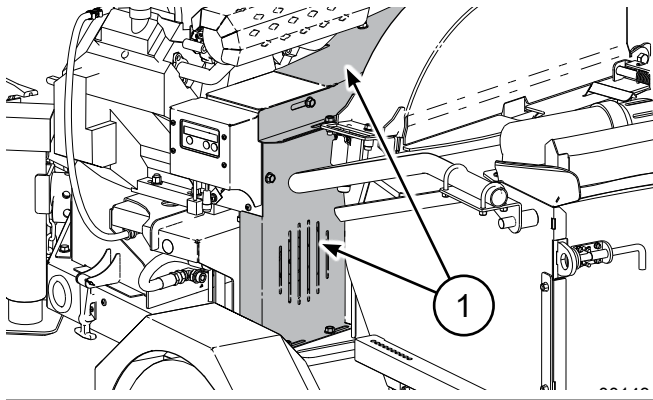

Fig. 62—Upper and lower drive belt shields

2. Remove pump drive belt. See Pump Drive Belt Replacement page 51.
3. Loosen (do not remove) the four engine mount nuts (3) that secure the engine sub frame to the main frame.

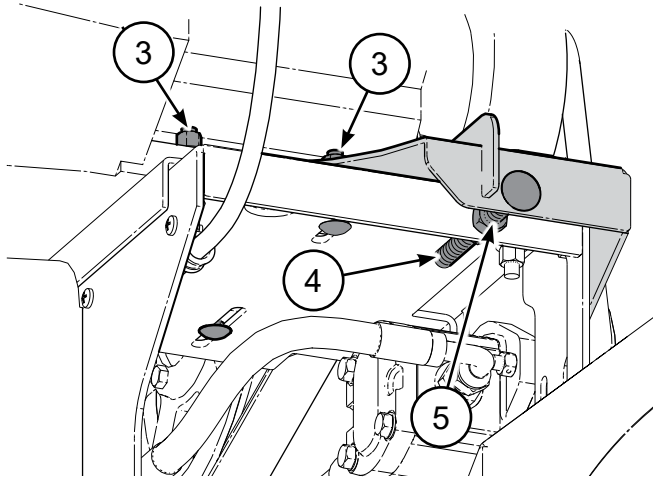

Fig. 63—Engine mount

4. Loosen the jam nut on the belt tension adjuster (4).
5. Back off the belt tensioning nut (5) until the drive belt is loose enough to remove.
6. Install the new belt, check sheave alignment and adjust belt tension.

**IMPORTANT!** Check sheave alignment after changing the drive belt.

## 6.12 Sheave Alignment

### Procedure

1. Place a straight edge along the front face of the rotor sheave. Make sure the space is equal between the drive belt along the length of the straight edge. Adjust accordingly.

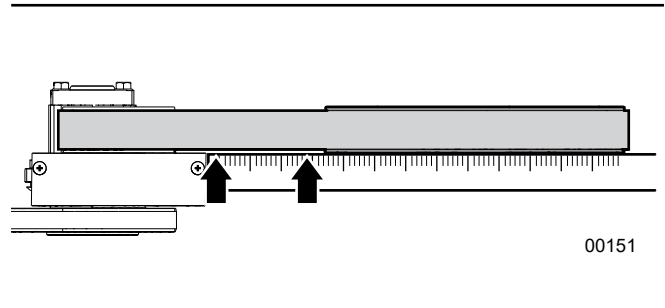

Fig. 64—Sheave alignment

## 6.13 Rotor Drive Belt Tension

Proper drive belt tension is set by adjusting belt deflection.

### Procedure

1. Turn in the belt tension adjuster nut to set belt tension.
2. Push on the drive belt by hand to check its deflection. It should not deflect more than 3/8"–7/16" (10 mm–12 mm). Adjust accordingly.

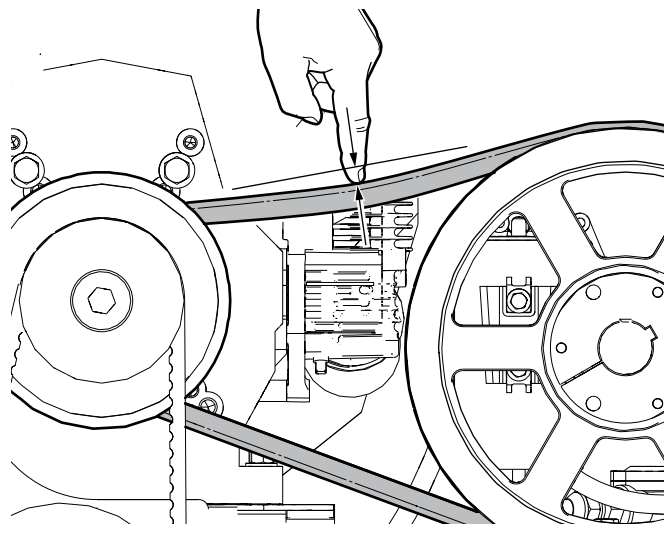

Fig. 65—Rotor drive belt tension

3. Tighten the jam nut.
4. Recheck belt tension after 10 hours of operation.

## 6.14 Upper Feed Roller Tension Adjustment

The feed rollers pull material from the hopper into the chipper. The lower roller is fixed. The upper roller is mounted on hinged pivot arms so it can move up and down with different sizes of material. Spring tension on the upper pivot arms hold the roller down on the material as it is fed into the chipper.

Adjust spring tension tighter for smaller material, and looser for larger material.

If spring tension needs to be adjusted, follow these steps:

### Procedure

1. On the underside of the machine, loosen the jam nuts (1) on the spring tensioners. Hold the upper nut with a wrench while loosening the jam nut.

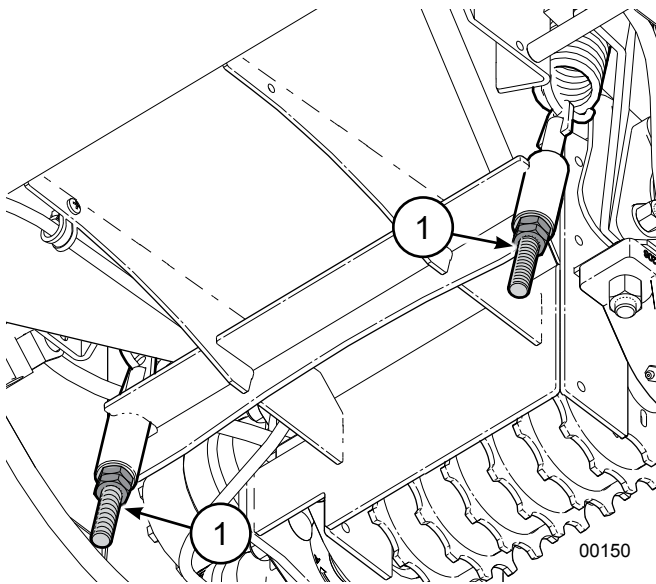

Fig. 66—Upper feed roller tensioner (US model shown)

2. Turn the adjuster nut to set spring tension as required. The upper roller should grip material and move up and down with different material sizes.
3. Hold the adjuster nut with a wrench and tighten the jam nut.

**IMPORTANT!** Set tension on both sides equally. Measure the length of adjustment threads as a check.

## 6.15 Rotor Blades – Changing

Check rotor blade sharpness daily.

Check blade sharpness more often if processing material with a lot of sand, soil or dirt in it. If the chipper is not pulling the material or material has to be pushed into the chipper, the rotor blades are probably dull.

Keeping the blades sharp reduces the amount of power required during operation. Reverse or sharpen the blades if the cutting edge becomes dull.

### Procedure

1. Remove the blades from the rotor to sharpen. Sharpen at a 45° angle to provide the best cutting effect.

**IMPORTANT!** Make sure equal amount of material is removed from each blade when sharpening to maintain proper rotor balance.

### CAUTION!

Risk of getting hands pinched or wedged between lower rotor housing and rotor. Turn rotor slowly and be aware of hand positioning.

W032

2. Install rotor blades with leading edge out, towards the ledger blade. Tighten the blade mounting bolts to **45 lbf•ft (63 N•m)**.

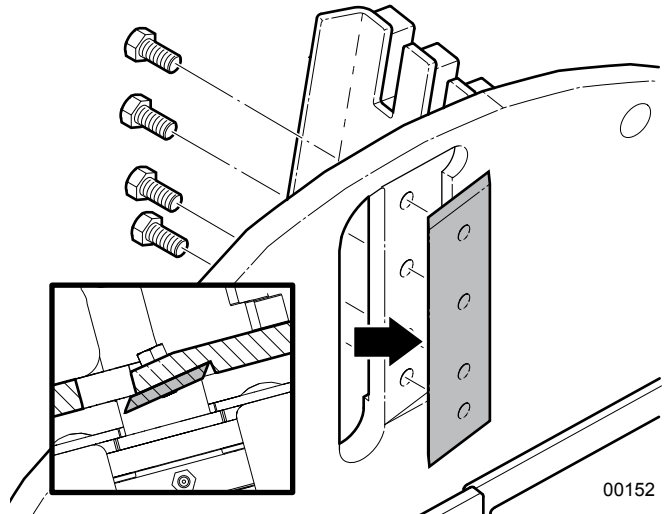

Fig. 67—Rotor blade leading edge

**IMPORTANT!** If replacing or sharpening a blade, do the opposite one on the rotor as well to maintain rotor balance. Ledger knife clearance must be equal.

## 6.16 Ledger Knife – Checking

Observe ledger knife performance daily. Check the ledger knife sharpness every 50 hours.

The ledger knife is bolted inside the lower rotor housing assembly. As the rotor turns, material fed into the chipper is sheared off at the ledger knife by the rotor blades.

When the corner of the ledger knife facing the rotor blade rounds over, the blade can be removed and re-installed with a different corner facing the rotor blade. Once all four corners have been rounded, remove the knife to sharpen or replace it.

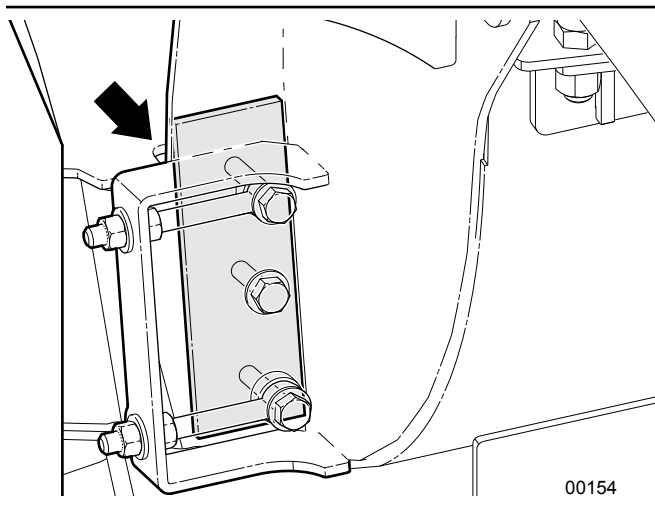

Fig. 68—Ledger knife inside lower rotor housing

To obtain the best chipper performance, check the clearance between the rotor blade and stationary ledger blade every 50 hours.

### 6.16.1 Ledger Knife Clearance

Use the ledger setting gauge to check knife clearance. **The thickness of the gauge is the correct ledger blade clearance.** If spacing is in excess of the gauge thickness, adjust the clearance.

**NOTE:** The actual clearance between the rotor blades and the ledger knife is 1/32"–1/16" (.76–1.52 mm).

## Checking

1. Open the upper rotor housing.



**Risk of getting hands pinched or wedged between lower rotor housing and rotor. Turn rotor slowly and be aware of hand positioning.**

W032

2. Turn the rotor by hand so that one rotor blade edge is next to the ledger knife.
3. Slide the end of the ledger gauge down between the rotor blade and the ledger knife.

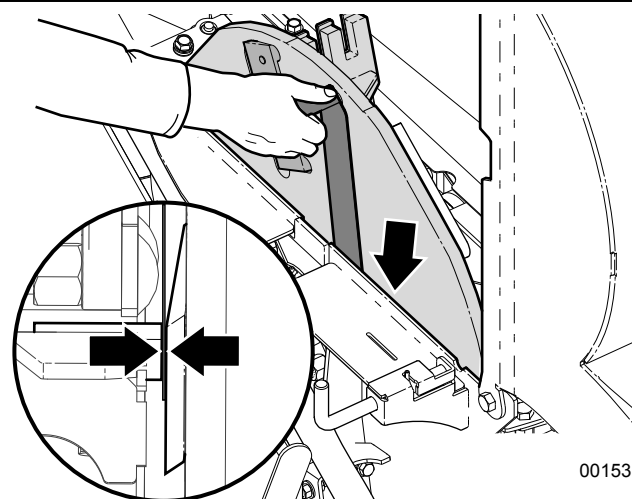

Fig. 69—Checking ledger knife clearance

4. Turn the rotor past the ledger knife with the gauge inserted between them to check clearance. The gauge should be tight. Check all four knives.

## Adjusting

5. Loosen the jam nuts on the outside of the ledger knife support.

6. Turn the adjuster nuts (2) clockwise so the ledger knife slides firmly up against the gauge inside the rotor housing. Remove the ledger knife gauge.
7. Tighten the jam nuts (1).

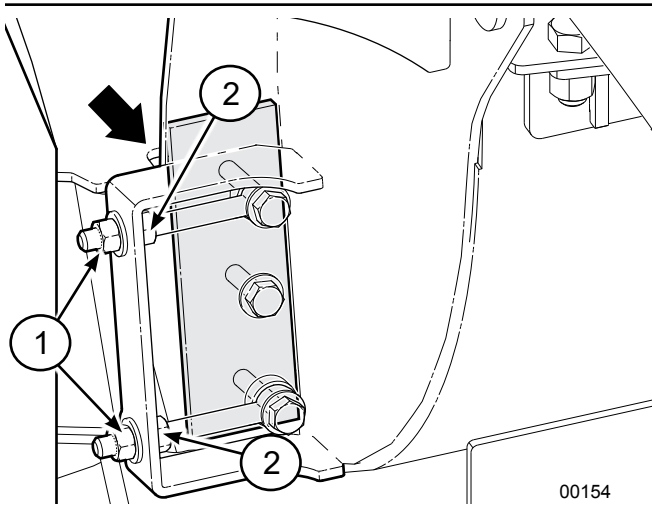

Fig. 70—Adjusting ledger knife clearance

## 6.17 Ledger Knife – Changing

The ledger knife is removed through the bottom of the chipper.

### Procedure

1. Loosen the outside jam nuts (1) and the inside adjuster nuts.
2. Remove the three bolts (2) holding the ledger knife in place to allow the blade to fall through the bottom of the chipper.

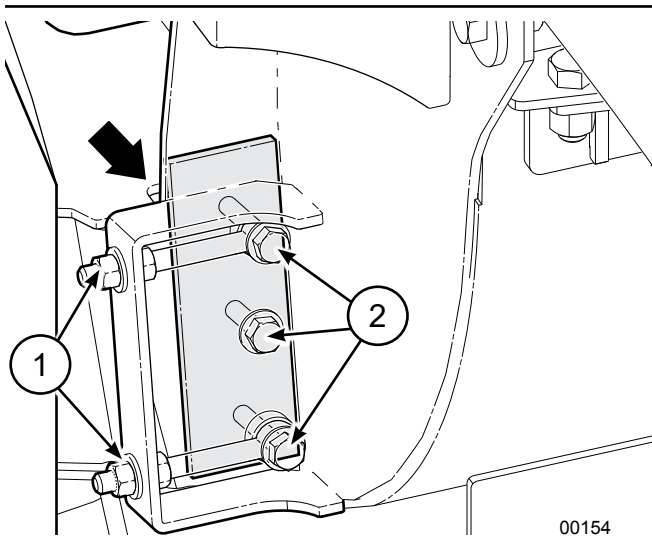

Fig. 71—Changing Ledger Knife

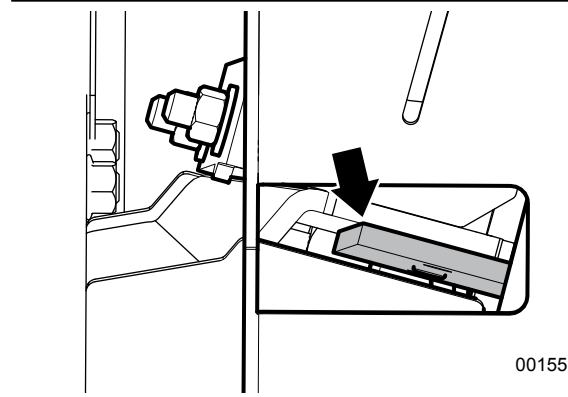

Fig. 72—View of Ledger Knife from underside of Chipper

3. Rotate the ledger knife or replace it.
4. Reverse the above steps to reinstall the knife.
5. Verify clearance before tightening.

## 6.18 Twig Breaker

Inspect the twig breaker for damage, bent or missing teeth every 50 hours.

The twig breaker is located inside the lower rotor housing. Material in the chipper is broken up into smaller pieces as the discharge paddles rotate past it.

A damaged or worn twig breaker should be replaced.

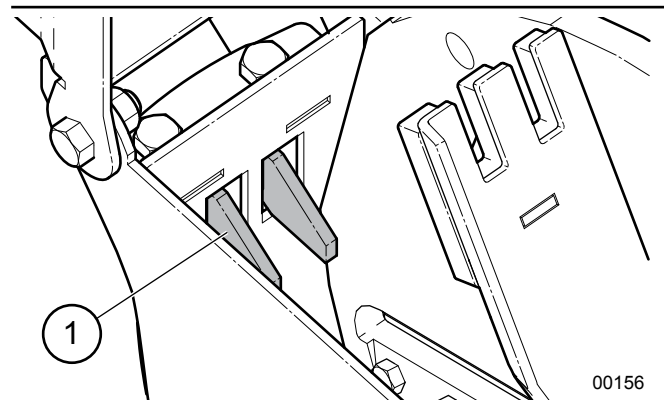

Fig. 73—Lower Rotor Housing

1. Twig Breaker

## 6.19 Fuel Filter – Changing

The fuel filter is located on the right-hand side of the engine. Allow the engine to cool before beginning.

1. Turn the fuel supply off at the fuel shut-off valve.
2. Remove the gear clamps on either side of the filter. Pull it off the hoses and install a new one.
3. Install and tighten the gear clamps, then turn the fuel supply back on.

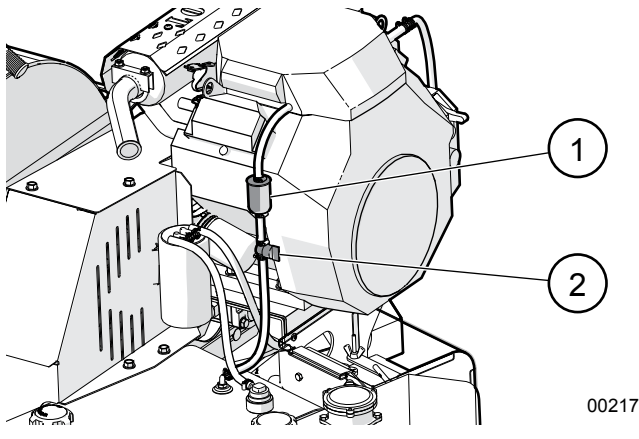

Fig. 74—Engine Fuel Filter

1. Fuel Filter
2. Fuel Shut-off Valve

## 6.20 Electrical System – General

**IMPORTANT!** When assembling or replacing wire harnesses, apply a thin coating of silicone dielectric grease to the harness connectors.

Clean off any corrosion or loose particles, then apply a small amount to the surfaces of the connectors where they meet. The grease helps to stop any possibility of future corrosion.

Reassemble the connection. Wipe off any grease that squeezes out.

**IMPORTANT!** If welding on the machine becomes necessary, sensitive electronic components must be removed from the machine beforehand. Welding can produce stray voltage spikes that can damage these items.

- Disconnect and remove the P3 Display and Controller from the machine.
- Disconnect/unhook the machine from the tow unit, tractor, or carrier machine.
- Disconnect the machine's battery (as equipped). Disconnect the negative battery cable first before disconnecting the positive battery cable.
- Place the welder ground clamp as close to the work area as possible. Keep the welder cables away from the control system electrical harnesses.



## 6.21 Troubleshooting

The following table lists some problems that may be encountered, with possible causes and solutions.

If a problem is persists after reading through the Troubleshooting section, contact your local dealer, distributor or Wallenstein. Have the serial number ready.

### Engine related issues

Refer to the Honda GX690 owner's manual.

### Clutch related issues

Refer to the Transfluid Fluid Coupler installation and maintenance manual.

### Brake and wheel bearing related issues

Refer to the Dexter® Torflex 1800 lb Axle, Brake and Hub Assembly service manual.

Problem	Cause	Solution
<b>Rotor does not turn.</b>	Obstructed discharge.	Clear debris from discharge chute.
	Rotor plugged.	Inspect and clear chipper hopper lower rotor housing and rotor.
	Clutch seized.	Replace.
<b>Material feeding in too slow.</b>	Engine or rotor speed to low.	Set throttle to increase rotor rpm.
	Blades or knives are dull or clearance incorrect.	Check rotor and ledger blades. Rotate, sharpen or replace.
	Rotor blade knife edge angle incorrect.	Re-sharpen rotor knives to specified 45° angle and check that blade is installed properly.
	P3 programing incorrect.	Adjust programming. See <i>page 25</i> .
	Slow hydraulic flow.	Dirty or plugged hydraulic filter. Change filter. See <i>page 49</i> .
		Hydraulic oil is contaminated. Inspect oil condition for dirt or foaming. Replace oil. See <i>page 48</i> .
	Lower roller is jammed (not cleaned out from last use).	Open lower roller clean out and remove debris. Jammed debris could freeze in colder weather.
Obstructed discharge.	Clear debris from discharge chute.	
<b>Unusual machine vibration while operating.</b>	Broken or missing rotor blade.	Replace.
	Rotor may be bent.	Check for rotor wobble. Replace rotor.
	Rotor bearings failed.	Replace.
	Loose fasteners.	Tighten. See torque tables <i>page 59</i> .
<b>Engine does not start.</b>	Upper rotor housing open.	Close upper rotor housing. Make sure interlock cable is connected.
	Interlock switch defective.	Check interlock switch. Replace.
	Interlock wiring harness damaged.	Inspect wiring harness. Repair or replace.
	Engine problem.	Refer to engine manufacturer's manual.
	Clutch seized.	Replace.
<b>Machine requires excessive power or stalls.</b>	Obstructed discharge.	Clear debris from discharge chute.
	Feeding in too much material.	P3 PULSE programing incorrect. Adjust programming. See <i>page 25</i> .
	Feeding material too quickly.	P3 PULSE programing incorrect. Adjust programming. See <i>page 25</i> .
	Rotor plugged.	Inspect and clear chipper hopper lower rotor housing and rotor.
	Green material does not discharge.	Allow material to dry or alternate between dry and wet material.
	Space between rotor blade and ledger knife too large.	Use ledger gauge tool to check clearance. See <i>page 54</i> .
	Dull blades.	Check rotor and ledger blades. Rotate, sharpen or replace. See <i>page 53</i> .
	Engine problem.	Refer to engine manufacturer's manual.

Problem	Cause	Solution
<b>Noisy drive belt, premature wear.</b>	Drive belts loose or worn.	Inspect drive belts. Adjust tension or replace if needed. See <i>page 52</i> .
	Wrong replacement belt.	Inspect drive belts. Replace. See <i>page 52</i> .
	Sheaves misaligned.	Check sheave alignment and adjust. See <i>page 51</i> .
	Rotor plugged.	Inspect and clear chipper hopper, lower rotor housing, and rotor.
	Belt tension too high.	Check belt tension and adjust.
	Sheaves worn.	Inspect sheaves and bearings. Replace if required.
	Oil or grease on drive system.	Check source of oil or grease and correct. Clean sheaves and belts. Belts may require replacement.
	Rotor bearings.	Check and replace if required.
<b>Poor Chip Quality.</b>	Dull blades.	Check rotor and ledger blades. Rotate, sharpen or replace. See <i>page 53</i> .
	Drive belts loose or worn.	Inspect drive belts. Adjust or replace if needed. See <i>page 51</i> .
	Poor quality material.	Material is small or rotting. Mix with higher quality material.
	Knife clearance incorrect.	Check and adjust as required. See <i>page 54</i> .
<b>Feed rollers intermittent or not turning</b>	Feed roll control bar set to stop.	Move to Forward or Reverse position.
	Engine speed not at or above minimum setting.	Set engine throttle for maximum rpm. Make sure engine is properly tuned. Adjust P3 programming. See <i>page 25</i> .
	P3 programming incorrect.	Check that P3 settings are at factory specifications. Reset if required. See <i>page 25</i> .
	P3 not receiving signal.	Inspect rotor sensor for damage. Replace unit if required.
		Inspect rotor sensor mount or sheave mounted indicator plate for damage or misalignment. Repair or replace.
		Check P3 controller for output signal. Replace unit if required.
		Check harness for bad ground connection.
	Inspect wiring harness for damage. Repair or replace if damaged.	
	P3 hydraulic control valve malfunction.	Inspect hydraulic control valve for damage. Check functionality.
	Feed control bar malfunction.	Check feed control bar switches. Replace, reposition pickup trigger.
	Slow hydraulic flow.	Filter is dirty. Change filter.
		Hydraulic oil is contaminated. Inspect oil condition for dirt, foaming. Replace oil.
	No electrical power.	Check battery, engine charging system for power.
Hydraulic motor slow.	Check hydraulic circuit, oil and motor condition. Replace if required.	
Roller drive key sheared.	Check and replace.	
Hydraulic pump fault.	Repair or replace.	
<b>Hydraulic oil overheating. Noisy hydraulic pump.</b>	Reservoir oil level is too low.	Fill reservoir until fluid is visible in sight glass.
	Dirty filter.	Change filter.
	Hydraulic oil contaminated.	Inspect oil condition. Check for dirt or foaming. Replace oil.
	Feed rollers binding.	Inspect bearings. Lubricate or replace.
	Lines crimped or pinched.	Inspect, repair or replace lines.
	Worn pump.	Check and replace.
	Line leak.	Inspect hydraulic lines and connections for leaks. Repair or replace.
	Pump leak.	Pump seals are worn. Replace.
	Pump noisy at startup.	Oil temperature too low. Allow machine to warm up before putting to work.

## 7. Specifications

Model	BXTR5224 Trailer wood chipper
<b>Engine</b>	Honda GX690, 22 hp (16.5 kW)
<b>Drive System</b>	Rotor: Dual Belt, Auto Engage P3-protected Centrifugal Clutch
<b>Chipper Housing Opening (Height x Width)</b>	5-1/4" x 9" (13.3 cm x 23 cm)
<b>Capacity</b>	5" (13 cm) diameter / 9" (23 cm) slab
<b>Chipper Hopper Opening (Height x Width)</b>	24" x 35" (61 cm x 89 cm)
<b>Chipper Rotor Diameter / Weight</b>	25" (63.5 cm) diameter @ 117 lb (53 kg)
<b>Feed System</b>	P3 PULSE – electronic monitoring and feed control with auto clutch protection
<b>Max Feed Rate</b>	85 fpm
<b>Knife Type</b>	Hardened tool steel
<b>Number of Rotor Knives</b>	2 full knives
<b>Rollers</b>	Dual horizontal with hydraulic drive
<b>Discharge Hood Rotation</b>	270°
<b>Discharge Hood Height</b>	80" (203 cm)
<b>Hydraulic Tank</b>	5 US gal (19 L)
<b>Fuel Tank</b>	6.5 US gal (24.6 L)
<b>Mounting System</b>	Trailer 2" (50.8 mm) ball and coupler
<b>Dry Weight</b>	1425 lb (646.4 kg)
<b>Dimensions (Length x Height x Width)</b>	Open–126" x 80" x 54" (320 cm x 203 cm x 137 cm) Closed–107" x 80" x 54" (272 cm x 203 cm x 137 cm)
<b>Distance of feed roller to edge of feed table to ground.</b>	70" (178 cm) (Note: Does not meet WorkSafe BC or OSHA. Not intended for workplace use.)
<b>Tire Size</b>	5.30-12 LRB 12" Rim
<b>Features</b>	<ul style="list-style-type: none"> <li>- P3 PULSE – Electronic feed control and rapid recovery auto-reverse and auto-stop clutch protection</li> <li>- Hydraulic fluid level site glass</li> <li>- Fuel level gauge</li> <li>- STOP—FORWARD—REVERSE—STOP – Feed roller control bar</li> <li>- Tool compartment</li> <li>- Highway LED trailer lights</li> <li>- Full flex 1800 lb ( 816 kg) torsion axle</li> <li>- Electric start, heavy duty battery</li> <li>- Latching feed table (closed position)</li> </ul>
<b>Options: Factory or after market dealer installed.</b>	<ul style="list-style-type: none"> <li>- Ladder hitch tongue accessory</li> <li>- Clean out tray kit accessory</li> </ul>

 **NOTE:** Specifications subject to change without notice.

## 7.1 Bolt Torque

### Checking Bolt Torque

The tables shown give correct torque values for various bolts and capscrews. Tighten all bolts to the torque values specified in the table, unless indicated otherwise. Check tightness of bolts periodically.

**IMPORTANT!** If replacing hardware, use fasteners of the same grade.

**IMPORTANT!** Torque figures indicated in the table are for non-greased or non-oiled threads. Do not grease or oil threads unless indicated otherwise. When using a thread locker, increase torque values by 5%.

 **NOTE:** Bolt grades are identified by their head markings.

Imperial Bolt Torque Specifications						
Bolt Diameter	Torque Value					
	SAE Gr. 2		SAE Gr. 5		SAE Gr. 8	
	lbf•ft	N•m	lbf•ft	N•m	lbf•ft	N•m
1/4"	6	8	9	12	12	17
5/16"	10	13	19	25	27	36
3/8"	20	27	33	45	45	63
7/16"	30	41	53	72	75	100
1/2"	45	61	80	110	115	155
9/16"	60	95	115	155	165	220
5/8"	95	128	160	215	220	305
3/4"	165	225	290	390	400	540
7/8"	170	230	420	570	650	880
1"	225	345	630	850	970	1320



Metric Bolt Torque Specifications				
Bolt Diameter	Torque Value			
	Gr. 8.8		Gr. 10.9	
	lbf•ft	N•m	lbf•ft	N•m
M3	0.4	0.5	1.3	1.8
M4	2.2	3	3.3	4.5
M6	7	10	11	15
M8	18	25	26	35
M10	37	50	52	70
M12	66	90	92	125
M14	83	112	116	158
M16	166	225	229	310
M20	321	435	450	610
M30	1,103	1 495	1,550	2 100

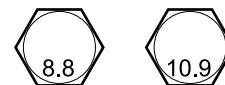

## 7.2 Hydraulic Fitting Torque

### Tightening Flare Type Tube Fittings

1. Check flare and flare seat for defects that might cause leakage.
2. Align tube with fitting before tightening.
3. Hand-tighten swivel nut until snug.
4. To prevent twisting the tube, use two wrenches. Place one wrench on the connector body and tighten the swivel nut with the second. Torque to values shown.

If a torque wrench is not available, use the FFFT (Flats From Finger Tight) method.

Hydraulic Fitting Torque					
Tube Size OD	Hex Size Across Flats	Torque value		Flats From Finger Tight	
		lbf•ft	N•m	Flats	Turns
3/16	7/16	6	8	2	1/6
1/4	9/16	11–12	15–17	2	1/6
5/16	5/8	14–16	19–22	2	1/6
3/8	11/16	20–22	27–30	1-1/4	1/6
1/2	7/8	44–48	59–65	1	1/6
5/8	1	50–58	68–79	1	1/6
3/4	1-1/4	79–88	107–119	1	1/8
1	1-5/8	117–125	158–170	1	1/8

Values shown are for non-lubricated connections.

## 7.3 Wheel Lug Torque

It is extremely important safety procedure to apply and maintain proper wheel mounting torque on your trailer axle. Torque wrenches are the best method to assure the proper amount of torque is being applied to a fastener.

**Wheel lugs should be torqued before first road use and after each wheel removal. Check and re torque after the first 10 miles (16 km), 25 miles (40 km), and again at 50 miles (80 km). Check periodically thereafter.**

**NOTE:** *Wheel lugs must be applied and maintained at the proper torque levels to prevent loose wheels, broken studs, and possible dangerous separation of wheels from your axle.*

Wheel Lug Nut Torque				
Wheel Size	Units	1st Stage	2nd Stage	3rd Stage
8"	lbf•ft N•m	12–20 16–26	30–35 39–45.5	45–55 58.5–71.5
12"	lbf•ft N•m	20–25 26–32.5	35–40 45.5–52	50–60 65–78
13"	lbf•ft N•m	20–25 26–32.5	35–40 45.5–52	50–60 65–78
14"	lbf•ft N•m	20–25 26–32.5	50–60 65–78	90–120 117–156
15"	lbf•ft N•m	20–25 26–32.5	50–60 65–78	90–120 117–156
16"	lbf•ft N•m	20–25 26–32.5	50–60 65–78	90–120 117–156

Wheel Lug Torque Pattern

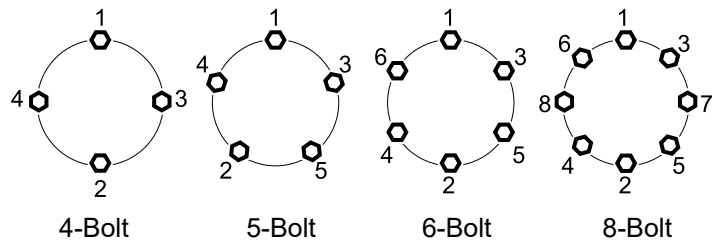

- Start all lugs by hand to prevent cross threading.
- Tighten lugs in sequence, per wheel lug torque sequence chart.
- The tightening of the fasteners should be done in stages. Following the recommended sequence, tighten fasteners per wheel torque requirements chart.

## 8. Product Warranty



### LIMITED WARRANTY

Wallenstein products are warranted to be free of defects in materials and workmanship under normal use and service, for a period of

**Five Years for Consumer Use**

**Two Years for Commercial/Rental Use**

from the date of purchase, when operated and maintained in accordance with the operating and maintenance instructions supplied with the unit. Warranty is limited to the repair of the product and/or replacement of parts.

This warranty is extended only to the original purchaser and is not transferable.

Repairs must be done by an authorized dealer. Products will be returned to the dealer at the customer's expense. Include the original purchase receipt with any claim.

**This warranty does not cover the following:**

- 1) Normal maintenance or adjustments
- 2) Normal replacement of wearable and service parts
- 3) Consequential damage, indirect damage, or loss of profits
- 4) Damages resulting from:
  - Misuse, negligence, accident, theft or fire
  - Use of improper or insufficient fuel, fluids or lubricants
  - Use of parts or aftermarket accessories other than genuine Wallenstein parts
  - Modifications, alteration, tampering or improper repair performed by parties other than an authorized dealer
  - Any device or accessories installed by parties other than an authorized dealer
- 5) Engines. Engines are covered by the manufacturer of the engine for the warranty period they specify. For the details of your engine warranty, see your engine owner's manual. Information about engine warranty and service is also available in the FAQ section at [www.wallensteinequipment.com](http://www.wallensteinequipment.com)

# 9. Alphabetical Index

<b>A</b>		<b>H</b>	
Accessories		Hood Deflector .....	22
Clean-out Tray .....	32	Hydraulic Circuit Diagram .....	47
Ladder Hitch Kit .....	32	Hydraulic Fitting Torque .....	61
<b>B</b>		Hydraulic Oil .....	43
Bolt torque .....	60	Hydraulic Oil Level Check .....	35
Break-in .....	34	Hydraulic Oil Tank Capacity .....	48
BXTR5224 Hydraulic Circuit .....	47	<b>I</b>	
<b>C</b>		Introduction .....	2
Checking Bolt Torque .....	60	<b>J</b>	
Chipper Severely Plugged .....	40	Jump Starting .....	50
Chipping Operation .....	38	<b>L</b>	
Chipper Severely Plugged .....	40	Ladder Hitch Kit .....	32
Unplugging the Chipper .....	39	Ledger Knife – Changing .....	55
Choke Knob .....	21	Ledger Knife – Checking .....	54
Clean-out Tray .....	32	Lubricants .....	43
Control Bar Stop Positions .....	23	<b>M</b>	
Controls .....	21	Machine Break-In .....	34
Clean-out Tray .....	32	Machine Components .....	20
Discharge Chute .....	22	Machine Set-up .....	36
Engine Controls .....	21	Maintenance Decals .....	6
Choke Knob .....	21	Maintenance Schedule .....	44
Engine Start Switch .....	22	<b>O</b>	
Throttle Lever .....	21	Oil Level Alert .....	22
Feed Roller Control .....	23	Operating Instructions .....	33
Hood Deflector .....	22	Before Startup .....	33
Ladder Hitch Kit .....	32	Chipping Operation .....	38
<b>D</b>		Engine Oil Level Check .....	35
Discharge Chute Operation .....	22	Fuel Level Check .....	34
<b>E</b>		Hydraulic Oil Level Check .....	35
Engine .....	43	Machine Break-In .....	34
Engine Air Cleaner .....	49	Machine Setup .....	36
Engine Controls .....	21	P3 PULSE Electronic Control System .....	25
Engine Fuel .....	43	Pre-operation Checklist .....	33
Engine Hours .....	22	Starting the Engine .....	37
Engine Oil .....	43	Stopping in an Emergency .....	37
Engine Oil Level Check .....	35	Stopping Procedure .....	37
Engine Start Switch .....	22	Storage .....	42
Equipment Safety Guidelines .....	8	Transporting .....	41
<b>F</b>		Unplugging the Chipper .....	39
Familiarization .....	19	Operating Safety .....	9
Job Site Familiarization .....	19	Operator Orientation .....	19
Operator Orientation .....	19	<b>P</b>	
To the New Operator .....	19	P3 PULSE Electronic Control System .....	25
Feed Roller Control .....	23	Diagnostics screen .....	30
Fluids .....	43	Enter Password .....	31
Foreword		Feed Settings screen .....	28
Delivery Inspection Report .....	4	Machine Select screen .....	31
Fuel Level – Checking .....	34	Main screen .....	27
<b>G</b>		Menus .....	27
Gas Motor Safety .....	11	Overview .....	25
Grease .....	43	Programming Hints .....	29
Grease Points .....	45	Reset Defaults screen .....	30
		Settings screen .....	28

Start-up Screen.....	25
User Interface.....	26
Personal Protective Equipment (PPE).....	8
Pre-Operation Checklist.....	33
Pump Drive Belt Tension.....	51

## R

Refueling.....	34
Replacing Damaged Safety Signs.....	18
Rotor Blades – Changing.....	53
Rotor Drive Belt Replacement.....	52
Rotor Drive Belt Tension.....	52

## S

Safe Condition.....	8, 43
Safety.....	7
Battery Safety.....	10
Equipment Safety Guidelines.....	8
Gas Motor Safety.....	11
Hydraulic Safety.....	11
Operating Safety.....	9
Personal Protective Equipment (PPE).....	8
Preparation.....	9
Refueling Safety.....	10
Safety Alert Symbol.....	7
Safety Training.....	8
Signal Words.....	7
Tire Safety.....	10
Transport Safety.....	10
Safety Alert Symbol.....	7
Safety Notice Decals.....	6
Safety Signs.....	
Safety Sign Locations.....	14
Safety Training.....	8
Serial number.....	5
Service and Maintenance.....	43
Electrical System.....	56
Fuel Filter – Changing.....	56
Hydraulic Oil – Changing.....	48
Clean Suction Strainer.....	48
Hydraulic Oil Filter - Changing.....	49
Hydraulic Pump Drive Belt Replacement.....	51
Pump Drive Belt Tension.....	51
Ledger Knife – Changing.....	55
Ledger Knife – Checking.....	54
Ledger Knife Clearance.....	54
Maintenance Safety.....	43
Rotor Blades – Changing.....	53
Rotor Drive Belt Replacement.....	52
Rotor Drive Belt Tension.....	52
Servicing the Battery.....	50
Cleaning the Battery.....	50
Installing the Battery.....	50
Jump Starting.....	50
Removing the Battery.....	50
Sheave Alignment.....	52
Twig Breaker.....	55
Upper Feed Roller Tension Adjustment.....	53
Welding on the Machine.....	56
Sheave Alignment.....	52
Sign-off form.....	13
Specifications.....	59
Starting the Engine.....	37
Stopping in an Emergency.....	37
Stopping Procedure.....	37

Storage.....	42
Placing Chipper in Storage.....	42

## T

Throttle Lever.....	21
Transporting.....	41
Troubleshooting Guide.....	57
Twig Breaker.....	55
Types of Decals on the Machine.....	6
Types of Product Decals.....	6

## U

Understanding Safety Decals.....	14
Unplugging.....	39
Upper Feed Roller Tension Adjustment.....	53

## W

Welding on the machine.....	56
Wheel Lug Torque.....	61





A series of horizontal lines for writing, starting from the top of the page and extending downwards. The lines are evenly spaced and cover most of the page's width.



A series of horizontal lines for writing. The first two lines are positioned to the right of the notepad icon. Below these, there are 20 additional horizontal lines spaced evenly down the page, providing a template for handwriting practice.



A series of horizontal lines for writing, starting with a double-line header and followed by 24 single-line rows.

**WALLENSTEIN**