

# Set-up Instructions

---

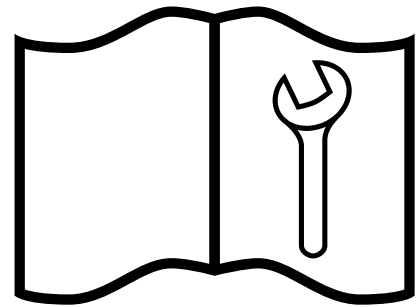

**MX80G**

**MX50G**

**MX80P**

**MX50P**

**MX25**

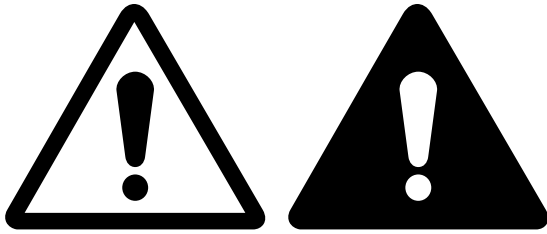

---

**IMPORTANT!** Inspect for damage from shipping. Immediately contact the shipping company if damage is found.

---

*Note:* Some parts are attached to skid with screws.  
Shipping brackets are not reused.

## Always Put Safety First!

Read these assembly instructions thoroughly before beginning. Make sure each step is understood before attempting it. Be familiar with all safety signs on the machine and their meaning.

Tighten all fasteners to the torque value specified on the last page. Recheck before using the machine.

### **WARNING!**

Position the crate in a large open area to allow access from all sides during assembly.

Stay clear of overhead power lines and obstructions when lifting the machine during assembly. Contact with power lines can cause electrocution. Contact with obstructions can damage components or cause them to fail.

Keep the assembly area clean to prevent slipping or tripping.

Use a hoist when lifting components that weigh 50 lb (23 kg) or more to avoid back injury.

All lifting devices (straps, slings, chains, ratchet blocks) must comply with applicable local regulations and certifications. Wallenstein Equipment Inc. cannot accept responsibility for the use of sub-standard equipment and work practices.

Use lifting equipment with a capacity greater than the weight of the component. Place jack stands or wood blocking under the machine to securely stabilize it before working on it during assembly.

Use the correct tool for the job. Repair or replace broken or defective equipment or tools. Makeshift tools can create safety hazards. A tool that breaks or slips during use risks personal injury.

### **WARNING!**

Avoid the risk of personal injury or machine damage! Read the operator's manual before using this equipment. Carefully read all safety messages in the manual and follow all safety signs on the machine.

---

Assembly hardware is located inside operator's manual tube.

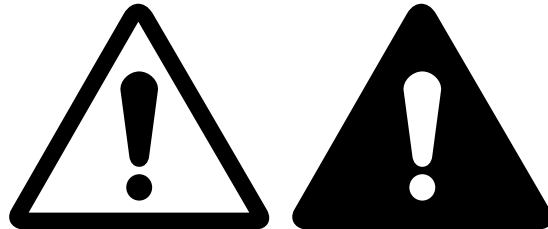

## Always Put Safety First!

Read these assembly instructions thoroughly before beginning. Make sure each step is understood before attempting it. Be familiar with all safety signs on the machine and their meaning.

Tighten all fasteners to the torque value specified on the last page. Recheck before using the machine.

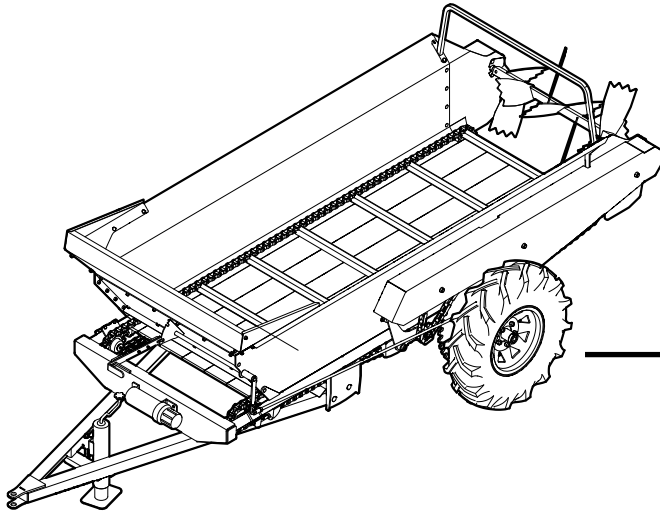

MX80G

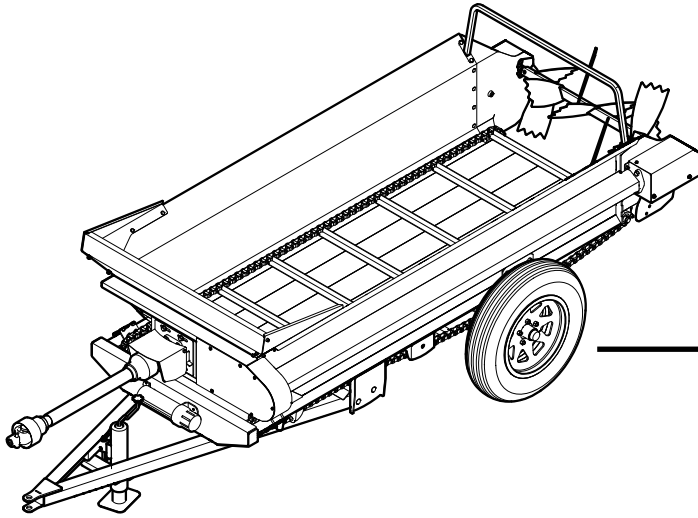

MX50G

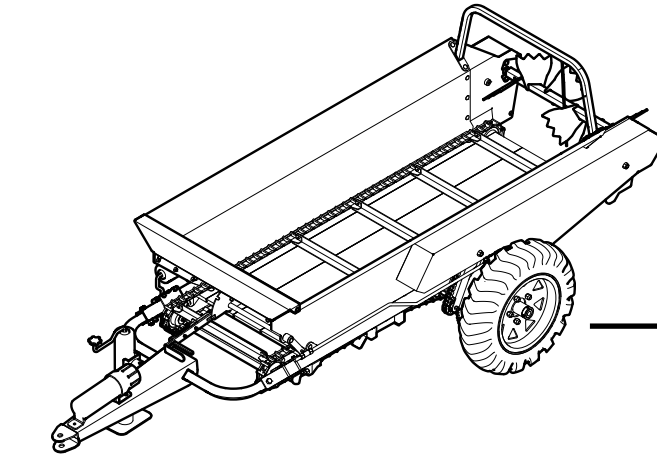

MX80P

MX50P

MX25

1

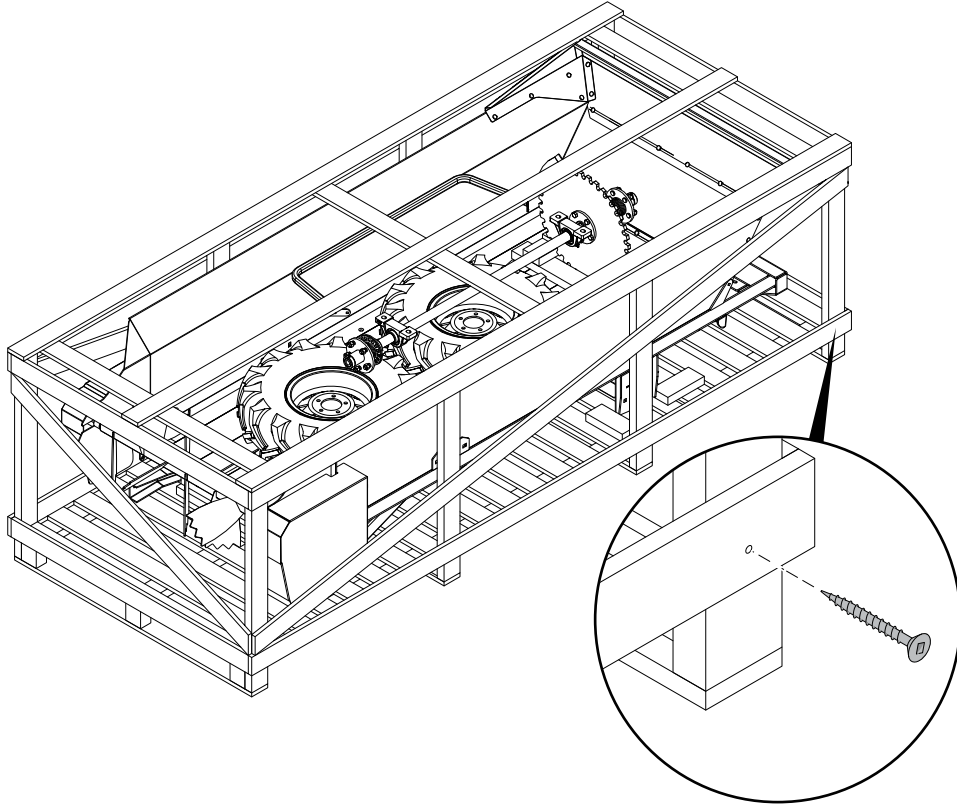

MX80G  
MX50G

2

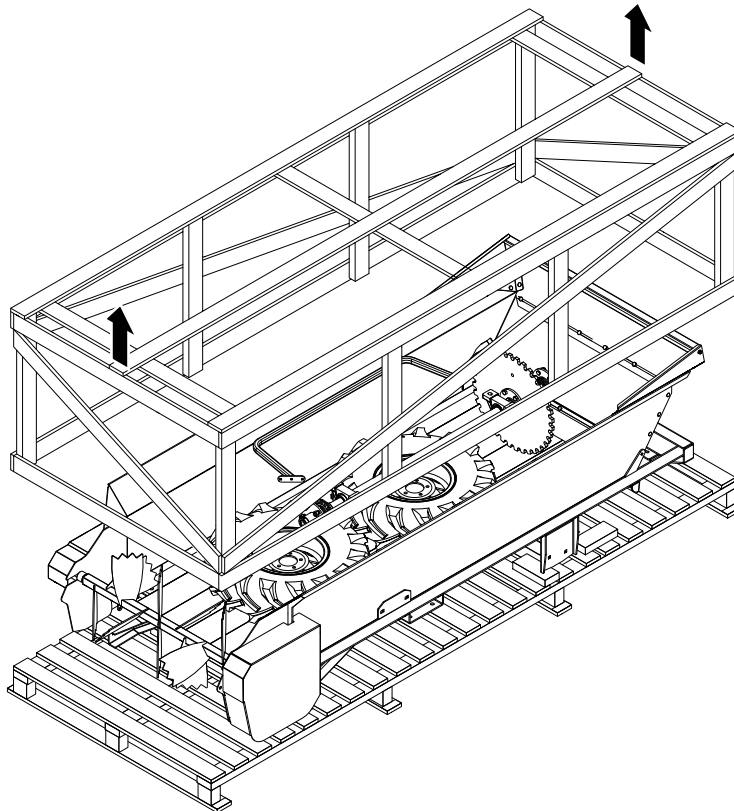

3

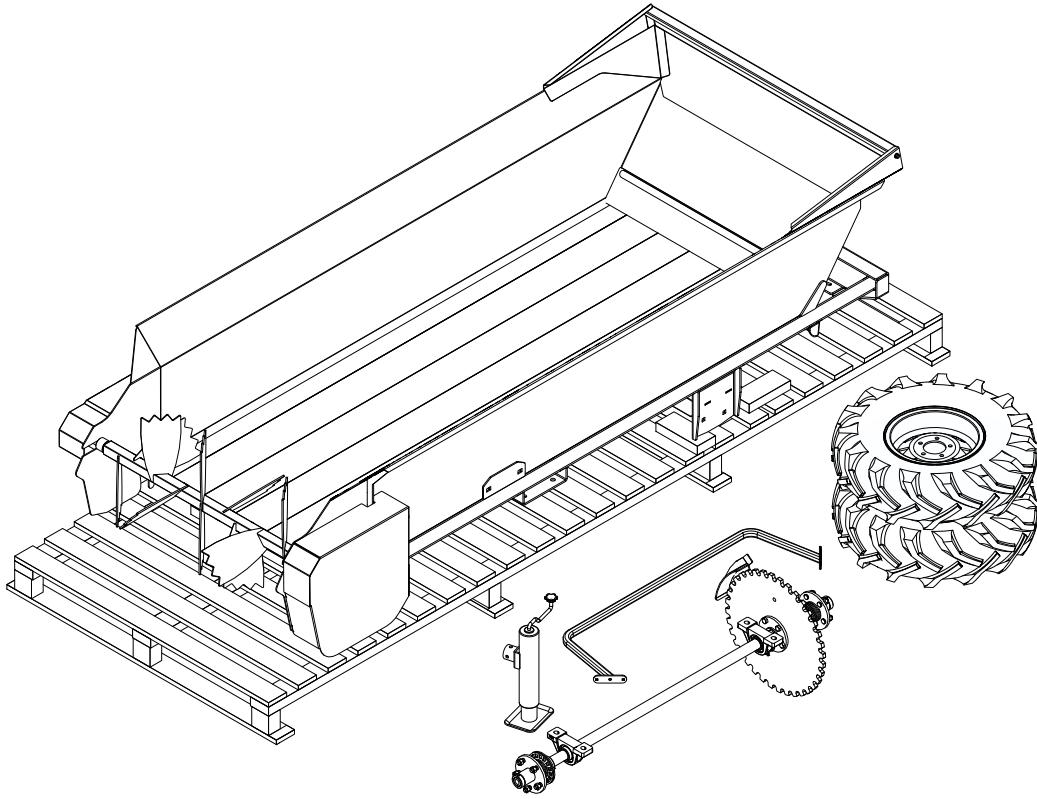

MX80G  
MX50G

4

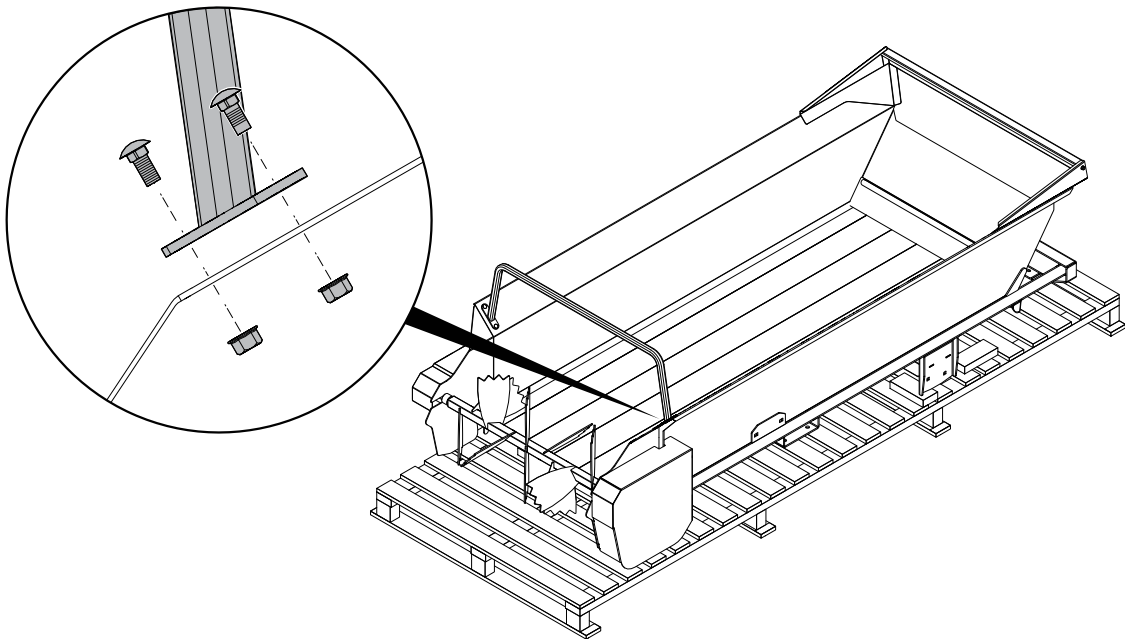

5

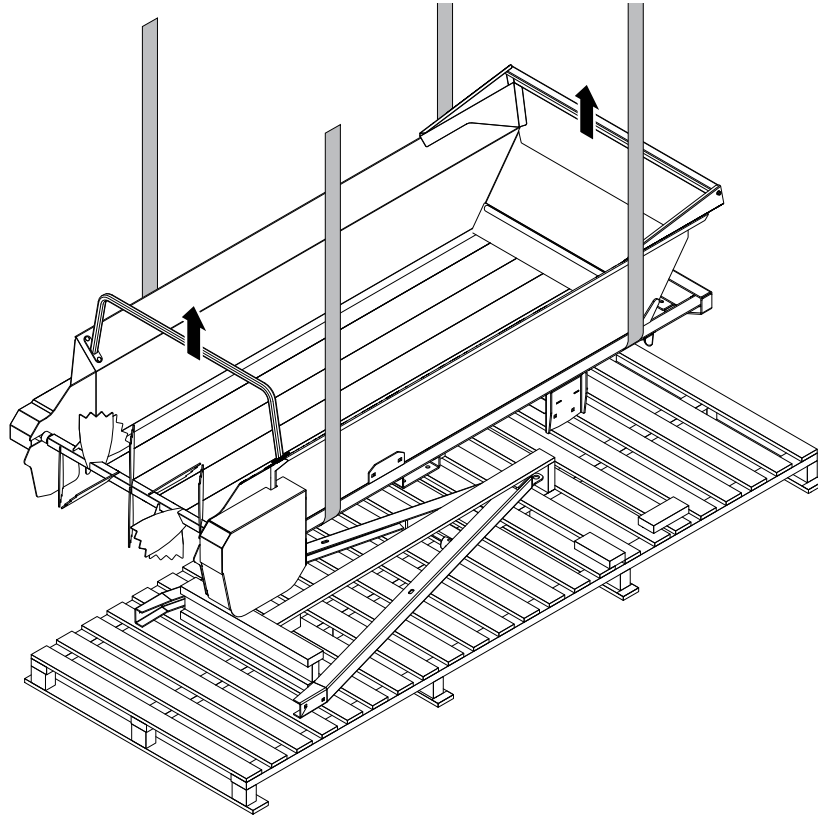

MX80G  
MX50G

6

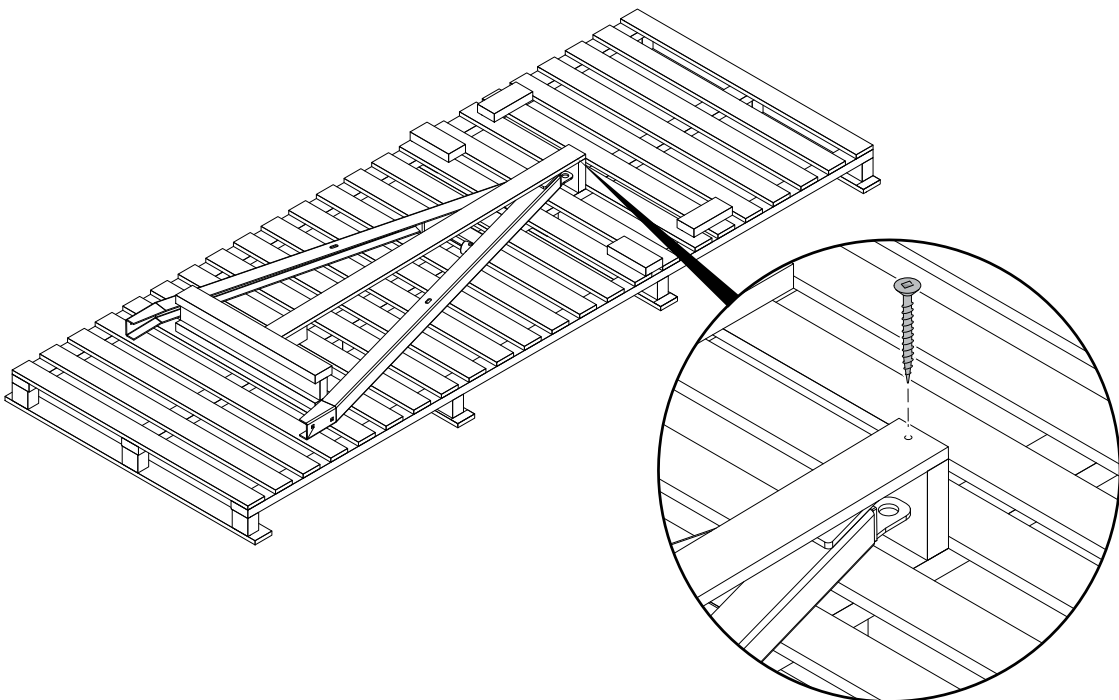

7

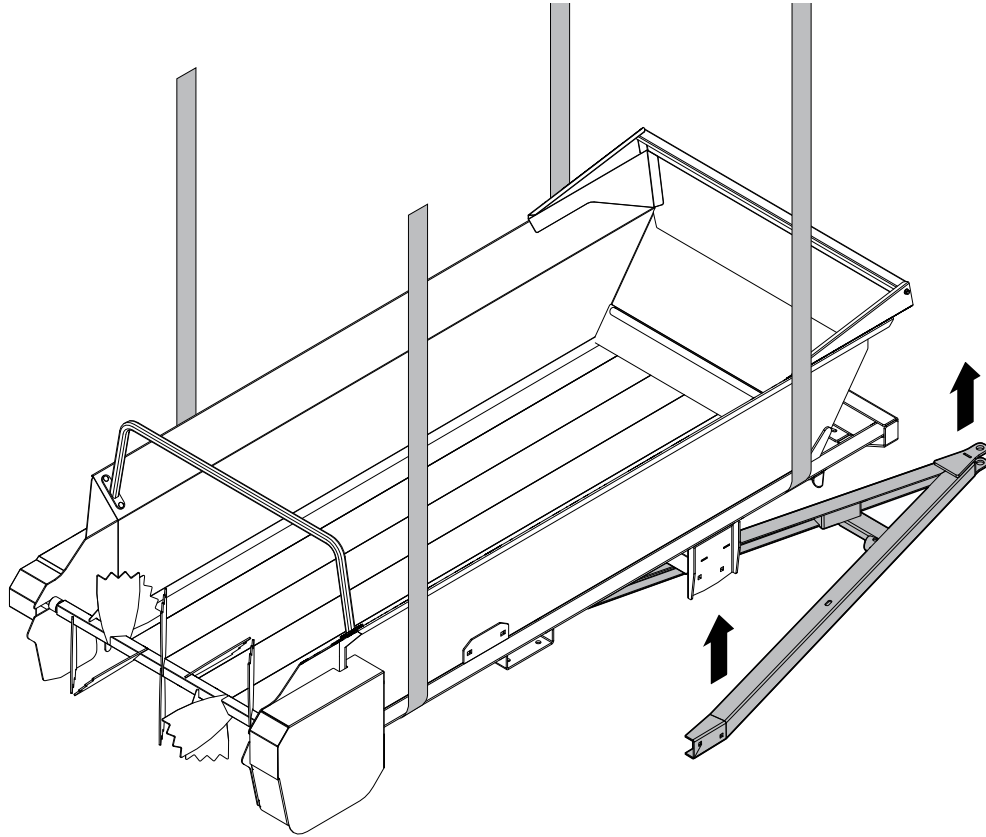

MX80G  
MX50G

8

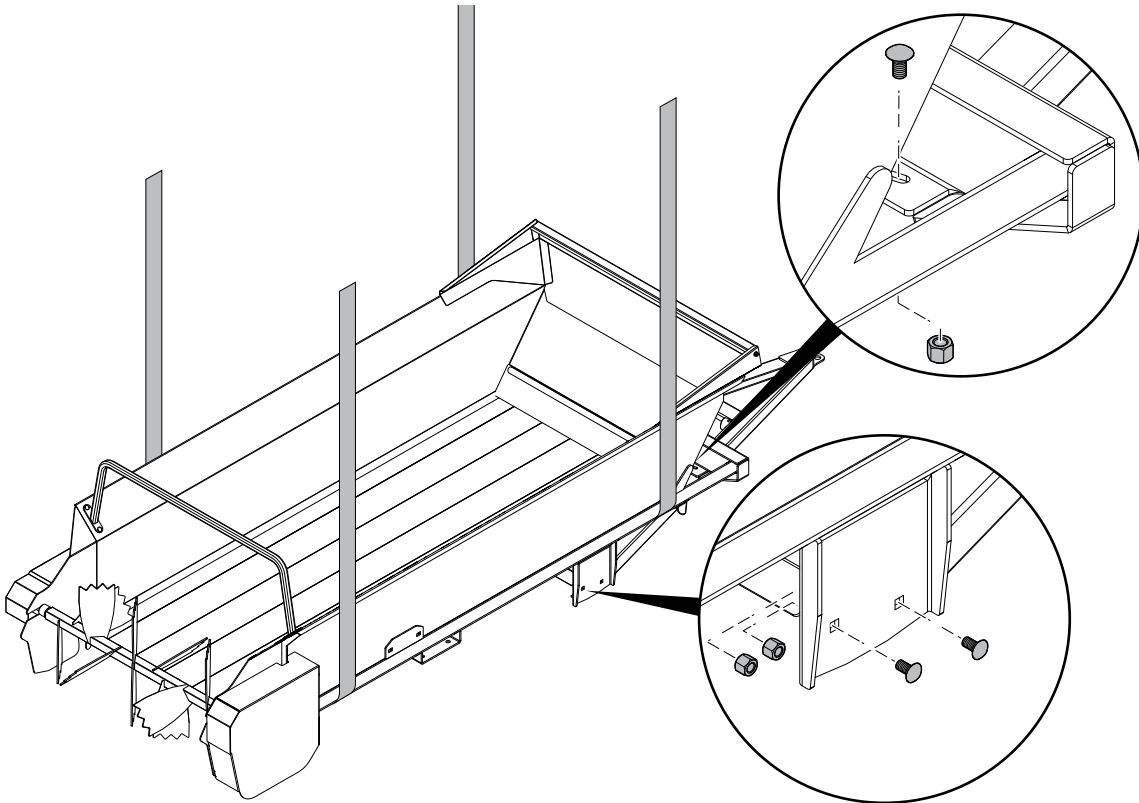

9

MX80G  
MX50G

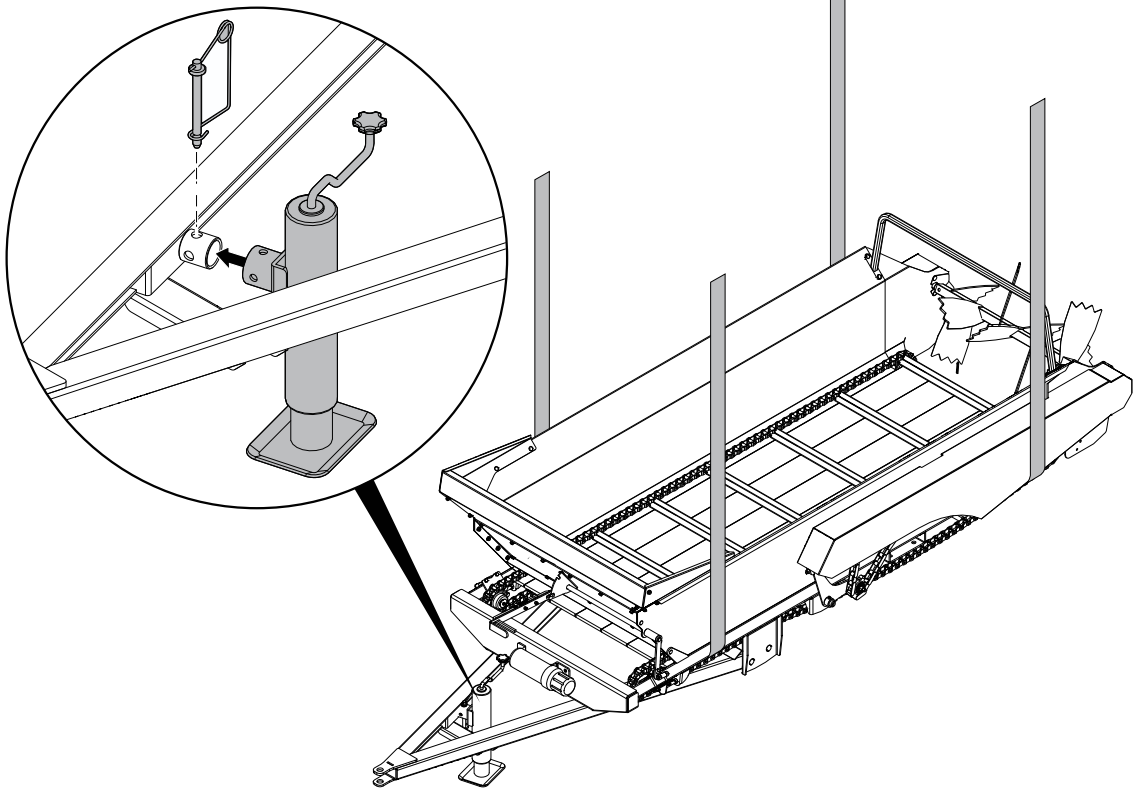

10

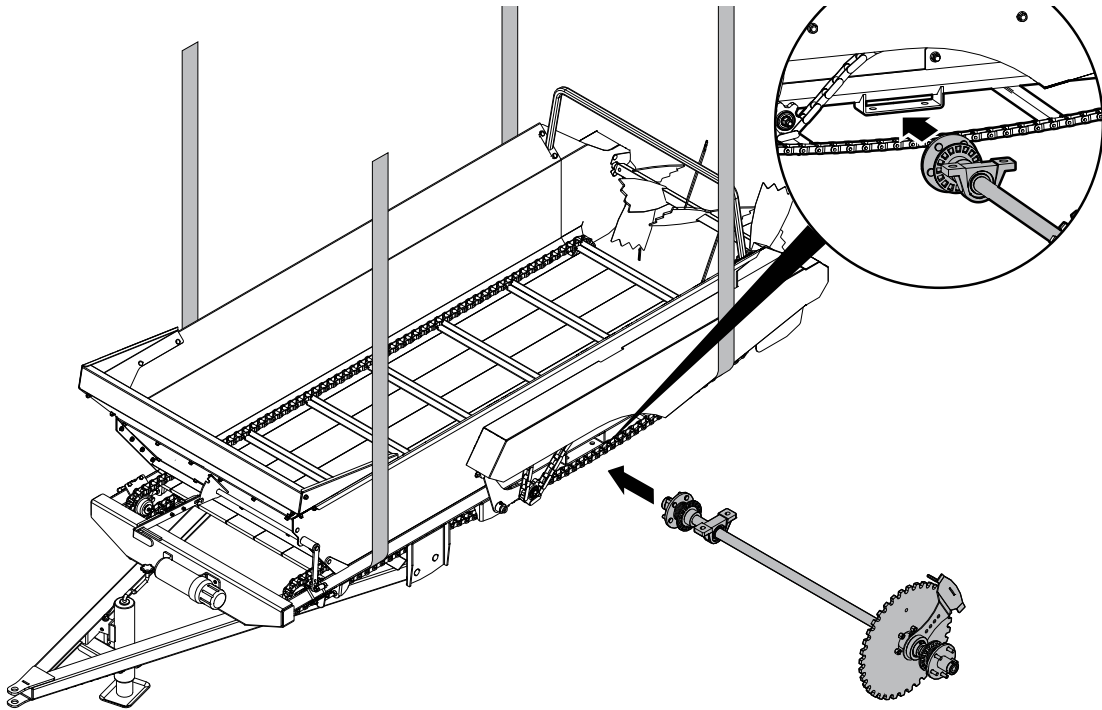



11

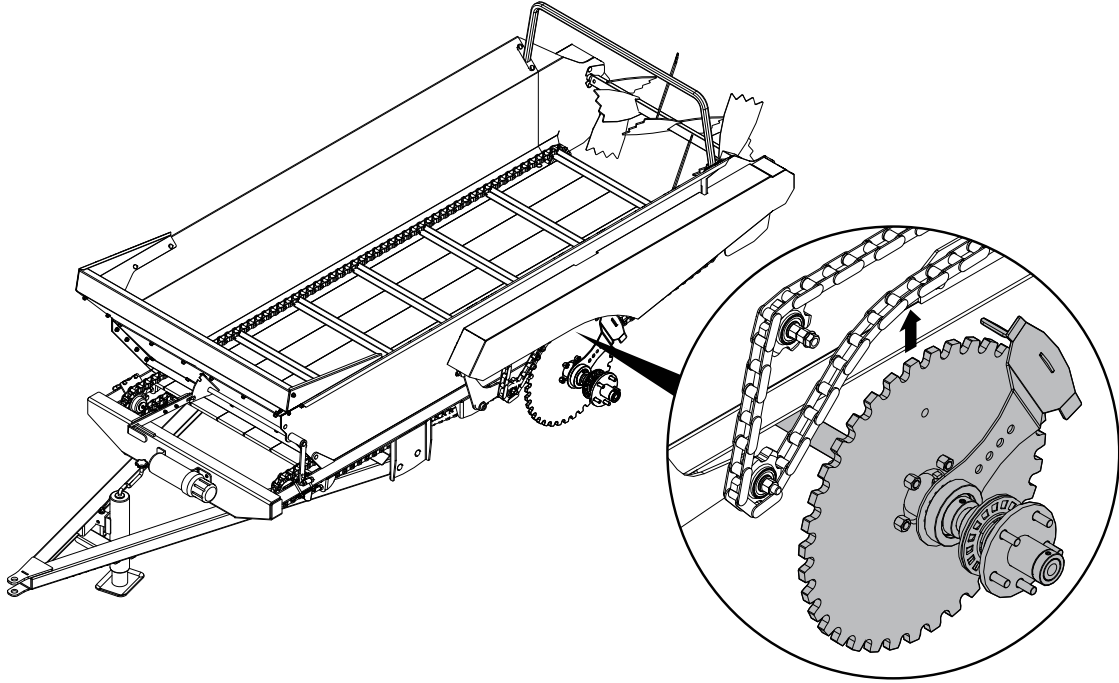

MX80G  
MX50G

12

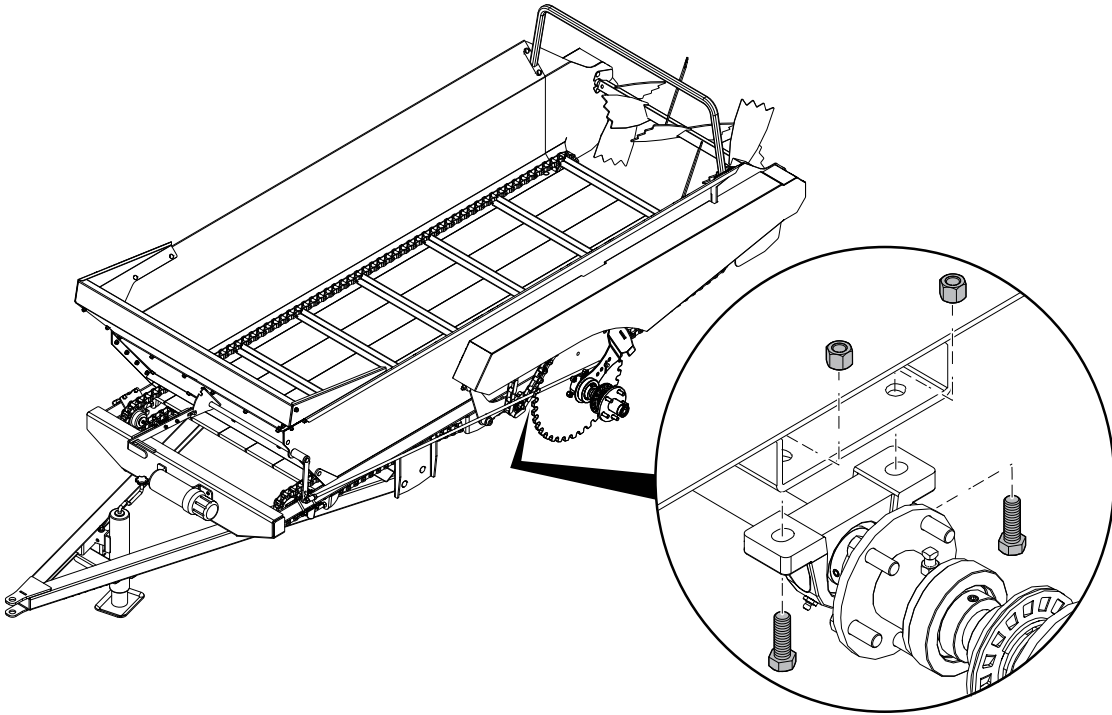

13

MX80G  
MX50G

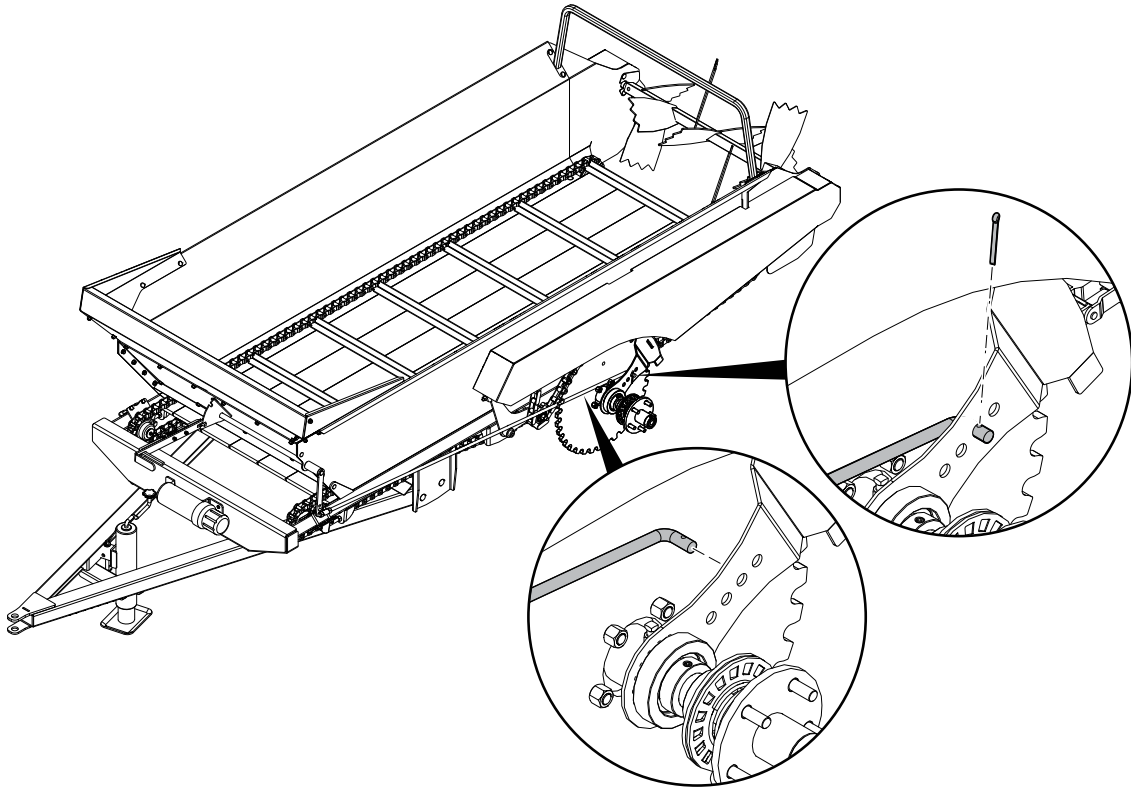

14

	
lbf·ft	80
N·m	110

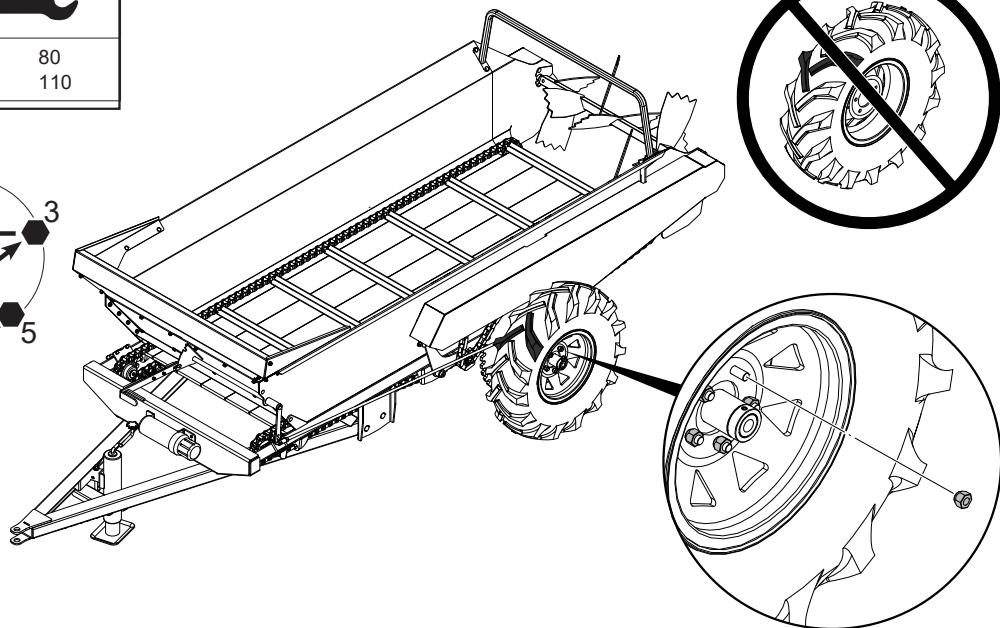
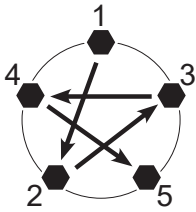

1

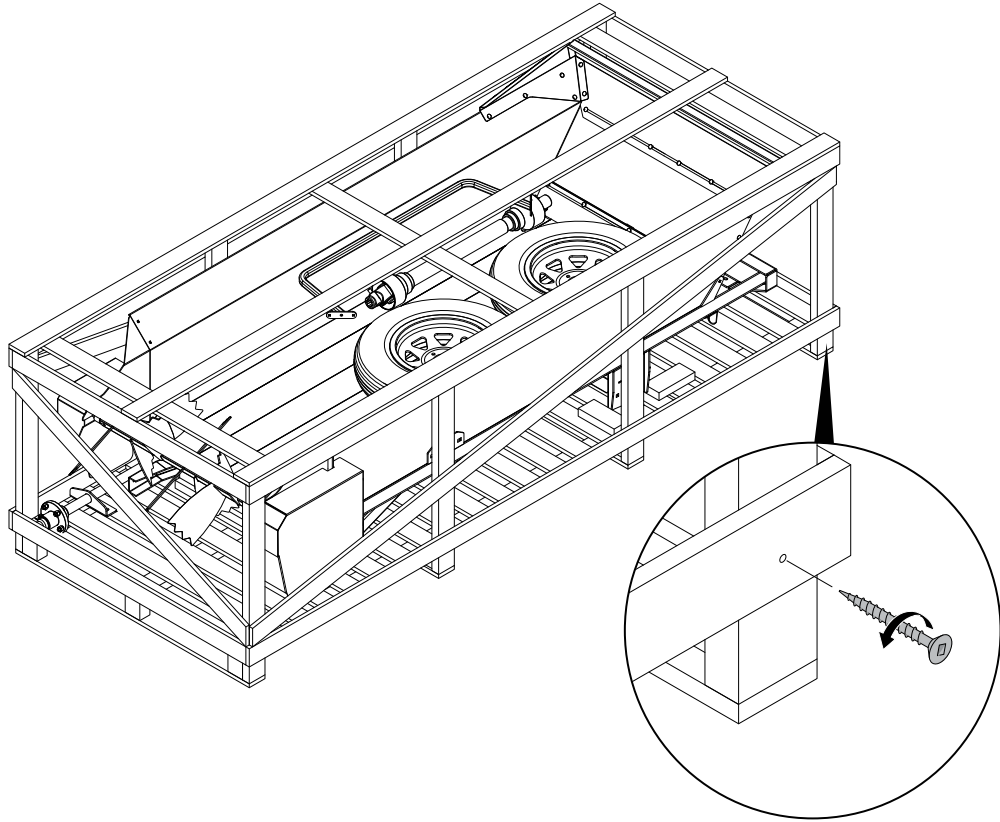

MX80P  
MX50P

2

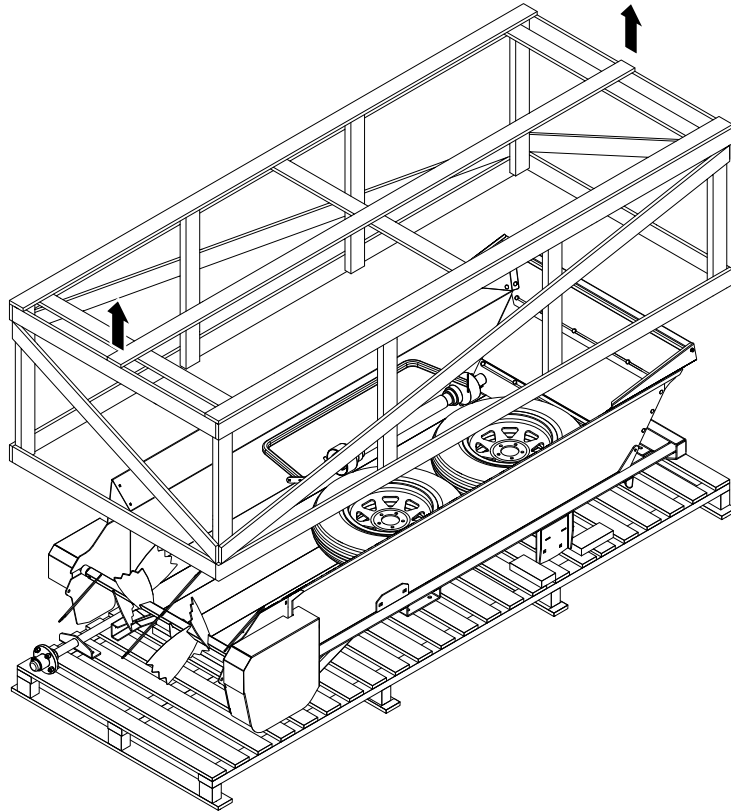

3

MX80P  
MX50P

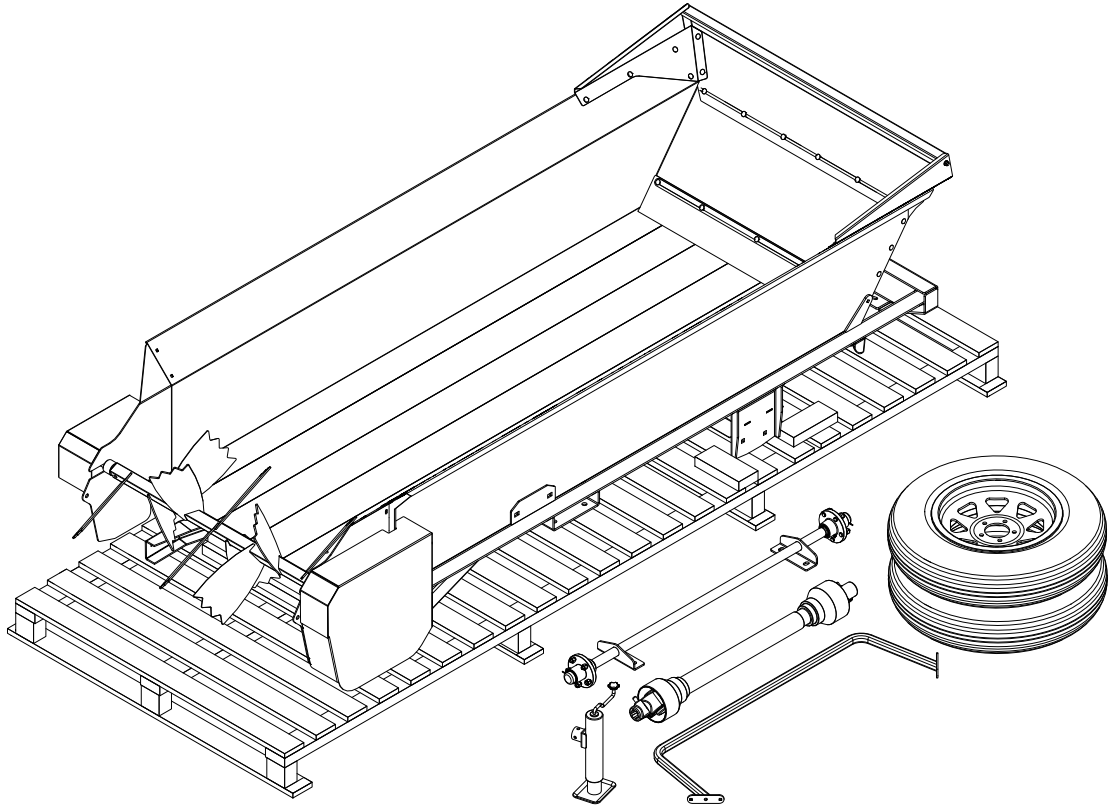

4

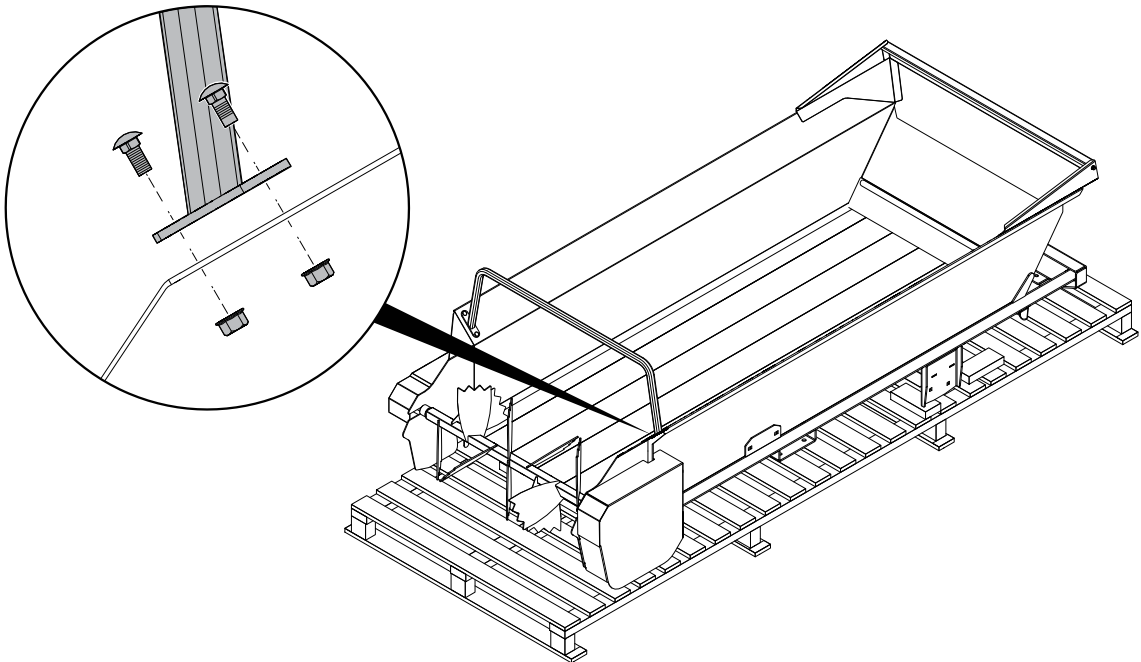

5

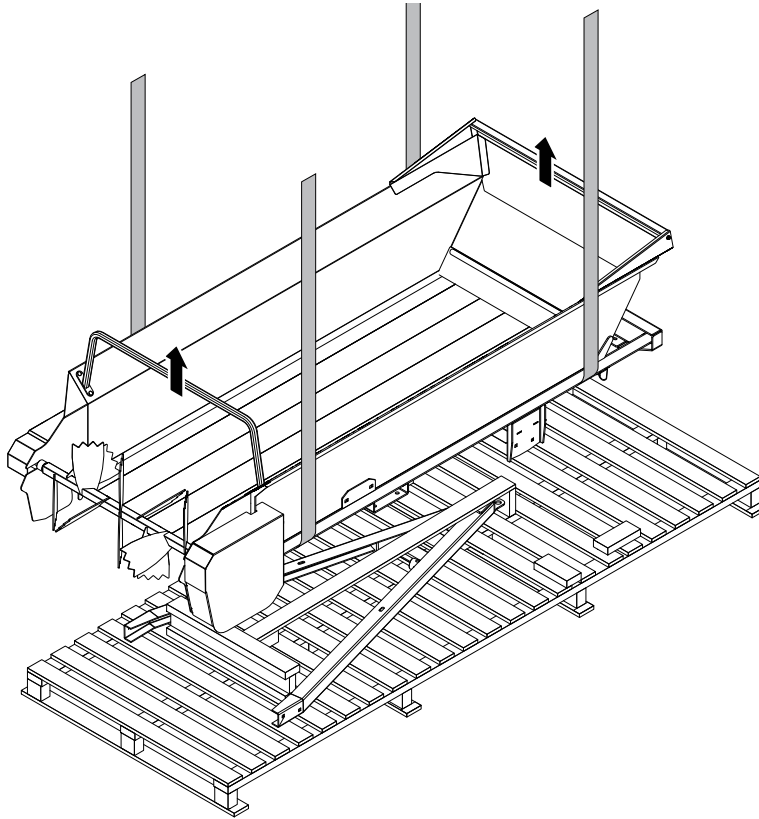

MX80P  
MX50P

6

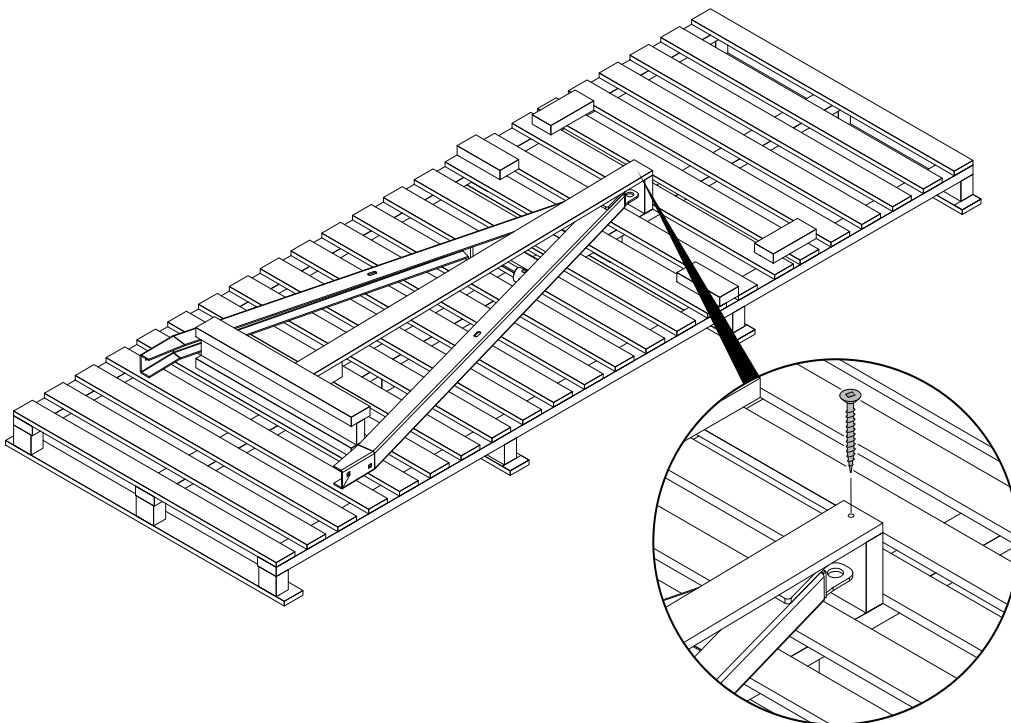

7

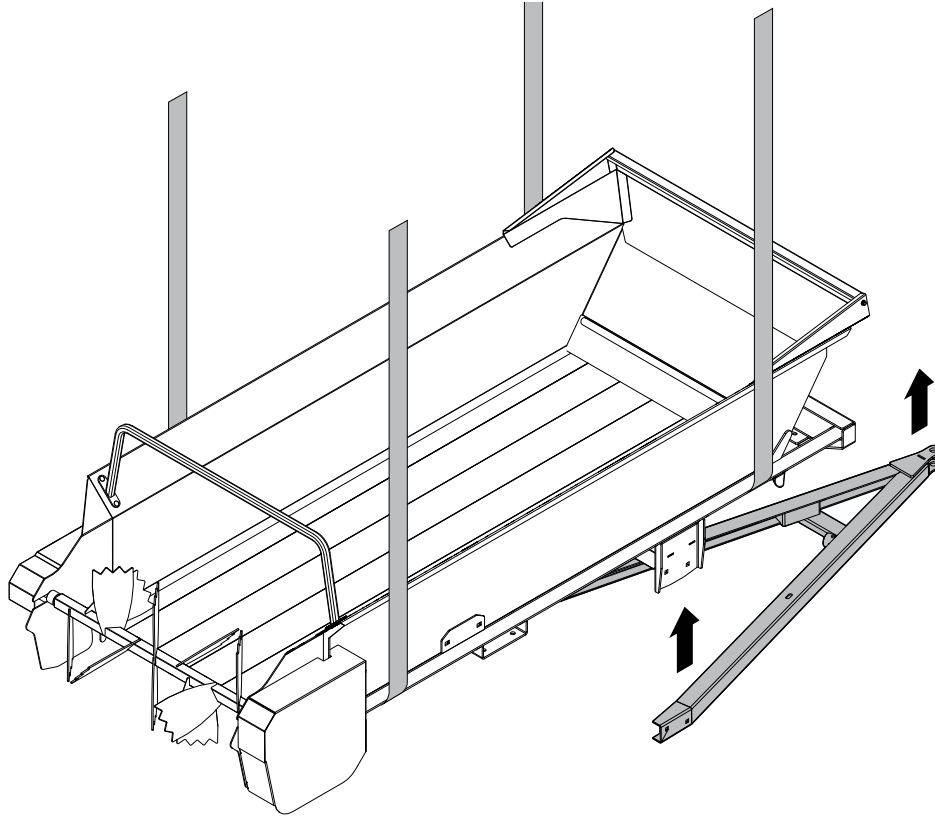

MX80P  
MX50P

8

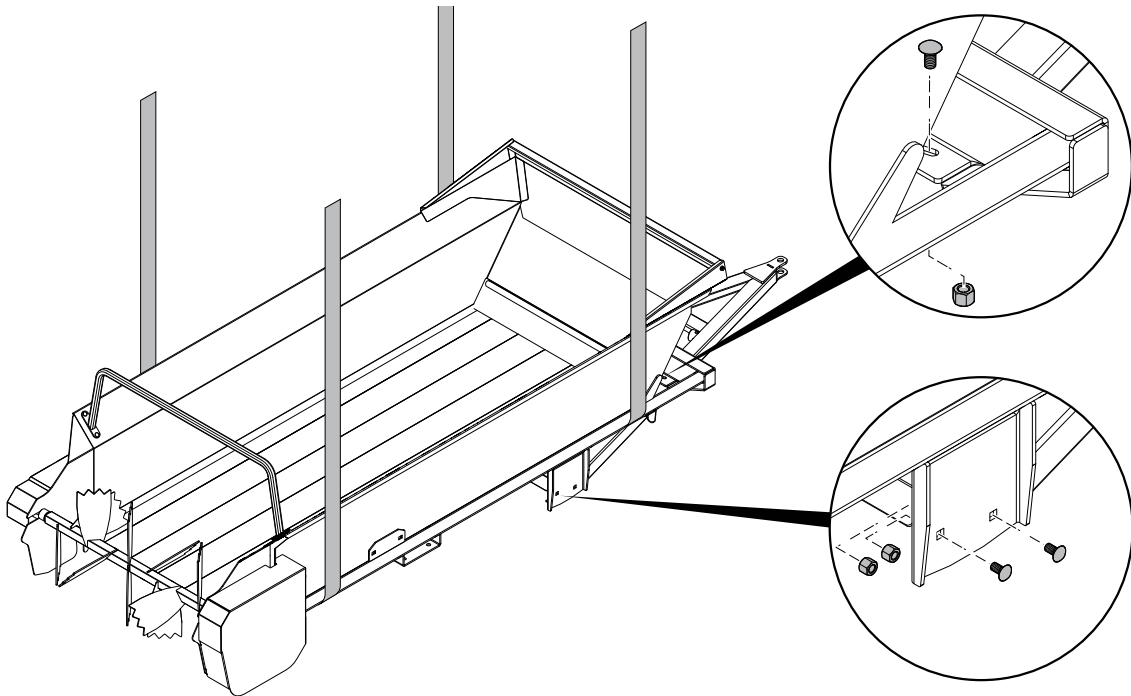

9

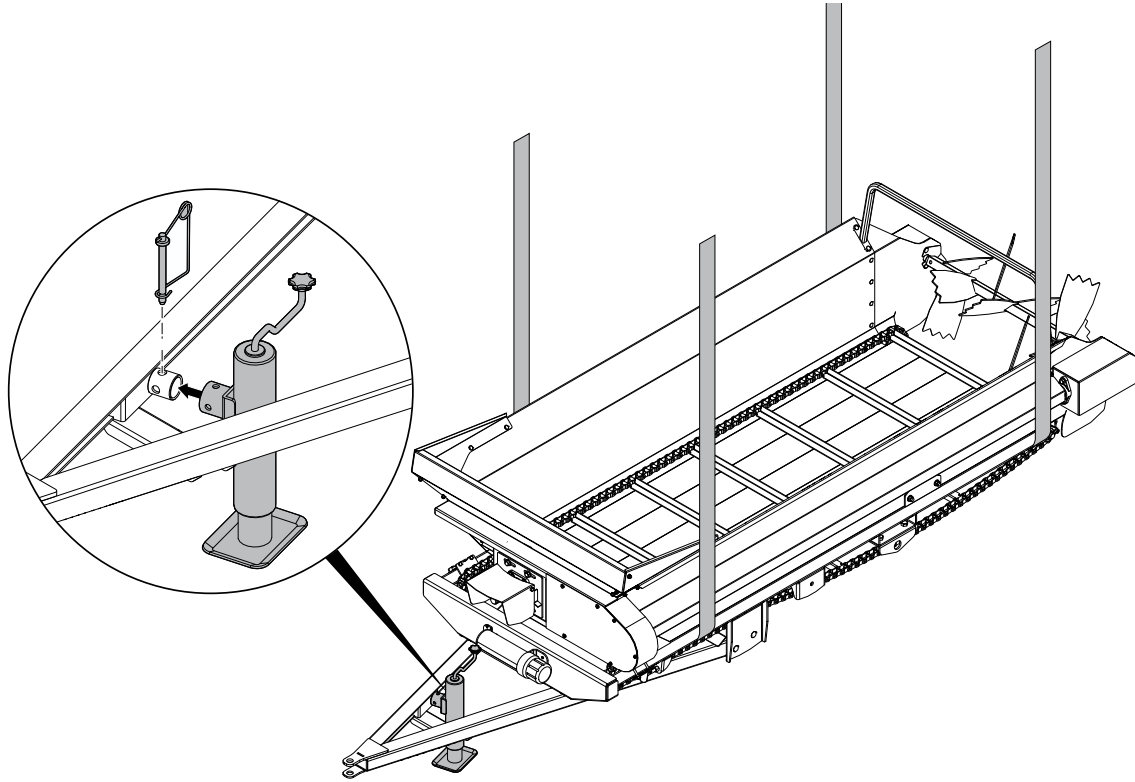

MX80P  
MX50P

10

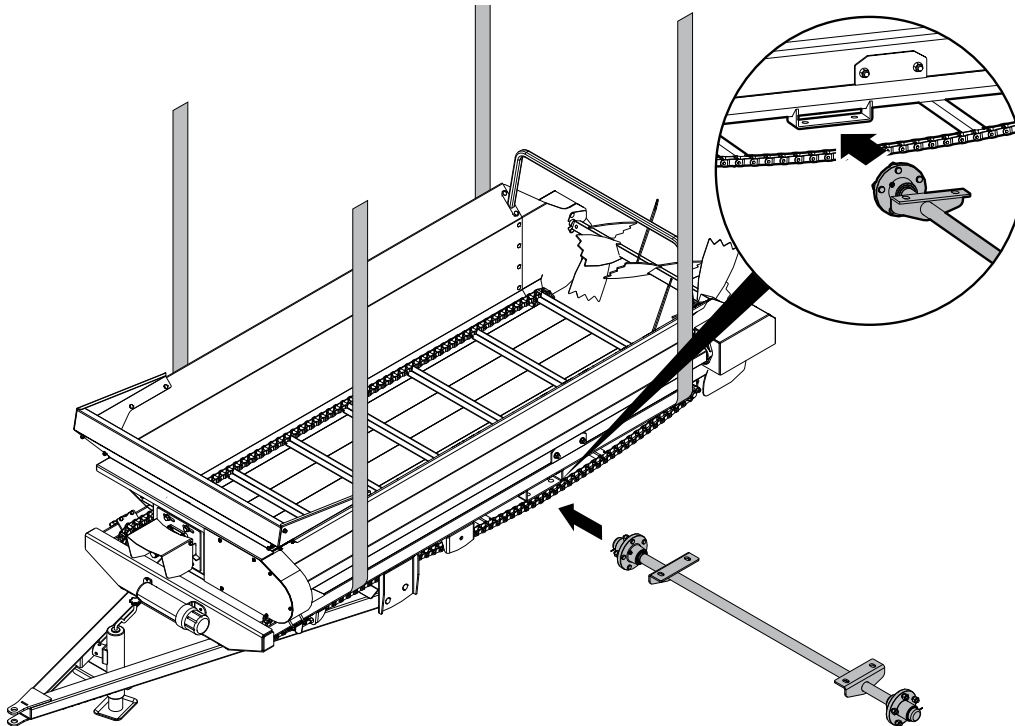

11

MX80P  
MX50P

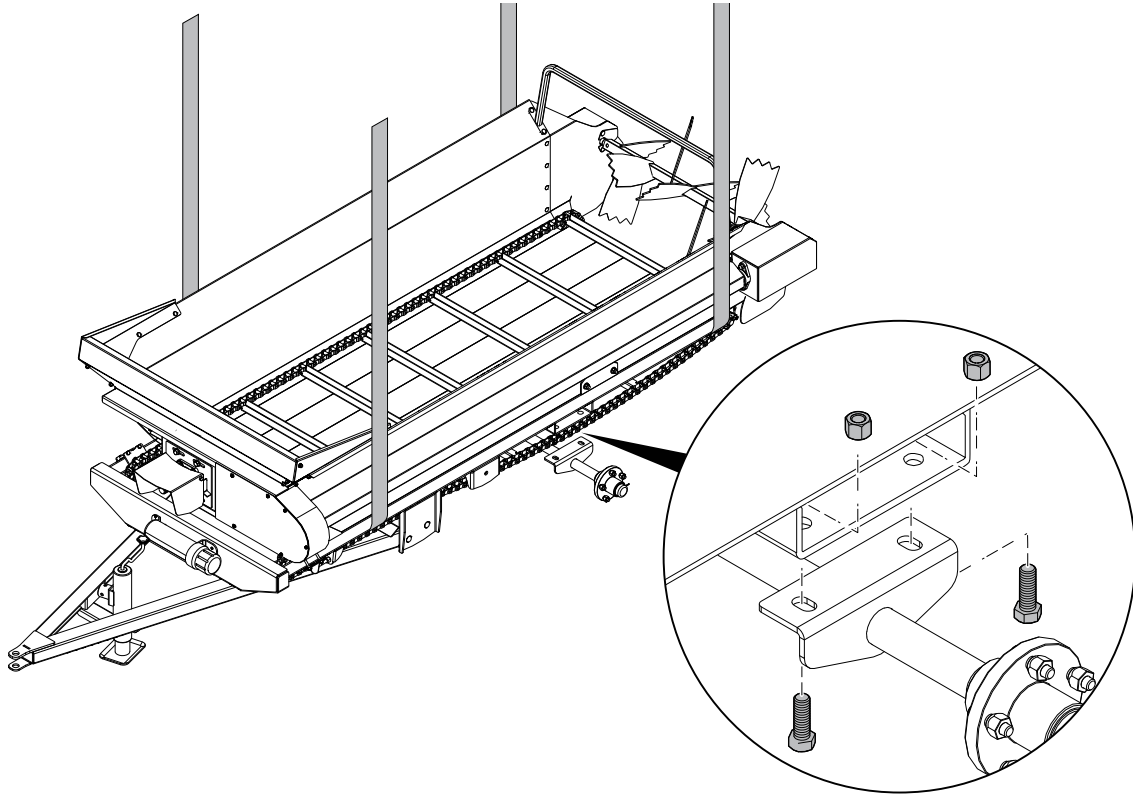

12

	
lb•ft	80
N•m	110

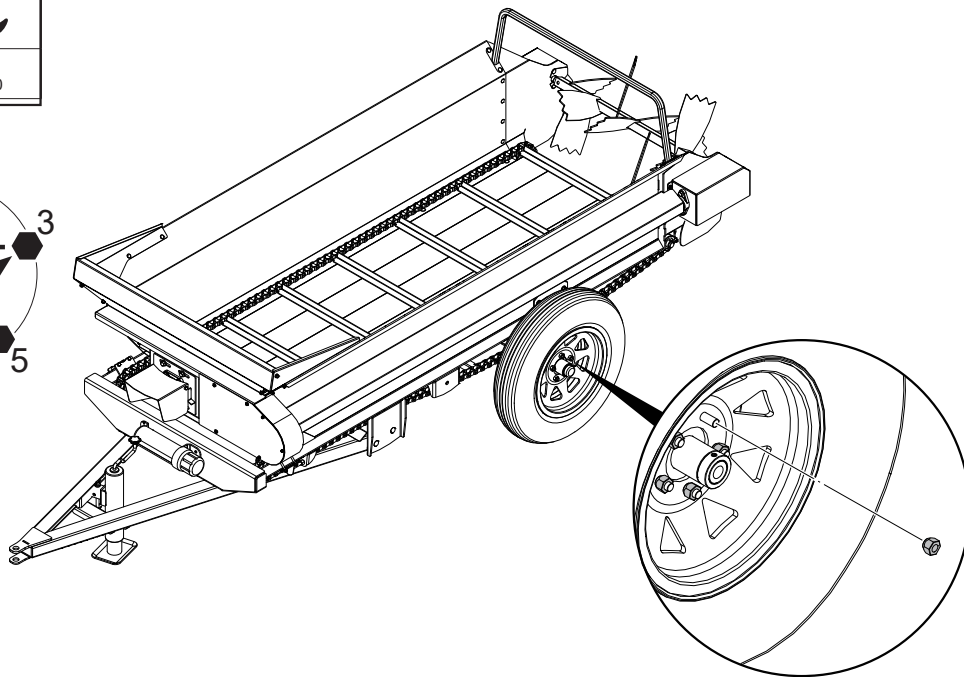
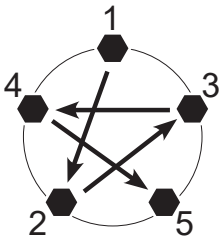



1

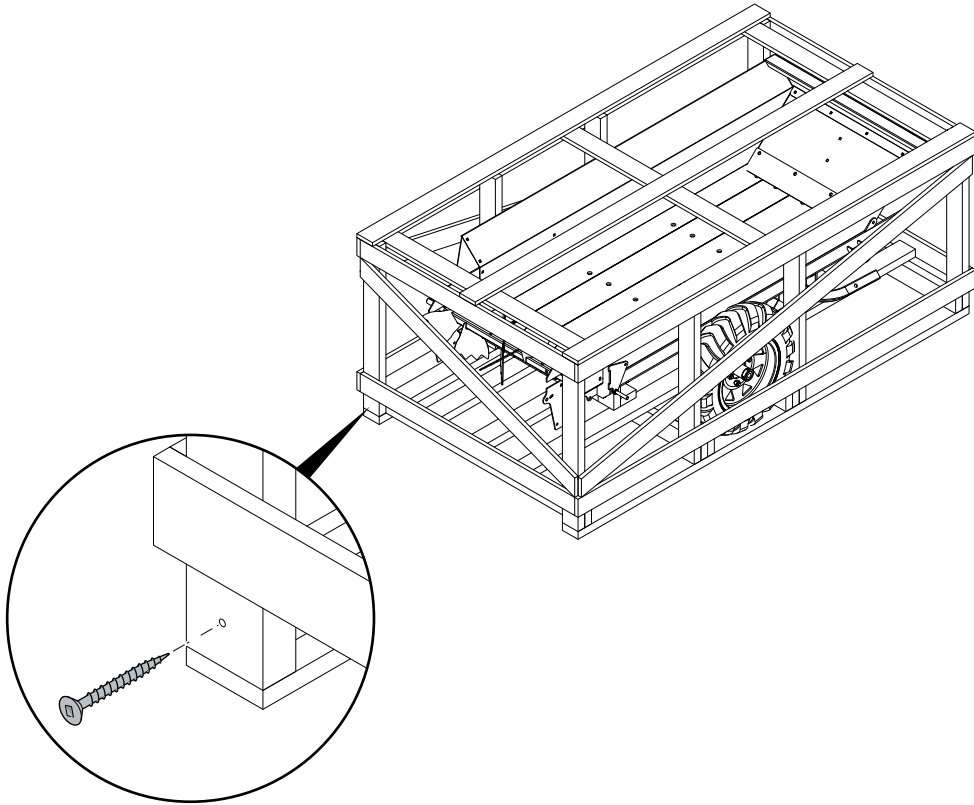

2

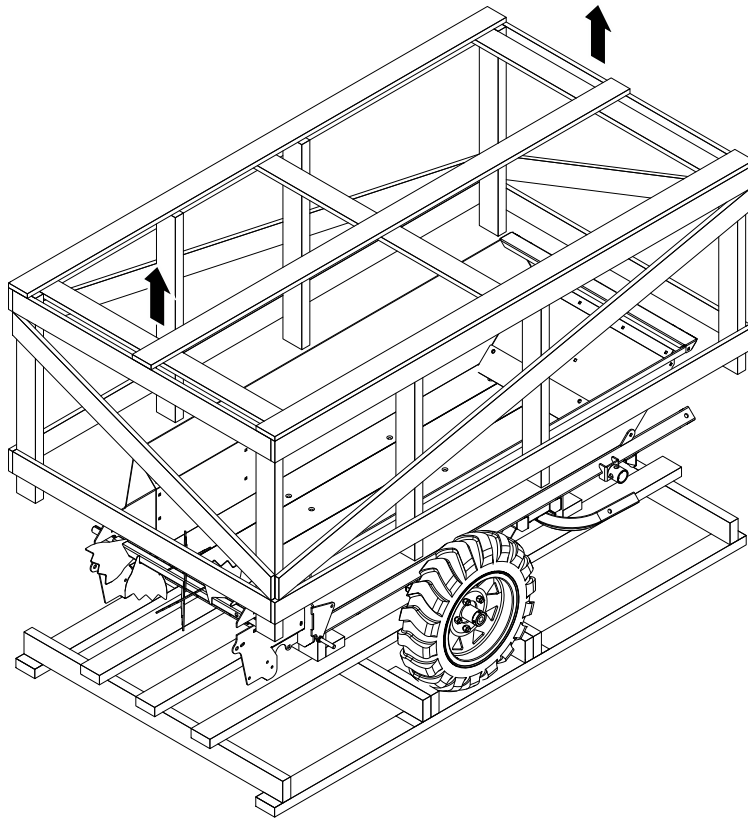

MX25

3

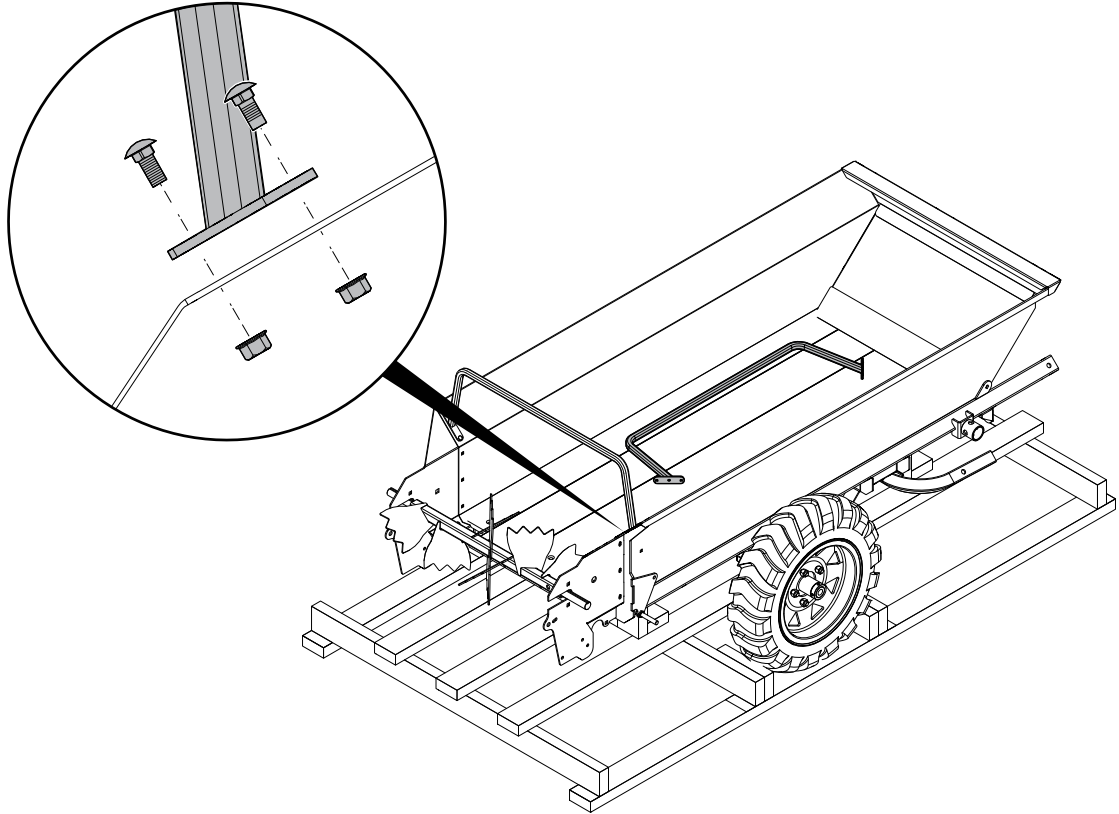

MX25

4

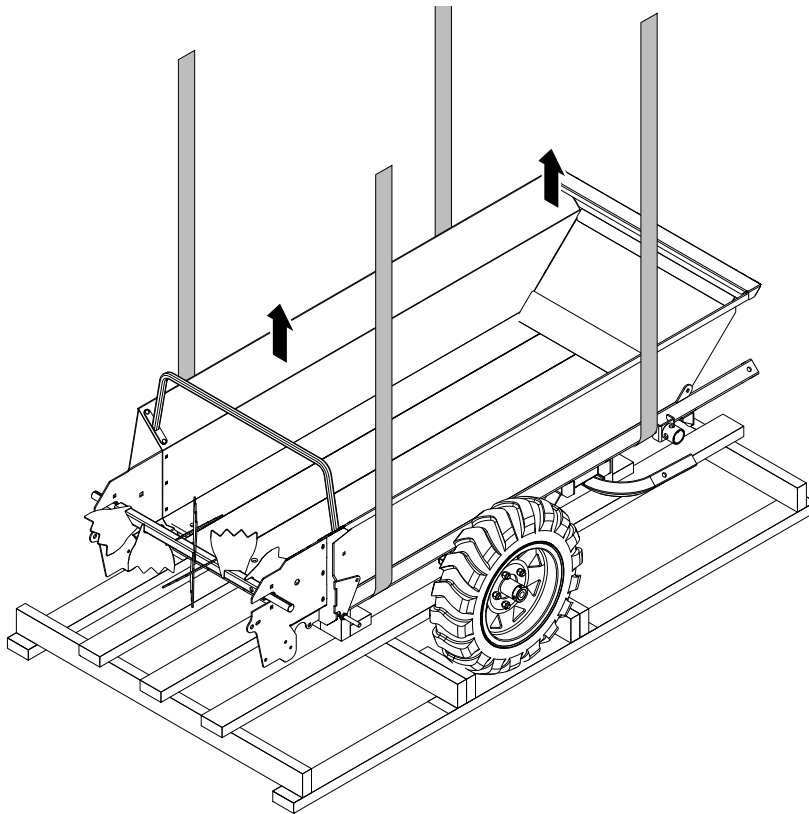

5

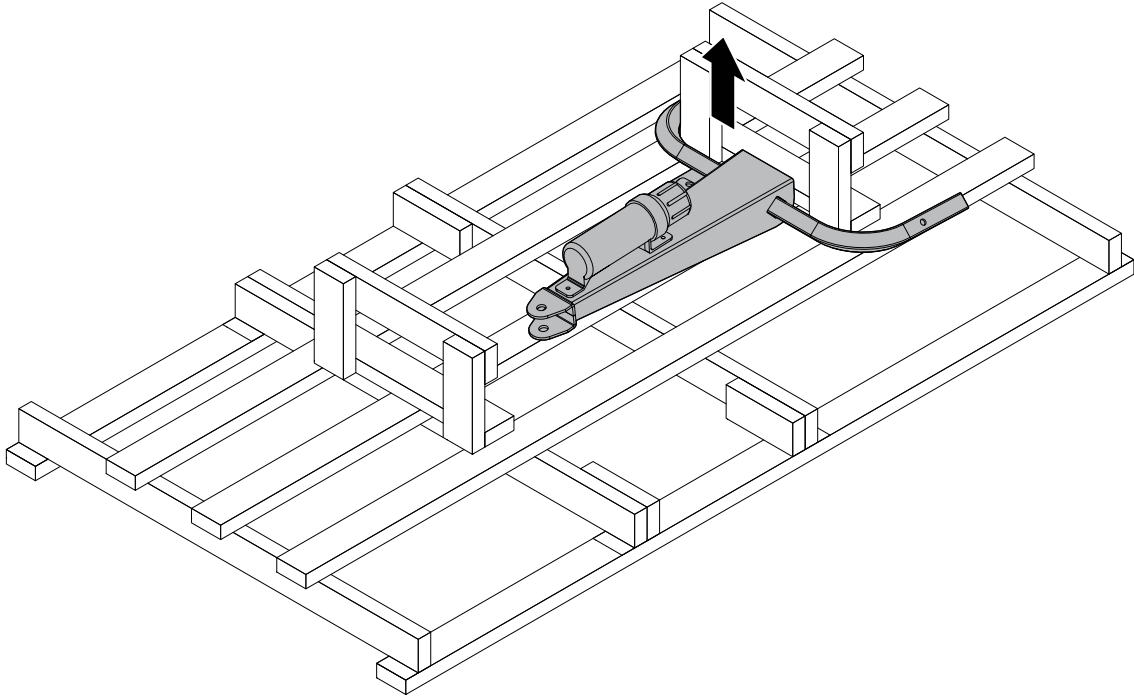

MX25

6

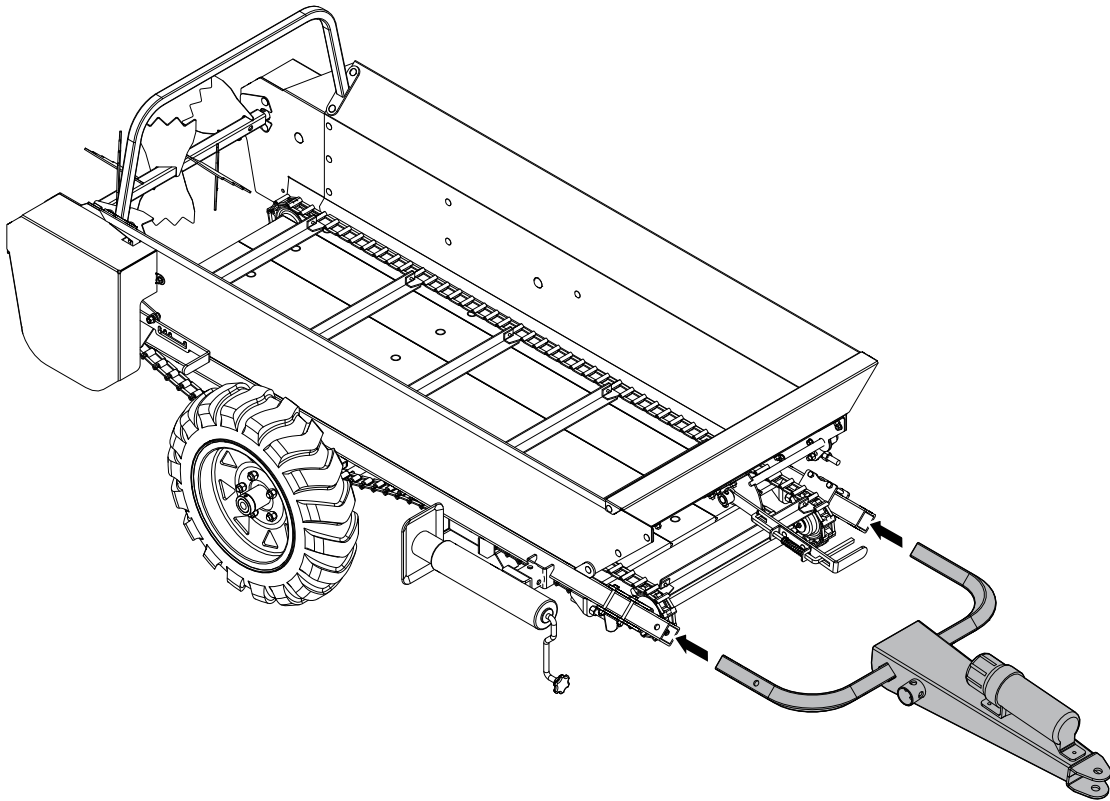

7

MX25]

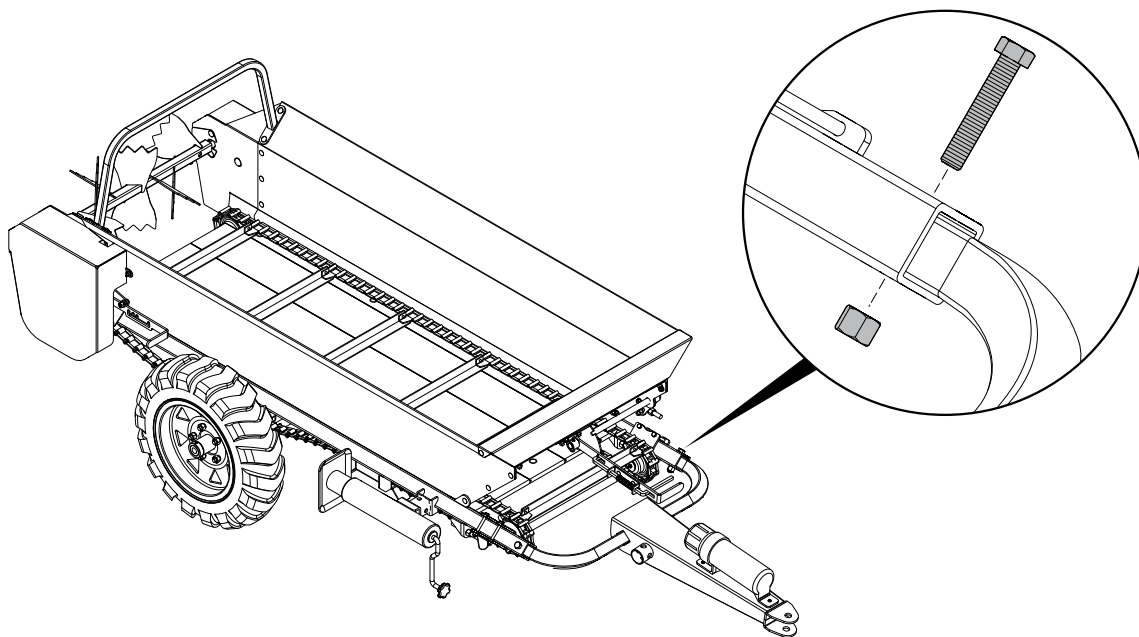

8

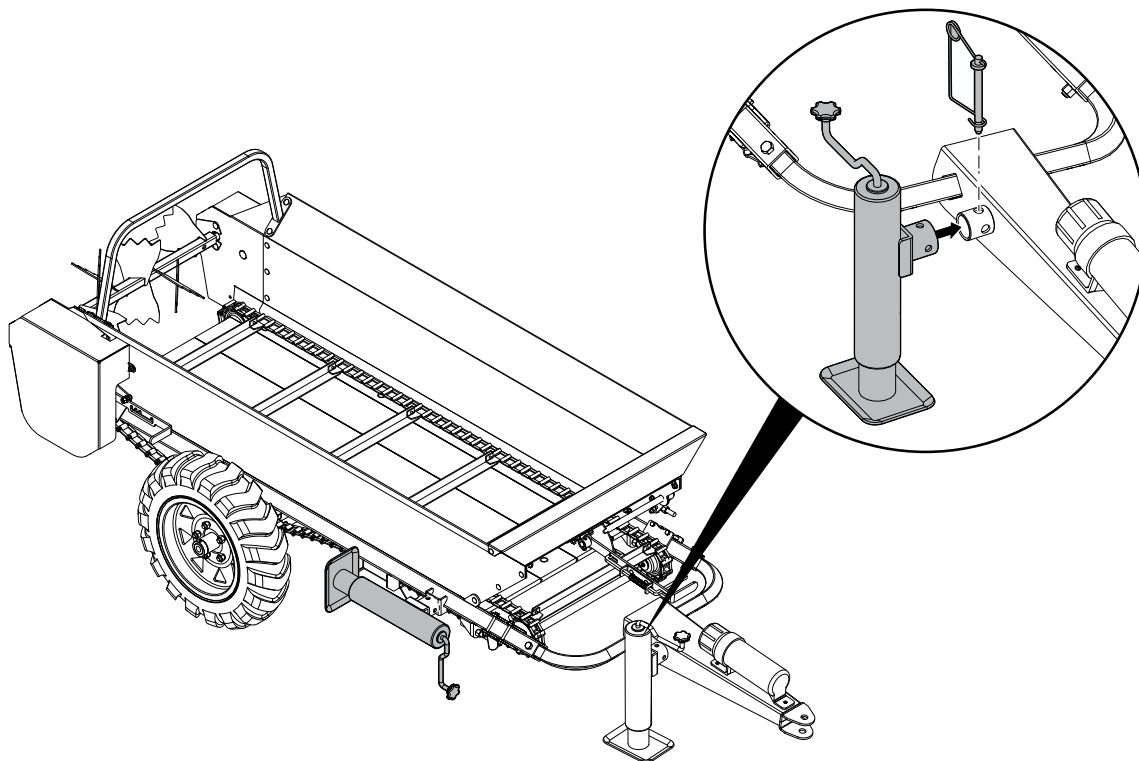

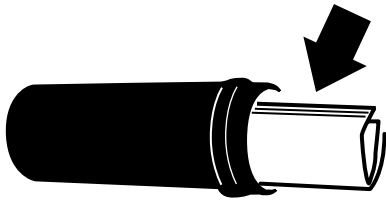

✓	<b>Pre-delivery Inspection</b>
Inspect for damage from shipping. Immediately contact the shipping company if damage is found.	
<b>MX Series Manure Spreaders</b>	
	Check Oil Level in Gearbox
	Apron Chain Moves Freely
	Belt Tension Checked
	Apron Chain Clutch System Moves Freely
	Beaters Turn Freely
	Hydraulic Connections
	Pulleys Aligned
	Fasteners Tight
	Grease Zerks / Lubricate Pivot Points
<b>Accessories</b>	
	Fines Pan
	End Gate
<b>Safety Checks</b>	
	All Safety Decals Installed
	All Lock Pins Align & Move Freely
	Guards and Shields Installed and Secured
	Check Function of Brake and Signal Lighting
	Safety Chain on Hitch
	Retainer Installed Through Ball Hitch
	Tire Pressure / Wheel Lugs at Proper Torque
	Review Operating and Safety Instructions

## Checking Bolt Torque

The tables shown give correct torque values for various bolts and capscrews. Tighten all bolts to the torque values specified in the table, unless indicated otherwise. Check tightness of bolts periodically.

**IMPORTANT! If replacing hardware, use fasteners of the same grade.**

**IMPORTANT! Torque figures indicated in the table are for non-greased or non-oiled threads. Do not grease or oil threads unless indicated otherwise. When using a thread locker, increase torque values by 5%.**

*Note: Bolt grades are identified by their head markings.*

Imperial Bolt Torque Specifications						
Bolt Diameter	Torque Value					
	SAE Gr. 2		SAE Gr. 5		SAE Gr. 8	
	lbf•ft	N•m	lbf•ft	N•m	lbf•ft	N•m
1/4"	6	8	9	12	12	17
5/16"	10	13	19	25	27	36
3/8"	20	27	33	45	45	63
7/16"	30	41	53	72	75	100
1/2"	45	61	80	110	115	155
9/16"	60	95	115	155	165	220
5/8"	95	128	160	215	220	305
3/4"	165	225	290	390	400	540
7/8"	170	230	420	570	650	880
1"	225	345	630	850	970	1320



SAE Gr. 2



SAE Gr. 5



SAE Gr. 8

Metric Bolt Torque Specifications				
Bolt Diameter	Torque Value			
	Gr. 8.8		Gr. 10.9	
	lbf•ft	N•m	lbf•ft	N•m
M3	0.4	0.5	1.3	1.8
M4	2.2	3	3.3	4.5
M6	7	10	11	15
M8	18	25	26	35
M10	37	50	52	70
M12	66	90	92	125
M16	166	225	229	310
M20	321	435	450	610
M30	1,103	1 495	1,550	2 100
M36	1,917	2 600	2,700	3 675



8.8



10.9

## Wheel Lug Torque

It is an extremely important safety procedure to apply and maintain proper wheel mounting torque on your trailer axle. Torque wrenches are the best method to assure the proper amount of torque is being applied to a fastener.

Wheel lugs should be torqued before first road use and after each wheel removal. Check and re torque after the first 10 miles (16 km), 25 miles (40 km), and again at 50 miles (80 km). Check periodically thereafter.



### WARNING!

**Wheel lug nuts must be installed and kept at the proper torque value to prevent loose wheels, broken studs, or possible separation of wheels from axle.**

- Start all lug nuts onto the threads by hand.
- Tighten lug nuts in stages, following the pattern shown in the Wheel Lug Nut Torque table.
- 

Wheel Lug Nut Torque				
Wheel Size	Units	1st Stage	2nd Stage	3rd Stage
8"	lbf•ft N•m	12–20 16–26	30–35 39–45.5	45–55 58.5–71.5
12"	lbf•ft N•m	20–25 26–32.5	35–40 45.5–52	50–60 65–78
13"	lbf•ft N•m	20–25 26–32.5	35–40 45.5–52	50–60 65–78
14"	lbf•ft N•m	20–25 26–32.5	50–60 65–78	90–120 117–156
15"	lbf•ft N•m	20–25 26–32.5	50–60 65–78	90–120 117–156
16"	lbf•ft N•m	20–25 26–32.5	50–60 65–78	90–120 117–156

Wheel Lug Torque Pattern

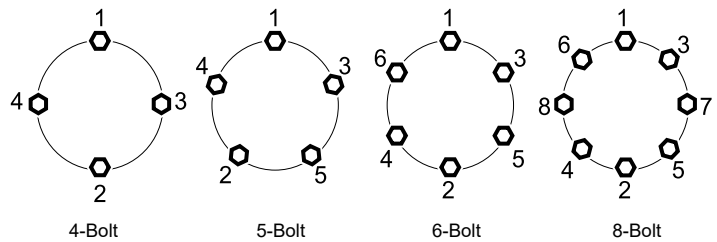



A series of horizontal lines for writing, starting with two lines that are slightly indented from the left margin, followed by a continuous series of lines down the page.