

SETUP INSTRUCTIONS

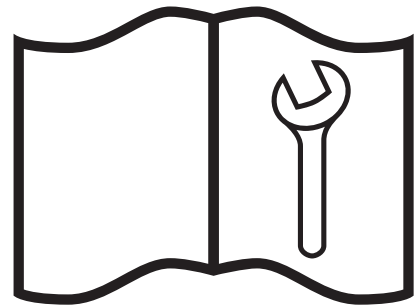

WX15V

WX20V

Safety

WARNING!

Do not assemble the machine before you read the assembly instructions in this manual. Make sure that you understand the safety information and each step of the procedure before you assemble the machine.

Keep this manual with you and available for frequent reference while you assemble the machine.

S136W-02

WARNING!

Use a hoist when you lift machine components that weigh 50 lb (23 kg) or more. Do not lift machine components that weigh more than you can lift without strain or injury.

S137W-01

WARNING!

Use lift equipment with a lift capacity that is greater than the weight of the machine component. Use jack stands or wood blocks to support the machine and make it safe for assembly.

S138W-02

WARNING!

Use the correct tools and equipment to assemble the machine. The use of incorrect tools can create safety hazards. A tool that breaks or slips during assembly risks personal injury. Repair or replace equipment or tools that are broken or defective.

S139W-01

WARNING!

All lift equipment (for example, straps, slings, chains, or ratchet blocks) must comply with the applicable local laws, standards, and regulations. Wallenstein Equipment does not accept responsibility for the use of unsafe equipment and work practices.

S140W-02

WARNING!

Know the location of overhead power lines and obstructions and keep away from them when you lift the machine. Contact with power lines can cause electrocution. Contact with overhead obstructions can damage the machine or components.

S141W-02

WARNING!

Do not start or operate the machine before you read the Operator's Manual. Make sure that you fully understand all the safety, operation, and maintenance information before you operate the machine.

Keep the Operator's Manual with the machine and available for reference at all times.

S132W-02

WARNING!

Make sure that all the fasteners are installed and torqued to the correct specifications. For more information, see *Specifications on page 9*.

CAUTION!

Keep the assembly area clean and free of debris to prevent slips, trips, or falls.

S143C-01

IMPORTANT! Inspect the machine for damage from shipping. Contact the shipping company immediately if you find any damage to the machine.



Some components are attached to the skid with a shipping bracket and/or screws. Make sure that you only discard shipping brackets and screws, and not machine components.

Put the crate in a large, open area for assembly. Make sure that you can access the machine from all sides.

Learn what the safety labels mean and know the safety hazards.

WX15V

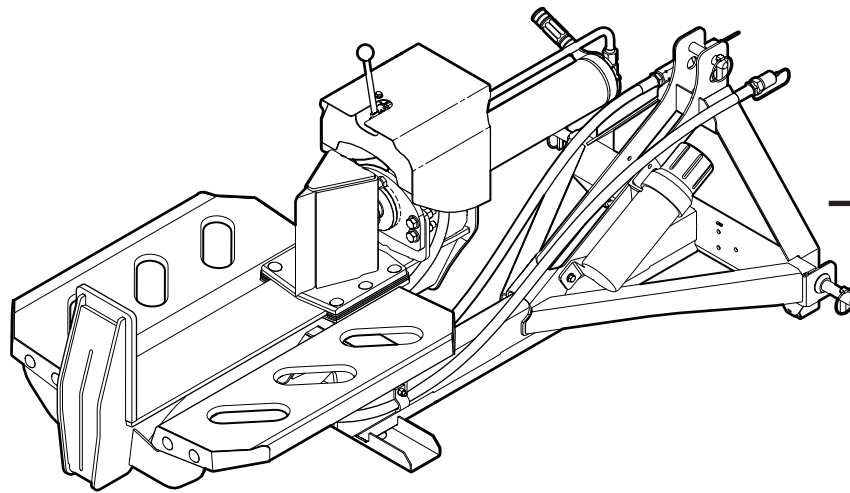

WX15V

WX20V

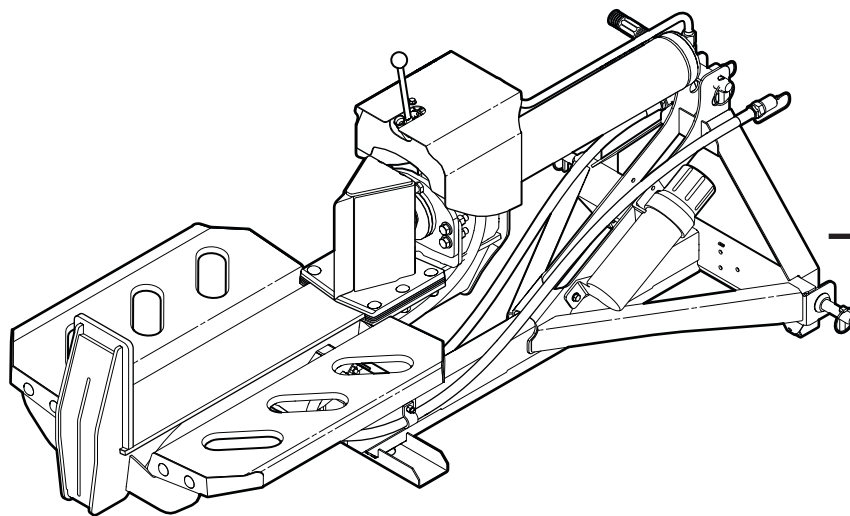

WX20V

The assembly hardware and Operator's Manual are in the document storage tube.

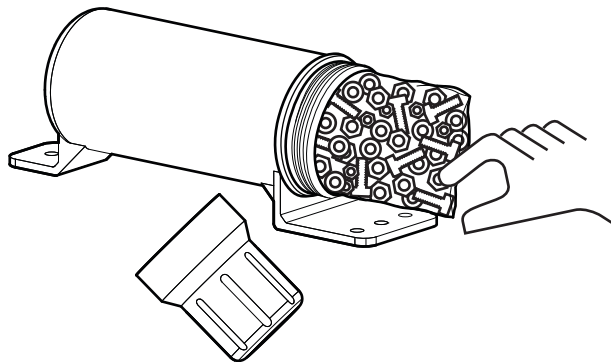

i

1

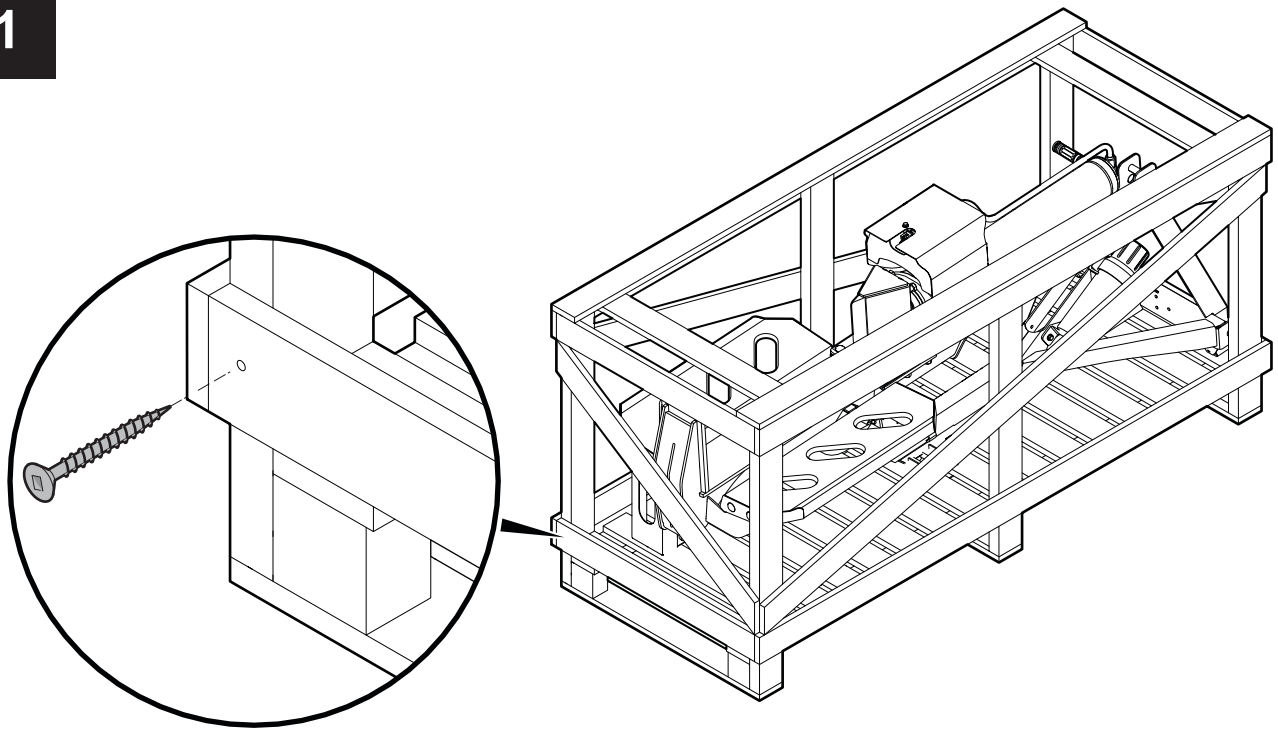

2

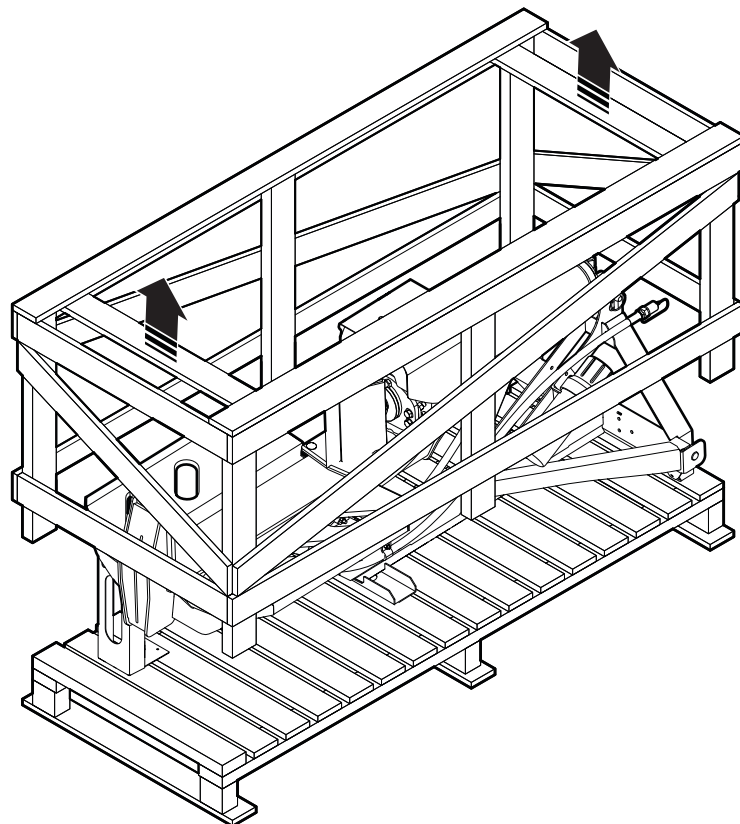

3

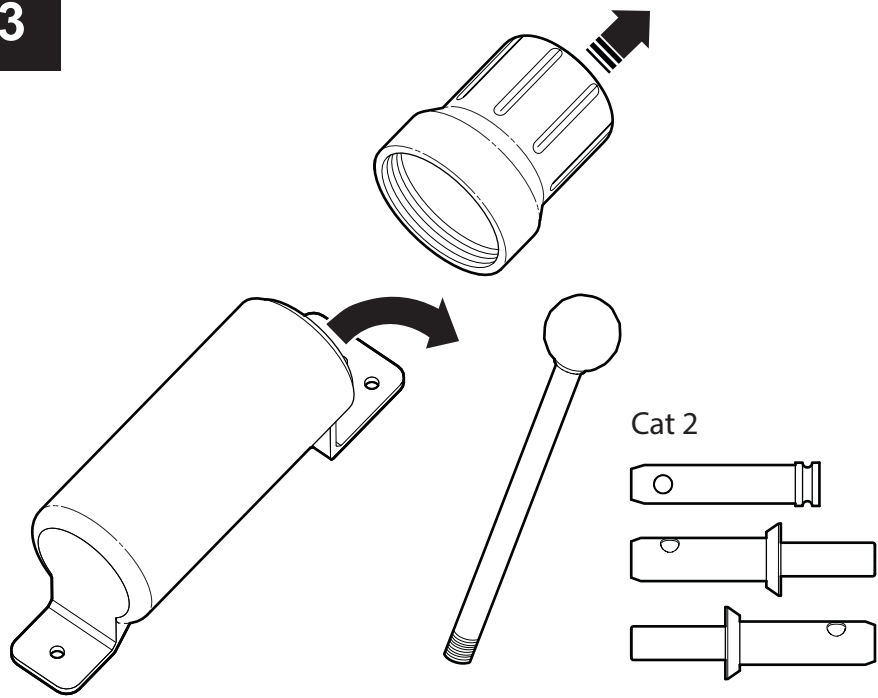

4

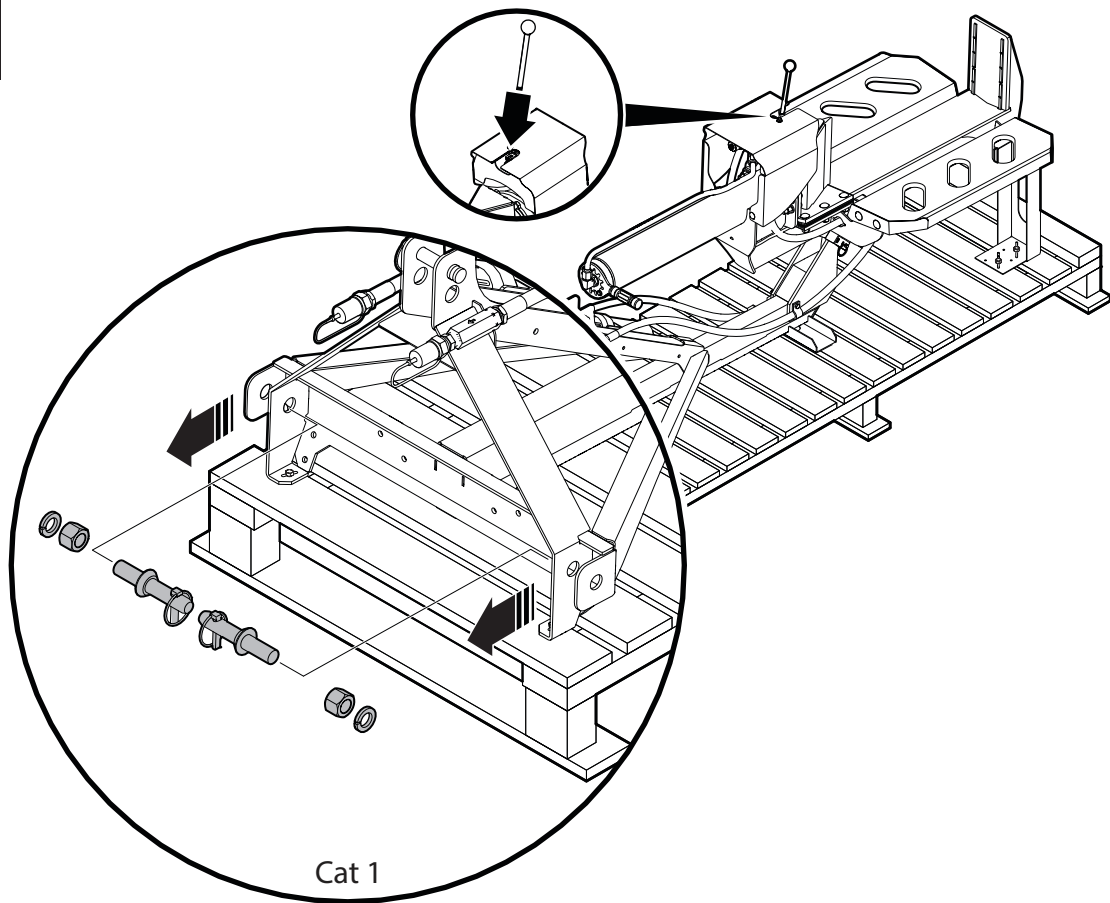

5

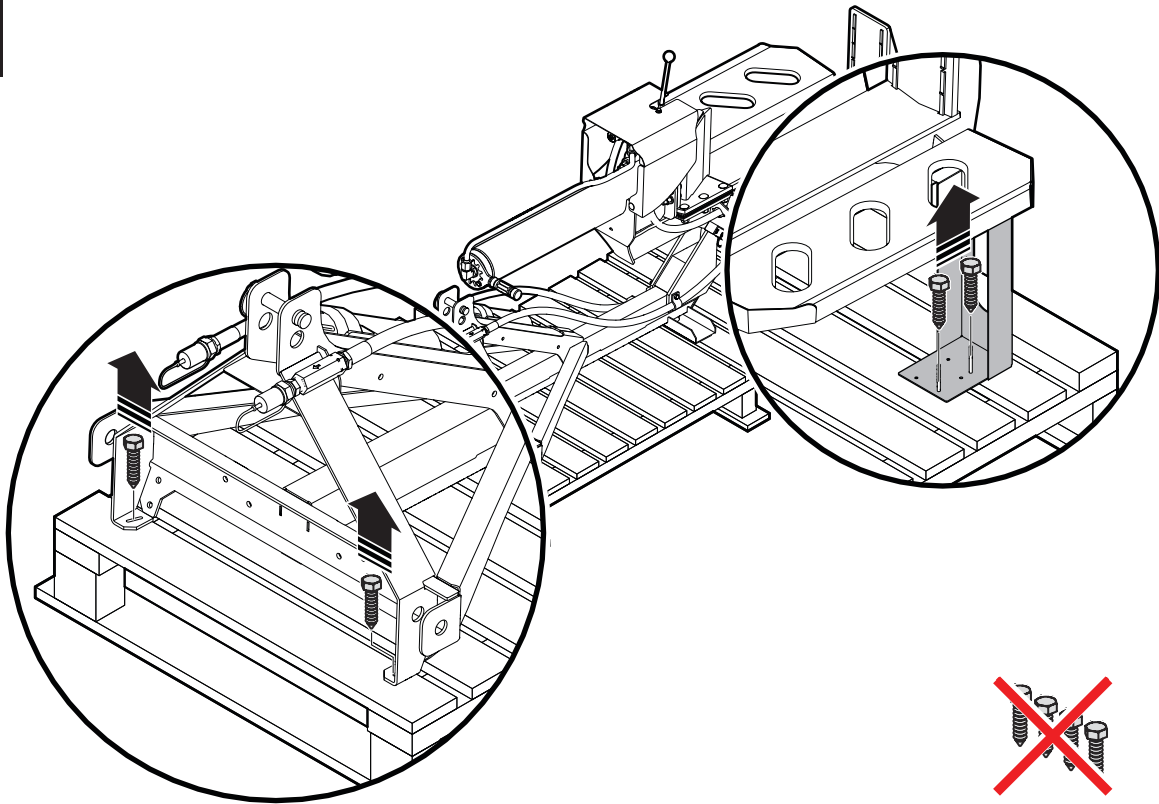

6

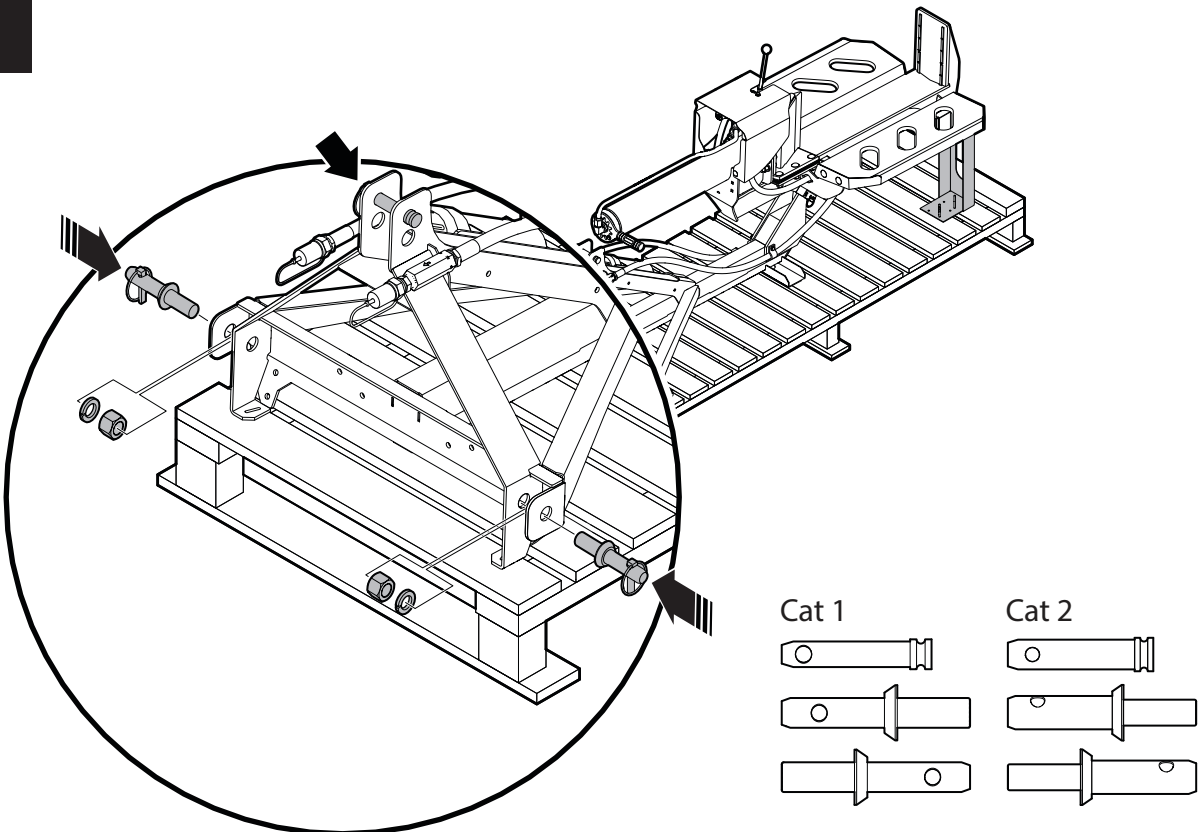

7

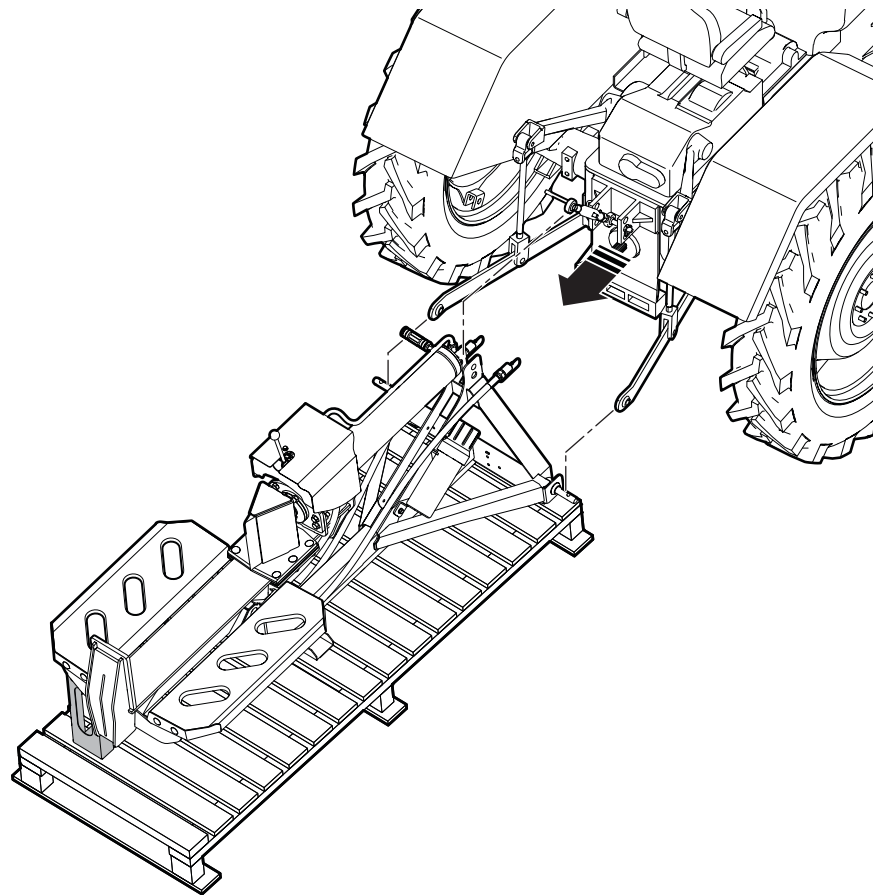

8

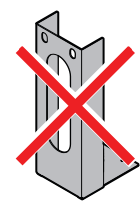
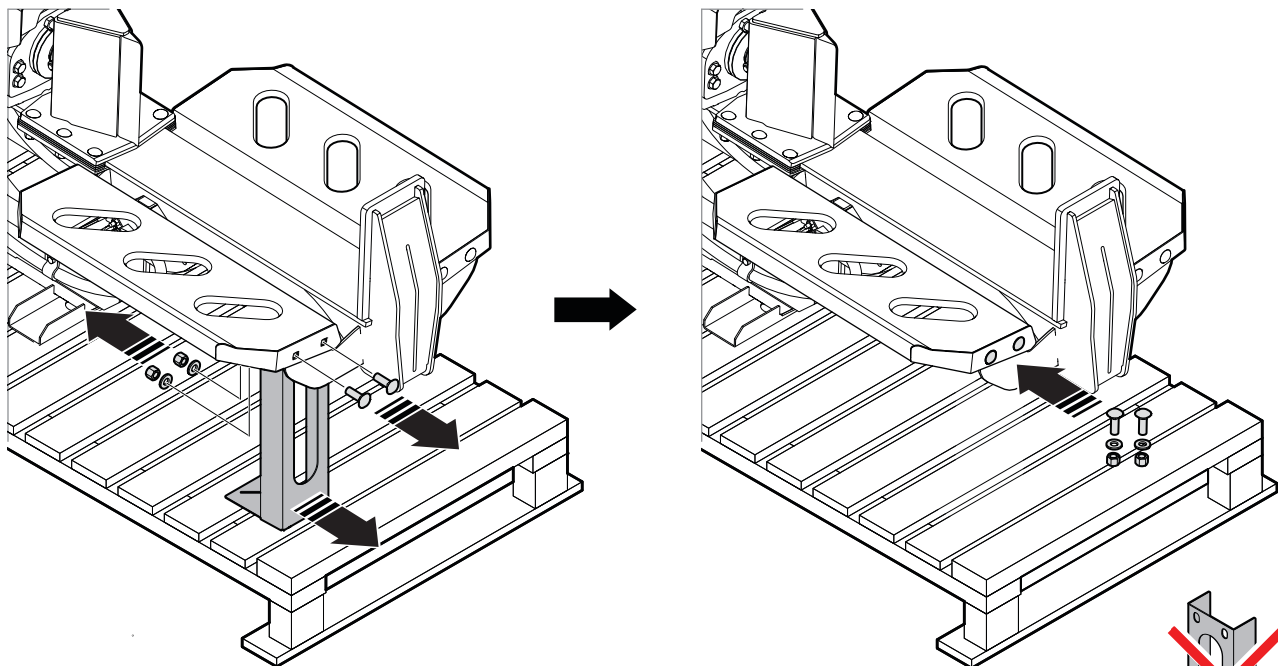

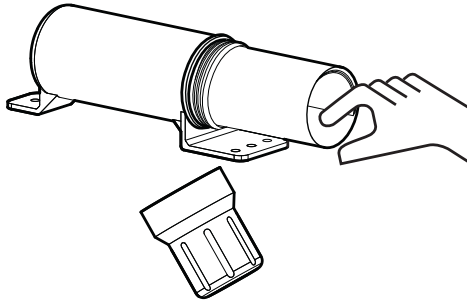

Before First Use Checklist

Do the following inspections before you use the machine for the first time.

- _____ Three-point hitch connects to the tractor correctly.
- _____ Machine controls function correctly.
- _____ Split-bed latch functions correctly and the split bed moves freely.
- _____ All fasteners are torqued to the correct specifications.
- _____ All lubrication locations are lubricated.
- _____ Hydraulic system and cylinders function correctly.
- _____ Hydraulic controls move freely.
- _____ Hydraulic connections are tight, and tubes, hoses, and fittings are in good condition.
- _____ There are no hydraulic leaks.
- _____ Operator's Manual is in the document tube.
- _____ Purchased accessories are included, if applicable.

Safety Checks

- _____ All safety labels are applied and legible.
- _____ All guards and shields are installed.
- _____ A retainer (linchpin) is installed through each hitch connection.
- _____ Operation and safety instructions were reviewed.

Specifications

This section is provided for reference.

Bolt Torque

IMPORTANT! If you replace hardware, use fasteners of the same grade.

IMPORTANT! The torque specifications in these tables are for non-greased or non-oiled threads. Do not grease or oil fastener threads unless otherwise indicated. When using a thread lock, increase the specified torque 5%.



Bolt grades are identified by the marks on top of the bolt head.

These bolt torque specification tables give the correct torque settings for common bolts and capscrews. Tighten all bolts to the torque that is specified in the table, unless otherwise indicated. Check the bolt tightness periodically.

Imperial Bolt Torque Specifications

Bolt Diameter	Torque					
	SAE Gr. 2		SAE Gr. 5		SAE Gr. 8	
	lbf•ft	N•m	lbf•ft	N•m	lbf•ft	N•m
1/4 inch	6	8	9	12	12	17
5/16 inch	10	13	19	25	27	36
3/8 inch	20	27	33	45	45	63
7/16 inch	30	41	53	72	75	100
1/2 inch	45	61	80	110	115	155
9/16 inch	60	95	115	155	165	220
5/8 inch	95	128	160	215	220	305
3/4 inch	165	225	290	390	400	540
7/8 inch	170	230	420	570	650	880



SAE Gr. 2



SAE Gr. 5



SAE Gr. 8

Metric Bolt Torque Specifications

Bolt Diameter	Torque			
	Gr. 8.8		Gr. 10.9	
	lbf•ft	N•m	lbf•ft	N•m
M3	0.4	0.5	1.3	1.8
M4	2.2	3	3.3	4.5
M6	7	10	11	15
M8	18	25	26	35
M10	37	50	52	70
M12	66	90	92	125
M14	83	112	116	158
M16	166	225	229	310
M20	321	435	450	610
M30	1,103	1,495	1,550	2,100



8.8



10.9

Hydraulic Fitting Torque

Tighten flare-type tube fittings:

1. Check the flare and flare seat for defects that might cause leaks.
2. Align the tube with the fitting before tightening.
3. Hand-tighten the swivel nut until it is snug.
4. To prevent the tube from twisting, use two wrenches. Place one wrench on the connector body and tighten the swivel nut with the second wrench. Torque the fitting to the correct specification.

If a torque wrench is not available, use the flats from finger tight (FFFT) method.

Hydraulic Fitting Torque Specifications

Tube size OD	Hex size across flats	Torque		Flats from finger tight	
		lbf•ft	N•m	Flats	Turns
Inches	Inches				
3/16	7/16	6	8	2	1/6
1/4	9/16	11–12	15–17	2	1/6
5/16	5/8	14–16	19–22	2	1/6
3/8	11/16	20–22	27–30	1-1/4	1/6
1/2	7/8	44–48	59–65	1	1/6
5/8	1	50–58	68–79	1	1/6
3/4	1-1/4	79–88	107–119	1	1/8
1	1-5/8	117–125	158–170	1	1/8

These specifications are for fittings that are not lubricated.



MAKING WORK FEEL MORE LIKE PLAY™

WallensteinEquipment.com

