

# PARTS MANUAL

---

Serial Number 2E9US1116HS040411 & up

## BXMT3213 TRAILER CHIPPER-SHREDDER

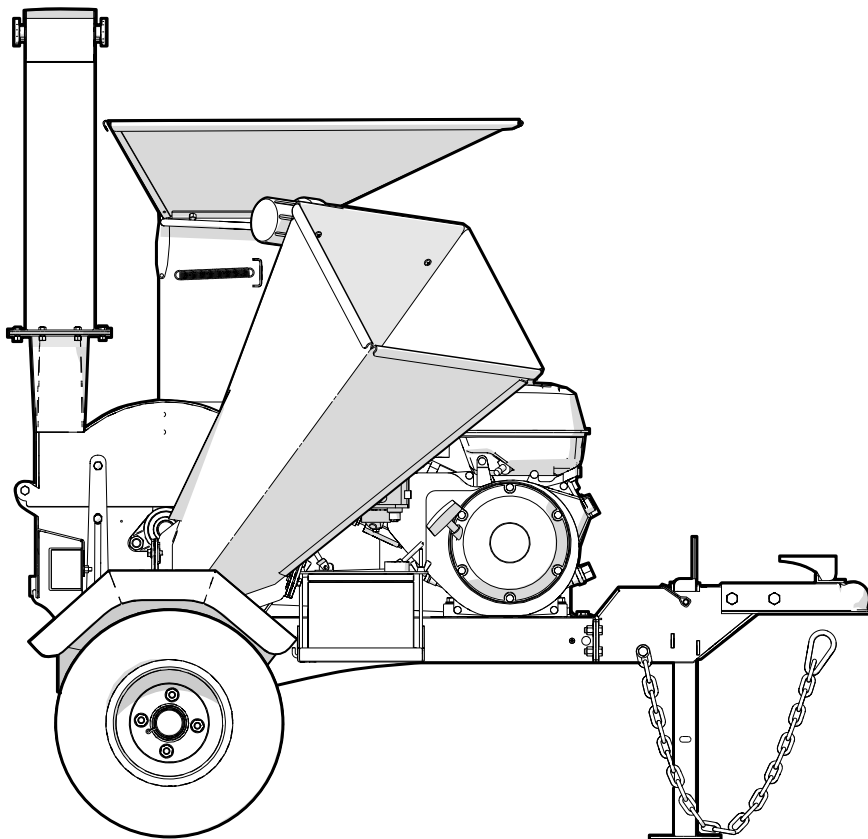

## Foreword

EMB Manufacturing has prepared this parts manual to assist customers in ordering quality OEM replacement parts.

Regular maintenance, and replacing old, worn or broken parts with the correct OEM parts, is essential in prolonging the life of your EMB product. Please refer to this manual to identify replacement parts.

To order parts, contact your Wallenstein dealer or distributor. Have the product model and serial number handy.

If your dealer is no longer available, please go to our website: <http://www.wallensteinequipment.com> and click on the [Dealer Locator](#) to find the nearest dealer.

All information contained in this parts manual is current as per the revision date at the bottom of the page. EMB reserves the right to change product specifications at any time without notice.

If your product specifications differ from those contained in this manual, contact EMB Manufacturing for information.

Reproduction of this parts manual of any kind is prohibited without prior written permission from EMB Manufacturing.

### **WARNING!**

**Refer to the operators manual for safe operation and maintenance.**

**Maintenance should be performed by trained personnel only.**

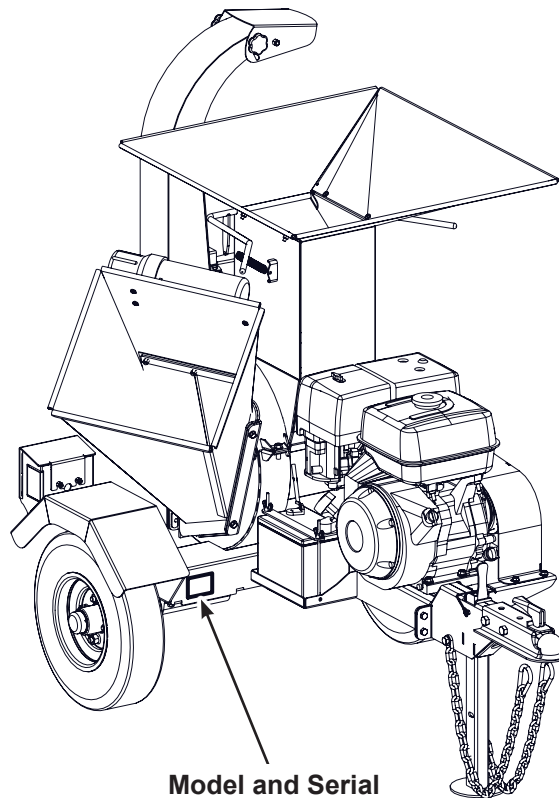

**Model and Serial  
Number Location**

**EMB Manufacturing inc.  
4144 Boomer Line, St. Clements ON, Canada, N0B 2M0  
[www.wallensteinequipment.com](http://www.wallensteinequipment.com)**

# Contents

<b>Main Parts</b> .....	<b>4</b>
<b>Blower Assembly</b> .....	<b>5</b>
<b>Discharge Chute Assembly</b> .....	<b>6</b>
<b>Rotor Assembly</b> .....	<b>7</b>
<b>Tongue Assembly</b> .....	<b>8</b>
<b>TorFlex with Hub Assembly</b> .....	<b>8</b>
<b>Hopper Flap Detail</b> .....	<b>9</b>
<b>Decal Layout</b> .....	<b>10</b>
<b>Accessories</b> .....	<b>12</b>
<b>Common Bolt Torque Values</b> .....	<b>13</b>

**Main Parts**

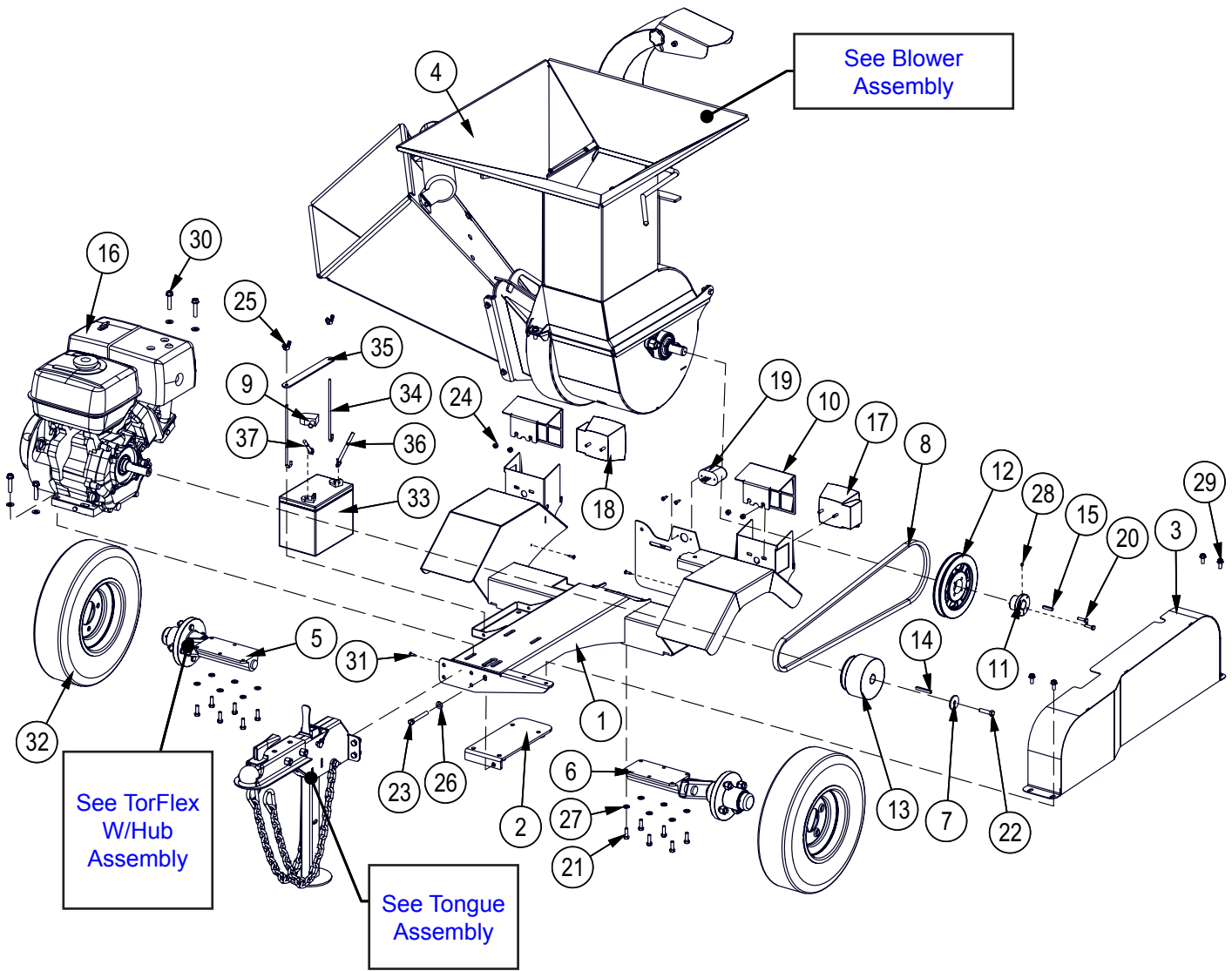

Item No.	Part No.	Description	Qty
1	1056W613	Main Base	1
2	1056W611	Belt Tightener	1
3	1056W615	Shield	1
4	1056A901	Blower Assembly for BXMT	1
5	1056A602	Torflex with Hub, RH	1
6	1056A603	Torflex with Hub, LH	1
7	1056L665	Clutch Washer	1
8	Z41160	Single Belt, B64	1
9	Z93403	Garden Tractor Terminal Protector - Red	1
10	2089L351	Light Guard	2
11	Z41510	Hub, L x 1"	1
12	Z41613	Sheave, MBL74 x L	1
13	Z41803	Centrifugal Clutch, 1B36 x 1"	1
14	Z46531	Key, 1/4" x 1/4" x 2"	1
15	Z46534	Key, 1/4" x 1/4" x 1-1/4"	1
16	Z47147	Honda GX390UQXE6, Electric	1
17	Z61106	STTL Lamp, Square LH	1
18	Z61107	STT Lamp, Square RH	1
19	Z61301	License Lamp, White	1

Item No.	Part No.	Description	Qty
20	Z71110	Hex Bolt, 1/4NC x 1"	2
21	Z71210	Hex Bolt, 5/16NC x 1"	12
22	Z71377	Hex Bolt, 3/8NF x 1-1/2"	1
23	Z71391	Hex Bolt, 3/8NC x 3" Full Threads	1
24	Z72211	Hex Lock Nut, 1/4NC	4
25	Z72921	Wing Nut, 1/4NC	2
26	Z73131	SAE Washer, 3/8"	5
27	Z73331	Split Lock Washer, 3/8"	12
28	Z74102	Set Screw, #10NC x 1/4"	1
29	Z76121	Flange Bolt, 5/16NC x 3/4"	4
30	Z76138	Flange Bolt, 3/8NC x 1-3/4"	4
31	Z76712	Self-tapping Screw, #10 x 3/4"	5
32	Z91301	4.80-8 LRB SportTrail 4on4"	2
33	Z93201	Battery, 250CCA	1
34	Z93202	J-Hook, 1/4" x 7"	2
35	Z93207	Hold-Down Strap, 1" x 8-1/2"	1
36	Z93210	Battery Cable, Negative x 25"	1
37	Z93212	Battery Cable, Positive x 28"	1

**Blower Assembly**

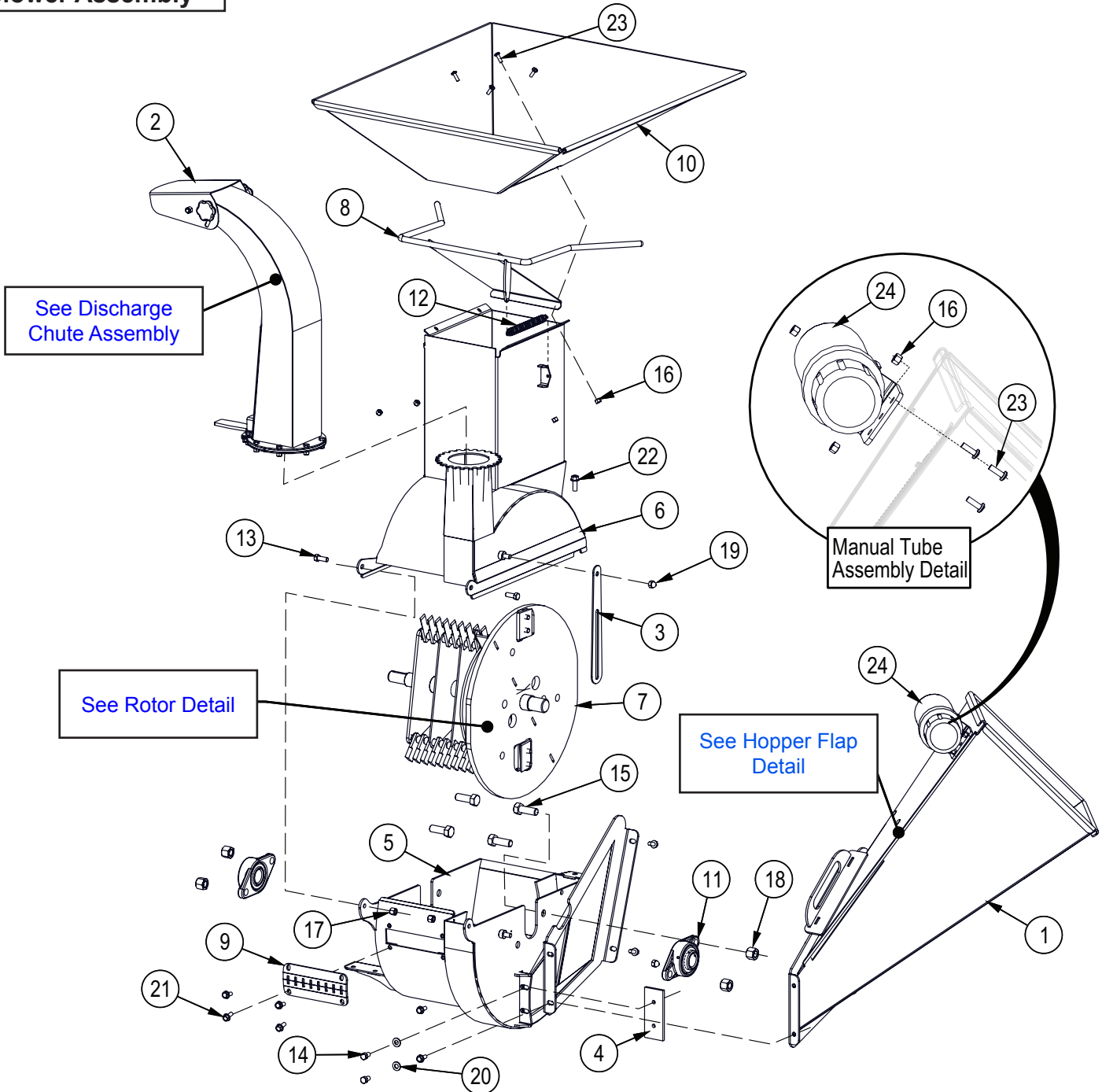

Item No.	Part No.	Description	Qty
1	1018W107	Chipper Chute	1
2	1056A302	Assembly, Discharge Chute	1
3	1056L229	Positive Stop Plate	1
4	1056M304	Knife, 3" Ledger	1
5	1056W101	Housing, Bottom Rotor	1
6	1056W102	Housing, Upper Rotor	1
7	1056W103	Rotor	1
8	1056W107	Shredder, Chute Flapper	1
9	1056W610	Concave	1
10	1056W617	Hopper Shredder Top	1
11	Z25103	2-Bolt Flange Bearing UCFL206-20	2
12	Z31301	Ext Spring 17mmOD x 140mm x 0.080"	1
13	Z71310	Hex Bolt, 3/8NC x 1"	2

Item No.	Part No.	Description	Qty
14	Z71372G8	Hex Bolt, 3/8NF x 5/8" G8	2
15	Z71617	Hex Bolt, 5/8NC x 1-3/4"	4
16	Z72211	Hex Lock Nut, 1/4NC	7
17	Z72231	Hex Lock Nut, 3/8NC	2
18	Z72261	Hex Lock Nut, 5/8NC	4
19	Z72911	Acorn Nut, 3/8NC	2
20	Z73131	SAE Washer, 3/8"	2
21	Z76121	Flange Bolt, 5/16NC x 3/4"	8
22	Z76134	Flange Bolt, 3/8NC x 1"	1
23	Z78301	Machine Screw, 1/4NC x 3/4"	7
24	Z96503	Manual Tube, 3-1/2" Short	1

**Discharge Chute Assembly**

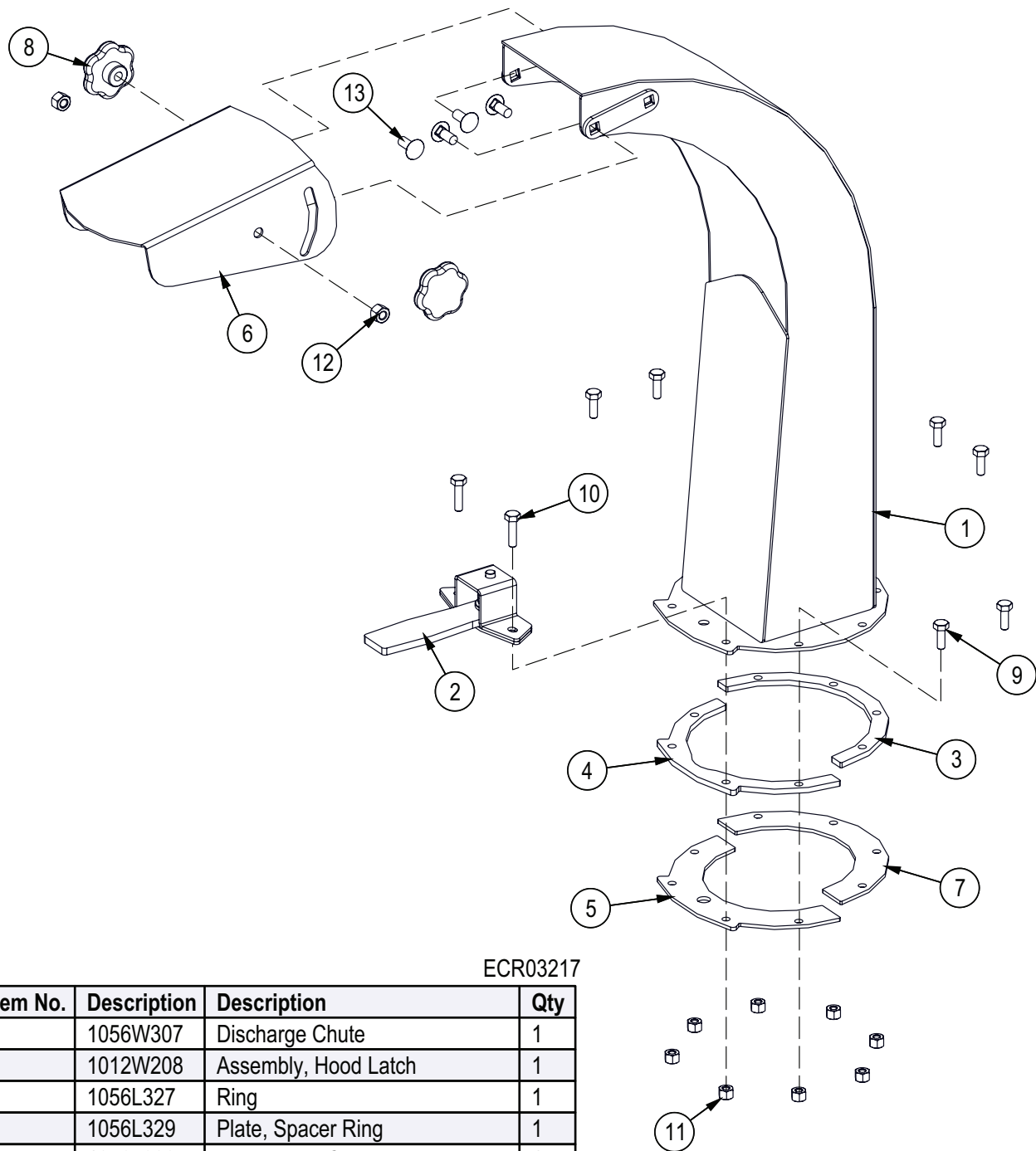

ECR03217

Item No.	Description	Description	Qty
1	1056W307	Discharge Chute	1
2	1012W208	Assembly, Hood Latch	1
3	1056L327	Ring	1
4	1056L329	Plate, Spacer Ring	1
5	1056L330	Plate, Hood Capture	1
6	1056L333	Deflector, Discharge Chute	1
7	1056L334	Ring	1
8	Z19313	Hand Knob, 5/16NC Female Stud	2
9	Z71107	Hex Bolt, 1/4NC x 3/4"	6
10	Z71110	Hex Bolt, 1/4NC x 1"	2
11	Z72211	Hex Lock Nut, 1/4NC	8
12	Z72221	Hex Lock Nut, 5/16NC	2
13	Z76221	Carriage Bolt, 5/16NC x 3/4"	4

**Rotor Assembly**

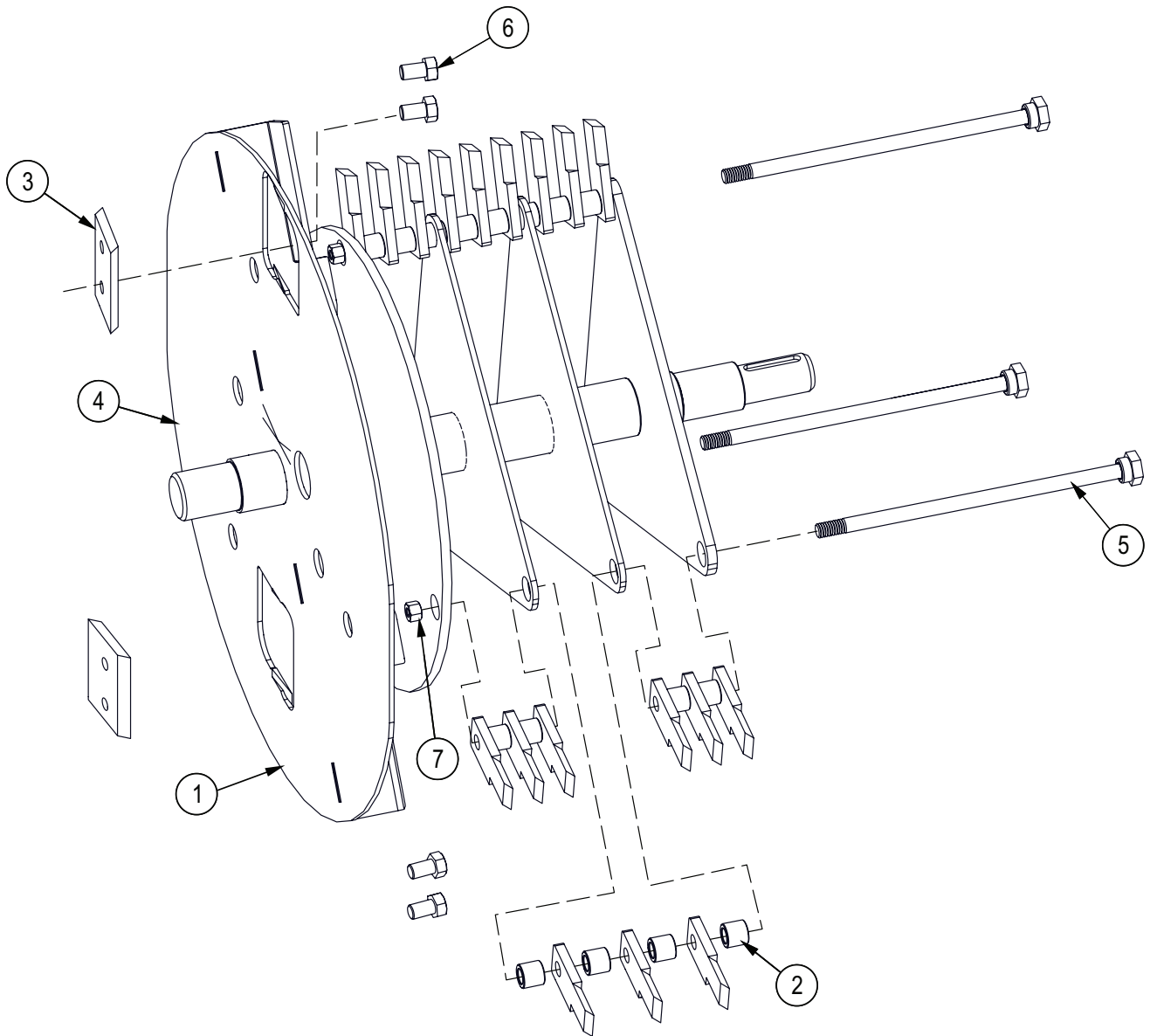

Item No.	Part No.	Description	Qty
1	1056M108	Knife,Shredder	27
2	1056M115	Spacer, Shredder .580	24
3	1056M303	Knife, 3" Rotor	2
4	1056W103	Rotor	1
5	1056W614	Hammer Retainer Pin	3
6	Z71372G8	Hex Bolt, 3/8NF x 5/8" G8	4
7	Z72231	Hex Lock Nut, 3/8NC	3

**NOTE**  
 It is recommended that the clearance between the rotor and stationary blades be set and maintained at 1/32–1/16" (.76–1.52 mm) to obtain the best performance.

ECR03435

**Tongue Assembly**

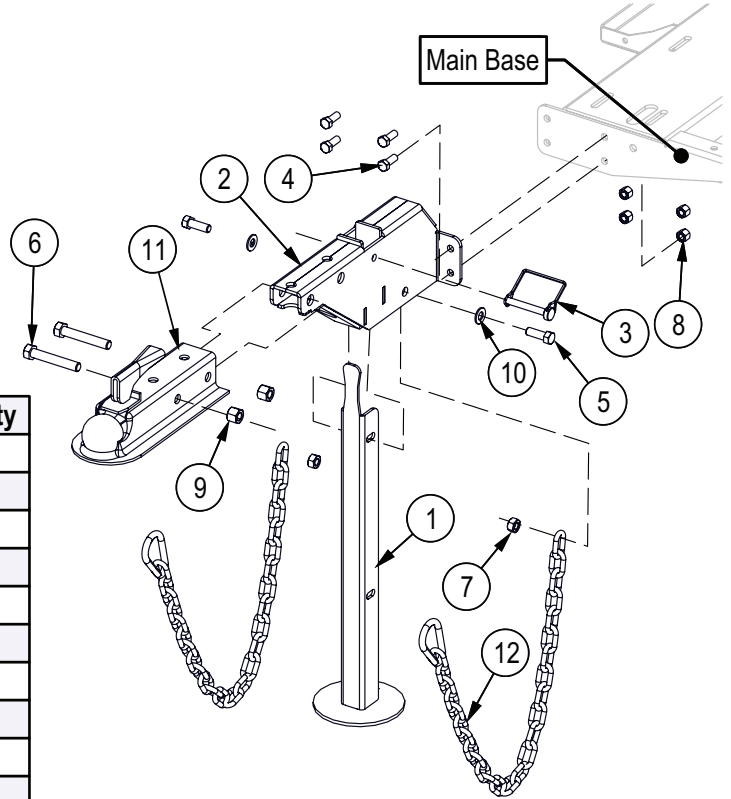

Item No.	Part No.	Description	Qty
1	1056W402	Jack Stand	1
2	1056W601	Main Spine	1
3	Z12432	Snap Lock Pin, 3/8" x 2-1/2"	1
4	Z71310	Hex Bolt, 3/8NC x 1"	4
5	Z71412	Hex Bolt, 7/16NC x 1-1/4"	2
6	Z71530	Hex Bolt, 1/2NC x 3"	2
7	Z72141	Hex Nut, 7/16NC	2
8	Z72231	Hex Lock Nut, 3/8NC	4
9	Z72251	Hex Lock Nut, 1/2NC	2
10	Z73142	SAE Washer, 7/16"	2
11	Z91614	Hitch Coupler, 2" Ball x 2" x 3500lbs	1
12	Z92307	Safety Chain, 1/4" x 3ft with Snap	2

**TorFlex with Hub Assembly**

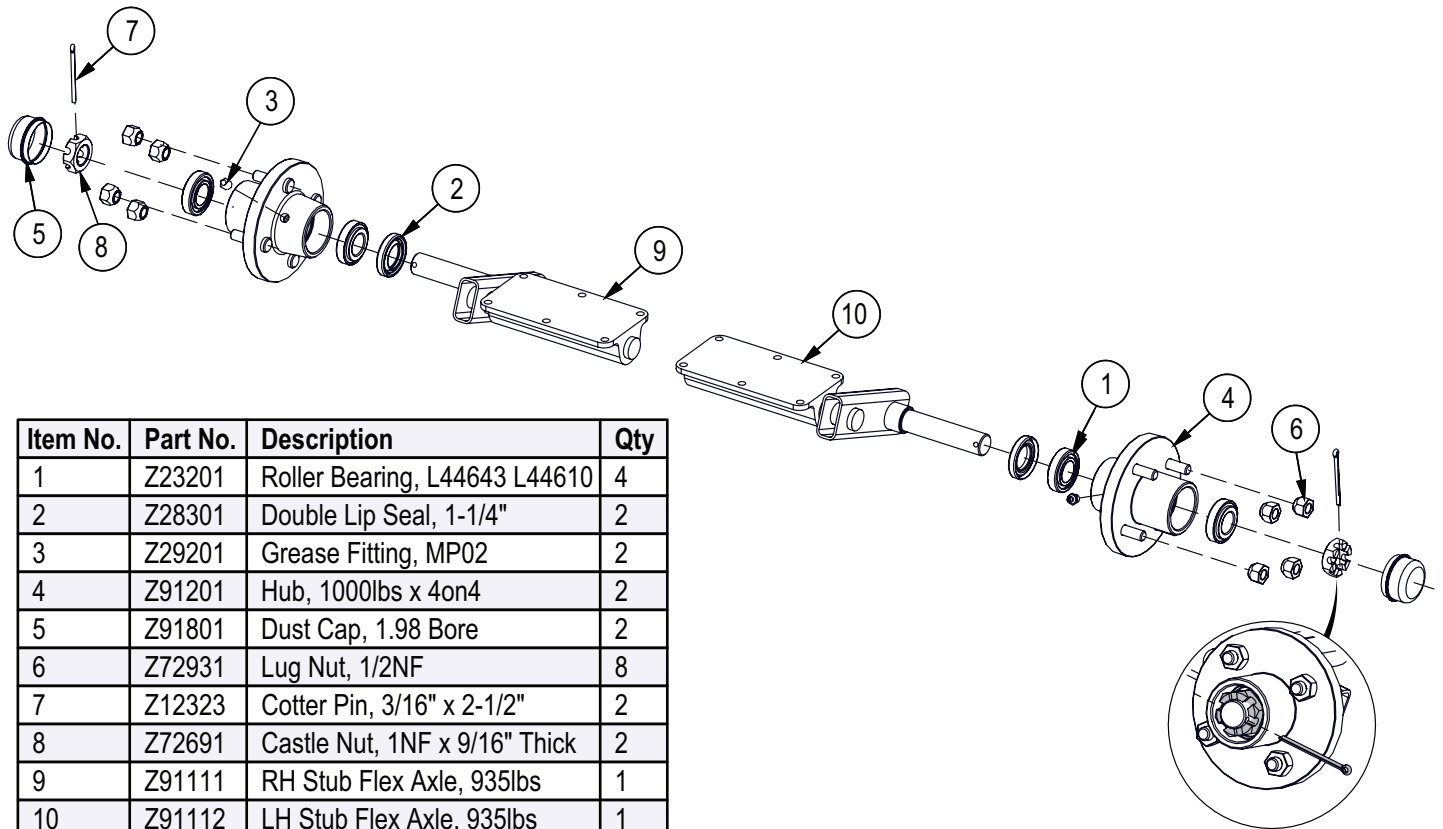

Item No.	Part No.	Description	Qty
1	Z23201	Roller Bearing, L44643 L44610	4
2	Z28301	Double Lip Seal, 1-1/4"	2
3	Z29201	Grease Fitting, MP02	2
4	Z91201	Hub, 1000lbs x 4on4	2
5	Z91801	Dust Cap, 1.98 Bore	2
6	Z72931	Lug Nut, 1/2NF	8
7	Z12323	Cotter Pin, 3/16" x 2-1/2"	2
8	Z72691	Castle Nut, 1NF x 9/16" Thick	2
9	Z91111	RH Stub Flex Axle, 935lbs	1
10	Z91112	LH Stub Flex Axle, 935lbs	1



**Hopper Flap Detail**

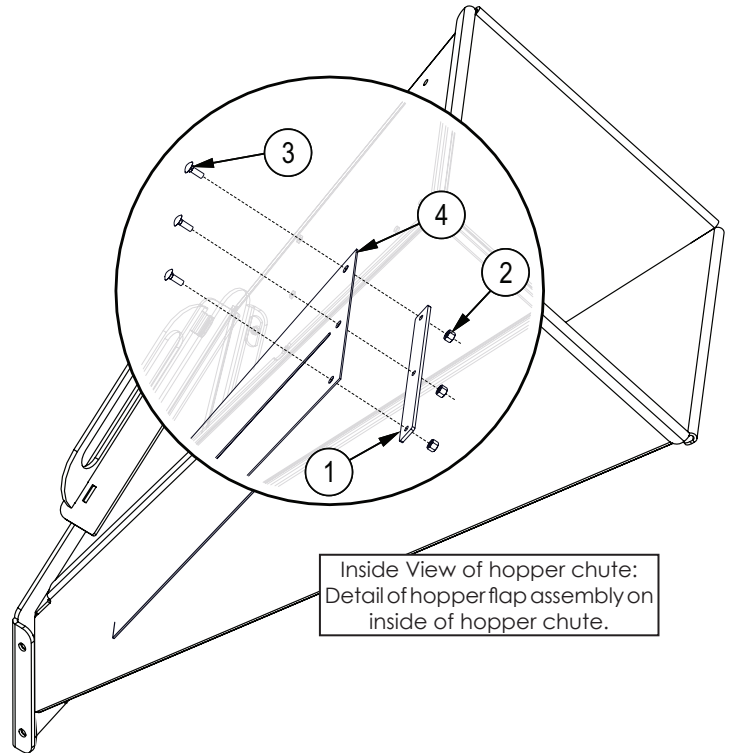

Item No.	Part No.	Description	Qty
1	1018L994	Chipper Chute Flap Clamp	1
2	Z72211	Hex Lock Nut, 1/4NC	3
3	Z76211	Carriage Bolt, 1/4NC x 3/4"	3
4	1056S604	Flap, Hopper	1

**Decal Layout**

**IMPORTANT!** If parts are replaced that have safety signs on them, new signs must be applied. Safety signs must always be replaced if they become damaged, are removed, or become illegible.

Safety signs are included in the product decal kit available from your authorized dealer. Decals are not available separately.

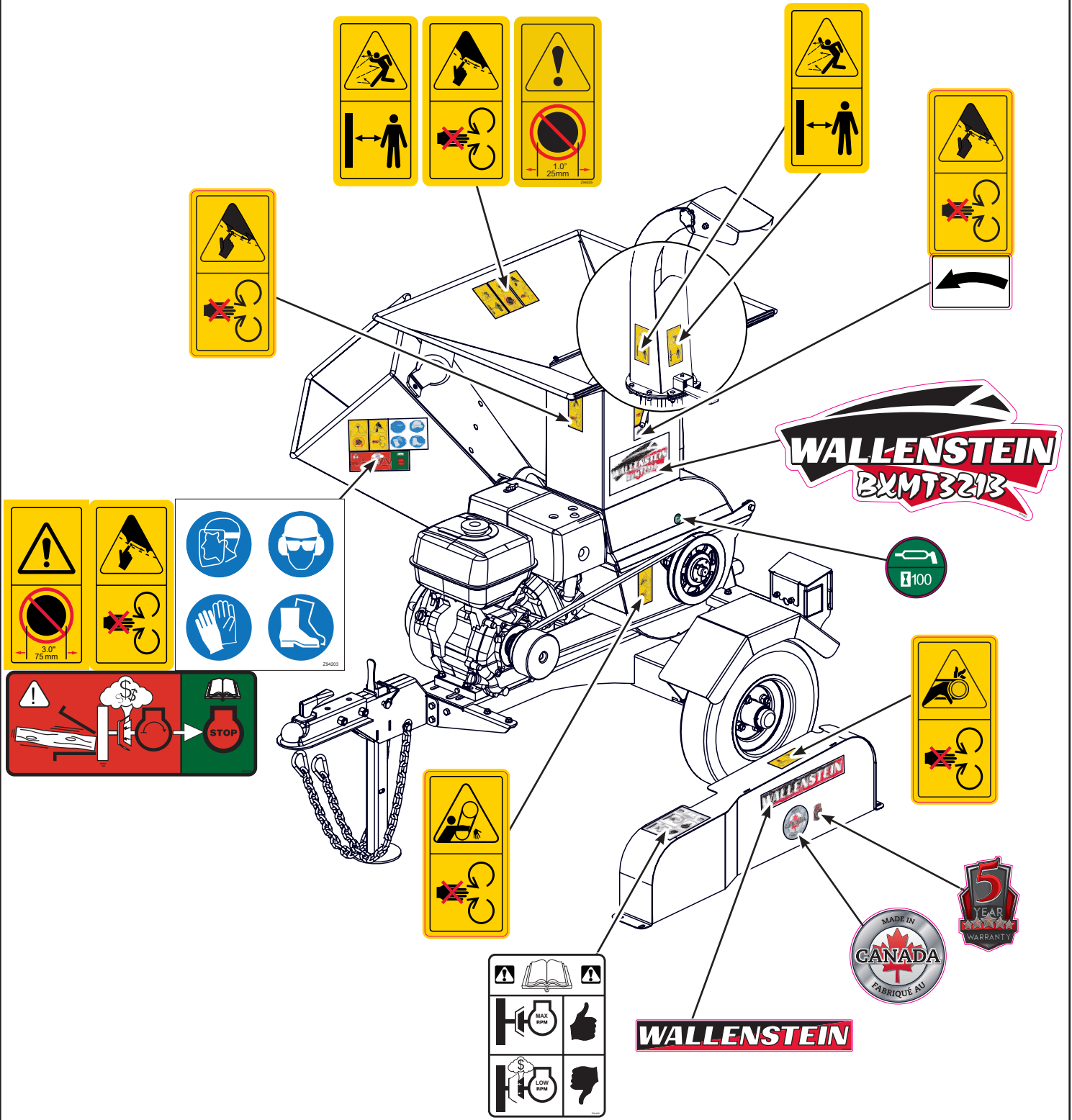

FRONT VIEW

**Decal Layout**

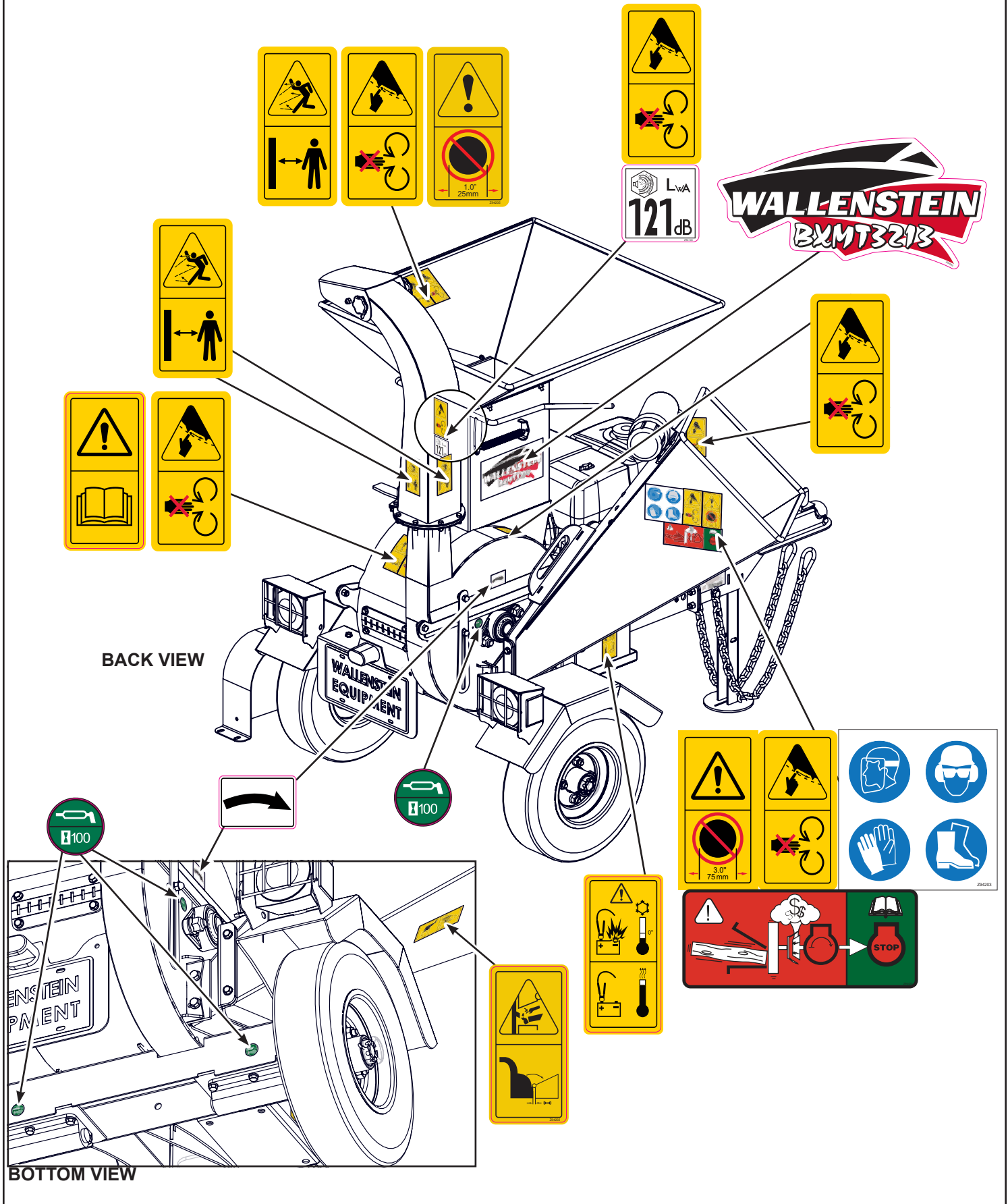

**Accessories**

Call your dealer for pricing and availability



**Ledger Clearance Setting Gauge**

**P/N 1012L269**

An easy and accurate way of setting the critical clearances between the ledger blade and the rotor chipper blade.

## Common Bolt Torque Values

### Checking Bolt Torque

The tables shown give correct torque values for various bolts and capscrews. Tighten all bolts to the torque values specified in the table, unless indicated otherwise. Check tightness of bolts periodically.

**IMPORTANT!** If replacing hardware, use fasteners of the same grade.

**IMPORTANT!** Torque figures indicated in the table are for non-greased or non-oiled threads. Do not grease or oil threads unless indicated otherwise. When using a thread locker, increase torque values by 5%.

 **NOTE:** Bolt grades are identified by their head markings.

### Imperial Bolt Torque Specifications

Bolt Diameter	Torque Value					
	SAE Gr. 2		SAE Gr. 5		SAE Gr. 8	
	lbf•ft	N•m	lbf•ft	N•m	lbf•ft	N•m
1/4"	6	8	9	12	12	17
5/16"	10	13	19	25	27	36
3/8"	20	27	33	45	45	63
7/16"	30	41	53	72	75	100
1/2"	45	61	80	110	115	155
9/16"	60	95	115	155	165	220
5/8"	95	128	160	215	220	305
3/4"	165	225	290	390	400	540
7/8"	170	230	420	570	650	880
1"	225	345	630	850	970	1320



SAE Gr. 2



SAE Gr. 5



SAE Gr. 8

### Metric Bolt Torque Specifications

Bolt Diameter	Torque Value			
	Gr. 8.8		Gr. 10.9	
	lbf•ft	N•m	lbf•ft	N•m
M3	0.4	0.5	1.3	1.8
M4	2.2	3	3.3	4.5
M6	7	10	11	15
M8	18	25	26	35
M10	37	50	52	70
M12	66	90	92	125
M16	166	225	229	310
M20	321	435	450	610
M30	1,103	1 495	1,550	2 100
M36	1,917	2 600	2,700	3 675



8.8



10.9