

# OPERATOR'S MANUAL

---

LXT95 – S/N 2E9US1116FS030006 & Up  
LXT115 – S/N 2E9US1114JS060128 & Up

## LXT95 / LXT115 Log Trailer & Grapple

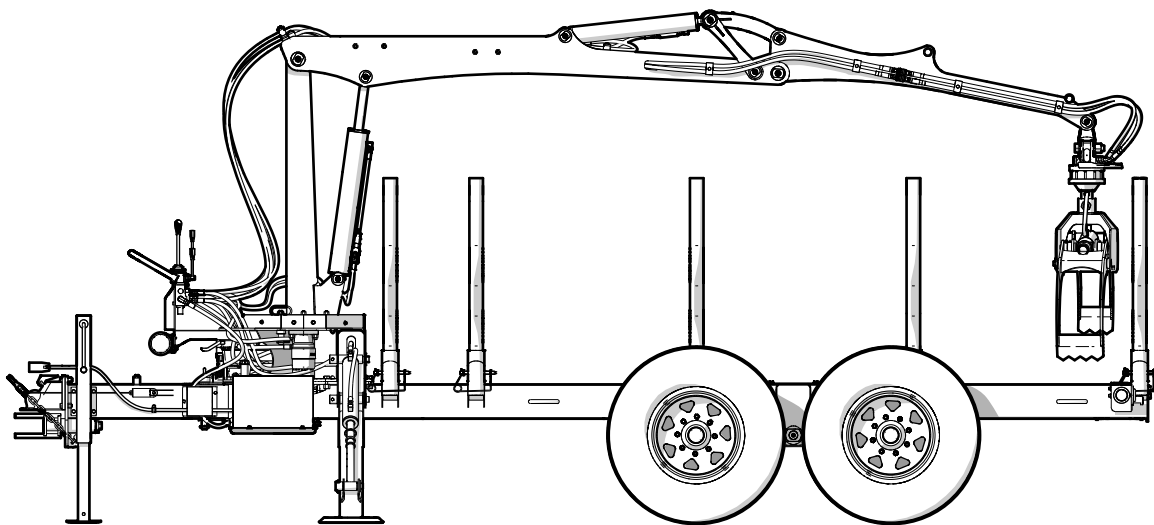

# 1. Foreword

## 1.1 Introduction

### Congratulations on your choice of a Wallenstein Log Loader and Trailer!

This manual covers the Wallenstein LXT95 and LXT115 models designed and manufactured to meet the needs of small timber and landscaping industries. The LXT series are available in many different variations and features.

The log grapples feature a hydraulic power pack, stabilizers, and 360° swivel grapple with bypassing jaws to easily pick up small diameter material. Log trailers have removable, heavy duty bunk posts and back stop.

### Log Grapple / Trailer Combinations

LXT95 Trailer / Grapple
Grapple Boom / Trailer (off road / towable)
Surge Brakes
Hydraulic Sliding Axle
Winch (Option)

LXT115 Trailer / Grapple
Grapple Boom / Trailer (highway towable)
Electric Brakes
Winch (Option)
Hydraulic Articulated Drawbar (Option)

Safe, efficient and trouble-free operation of this Wallenstein product requires that anyone using or maintaining the machine reads and understands the Safety, Operation, Maintenance information contained within this Operator's Manual.

Keep this manual handy for frequent reference and to pass on to new operators or owners. Call your Wallenstein dealer or the Distributor if you need assistance, information or additional copies of the manuals.

Units of measurement in Wallenstein Equipment technical manuals are written as:  
US Customary (SI metric)

### WARNING!

**Do not attempt to start or operate the machine without thoroughly reviewing this manual for safe and proper operation.**

**Always keep this manual with the machine.**

W034

Wallenstein Equipment Inc. • © 2022. All rights reserved.

No part of this work may be copied, reproduced, replaced, distributed, published, displayed, modified, or transferred in any form or by any means except with the prior permission of Wallenstein Equipment Inc.

## Table of Contents

<b>1. Foreword .....</b>	<b>2</b>	<b>6. Operating Instructions .....</b>	<b>34</b>
1.1 Introduction.....	2	6.1 Jobsite Safety .....	34
1.2 Delivery Inspection Report.....	4	6.2 Before Start-up.....	34
1.3 Serial Number Location .....	5	6.3 Machine Break-In .....	35
1.4 Types of Decals on the Machine .....	6	6.4 Pre-start Checks .....	35
<b>2. Safety .....</b>	<b>7</b>	6.5 Engine Oil Level Check .....	36
2.1 Safety Alert Symbol.....	7	6.6 Fuel Level Check .....	36
2.2 Signal Words.....	7	6.7 Starting the Engine .....	37
2.3 Why is SAFETY important?.....	7	6.8 Stopping .....	38
2.4 Safety Rules.....	7	6.9 Load Distribution .....	38
2.5 Equipment Safety Guidelines .....	8	6.10 Loading.....	39
2.6 Safe Condition.....	9	6.11 Unloading and Stacking Logs .....	40
2.7 Safety Training .....	9	6.12 Operating Hints .....	42
2.8 Hydraulic Safety.....	9	6.13 Transporting.....	43
2.9 Welding Safety .....	10	6.14 Storage .....	44
2.10 Tire Safety.....	10	<b>7. Service and Maintenance.....</b>	<b>45</b>
2.11 Gas Engine Safety .....	10	7.1 Fluids and Lubricants .....	45
2.12 Winch Safety.....	11	7.2 Grease Points.....	46
2.13 Grapple Boom Safety.....	12	7.3 Maintenance Schedule .....	50
2.15 Sign-Off Form .....	14	7.4 Engine Air Cleaner .....	51
2.16 Safety Sign Explanations .....	15	7.5 Hydraulic Oil.....	52
2.17 Information Decals .....	18	7.6 LXT95 Surge Brakes.....	54
2.18 Replacing Damaged Safety Signs .....	18	7.7 LXT115 Electric Brakes .....	55
<b>3. Familiarization.....</b>	<b>19</b>	7.8 Winch Accessory .....	56
3.1 Training.....	19	<b>8. Troubleshooting.....</b>	<b>57</b>
3.2 Job Site Familiarization .....	19	<b>9. Specifications .....</b>	<b>58</b>
3.3 Operator Orientation .....	19	9.1 Machine Specifications.....	58
3.4 Machine Components.....	20	9.2 Accessories & Options .....	58
3.5 L400 Log Boom/Grapple Three Point Hitch Adaptor ....	23	9.3 Common Bolt Torque Values .....	59
<b>4. Controls .....</b>	<b>24</b>	9.4 Hydraulic Fitting Torque.....	60
4.1 Operator Console Swivel.....	24	9.5 Wheel Lug Torque .....	60
4.2 Main Directional Control Valve .....	24	<b>10. Product Warranty.....</b>	<b>61</b>
4.3 Hydraulic Power Pack .....	26	<b>11. Alphabetical Index .....</b>	<b>62</b>
4.4 Bunk Posts.....	28		
4.5 Hydraulic Sliding Tandem Axle.....	28		
4.6 Articulated Trailer Tongue.....	29		
4.7 Hydraulic Winch.....	30		
4.8 Braking Systems .....	31		
<b>5. Machine Setup .....</b>	<b>33</b>		

## 1.2 Delivery Inspection Report

### Wallenstein Log Trailer & Grapple

To activate warranty, register your product at: [www.wallensteinequipment.com](http://www.wallensteinequipment.com)

This form must be filled out by the dealer at the time of delivery, then signed by the dealer and customer.

The product manuals have been received by me and I have been thoroughly instructed as to care, adjustments, safe operation, and applicable warranty policy.

I have thoroughly instructed the buyer on the equipment care, adjustments, safe operation and applicable warranty policy and reviewed the manuals.

Customer

Dealer

Address

Address

City, State/Province, ZIP/Postal Code

City, State/Province, ZIP/Postal Code

( )

( )

Phone Number

Phone Number

Contact Name

Model

Serial Number

Delivery date

### 1.2.1 Dealer Inspection Report

- \_\_\_\_\_ Check hydraulic hoses
- \_\_\_\_\_ Check boom and grapple function
- \_\_\_\_\_ All grease points have been lubricated
- \_\_\_\_\_ Boom lock pin is installed
- \_\_\_\_\_ Check wheel lug nuts are properly torqued
- \_\_\_\_\_ Check all fasteners are tight
- \_\_\_\_\_ Check tire pressure
- \_\_\_\_\_ Hitch has retainer is installed
- \_\_\_\_\_ Check bunk posts, back stop
- \_\_\_\_\_ Check function of electric or surge brakes
- \_\_\_\_\_ Test all lights function as intended

\_\_\_\_\_ Test function of adjustable tandem

\_\_\_\_\_ Check trailer jack

#### Power Pack-equipped Models

- \_\_\_\_\_ Check hydraulic hoses
- \_\_\_\_\_ Check Hydraulic reservoir fluid level
- \_\_\_\_\_ Check engine oil, fuel levels. Check engine startup

#### Hydraulic Winch-equipped Models

- \_\_\_\_\_ Test winch function
- \_\_\_\_\_ Check winch rotation direction and speed

### 1.3 Serial Number Location

Always provide the model and serial number of your Wallenstein product when ordering parts or requesting service or other information. The product information plate location is shown in the illustration.

**Record your product Model and Serial Number in the spaces provided below for future reference.**

Record Product Information Here	
<b>Model:</b>	
<b>Serial Number:</b>	

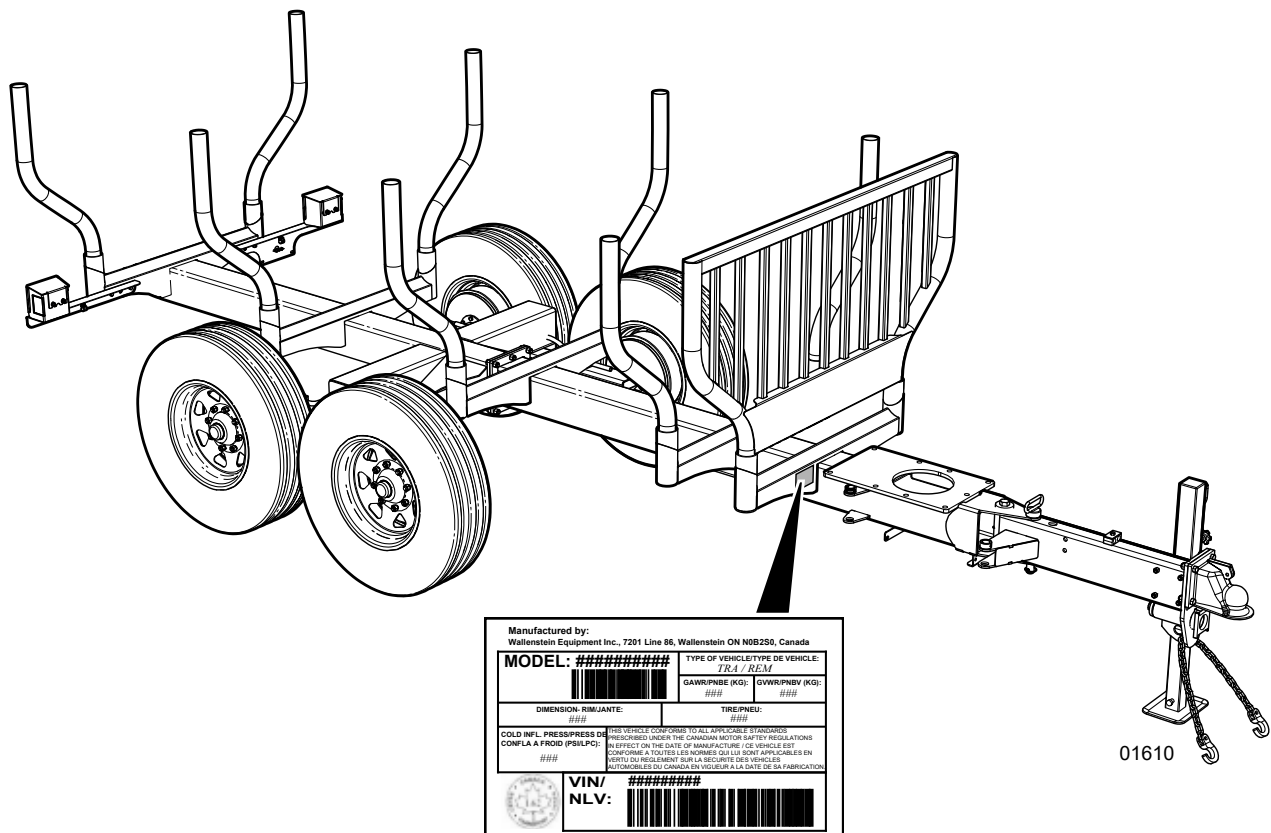
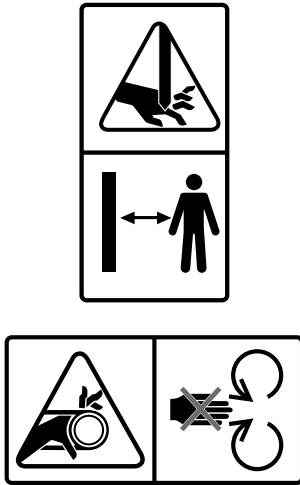

Fig. 1 – Serial Number Plate Location (Typical)

## 1.4 Types of Decals on the Machine

When getting familiar with the Wallenstein product, notice that there are numerous decals located on the machine. There are different types of decals for safety, information, and product identification. The following section explains what they are for and how to read them.

**Safety Decals** are pictorial with a yellow background and generally two panel. They can be either vertical or horizontal.



**Safety Notice Decals** are pictorial with a blue background and generally rectangular with single or multiple symbols. This decal informs what Personal Protective Equipment is required for safe operation.



**Informative Decals** are generally pictorial with a white background and can vary in the number of panels. This type of decal provides additional information to the operator or explains the operation of a control.

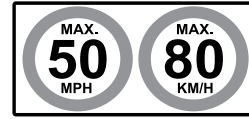

**Product Decals** indicate machine model and serial number, and other important information.

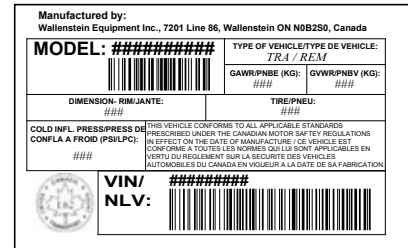

**Maintenance Decals** have a green background and can vary to the number of panels. This decal shows the type of maintenance required and frequency interval.

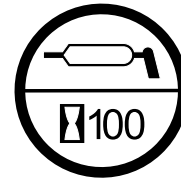

See the section on safety signs for safety decal definitions. For a complete illustration of decals and decal locations, download the parts manual for your model product at [www.wallensteinequipment.com](http://www.wallensteinequipment.com).

## 2. Safety

### 2.1 Safety Alert Symbol

This Safety Alert Symbol means:

**ATTENTION! BE ALERT!**

**YOUR SAFETY IS INVOLVED!**

The Safety Alert Symbol identifies important safety messages on the Wallenstein Product and in the manual.

When you see this symbol, be alert to the possibility of personal injury or death. Follow the instructions in the safety message.



### 2.2 Signal Words

The signal words **DANGER**, **WARNING** and **CAUTION** determine the seriousness level of the warning messages in this manual. The appropriate signal word for each message in this manual has been selected using the following guidelines:

#### **DANGER –**

Indicates an imminently hazardous situation that, if not avoided, **will** result in death or serious injury. This signal word is to be limited to the most extreme situations typically for machine components which, for functional purposes, cannot be guarded.

#### **WARNING –**

Indicates a potentially hazardous situation that, if not avoided, **could** result in death or serious injury, and includes hazards that are exposed when guards are removed. It may also be used to alert against unsafe practices.

#### **CAUTION –**

Indicates a potentially hazardous situation that, if not avoided, **may** result in minor or moderate injury. It may also be used to alert against unsafe practices.

**IMPORTANT** – To avoid confusing equipment protection with personal safety messages, a signal word **IMPORTANT** indicates a situation that if not avoided, could result in damage to the machine.

### 2.3 Why is SAFETY important?

#### Three Big Reasons:

- **Accidents Disable and Kill**
- **Accidents Cost**
- **Accidents Can Be Avoided**

**YOU** are responsible for the SAFE operation and maintenance of your Wallenstein product. **YOU** must make sure that anyone who is going to use, maintain or work around the machine is familiar with the operating and maintenance procedures and related **SAFETY** information contained in this manual. This manual alerts you to all good safety practices that should be used while using your Wallenstein equipment.



**YOU** are the key to safety. Good safety practices not only protect you but also the people around you. Make these practices a working part of your safety program. Be certain that **EVERYONE** using this equipment is familiar with the recommended operating and maintenance procedures and follows all the safety precautions.

**Do not risk injury or death by ignoring good safety practices.**

### 2.4 Safety Rules

- The operator of this machine must be a responsible, physically able person familiar with machinery and trained in this equipment's operation.
- The operator must follow ALL Safety and Operating instructions in this manual. The most important safety device on this equipment is a SAFE operator.



- Provide instructions to anyone else who is going to operate the machine. This equipment is dangerous to anyone unfamiliar with its operation. 
- Review safety related items annually with all personnel who will be operating or performing maintenance.
- Never consume alcohol or drugs while using this equipment. Alertness or coordination can be affected. Consult your doctor about using this machine while taking prescription medications.
- Avoid loose fitting clothing, loose or uncovered long hair, jewelry, and loose personal articles. These can get caught in moving parts. Jewelry may also ground a live circuit.
- Keep a first-aid kit available for use should the need arise and know how to use it. 
- Inspect and secure all shields before starting.
- Keep a fire extinguisher available for use should the need arise and know how to use it. 
- Do not expect a person who has not read and understood all use and safety instructions to operate the machine. An untrained operator is not qualified and exposes himself and bystanders to possible serious injury or death. It is the owner's responsibility to the operator to ensure familiarity and understanding of the machine.
- Do not allow riders during transport.
- Do not risk injury or death by ignoring good safety practices.
- Stay a minimum 20 ft (6 m) away from power lines. Power lines as well as the surrounding air space which insulates the line can be hazardous. Electricity can arc or jump through the insulating air space. The higher the voltage, the more likely it is for an arc to occur.
- Never swing a load if the operator's line of sight is obstructed. Do not lift it higher than is necessary to provide unobstructed vision for the equipment operator.
- Never use the machine until the operators have been adequately trained in the safe operation of the machine and have read and completely understand:
  - Safety, operation and feature sections of this manual
  - Each of the safety messages found on the safety signs on the machine.
  - Engine operator's manual (as equipped)

- Extend stabilizers to support and steady the trailer and boom during loading or stacking. Keep the trailer attached to the tow vehicle.
- Always wear appropriate PPE. This equipment includes but is not limited to the following:
  - A hard hat
  - Heavy gloves
  - Hearing protection
  - Protective shoes with slip resistant soles
  - Protective glasses, goggles, or face shield
- Train all operators to be familiar with equipment's operation. The operator should be a responsible, properly trained and physically able person familiar with machinery. If the elderly are assisting with work, their physical limitations need to be recognized and accommodated.
- Wear hearing protection on a full-time basis. Prolonged exposure to loud noise may cause permanent hearing loss! 
  - Noise over 85 dB on a long-term basis can cause severe hearing loss.
  - Noise over 90 dB adjacent to the Operator over a long-term basis may cause permanent, total hearing loss.
- When there are two or more operators, review and understand a system of hand signals.
- Keep bystanders away at a safe distance at least 20 ft (6 m) from stacking zone. Mark the zone with safety cones.
- Determine a safe work area / trailer location:
  - Area must be clear of stones, branches or hidden obstacles that might cause a tripping, hooking or snagging hazard.
  - Ground should be firm and level.
- Be aware of overhead hazards: branches, cables, electrical wires.
- Use only in daylight or good artificial light.
- Be sure machine is properly stationed, adjusted and in good operating condition.
- Ensure that all safety shielding and safety signs are properly installed and in good condition.
- If fuel is on site, store it well away from the material pile .
- Perform the **Pre-start Checks** procedure before starting work (see *page 35*).

## 2.5 Equipment Safety Guidelines

- Keep all shields in place. If shield removal becomes necessary for repairs, replace it prior to use.



- Replace any safety sign or instruction sign that is not readable or is missing. Location and explanation of safety signs are on page 15.
- Do not modify the equipment in any way. Unauthorized modification may result in serious injury or death and may impair the function and life of the equipment. Unapproved modifications void warranty.
- Never exceed the limits of machinery. If the ability to do a job, or to do it safely is in question – **DO NOT TRY IT.**
- LXT95 Log Loader / Trailers are not intended for use or transport on public roadways. For more information, see *Transporting on page 43.*

## 2.6 Safe Condition

Throughout this manual, we talk about a 'Safe Condition'. What this means is setting the machine in a state that makes it safe to service or repair.

**Place the machine in a Safe Condition before performing any service, maintenance work or storage preparation by performing the following:**

Safe Condition
<ul style="list-style-type: none"><li>– Grapple is closed and resting on trailer</li><li>– Boom lock pin is installed</li><li>– Fuel valve is turned off (power pack equipped)</li><li>– Trailer load is secure</li><li>– Tow vehicle parking brake is applied. Engine stopped</li></ul>

## 2.7 Safety Training

Safety is a primary concern in the design and manufacture of Wallenstein products. Unfortunately, efforts to provide safe equipment can be wiped out by a single careless act.

- Learn the controls and how to stop the machine quickly in an emergency. A person who is not aware of operation and safety instructions is not qualified to use the machine.
- Make sure every operator:
  - Reads and understands the operator's manual
  - Is instructed in safe and proper use of the equipment
  - Understands and knows how to perform the Safe Condition procedure
- Train all new personnel and review instructions frequently with existing workers. Be certain only a properly trained, physically able person uses the machine. An untrained operator can cause possible serious injury or death.

## 2.8 Hydraulic Safety

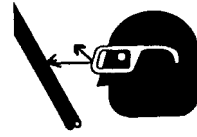
- Make sure that all the components in the hydraulic system are kept in good condition and clean.
- Before applying pressure to the system, make sure all components are tight, and that lines, hoses and couplings are not damaged. 
- Do not attempt any makeshift repairs to the hydraulic lines, fittings or hoses by using tapes, clamps or cements. The hydraulic system operates under extremely high pressure. Such repairs can fail suddenly and create a hazardous, unsafe condition.
- Wear proper hand and eye protection when searching for a high-pressure hydraulic leak. Use a piece of wood or cardboard as a backstop instead of hands to isolate and identify a leak. 
- If injured by a concentrated high-pressure stream of hydraulic fluid, seek medical attention immediately. Serious infection or toxic reaction can develop from hydraulic fluid piercing the skin surface.
- Relieve pressure in the hydraulic circuit before working on it.

## 2.9 Welding Safety

- Welding repairs are to be performed by a trained welder with proper service instructions. Know the material to be welded and select the correct welding procedure and materials (electrodes, rods, wire) that provide a weld metal strength equivalent to the parent material.
- Work with extra care when welding, grinding or torch cutting near flammable objects.
- Welding on painted surfaces releases dangerous fumes and results in a poor weld joint that can result in failure and potential accidents. Always remove paint from areas to be welded.
- Heated paint gives off poisonous gases. Therefore, paint must be removed from an area with a radius of at least 4" (10 cm) before carrying out welding, grinding or gas cutting. In addition to the health hazard, the weld is of inferior quality and strength if the paint is not removed.

### Methods and precautionary measures when removing paint:

Blasting—use respiratory protective equipment and protective goggles.

Paint remover or other chemicals—use a portable air extractor, respiratory protective equipment and protective gloves.

Grinding—use a portable air extractor, respiratory protective equipment and protective gloves and goggles.

## 2.10 Tire Safety

- Failure to follow proper procedures when mounting a tire on a wheel or rim can produce an explosion which may result in serious injury or death.
- Do not attempt to mount a tire unless you have the proper equipment and experience to do the job.
- Have a qualified tire dealer or repair service perform required tire maintenance.
- When replacing worn tires, make sure they meet the original tire specifications. Never undersize.

## 2.11 Gas Engine Safety



**Before starting the engine, review the safety, operating, and maintenance instructions in the engine manual.**

W019

- **DO NOT** place hands or feet near moving or rotating parts.
- **DO NOT** store, spill, or use gasoline near an open flame, or devices such as a stove, furnace, or water heater which use a pilot light or devices which can create a spark.
- **DO NOT** refuel indoors where area is not well ventilated. Outdoor refueling is preferred.
- **DO NOT** refuel while engine is running. Stop engine and allow to cool for five minutes before refueling. Store fuel in approved safety containers.
- **DO NOT** remove fuel tank cap while engine is running.
- **DO NOT** operate engine if gasoline is spilled. Move machine away from the spill and avoid creating any ignition until gasoline has evaporated.
- **DO NOT** smoke while filling fuel tank.
- **DO NOT** choke carburetor to stop engine. Whenever possible, gradually reduce engine speed before stopping.
- **DO NOT** tamper with engine governor springs, governor links or other parts which may increase the governed speed as set by the original equipment manufacturer. Engine overspeed can result in injury.
- **DO NOT** check for spark with spark plug or spark plug wire removed.
- **DO NOT** crank engine with spark plug removed. If engine is flooded, crank until engine starts.
- **DO NOT** strike flywheel with a hard object or metal tool as this may cause flywheel to shatter in operation. Use proper tools to service engine.
- **DO NOT** operate engine without a muffler. Inspect periodically and replace if necessary. If engine is equipped with a muffler deflector, inspect periodically and replace if necessary with correct deflector.
- **DO NOT** operate engine with an accumulation of grass, leaves, dirt or other combustible materials in the muffler area.
- **DO NOT** use this engine on any forest covered, brush covered, or grass covered unimproved land unless a spark arrester is installed on the muffler. The arrester must be maintained in effective working order by the operator. In the state of California, the above is required by law (Section 4442 of the California Public Resources Code). Other states may have similar laws. Federal laws apply on federal land.
- **DO NOT** touch hot muffler, cylinder or fins because contact may cause burns.
- **DO NOT** run engine with air cleaner or air cleaner cover removed.

- **DO NOT** run engine in an enclosed area. Exhaust gases contain carbon monoxide, which is an odorless and deadly gas.

## Be sure to:

- Remove the wire from the spark plug when servicing the engine or equipment to prevent accidental starting. Disconnect the negative wire from the battery terminal if equipped.
- Keep cylinder fins and governor parts free of grass and other debris which can affect engine speed.
- Examine muffler periodically to be sure it is functioning effectively. A worn or leaking muffler should be repaired or replaced as necessary.
- Use fresh gasoline. Stale fuel can gum carburetor and cause leakage.
- Check fuel lines and fittings frequently for cracks or leaks. Replace if necessary.
- Check that the winching trail is clear of obstructions so logs can be winched in easily.
- Never exceed a winching angle of  $\pm 25^\circ$  from the centerline of the machine. If unsure of winch angle, reposition machine or use a snatch block. Whenever possible winch in line with the machine.

## 2.12 Winch Safety

This information pertains to the winch accessory, if equipped. Refer to winch manual included with your machine for further information.

### WARNING!

**Synthetic rope that fails under tension can snap back with great force causing injury or death. Avoid sudden jerks, quick starts or stops. Start slowly and smoothly. Replace if kinked, badly frayed, has knots, cuts, or broken strands.**

W095

- Never stand in line with the path of a rope under tension. Stand to the side to activate the winch. If a rope breaks under tension, it can snap back in an unpredictable direction with great force. The recoil may cause injury or death to a person in its path.
- Always keep hands clear of winch rope, hook loop, hook and fairlead opening during installation, operation, and when spooling in or out. Never touch winch rope or hook while under tension or under load.
- Always be certain the anchor you select can withstand the load and the strap or chain cannot slip.
- Never engage or disengage clutch if winch is under load, winch rope is in tension or drum is moving.
- Check rope condition before using winch. Rope may break during operation if knotted, has broken strands, or sharp kinks. Replace rope if damaged. Do not touch rope during operation.
- Do not allow anyone within 20 ft (6 m) of logs when winching. Logs can roll in unpredictable ways.
- Wind the rope under load. Rope does not wind in properly with no load.

## 2.13 Grapple Boom Safety

### Operator Safe Area

In certain cases where the boom is fully retracted and handling an 8 ft (2.4 m) log, it is possible to create a collision hazard with the operator at the control station. Follow these important points to keep operators and workers safe from potential hazards.

- Create a 90° operator safety zone based on the position of your work station, and material stack. Never move the grapple or material into the operator safe zone.
- Rotate the operator console so it is opposite the work area. If work area is on the left of the trailer, position the control station on the right of the trailer.
- Always be aware of the position of the boom and material being handled.
- Always be aware of overhead hazards, modify your work zone to take these hazards into account:
  - Telephone lines
  - Tree branches
  - Roof overhang
  - Wash lines, ropes or cables
  - Power lines – stay a minimum 20 ft (6 m) away.
- A Safe Area must be designated for workers on foot near this equipment.
- The boundaries of a designated Safe Area must be communicated to all workers within and near the Work Zone.

### Work Zone

Injury may occur from heavy material falling / dropping or material on a rotating boom creates a collision hazard if workers or bystanders are inside the working zone. Follow these important points to keep workers and bystanders safe from potential hazards:

- A *Work Zone* includes any area where work with this grapple is done and can include the traveled portion of a road if being used as a landing.
- Create a 20 ft (6 m) radius work zone perimeter, clearly marked with safety cones.
- Workers and bystanders should never approach the grapple while in operation without first signaling the operator.
- Work being done in a Work Zone in a forestry operation must be planned and the work area must be located, constructed, maintained, and operated to ensure that:
  - Logs can be moved safely in the area
  - Log piles and equipment used to handle the logs do not become unstable or otherwise create a hazard
  - Workers can work in locations clear of moving logs and equipment
  - Workers are not exposed to incoming or runaway logs or other debris
  - The area is kept free from buildup of bark and other debris to the extent that it would pose a risk to workers
  - An effective method of dust control is used and maintained
- Log piles must, to the extent practicable, be located on stable and relatively level ground.
- Log piles must not be higher than the safe operating reach of the excavator being used to handle the logs.

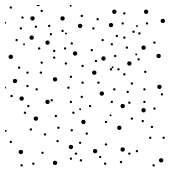

### 1. Operator Safe Area

Create a Safe Area for the operator and coworkers based on the work station and boom position. The area outside of the Work Zone is designated a Safe Area for coworkers.



### 2. Work Zone

Injury may occur from heavy material falling / dropping in this area. Material on a rotating boom creates a collision hazard if workers or bystanders are inside the Work Zone.

Place safety cones around the area to warn others.

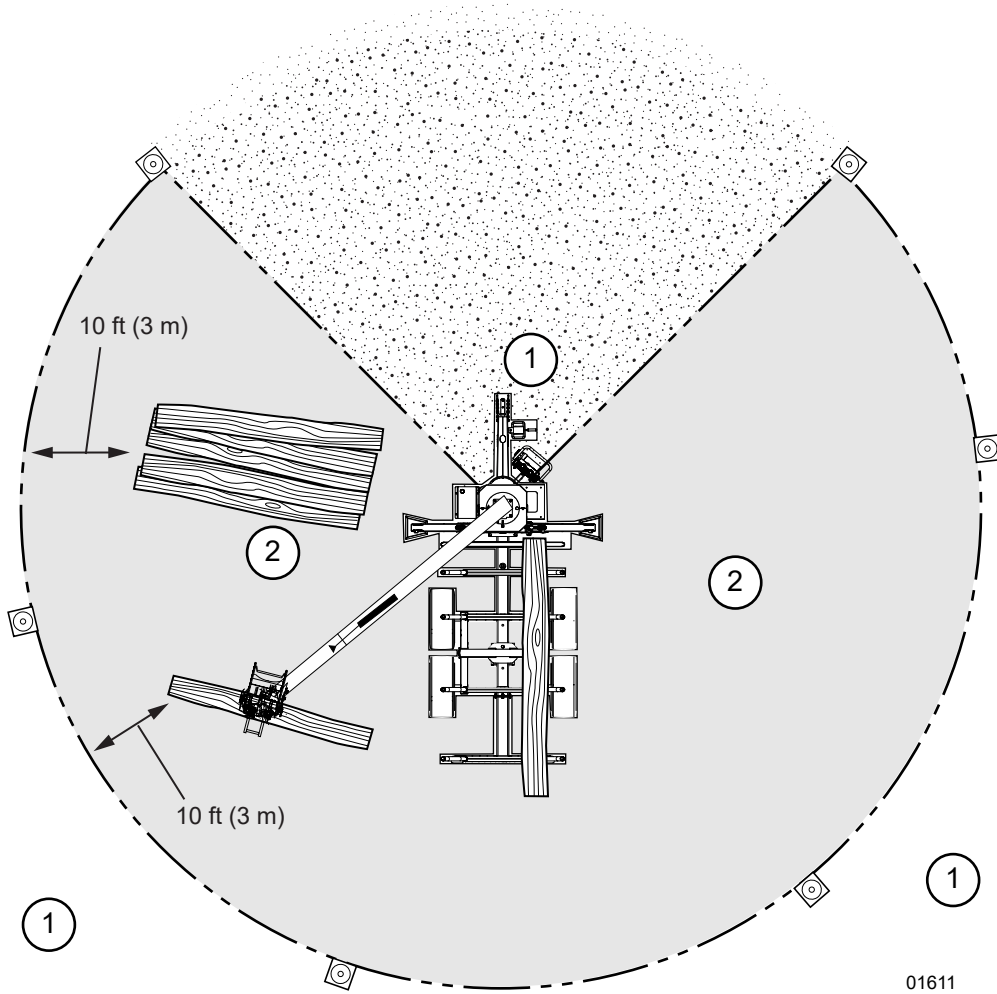

Fig. 2 – Operator Work Station Kept Opposite Work Area

## 2.15 Sign-Off Form

Anyone using this machine must read and thoroughly understand all Safety, Operation and Maintenance information in this manual. An untrained operator should never use this machine.

To help document this training, the sign-off sheet provided below can be used.

Make periodic reviews of Safety and Operation a standard practice for all operators. Review again at the startup of every season.

The design and manufacture of this product conforms to relative provisions in the following standards:

ASABE S318 Safety for Agricultural Field Equipment

ISO 3600 Operator's Manual – Machinery for Agriculture, Forestry & Lawn Equipment

Sign-off Form		
Date	Owner	Employee

## 2.16 Safety Sign Explanations

The top (or left-hand) panel on the decal shows the potential hazard.

The bottom (or right-hand) panel shows how the hazard is avoided.

Practicing good safety means becoming familiar with safety signs and warnings and being aware of the situations that require alertness.

**Think SAFETY! Work SAFELY!**

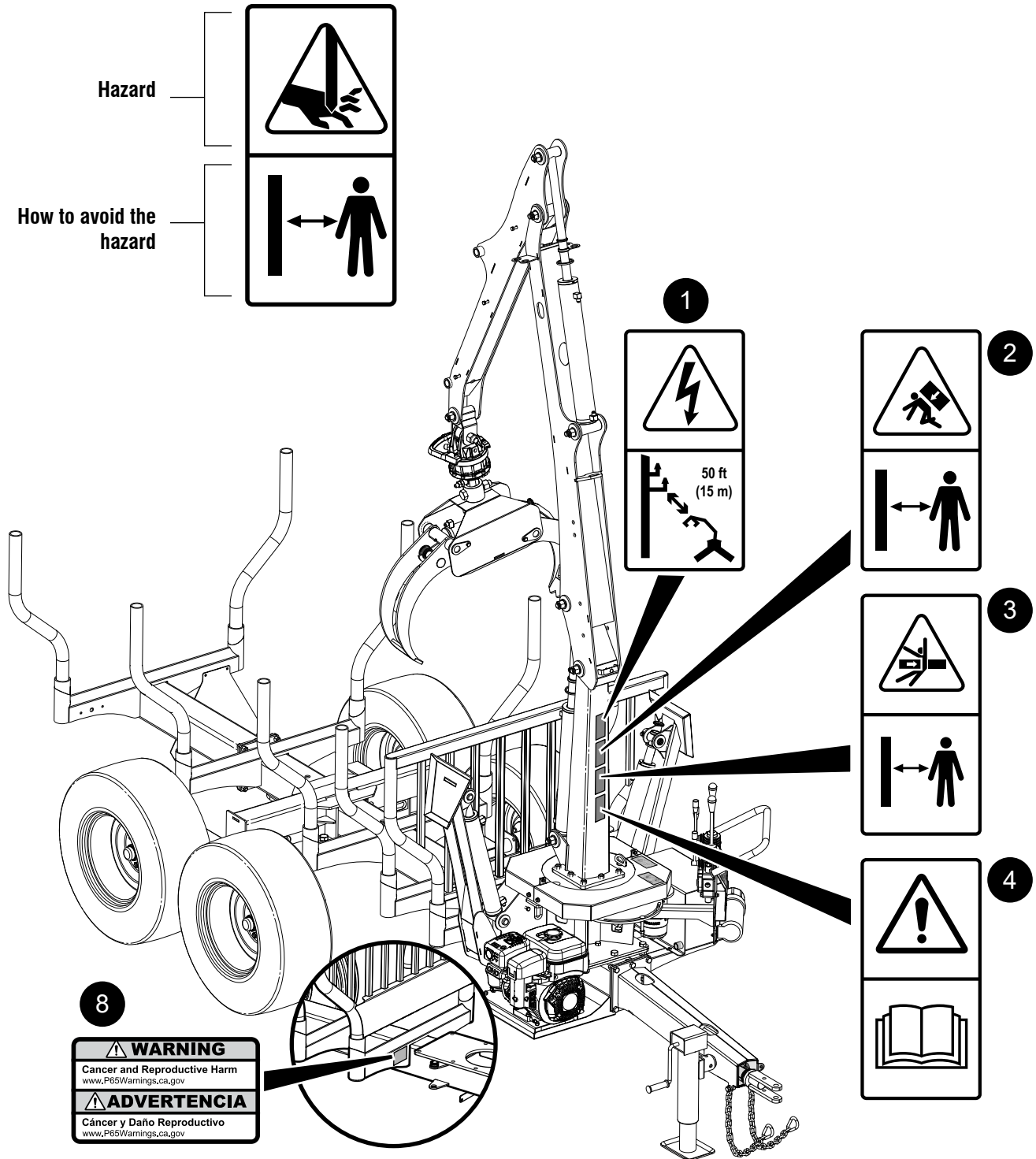

01839

Fig. 3 – Safety Decal Locations (LXT95 model shown, however LXT115 is same)

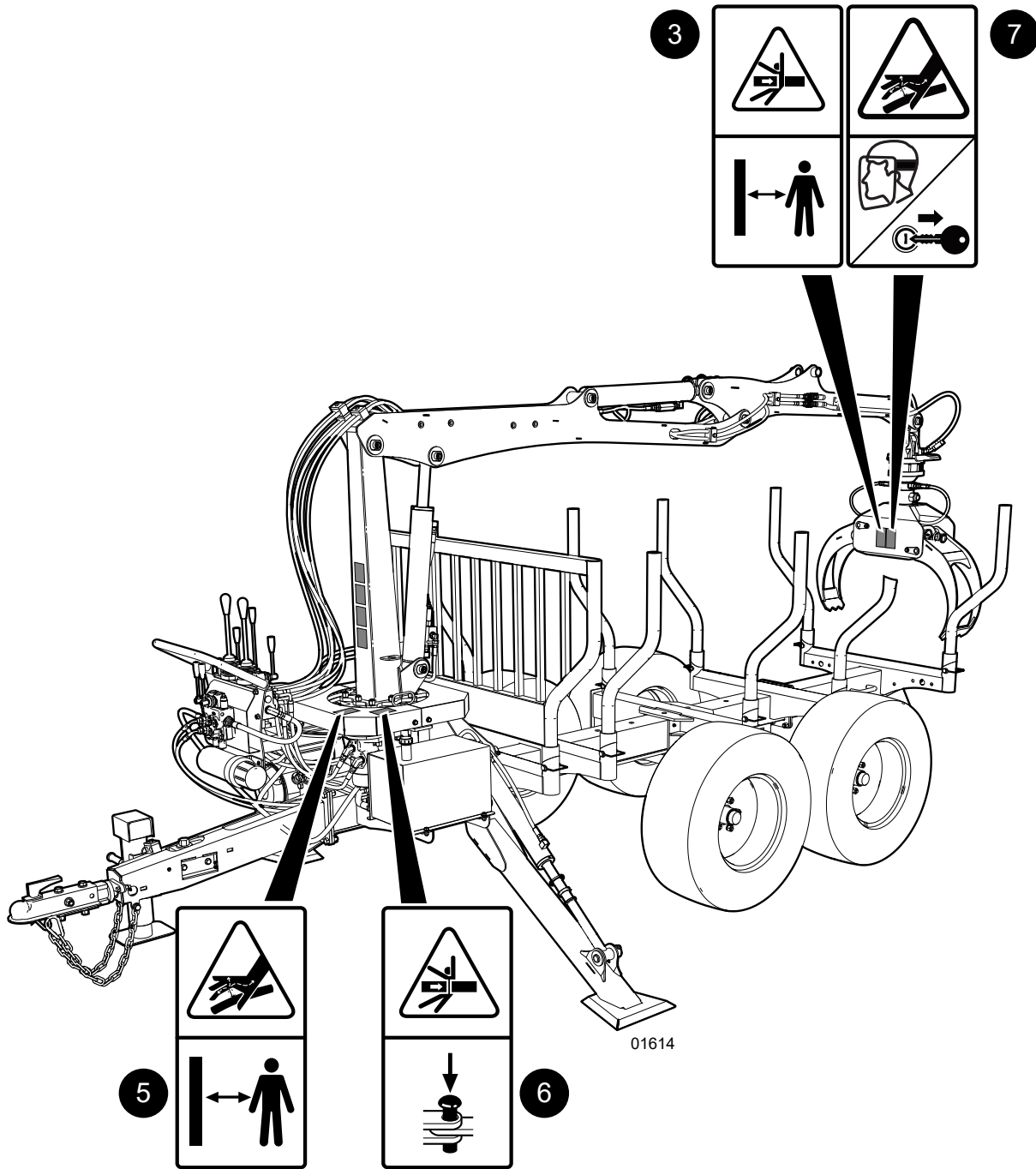

Fig. 4 – Safety Decal Locations (LXT95 model shown, however LXT115 is same)



### 1. WARNING!

**Serious injury or death from electrocution could occur!**

Stay 50 ft (15 m) or more away from overhead electrical cables. Electrocution is possible without direct contact (arcing).

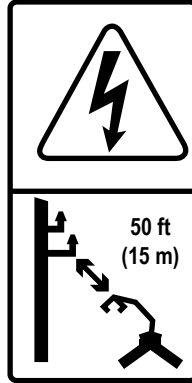

### 4. CAUTION!

**Refer to the operator's manual. Read ALL operating instructions in the manual. Learn the meaning of ALL safety signs on the machine before operating it!**

The best safety feature is an informed operator.

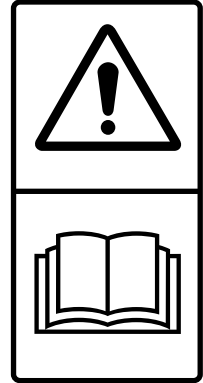

### 2. WARNING!

**Risk of injury from collision with material in the grapple resulting in crushing or impact injuries!**

Always be aware of the boom position and material in the grapple. Keep workers and bystanders clear.



### 5. WARNING!

**Hydraulic fluid under pressure! Risk of high-pressure fluid being injected under the skin!**

Never check for leaks with your hand. Use a piece of wood or cardboard instead. Keep clear of oil leaks that are under pressure.



### 3. WARNING!

**Risk of injury from pinch hazards!**

Be aware of the position of the boom and grapple to prevent injury from moving parts.

Be aware of boom and stabilizer position as control panel moves with rotating boom.



### 6. WARNING!

**Risk of collision hazard with an unsecured boom!**

Install boom lock pin before transporting to keep boom secured.

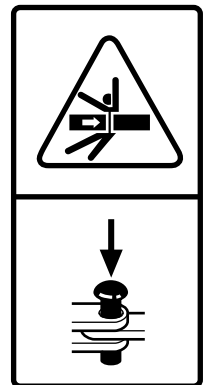

### 7. Caution!

Hydraulic fluid under pressure. In the event of a leak, shut machine down. Do not check for leaks with bare hands. Wear proper hand and eye protection when searching for a high-pressure hydraulic leak.



**IMPORTANT!** If parts are replaced that have safety signs on them, new signs must be applied. Safety signs must always be replaced if they become damaged, are removed, or become illegible.

Safety signs are included in the product decal kit available from your authorized dealer. Decals are not available separately.

### 8. Warning!

**Risk of cancer or reproductive harm.**



The machine materials contain chemicals or machine operation may produce gases or dust that are identified by the state of California as causes of cancer, birth defects, or other reproductive harm.

This warning is required by the state of California, USA to comply with Proposition 65: the Safe Drinking Water and Toxic Enforcement Act of 1986.

## 2.18 Replacing Damaged Safety Signs

Replace any safety sign that is damaged or missing. If a safety sign is attached to a part that is replaced, install a safety sign on the replacement part. Replacement safety signs are available from your authorized distributor, dealer parts department, or Wallenstein Equipment.

### Procedure

Installation area must be clean and dry. Make sure the surface is free of grease or oil. Ambient temperature must be above 50 °F (10 °C).



*Determine exact position before removing the backing paper on the decal.*

1. Peel the decal off the backing sheet.
2. Align the decal with an edge on the machine if possible.
3. Starting on one edge, carefully press the center of the exposed sticky backing in place, smoothing it out as you work from one side to the other.
4. Use a squeegee, credit card or similar to smooth it out. Work from one end of the decal to the other end.

Small air pockets can be pierced with a pin and smoothed out using the piece of sign backing paper.

## 2.17 Information Decals

### Tie Down Point

This decal indicates a tie-down point on the trailer frame.

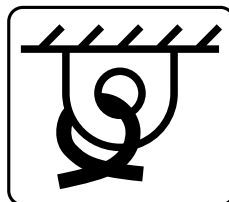

### Recommended Speed Limit

This decal indicates the maximum recommended highway speed of 50 mph (80 km/h) for this trailer.

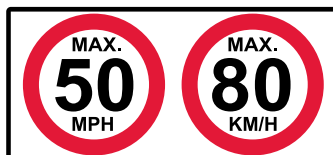

## 3. Familiarization

### 3.1 Training

Each operator must be trained in the proper set-up and operating procedures prior to being allowed to operate the machine.

1. Review control location, function and movement directions.
2. Move the unit to a large open area to allow the operator to become familiar with control function and machine response.
3. When a new operator is familiar and comfortable with the machine, they can proceed with the work. Do not allow untrained operators to use the machine. They can endanger themselves and others or damage property and the machine.

### 3.2 Job Site Familiarization

It is the responsibility of the operator to be thoroughly familiar with the work site prior to starting. Prevent the chance or possibility of problems or accidents by not being in the situation to start with. Some items the operators should check include but are not limited to:

1. Avoid close or cramped work spaces. Be sure there is sufficient space and clearance for machine operation.
2. Organize the working area to minimize work cycles.
3. Position the machine so prevailing winds blow engine exhaust fumes away from operator's station.

### 3.3 Operator Orientation

**IMPORTANT!** The directions for left-hand, right-hand, backward and forward mentioned throughout this manual are determined when sitting in the tractor seat, facing the direction of forward travel.

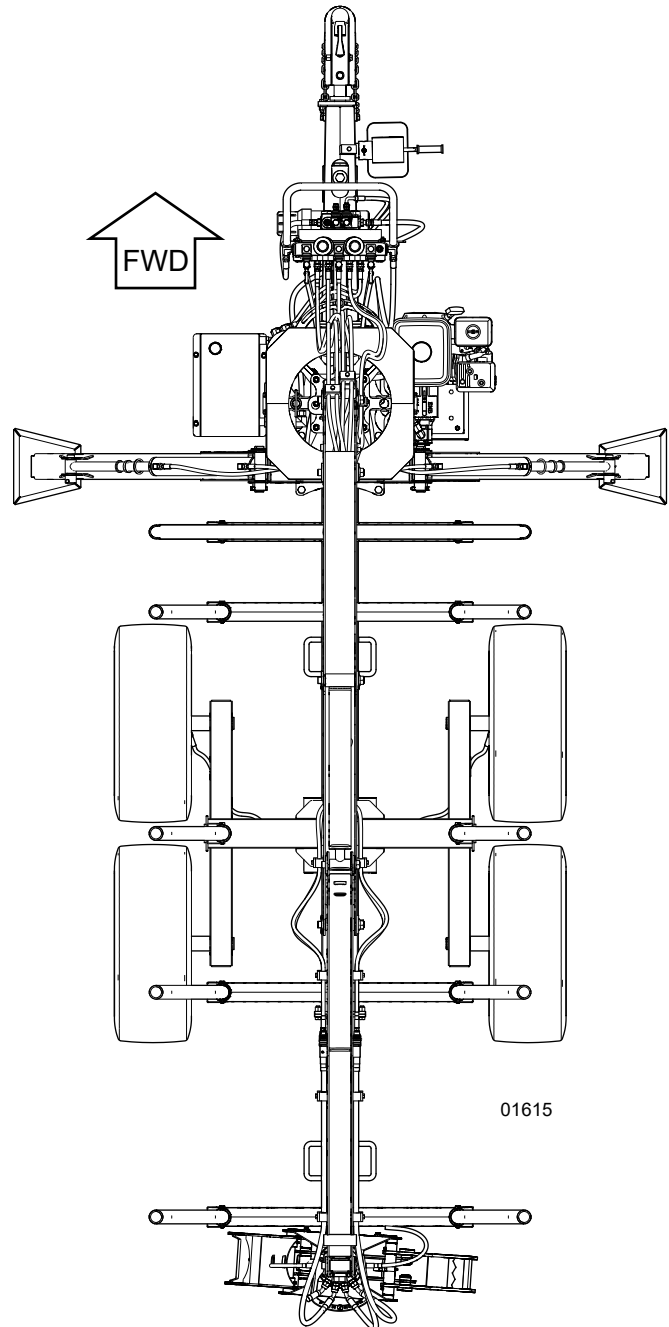

### 3.4 Machine Components

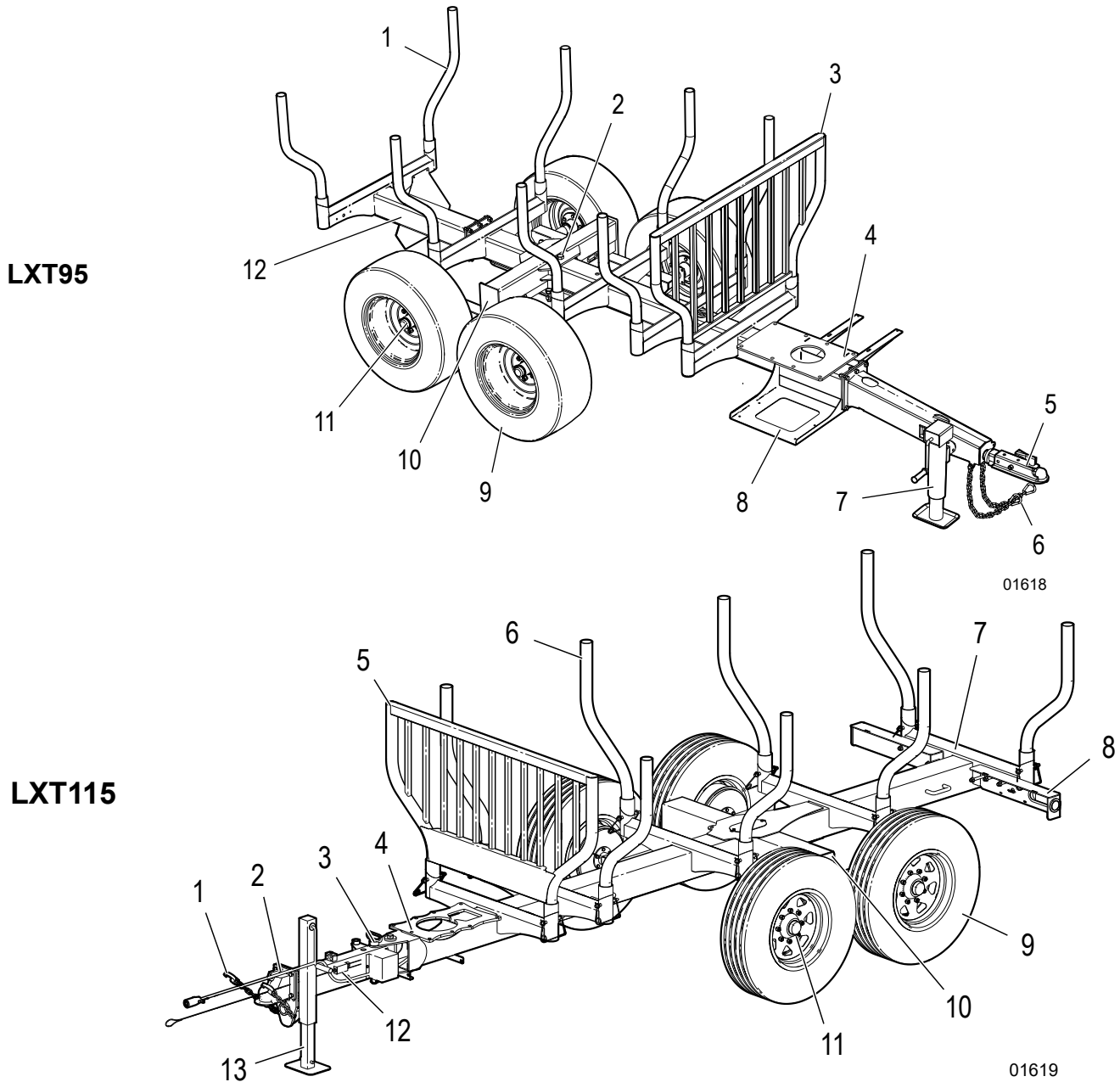

Fig. 5—LXT Trailers

**LXT95**

- 1. Bunk Posts—Removable, Self-centering
- 2. Sliding Axle (Hydraulic)
- 3. Safety Back Guard
- 4. Boom / Grapple Mount
- 5. Clevis Hitch
- 6. Safety Chains
- 7. Swivel Jack
- 8. Power Pack Mount
- 9. 27 x 10.5 x 15 – 8 ply Tires
- 10. Walking Beam Axle
- 11. Hydraulic Surge Brakes
- 12. Trailer Bed

**LXT115**

- 1. Safety Chains
- 2. Hitch Coupler
- 3. Hydraulic Articulated Drawbar (Option)
- 4. Boom / Grapple Mount
- 5. Safety Back Guard
- 6. Bunk Posts—Removable, Self-centering
- 7. Trailer Bed
- 8. Highway Lights
- 9. ST235-80R16 LRE Tires
- 10. Walking Beam Axle
- 11. Electric Brakes
- 12. Trailer Breakaway Switch
- 13. Drop Leg Jack

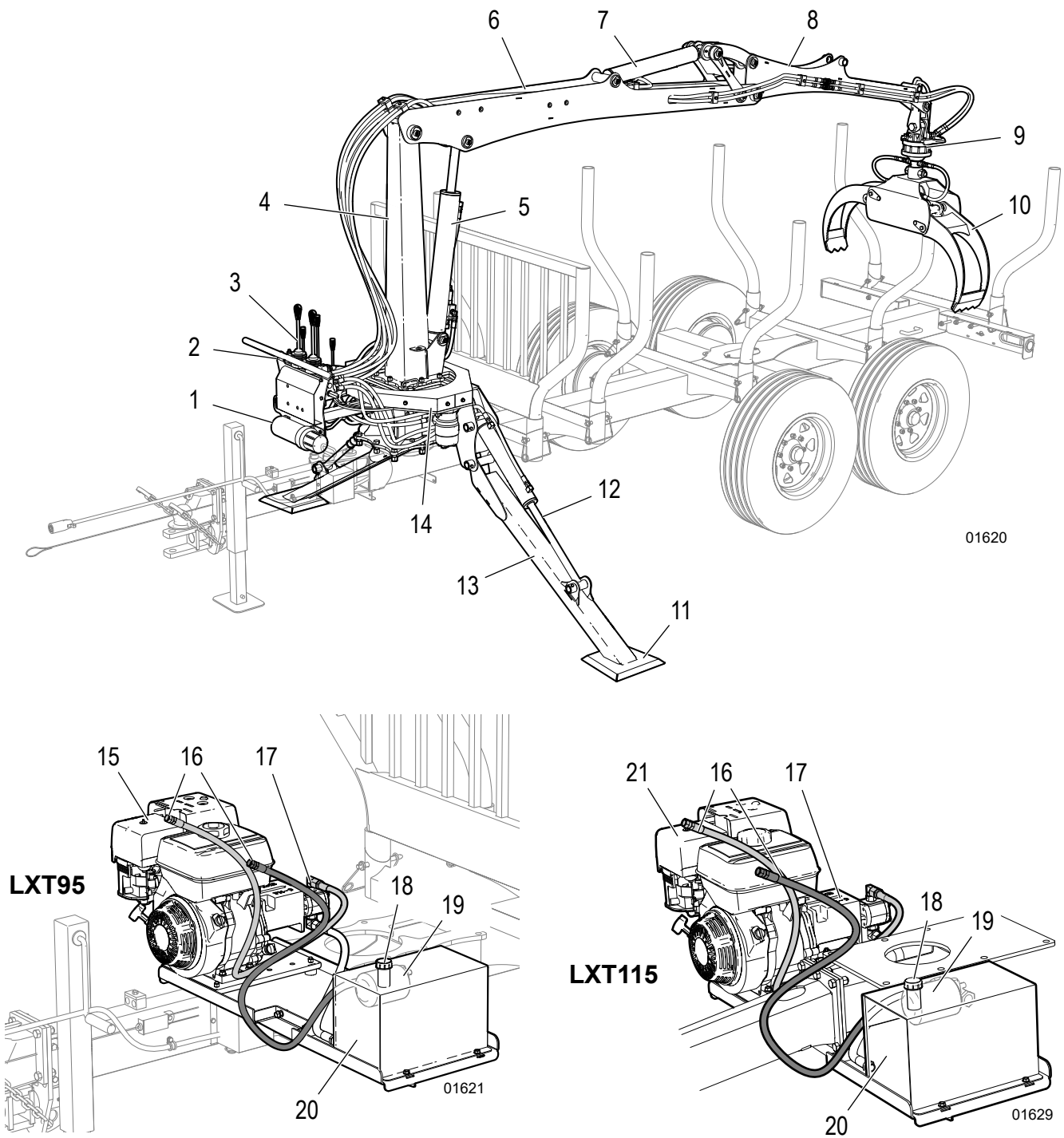

**Fig. 6—LXT Log Boom, Grapple, and Power Pack**

- |                             |                                      |  |
|-----------------------------|--------------------------------------|--|
| 1. Operator's Manual Tube   | 9. Rotator                           | 17. Hydraulic Gear Pump                            |
| 2. Operator Control Station | 10. Grapple                          | 18. Filler Cap / Dipstick                          |
| 3. Main Control Valve       | 11. Stabilizer Foot                  | 19. Return Filter                                  |
| 4. Main Tower               | 12. Stabilizer Cylinder              | 20. Hydraulic Oil Reservoir—4.6 US gal<br>(17.5 L) |
| 5. Main Boom Cylinder       | 13. Stabilizer                       | 21. Honda® GX270 (LXT115)                          |
| 6. Main Boom                | 14. Slew Assembly                    |  |
| 7. Dipper Boom Cylinder     | 15. Honda® GX200, Rope Start (LXT95) |  |
| 8. Dipper Boom              | 16. Pressure and Return Lines        |  |

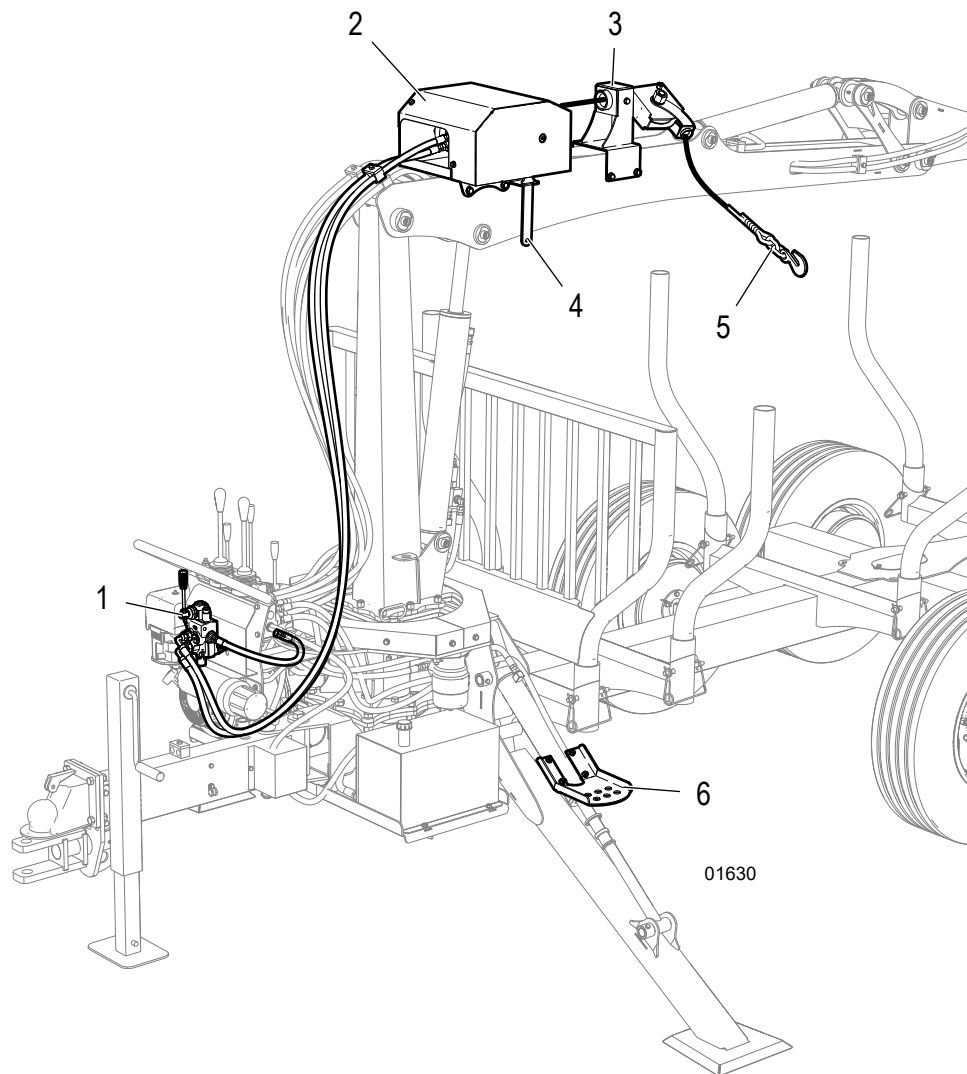

**Fig. 7**—Hydraulic Winch Option

1. Control Valve
2. Two-speed Winch
3. Top Pulley and Cable Guide
4. Winch Clutch/Speed Select Lever
5. Synthetic Winch Rope with Grab Hook
6. Access Step

### 3.5 L400 Log Boom/Grapple Three Point Hitch Adaptor

#### (Option)

The L400 Log Grapple Three-point Hitch Adapter permits mounting the log boom/grapple on the back of a tractor. The category II three-point hitch adaptor has a mounting plate for the boom assembly and a tow bar for your trailer. Hydraulic supply from the tractor powers the boom and grapple.

The L400 adapter can mount either the LXT95 or LXT115 grapple boom. The L400 / LXT95 combination requires a minimum 40 hp and the LXT115 combination requires 60 hp.

Weights or a loader are required on the front of the tractor to balance the grapple boom, as well as provide added stability.

To accommodate the wide variety of three-point hitch configurations available, the L400 adapter features dual height lower link arm brackets, fully adjustable top link tie back bars, and four-position tie back bracket.

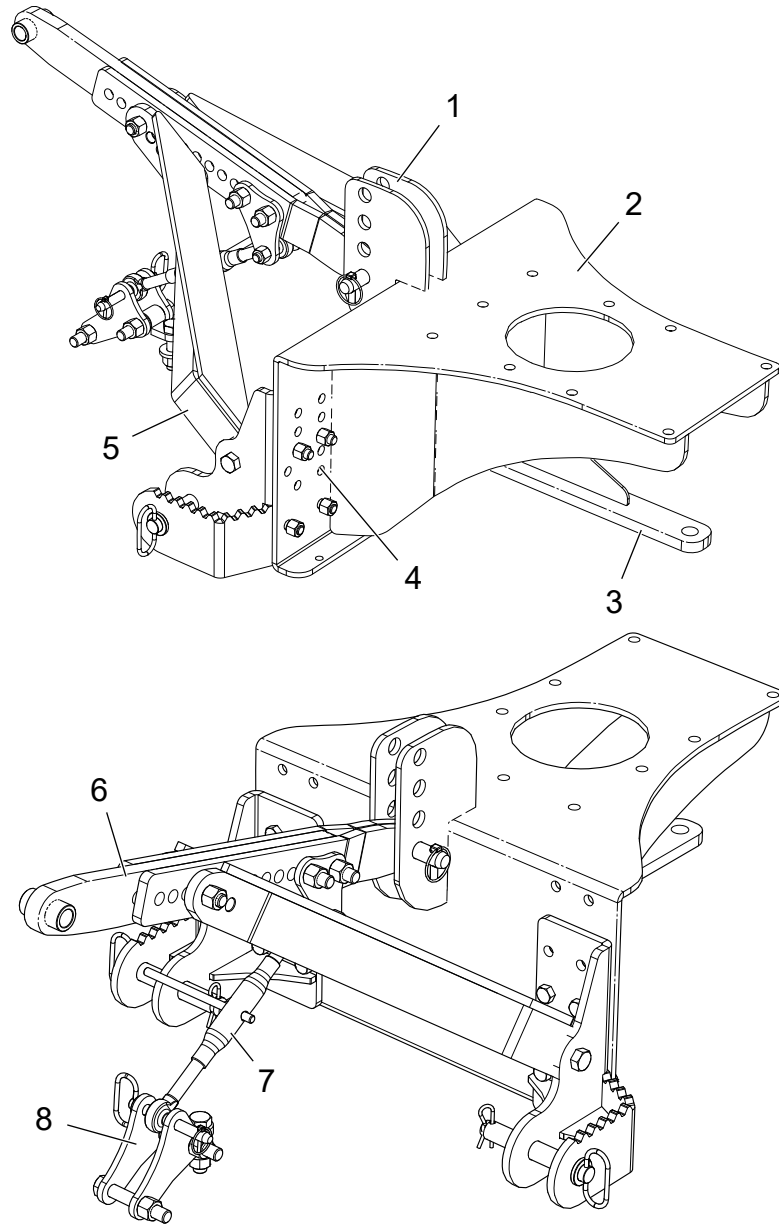

Fig. 8—L400 Log Boom Three-point Hitch Adapter

- |                                |                          |
|--------------------------------|--------------------------|
| 1. Tie Back Bracket            | 5. Lower Hitch Point     |
| 2. Grapple Boom Mounting Plate | 6. Top Link Tie Back Bar |
| 3. Trailer hitch               | 7. Drawbar Turnbuckle    |
| 4. Dual Height Mounting Holes  | 8. Drawbar Bracket       |

## 4. Controls

The grapple hydraulic system can be powered either from the tractor hydraulic circuit or from its own self-contained power pack. The controls function in the same manner, regardless of the power source.

Before starting to work, all operators should familiarize themselves with the location and function of all controls.

### 4.1 Operator Console Swivel

Rotate the operator console so it is opposite the work area. If work area is on the left of the trailer, position the control station on the right of the trailer.

Loosen the lock handle under the console frame. Turn the console to the desired position. Tighten lock handle.

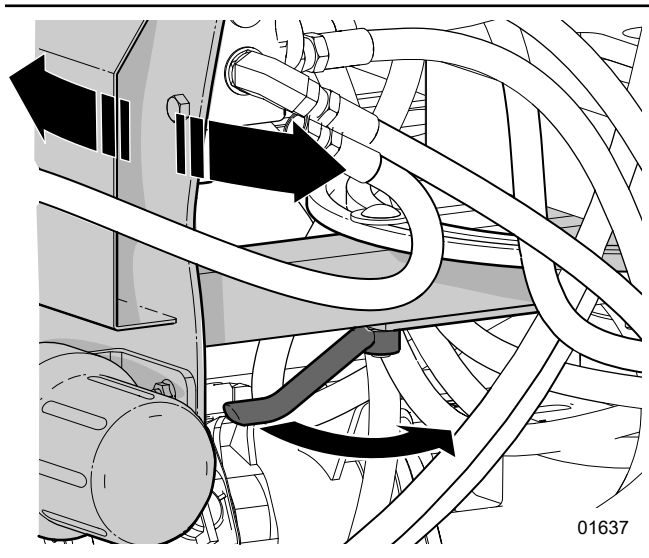

Fig. 9—Operator Console Lock Handle

### 4.2 Main Directional Control Valve

The main control valve has five levers that control the stabilizers, boom movements, and grapple. The two outer levers control the position of the stabilizers, and the other three levers operate the main boom, dipper boom, and grapple.

The control panel can swivel to either side to allow operation from either side of the trailer tongue.

Auxiliary valves for winch, sliding axle (LXT95) and hydraulic articulated tongue (LXT115) are mounted on front of the control panel when equipped.

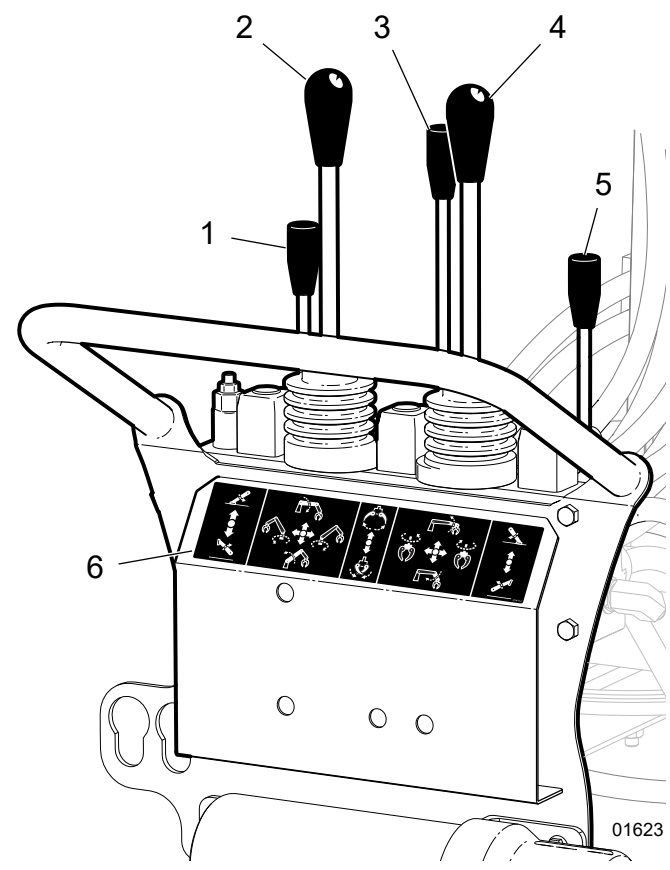
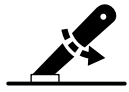

Fig. 10—Operator Console

1. Left-hand Stabilizer Raise/Lower
2. Main Boom Raise/Lower, Rotate
3. Grapple Open/Close
4. Dipper Boom Raise/Lower, Grapple Rotate
5. Right-hand Stabilizer Raise/Lower
6. Control Valve Function Decal



### 1. Left-hand Stabilizer



**Stabilizer lower**—push the lever forward to lower the stabilizer.

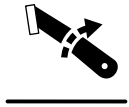

**Stabilizer raise**—pull the lever back to raise the stabilizer.

### 2. Main Boom Raise/Lower, Rotate

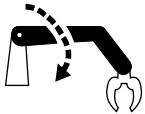

**Main boom lower**—push the lever forward to lower the main boom.

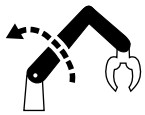

**Main boom raise**—pull the lever back to raise the main boom.

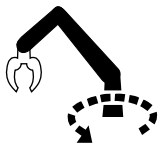

**Main boom rotate left**—push the lever to the left to rotate the main boom counterclockwise.

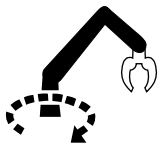

**Main boom rotate right**—push the lever to the right to rotate the main boom clockwise.

### 3. Grapple Open/Close

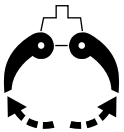

**Grapple open**—push the lever forward to open the grapple forks.



**Grapple close**—pull the lever back to close the grapple forks.

### 4. Dipper Boom Raise/Lower, Grapple Rotate

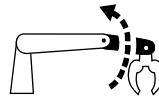

**Dipper boom raise**—push the lever forward to raise the dipper boom.

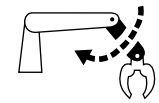

**Dipper boom lower**—pull the lever back to raise the dipper boom.



**Grapple rotate counterclockwise**—push the lever left to rotate the grapple counterclockwise.



**Grapple rotate clockwise**—push the lever to the right to rotate the grapple clockwise.

### 5. Right-hand Stabilizer



**Stabilizer lower**—push the lever forward to lower the stabilizer.



**Stabilizer raise**—pull the lever back to raise the stabilizer.

## 4.3 Hydraulic Power Pack

### 4.3.1 Engine Controls

LXT95 Grapple power packs are equipped with a Honda® GX200 engine. LXT115 models are equipped with a Honda GX270 engine. The LXT95 engine is illustrated, however the controls are essentially the same for both engines.

Refer to the engine manufacturers operator's manual for further detailed instructions before starting.

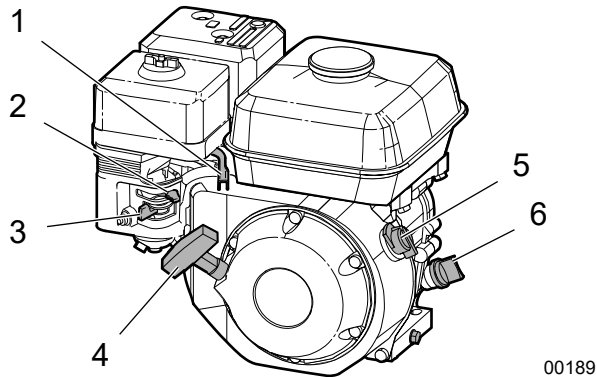

Fig. 11 – Engine Controls

1. Throttle Lever
2. Ignition Switch
3. Oil Level Check
4. Oil drain Plug
5. Starting Rope
6. Fuel Valve Lever
7. Choke Lever

### Ignition Switch

This rotary switch controls the ignition system.

- The engine operates in the ON position. Before starting the engine, turn the switch to ON.
- Turn it counterclockwise to OFF to stop the engine.

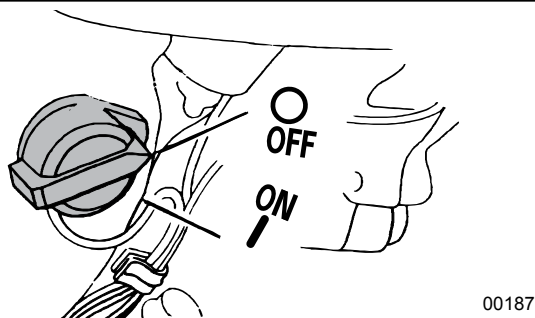

Fig. 12 – Ignition Switch

### Choke Lever

The choke lever opens and closes the choke valve in the carburetor.

- Place the choke lever in the CLOSED position (3) when starting a cold engine.
- Move the choke lever to the OPEN position (2) after the engine starts. When restarting a warm engine, leave the lever in the OPEN position.

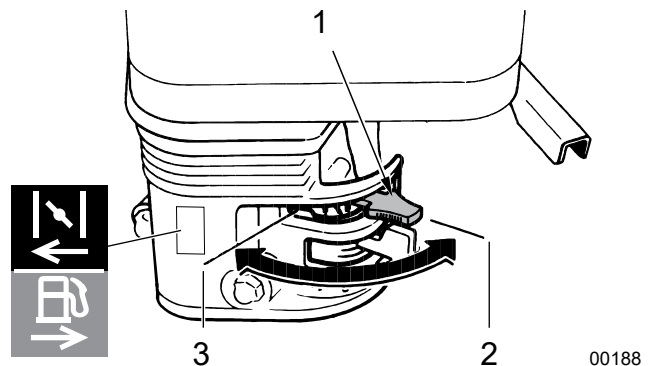

Fig. 13 – Choke Lever

1. Choke Lever
2. Choke Open Position
3. Choke Closed Position

### Fuel Shut-off Valve

The engine is equipped with a valve between the fuel tank and the carburetor.

- Slide the fuel valve lever toward the block (2) to turn fuel ON, and away (3) to turn OFF.
- Turn the fuel OFF when not in use or when transporting.

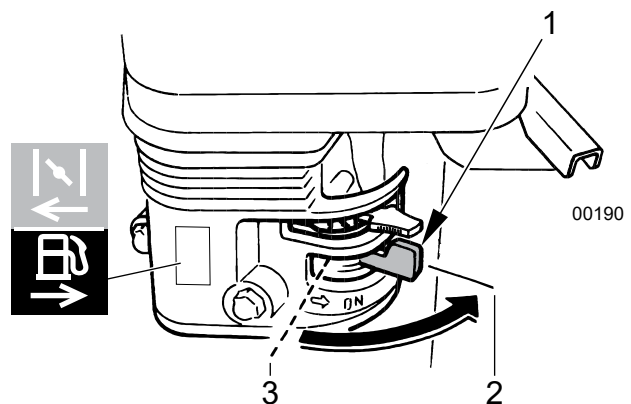
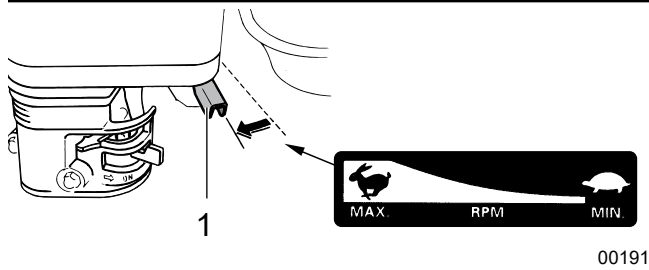

Fig. 14 – Fuel Valve Lever

1. Fuel Shut-off Valve Lever
2. ON Position
3. OFF Position

## Throttle Lever

This lever controls the engine speed. Move the lever side to side to increase or decrease engine rpm. Always operate the engine with the throttle lever in the MAX position.

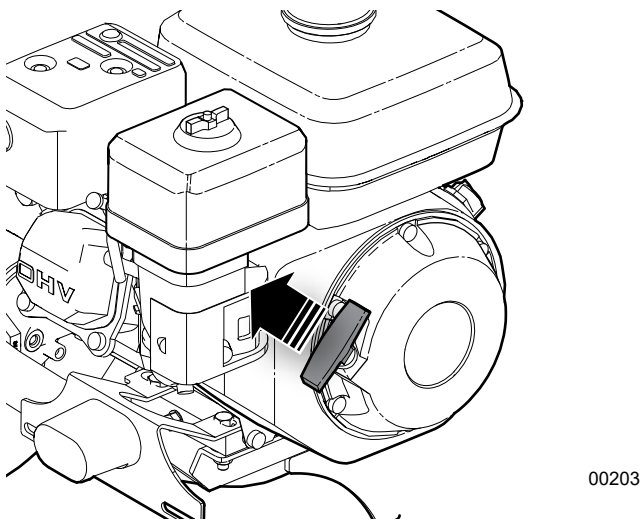

**Fig. 15**– Throttle Lever Positions

1. Throttle Lever

## Recoil Starter

Pull the starter grip out lightly until resistance is felt, then pull briskly in the direction of the arrow as shown below. Return the starter grip gently.



**Fig. 16**–Recoil Starter

## 4.3.2 Hydraulic Reservoir

The hydraulic reservoir has a dipstick with high and low indicators and a spin on filter.

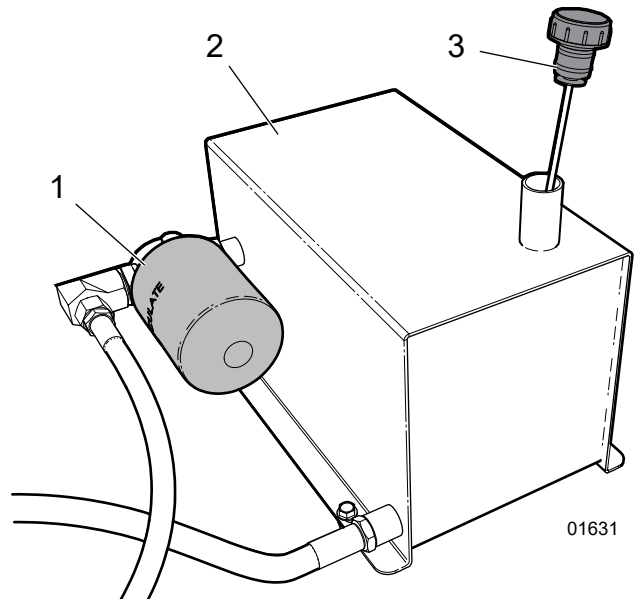

**Fig. 17**–Power Pack Hydraulic Reservoir

1. Return Filter
2. Reservoir
3. Dipstick

**Reservoir capacity 4.6 US gal (17.5 L).**

## 4.4 Bunk Posts

The bunk posts are designed to hold and secure heavy loads, however are easily removed if required. To remove, lift straight up and out.

The beveled post stop and post mount ensures that if bumped or knocked with a grapple load the bunk posts can swing away and return to position on their own.

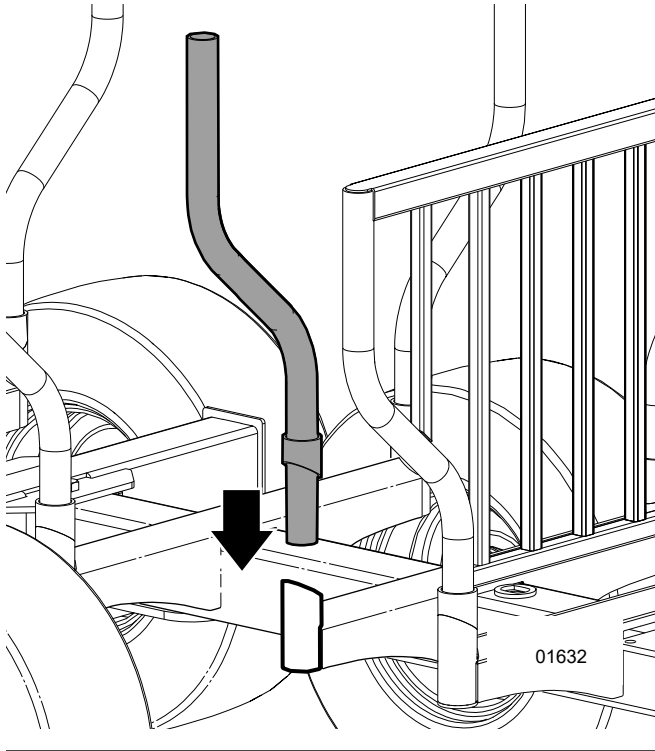

Fig. 18 – Bunk Posts

## 4.5 Hydraulic Sliding Tandem Axle

### (LXT95 only)

The sliding tandem axle adjusts tongue weight and can be used to help balance a load or adjust the tongue weight for added traction if required.

Check that the trailer is parked on level ground and the frame is not under tension or twisted.

**IMPORTANT!** Tandem axle should be adjusted with trailer unloaded. Tandem bolt is not accessible when loaded.



Reinserting the tandem bolt is made easier with the help of an assistant.

1. Connect trailer to the tow vehicle.
2. Remove the tandem nut and bolt as shown.
3. Start up the hydraulic power pack or apply hydraulic power to the control valve from the tractor.

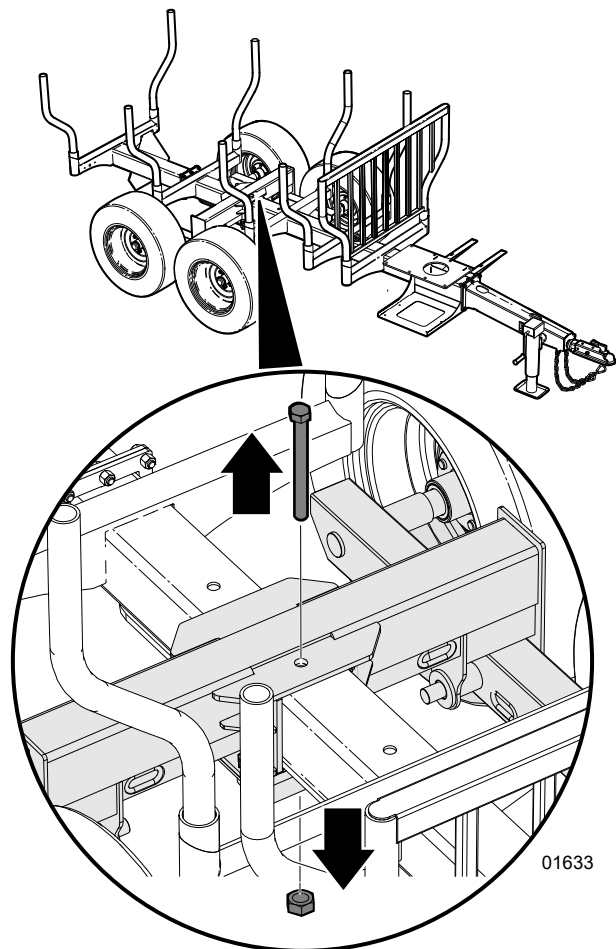

Fig. 19 – Tandem Axle Bolt

## Increasing trailer tongue weight

1. At the auxiliary control valve, push the left-hand lever forward to move the tandem axle back on the frame.
2. Adjust axle position, then insert the tandem bolt and locknut.

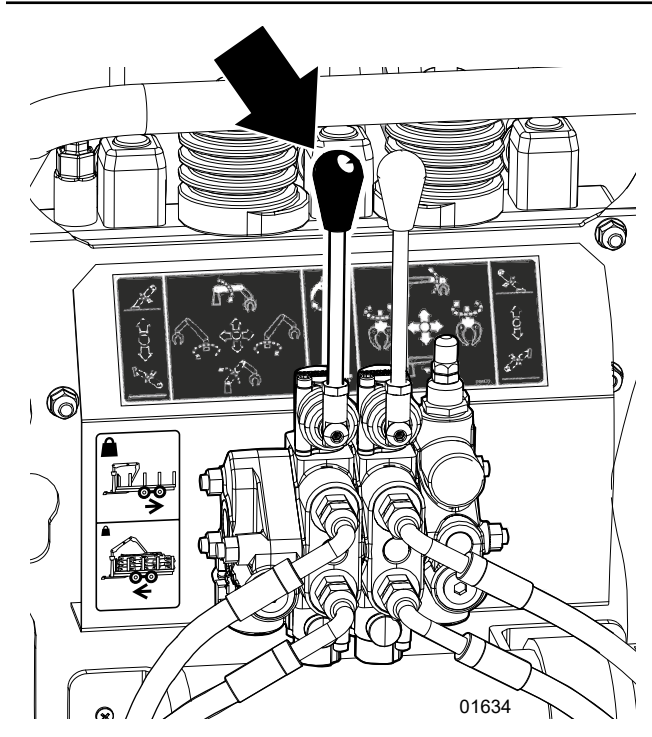

Fig. 20 – Auxiliary Control Valve

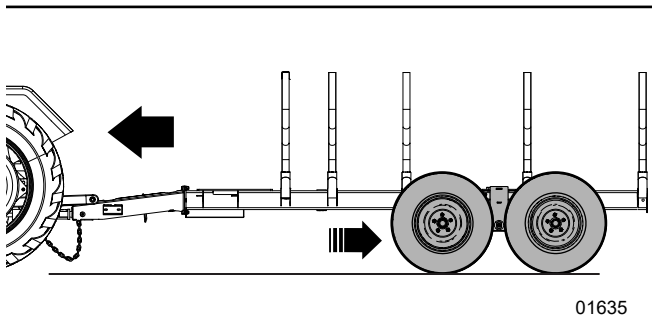

Fig. 21 – Sliding Axle Back

## Decreasing trailer tongue weight

1. Pull the valve lever back towards you to move the axle forward on the frame.

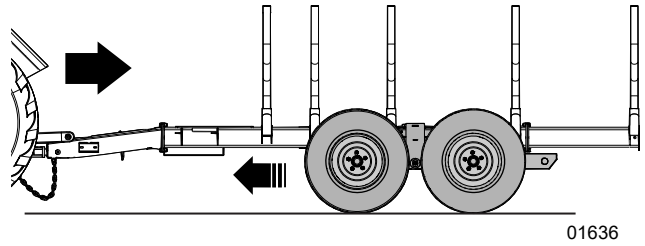

Fig. 22 – Sliding Axle Forward

2. Adjust axle position, then insert the tandem bolt and locknut.

## 4.6 Articulated Trailer Tongue

### (LXT115 option)

The Articulating Tongue Kit provides an extra pivot point in the trailer tongue that allows the tractor and trailer to turn tighter, for example on tight bush trails. The pivot is controlled by a hydraulic cylinder making the pivot rigid when reversing for example. The cylinder is controlled by the tractor remote valve lever. The trailer tongue is kept further away from the tow vehicle by adding this extra hinge point.

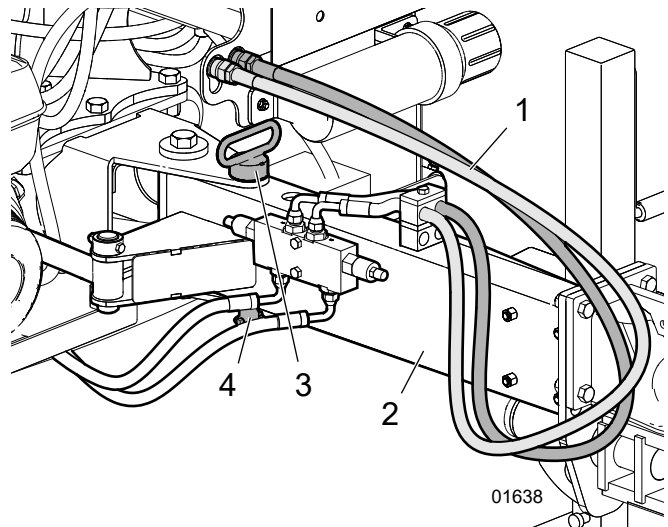

Fig. 23 – Articulating Trailer Tongue

1. Pressure and return hydraulic hoses
2. Articulating trailer tongue
3. Hitch pin
4. Lynch pin

- Connect the hydraulic hoses for the Articulated Tongue to tractor supply and return remote connections.
- Pull the hitch pin, then use the tractor's remote hydraulic control to rotate the trailer tongue.

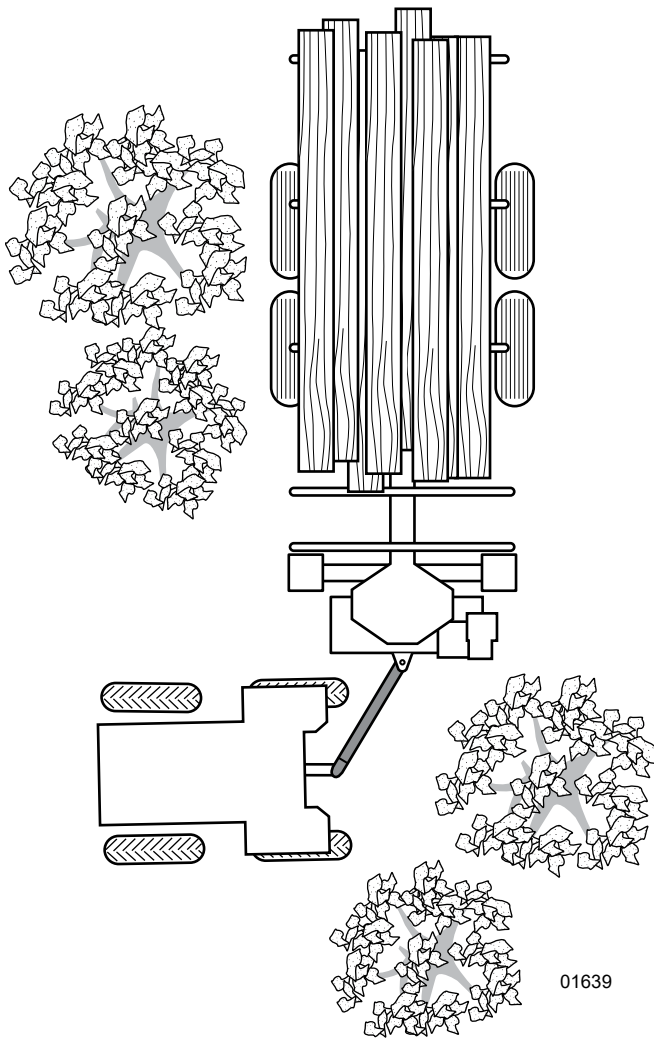

Fig. 24—Maneuvering with Articulated Trailer Tongue

## 4.7 Hydraulic Winch

### (Option)

The two-speed winch is used to pull material in closer for the grapple to pick. An auxiliary control valve is mounted on the front of the operator console. The winch drive is mounted on the top side of the boom. The winch specifications are different for each grapple model, but the operation is the same.

### Control Valve

- Pull the control lever back and hold to start the winch and wind the rope in. Releasing the lever returns it to neutral and the winch stops.
- Push the lever forward to allow the rope to unwind under power.

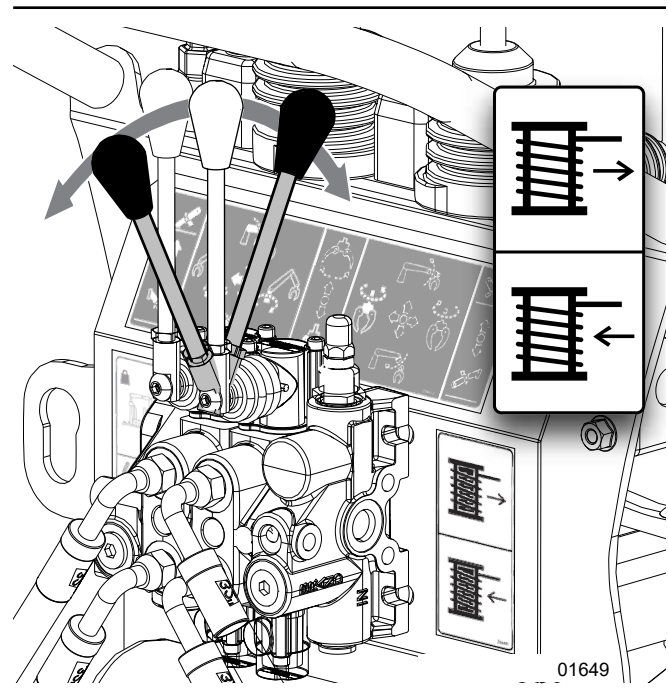

Fig. 25—Winch Control Valve

## Two-speed Winch Drive

The winch drive has a three-position lever to control the gear speed. The decal indicates winch drive positions.

Controls are described when standing on the side of the machine facing the winch drive.



**Fast Position.** Push the lever forward towards the boom to engage high speed.



**Freewheel Position.** Place the lever in the center position to pull the winch rope out.

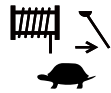

**Slow Position.** Pull the gear lever outward to engage low speed.

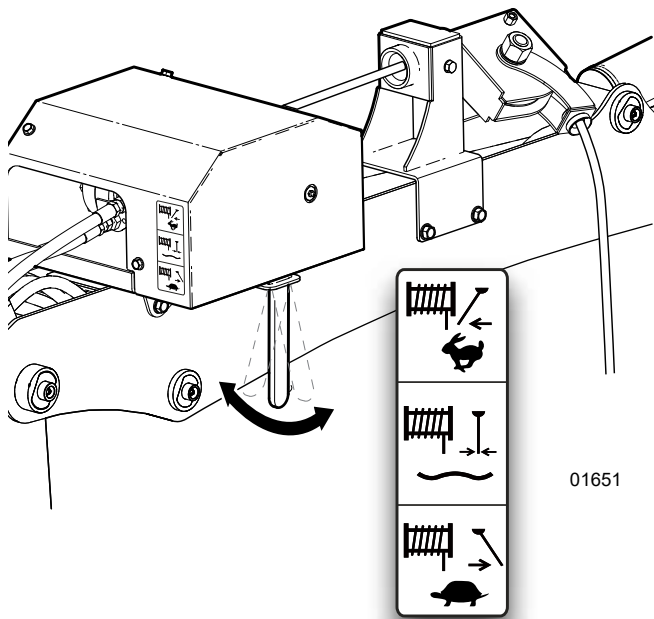

Fig. 26—Winch Gear Lever

## 4.8 Braking Systems

Trailer brakes help to control the trailer and its load. The LXT95 Log Loader / Trailer is not intended for use or transport on public roadways. Surge brakes on the trailer help to slow the trailer when descending hills or slowing. The LXT115 Log Loader / Trailer is equipped to travel on public roadways with electric brakes, turn signal and brake lights. Always consult your local transportation authority for requirements to travel on public roadways.

**IMPORTANT NOTICE!** Laws regarding towing and trailers vary across regions. Make sure you are in full compliance with the law in your area regarding trailer brakes, coupler requirements, safety chains, trailer width requirements, trailer lights, and so on.

Contact your government motor vehicle department for more information. In addition, check with your vehicle dealer or vehicle owner's manual to make sure you have the proper towing vehicle and hitch attachments for the load being pulled.

### 4.8.1 LXT95 Surge Brakes

LXT95 trailer Surge Brakes operate independently of the tow vehicle. No electrical connection is required. When the tow vehicle slows down, the trailer tries to continue at the same speed. This compresses the tongue so the brake plunger presses on the master cylinder to actuate the brakes.

The brakes have a freewheel function which releases them when reversing. A primary shoe on a pivot provides normal braking in the forward direction but allows the primary shoe to rotate away from the drum surface when reversing.

- When approaching a long downhill grade, DO NOT shift into lower gears. This can cause the surge brakes to be applied for the entire descent. DO NOT ride the brake pedal going downhill. When you need to slow down on steep inclines, press the brake pedal to slow down then let off the brake pedal slightly to let the brakes cool before you press the brake pedal again.
- DO NOT use weight-distributing hitches with surge-braked trailers. Overloading or improper installation of weight-distributing hitches may not let hydraulic surge brake actuators work and the tow vehicle and trailer may take longer to stop.
- Before use, your trailer brakes should be burnished-in by applying the brakes 20–30 times. Allow ample time for brakes to cool between application. This allows the brake shoes to seat into the drum surfaces.

The LXT95 surge brake system has a lockout on the trailer tongue. Flip the brake plunger lock over to contain the plunger and keep the mechanism from operating.

The lockout can be used when traveling off road or over rough terrain to prevent the brakes from engaging during bumping and jarring. Flip the lockout latch outward to re-engage the system.

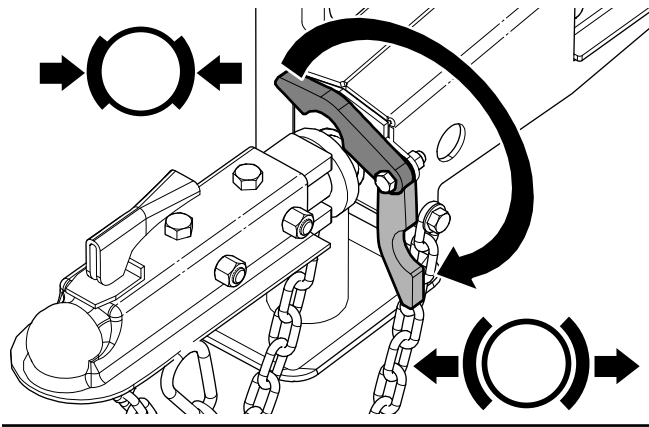

Fig. 27 – Surge Brake Plunger Lock

## 4.8.2 LXT115 Electric Brakes

LXT115 electric brakes are dependent on an electrical signal from the tow vehicle. A brake controller on the tow vehicle is required so the amount of braking on the trailer can be controlled and applied as the situation requires.

The brake controller receives a signal when the tow vehicle is slowing down and applies the trailer brakes. The braking system also works when reversing the trailer.

DO NOT use your tow vehicle or trailer brakes alone to stop both vehicle and load. Your brake controller must be set up according to the manufacturer's recommendations to ensure proper synchronization between the tow vehicle and the trailer. Additionally, you may have to make small adjustments occasionally to accommodate changing loads and driving conditions.

Proper synchronization of tow vehicle to trailer braking can only be accomplished by road testing. Brake lockup and sensitivity is quite often due to the lack of synchronization between the tow vehicle and the trailer being towed, (too high of a threshold voltage (over 2 volts), or under adjusted brakes).

Before any synchronization adjustments are made, your trailer brakes should be burnished-in by applying the brakes 20–30 times with approximately a 20 mph (32 km/h) decrease in speed, for example 40–20 mph (65–33 km/h.) Allow ample time for brakes to cool between application. This allows the brake shoes and magnets to slightly wear-in to the drum surfaces.



## 5. Machine Setup

Use the tow vehicle to position the grapple and trailer at the work site.

### CAUTION!

Park the machine so prevailing winds blow exhaust gases / fumes away from the operator.

W006

### WARNING!

Do operate the machine when not attached to a tow vehicle. Machine could tip over causing serious injury or death. Keep tow vehicle attached with stabilizers lowered, firmly on the ground for stability.

W097

- Check for leaks or damage to the engine, all hoses and hydraulic components. Repair as required.
- The machine is designed to be used while attached to the tow vehicle. The log trailer requires the stability of the tow vehicle while lifting or winching heavy loads. Do not operate if not attached to the tow vehicle. Lower the trailer jack for extra stability.
- Start the engine on the power pack or connect the grapple hydraulic hoses to the tractor remote connections. Set the tractor hydraulic control in detent.

1. Set tow vehicle park brake.
2. Position control panel so the operator is opposite the landing zone (facing the work area).
3. Lower stabilizer legs so that they are firmly placed on the ground.
4. Remove boom lock pin.

Check all functions of the hydraulic system before beginning work.

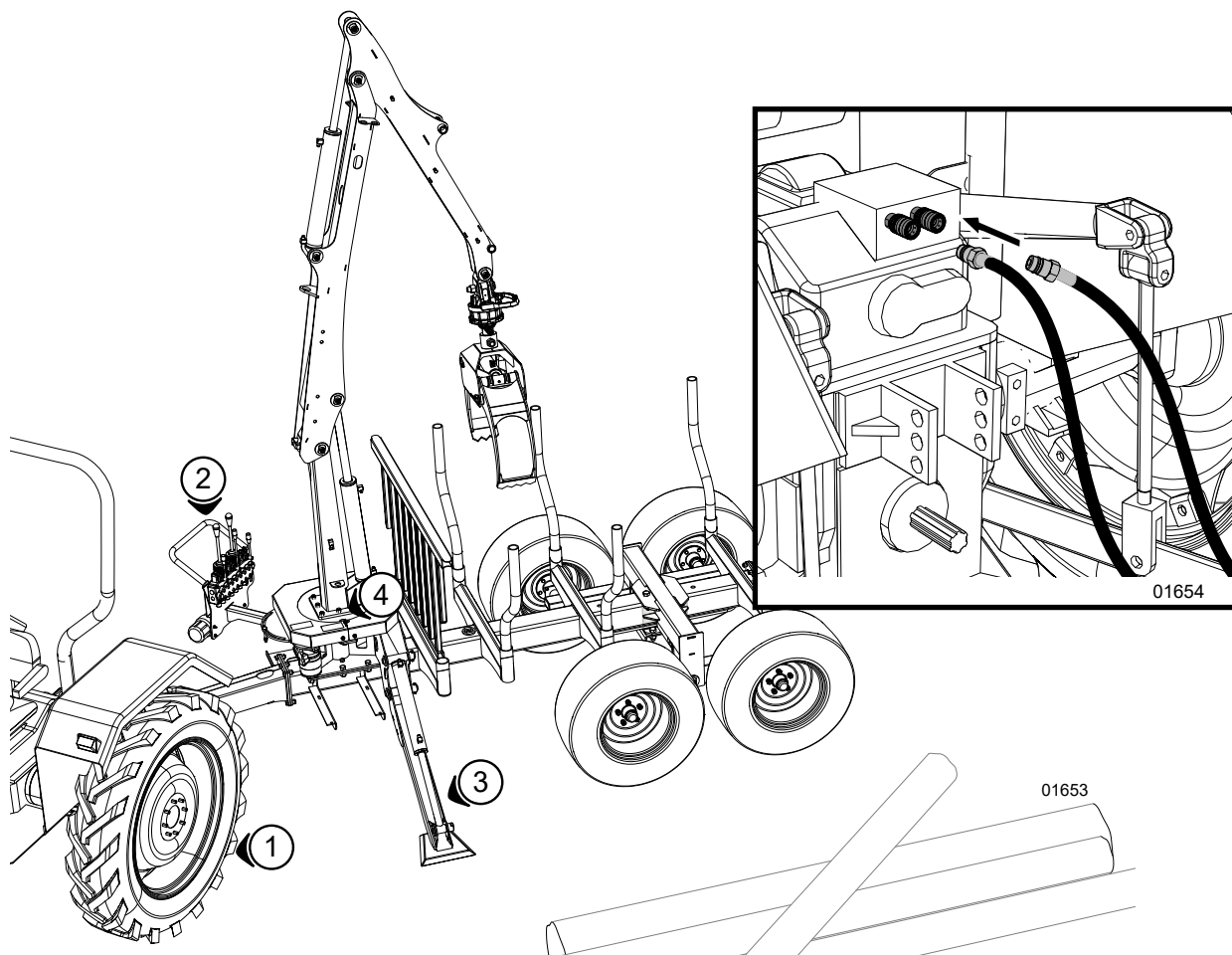

Fig. 28—Machine Setup

## 6. Operating Instructions

The operator is responsible to be familiar with and follow all operating and safety procedures.

### 6.1 Jobsite Safety

- Please remember it is important that you read the operator's manual and heed the safety signs on the machine. They are there for your safety, as well as the safety of others. The safe use of this machine is strictly up to you, the operator.
- Before moving, making, adjustments or servicing, put the machine in safe condition:
  - Grapple is closed and resting on trailer
  - Boom lock pin installed
  - Fuel valve is turned off (power pack equipped)
  - Trailer load is secure
  - Tow vehicle parking brake is applied. Engine stopped
- Extend stabilizers to support frame during loading and unloading.
- Position the trailer to provide a firm base for the stabilizer pads before loading or unloading.
- Stay 20 feet (6 m) away from power lines. Electrocutation can occur without direct contact. Stay away from overhead utilities and obstructions.
- Keep all bystanders out of the work zone, at least 20 ft (6 m) feet away from trailer, grapple and logs when loading or unloading or when engine is running.
- Position the controls and operate the machine opposite the work zone.
- Be aware of your operator safe zone and keep boom and material out of it.
- Do not operate machine inside a closed building to prevent asphyxiation from engine exhaust.
- Never consume alcoholic beverages or drugs while operating this equipment. Alertness or coordination can be affected. Consult your doctor about operating this machine while taking prescription medications.
- Do not allow riders on this machine at any time. There is no safe place for any riders. Do not move or carry people on boom or grapple.
- Never allow children or unauthorized people to operate or be around this machine.
- When operating this equipment, it is recommended to have at least two operators present and trained in safe operation of the machine. All operators must be completely familiar with all components of the machine and their function.
- Keep hydraulic lines and fittings tight, in good condition and free of leaks.

- Keep the working area clean and free of debris to prevent tripping. Operate only on level ground.
- Do not overload boom lift or trailer capacity.
- Review safety instructions annually.

### 6.2 Before Start-up

- Clear the area of bystanders.
- Review the machine controls. See page 24.
- Review and follow the Pre-start Checks (see next page).
- Survey the work site. Position machine in a clear, level work area at the work site. Do not start boom and grapple operation until in position.
- Set up the machine as shown on page 33. Stabilizers must be fully lowered, and trailer attached to tow vehicle.

### Protective Equipment

Anyone operating this equipment or working nearby must wear appropriate PPE. This list includes but is not limited to:

- Safety shoes with slip resistant soles.
- Safety glasses or face shield.
- Hearing protection.
- Heavy or leather gloves.

### Training

Each operator must be trained and familiar with the set up and operation of the machine and its components.

New operators, or experienced operators at the start of a new season should practice moving the boom, dipper and grapple. Move the trailer to an open area without obstructions or bystanders to set up the machine. Practice moving and manipulating each component to be familiar and comfortable with how they function.

Time invested in training and practice makes a more efficient operation and a safer working environment.

### 6.3 Machine Break-In

Although there are no operational restrictions on the machine when used for the first time, it is recommended that the following mechanical items be checked:

#### After 1–5 hours of operation:

1. Check all nuts, bolts and other fasteners. Tighten to their specified torque.
2. Check hydraulic system for leaks. Tighten all leaking fittings and replace any leaking components.
3. Check machine fluid levels: Fuel, engine oil, and hydraulic oil reservoir. Top up as required.
4. Check condition of winch, if equipped. Check the condition of the rope. Replace if cut, knotted, worn or if it has any broken strands.
5. Check for entangled material. Remove all entangled material before resuming work.
6. Lubricate all grease fittings.

#### After 20 hours of operation:

7. Repeat steps 1 through 6 listed above.
8. Change engine oil after 20 hours. See engine manual.
9. Go to the normal servicing and maintenance schedule as defined in the Maintenance Section. See page 45.

### 6.4 Pre-start Checks

Items to Check	<input checked="" type="checkbox"/>
<b>Boom and Grapple</b>	
Machine is lubricated as indicated in the Maintenance Schedule on page 50.	<input type="checkbox"/>
All boom pivot points, grapple and stabilizers move freely.	<input type="checkbox"/>
Check for leaks in the hydraulic system. Tighten leaking fittings. Repair or replace any damaged components.	<input type="checkbox"/>
Make sure all guards and shields are in place.	<input type="checkbox"/>
Check all fasteners and hardware. Re-torque if required.	<input type="checkbox"/>
<b>Power Pack</b>	
Follow the pre-operation check in your engine owner's manual.	<input type="checkbox"/>
Check hydraulic reservoir. Top up as required.	<input type="checkbox"/>
Check for entangled material. Remove all entangled material before resuming work.	<input type="checkbox"/>
Check for leaks in the hydraulic system. Tighten leaking fittings. Repair or replace any damaged components.	<input type="checkbox"/>
<b>Log Trailer</b>	
Check tire pressure. Inflate as required.	<input type="checkbox"/>
Check wheel lug nut torque. See torque table on page 60.	<input type="checkbox"/>
Check mounting legs are securely pinned (dumper or flatbed only).	<input type="checkbox"/>
Check adjustable tandem is pinned (LXT95 only).	<input type="checkbox"/>
<b>Three-point Hitch Mount (Option)</b>	
Check all fasteners and hardware on the 3-point hitch and adaptor. Re-torque if required.	<input type="checkbox"/>

## 6.5 Engine Oil Level Check

Check engine oil level daily.

Check with the machine parked on level ground and the engine stopped.

**IMPORTANT! Running the engine with a low oil level can cause engine damage that is not covered by warranty.**

1. Remove the oil level dipstick and wipe it clean.
2. Fully insert the oil level dipstick, then remove it to check the oil level. **The proper level is when the oil is visible at the full (upper) mark on the dipstick.**
3. If the oil level is low, add oil until the level is at the full mark. **SAE 10W-30 is recommended for general use.**
4. Reinstall the oil level dipstick.

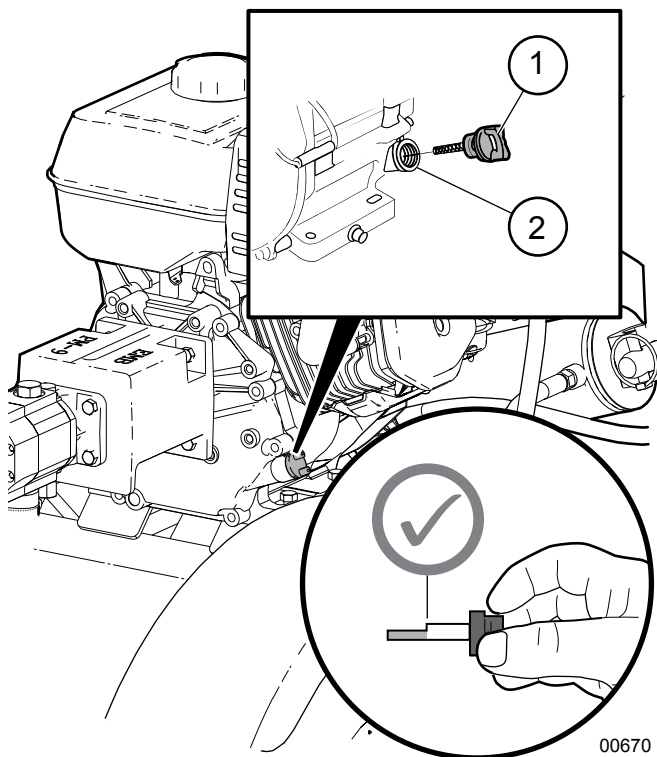

Fig. 29—Engine Oil Level check

1. Oil Level Dipstick
2. Oil Filler

Refer to the engine owner's manual included in the manual tube for further information on engine oils.

## 6.6 Fuel Level Check

Check the fuel level daily.

Starting with a full tank helps to eliminate or reduce operating interruptions for refueling.

The fuel tank is located on the engine. Avoid running the tank dry.

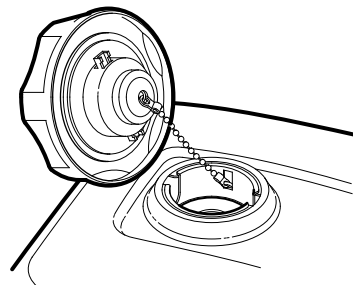

00198

Fig. 30—Fuel Filler Cap

### 6.6.1 Refueling

Fuel tank capacity: 1.59 US gal (6 L).

**WARNING!**



Fuel vapors can explode causing injury or death. Do not smoke while refueling. Keep sparks, flames, and hot components away.

W027

Refuel in a well-ventilated area with the engine stopped. If the engine has been running, allow it to cool first. Never refuel the engine inside a building where gasoline fumes can come in contact with flames or sparks.

For fuel specification, see *Fluids and Lubricants on page 45*. Refer to the engine manual for additional information on fuels.

1. Clean the area around fuel tank cap. Fill the tank to 1/2" (12 mm) below bottom of filler neck to provide space for any fuel expansion. Do not overfill.
2. Install fuel fill cap securely and wipe up any spilled fuel.

## 6.7 Starting the Engine

### **CAUTION!**

Before starting the engine, review the safety, operating, and maintenance instructions in the engine manual.

W019

### **CAUTION!**



Hearing loss hazard. Prolonged exposure to loud noise may cause permanent hearing loss. Use suitable protection while operating the machine.

W016

Make sure the log grapple is set up to work and otherwise ready to run.

1. If the engine is cold, close the choke (push choke lever to the left). To start a warm engine, leave the choke open (lever pushed to the right).

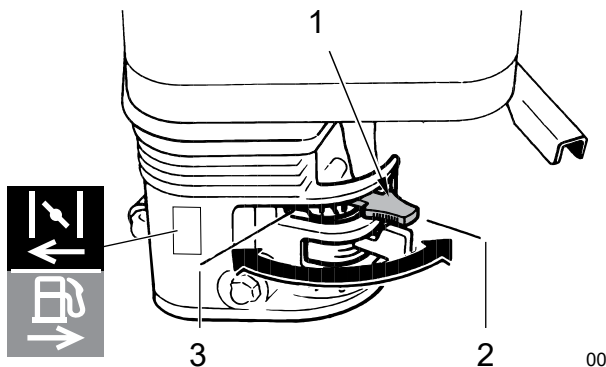
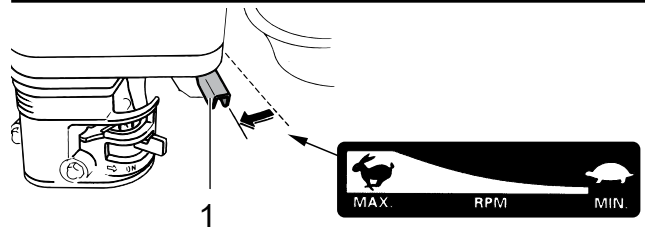

Fig. 31 – Choke Lever

1. Choke Lever
2. Choke OPEN
3. Choke CLOSED

2. Move the throttle lever away from the MIN. position, about 1/3 of the way toward the MAX position.



00191

Fig. 32 – Engine Throttle

1. Throttle Lever

3. Turn the engine ignition switch ON.

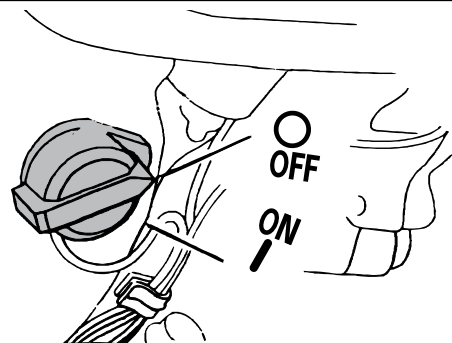

00187

Fig. 33 – Ignition Switch

4. Pull the starter grip out lightly until resistance is felt, then pull briskly in the direction of the arrow as shown below. Return the starter grip gently.

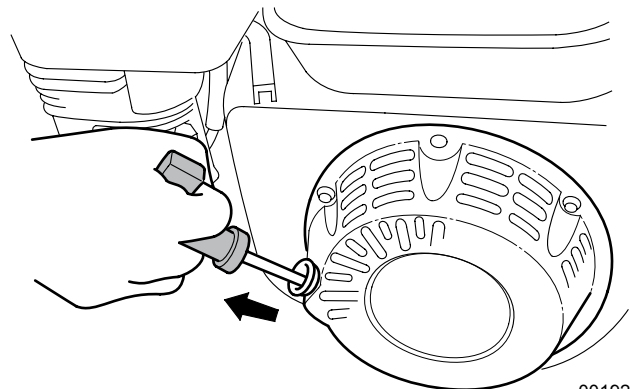

00192

Fig. 34 – Recoil Starter

**IMPORTANT!** Do not allow the starter grip to snap back against the engine. Return it gently to prevent damage to the starter.

5. Leave the engine operating at low throttle for a few minutes to allow it to warm up. Gradually push the choke control lever open (to the left) as the engine warms.

**IMPORTANT! Engine should be warmed up before starting work.**

6. Once the engine is warmed, increase the throttle setting to MAX before beginning.

## 6.8 Stopping

- Move grapple to safe location,
- Secure the trailer from movement.
- Close the grapple and set it on the ground, or clamp the grapple to trailer frame or log.
- If possible, install boom pin lock
- Shut off the engine
- Turn fuel valve off
- Make sure load is secure
- Decrease engine speed to MIN.
- Turn the ignition switch OFF

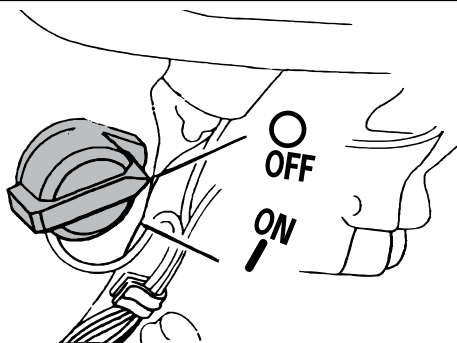

00187

Fig. 35—Ignition Switch

### 6.8.1 Stopping in an Emergency

To stop the engine in an emergency, turn the ignition switch OFF. If possible, carefully lower the grapple load onto the trailer or ground.

Correct fault situation before restarting.

## 6.9 Load Distribution

Always balance the load in the center of the trailer to maintain a balanced weight distribution on the tires and trailer frame—larger logs on the bottom and smaller on top. The best results are obtained when loads are planned in a safe and common-sense manner.

- Do not load logs above the height of the trailer bunk posts.
- Keep logs evenly distributed across the bunk. Do not load logs to create a peak in the center of the load. The load must be as level as possible.
- Make sure logs or branches are not protruding out of the side of the trailer. Load should be contained within the bunk posts.
- Make sure no logs are sitting in an unstable position.
- Secure the load by strapping it down when preparing to transport.

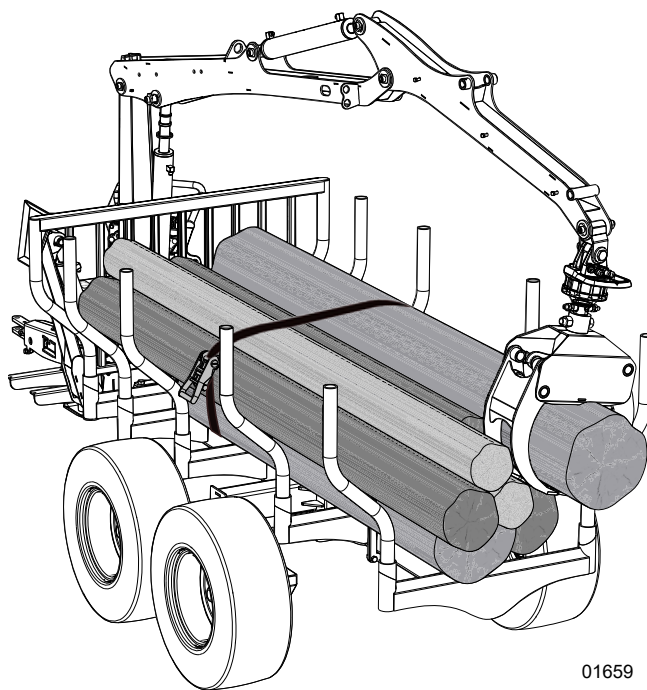

01659

Fig. 36—Strapped-down balanced load below bunk posts

## 6.10 Loading

### **WARNING!**

**Electrocution Hazard. Be aware of overhead or underground power lines. Stay at least 20 ft (6 m) or more away. Serious injury or death could occur from electrocution. Electrocution is possible without direct contact (arcing).**

W015

1. Raise and rotate the boom out over the log to be picked, so that the grapple is positioned at the center of the log.
2. Rotate the grapple until it is at right angles to the length of the log.
3. Open the grapple and lower it over log.

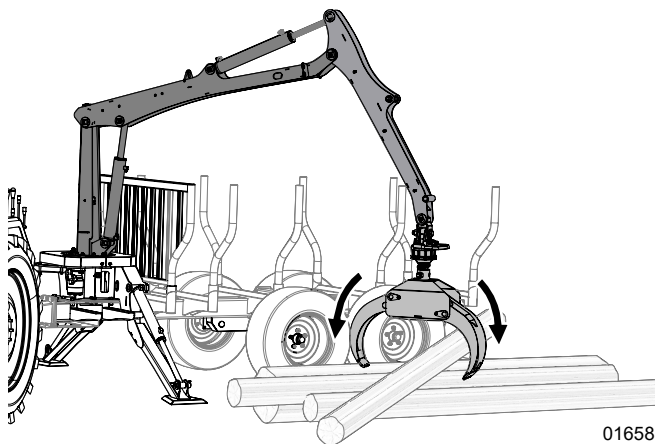

Fig. 37 – Open grapple and lower over log

**IMPORTANT!** For safe and efficient operation, estimate the position of the log center of gravity to keep it balanced when rotating, lifting, and swinging.

4. Close grapple and lift the log. If the log is not reasonably balanced, then lower the log and reposition the grapple for a more balanced hold.
5. Slowly lift the log high enough to clear the bunk posts.

**IMPORTANT!** When lifting, rotating, and swinging your load, be sure to clear the trailer and boom components.

### **WARNING!**

**Risk of severe injury or death from swinging load or logs falling from overhead load. Do not allow anyone inside the Work Zone while operating the machine. Never lift or move load over personnel.**

W098

6. Carefully rotate the boom and swing the log over the trailer.
7. Using the grapple rotator, align the log over the trailer. Be aware of the end of the log so that it clears the main boom and lift cylinder as you rotate the log.

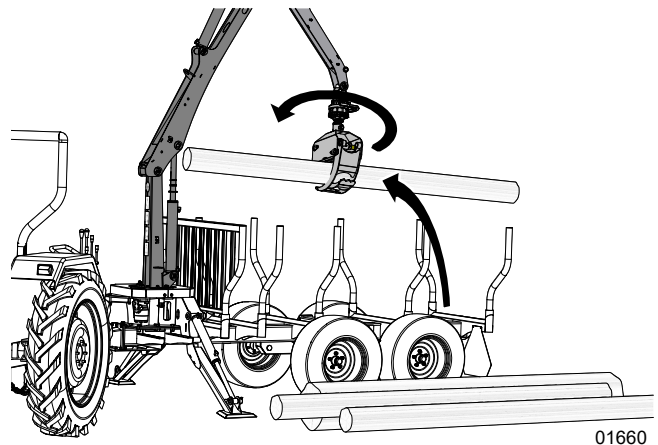

Fig. 38 – Lift and rotate

8. Carefully lower the log on to the trailer and release log.
9. Repeat picking with the next logs until loaded.

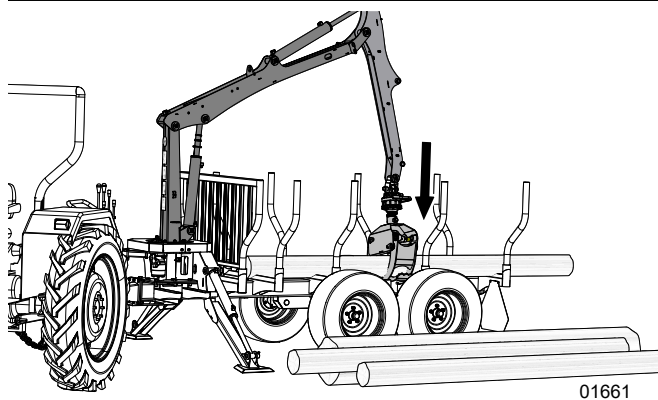

Fig. 39—Lower and release the load

10. Do not load trailer over rated load capacity.
11. Clamp the grapple to one of the logs on the trailer to keep the boom in a safe position when preparing to transport.

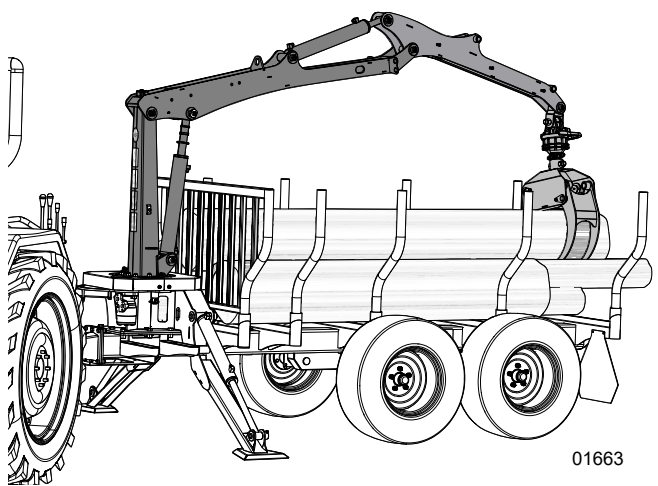

Fig. 40—Grapple safe position

## 6.11 Unloading and Stacking Logs

- Position the trailer to provide a firm base for the stabilizer pads before loading or unloading. Extend stabilizers to support frame.
- Determine a safe log stack location. Log stack should be on level ground.
- Ensure stack location does not interfere with safe loading / unloading of material.
- Tall log stacks should be braced to prevent collapse.

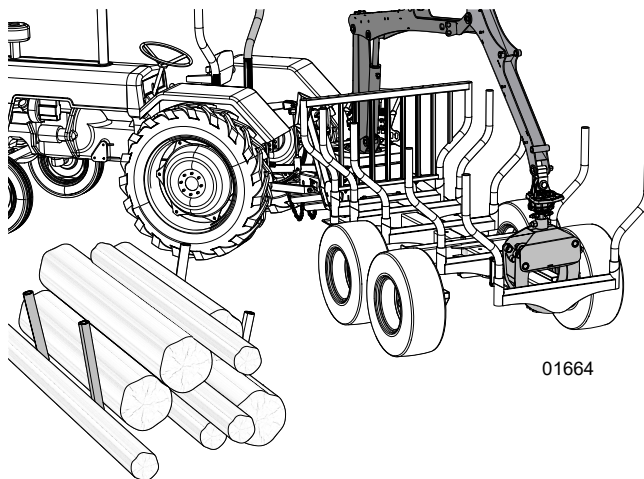

Fig. 41—Braced Stack

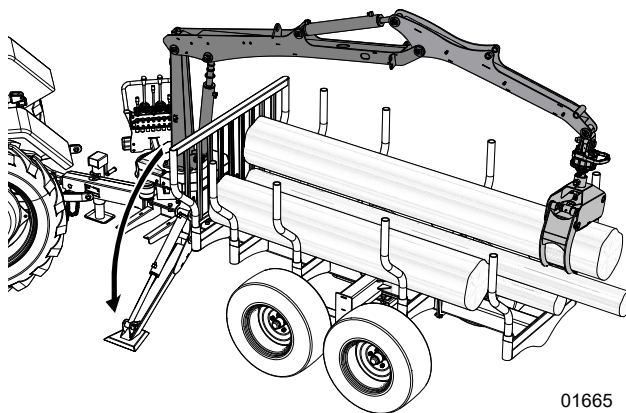

Fig. 42—Stabilizers extended

1. Release the boom from safe position. Raise the boom over the log to be picked so that the grapple is positioned at the center of the log.

**IMPORTANT! Place grapple at the log center of gravity to keep it balanced when rotating, lifting, and swinging.**

2. Rotate the grapple as required until it is at right angles to the length of the log.



3. Open the grapple and lower it over log.
4. Close grapple and pick up the log. If the log is not reasonably balanced, lower and reposition.

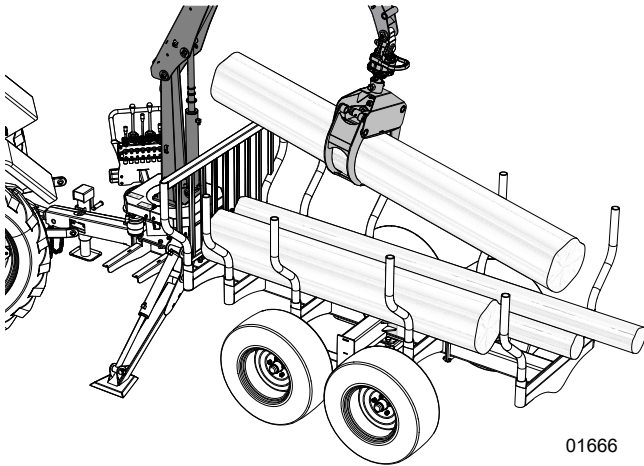

01666

Fig. 43—Picking up Logs

**IMPORTANT!** Be careful to clear trailer and boom when lifting, rotating, and swinging your load.

5. Slowly lift the log high enough to clear the bunk posts. Be aware of the end of the log so that it clears the main boom and lift cylinder as you lift and swing the log.
6. Carefully rotate the boom and swing the log over the ground.
7. Using the grapple rotator, align the log over landing zone.

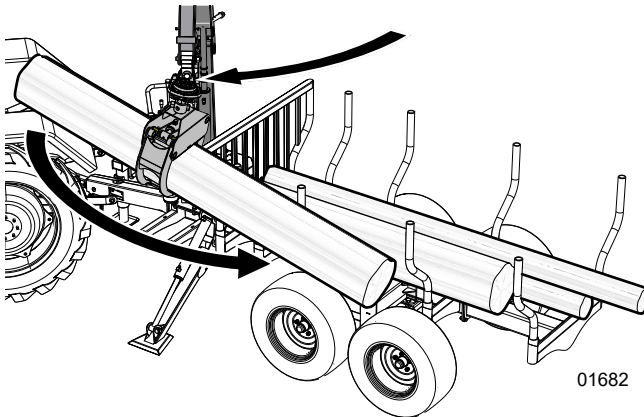

01682

Fig. 44—Swing and rotate

8. Carefully lower the log to the ground and release.

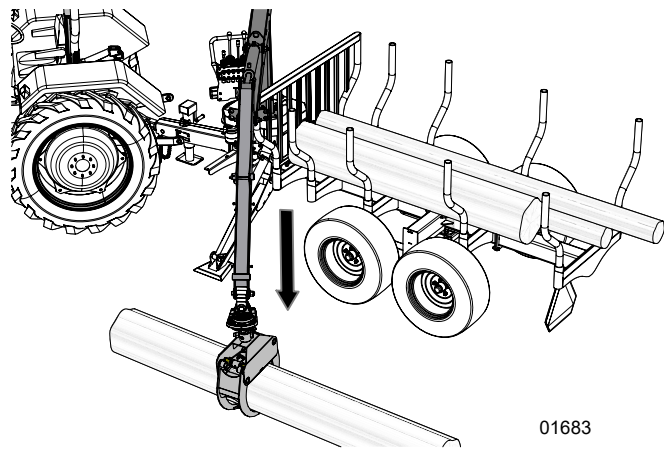

01683

Fig. 45—Lower and release

9. Prepare for transport.

- Clamp the grapple to the frame of the trailer to keep the boom in a safe position
- Raise the stabilizers
- Crank or swing up the trailer jack

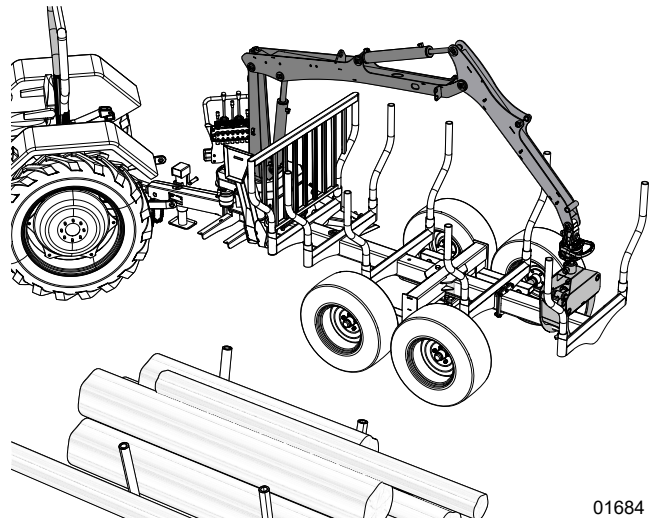

01684

Fig. 46—Grapple safe position

## 6.12 Operating Hints

### General

- Delimb all logs to make it easier and safer for loading, transporting and unloading.
- Be sure the trailer is always securely attached to the tow vehicle. This provides required stability when loading / unloading heavy logs.
- Stay away from overhead power lines to prevent serious injury or death from electrocution. Electrocution can occur without direct contact.
- Always fully extend the stabilizers to provide stability to the machine during operation. Be sure the area under the stabilizers can provide the required support.
- Position the grapple / trailer as close to the landing zone as possible. This will make maneuvering the grapple easier especially with heavy logs.

### Rugged Terrain

The machine can be used in a variety of conditions including rugged terrain. The area must be clear, and the ground be firm and level.

In cases where that is not possible:

- Make sure that the stabilizer feet have firm footing (use planks or stabilizer pads).
- Use the stabilizers to keep the boom and trailer as level as possible.
- Apply parking brakes of the tow vehicle for extra stability.
- Place chocks in front of and behind the tow vehicle and the trailer tires to limit the chance of movement.
- Be extra cautious and use common sense.

### Working on Slopes

Park at the top of the slope and winch logs to your position. Make sure that the area is clear, and the ground is firm and level.

Exercise caution when winching. The trailer should always be positioned uphill from the log. Winching downhill is hazardous and may result in the log rolling and striking the operator.

In cases where that is not possible, and working on the slope is required:

- Always position the trailer going up and down the slope rather than across to eliminate the chance to tip the unit over.
- Make sure that the stabilizer feet have firm footing (use planks or stabilizer pads).
- Apply parking brakes of the tow vehicle for extra stability.
- Place chocks in front of and behind the tow vehicle and the trailer tires to limit the chance of movement.

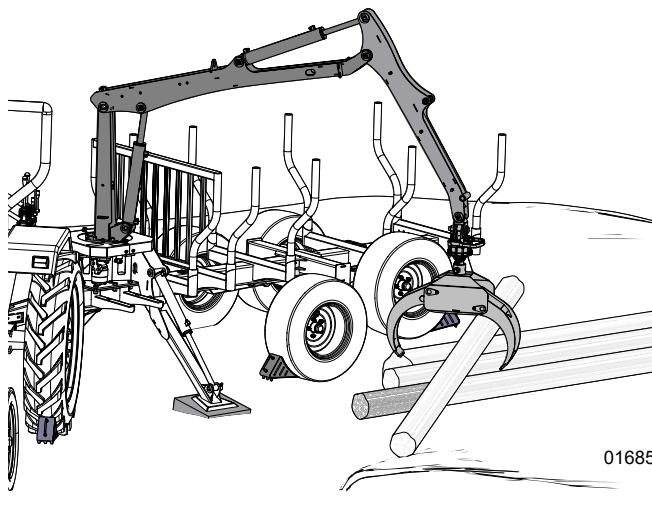

Fig. 47 – Setup

## 6.13 Transporting

**IMPORTANT!** LXT95 Log Loader / Trailer is not intended for use or transport on public roadways. Therefore, it does not include the required lights, reflectors and markings.

Equipment that is transported on a public roadway must comply with local laws that govern the safety and transport of machinery.

Before taking this machine on a public roadway, make sure it has the lighting, reflectors and markings required by your local transportation authority. Make sure they are in good working order.

### Transporting Safety

- Comply with Provincial / state and local laws governing safety and transporting of machinery on public roads.
- Do not exceed a safe travel speed. Slow down for rough terrain and cornering.
- Retract and fully lower boom and grapple in line with the frame before moving or transporting.
- Do not transport or move the grapple with the power pack engine on.
- Be sure the trailer is hitched positively to the towing vehicle and a retainer is used through the hitch mechanism.
- Always attach safety chain between the hitch and the towing vehicle.
- Inspect rims for dents or damage, check wheel lugs and tighten if required.
- Inspect tires for cuts or damage, check tire pressure and top up if required.
- Ensure your tow vehicle is fitted with the correct sized towing ball.
- Clean off all debris from the machine.
- Check that all the lights, reflectors and other lighting requirements are installed and in good working condition.
- Never allow riders on the machine.
- Be a safe and courteous driver. Always yield to oncoming traffic in all situations, including narrow bridges, intersections, and so on.
- Watch for traffic when near or crossing roadways.
- Do not drink and drive.
- Just before transport, perform a circle check to ensure everything is safe.
- Do not exceed a safe travel speed when transporting.

### LXT95 Off-road Trailers

1. Be sure the trailer is hitched positively to the vehicle and a retainer is used through the drawbar.
2. Make sure the Surge Brake is locked out (disengaged). See page 31 for more information.
3. Do not exceed 30 mph (50 km/h) safe travel speed. Slow down for rough terrain and cornering.
4. Do not exceed maximum load capacity of 5,000 lb (2 268 kg).

### LXT115 Highway Trailers

1. Check that trailer brakes are functioning properly.
2. Make sure your tow vehicle has the correct sized towing ball (2–5/16") and a retainer is used through the ball hitch latch. Articulating drawbar must be straight and drawbar pin installed.
3. Check that all reflectors and turn signal lights are installed and in good working condition.
4. Do not exceed 50 mph (80 km/h) maximum highway travel speed.
5. Do not exceed maximum load capacity of 11,500 lb (5 216 kg).

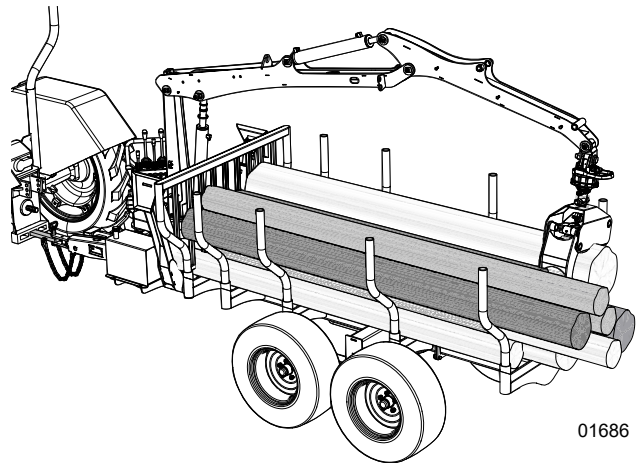

**Fig. 48**—Grapple Safe Position

## 6.14 Storage

### Storage Safety

- Store the unit in an area away from human activity.
- Do not let children to play on or around the stored machine.
- Store the unit in a dry, level area.
- If storing for long periods consult your engine owner's manual for safe storage.

After the season's use or when the machine will not be used for a period, completely inspect all major systems of the grapple. Replace or repair any worn or damaged components to prevent any unnecessary down time at the beginning of the next season.

Follow these steps before storing:

1. Unload all material from the machine.
2. Thoroughly clean the machine to remove all dirt, mud or debris.
3. Lubricate all grease fittings. Make sure all grease cavities have been filled with grease to remove any water residue from washing.
4. Apply a coat of heavy grease to exposed cylinder rams to prevent rusting.
5. Swing the boom straight out behind and install the boom lock pin.
6. Clamp the grapple to the back of the trailer frame.
7. Chock the wheels to prevent unintentional movement.
8. Inspect all moving parts for entangled material. Remove all entangled material.
9. Check the condition of the hydraulic components. Tighten or replace leaking fittings.
10. Stow hydraulic hose ends in storage brackets to keep them off the ground.
11. Touch up all paint nicks and scratches to prevent rusting.
12. Cover with a waterproof tarp if the machine cannot be placed inside.
13. Check tire pressure and top up if required.
14. Store in an area away from human activity.
15. Do not allow children to play around the stored unit.

### 6.14.1 Grapple / three-point hitch

Follow this procedure for grapple / L400, 3-point hitch equipped before storing:

1. Place blocks or planks under the stabilizers and grapple. Fully lower the three-point hitch.
2. Lower the grapple boom and stabilizers.
3. Stow hydraulic hose ends in storage brackets to keep them off the ground.
4. Unhook from tractor.
5. Cover with a waterproof tarp if the machine cannot be placed inside.

### 6.14.2 Power Pack

Add fuel stabilizer to the fuel tank, then operate the engine for 10 minutes so that the treated fuel has circulated through the system.

Review the engine owner's manual to prepare the engine for storage.

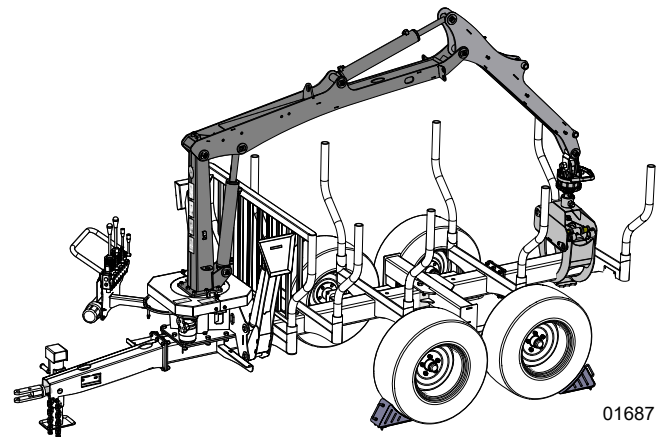

Fig. 49 – Grapple in Safe Position

### 6.14.3 Removal from Storage

1. Review Safety Rules starting on page 7.
2. Review Pre-start Checks on page 35.
3. Review engine manual if power-pack equipped. If stored for more than six months, warm the engine by operating for 2–3 minutes then change the oil. Refer to engine manual.

# 7. Service and Maintenance

## **WARNING!**

Risk of serious personal injury. Stop engine before performing ANY service or maintenance procedure. Reinstall all covers and shields removed before putting machine back into service.

W033

## **WARNING!**

Shut down the machine and allow it to cool before performing any service, maintenance, or inspection procedure. Engine components and oil may be hot enough to cause injury.

Make sure the machine is in a Safe Condition to work on. Review Maintenance Safety beforehand.

W041

Place the machine in a Safe Condition before performing any service, maintenance work or storage preparation by performing the following:

### Safe Condition

- Grapple is closed and resting on trailer
- Boom lock pin is installed
- Fuel valve is turned off (power pack equipped)
- Trailer load is secure
- Tow vehicle parking brake is applied. Engine stopped

- Follow good shop practices:
  - Keep service area clean and dry.
  - Be sure electrical outlets and tools are properly grounded.
  - Use adequate light for the job at hand.
- Never operate the tractor engine inside a closed building. The exhaust fumes may cause asphyxiation.
- Before working on this machine, shut off the engine, set the brake, and turn fuel valve off.
- Allow the machine to cool before performing maintenance. Components and oil may be hot enough to cause burn injury.
- Never work underneath equipment unless it is blocked securely.

- When performing any service or maintenance work always wear proper PPE for the job.
- Where replacement parts are necessary, genuine factory replacement parts must be used to restore equipment to original specifications. The manufacturer is not responsible for injuries or damages caused by use of unapproved parts or accessories.
- Inspect and tighten all bolts, nuts and screws. Check that all electrical and hydraulic connections are properly secured to ensure machine is in a safe working condition.
- After completing a service procedure, make sure all covers and shields are reinstalled.
- When cleaning any parts, do not use gasoline or diesel fuel. Use a regular cleanser.
- Always use proper tools in good condition.
- A fire extinguisher and first aid kit should be kept readily accessible while performing maintenance on this equipment.

## 7.1 Fluids and Lubricants

### 1. Engine Oil

SAE 10W-30 is recommended for general use. Refer to the engine manufacturer's manual for maintenance and service information.

### 2. Grease

Use an SAE multi-purpose high temperature grease with extreme pressure (EP) performance. Also acceptable is an SAE multipurpose lithium-based grease.

### 3. Engine Fuel

This engine is certified to operate on unleaded gasoline. Refer to the engine manual.

### 4. Hydraulic Oil

Use Dexron® III ATF for all operating conditions. Dexron VI or Mercon® are acceptable substitutes.

### 5. Storing Lubricants

Your machine can operate at top efficiency only if clean lubricants are used. Use clean containers to handle all lubricants. Store them in an area protected from dust, moisture, and other contaminants.

## 7.2 Grease Points

Use the table below and the following illustrations to locate grease points on the log boom, trailer, and grapple.



Look for this decal on your machine. It indicates a grease point and the interval in hours.

1. Use a hand-held grease gun. Wipe grease fitting with a clean cloth before greasing to avoid injecting dirt and grit.
2. Replace and repair broken fittings immediately.
3. If fitting does not take grease, remove and clean thoroughly. Also, clean lubricant passageway. Replace fitting if necessary.

Location	Every 50 hours of operation
1	Stabilizer and stabilizer cylinder
2	Main Boom Hoist Cylinder
3	Main Boom Pivot
4	Dipper Cylinder
5	Dipper Cylinder Links
6	Boom Nose
7	Slew Assembly Ring Gear
8	Adjustable Tandem Slide
9	Tandem Axle Rocker—one fitting per side
10	Clevis hitch
11	Rotator
12	Grapple
13	Winch Drive (Option)

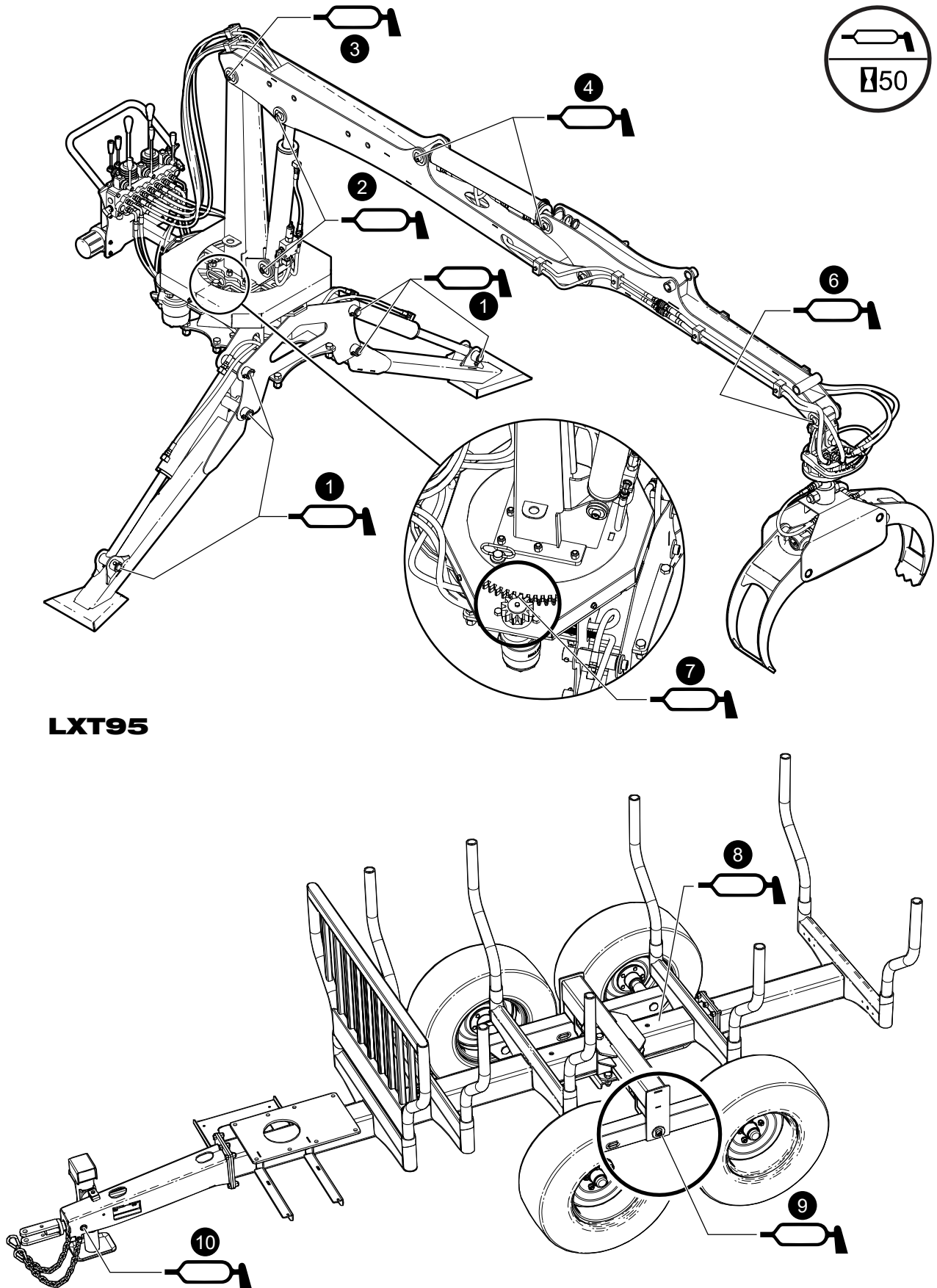
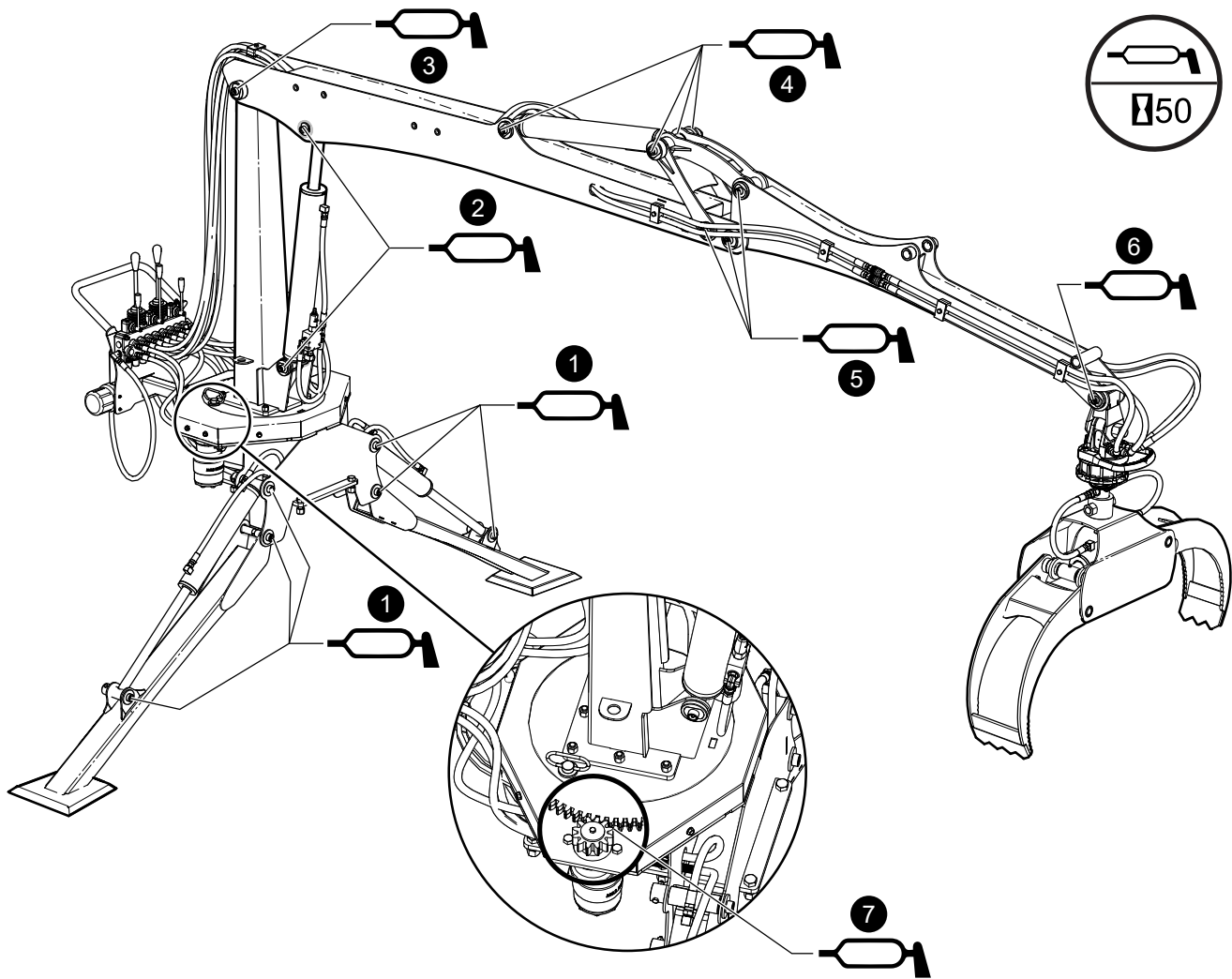

Fig. 50—LXT95 Log Boom and Trailer Grease Points



**LXT115**

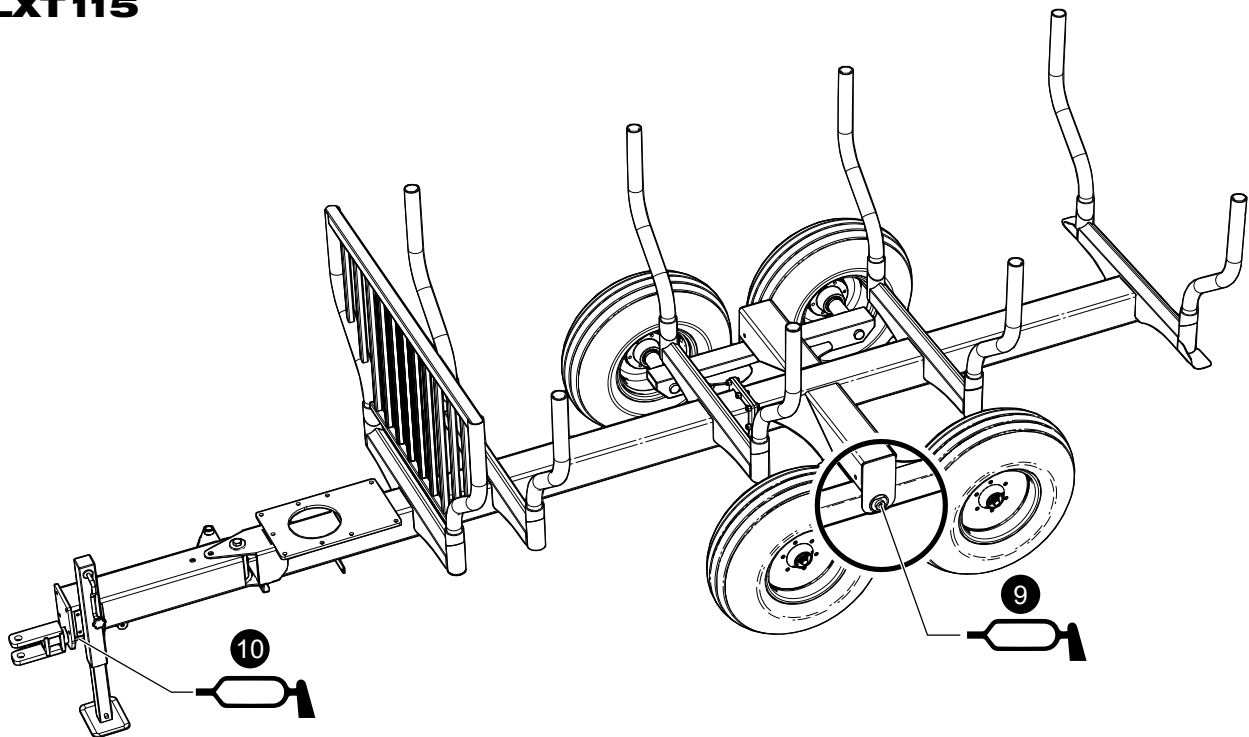

Fig. 51 – LXT115 Log Boom and Trailer Grease Points



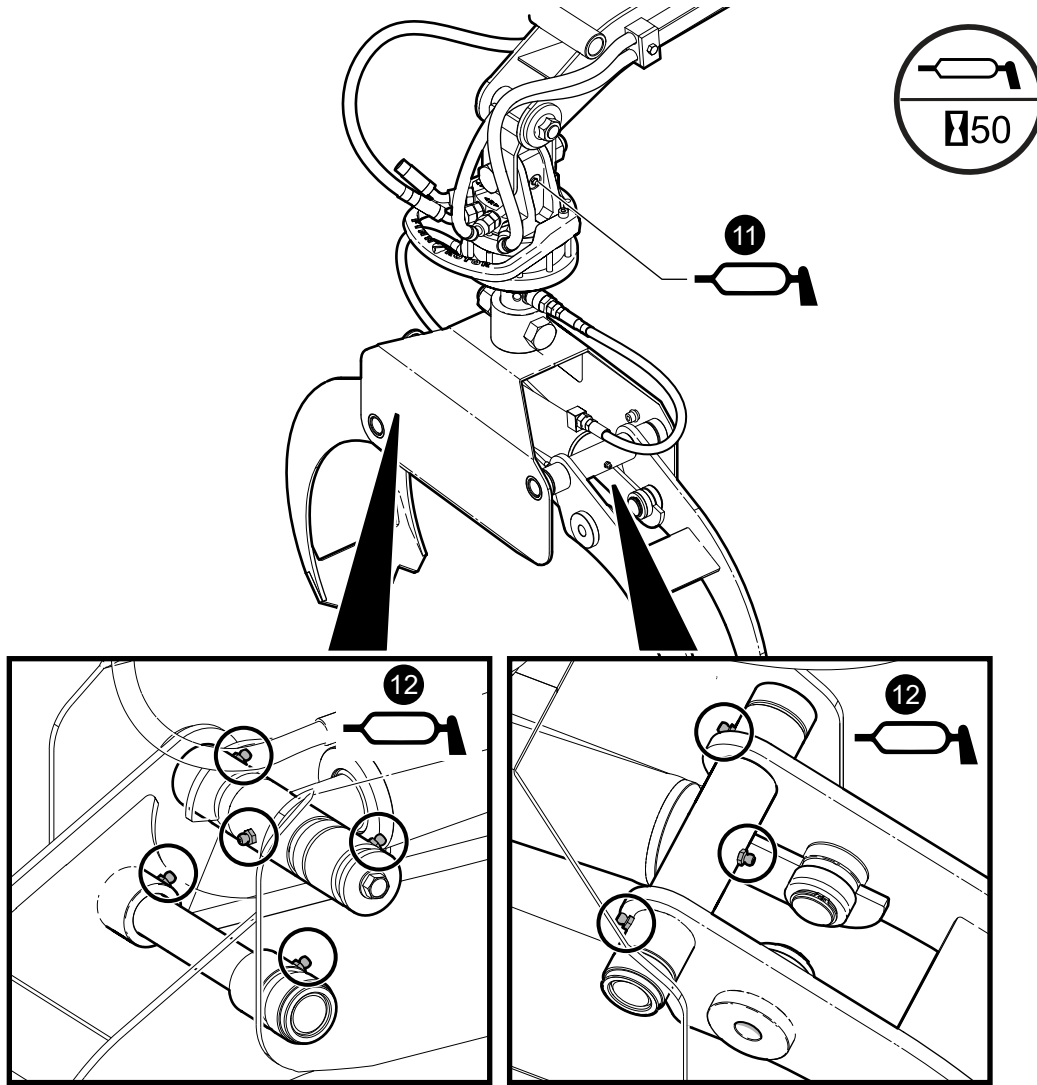

Fig. 52—Log Grapple Grease Points

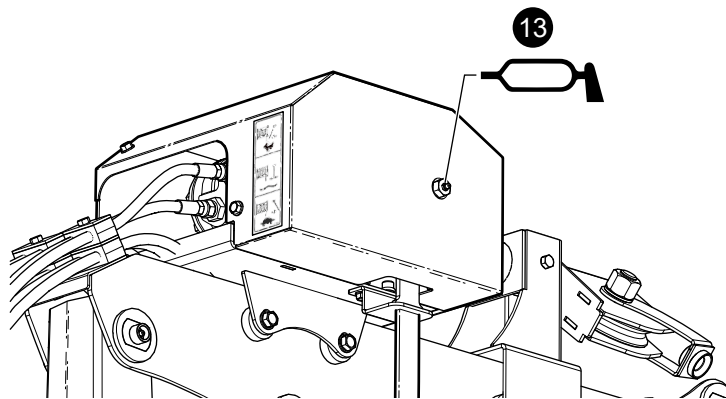

Fig. 53—Winch Option Grease Point

## 7.3 Maintenance Schedule

Refer to your engine instruction manual for specific maintenance instructions / requirements.

Perform at time shown or hour interval, whichever comes first. <b>Item</b>	<b>Every 8 hours or Daily</b>	<b>Every 50 hours or Annually</b>	<b>Every 100 hours or Annually</b>	<b>Reference</b>
Winch Option—Check Rope Condition	●			
Check Hydraulic Hoses, Fittings	●			
Check that all Fasteners are Secure	●			
Check Wheel Lug Nut Torque	●			See page 60
Check Engine Oil Level	●			See page 36
Check Fuel Level	●			See page 36
Grease Machine		●		
Check Hydraulic Oil Level		●		See page 52
Check Engine Air Filter		●		See page 51
Change Engine Oil		●		See engine manual
Repack Axle Bearings			●	
Check Tire Pressure			●	See Tire Sidewall
Change Hydraulic Oil and Filter			●	See page 53
Change Engine Air Filter			●	See engine manual
Clean Machine			●	

## 7.4 Engine Air Cleaner

**Check air filter every 50 hours of operation. Change air filter elements at 100 hours of operation or annually.**



Refer to the engine manual for information on servicing the air cleaner.

A dirty air filter can restrict air flow to the carburetor, reducing engine performance. If the engine is operated in very dusty areas, clean the air filter more often than specified.

**IMPORTANT! Operating the engine without an air filter, or with a damaged air filter, can allow dirt to enter the engine, causing rapid engine wear. This type of damage is not covered by Warranty.**

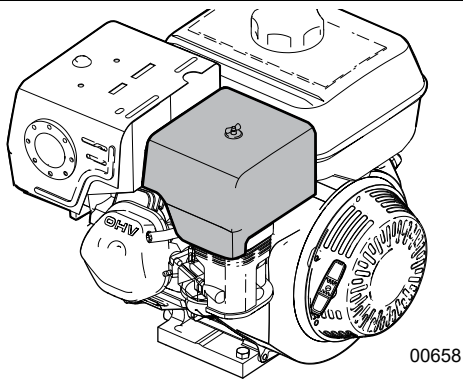

**Fig. 54**—Engine Air Cleaner

## Inspection

Remove the air cleaner cover and inspect the filter elements. Clean or replace dirty filter elements. Always replace damaged filter elements.

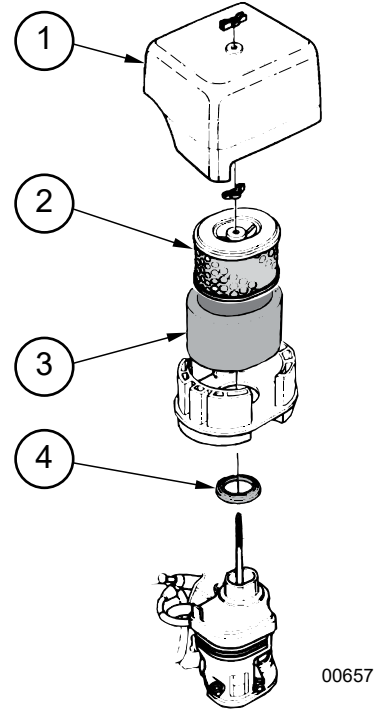

**Fig. 55**—Honda™ GX270 Air Cleaner

1. Air Cleaner Cover
2. Paper Filter Element
3. Foam Filter Element
4. Gasket

## 7.5 Hydraulic Oil

### Check hydraulic oil level every 50 hours.

The hydraulic tank on power pack is located opposite the engine beside the trailer tongue. It has a cap / dipstick that indicates the level of oil in the tank.

The quality of the oil should be inspected every 50 hours. If the oil is dirty or smells burnt, it should be replaced.

When checking the oil level—

1. Make sure the machine is in **safe condition** to work on. See page 7.
2. Allow the engine and muffler to cool.
3. Clean area around fill cap and remove cap.
4. Using a clean funnel, fill the tank according to the oil dipstick:
  - Never fill the oil tank above the full (F) line at the top of the dipstick.
  - Do not run the machine with the oil level below the bottom (L) line at the bottom of the dipstick.
  - Reservoir capacity is 4.6 US gal (17.5 L).
  - Use Dexron® III ATF for all operating conditions. Dexron VI or Mercon® are acceptable substitutes.
  - Install fill cap securely and wipe up any spilled fuel.

### Check level after changing filters or servicing hydraulic components.

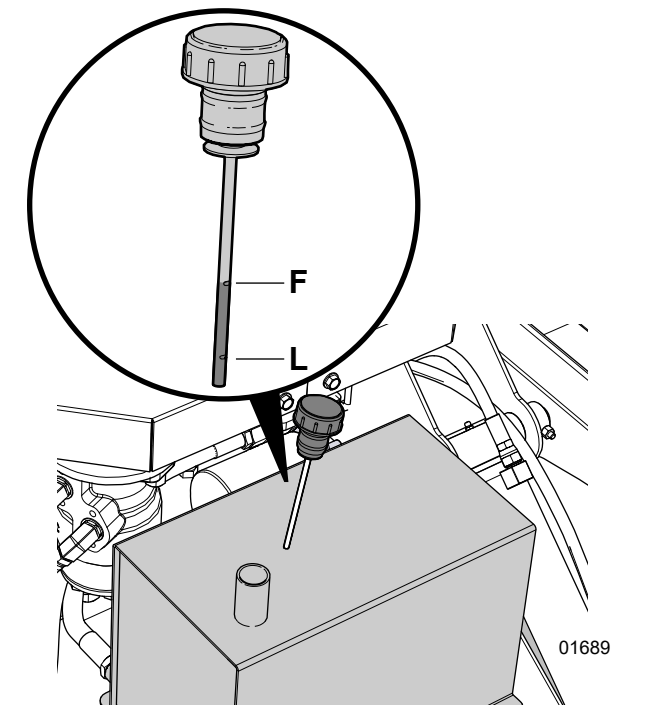

Fig. 56—Hydraulic Oil Level Check

### 7.5.1 Hydraulic Oil, Changing

The drain plug is located at the bottom of the hydraulic tank. Allow the machine to cool before changing the oil. Hot oil can cause burns if it contacts exposed skin. It is best to change oil while the machine is warm to keep the contaminants in suspension.

1. Make sure the machine is in **safe condition** to work on. See page 7.
2. Have a drain pan ready of the correct capacity.
3. Clean area around drain and remove the plug.
4. Allow the oil to drain, then flush the tank.
5. Install the plug and refill the tank with oil.
6. Dispose of used oil in an environmentally acceptable manner.

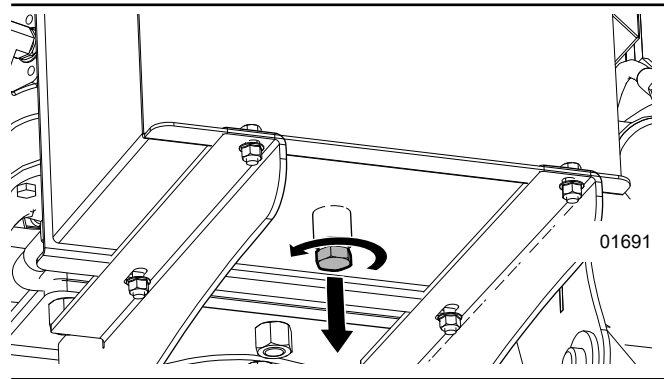

Fig. 57—Hydraulic Tank Drain plug

## 7.5.2 Hydraulic Filter, Changing

Change the hydraulic oil every 100 hours or annually.

The filter is located below the control panel. Follow this procedure to change out the filter:

Allow the machine to cool before beginning. Hot oil can cause burns if it contacts exposed skin. Have a drain pan ready to catch any dripping oil.

1. Make sure the machine is in **safe condition** to work on. See page 7.
2. Clean area around filter, then remove the filter.
3. Apply a light coat of oil to the O-ring and install the replacement filter. Snug up by hand and then tighten a further 1/4-turn.
4. Start up the machine and operate the hydraulic functions for 1–2 minutes.
5. Check filter head for oil leaks. If leaks are found around the filter, tighten slightly.
6. Check hydraulic reservoir oil level. Top up as required.
7. Dispose of used oil filter in an environmentally acceptable manner.

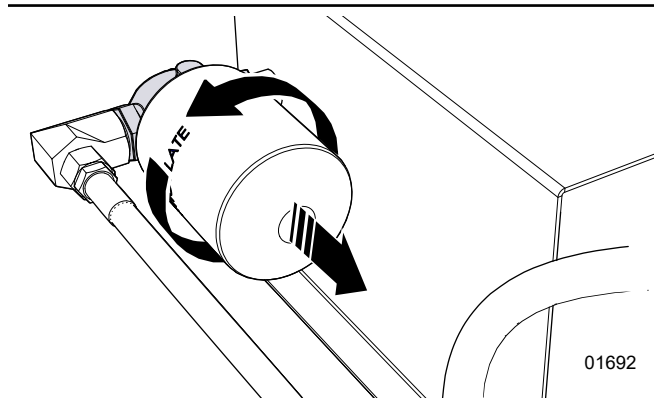

Fig. 58—Hydraulic Oil Filter

## 7.6 LXT95 Surge Brakes

**IMPORTANT! Repair and maintenance of the brakes should be performed by a qualified mechanic.**

Refer to the Dexter® service manual for further information on brake maintenance and adjustments [www.dexteraxle.com/Resources](http://www.dexteraxle.com/Resources).

When adjusting or repairing to the brakes, be aware there are a left- and right-hand brake assemblies.

Trailer brakes must be inspected and serviced immediately if a loss of performance is indicated. With normal use, servicing at one-year intervals is usually adequate. With increased usage, this work should be done more frequently as required.

**After replacement of brake shoes and linings, the brakes must be re-burnished to seat in the new components.** This should be done by applying the brakes 20 to 30 times from an initial speed of 40 mph (65 km/h) then slowing to 20 mph (32 km/h). Allow ample time for brakes to cool between applications. This procedure allows the brake shoes to seat in to the drum surface.

### Wheel Cylinders

Inspect for leaks and smooth operation. Clean with brake cleaner and flush with fresh brake fluid. Hone or replace as necessary.

### Brake Lines

Check for cracks, kinks, or blockage. Replace as necessary. Flush with fresh brake fluid. Bleed system to remove all air.

### Shoes and Linings

Replacement is necessary if the lining is worn (less than 1/16" [1.5 mm]), contaminated with grease or oil, or abnormally scored or gouged. Hairline heat cracks are normal in bonded linings and should not be cause for concern.

When replacement is necessary, it is important to replace both shoes on each brake and both brakes of the same axle. This helps retain the braking balance. Before reassembling, apply a light film of grease or anti-seize compound on the brake anchor pin, the actuating arm bushing and pin, and the areas on the backing plate that are in contact with the brake shoes.

### Hardware

Check all hardware. Check shoe return spring, hold down springs and adjuster for stretch or wear. Replace as required.

## Brake Adjustment

1. Raise the trailer and secure on adequate jack stands. Make sure the wheels and drums can rotate freely.
2. Locate and remove the adjusting hole cover from the slot on the brake backing plate.
3. With a screwdriver or standard adjusting tool, rotate the star wheel of the adjuster assembly to expand the brake shoes. Adjust the brake shoes out until the pressure of the linings against the drum makes the wheel very difficult to turn.
4. Then rotate the star wheel in the opposite direction until the wheel turns freely with a slight lining drag.
5. Replace the adjusting hole cover and lower the wheel to the ground.
6. Repeat the above procedure on all brakes. For best results, the brakes should all be set at the same clearance.

Most of the brake components are very similar to those used in electric brakes, and maintenance is comparable for the hub and drum, shoes and linings, and bearings.

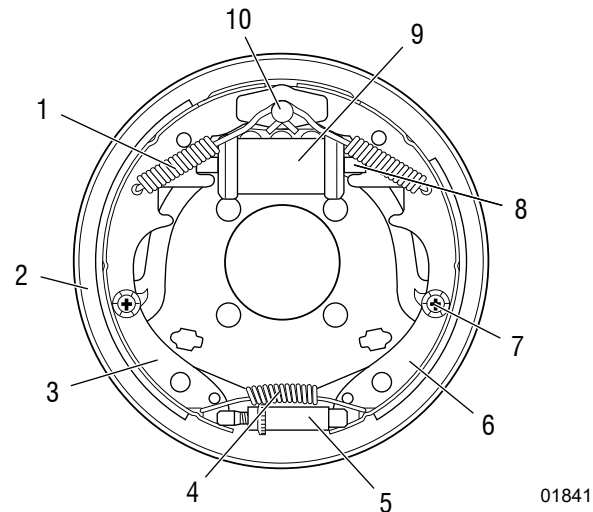

**Fig. 59**—Hydraulic Drum Brake

- |                      |                             |
|----------------------|-----------------------------|
| 1. Retractor Springs | 6. Primary Shoe             |
| 2. Backing Plate     | 7. Hold Down Spring         |
| 3. Secondary Shoe    | 8. Actuating Pin            |
| 4. Adjuster Spring   | 9. Hydraulic Cylinder Wheel |
| 5. Adjuster Assembly | 10. Anchor Post             |

## 7.7 LXT115 Electric Brakes

**IMPORTANT! Repair and maintenance of the brakes should be performed by a qualified mechanic.**

Refer to the Dexter® service manual for further information on brake maintenance and adjustments [www.dexteraxle.com/Resources](http://www.dexteraxle.com/Resources).

When adjusting or repairing the brakes, be aware there are a left- and right-hand brake assemblies.

Trailer brakes must be inspected and serviced immediately if a loss of performance is indicated. With normal use, servicing at one-year intervals is usually adequate. With increased usage, this work should be done more frequently as required.

**After replacement of brake shoes and linings, the brakes must be re-burnished to seat in the new components.** This should be done by applying the brakes 20 to 30 times from an initial speed of 40 mph (65 km/h) then slowing to 20 mph (32 km/h). Allow ample time for brakes to cool between applications. This procedure allows the brake shoes to seat in to the drum surface.

### Shoes and Linings

Replacement is necessary if the lining is worn (less than 1/16" [1-1/2 mm]), contaminated with grease or oil, or abnormally scored or gouged. Hairline heat cracks are normal in bonded linings and should not be cause for concern.

When replacement is necessary, it is important to replace both shoes on each brake and both brakes of the same axle. This helps retain the braking balance.

### Magnets

The electric brakes are equipped with electromagnets designed to provide the proper input force and friction characteristics. Magnets should be inspected and replaced if worn unevenly or abnormally. Use a straight edge to check magnet flatness. Even if wear is normal the magnets should be replaced if any part of the magnet coil has become visible through the friction material facing of the magnet.

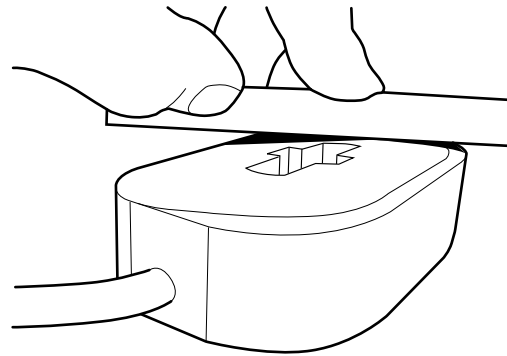
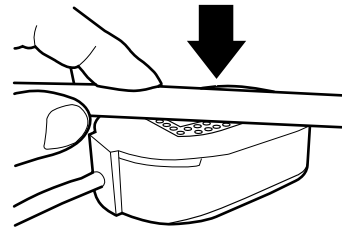

01842

**Fig. 60**—Use a Straight Edge to Check Magnet Flatness

It is also recommended that the drum armature surface be re-faced when replacing magnets. Magnets should also be replaced in pairs (both sides of the axle).

### Hardware

Check all hardware. Check shoe return spring, hold down springs and adjuster for stretch or wear. Replace as required.

### Brake Adjustment

1. Raise the trailer and secure on adequate jack stands. Make sure the wheels and drums can rotate freely.
2. Locate and remove the adjusting hole cover from the slot on the brake backing plate.
3. With a screwdriver or standard adjusting tool, rotate the star wheel of the adjuster assembly to expand the brake shoes. Adjust the brake shoes out until the pressure of the linings against the drum makes the wheel very difficult to turn.
4. Then rotate the star wheel in the opposite direction until the wheel turns freely with a slight lining drag.
5. Replace the adjusting hole cover and lower the wheel to the ground.
6. Repeat the above procedure on all brakes. For best results, the brakes should all be set at the same clearance.

## 7.8 Winch Accessory

### CAUTION!

**Avoid the risk of rope failure. Do not replace rope with one that is not approved for use on this winch. Rope properties may be unknown and failure could result. Refer to the parts manual for replacement rope type.**

W094

### Synthetic Rope Use

If you winch a lot and find wire rope can be a problem, synthetic can be a great option since it is lightweight and easy to handle. It does not develop sharp burrs like steel rope. Synthetic rope can require more maintenance, however. It is more prone to abrasion. It should be regularly inspected for frays or other damage caused by UV, chemicals, and general use.

### WARNING!

**Synthetic rope that fails under tension can snap back with great force causing injury or death. Avoid sudden jerks, quick starts or stops. Start slowly and smoothly. Replace if kinked, badly frayed, has knots, cuts, or broken strands.**

W095

### Rope inspection

It is a good idea to check the entire rope for wear and re spool it neatly after every use. Check the winch rope for any cut strands, fraying parts, abrasion, or heat damage from the winch. After use, all winch lines will get a little fuzzy from abrasion. This is normal, but **if an entire strand is cut the winch line needs to be replaced or fixed.** For the winch line to work properly and maintain its strength, all strands must be intact.

### Handling

Synthetic winch rope generally lies on the surface of mud or water instead of becoming completely submerged like a steel rope, making winching through these conditions easier.

Besides being the lightweight option for winch ropes, synthetic rope has the added benefit of being extremely flexible. This allows it to be handled much easier than a steel winch rope, especially when free-spooling and hauling around. It also prevents the synthetic line from kinking like the steel rope is prone to if not handled properly.

### Strength

Steel winch rope can stand more abrasion. It can be pulled over obstacles and rough terrain without fear of damage to the rope itself. If winching primarily in muddy, rocky, or sandy conditions a steel rope may be a better fit.

A synthetic winch rope, while having more than enough strength to pull the load without snapping, is very susceptible to damage from rubbing up against or sliding along rugged surfaces.

### Weather

A steel winch rope is more resilient to different weather conditions than a synthetic one. Inspect the rope from time to time to ensure the steel strands have not rusted.

There are several environmental factors that adversely affect synthetic rope—heat and direct sunlight being two of its worst enemies. Both heat and UV exposure break down the fibers of the synthetic rope weakening it and making it brittle over time. Frequent use in mud, dirt and sandy conditions can also damage a synthetic rope if it is not properly cleaned and cared for.

### Cleaning Synthetic Rope

When dirt and grit become lodged in between the strands of the winch line they cause abrasion to the fibers when the winch line is put under a load. Over time this can cause a breakdown in the integrity and strength of the rope.

Wash winch rope if it gets dirty by unspooling the entire line from the winch and lay it on a clean surface. Once the line is laid out, rinse it well with water from a hose.

To really get the strands free of dirt and grit, fill a bucket with water and mild soap. Push together on the rope to open the strands up and rinse in the water. Run the entire length of the winch line through the water until it is cleaned.



## 8. Troubleshooting

The following table lists some problems that may be encountered, with possible causes and solutions.

If a problem persists after reading through the Troubleshooting section, contact the local dealer, distributor or Wallenstein Equipment. Have the machine serial number ready.

### Engine related issues

Refer to the engine owner's manual found in the manual tube.

Problem	Cause	Solution
<b>Cylinder rods move slowly or do not move (main boom, dipper boom, grapple, stabilizers).</b>	No pressurized hydraulic oil.	Oil filter plugged. Change filter. Low hydraulic oil level. Add oil.
	Hydraulic hoses connected incorrectly at grapple.	Check color code and match connections.
	Not enough oil flow.	Flow control set too low. Set control higher for more flow.
	Low engine speed.	Make sure engine choke is off. Check throttle is correctly set.
<b>Jerky cylinder movement</b>	Leak in hydraulic system. Air in hydraulic circuit.	Tighten all hydraulic connections.
<b>Control valve handle does not go to neutral when released.</b>	Control valve spool return springs faulty.	Replace.
	No pressurized hydraulic oil.	Oil filter plugged. Change filter. Low hydraulic oil level. Add oil.
	Control may be damaged.	Control may need service or be replaced. Call service technician.
<b>Leaking hydraulic hose.</b>	Hose worn or damaged.	Replace.
<b>Leaking cylinder.</b>	Seals worn.	Seal replacement may be required. Call service technician.
<b>Hydraulic controls (from tractor) behave erratically.</b>	Hydraulic circuit type on tractor does not match boom/grapple control valve type (open center—closed center).	Call service technician.
<b>Boom drifts down.</b>	Leaking cylinder seals.	Replace seals.
	Counterbalance valve defective.	Repair or replace valve.
<b>Boom does not rotate or rotates slowly.</b>	Boom lock pin is still in place.	Remove.
	No pressurized hydraulic oil.	Oil filter plugged. Change filter. Low hydraulic oil level. Add oil. Flow control set too low. Adjust.
	Hydraulic hoses switched.	Switch input / output hydraulic hose connections.
	Low engine speed.	Make sure engine choke is off. Check throttle is correctly set.
	Boom slew assembly gears jammed.	Clear debris from gears
	Boom slew assembly requires lubrication.	Grease boom slew assembly.
<b>Brakes not functioning on log trailer.</b>	Brake lockout engaged (LXT95).	Disengage lockout.
	Trailer connector, wiring issue (LXT115).	Inspect connectors and wiring. Clean contacts, replace broken wires.
	Broken or leaking brake line (LXT95).	Replace brake line.
	Brakes not adjusted correctly.	Check and adjust.
	Grease or oil on brakes linings.	Clean or replace.

## 9. Specifications

### 9.1 Machine Specifications<sup>1</sup>

Model	LXT95	LXT115
Load Capacity	5,000 lb (2 268 kg)	11,500 lb (5 216 kg)
Lift Capacity	800 lb (363 kg)	1,200 lb (544 kg)
Engine	196 cc Honda™ GX200	270 cc Honda™ GX270
Grapple Opening	3"–30" (8 cm–76 cm)	
Grapple Rotation	360°	
Boom Rotation	270°	
Trailer Bed Length	96" (244 cm)	132" (335 cm)
Sliding Axle	Hydraulic	N/A
Horizontal Reach	9'–6" (290 cm)	11'–6" (351 cm)
Vertical Reach (ground to closed grapple)	12'–11" (394 cm)	15'–5" (470 cm)
Stabilizer Spread	7'–5" (226 cm)	8'–11" (272 cm)
Main Boom Lift Cylinder Diameter	2-1/2" (6 cm)	
Dipper Cylinder Diameter	2-1/2" (6 cm)	
Stabilizer Cylinder Diameter	2" (5 cm)	
Ground Clearance	14" (36 cm)	17" (43 cm)
Tires	27 x 10.5 x 15 – 8 ply	ST235-80R16LRE
Ball Hitch Size	2"	2-5/16"
Brakes	Surge	Electric
Tongue Weight (Trailer empty with log loader)	200 lb–465 lb (91 kg–211 kg)	480 lb (218 kg)
Tongue Weight (Trailer empty with log loader and power pack)	250 lb–515 lb (114 kg–234 kg)	555 lb (252 kg)
Trailer Weight (Unloaded)	1,650 lb (748 kg)	2,470 lb (1 120 kg)
Dimensions (L x W x H)	161" x 64" x 58" (409 cm x 163 x 147 cm)	198" x 68" x 60" (503 cm x 173 cm x 152 cm)

N/A–Not available

<sup>1</sup> Specifications subject to change without notice

### 9.2 Accessories & Options

After Market Accessories
Auger Kit—6", 9" (15 cm, 23 cm)
Bucket Kit—9", 12", 15", 18" (23 cm, 30 cm, 38 cm, 46 cm)
Dump Box
Expanded Metal Flat Deck
Hydraulic Winch

Available Options
Tractor Hydraulic Kit—Use the tractor hydraulic system to power the grapple/boom system.

## 9.3 Common Bolt Torque Values

### Checking Bolt Torque

The tables shown give correct torque values for various bolts and capscrews. Tighten all bolts to the torque values specified in the table, unless indicated otherwise. Check tightness of bolts periodically.

**IMPORTANT!** If replacing hardware, use fasteners of the same grade.

**IMPORTANT!** Torque figures indicated in the table are for non-greased or non-oiled threads. Do not grease or oil threads unless indicated otherwise. When using a thread locker, increase torque values by 5%.

 **NOTE:** Bolt grades are identified by their head markings.

Imperial Bolt Torque Specifications						
Bolt Diameter	Torque Value					
	SAE Gr. 2		SAE Gr. 5		SAE Gr. 8	
	lbf•ft	N•m	lbf•ft	N•m	lbf•ft	N•m
1/4"	6	8	9	12	12	17
5/16"	10	13	19	25	27	36
3/8"	20	27	33	45	45	63
7/16"	30	41	53	72	75	100
1/2"	45	61	80	110	115	155
9/16"	60	95	115	155	165	220
5/8"	95	128	160	215	220	305
3/4"	165	225	290	390	400	540
7/8"	170	230	420	570	650	880
1"	225	345	630	850	970	1320



Metric Bolt Torque Specifications				
Bolt Diameter	Torque Value			
	Gr. 8.8		Gr. 10.9	
	lbf•ft	N•m	lbf•ft	N•m
M3	0.4	0.5	1.3	1.8
M4	2.2	3	3.3	4.5
M6	7	10	11	15
M8	18	25	26	35
M10	37	50	52	70
M12	66	90	92	125
M14	83	112	116	158
M16	166	225	229	310
M20	321	435	450	610
M30	1,103	1 495	1,550	2 100



## 9.4 Hydraulic Fitting Torque

### Tightening Flare Type Tube Fittings

1. Check flare and flare seat for defects that might cause leakage.
2. Align tube with fitting before tightening.
3. Hand-tighten swivel nut until snug.
4. To prevent twisting the tube, use two wrenches. Place one wrench on the connector body and tighten the swivel nut with the second. Torque to values shown.

If a torque wrench is not available, use the FFFT (Flats From Finger Tight) method.

Hydraulic Fitting Torque					
Tube Size OD	Hex Size Across Flats	Torque value		Flats From Finger Tight	
		lbf•ft	N•m	Flats	Turns
Inches	Inches				
3/16	7/16	6	8	2	1/6
1/4	9/16	11–12	15–17	2	1/6
5/16	5/8	14–16	19–22	2	1/6
3/8	11/16	20–22	27–30	1-1/4	1/6
1/2	7/8	44–48	59–65	1	1/6
5/8	1	50–58	68–79	1	1/6
3/4	1-1/4	79–88	107–119	1	1/8
1	1-5/8	117–125	158–170	1	1/8

Values shown are for non-lubricated connections.

## 9.5 Wheel Lug Torque

It is extremely important safety procedure to apply and maintain proper wheel mounting torque on your trailer axle. Torque wrenches are the best method to assure the proper amount of torque is being applied to a fastener.

Wheel lugs should be torqued before first road use and after each wheel removal. Check and re torque after the first 10 miles (16 km), 25 miles (40 km), and again at 50 miles (80 km). Check periodically thereafter.

### WARNING!

**Wheel lug nuts must be installed and kept at the proper torque value to prevent loose wheels, broken studs, or possible separation of wheels from axle.**

- Start all lug nuts onto the threads by hand.
- Tighten lug nuts in stages, following the pattern shown in the Wheel Lug Nut Torque table.

Wheel Lug Nut Torque				
Wheel Size	Units	1st Stage	2nd Stage	3rd Stage
8"	lbf•ft N•m	12–20 16–26	30–35 39–45.5	45–55 58.5–71.5
12"	lbf•ft N•m	20–25 26–32.5	35–40 45.5–52	50–60 65–78
13"	lbf•ft N•m	20–25 26–32.5	35–40 45.5–52	50–60 65–78
14"	lbf•ft N•m	20–25 26–32.5	50–60 65–78	90–120 117–156
15"	lbf•ft N•m	20–25 26–32.5	50–60 65–78	90–120 117–156
16"	lbf•ft N•m	20–25 26–32.5	50–60 65–78	90–120 117–156

Wheel Lug Torque Pattern

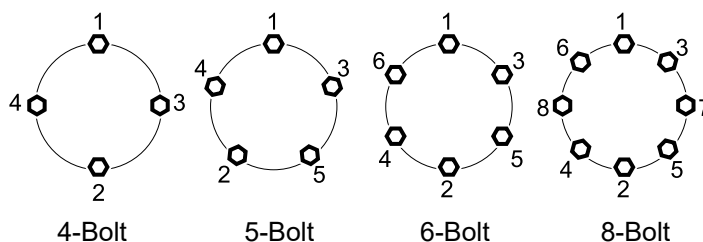

## 10. Product Warranty



### LIMITED WARRANTY

Wallenstein products are warranted to be free of defects in materials and workmanship under normal use and service, for a period of

**Five Years for Consumer Use**

**Two Years for Commercial/Rental Use**

from the date of purchase, when operated and maintained in accordance with the operating and maintenance instructions supplied with the unit. Warranty is limited to the repair of the product and/or replacement of parts.

This warranty is extended only to the original purchaser and is not transferable.

Repairs must be done by an authorized dealer. Products will be returned to the dealer at the customer's expense. Include the original purchase receipt with any claim.

**This warranty does not cover the following:**

- 1) Normal maintenance or adjustments
- 2) Normal replacement of wearable and service parts
- 3) Consequential damage, indirect damage, or loss of profits
- 4) Damages resulting from:
  - Misuse, negligence, accident, theft or fire
  - Use of improper or insufficient fuel, fluids or lubricants
  - Use of parts or aftermarket accessories other than genuine Wallenstein parts
  - Modifications, alteration, tampering or improper repair performed by parties other than an authorized dealer
  - Any device or accessories installed by parties other than an authorized dealer
- 5) Engines. Engines are covered by the manufacturer of the engine for the warranty period they specify. For the details of your engine warranty, see your engine owner's manual. Information about engine warranty and service is also available in the FAQ section at [www.wallensteinequipment.com](http://www.wallensteinequipment.com)

# 11. Alphabetical Index

<b>A</b>		<b>I</b>	
Air Cleaner Inspection.....	51	Ignition Switch.....	26
Articulated Trailer Tongue .....	29	Information Decals .....	18
<b>B</b>		<b>L</b>	
Bolt torque.....	59	L400 Log Boom/Grapple Three Point Hitch Adaptor.....	23
Braking Systems .....	31	Lubricants.....	45
Break-in.....	35	<b>M</b>	
Bunk Posts.....	28	Machine Break-In .....	35
<b>C</b>		Machine Components .....	20
Checking Bolt Torque.....	59	Machine Setup .....	33
Cleaning Synthetic Rope.....	56	Maintenance Decals.....	6
Controls.....	24	Maintenance Schedule.....	50
Main Directional Control Valve.....	24	<b>O</b>	
Operator Console Swivel.....	24	Operating Instructions	
<b>E</b>		Before Start-up .....	34
Engine.....	45	Engine Oil Level Check .....	36
Engine Air Cleaner .....	51	Fuel Level Check .....	36
Engine Choke Lever.....	26	Load Distribution.....	38
Engine Controls.....	26	Loading.....	39
Choke Lever .....	26	Operating Hints.....	42
Fuel Shut-off Valve .....	26	Pre-operation Checks .....	35
Ignition Switch.....	26	Starting the Engine .....	37
Recoil Starter.....	27	Unloading and Stacking Logs .....	40
Throttle Lever.....	27	Winching Safety.....	11
Engine Fuel.....	45	Operating Safety .....	34
Engine Oil.....	45	Operation .....	34
Engine Oil Level Check.....	36	Operator Safe Area .....	12
Equipment Safety Guidelines.....	8	<b>P</b>	
<b>F</b>		Pre-operation Checks .....	35
Familiarization.....	19	<b>R</b>	
Job Site Familiarization.....	19	Refueling.....	36
Operator Orientation .....	19	Replacing Damaged Safety Signs .....	18
Training.....	19	<b>S</b>	
Fuel Level – Checking.....	36	Safe Condition.....	9, 45
Fuel Shut-off Valve.....	26	Safety .....	7
<b>G</b>		Equipment Safety Guidelines .....	8
Gas Motor Safety .....	10	Gas Motor Safety.....	10
Grapple Boom Safety.....	12	How to Install Safety Signs.....	18
Grease Points .....	46	Hydraulic Safety.....	9
Grease Type.....	45	Operating Safety.....	34
<b>H</b>		Safe Condition .....	9
Hydraulic Filter, Changing.....	53	Safety Alert Symbol .....	7
Hydraulic Fitting Torque .....	60	Safety Training.....	9
Hydraulic Oil.....	45	Signal Words .....	7
Hydraulic Oil, Changing .....	52	Storage Safety .....	44
Hydraulic Power Pack.....	26	Tire Safety .....	10
Engine Controls .....	26	Welding Safety.....	10
Hydraulic Reservoir.....	27	Safety Alert Symbol.....	7
Hydraulic Sliding Tandem Axle.....	28	Safety Signs	
Decreasing trailer tongue weight .....	29	Safety Sign Locations .....	15
Increasing trailer tongue weight.....	29	Safety signs, installing.....	18
Hydraulic Winch Option.....	30	Safety Training .....	9
Control Valve .....	30	Serial number.....	5
		Service and Maintenance.....	45
		Hydraulic Oil .....	52

LXT95 Surge Brakes .....	54
LXT115 Electric Brakes .....	55
Maintenance Schedule .....	50
Rope Replacement .....	56
Storing Lubricants.....	45
Sign-off form.....	14
Specifications .....	58
Accessories .....	58
Common Bolt Torque Values .....	59
Hydraulic Fitting Torque .....	60
Machine Specifications .....	58
Wheel Lug Torque.....	60
Starter .....	27
Stopping .....	38
Stopping in an Emergency .....	38
Storage.....	44
Storage Safety .....	44
Surge Brake System Lockout.....	32
Synthetic Rope	
Cleaning.....	56
Handling.....	56
Rope inspection .....	56
Strength .....	56
Weather .....	56

## T

Throttle Lever .....	27
Trailer Brake Adjustment.....	54
Transporting .....	43
Transporting Safety .....	43
Troubleshooting Guide .....	57

## U

Understanding Safety Decals.....	15
----------------------------------	----

## W

Warranty.....	61
Welding Safety .....	10
Wheel Lug Torque .....	60
Winch Accessory.....	56
Synthetic Rope Use .....	56
Winch Safety .....	11
Work Zone Arrangement.....	12



[www.wallensteinequipment.com](http://www.wallensteinequipment.com)