

PARTS MANUAL

Serial Number 2E9US1117FS040138 & Up

BXMT4224 **TRAILER CHIPPER-SHREDDER**

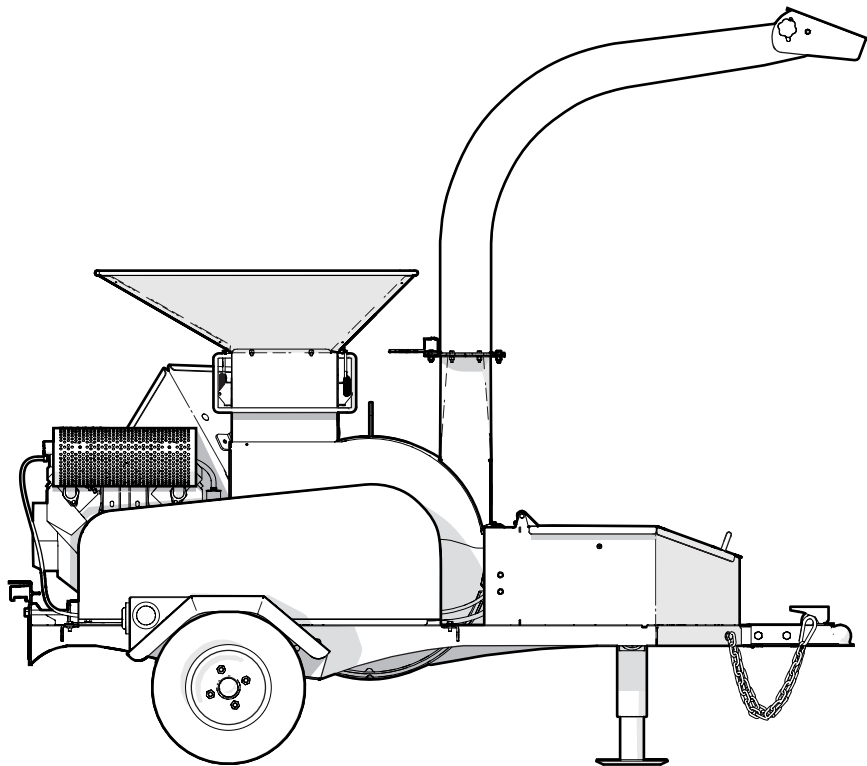

Foreword

This Wallenstein parts manual is prepared to assist customers in ordering quality OEM replacement parts.

Regular maintenance combined with replacing old, worn or broken parts with the correct OEM parts is essential in prolonging the life of your Wallenstein product. Refer to this manual to identify replacement parts.

To order parts, contact your Wallenstein dealer or distributor. Have the product model and serial number handy.

If your dealer is no longer available, please go to our website: <http://wallensteinequipment.com> and click on the [Dealer Locator](#) to find the nearest dealer.

All information contained in this parts manual is current as per the revision date at the bottom of the page. Wallenstein reserves the right to change product specifications at any time without notice.

If your product specifications differ from those contained in this manual, contact Wallenstein for current information.

Reproduction of information in this parts manual is prohibited without prior written permission from Wallenstein Equipment Inc.

Wallenstein Equipment Inc. • © 2020

WARNING!

Refer to the operators manual for safe operation and maintenance.

Maintenance should be performed by trained personnel only.

Serial Number Location

Always provide the model and serial number of your Wallenstein product when ordering parts or requesting service or other information. This information is found on the product information plate as shown below.

Record your product information here for future reference.

Model _____

Serial Number _____

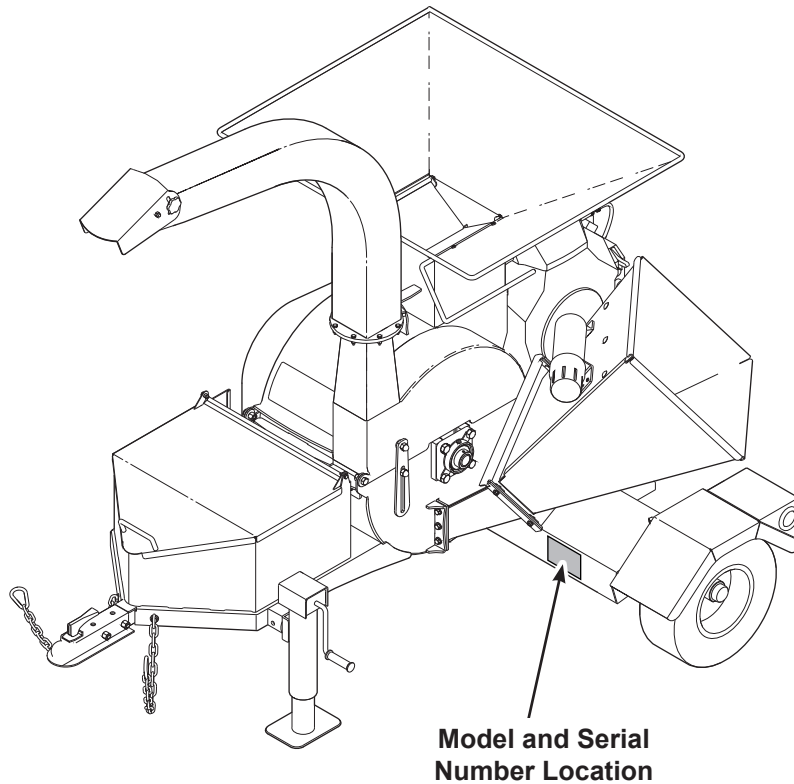

www.wallensteinequipment.com

Contents

Main Frame	4
Blower Parts	5
Lower Rotor Housing	6
Running Gear NEED S/N 2E9US1117FS040138 to 2E9US111XLS050124.....	7A
Running Gear NEED S/N 2E9US111XLS050125 and Up	7B
Idler Hub Assembly.....	8
Chipper Feed Hopper Flap.....	9
Discharge Chute Assembly.....	10
Rotor	11
Fuel Tank Assembly and Lines	12
Decal Layout.....	13
Common Bolt Torque Values	15
Wheel Lug Torque Values.....	16

Main Frame

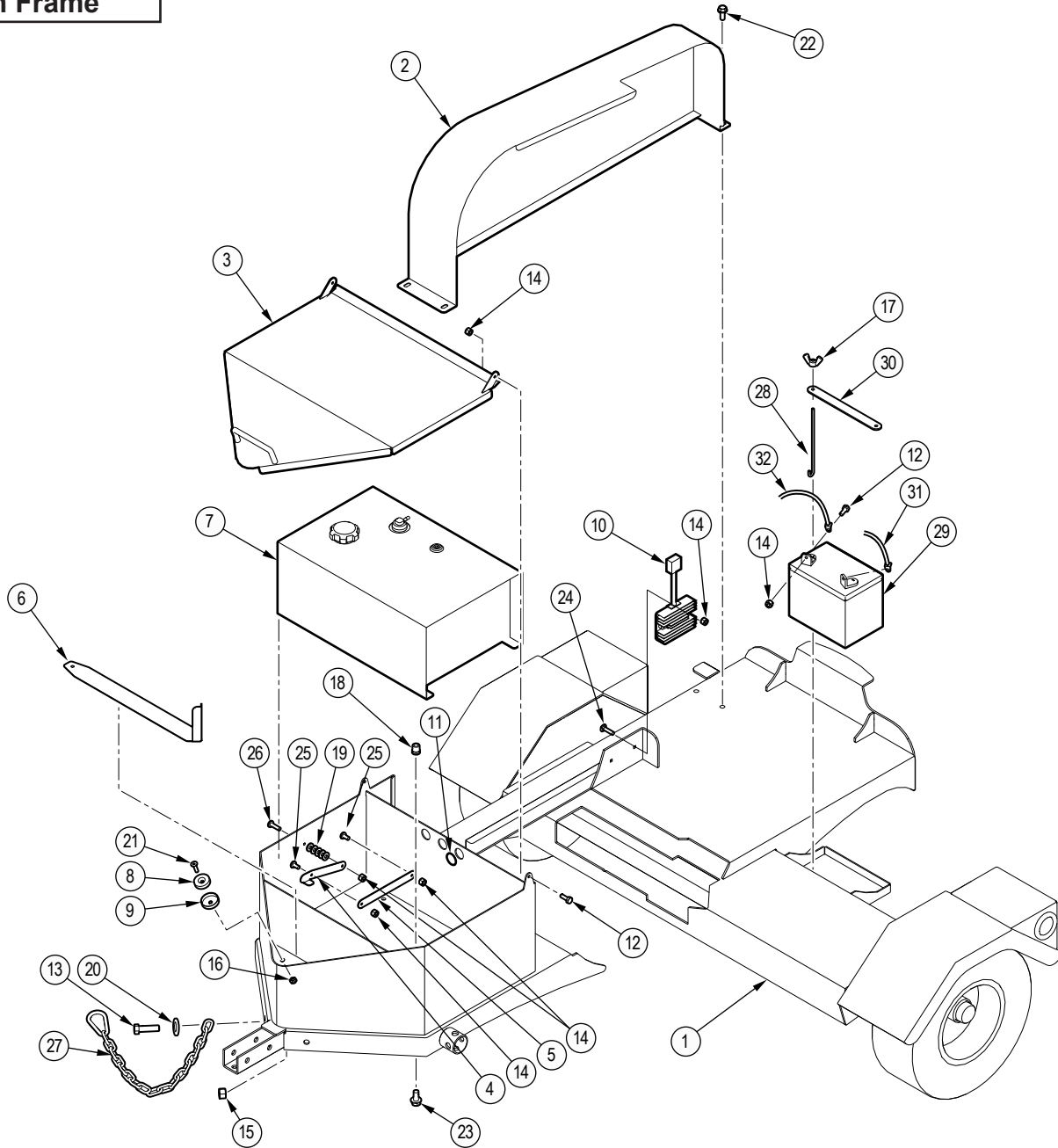

Item No.	Part No.	Description	Qty
1	1055W503	Main Frame	1
2	1055W510	Belt Shield	1
3	1055W519	Tool Box Lid	1
4	1055L594	Lock Link, Toolbox Lid	1
5	1055L595	Link, Toolbox Lid	1
6	1012L269	Gauge, Ledger Setting	1
7	1052A501	Fuel Tank, Trailer Chippers EPA	1
8	Z19910	Puck Magnet, 1"	1
9	Z19911	Magnet Cup, 1" for Z19910	1
10	Z47901	Regulator Rectifier	1
11	Z62823	Rubber Grommet, 5/8" x 1/8"	2
12	Z71107	Hex Bolt, 1/4NC x 3/4"	4
13	Z71415	Hex Bolt, 7/16NC x 1-1/2"	2
14	Z72211	Hex Lock Nut, 1/4NC	9
15	Z72241	Hex Lock Nut, 7/16NC	2
16	Z72752	Machine Nut, #10NF	1

Item No.	Part No.	Description	Qty
17	Z72921	Wing Nut, 1/4NC	2
18	Z72958	Rivet Nut, 3/8NC x 150	4
19	Z73111	SAE Washer, 1/4"	5
20	Z73142	SAE Washer, 7/16"	2
21	Z75203	FHCS, #10NF x 3/4"	1
22	Z76121	Flange Bolt, 5/16NC x 3/4"	4
23	Z76133	Flange Bolt, 3/8NC x 3/4"	4
24	Z76212	Carriage Bolt, 1/4NC x 1"	2
25	Z78317	Machine Screw, 1/4NC x 1/2"	2
26	Z78318	Machine Screw, 1/4NC x 7/8"	1
27	Z92303	Safety Chain, 1/4" x 2ft with Snap	2
28	Z93202	J-Hook, 1/4" x 7"	2
29	Z93204	Battery, 325CCA	1
30	Z93207	Hold-Down Strap, 1" x 8-1/2"	1
31	Z93213	Battery Cable, Negative x 36"	1
32	Z93214	Battery Cable, Positive x 36"	1

Blower Parts

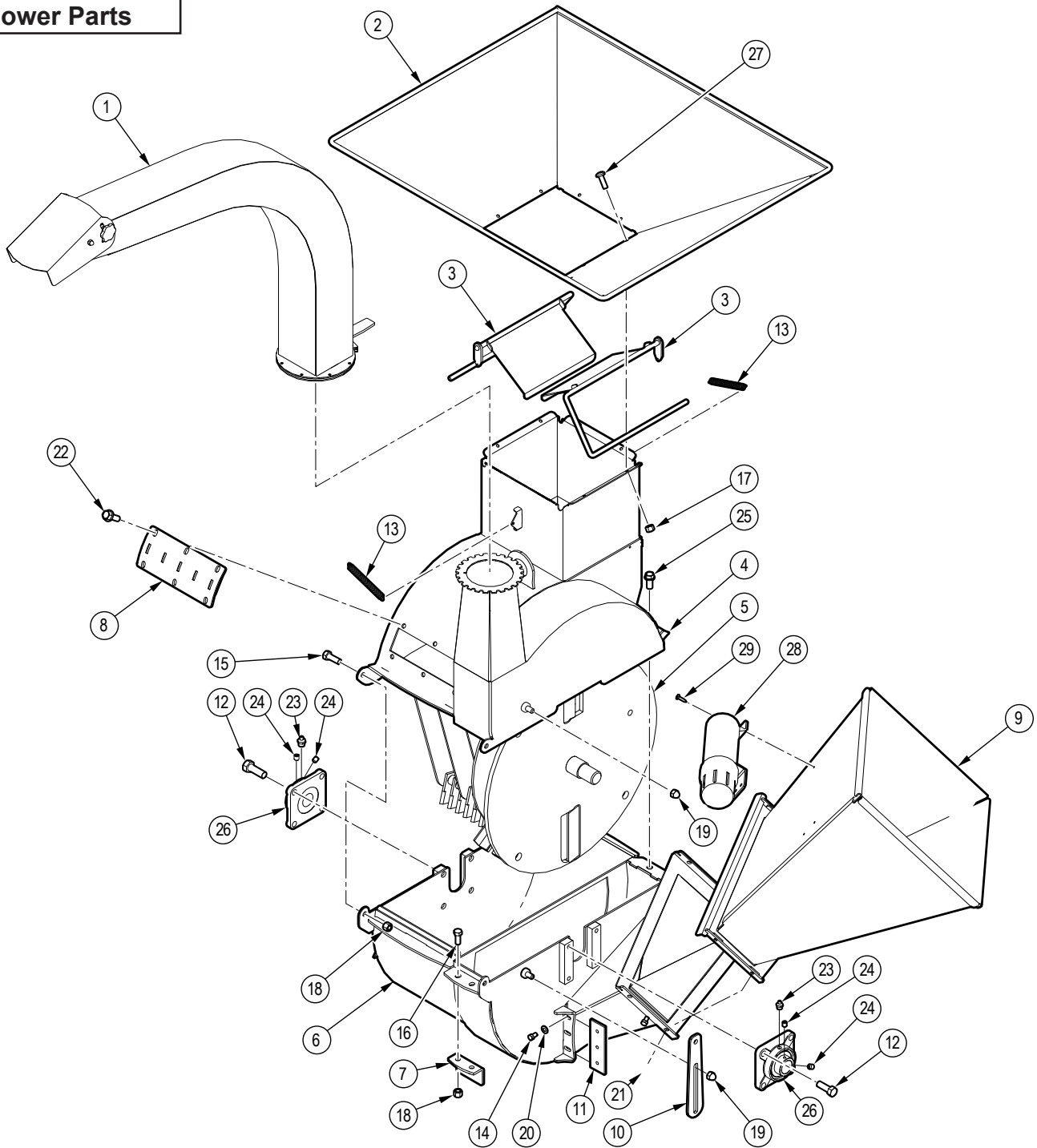

Item No.	Part No.	Description	Qty
1	1055A502	Assembly, Discharge Chute	1
2	1016W627	Hopper, Shredder	1
3	1016W625	Flapper	2
4	1055W517	Housing, Upper Rotor	1
5	1016W603	Rotor	1
6	1055W518	Housing, Bottom Rotor	1
7	1011W104	Twig Breaker	1
8	1016W634	Chop Block	1
9	1016W632	Chipper Feed Hopper	1
10	1055L598	Positive Stop Plate	1
11	1011M104	Knife, 4" Ledger	1
12	Z71672G8	Hex Bolt, 5/8NF x 1-3/4" G8	8
13	Z31301	Ext Spring, 17mm OD x 140mm x 0.080"	2
14	Z71372G8	Hex Bolt, 3/8NF x 5/8" G8	3
15	Z71510	Hex Bolt, 1/2NC x 1"	2

Item No.	Part No.	Description	Qty
16	Z71512	Hex Bolt, 1/2NC x 1-1/4"	2
17	Z72211	Hex Lock Nut, 1/4NC	8
18	Z72251	Hex Lock Nut, 1/2NC	4
19	Z72915	Acorn Nut, 1/2NC	2
20	Z73131	SAE Washer, 3/8"	3
21	Z76121	Flange Bolt, 5/16NF x 3/4"	4
22	Z76134	Flange Bolt, 3/8NC x 1"	6
23	Z29201	Grease Fitting, MP02	2
24	Z74122	Set Screw, 5/16NF x 3/8"	4
25	Z76153	Flange Bolt, 1/2NC x 1"	1
26	Z25204	4-Bolt Flange Bearing, UCF208-24	2
27	Z78301	Machine Screw, 1/4NC x 3/4"	8
28	Z96503	Manual Tube, 3-1/2" Short	1
29	Z76712	Self-tapping Screw, #10 x 3/4"	3

Lower Rotor Housing

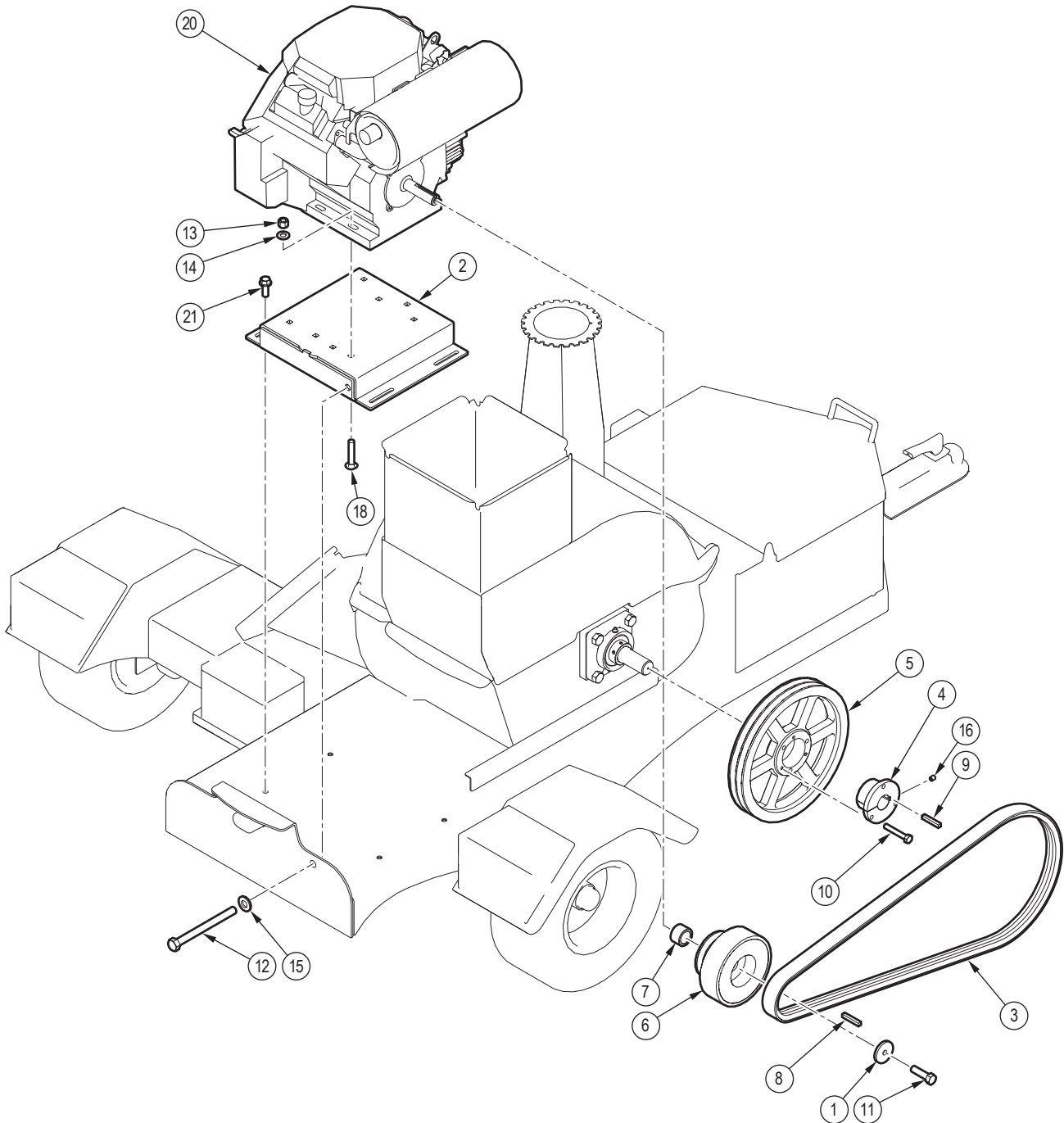

Item No.	Part No.	Description	Qty	Item No.	Part No.	Description	Qty
1	1052L503	Washer, Clutch Trap x 7/16"	1	11	Z71472	Hex Bolt, 7/16NF x 1-1/2"	1
2	1055W514	Engine Mount	1	12	Z71590	Hex Bolt, 1/2NC x 5-1/2" Full Threads	1
3	Z41259	Belt, Double "B" x 77"	1	13	Z72231	Hex Lock Nut, 3/8NC	4
4	Z41501	Hub, SK x 1-3/8"	1	14	Z73131	SAE Washer, 3/8"	4
5	Z41702	Double Sheave, 2B124 x SK	1	15	Z73151	SAE Washer, 1/2"	1
6	Z41902	Centrifugal Clutch, 2B39 x 1-1/8"	1	16	Z74111	Set Screw, 1/4NC x 1/4"	1
7	Z46353	Spacer, 1-1/8" ID x 1.065"	1	18	Z76235	Carriage Bolt, 3/8NC x 2"	4
8	Z46532	Key, 1/4" x 1/4" x 1-1/2"	1	19	Z93314	Plastic Reducer, HB x HB 0403	1
9	Z46543	Key, 5/16" x 5/16" x 1-1/2"	1	20	Z47168	Honda GX690RTXF, Rope - BXMT4224	1
10	Z71220	Hex Bolt, 5/16NC x 2"	3	21	Z76134	Flange Bolt, 3/8NC x 1"	4

Running Gear S/N 2E9US1117FS040138 to 2E9US111XLS050124

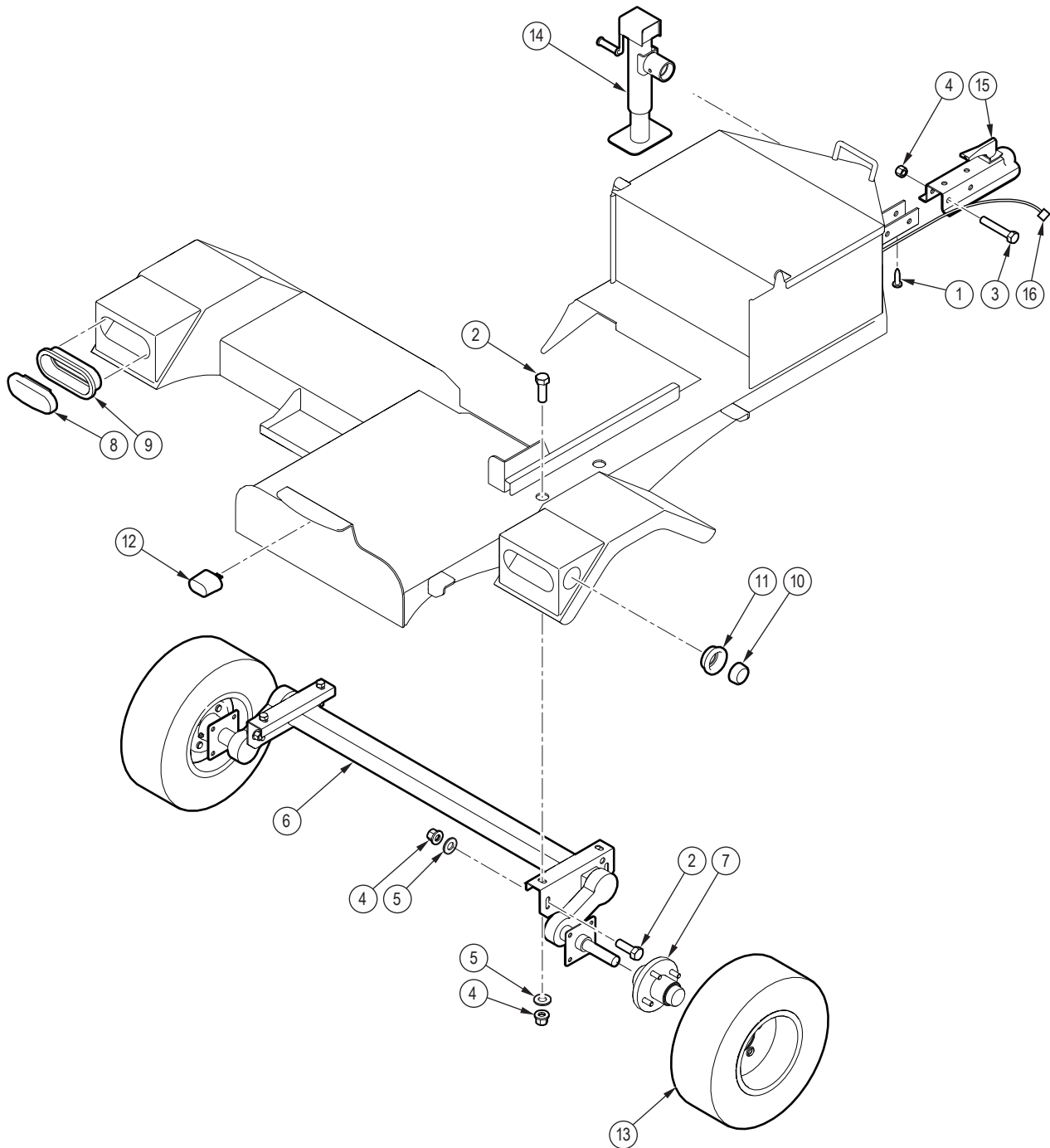

Item No.	Part No.	Description	Qty	Item No.	Part No.	Description	Qty
1	Z76712	Self-tapping Screw, #10 x 3/4"	5	9	Z61103	Grommet, Oval x Open Back	2
2	Z71515	Hex Bolt, 1/2NC x 1-1/2"	8	10	Z61201	Marker Lamp, Round x Red	2
3	Z71530	Hex Bolt, 1/2NC x 3"	2	11	Z61202	Grommet, Round x Open Back	2
4	Z72251	Hex Lock Nut, 1/2NC	10	12	Z61301	License Lamp, White	1
5	Z73151	SAE Washer, 1/2"	8	13	Z91316	16.5x6.5-8 LRC USA Trail 4on4"	2
6	Z91115-1	#9 Full Flex Axle, 2200lbs x 54" HF Axle Only	1	14	Z91512	Trailer Jack, Side Wind x 2000lbs	1
7	Z91206	Idle Hub Assy, 1000lbs x 4on4" x 1-1/16"	2	15	Z91614	Hitch Coupler, 2" Ball x 2" x 3500lbs	1
8	Z61102	STT Lamp, Oval	2	16	Z62101	Harness, 300 Lights	1

Running Gear S/N 2E9US111XLS050125 and Up

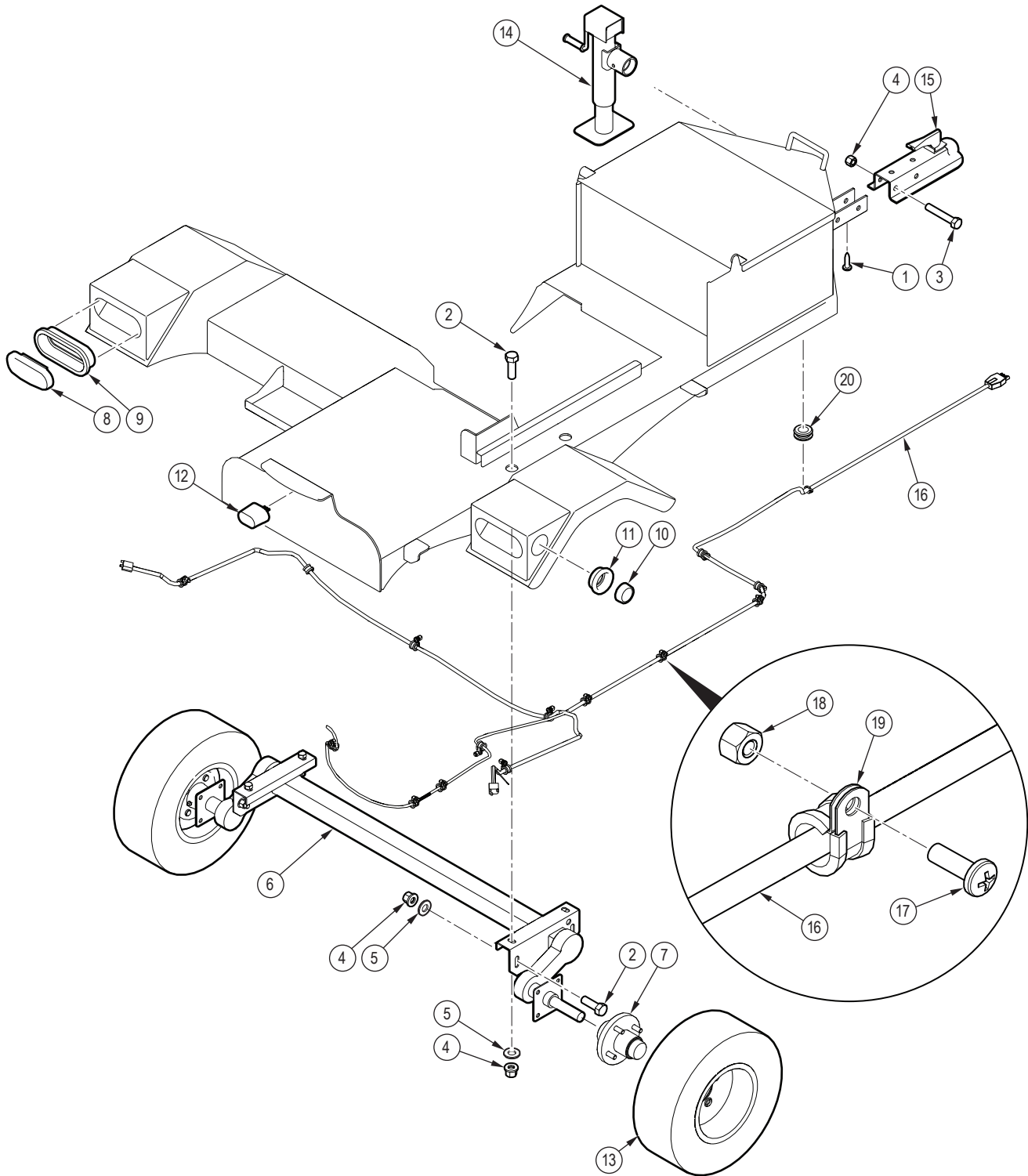

Item No.	Part No.	Description	Qty
1	Z76712	Self-tapping Screw, #10 x 3/4"	5
2	Z71515	Hex Bolt, 1/2NC x 1-1/2"	8
3	Z71530	Hex Bolt, 1/2NC x 3"	2
4	Z72251	Hex Lock Nut, 1/2NC	10
5	Z73151	SAE Washer, 1/2"	8
6	Z91115-1	#9 Full Flex Axle, 2200lbs x 54" HF Axle Only	1
7	Z91206	Idler Hub Assy, 1000lbs x 4on4" x 1-1/16"	2
8	Z61102	STT Lamp, Oval	2
9	Z61103	Grommet, Oval x Open Back	2
10	Z61201	STT Lamp, Oval	2

Item No.	Part No.	Description	Qty
11	Z61202	Grommet, Round x Open Back	2
12	Z61301	License Lamp, White	1
13	Z91316	16.5x6.5-8 LRC USA Trail 4on4"	2
14	Z91512	Trailer Jack, Side Wind x 2000lbs	1
15	Z91614	Hitch Coupler, 2" Ball x 2" x 3500lbs	1
16	1055F001	BXMT42, Wiring Harness	1
17	Z78301	Machine Screw, 1/4NC x 3/4"	14
18	Z72211	Hex Lock Nut, 1/4NC	15
19	Z62819	Rubberized Wire Clamp, 1/2"	15
20	Z62822	Rubber Grommet, 3/4" x 1/4"	1

Idler Hub Assembly

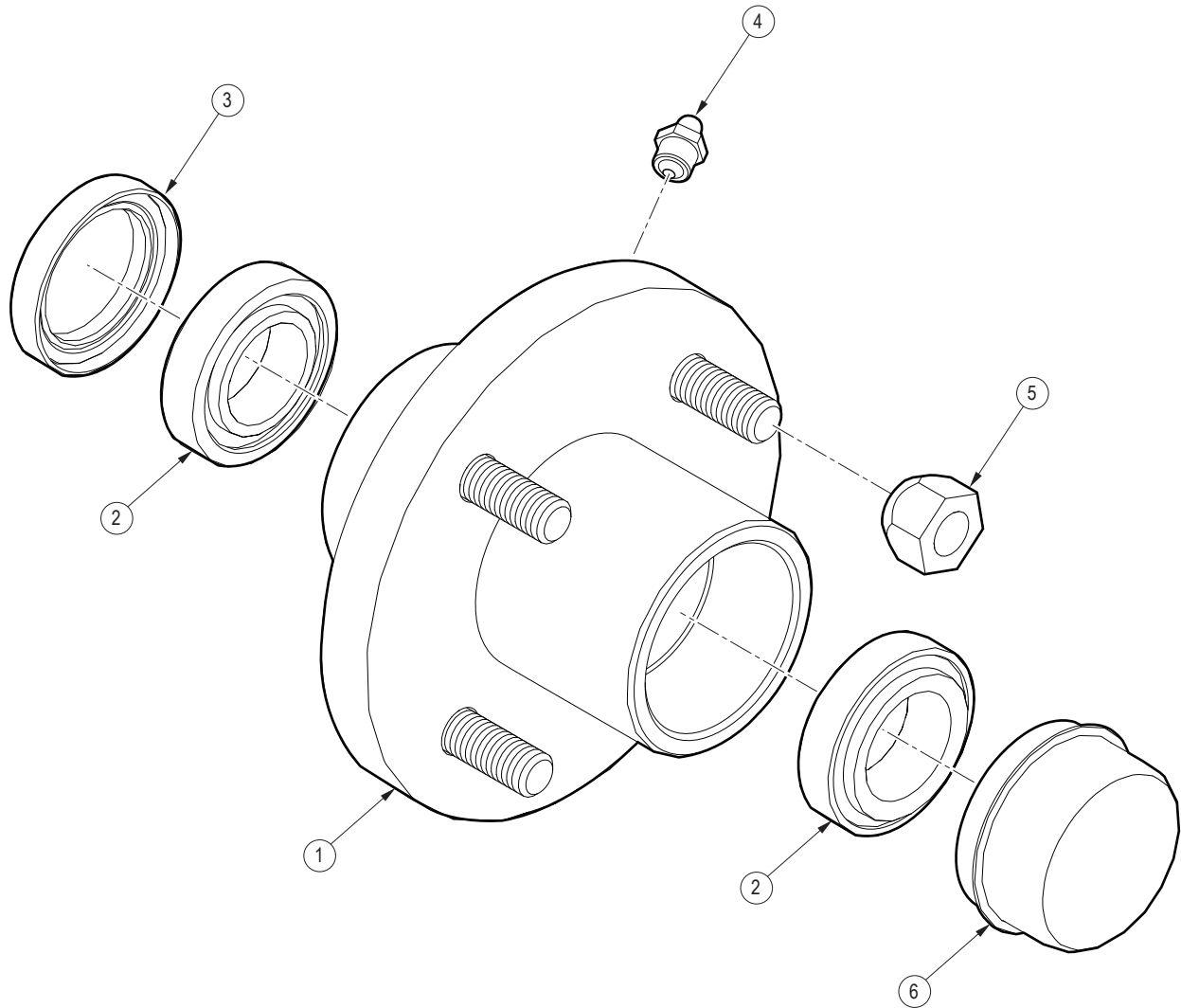

Item No.	Part No.	Description	Qty
1	Z91201	Hub, 1000lbs x 4on4	1
2	Z23202	Roller Bearing, L44649 L44610	2
3	Z28302	Double Lip Seal, 1-1/16"	1
4	Z29201	Grease Fitting, MP02	1
5	Z72931	Lug Nut, 1/2NF	4
6	Z91801	Dust Cap, 1.98 Bore	1

Chipper Feed Hopper Flap

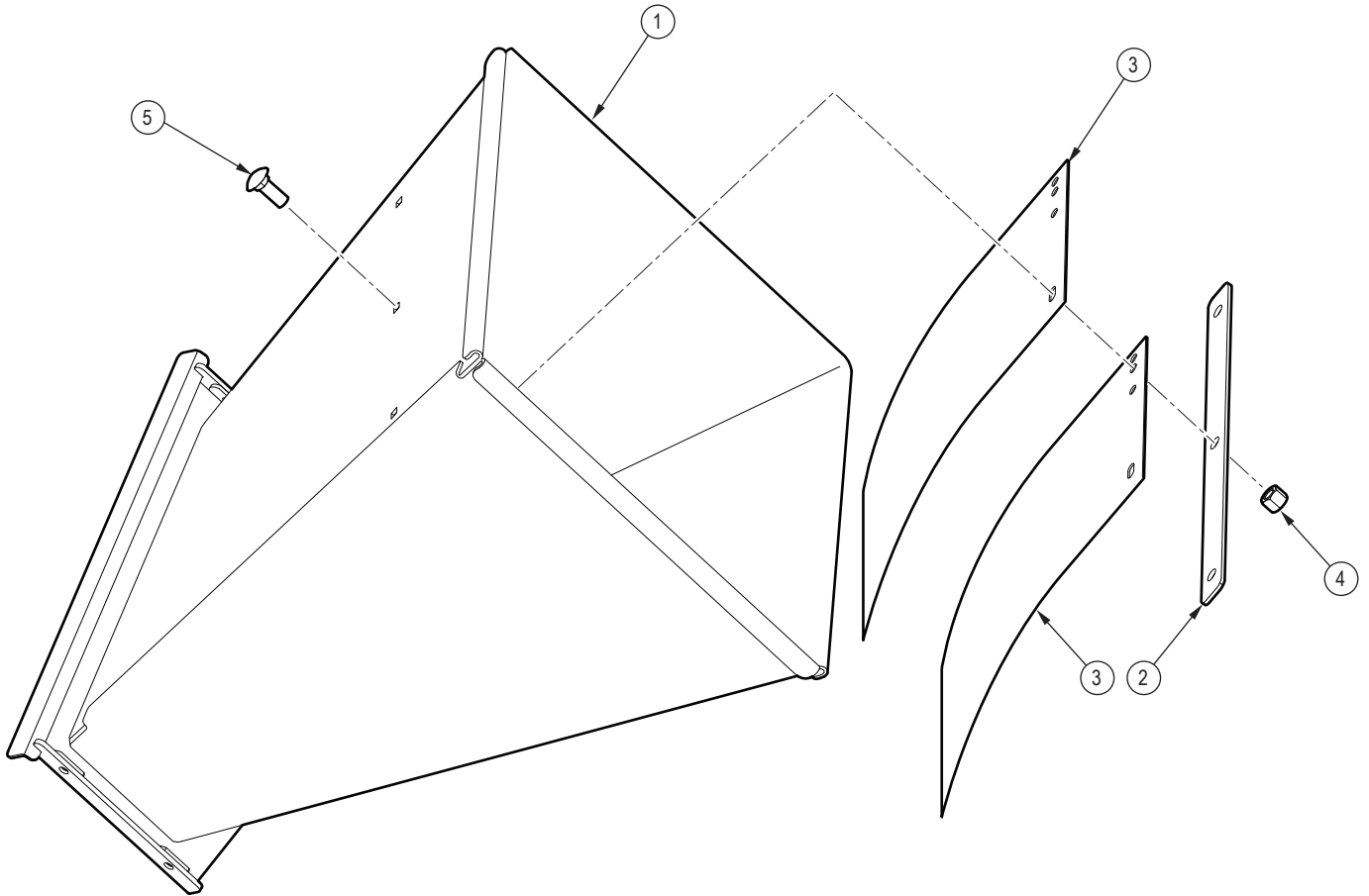

Item No.	Part No.	Description	Qty
1	1016W632	Chipper Feed Hopper	1
2	1011L151	Strap, Hopper Flap	1
3	1011S103	Flap, Hopper	2
4	Z72231	Hex Lock Nut, 3/8NC	3
5	Z76231	Carriage Bolt, 3/8NC x 1"	3

Discharge Chute Assembly

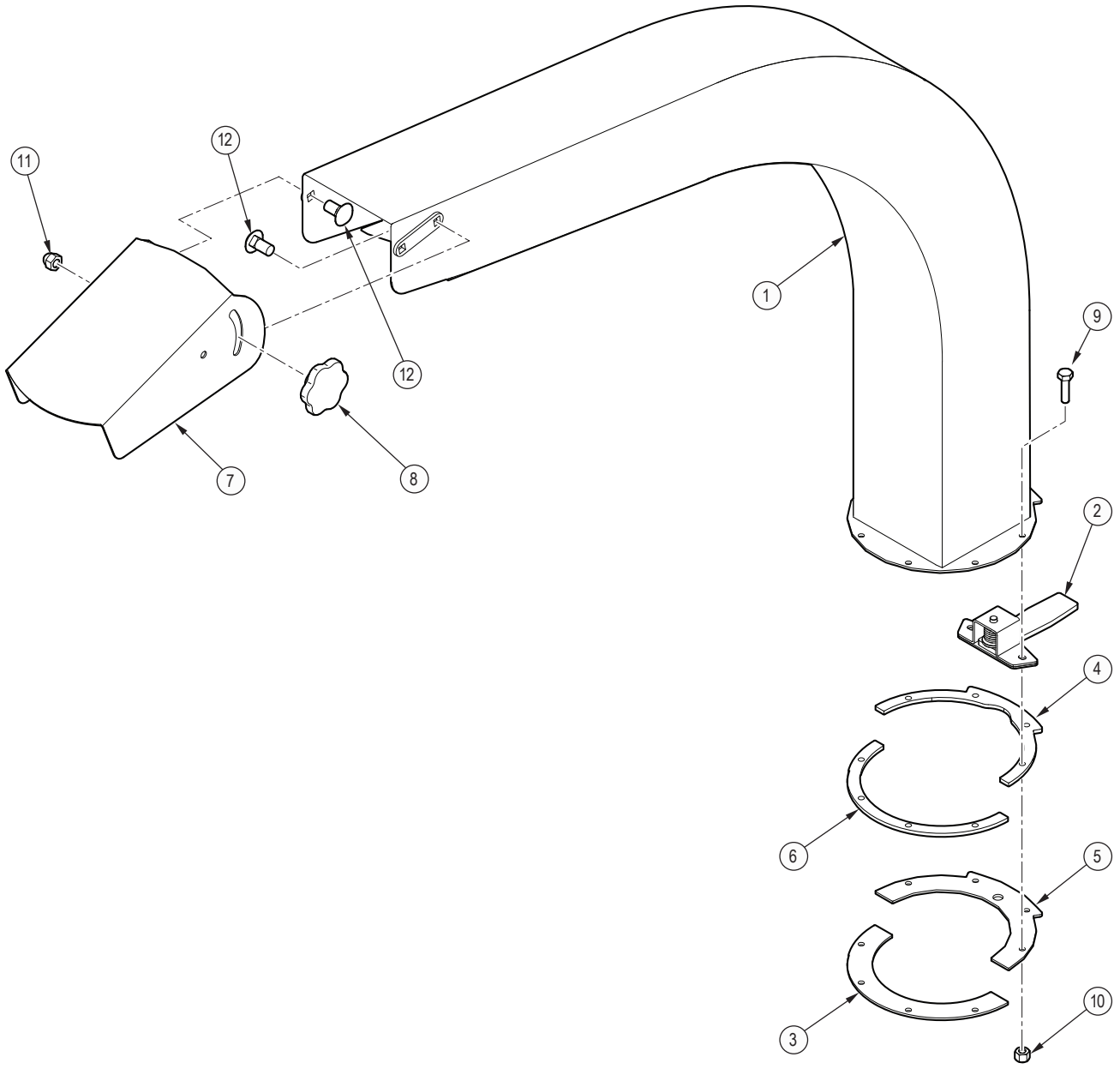

Item No.	Part No.	Description	Qty	Item No.	Part No.	Description	Qty
1	1055W507	Discharge Chute	1	7	1055L533	Deflector, Discharge Chute	1
2	1012W208	Assembly, Hood Latch	1	8	Z19313	Hand Knob, 5/16NC Female Stud	2
3	1016L027	Plate, Spacer Ring	1	9	Z71110	Hex Bolt, 1/4NC x 1"	8
4	1016L029	Plate, Spacer Ring	1	10	Z72211	Hex Lock Nut, 1/4NC	8
5	1016L030	Plate, Hood Capture	1	11	Z72914	Acorn Nut, 5/16NC	2
6	1016L034	Plate, Hood Capture	1	12	Z76221	Carriage Bolt, 5/16NC x 3/4"	4

Rotor

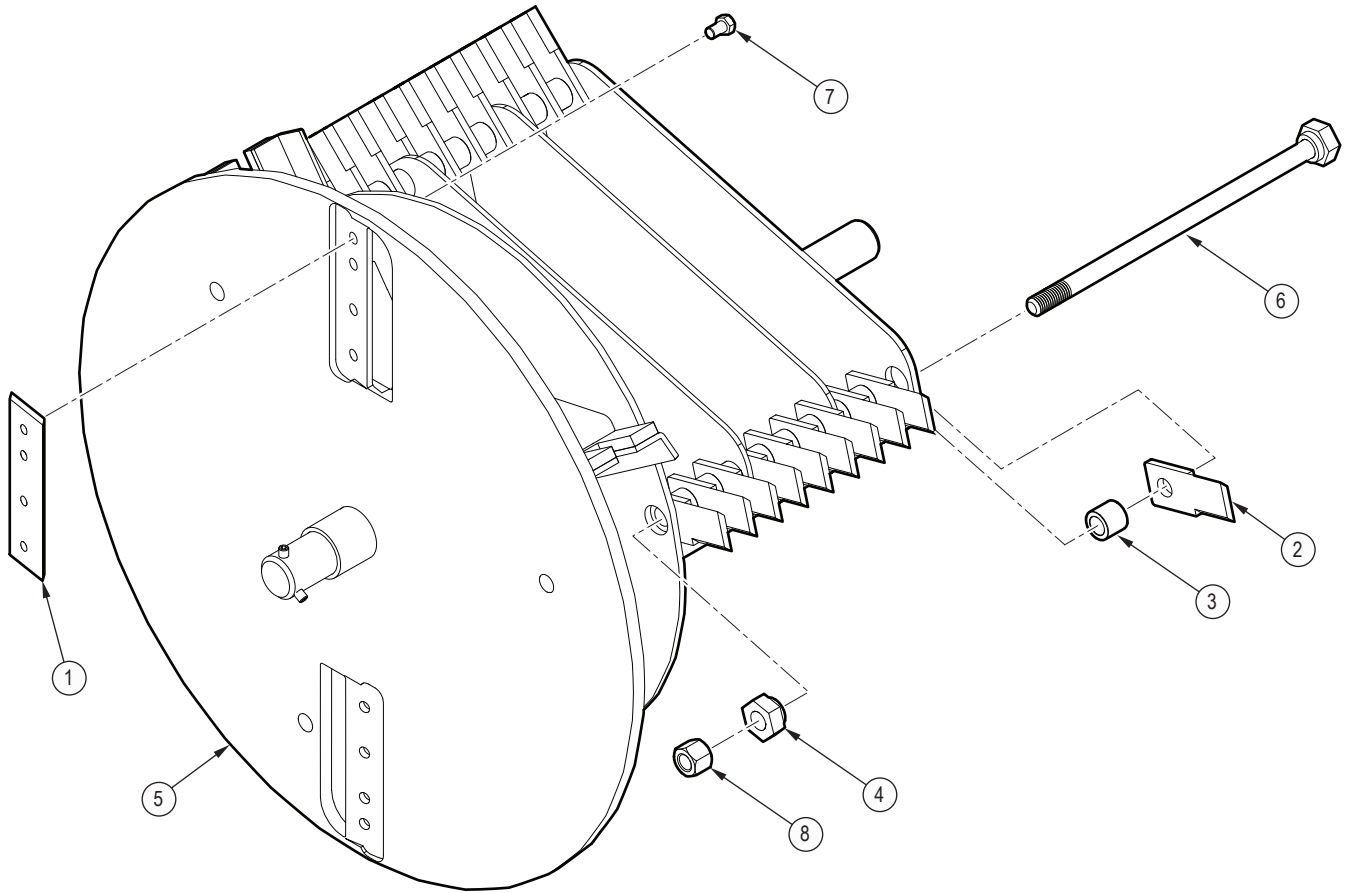

Item No.	Part No.	Description	Qty
1	1011M103	Knife, 4" Rotor	2
2	1016M608	Knife, BXM Shredder	30
3	1016M613	Spacer, Shredder	27
4	1016M627	Bushing, Retainer Rod	3
5	1016W603	Rotor	1
6	1016W626	Retainer Pin	3
7	Z71372G8	Hex Bolt, 3/8NF x 5/8" G8	8
8	Z72261	Hex Lock Nut, 5/8NC	3

Fuel Tank Assembly and Lines

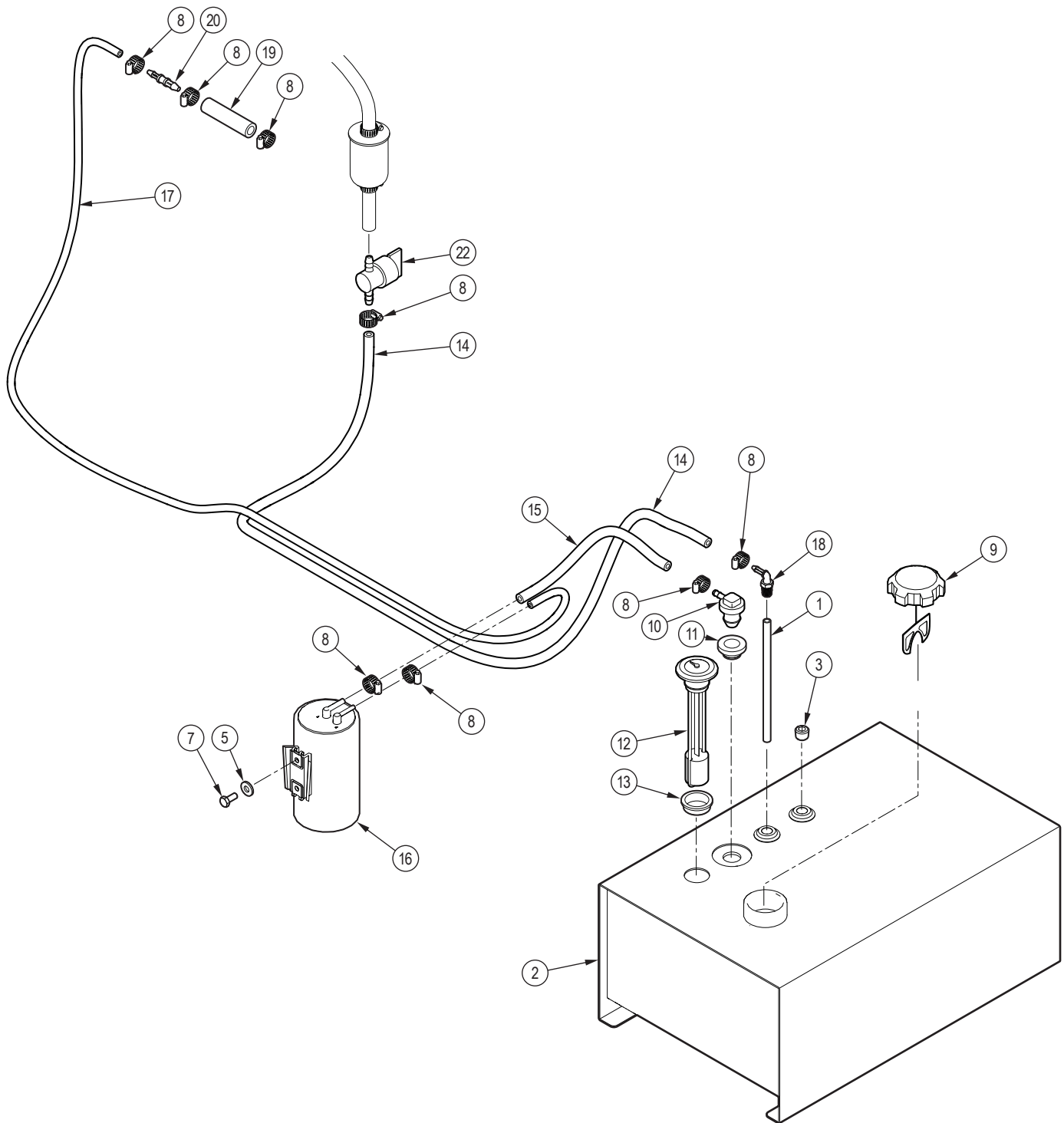

Item No.	Part No.	Description	Qty
1	1052S501	Fuel Pickup Tube	1
2	1052W501	Fuel Tank, Trailer Chipper	1
3	Z51194	Socket Plug, MP 04	1
5	Z73111	SAE Washer, 1/4"	2
7	Z77130	Hex Bolt, M6x1.0 x 14mm	2
8	Z79405	Hose Clamp, SAE #4 (5/8") BXT6224	11
9	Z93108	EPA Ratchet Fuel Cap, Unleaded Fuel x Unvented with Tether	1
10	Z93110	EPA Remote Vent, HB04	1
11	Z93111	Vent Grommet For Z93110	1
12	Z93113	Fuel Gauge, Grommet Mount x 7"	1

Item No.	Part No.	Description	Qty
13	Z93115	Fuel Gauge Grommet for Z93113	1
14	Z93307	EPA Fuel Line, 1/4" x 55" BXT6228su	1
15	Z93307	EPA Fuel Line, 1/4" x 8"	1
16	Z93309	EPA Carbon Canister, 652cc	1
17	Z93310	EPA Fuel Line, 3/16" x 68" BXT6224 A	1
18	Z93312	Plastic Elbow 90, MP x HB 0404 BXT6224 A	1
19	Z93313	Fuel Line, 3/8" ID x 3" BXT6224 Only	1
20	Z93314	Plastic Reducer, HB x HB 0403 BXT6224 Only	1
22	Z93301	Fuel Shut-Off Valve, 1/4" BXT6228su Only	1
23	Z93307	EPA Fuel Line, 1/4" ID x 4" BXT6228su Only	1

Decal Layout

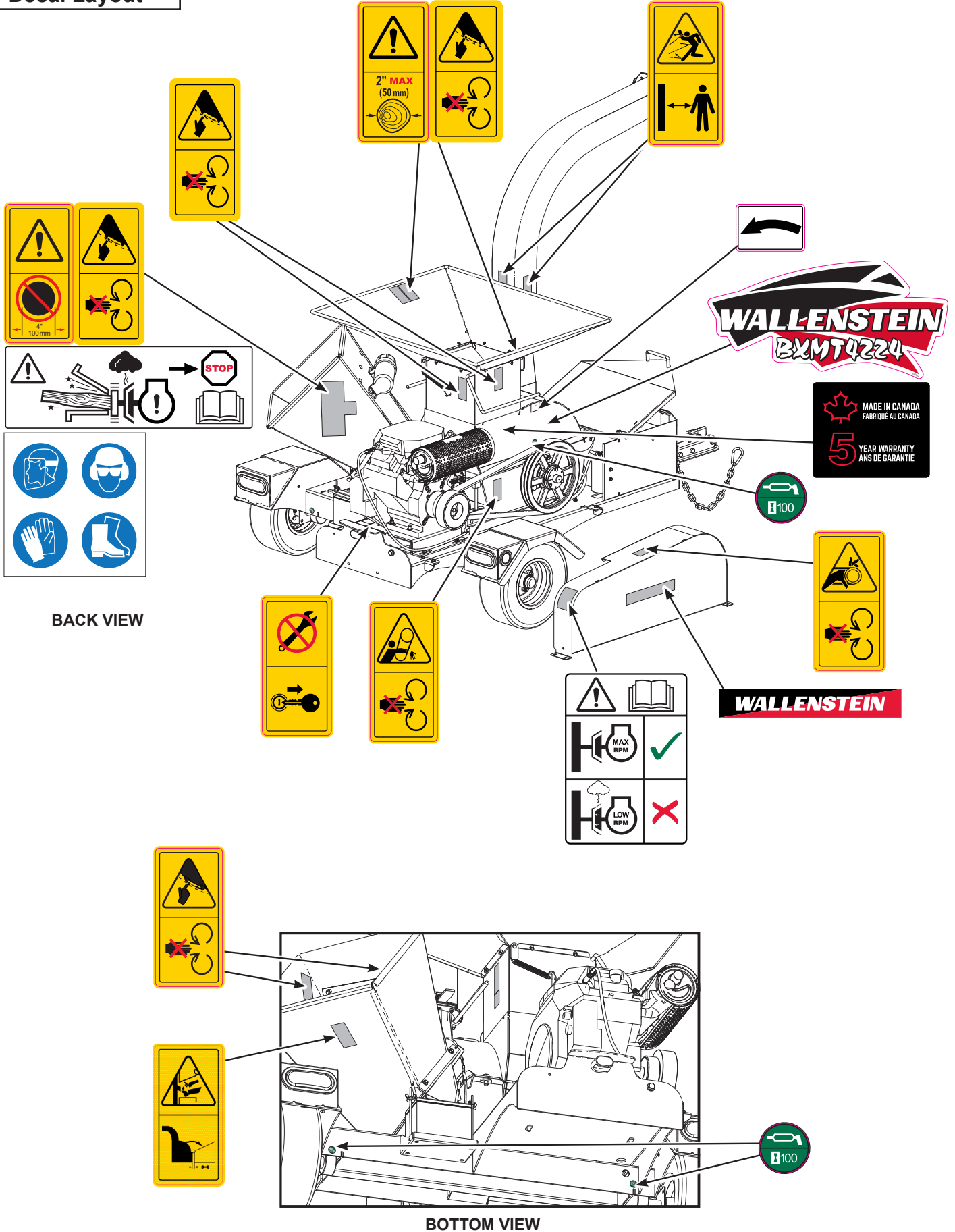

BACK VIEW

BOTTOM VIEW

Common Bolt Torque Values

Checking Bolt Torque

The tables shown give correct torque values for various bolts and capscrews. Tighten all bolts to the torque values specified in the table, unless indicated otherwise. Check tightness of bolts periodically.

IMPORTANT! If replacing hardware, use fasteners of the same grade.

IMPORTANT! Torque figures indicated in the table are for non-greased or non-oiled threads. Do not grease or oil threads unless indicated otherwise. When using a thread locker, increase torque values by 5%.

 **NOTE:** Bolt grades are identified by their head markings.

Imperial Bolt Torque Specifications

Bolt Diameter	Torque Value					
	SAE Gr. 2		SAE Gr. 5		SAE Gr. 8	
	lbf•ft	N•m	lbf•ft	N•m	lbf•ft	N•m
1/4"	6	8	9	12	12	17
5/16"	10	13	19	25	27	36
3/8"	20	27	33	45	45	63
7/16"	30	41	53	72	75	100
1/2"	45	61	80	110	115	155
9/16"	60	95	115	155	165	220
5/8"	95	128	160	215	220	305
3/4"	165	225	290	390	400	540
7/8"	170	230	420	570	650	880
1"	225	345	630	850	970	1320



SAE Gr. 2



SAE Gr. 5



SAE Gr. 8

Metric Bolt Torque Specifications

Bolt Diameter	Torque Value			
	Gr. 8.8		Gr. 10.9	
	lbf•ft	N•m	lbf•ft	N•m
M3	0.4	0.5	1.3	1.8
M4	2.2	3	3.3	4.5
M6	7	10	11	15
M8	18	25	26	35
M10	37	50	52	70
M12	66	90	92	125
M14	83	112	116	158
M16	166	225	229	310
M20	321	435	450	610
M30	1,103	1 495	1,550	2 100



8.8



10.9

Wheel Lug Torque Values

It is extremely important safety procedure to apply and maintain proper wheel mounting torque on your trailer axle. Torque wrenches are the best method to assure the proper amount of torque is being applied to a fastener.

Wheel lugs should be torqued before first road use and after each wheel removal. Check and re torque after the first 10 miles (16 km), 25 miles (40 km), and again at 50 miles (80 km). Check periodically thereafter.

NOTE: *Wheel lugs must be applied and maintained at the proper torque levels to prevent loose wheels, broken studs, and possible dangerous separation of wheels from your axle.*

- Start all lugs by hand to prevent cross threading.
- Tighten lugs in sequence, per wheel lug torque sequence chart.
- The tightening of the fasteners should be done in stages. Following the recommended sequence, tighten fasteners per wheel torque requirements chart.

Wheel Lug Nut Torque				
Wheel Size	Units	1st Stage	2nd Stage	3rd Stage
8"	lbf•ft N•m	12–20 16–26	30–35 39–45.5	45–55 58.5–71.5
12"	lbf•ft N•m	20–25 26–32.5	35–40 45.5–52	50–60 65–78
13"	lbf•ft N•m	20–25 26–32.5	35–40 45.5–52	50–60 65–78
14"	lbf•ft N•m	20–25 26–32.5	50–60 65–78	90–120 117–156
15"	lbf•ft N•m	20–25 26–32.5	50–60 65–78	90–120 117–156
16"	lbf•ft N•m	20–25 26–32.5	50–60 65–78	90–120 117–156

Wheel Lug Torque Pattern

