

PARTS MANUAL

Serial Number 120554 & up

WX410 **SKID STEER-MOUNTED LOG SPLITTER**

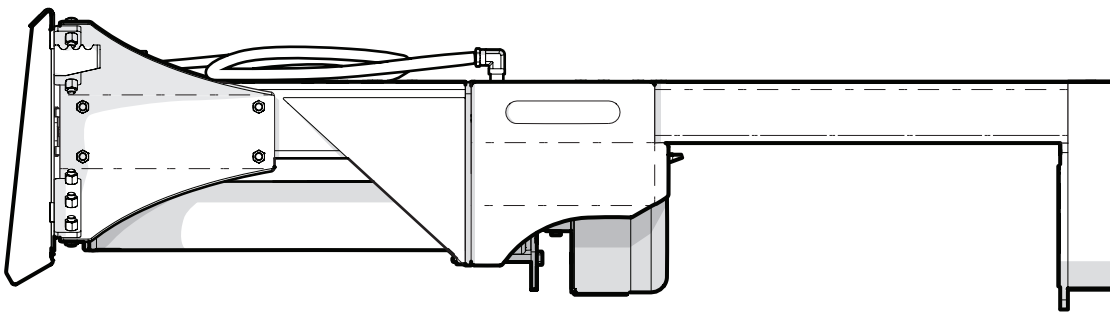

Foreword

This Wallenstein parts manual is prepared to assist customers in ordering quality OEM replacement parts.

Regular maintenance combined with replacing old, worn or broken parts with the correct OEM parts is essential in prolonging the life of your Wallenstein product. Refer to this manual to identify replacement parts.

To order parts, contact your Wallenstein dealer or distributor. Have the product model and serial number handy.

If your dealer is no longer available, please go to our website: <http://wallensteinequipment.com> and click on the [Dealer Locator](#) to find the nearest dealer.

All information contained in this parts manual is current as per the revision date at the bottom of the page. Wallenstein reserves the right to change product specifications at any time without notice.

If your product specifications differ from those contained in this manual, contact Wallenstein for current information.

Reproduction of information in this parts manual is prohibited without prior written permission from Wallenstein Equipment Inc.

Wallenstein Equipment Inc. • © 2020

WARNING!

Refer to the operators manual for safe operation and maintenance.

Maintenance should be performed by trained personnel only.

Serial Number Location

Always provide the model and serial number of your Wallenstein product when ordering parts or requesting service or other information. This information is found on the product information plate as shown below.

Record your product information here for future reference.

Model _____

Serial Number _____

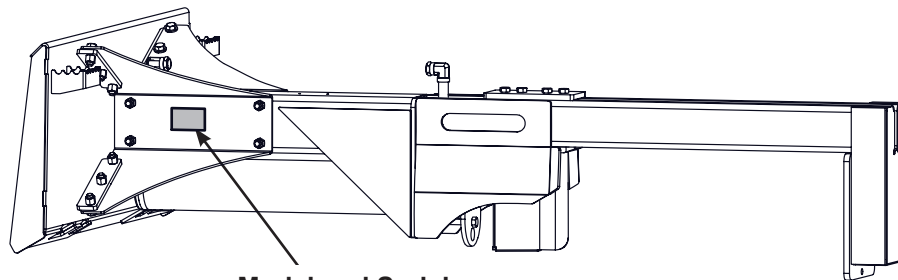

**Model and Serial
Number Location**

www.wallensteinequipment.com

Contents

Main Parts S/N 120554 to 120905	4
Main Parts S/N 120906 and Up.....	5
Hydraulic Cylinder Detail	6
Hydraulic Circuit S/N 120554 to 120905	7
Hydraulic Circuit S/N 120906 and Up	8
Decal Layout.....	9
Accessories	10
Common Bolt Torque Values	11
Hydraulic Fitting Torque Values	12

Main Parts S/N 120554 to 120905

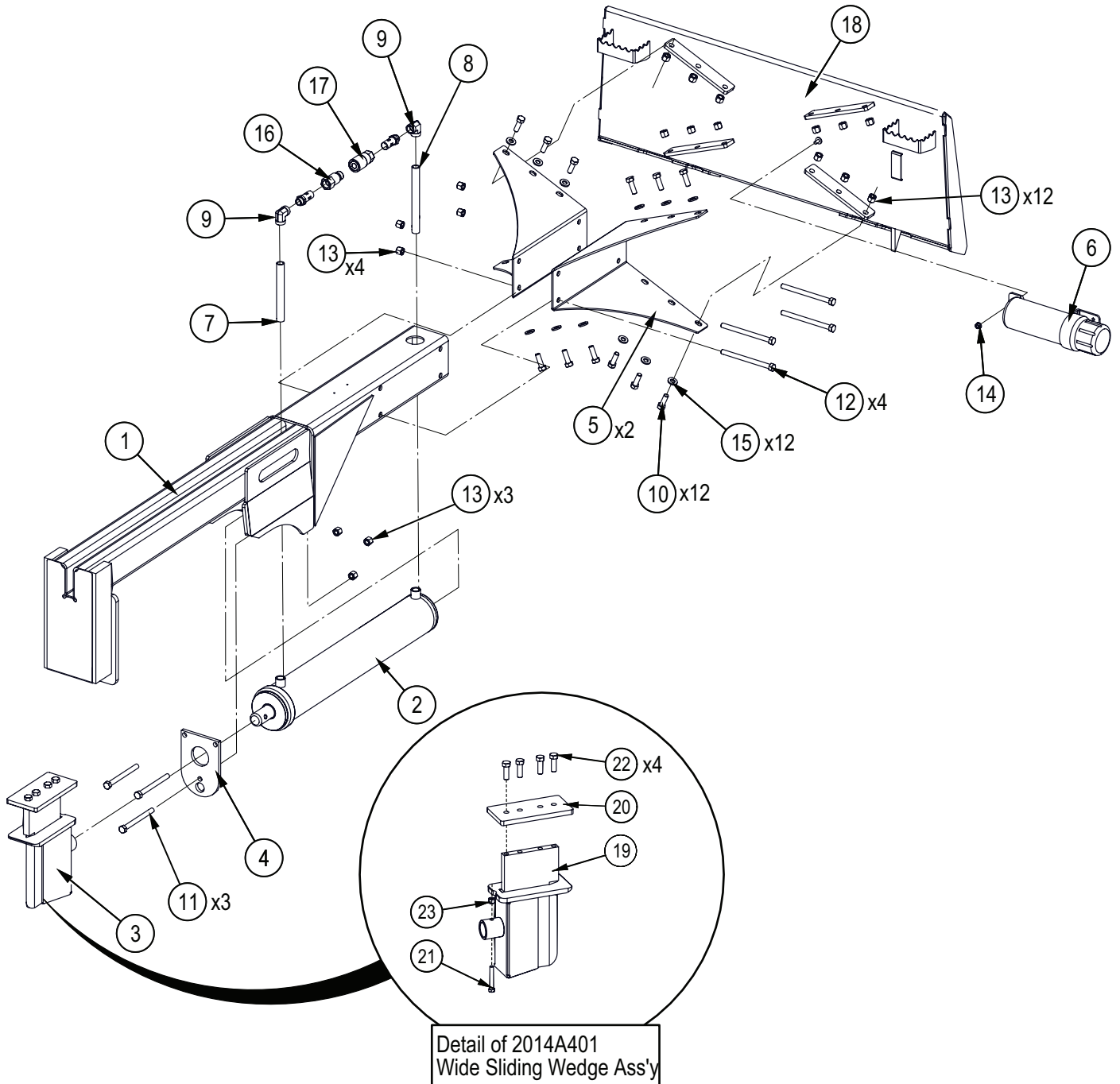

Detail of 2014A401
Wide Sliding Wedge Ass'y

Item No.	Part No.	Description	Qty
1	2031W101	WX410 Main Frame	1
2	2011C101	Cylinder, 4 x 24 x 1-1/2	1
3	2014A401	Assembly, Wide Sliding Wedge	1
4	2014S421	Plate, Cylinder Retaining (Bolt)	1
5	2031L101	Gusset Frame, Skidsteer Mount	2
6	Z96503	Manual Tube, 3-1/2" Short	1
7	Z51111	Pipe Nipple, MP08 x 7"	1
8	Z51112	Pipe Nipple, MP08 x 8"	1
9	Z51243	Elbow 90, FP x FP 0808	2
10	Z71515	Hex Bolt, 1/2NC x 1-1/2"	12
11	Z71555	Hex Bolt, 1/2NC x 5-1/2"	3
12	Z71565	Hex Bolt, 1/2NC x 6-1/2"	4

Item No.	Part No.	Description	Qty
13	Z72251	Hex Lock Nut, 1/2NC	19
14	Z72521	Serrated Flange Locknut, 5/16NC	1
15	Z73151	SAE Washer, 1/2"	12
16	Z51919	Flat-Face Coupler, FP08 x M ISO 16028	1
17	Z51920	Flat-Face Coupler, FP08 x F ISO 16028	1
18	2031W103	Weldment, Skidsteer Mount	1
19	2014W402	Weldment, Sliding Wedge	1
20	2014S414	Plate, Sliding Wedge Capture	1
21	Z71325	Hex Bolt, 3/8NC x 2-1/2"	1
22	Z71576G8	Hex Bolt, 1/2NF x 1-1/2" G8	4
23	Z72231	Hex Lock Nut, 3/8NC	1

Main Parts S/N 120906 and Up

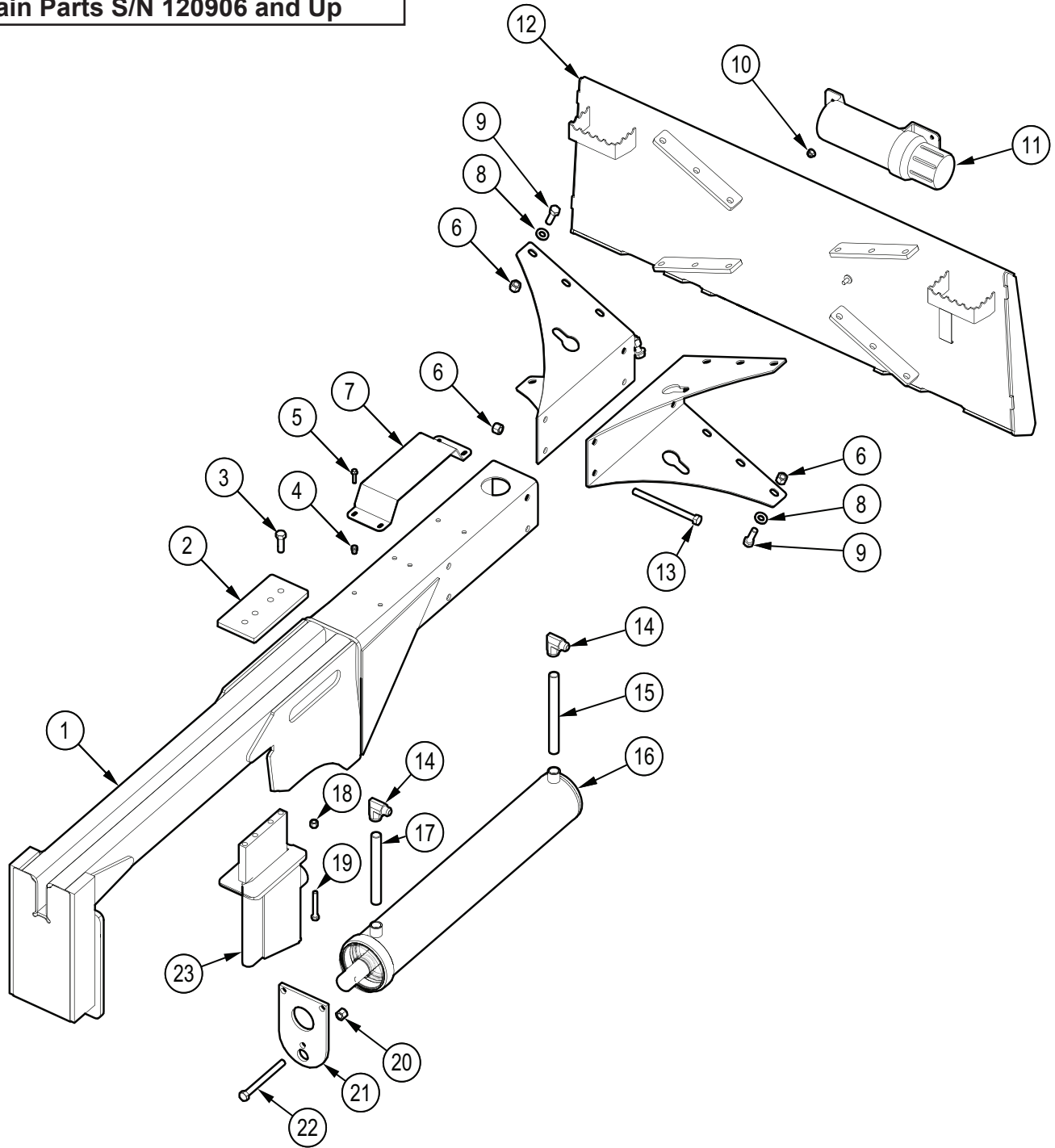

Item No.	Part No.	Description	Qty
1	2031W101	WX410 Main Frame	1
2	2014S414	Plate, Sliding Wedge Capture	1
3	Z71576G8	Hex Bolt, 1/2NF x 1-1/2" G8	4
4	Z72955	Rivet Nut, 1/4NC x 165	4
5	Z76114	Flange Bolt, 1/4NC x 1"	4
6	Z72251	Hex Lock Nut, 1/2NC	16
7	2031L107	Valve Cover	1
8	Z73151	SAE Washer, 1/2"	12
9	Z71515	Hex Bolt, 1/2NC x 1-1/2"	12
10	Z72521	Serrated Flange Locknut, 5/16NC	1
11	Z96503	Manual Tube, 3-1/2" Short	1
12	2031W103	Weldment, Skidsteer Mount	1

Item No.	Part No.	Description	Qty
13	Z71565	Hex Bolt, 1/2NC x 6-1/2"	4
14	Z51471	Elbow 90, MJIC x FP 0808	2
15	Z51112	Pipe Nipple, MP08 x 8"	1
16	2011C1014	Barrel, 4"	1
17	Z51111	Pipe Nipple, MP08 x 7"	1
18	Z72231	Hex Lock Nut, 3/8NC	1
19	Z71325	Hex Bolt, 3/8NC x 2-1/2"	1
20	Z72251	Hex Lock Nut, 1/2NC	3
21	2014S421	Plate, Cylinder Retaining (Bolt)	1
22	Z71555	Hex Bolt, 1/2NC x 5-1/2"	3
23	2014W402	Weldment, Sliding Wedge	1

Hydraulic Cylinder Detail

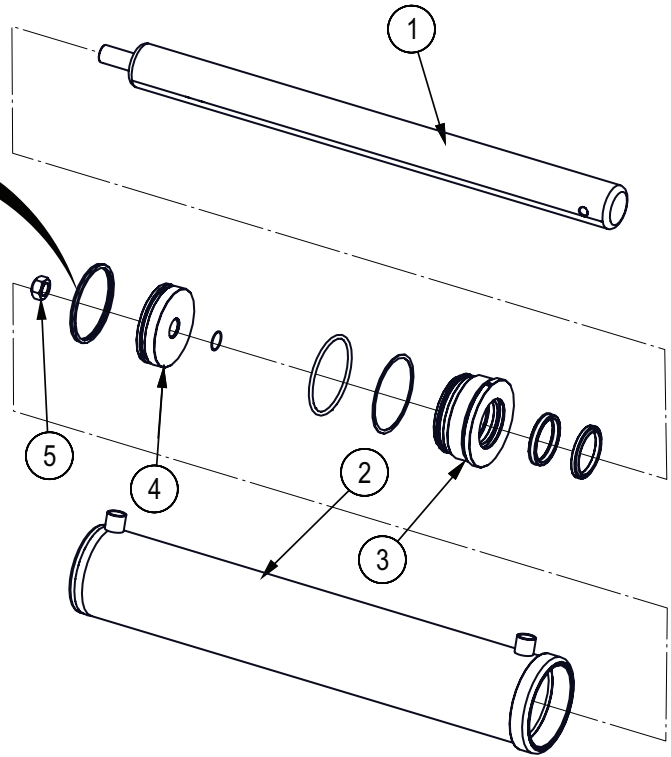
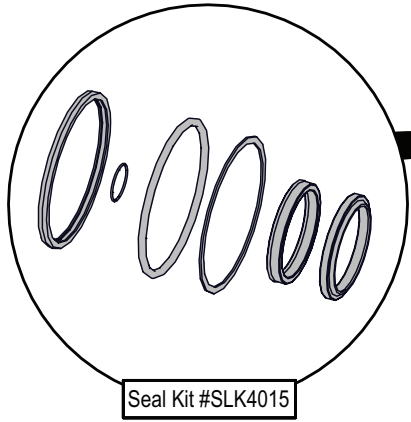

Item No.	Part No.	Description	Qty
1	2011C1012	Rod, 1-1/2 x 1	1
2	2011C1014	Barrel, 4"	1
3	G400-150S	Gland, 4" x 1-1/2"	1
4	P100-400SP	Piston, 4-" Bore	1
5	Z72276	Hex Lock Nut, 1NF GR8	1

Hydraulic Circuit S/N 120554 to 120905

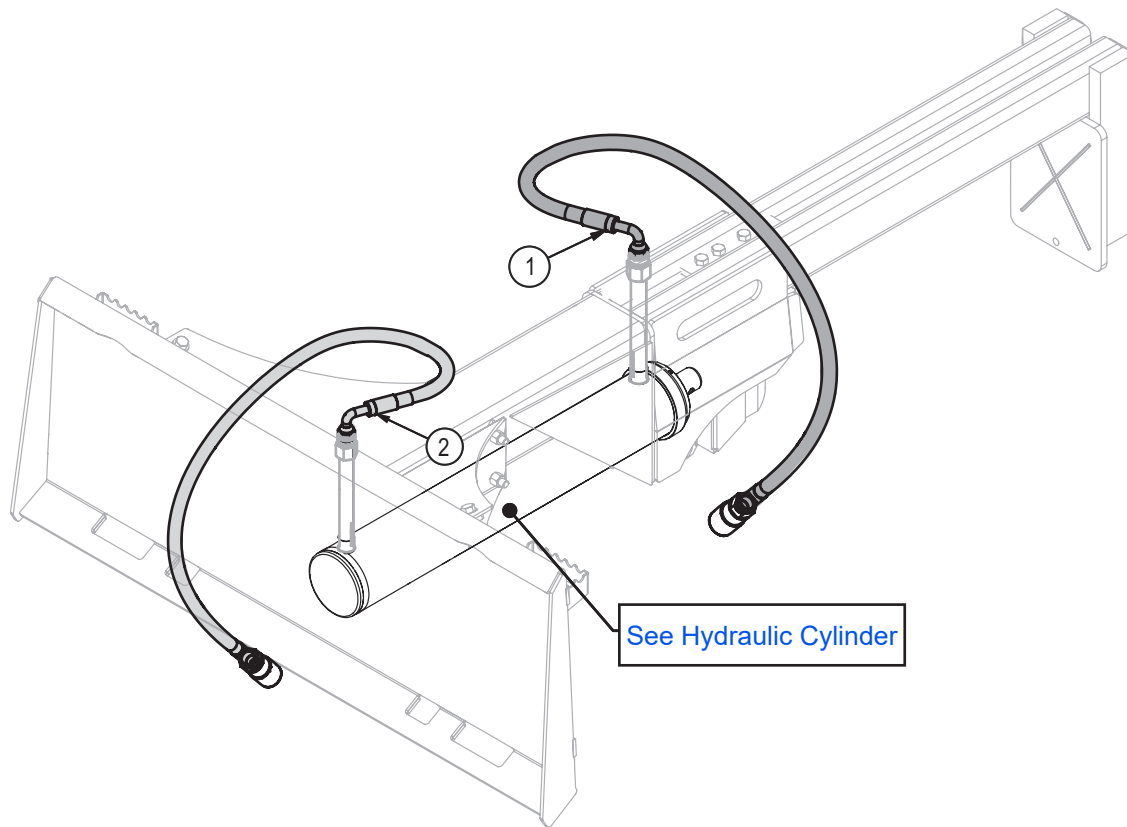

Item No.	Part No.	Description	Qty
1	Z52311	1/2" Hose, MP08 x MP08 x 72"	1
2	Z52312	1/2" Hose, MP08 x MP08 x 96"	1

Hydraulic Circuit S/N 120906 and Up

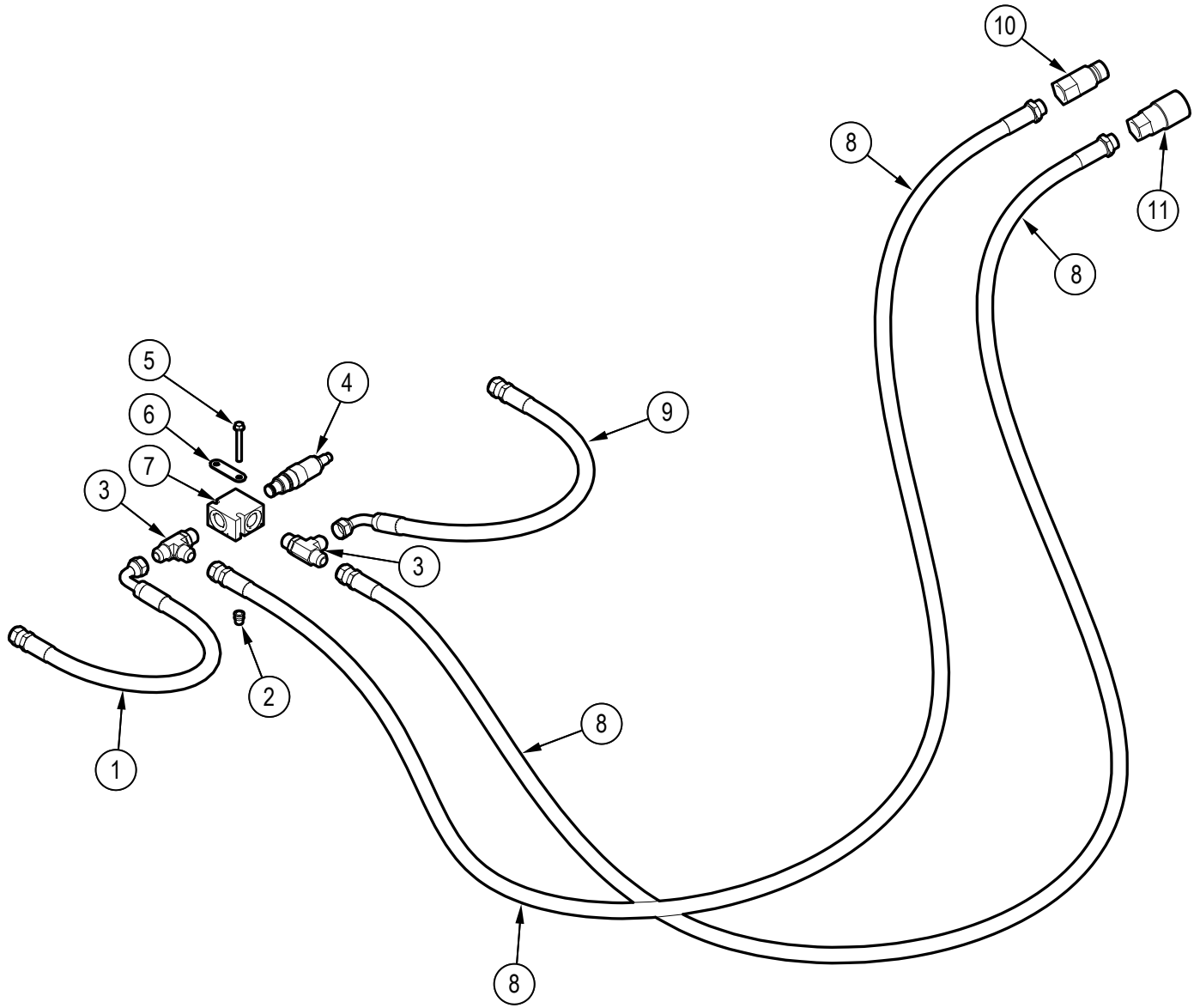

Item No.	Part No.	Description	Qty
1	2031F004	1/2" Hose, FJIC08 x 90FJIC08 x 18"	1
2	Z72955	Rivet Nut, 1/4NC x 165	2
3	Z51673	Tee, MJIC x MORB x MJIC 080808	2
4	Z56409	Cartridge, Pressure Reducing	1
5	Z76116	Flange Bolt, 1/4NC x 2"	2

Item No.	Part No.	Description	Qty
6	2031L108	Washer, Relief Valve	1
7	Z56921	Valve Housing, 2-way SAE08	1
8	2031F003	1/2" Hose, FJIC08 x MP08 x 90"	2
9	2031F005	1/2" Hose, FJIC08 x 90FJIC08 x 26"	1
10	Z51919	Flat-Face Coupler, FP08 x M ISO	1
11	Z51920	Flat-Face Coupler, FP08 x F ISO	1

Decal Layout

IMPORTANT! If parts are replaced that have safety signs on them, new signs must be applied. Safety signs must always be replaced if they become damaged, are removed, or become illegible.

Safety signs are included in the product decal kit available from your authorized dealer. Decals are not available separately.

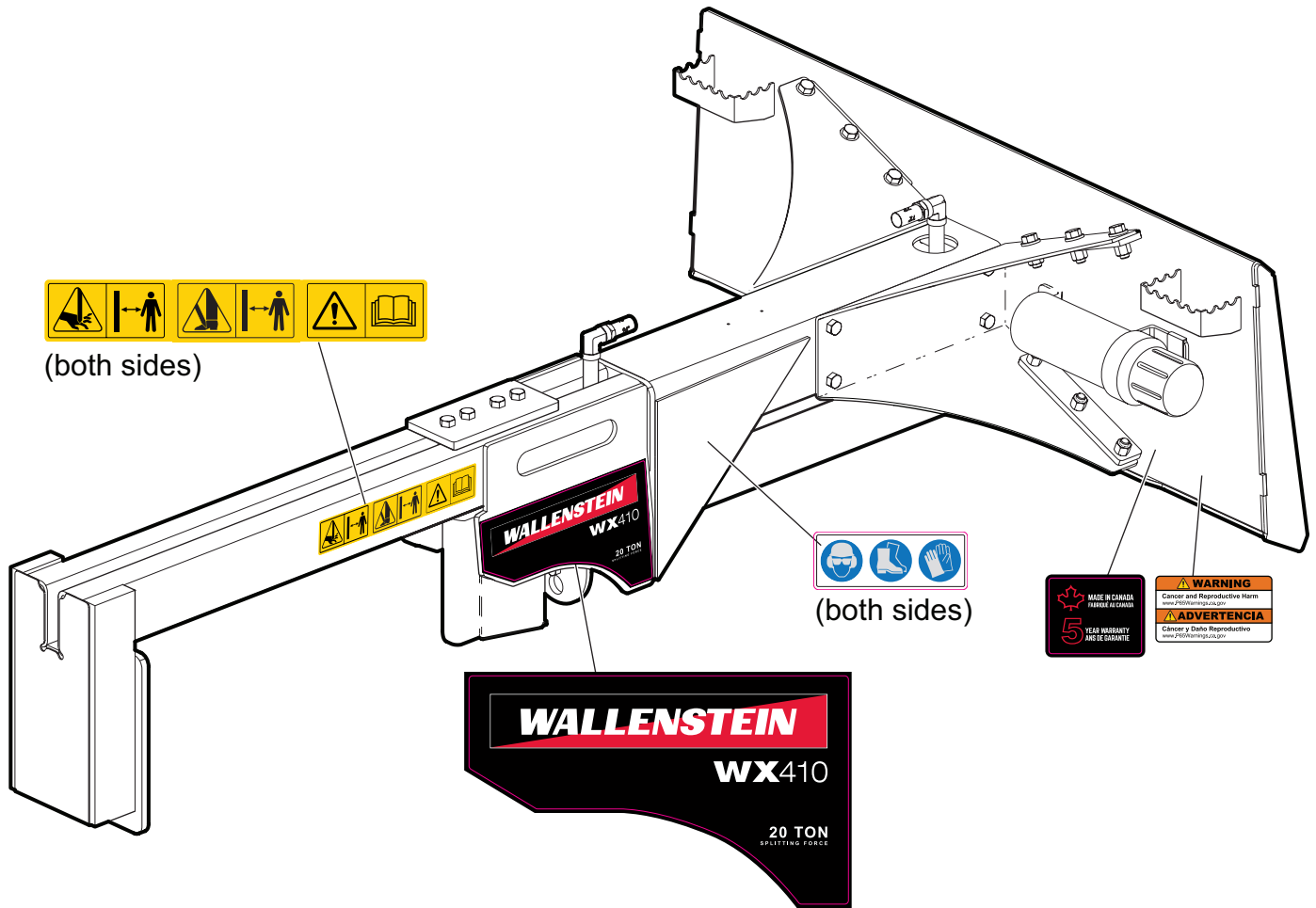

Accessories

Call your dealer for pricing and availability

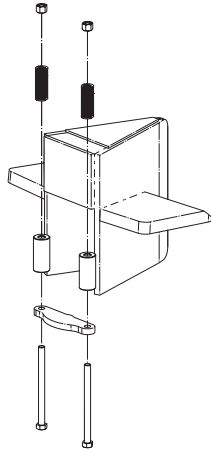
**#4120 4 WAY WEDGE**

Boost your productivity and make quick work out of logs by splitting four pieces at once. This is an ideal way to save time.

Common Bolt Torque Values

Checking Bolt Torque

The tables shown give correct torque values for various bolts and capscrews. Tighten all bolts to the torque values specified in the table, unless indicated otherwise. Check tightness of bolts periodically.

IMPORTANT! If replacing hardware, use fasteners of the same grade.

IMPORTANT! Torque figures indicated in the table are for non-greased or non-oiled threads. Do not grease or oil threads unless indicated otherwise. When using a thread locker, increase torque values by 5%.

 **NOTE:** Bolt grades are identified by their head markings.

Imperial Bolt Torque Specifications

Bolt Diameter	Torque Value					
	SAE Gr. 2		SAE Gr. 5		SAE Gr. 8	
	lbf•ft	N•m	lbf•ft	N•m	lbf•ft	N•m
1/4"	6	8	9	12	12	17
5/16"	10	13	19	25	27	36
3/8"	20	27	33	45	45	63
7/16"	30	41	53	72	75	100
1/2"	45	61	80	110	115	155
9/16"	60	95	115	155	165	220
5/8"	95	128	160	215	220	305
3/4"	165	225	290	390	400	540
7/8"	170	230	420	570	650	880
1"	225	345	630	850	970	1320



SAE Gr. 2



SAE Gr. 5



SAE Gr. 8

Metric Bolt Torque Specifications

Bolt Diameter	Torque Value			
	Gr. 8.8		Gr. 10.9	
	lbf•ft	N•m	lbf•ft	N•m
M3	0.4	0.5	1.3	1.8
M4	2.2	3	3.3	4.5
M6	7	10	11	15
M8	18	25	26	35
M10	37	50	52	70
M12	66	90	92	125
M14	83	112	116	158
M16	166	225	229	310
M20	321	435	450	610
M30	1,103	1 495	1,550	2 100



8.8



10.9

Hydraulic Fitting Torque Values

Tightening Flare Type Tube Fittings

1. Check flare and flare seat for defects that might cause leakage.
2. Align tube with fitting before tightening.
3. Hand-tighten swivel nut until snug.
4. To prevent twisting the tube, use two wrenches. Place one wrench on the connector body and tighten the swivel nut with the second. Torque to values shown.

If a torque wrench is not available, use the FFFT (Flats From Finger Tight) method.

Hydraulic Fitting Torque					
Tube Size OD	Hex Size Across Flats	Torque value		Flats From Finger Tight	
		lbf•ft	N•m	Flats	Turns
3/16	7/16	6	8	2	1/6
1/4	9/16	11–12	15–17	2	1/6
5/16	5/8	14–16	19–22	2	1/6
3/8	11/16	20–22	27–30	1-1/4	1/6
1/2	7/8	44–48	59–65	1	1/6
5/8	1	50–58	68–79	1	1/6
3/4	1-1/4	79–88	107–119	1	1/8
1	1-5/8	117–125	158–170	1	1/8

Values shown are for non-lubricated connections.