

WALLENSTEIN

BY EMB MFG INC.

EMB Manufacturing Inc.
4144 Boomer Line · St. Clements, On · N0B 2M0 · Canada
Ph: (519) 699-9283 · Fax: (519) 699-4146
www.wallensteinequipment.com

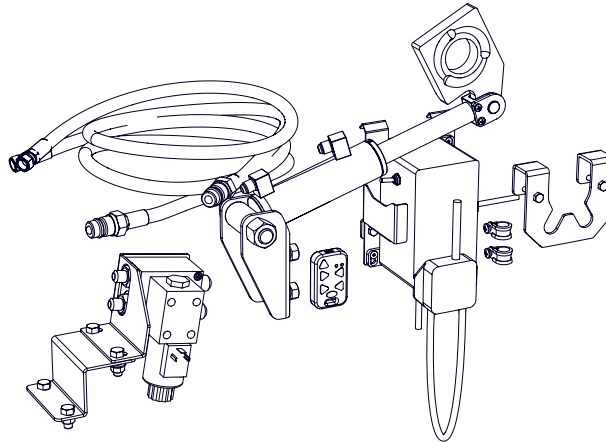

F200 / F205

SKIDDING WINCH

REMOTE CONTROL KIT Installation / Operating Instructions

Kit #F200 FITS: FX65, FX85, FX90 & FX110

Kit #F205 FITS: FX120 & FX140

This is a dealer only installation kit.

This kit should be installed by qualified technicians familiar with hydraulics. Please read these instructions before attempting to assemble, install and operate this kit

Note: This kit requires 1-2 GPM hydraulic flow and a 12 VDC power source.



This Safety Alert symbol means

ATTENTION! BECOME ALERT! YOUR SAFETY IS INVOLVED!

The Safety Alert symbol identifies important safety messages in this instruction. When you see this symbol, be alert to the possibility of personal injury or death. Follow the instructions in the safety message.

TABLE OF CONTENTS

DISASSEMBLE.....	4
PREPARE MOUNTING HOLES	5
INSTALL COMPONENTS	6
ADJUST SOLENOID	8
FX90 & FX110.....	8
ADJUST CYLINDER	9
ELECTRICAL HOOK-UP	10
HYDRUALIC HOOK-UP.....	10
SAFETY LABEL	10
HOW TO INSTALL SAFETY SIGNS:.....	10
REMOTE CLUTCH CONTROL.....	11
MANUAL CLUTCH CONTROL	11
REMOTE CONTROL	12
BOLT TORQUE.....	13
HYDRAULIC FITTING TORQUE	14
SPECIFICATIONS	14
CYLINDER / CLUTCH ASSEMBLY	15
RECIEVER ASSEMBLY	15
SOLENOID VALVE ASSEMBLY	16
FOR FX205 ONLY	16
CYLINDER SEAL INSTALLATION.....	17
HYDRAULIC CYLINDER DETAIL.....	17

Accessory Installation Instructions

SKIDDING WINCH REMOTE CONTROL KIT

-  Always wear the appropriate safety gear when installing this kit or working around the machine. This includes but is not limited to:
- Hard hat for protection to the head.
 - Safety glasses protection for the eyes.
 - Heavy gloves for hand protection.
 - Safety shoes with slip resistant soles and steel toes.

 **Caution:** this kit is constructed of heavy gauge steel, be sure to use caution moving and installing the kit, avoid dropping or pinching body parts on corners and edges of the kit.

Note: This kit requires 1 - 2 GPM hydraulic flow and a 12 VDC power source.

Kit #F200 is designed specifically to work with models FX65, FX85, FX90 & FX110.

Kit #F205 is designed specifically to work with models: FX120 & FX140

The **#F200 & F205** kit comes unassembled. Illustrations show typical assembly. This assembly procedure is one time only. Once assembled regular maintenance and only minor adjustments are required.

This kit will work on older version skidding winches, and will require drilling mounting holes. Newer skidding winches will have the necessary mounting holes and will not require any drilling.

For Illustration Purposes the FX65 is shown, but the assembly procedure is similar for all models

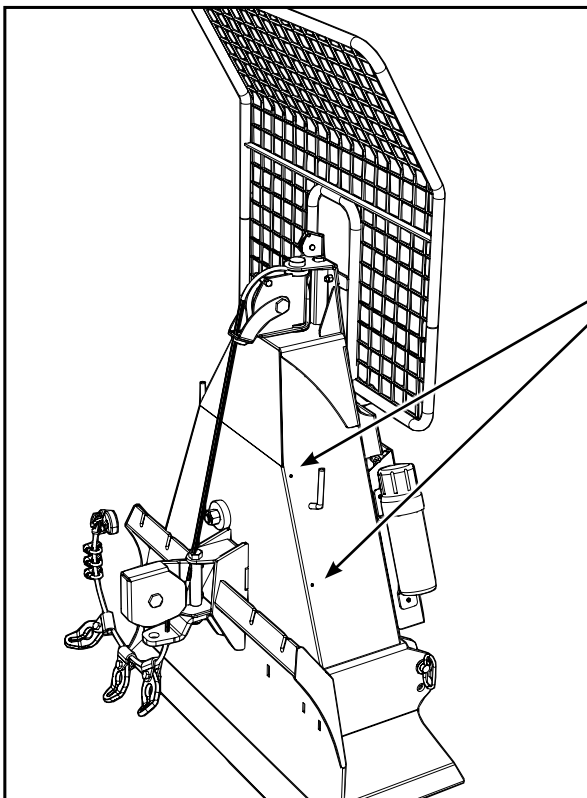

Note: As an indicator, Skidding Winches that have these mounting holes will not require drilling. Skip "Prepare Mounting Holes" drilling procedures.

 Review your winch manual for safe operating and handling procedures before beginning work.

Unpack the remote kit, using the parts list in the back of this manual check that all parts are included. All hardware and small parts are packaged in a plastic hardware bag.

DISASSEMBLE

- a. Carefully begin removing components to gain access to the clutch assembly.
- b. Remove the 2 bolts that hold on the lower protective shield, and remove the shield. Untie the clutch lever rope and remove.

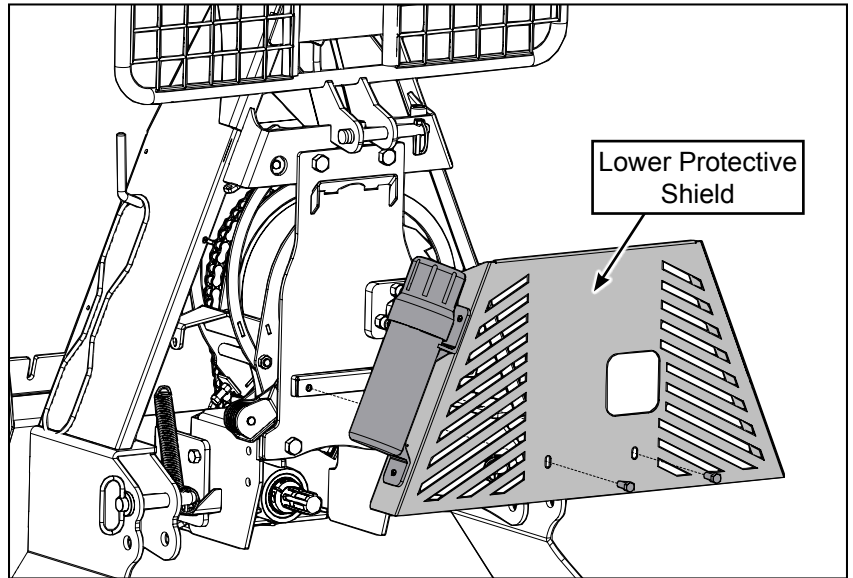

- c. Next remove the 4 x bolts and the main drum shaft nut. Begin removing the clutch back support plate, disconnect the clutch lever spring as you pull away the back, finish removing the back.
- d. Finish removing the clutch lever spring and set it aside. It will not be required for re-assembly.
- e. Remove the brake arm spring. This will make installation of the new components easier.

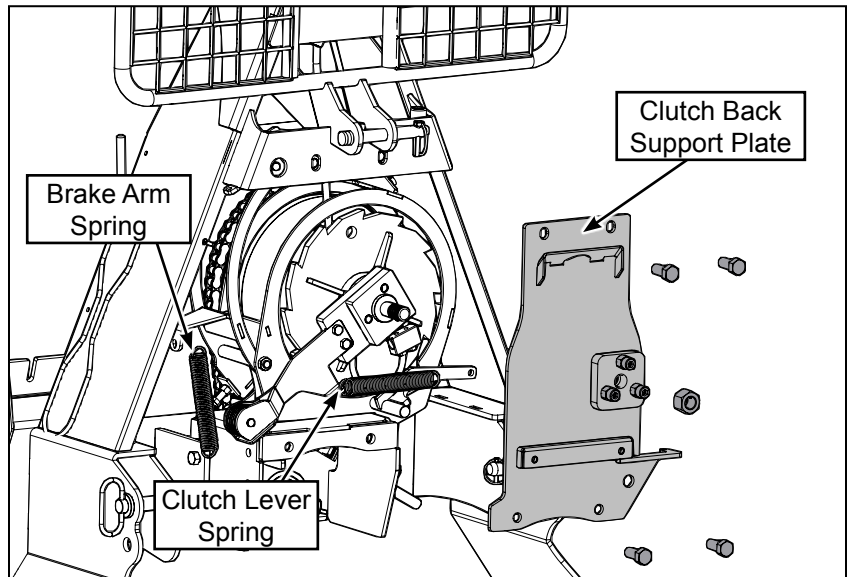

- f. Next carefully begin to remove the outer clutch block, place your hand under the clutch block to catch the 3 ball bearings between the block and lever assembly.
- g. Remove the clutch lever assembly and set it aside. It will not be required for re-assembly.

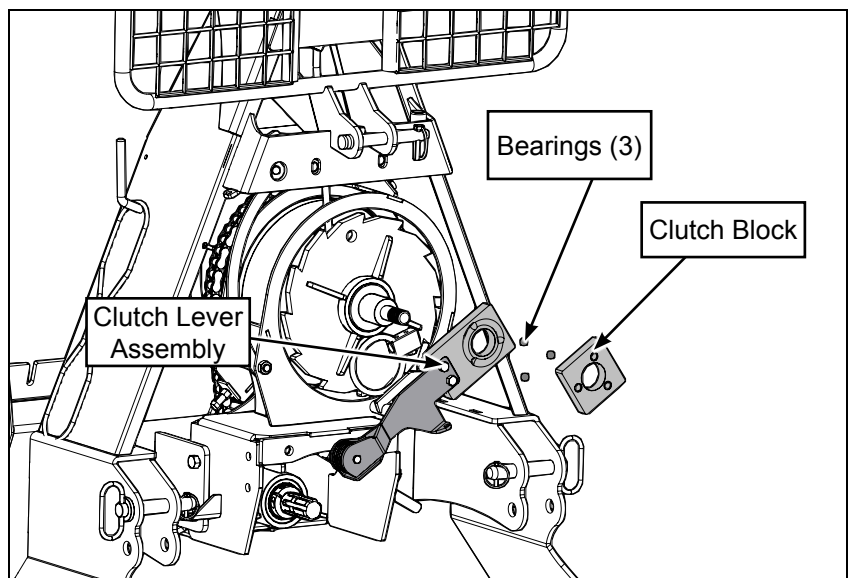

PREPARE MOUNTING HOLES

Previous versions of the skidding winches will require drilling to mount the remote control components. Follow the instructions and diagrams for hole size and locations.

- a. Drill the mounting holes for the "P" clamps: measure from the base of the "A" frame,
- first hole : 8.0" (20cm)
 - second hole 18.5" (47cm)
 - drill 2 holes using a 5/16" (8mm) drill bit

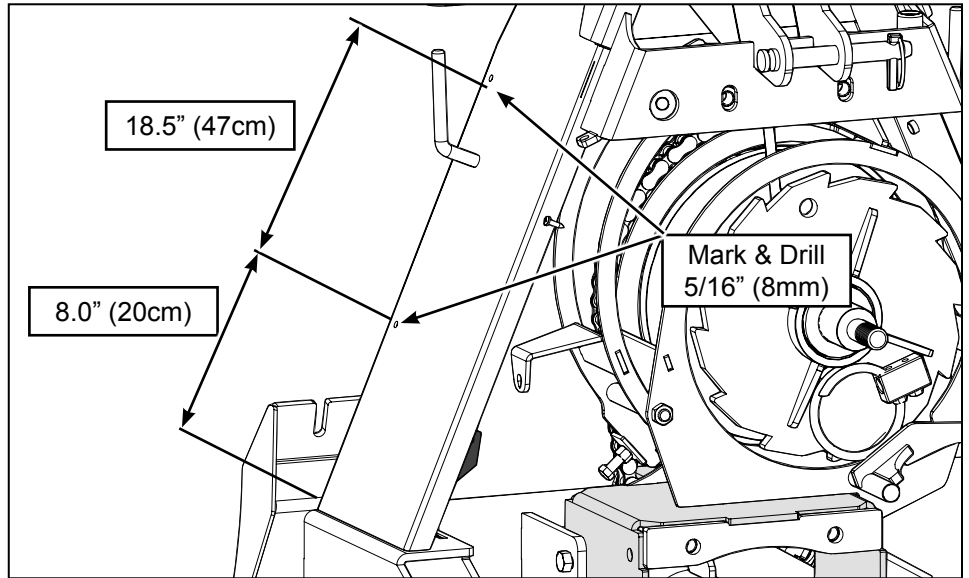

- b. Drill the mount holes for the hydraulic bracket:
- measure 4.7" (12cm) from the front edge of the winch stand, and
 - place the hydraulic bracket at the point, and align the long edge on the inside edge of the stand
 - hold the bracket in place, use it as a template and use the mounting holes to mark the location of the 2 holes to be drilled
 - drill 2 holes using a 7/16" (11mm) drill bit

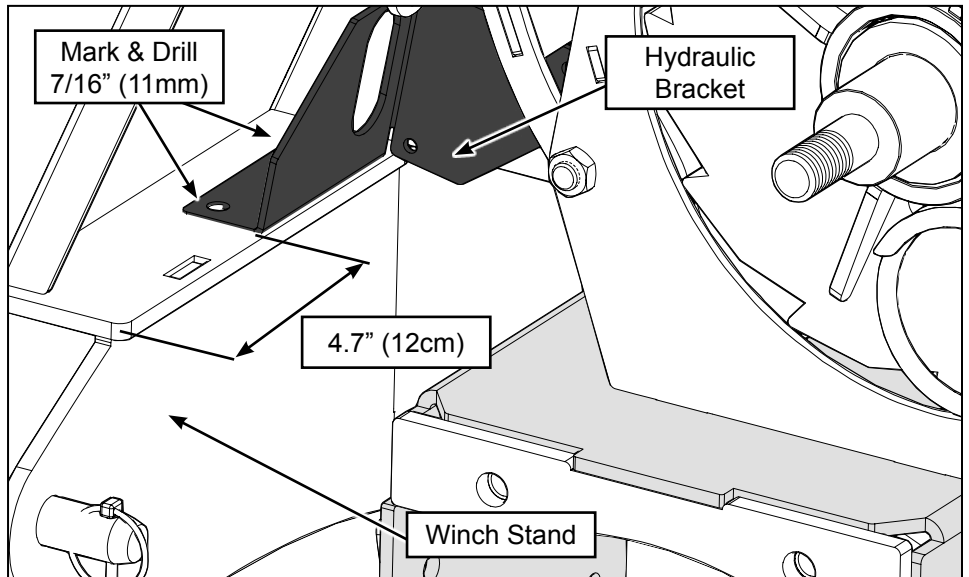

- c. Drill the mount holes for the hydraulic cylinder:
- align the side of the cylinder bracket to the face of the clutch base.
 - align the top edge of the bracket to the top face of the clutch base.
 - hold the bracket in place, use it as a template and use the mounting holes to mark the location of the 2 holes to be drilled
 - drill 2 holes using a 17/32" (15mm) drill bit

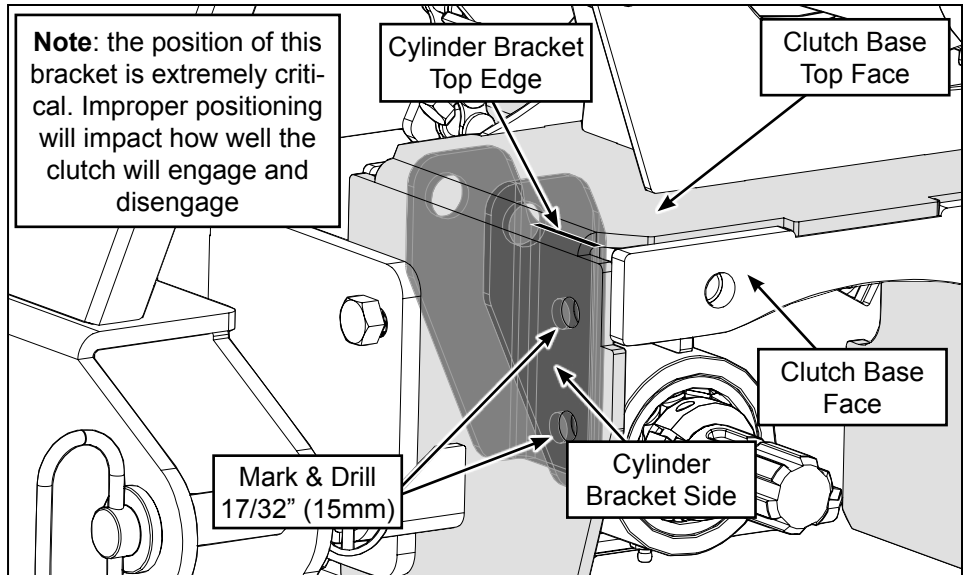

INSTALL COMPONENTS

Follow these instructions to install all the components of the remote kit.

- a. Install the solenoid valve assembly using two $\frac{3}{8}$ " x 1.0" hex bolts and nuts. Tighten down the assembly (see torque chart)
The assembly is shown with out the hydraulic hoses attached only for clarity. Hoses should be attached before installing this component.

Note: FX90, FX110, FX120 & FX140 require an extra bracket to be installed on the solenoid assembly (included in the kit). To keep the assembly clear of the winch leg stand when it is retracted

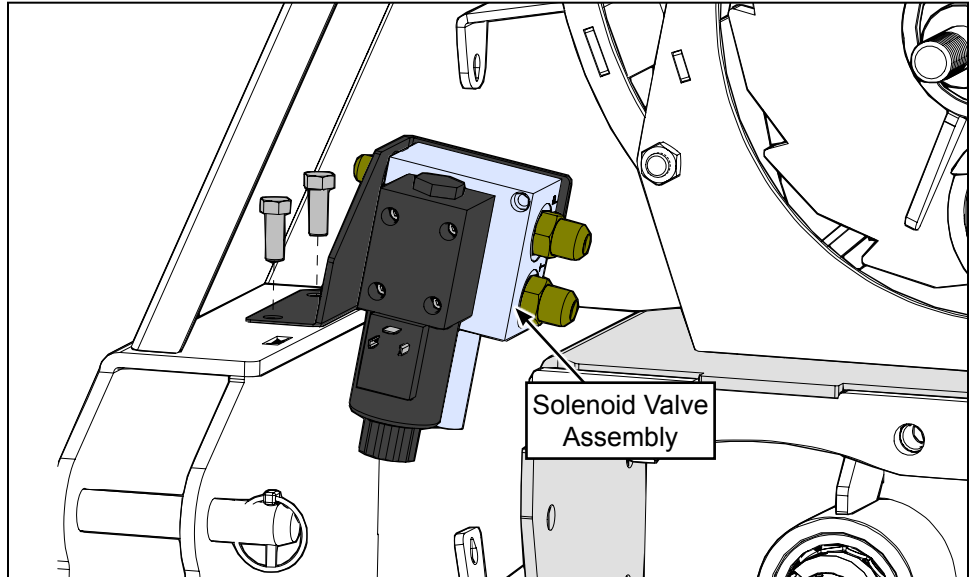

- b. Slide the hydraulic cylinder assembly over the main shaft.
c. Insert the two $\frac{1}{2}$ " x $1\frac{1}{4}$ " hex bolts thru the mounting holes
d. Place two $\frac{1}{2}$ " washers over each of the bolts and place the cylinder bracket over the bolts and hand tighten with the $\frac{1}{2}$ " flange nuts. Do not tighten down this assembly, adjust may be required before final assembly.
e. Attach hydraulic hoses to the cylinder, see diagram for correct connection, tighten. (see hydraulic fitting torque chart.)
f. Slide the lock dog for the drum sprocket in place.

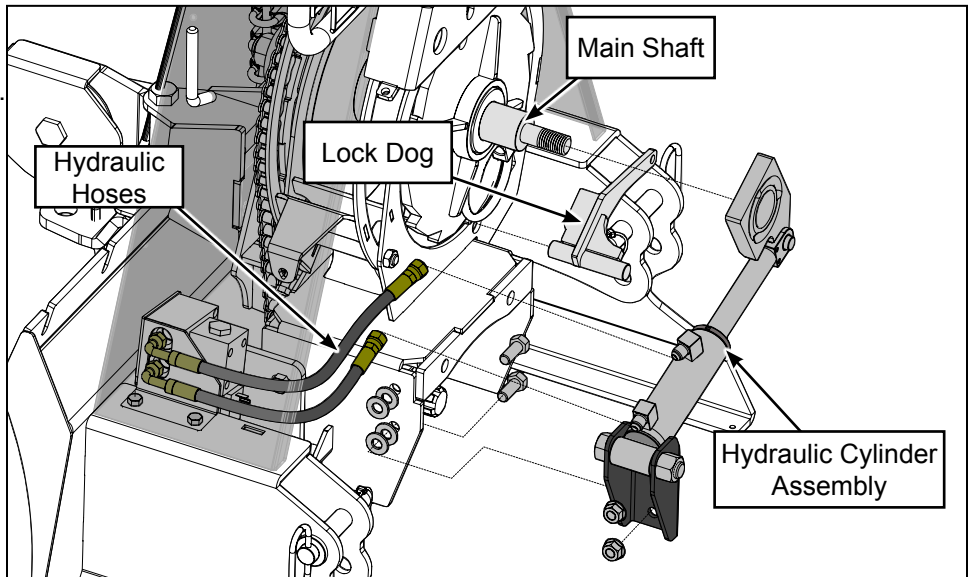

- g. Lightly grease the clutch block, and place the 3 ball bearings in the bearing race (grease should hold in the bearings), and install over the main shaft.
h. Align the clutch back plate with
 - the main shaft,
 - the lock dog pin,
 - clutch blocki. Install the back plate into place, fasten the four $\frac{5}{8}$ " x $1\frac{1}{2}$ " hex bolts and nuts.
j. Install the $\frac{7}{8}$ " hex nut on the main shaft. Fasten all bolts & nuts (see torque chart)

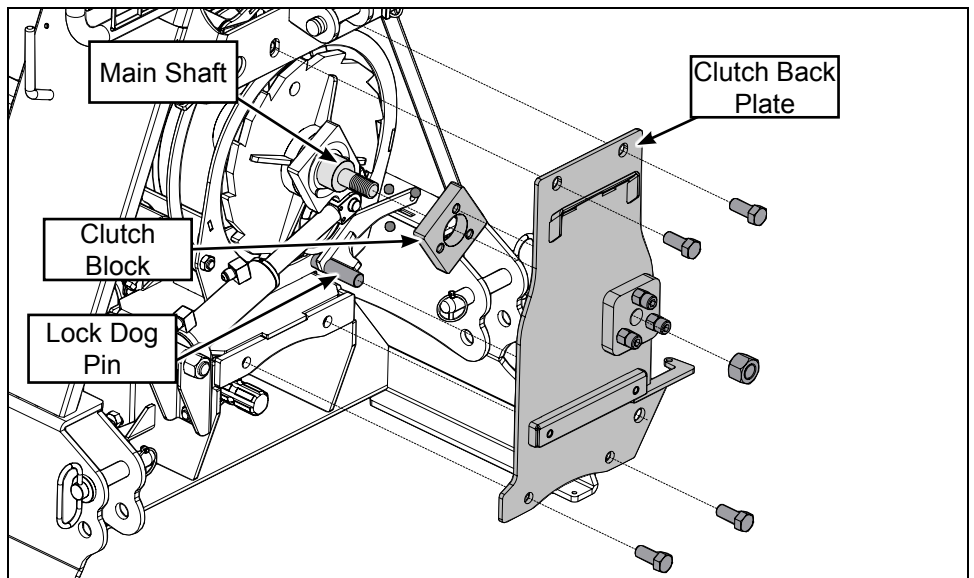

- k. Install the remote receiver: Have a helper steady the safety screen, remove the two hex bolts and nuts that hold the safety screen to the skidder.
- l. Align the remote bracket to the safety screen mounting holes and replace the hex bolts / nuts.
- m. Install the hose hanger on the safety screen as shown, secure the hose hanger with the two 1/4" x 2.0 hex bolts and nuts.
- n. Tighten all hex bolts and nuts. (see torque chart)

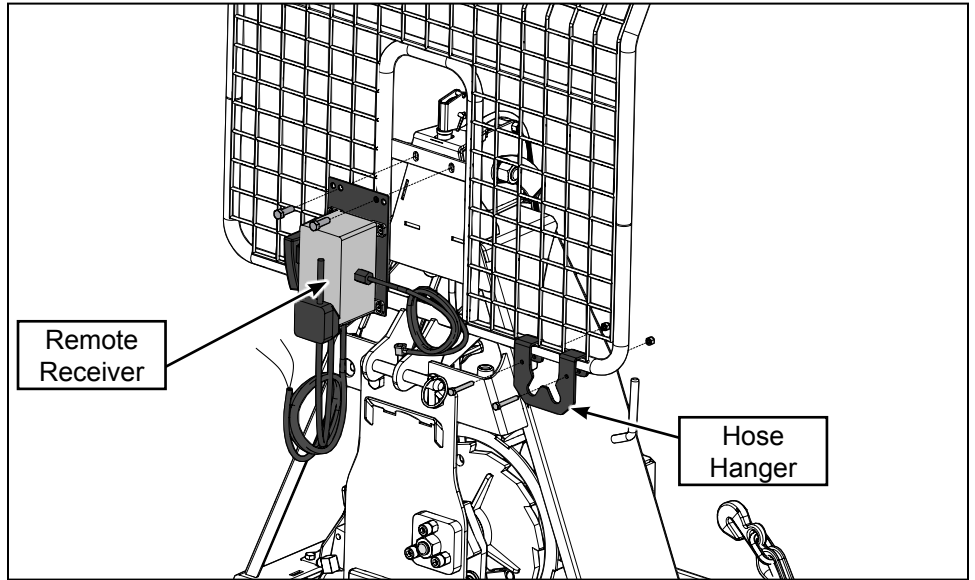

- o. Connect the solenoid cable from the remote receiver to the solenoid assembly: Unwind and route the cable as shown in the illustration
- p. Fit the two rubberized cable clamps around the solenoid cable.
- q. Install and secure the clamps to the "A" frame using a 1/4" x 3/4" machine screws and nuts on each clamp.
- r. Plug the end of the cable into the solenoid assembly.
- s. The remaining cable should be connected to the tractor power, A DC connection with a voltage of 12 VDC is required.

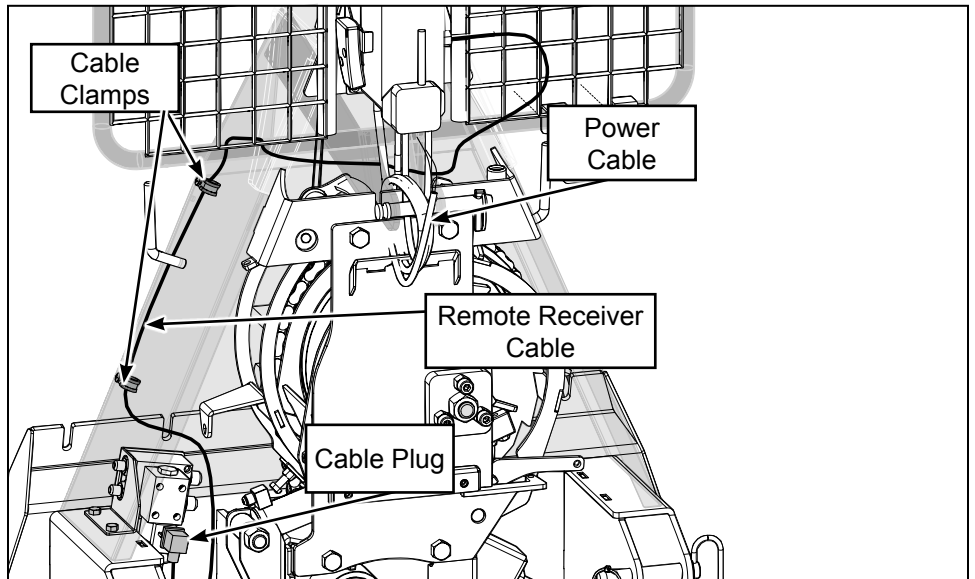

- t. Finally install the brake arm spring and hook the hydraulic hoses to the hose hanger.

Installation of the remote components is now complete, final adjustments are required and are outlined in the following steps.

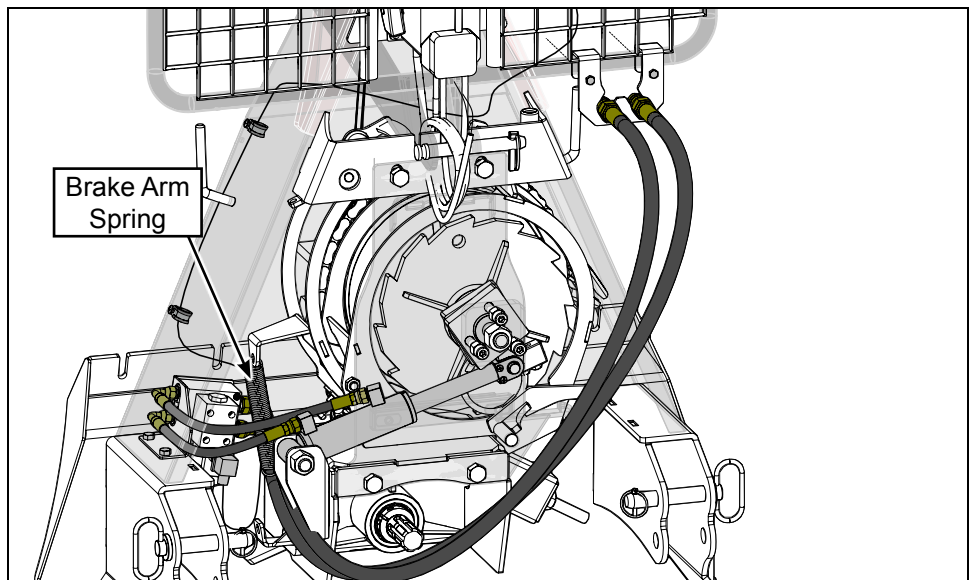

ADJUST SOLENOID

Follow these instructions to make adjustments the components of the remote kit for your model of winch.

Depending on your model, an adjustment to the hydraulics must be made. This adjustment affects how well the hydraulic cylinder engages the clutch.

- a. In the solenoid valve assembly, there is a control valve. On the controller you will find the pressure relief adjusting screw, see the illustration.

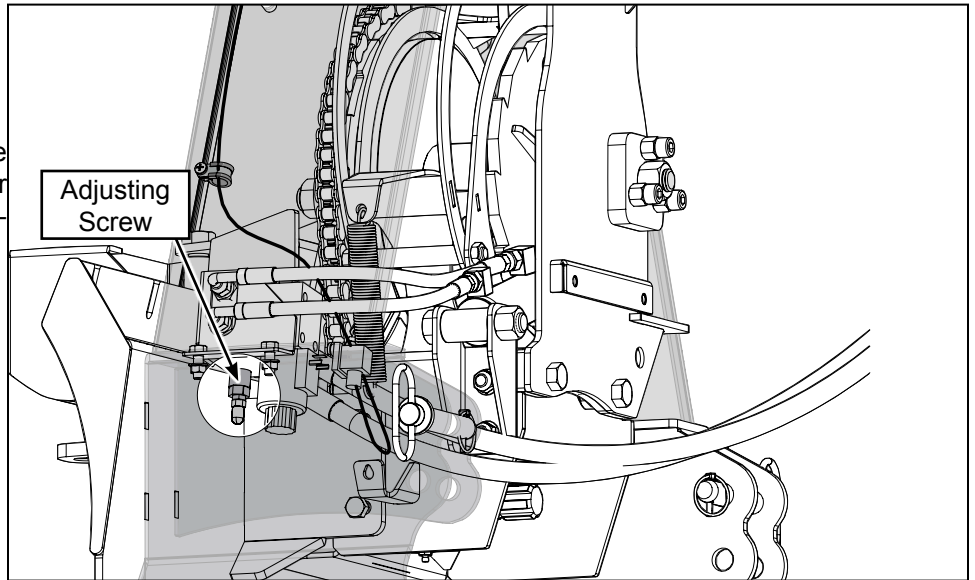

- b. Remove the adjuster cap: use a socket or wrench and turn counter clockwise to remove the cap.

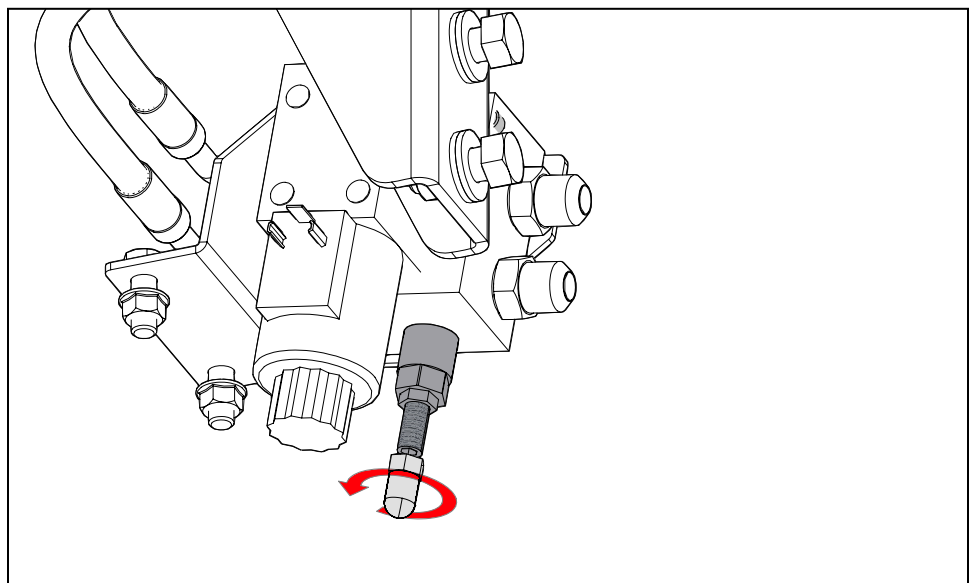

- c. Once the cap is removed insert a correct sized allen key and make the adjustment clockwise. See the chart and make the number of turns required for your model of skidding winch.

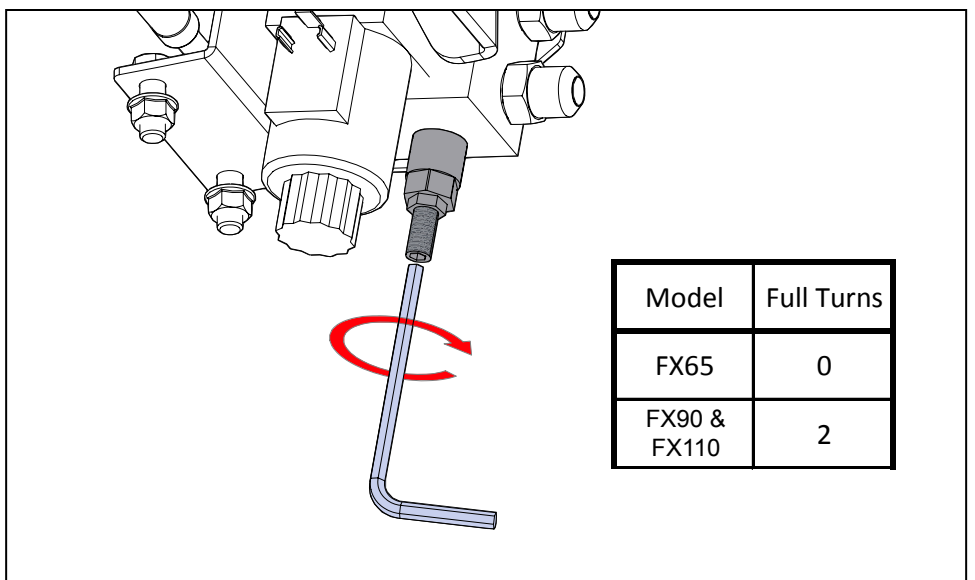

Model	Full Turns
FX65	0
FX90 & FX110	2

ADJUST CYLINDER

This adjustment may be required for all models, and affects how well the hydraulic cylinder will disengage. For accurate adjustment, ensure that:

- the cylinder is fully extended
- the cylinder bracket bolts are firmly hand tightened.

Note the position of the clutch blocks.

- If the blocks are aligned square then no adjustment is required, tighten the nuts and bolts.
- If the blocks do not line up square and the remote clutch block is slightly skewed with the top corner of the remote clutch block extended past the **right side** of the stationary clutch block (as illustrated) that is also ok, no adjustment is required, tighten the nuts and bolts.
- If the blocks do not line up square and the remote clutch block is slightly skewed with the top corner of the remote clutch block extended past the **left side** of the stationary clutch block (as illustrated) that is an indication that adjustment is required:
- Washers will need to be installed between the cylinder bracket and clutch base. This will move the cylinder assembly away from the stationary block, which will rotate and align the clutch block.
- Carefully remove the flange nuts that hold the cylinder bracket to the clutch base, move the bracket out and add another washer to each bolt.
- Hand tighten the bracket with the flange nuts.
- Check the alignment of the clutch blocks, add more washers if required.
- Once the blocks are in proper alignment, replace the lower protective shield. Read thru the operation and use section before operating the winch.

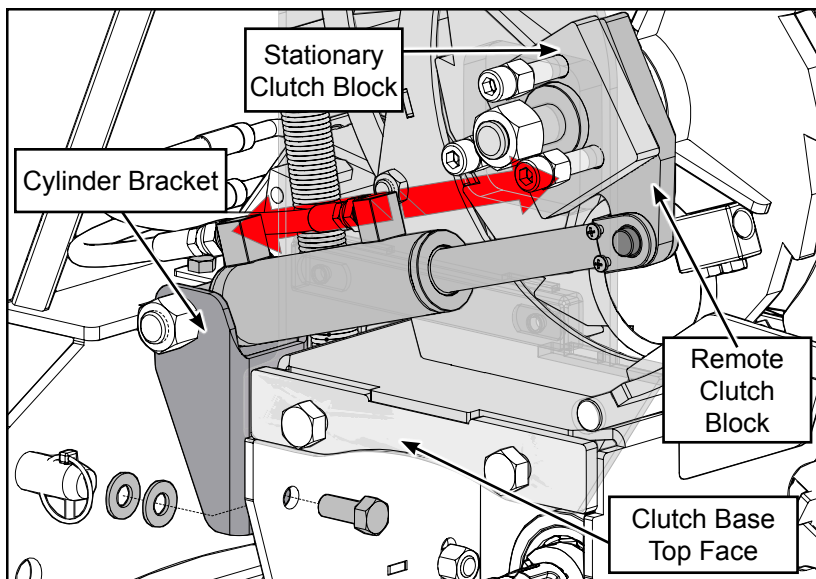
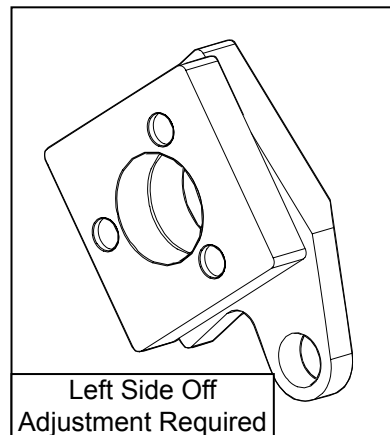
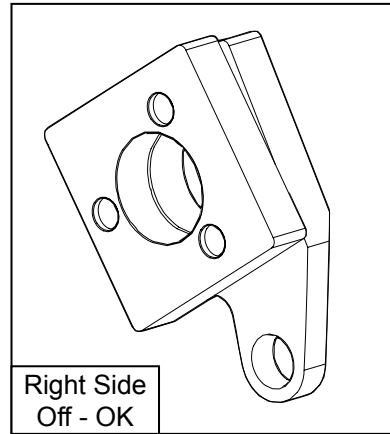
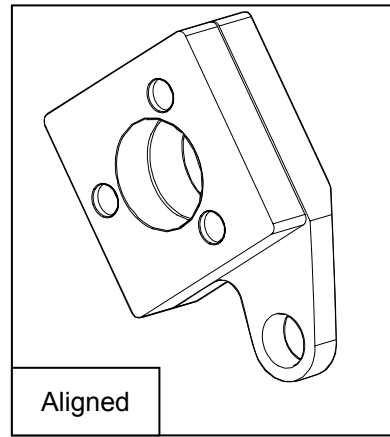

ELECTRICAL HOOK-UP

The P200 and P205 require electrical power to function. A 12VDC source from the tractor is required.

- 2 wire hookup:
 - white: positive
 - black: negative
- wire tips are supplied bare (no connector supplied).
- use a connector that works with your particular tractor (cigarette adaptor plug, trailer lighting plug, etc).
- connect to an auxilliary or accessorie circuit that can supply 12 VDC @ 1.5 amps while the unit is operating.

HYDRUALIC HOOK-UP

The P200 and P205 requires a hydraulic connection with 1 - 2 GPM flow to function.

- 2 hose hookup:
 - 1 x pressure
 - 1 x return
- Hydraulic hoses are supplied with Pioneer ball connectors.
- the kit is designed to work with tractors that have open centre hydrualic system able to deliver 1 - 2 GPM.

SAFETY LABEL

The kit contains a Caution label for hydraulics. The label must be applied as shown in the diagram

- Keep safety signs clean and legible at all times.
- Replace safety signs that are missing or have become illegible.
- Replaced parts that displayed a safety sign should also display the current sign.
- Safety signs in Section 3 each have a part number displayed with it. Use this part number when ordering replacement parts.
- Safety signs are available from your authorized Distributor or Dealer Parts Department or the factory.

HOW TO INSTALL SAFETY SIGNS:

- Be sure that the installation area is clean and dry.
- Be sure temperature is above 50°F (10°C).
- Determine exact position before you remove the backing paper.
- Remove the smallest portion of the split backing paper.
- Align the sign over the specified area and carefully press the small portion with the exposed sticky backing in place.
- Slowly peel back the remaining paper and carefully smooth the remaining portion of the sign in place.
- Small air pockets can be pierced with a pin and smoothed out using the piece of sign backing paper.

Caution: Hydraulic fluid under pressure, do not check for leaks with you hand or fingers when the system is pressurized. Serious injury will result. Concealed hydraulic connection: use caution when removing panels or guards.

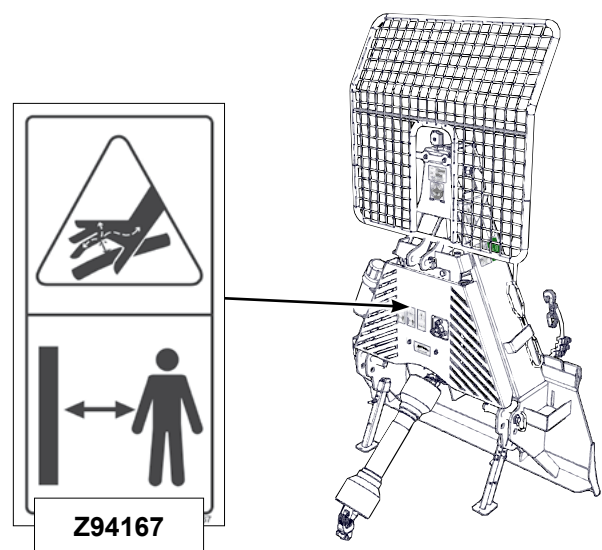

REMOTE CLUTCH CONTROL

The remote control actuates the hydraulic cylinder, engages the spring-loaded clutch, which starts or releases the cable retracting winch.

1. Engage Winch Clutch:

Press and hold the two buttons (1 & 4) simultaneously on the remote (see diagram) to engage the clutch and retract the cable. Releasing the buttons disengages the winch and the cable stops retracting.

The remote transmitter has a range of up to 100m (300 ft) and the receiver requires a 12 VDC connection.

2. Disengage Winch Clutch

Release the two buttons on the remote transmitter to disengage the clutch, and the winch will go into its free-wheeling status.

3. Operator Position:

To avoid potential hazards while pulling a load, the operator should be at least 10 ft (3 m) to the side of the machine while operating the winch.

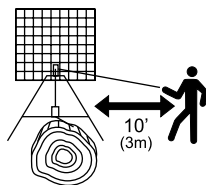

MANUAL CLUTCH CONTROL

(for remote units so equipped)

If for any reason the remote ceases to function the winch can still be operated manually by means of a toggle switch located on the side of the receiver.

The sideways throw, hold to run (momentary) switch actuates the hydraulic cylinder, engages the spring-loaded clutch, which starts or releases the cable retracting winch.

Because of the location of the switch, the manual clutch control must not be used on a continuous basis, and should only be used until the remote is back in service. Be aware of the cable the load it is pulling to avoid potential injury.

1. Engage Winch Clutch:

On the side of the receiving unit, press and hold the toggle switch to the right (see diagram) to engage the clutch and retract the cable.

2. Disengage Winch Clutch

Release the toggle and it will return to its original position to disengage the winch and the cable stops retracting, and the winch will go into its free-wheeling status.

3. Operator:

To avoid potential hazards while pulling a load, the operator should be fully aware of the cable and its load at all times. If the cable slips off or breaks under load, it could whip back to the winch and operator.

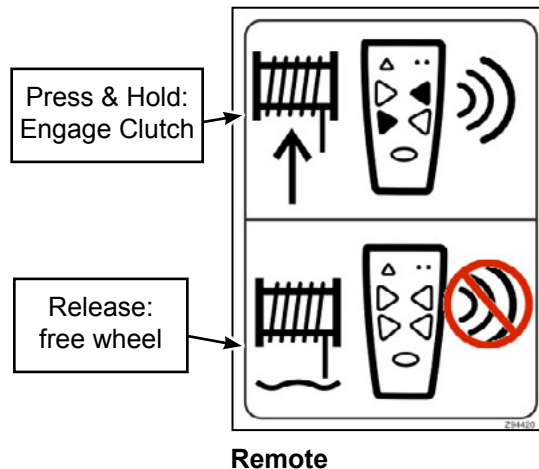
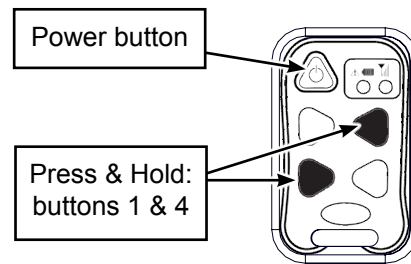

! Review your winch manual for safe operating and handling procedures before beginning work.

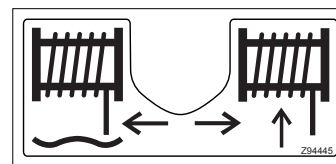

Normal Position - left:
Free Wheel

Press & Hold - right:
Engage Clutch

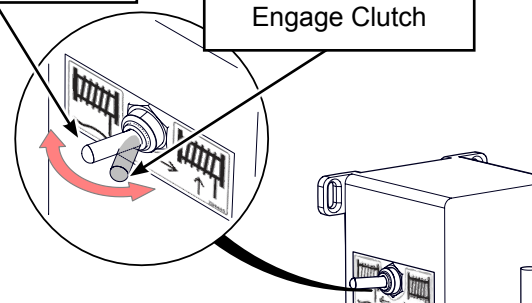

Remote Control Units: clean transmitter regularly with a damp cloth and mild detergent. Inspect electrical wiring for wear points or other damage. Repair as required. Inspect all connections for looseness or corrosion. Tighten and/or "seal" as necessary.

REMOTE CONTROL

The Wallenstein F200 / F210 remote winch control system enables remote control of the winching function, eliminating the need to make your way back to the FX winch to engage the clutch. (see control section for operation)

The remote control system consists of two components: the ergonomically designed transmitter and the equipment-mounted receiver module.

Micro Transmitter

Each radio transmitter is preprogrammed with a unique radio ID code. Each receiver is programmed to respond only to the radio transmitter with the ID code for which it is set. This feature allows multiple systems to work in close proximity to one another without interference.

The transmitter has two LED indicators. The green LED indicator flashes rapidly whenever there is communication between the transmitter and the receiver.

The red LED indicator starts blinking once every second when the battery voltage is low and requires replacement.

It also blinks when there is a problem with the system in the form of an error code. Count the blinks and call EMB for service.

Turn on: press and hold the power button on the transmitter until both LEDs turn on, then release. The green LED will flash rapidly when communication has been established. When the receiver is off, the green LED will flash slowly.

Sleep Time: the transmitter is factory set to turn off (sleep) after 15 minutes, when not in use. To change the time the transmitter waits before going to sleep, use the following procedure:

1. On the transmitter, press and hold POWER and buttons 3, 4, and 8.
2. Release the buttons. At this point, both lights will blink once per second.
3. On the transmitter, press one of the following buttons to adjust the sleep time.
 - a. 1 = 15 min
 - b. 2 = 30 min
 - c. 3 = 1 hr
 - d. 4 = 2 hr
 - e. 8 = sleep disabled
4. Sleep time programming complete.

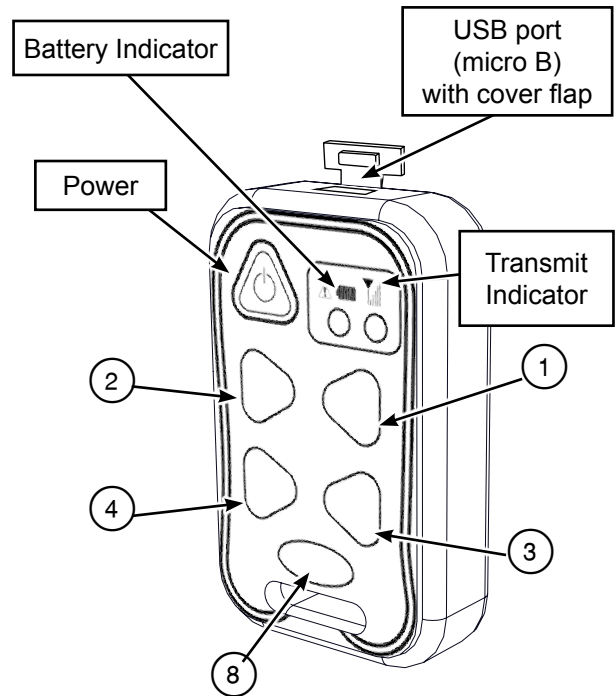

Transmitter

Batteries: Lithium-polymer battery is included. Thirty hours of actively transmitting operating life is a typical minimum with the batteries, before recharging is required.

The MICRO remote control key fob charges via a common micro-USB port (micro B).

Receiver

The remote receiver is mounted on the FX and controls the hydraulic actuator to engage the clutch.

It requires a 12 VDC connection for power, available from the tractor.

The remote receiver is encapsulated in plastic, for weather, vibration and shock resistance.

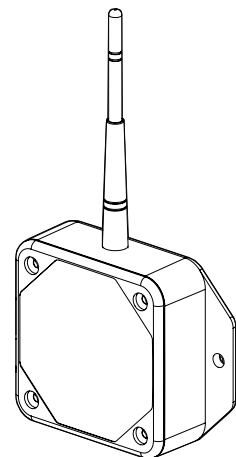

Receiver

BOLT TORQUE

CHECKING BOLT TORQUE

The tables shown below give correct torque values for various bolts and capscrews. Tighten all bolts to the torques specified in chart unless otherwise noted. Check tightness of bolts periodically, using bolt torque chart as a guide. Replace hardware with the same strength bolt.

ENGLISH TORQUE SPECIFICATIONS						
Bolt Diameter "A"	Bolt Torque*					
	SAE 2 (N.m) (lb-ft)		SAE 5 (N.m) (lb-ft)		SAE 8 (N.m) (lb-ft)	
1/4"	8	6	12	9	17	12
5/16"	13	10	25	19	36	27
3/8"	27	20	45	33	63	45
7/16"	41	30	72	53	100	75
1/2"	61	45	110	80	155	115
9/16"	95	60	155	115	220	165
5/8"	128	95	215	160	305	220
3/4"	225	165	390	290	540	400
7/8"	230	170	570	420	880	650
1"	345	225	850	630	1320	970

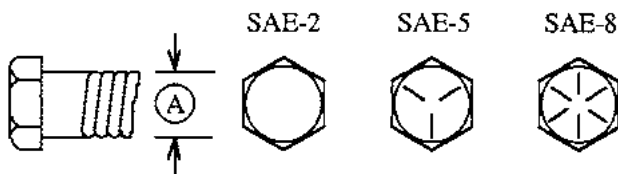

Torque figures indicated are valid for non-greased or non-oiled threads and heads unless otherwise specified. Therefore, do not grease or oil bolts or capscrews unless otherwise specified in this manual. When using locking elements, increase torque values by 5%.

METRIC TORQUE SPECIFICATIONS				
Bolt Diameter "A"	Bolt Torque*			
	8.8 (N.m) (lb-ft)		10.9 (N.m) (lb-ft)	
M3	0.5	0.4	1.8	1.3
M4	3	2.2	4.5	3.3
M5	6	4	9	7
M6	10	7	15	11
M8	25	18	35	26
M10	50	37	70	52
M12	90	66	125	92
M14	140	103	200	148
M16	225	166	310	229
M20	435	321	610	450
M24	750	553	1050	774
M30	1495	1103	2100	1550
M36	2600	1917	3675	2710

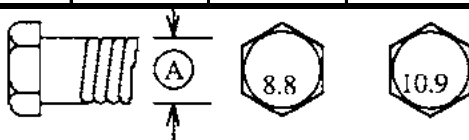

* Torque value for bolts and capscrews are identified by their head markings.

HYDRAULIC FITTING TORQUE

Tightening Flare Type Tube Fittings *

1. Check flare and flare seat for defects that might cause leakage.
 2. Align tube with fitting before tightening.
 3. Lubricate connection and hand tighten swivel nut until snug.
 4. To prevent twisting the tube(s), use two wrenches. Place one wrench on the connector body and with the second tighten the swivel nut to the torque shown.
- The torque values shown are based on lubricated connections as in reassembly.

HYDRAULIC FITTING TORQUE					
Tube Size OD	Nut Size Across Flats	Torque Value*		Recommended Turns To Tighten (After Finger Tightening)	
		(N.m)	(lb-ft)	(Flats)	(Turn)
(in.)	(in.)				
3/16	7/16	8	6	1	1/6
1/4	9/16	12	9	1	1/6
5/16	5/8	16	12	1	1/6
3/8	11/16	24	18	1	1/6
1/2	7/8	46	34	1	1/6
5/8	1	62	46	1	1/6
3/4	1-1/4	102	75	3/4	1/8
7/8	1-3/8	122	90	3/4	1/8

SPECIFICATIONS

F200 / F205 Remote Control Kit	voltage: 12 VDC amperage: 1.5 A 2 x AAA Batteries req'd (transmitter) 100m (300') Range hydraulic actuator: 1 -2 GPM flow required
---	---

CYLINDER / CLUTCH ASSEMBLY

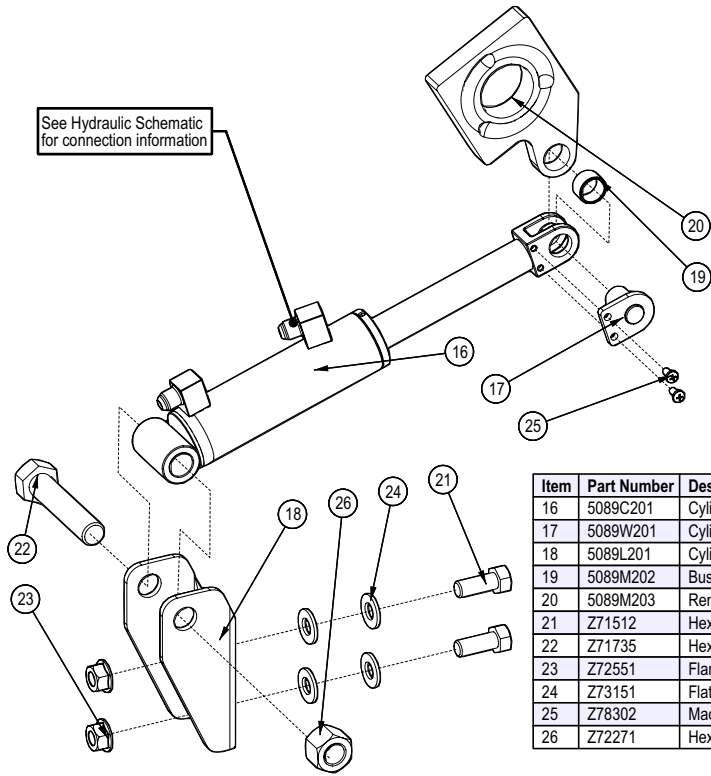

Item	Part Number	Description	Qty
16	5089C201	Cylinder, 1-1/2" x 3-1/2 Stroke	1
17	5089W201	Cylinder Pin	1
18	5089L201	Cylinder Base	1
19	5089M202	Bushing	1
20	5089M203	Remote Control Clutch Plate	1
21	Z71512	Hex Bolt, 1/2NC x 1-1/4	2
22	Z71735	Hex Bolt, 3/4NC x 3-1/2	1
23	Z72551	Flange Nut 1/2NC	2
24	Z73151	Flat Washer, 1/2	4
25	Z78302	Machine Screw, #10-32NF x 3/8	2
26	Z72271	Hex Lock Nut, 3/4NC	1

RECIEVER ASSEMBLY

Item	Part Number	Description	Qty
27	5089L205	Remote Box Mount	1
28	5089L209	Hose Hanger	1
29	Z62819	Rubberized Wire Clamp, 1/2"	2
30	Z66208	Dual State Remote Receiver	1
31	Z66209	Remote Handset for Z56208	1
32	Z71120	Hex Bolt, 1/4NC x 2	2
33	Z72211	Hex Lock Nut, 1/4NC	2
34	Z72752	Machine Nut, #10-32NF	4
35	Z75202	FHCS, #10-32NF x 3/8	4

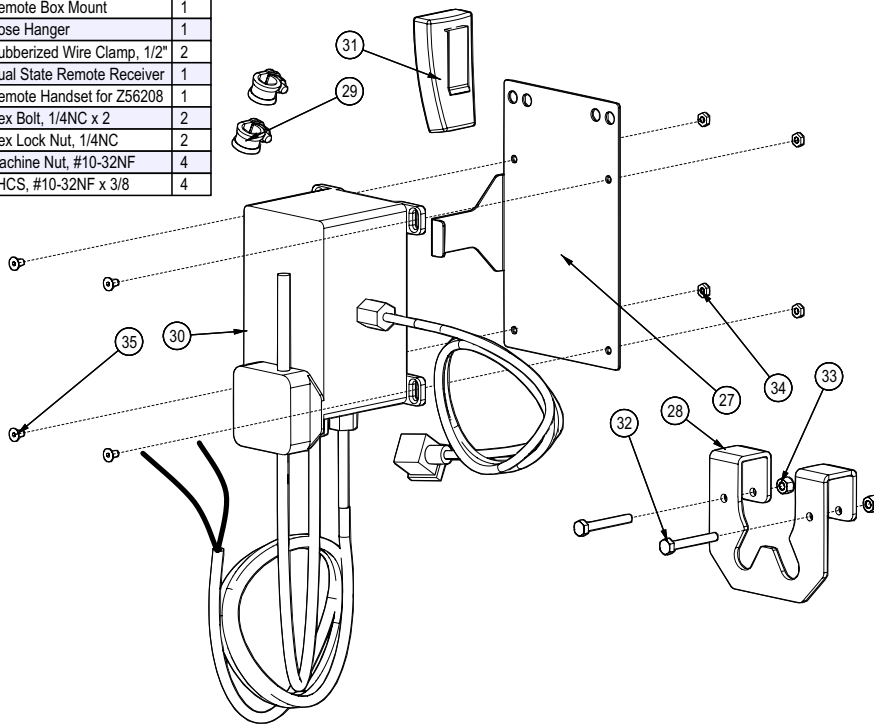

SOLENOID VALVE ASSEMBLY

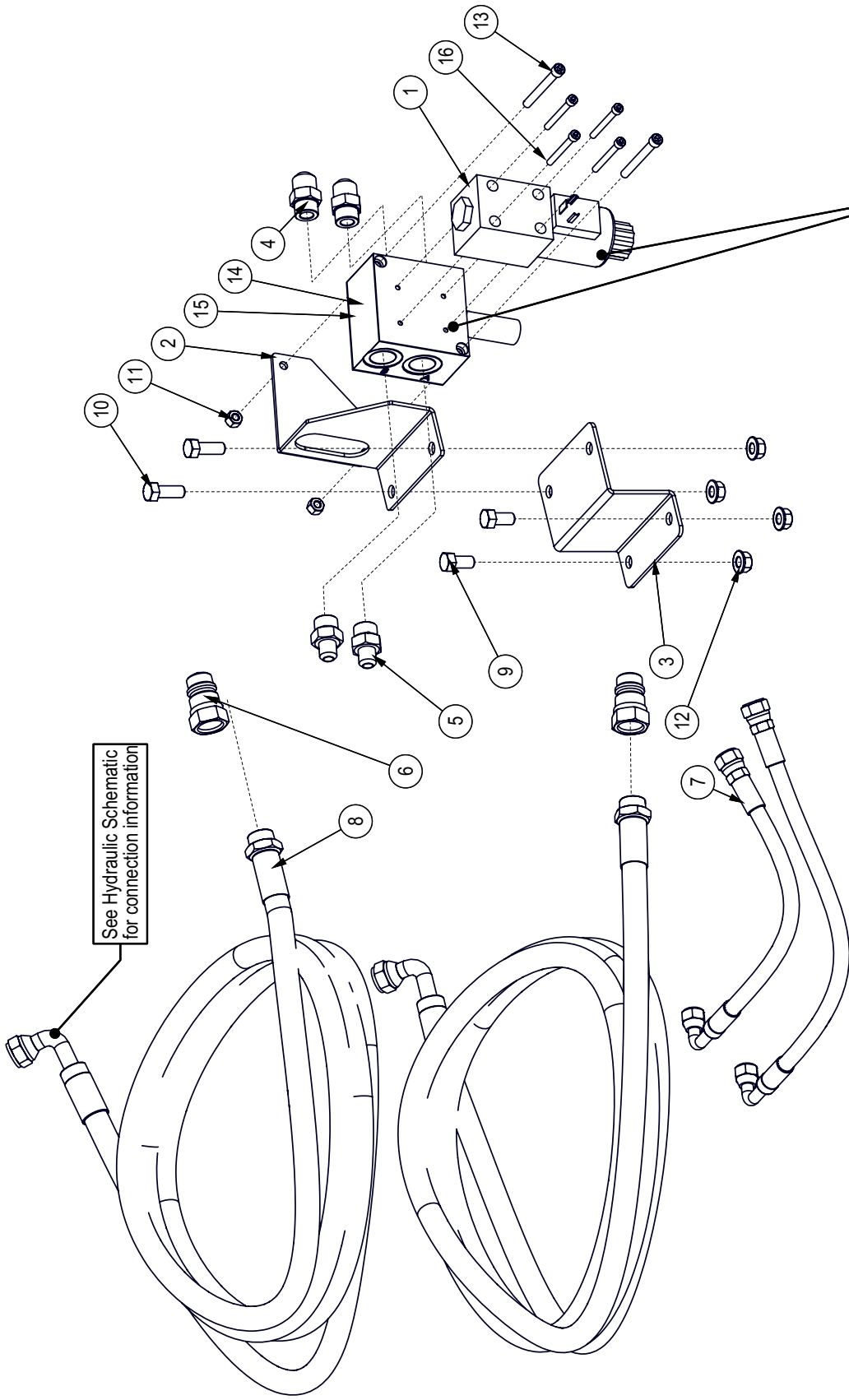

See Hydraulic Schematic for connection information

These components can be purchased as an assembly: #5089A201 Solenoid Valve Assembly

Item	Part Number	Description	Qty
10	Z71310	Hex Bolt, 3/8NC x 1	2
11	Z72211	Hex Lock Nut, 1/4NC	2
12	Z72531	Flange Nut 3/8NC	4
13	Z75117	SHCS, 1/4NC x 2-1/4	2
14	Z56510	SubPlate with Relief	1
15	Z56511	Subplate, Relief x 3000PSI	1
16	Z75102	SHCS, #10-24NC x 1-3/4	4

Item	Part Number	Description	Qty
1	Z56509	Solenoid 4-2 Valve - Motor Spool	1
2	5089L208	Hydraulic Mount Base	1
3	5089L210	Valve Mount Extension	1
4	Z51643	#8ORB x #8JIC	2
5	Z51644	#8ORB x #6JIC	2
6	Z51926	FP08 x Pioneer Coupler	2
7	Z52124	1/4" Hose, FJIC06 x 90 FJIC06 x 26"	2
8	Z52342	1/2" Hose, 90F-JIC08 x MP08 x 60"	2
9	Z71307	Hex Bolt, 3/8NC x 3/4	2

FOR FX205 ONLY

CYLINDER SEAL INSTALLATION

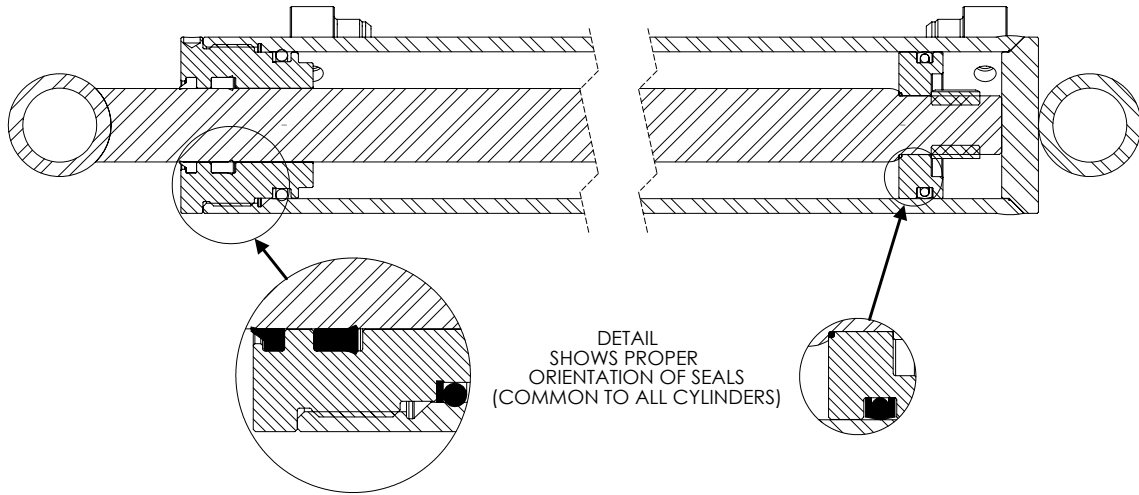

HYDRAULIC CYLINDER DETAIL

Cylinder Seal Kit:
#SLK 1510AN

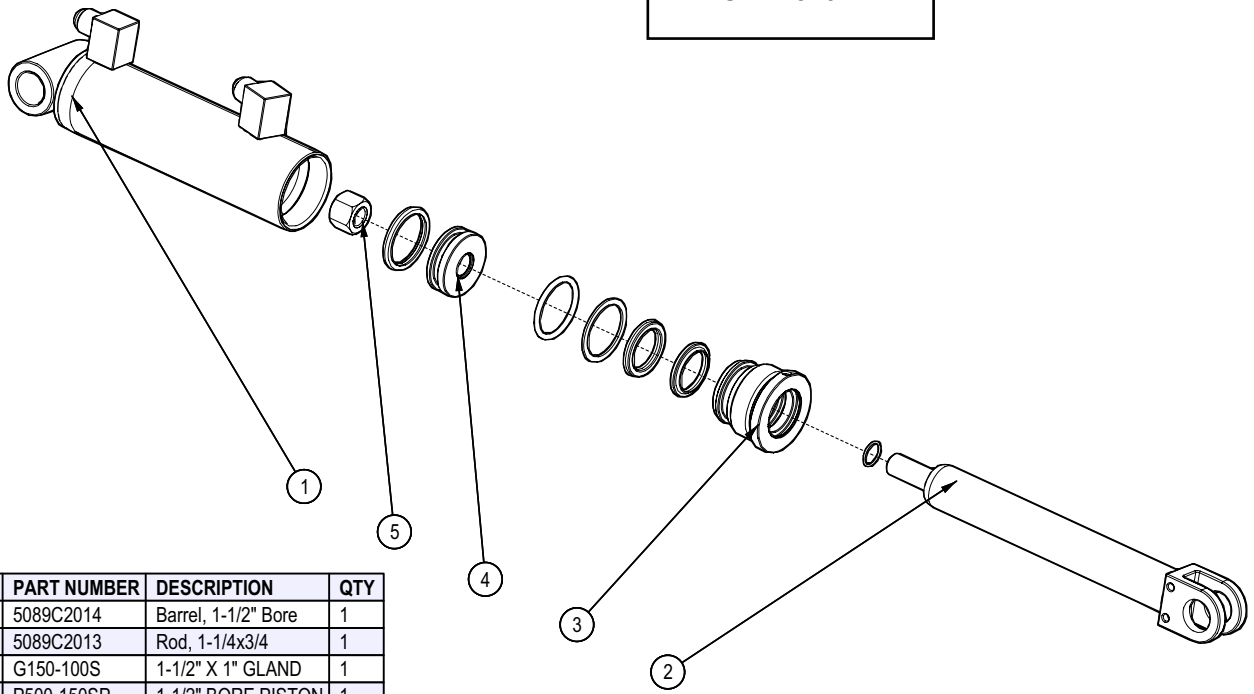

ITEM	PART NUMBER	DESCRIPTION	QTY
1	5089C2014	Barrel, 1-1/2" Bore	1
2	5089C2013	Rod, 1-1/4x3/4	1
3	G150-100S	1-1/2" X 1" GLAND	1
4	P500-150SP	1-1/2" BORE PISTON	1
5	Z72251	Hex Lock Nut, 1/2NC	1