



**WX510 Trailer Log  
Splitter Parts Manual  
S/N 251045 to S/N 251086**



## Foreword

EMB Mfg. has prepared this parts manual to assist customers in ordering quality OEM replacement parts.

Proper and regular service and replacing old, worn or broken parts with the correct Wallenstein parts are essential to prolonging the life of your Wallenstein product. Please refer to this manual before ordering any replacement parts.

All information contained in this parts manual is based on the latest product specification available at the time of printing this manual. If your product differs from the specifications contained within this manual contact EMB Mfg. for information.

EMB reserves the right to alter specifications on their products at any time.

Reproduction of this parts manual of any kind is prohibited without prior written permission from EMB Mfg.

# Table of Contents

Cylinder	4
Main Parts	5
Valve	6
Valve & Fittings	8
Engine & Pump	9
Decal Breakdown	10

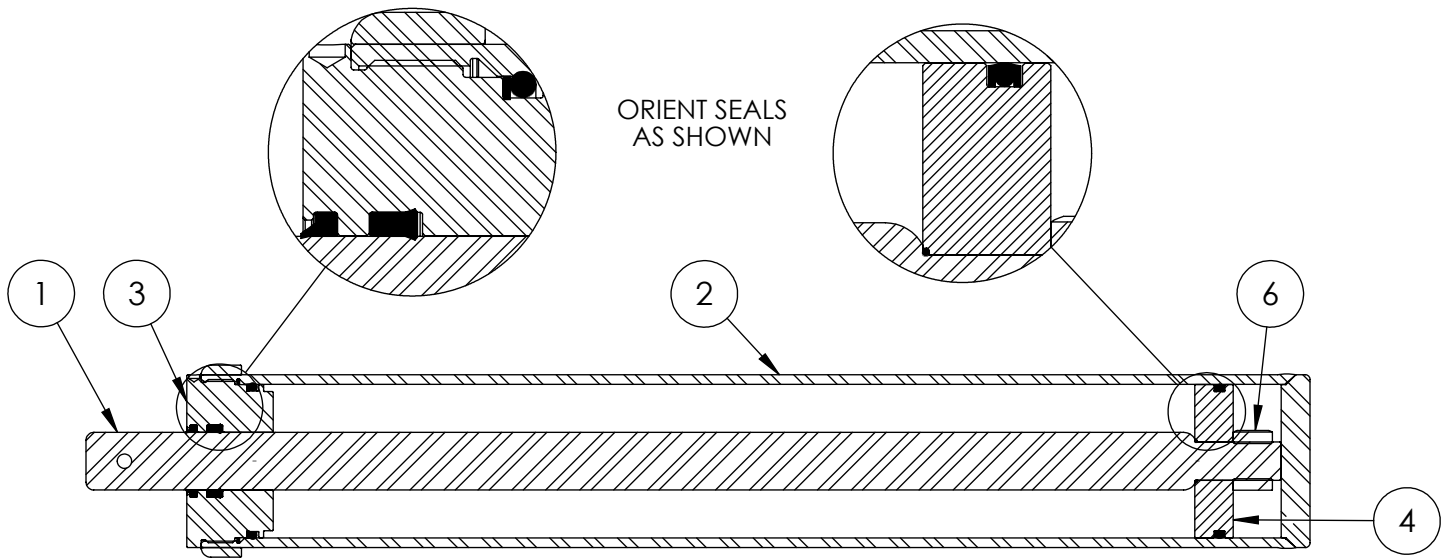

### 4" x 24" STROKE CYLINDER PARTS

ITEM	PART NO.	Description	QTY.
1	2011C1012	Rod, 1-1/2 x 1	1
2	2011C1014	Barrel, 4"	1
3	G400-150SA	4" Bore x 1-1/2" Rod Gland	1
4	P100-400SA	4" Bore Piston	1
5	SLK-4015	Seal Kit, 4 x 1-1/2	1
6	Z72292G8	Hex Lock Nut 1NF Grade 8	1

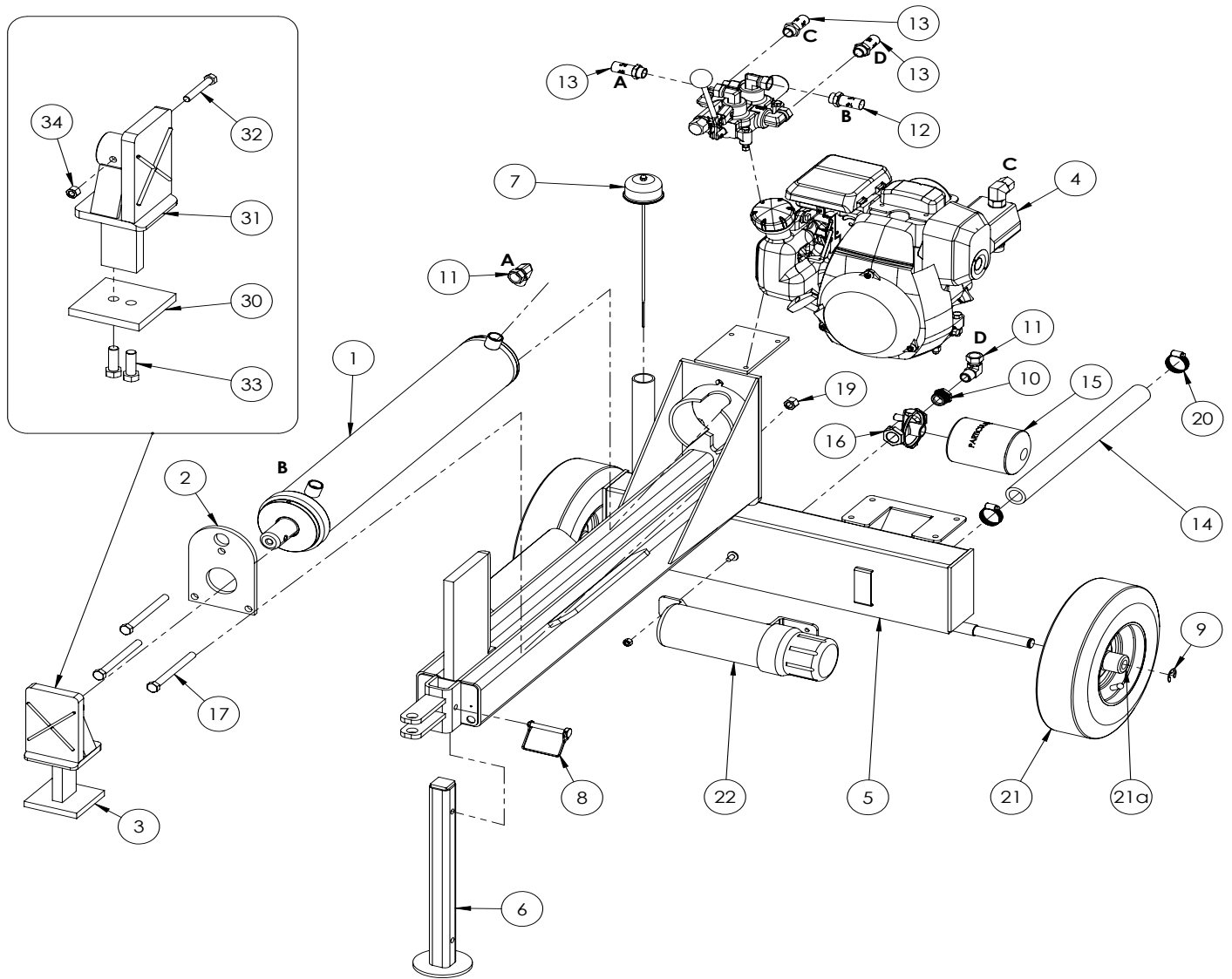

**WX510 PARTS BREAKDOWN**

ITEM	WX510	Description	QTY.
	2011C101	Cylinder, 4 x 24 x 1-1/2	1
	2014S421	Plate, Cylinder Retaining (Bolt)	1
	2051A101	Assembly, Push Block	1
	2051A103	Assembly, Engine to Pump	1
	2051W103	Weldment, WX510 Main Frame	1
	2051W106	Jack Stand, Front	1
	2054A402	Breather cap dipstick	1
	Z12431	Snapper Pin 3/8 x 2-1/4	1
	Z46203	External Retaining Ring, 3/4"	2
	Z51221	Reducer FP x MP 1208	1
	Z51331	Elbow 90 MP x FPX 0808	2
	Z52301	1/2 Hose MP08 x MP08 x 16"	1
	Z52305	1/2 Hose, MP08 x MP08 x 24"	3
	Z52404	Suction Hose, 1" x 18"	1.5
	Z55301	Oil Filter - 3/4 - Particulate	1
	Z55302	Filter Cap, 3/4 x 3/4	1
	Z71555	Hex Bolt 1/2NC x 5-1/2	3
	Z72221	Hex Lock Nut 5/16NC	1
	Z72251	Hex Lock Nut 1/2NC	3
	Z79401	Hose Clamp, #16	2
	Z91311	4.10-6 290# NHS Tire	2
	Z21902	Roller Bearing for Z91311	2
	Z96503	Manual Tube 3-1/2 Short	1
ITEM	PART NO.	Description	QTY.
	2051S117	Cap, Push Block (Bolt)	1
	2051W102	Push Block, Bolted	1
	Z71325	Hex Bolt 3/8NC x 2-1/2	1
	Z71576	Hex Bolt 1/2NF x 1-1/2	2
	Z72231	Hex Lock Nut 3/8NC	1

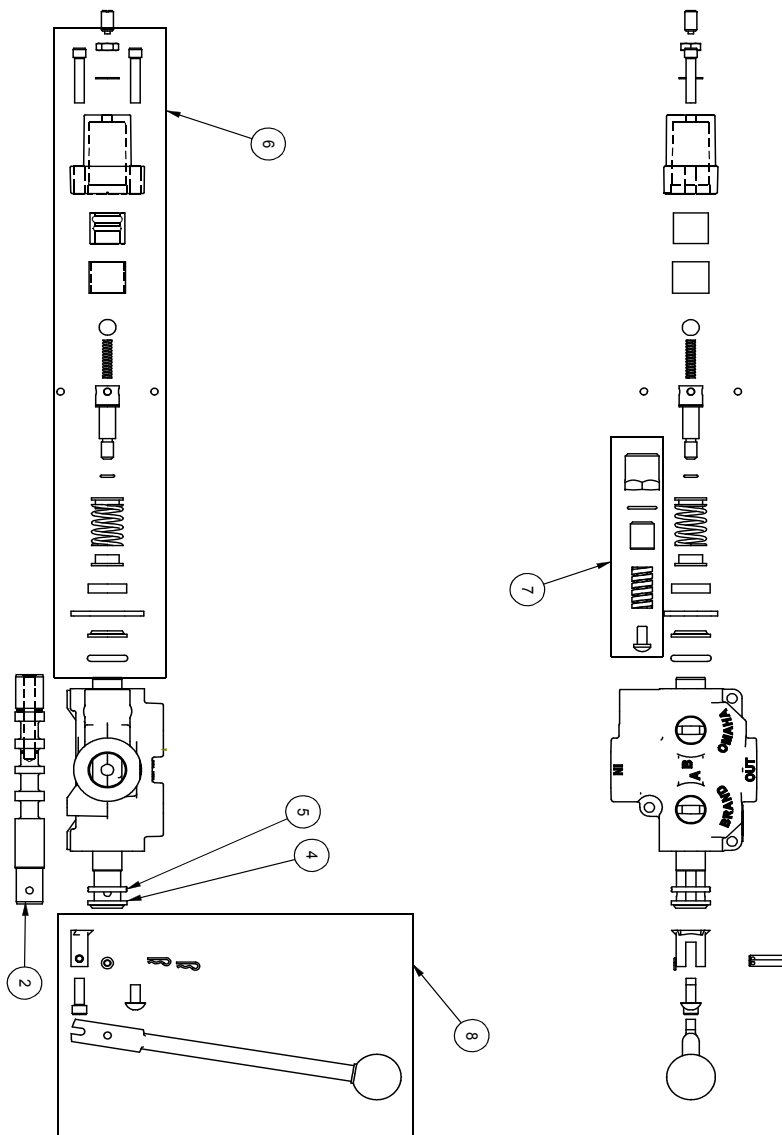

ITEM NO.	QTY.	PART NO.	DESCRIPTION
1	1	AOCAS1B	AO CASTING
2	1	LS304T4J	SPOOL
3	1	P1740	NAME TAG
4	1	SF305	WIPER
5	1	SF304	QUAD RING
6	1	SUB-LS	SUB-LS
		B5057	7/16 BALL
		DC7804	3/16 BALL
		SF306	RETAINER
		SF477L	SH LS ENDCAP
		XDC672	LS SLEEVE
		SF483	SPACER
		SF488	ALLEN SCREW
		SF489	CENTER STOP
		SF490	CENTERING SPRING
		SF492	HOUSING
		SF315	SPACER
		LS305	DETENT SPRING
		DC7383	O-RING 3-902
		SF498	O-RING, BLUE, METRIC
		LS306	LS WIPER
		SF502	5/16 LOCK WASHER
		SF503	PLUNGER, SPRING
		SF504	5/16 HEX JAM NUT
		SUB-R	RELIEF
		P1603	CAP NUT
		SF322	O-RING 2-016
		SF364A	ADJ. SCREW
		B505	SPRING
		SF361A	POPPET
		Z56915	HANDLE KIT
		SF377	RETAINER
		SF376	SEAL RETAINER
		SF367A	CLEVIS
		SF388	HANDLE
		SF389	PIN
		P1767	PIN CLIP
		HP5	MACH. SCREW
		SF311	KNOB
		SF308	CAP SCREW
		SF303T4J	SPOOL
		P1654	WARNING TAG

ITEM NO.	QTY.	PART NO.	DESCRIPTION
1	1	B5057	7/16 BALL
2	4	DC7604	3/16 BALL
3	1	SF306	RETAINER
4	1	SF477L	SH LS ENDCAP
5	1	SF480	SD SLEEVE
6	1	SF483	SPACER
7	2	SF486	ALLEN SCREW
8	2	SF489	CENTER STOP
9	1	SF490	CENTERING SPRING
10	1	SF492	HOUSING
11	1	SF315	SPACER
12	1	LS305	DETENT SPRING
13	1	DC7583	O-RING 3-902
14	1	SF496	METRIC O-RING
15	1	LS306	LS WIPER
16	1	SF502	5/16 LOCK WASHER
17	1	SF503	SPRING PLUNGER
18	1	SF504	5/16 HEX JAM NUT

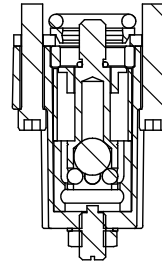
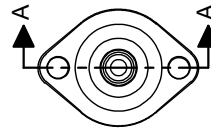
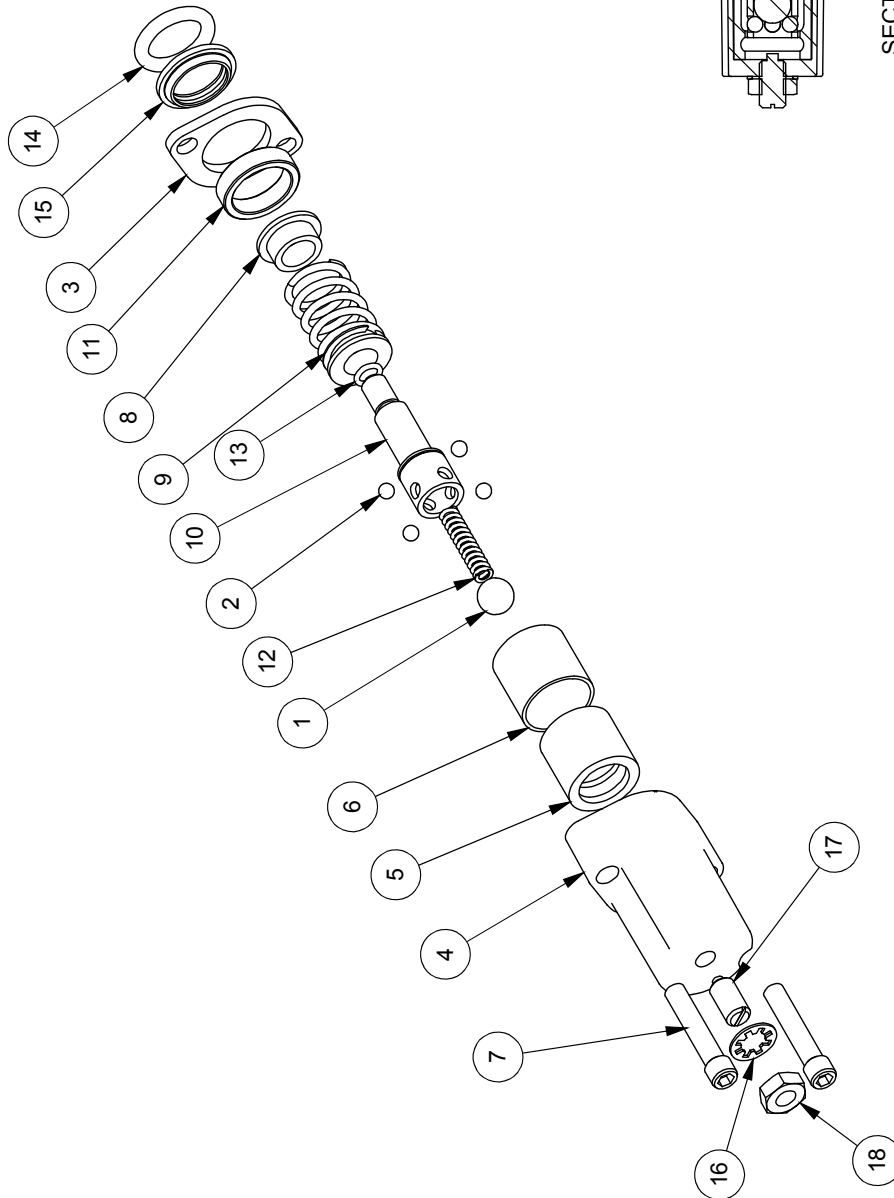

SECTION A-A

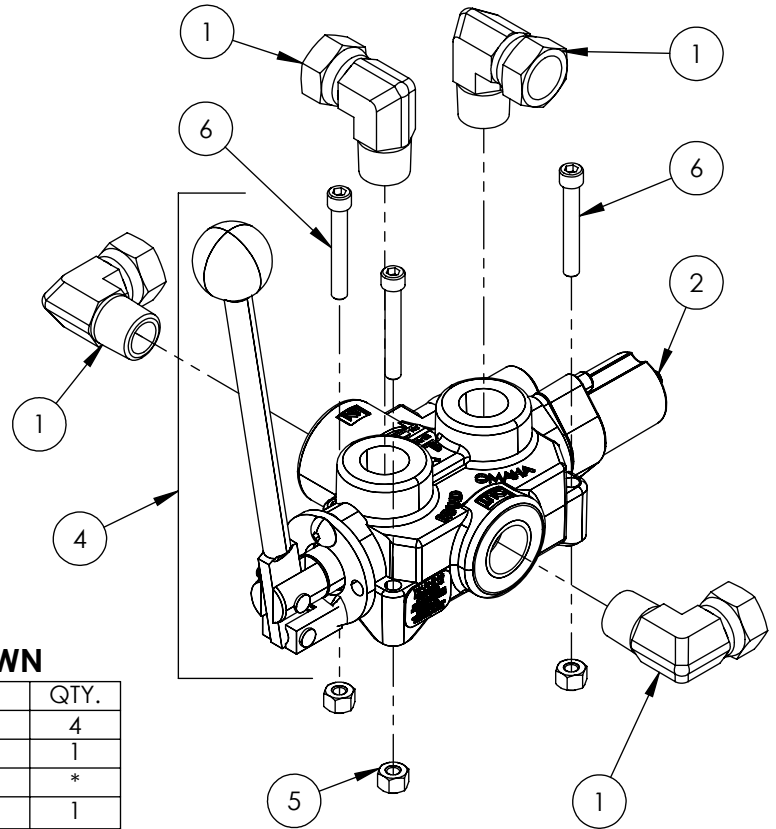

**VALVE AND FITTINGS PARTS BREAKDOWN**

ITEM	PART NO.	Description	QTY.
1	Z51331	Elbow 90 MP x FPX 0808	4
2	Z56209	Valve, Single Function Detent	1
3	*Z56210*	Valve, Closed Center	*
4	Z56915	Complete Handle Kit for Z56209	1
5	Z72111	Hex Lock Nut 1/4NC	3
6	Z75114	SHCS, 1/4NC x 1-3/4	3

\*CLOSED CENTER VALVE REQUIRED FOR "C" MODELS.\*



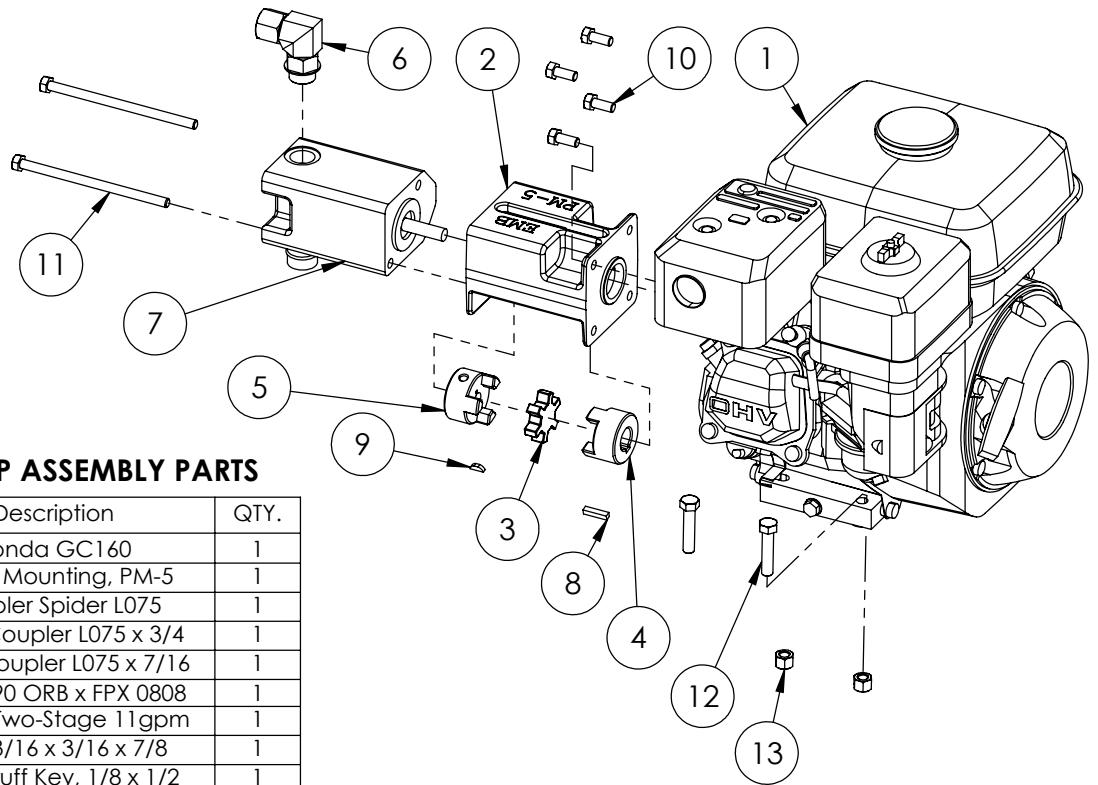

**5hp ENGINE / PUMP ASSEMBLY PARTS**

ITEM	2051A103	Description	QTY.
1	Z47306	Honda GC160	1
2	Z53801	Pump Mounting, PM-5	1
3	Z46408	Coupler Spider L075	1
4	Z46406	Shaft Coupler L075 x 3/4	1
5	Z46407	Shaft Coupler L075 x 7/16	1
6	Z51383	Elbow 90 ORB x FPX 0808	1
7	Z53201	Pump, Two-Stage 11gpm	1
8	Z46521	Key, 3/16 x 3/16 x 7/8	1
9	Z46592	Woodruff Key, 1/8 x 1/2	1
10	Z71273	Hex Bolt, 5/16NF x 3/4	4
11	Z71255	Hex Bolt, 5/16NC x 5-1/2	2
12	Z71215	Hex Bolt, 5/16NC x 1-1/2	4
13	Z72221	Hex Lock Nut 5/16NC	4

## HORIZONTAL LOG SPLITTER DECAL BREAKDOWN

ITEM	PART NO.	DESCRIPTION	QTY
1	Z94039	CAUTION - Read Manual	1
2	Z94040	WARNING - Moving Wedge	2
3	Z94067	Clear Guide	2
4	Z94056	Wallenstein	2
5	Z94019	Made in Canada	3
6	Z94066	Apply Oil or Grease	1

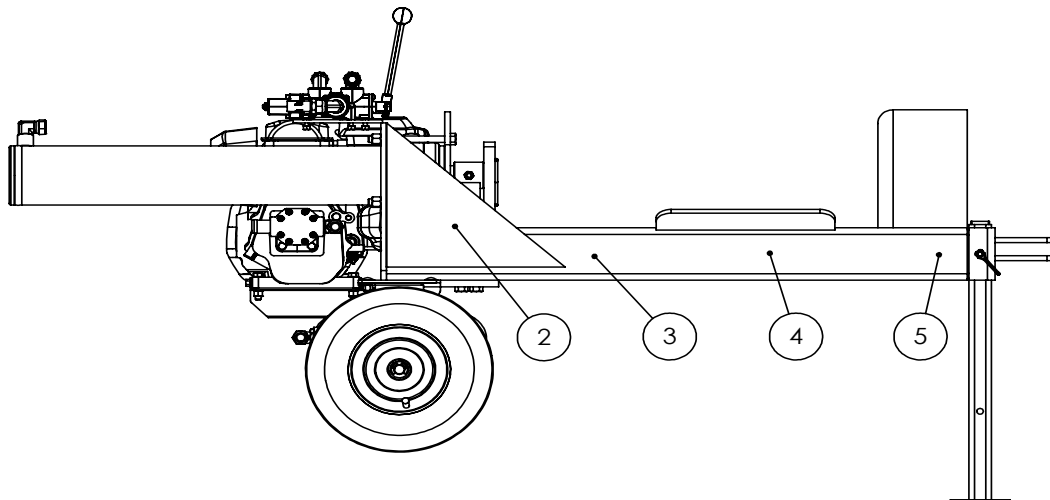
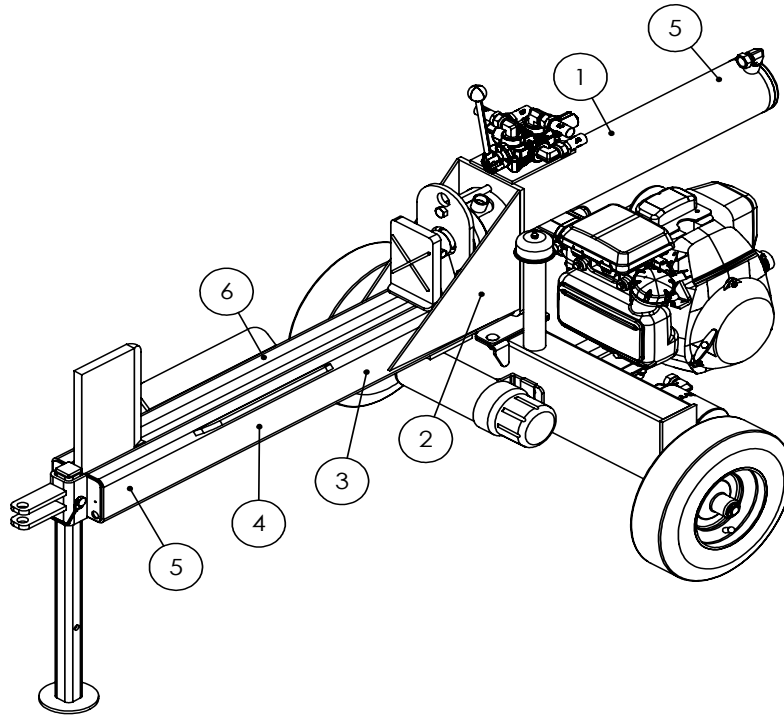

# Trailer Splitter Decals

Z94056



Z94067



Z94019



Z94066



Z94039

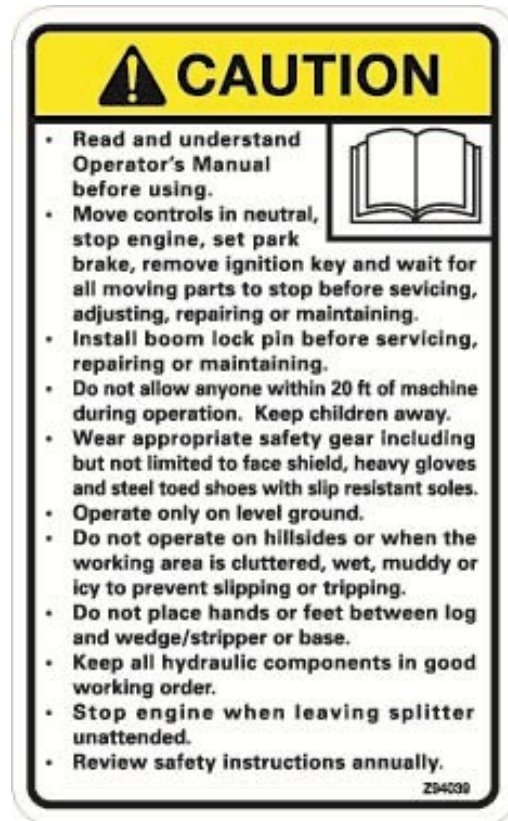

Z94040





**WALLENSTEIN Products Manufactured by:**

**EMB MFG Inc.**

4144 Boomer Line  
St. Clements, Ontario  
Canada N0B 2M0  
Phone: 1-877-695-9283  
Fax: 519-699-4146  
[www.embmfg.com](http://www.embmfg.com)