



BX92R Chipper Parts Manual

S/N 192R78 & After



Foreword

EMB Mfg. has prepared this parts manual to assist customers in ordering quality OEM replacement parts.

Proper and regular service and replacing old, worn or broken parts with the correct OEM parts are essential to prolonging the life of your EMB product. Please refer to this manual before ordering any replacement parts.

All information contained in this parts manual is based on the latest product specification available at the time of printing this manual. If your product differs from the specifications contained within this manual contact EMB Mfg. for information.

EMB reserves the right to alter specifications on their products at any time.

Reproduction of this parts manual of any kind is prohibited without prior written permission from EMB Mfg.

Table of Contents

Main Parts	4
Discharge Chute	5
Roller Feed Chute	6
Z56209 Control Valve Seal Kit	8
Z56305 Flow Valve Seal Kit	8
Binacchi PTO	9
Decal Breakdown	11

BX92R Main Parts Breakdown

ITEM	PART NO.	DESCRIPTION	QTY
1	1012A201	Assembly, Discharge Chute	1
2	1012L206	PTO Cover Mounting Bracket	1
3	1012L212	PTO Cover	1
4	1012W204	Twig Breaker	1
5	1019M903	Knife, BX92 Rotor	4
6	1019M904	Knife, BX92 Ledger	1
7	1019W901	Housing, Bottom Rotor	1
8	1019W902	Housing, Upper Rotor	1
9	1019W903	Rotor, BX92 2-Knife	1
10	1020 920R	10-1/2" Hydraulic Roller Feed Chute	1
11	1020W006	Lift Assist Bracket	1
12	Z11441	Implement Pin 1-1/8 x 6-5/16	2
13	Z12110	Latch Pin 3/16	3
14	Z25203	4-Bolt Bearing 2" Bore	2
15	Z29202	Grease Zerk 1/4NF	2
16	Z34201	Gas Spring 7/8x11	2
17	Z44802	Global Series 8 PTO Shaft 2" Crossbolt	1
18	Z46563	Key, 1/2 x 1/2 x 3	1
19	Z71210	Hex Bolt 5/16NC x 1	2
20	Z71230	Hex Bolt 5/16NC x 3	2
21	Z71307	Hex Bolt 3/8NC x 3/4	2
22	Z71512	Hex Bolt 1/2NC x 1-1/4	7
23	Z71572G8	Hex Bolt 1/2NF x 7/8 Gr8	16
24	Z71612	Hex Bolt 5/8NC x 1-1/4	5
25	Z71671	Hex Bolt 5/8NF x 1-1/2	3
26	Z72221	Hex Lock Nut 5/16NC	2
27	Z72231	Hex Lock Nut 3/8NC	2
28	Z72251	Hex Lock Nut 1/2NC	6
29	Z72282	Hex Lock Nut 7/8NF	2
30	Z72531	Flange Nut 3/8NC	2
31	Z73380	Spring Washer 7/8	2
32	Z74132	Set Screw 3/8NF	4
33	Z78301	Machine Screw 1/4NC x 3/4	2

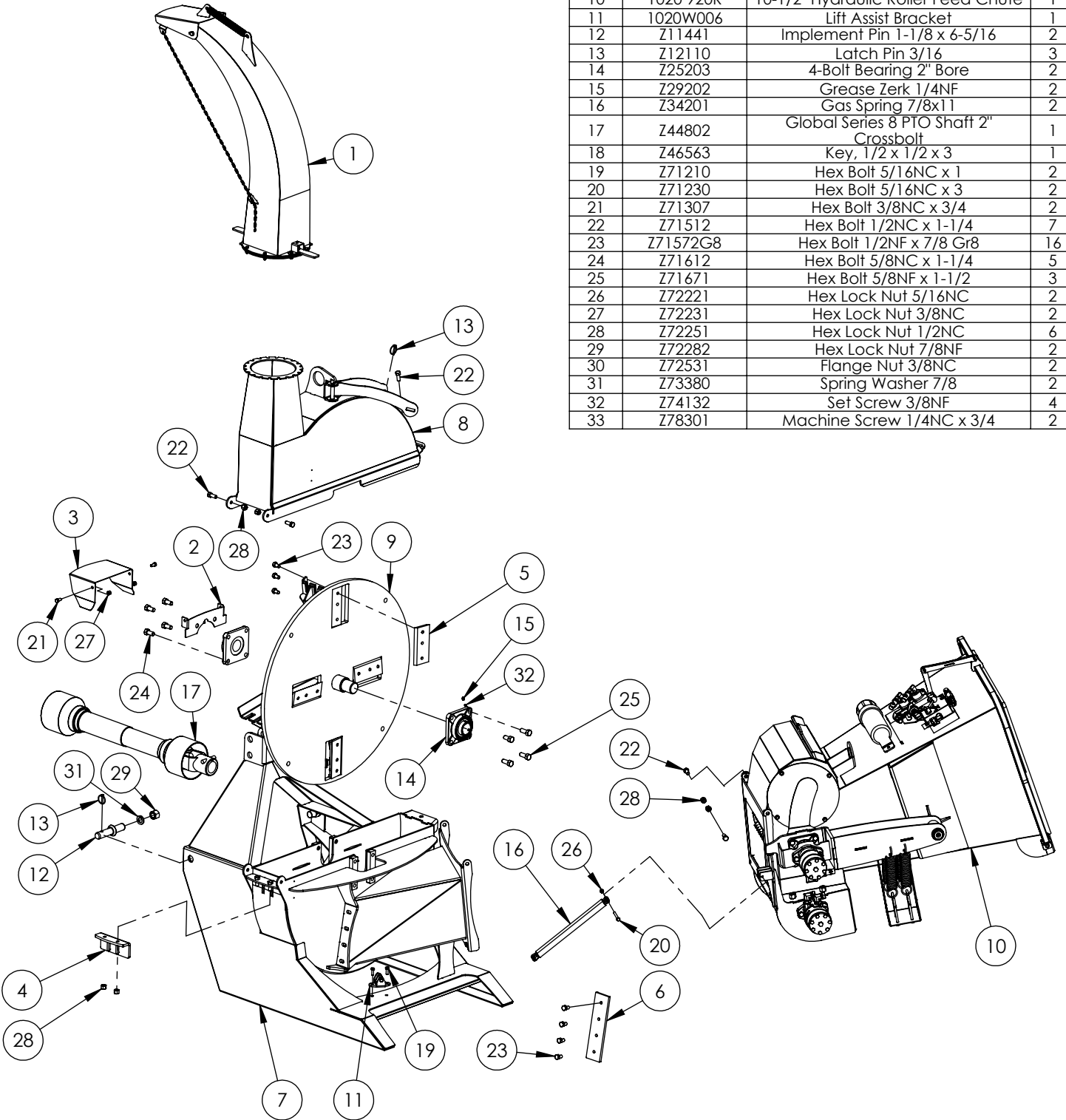

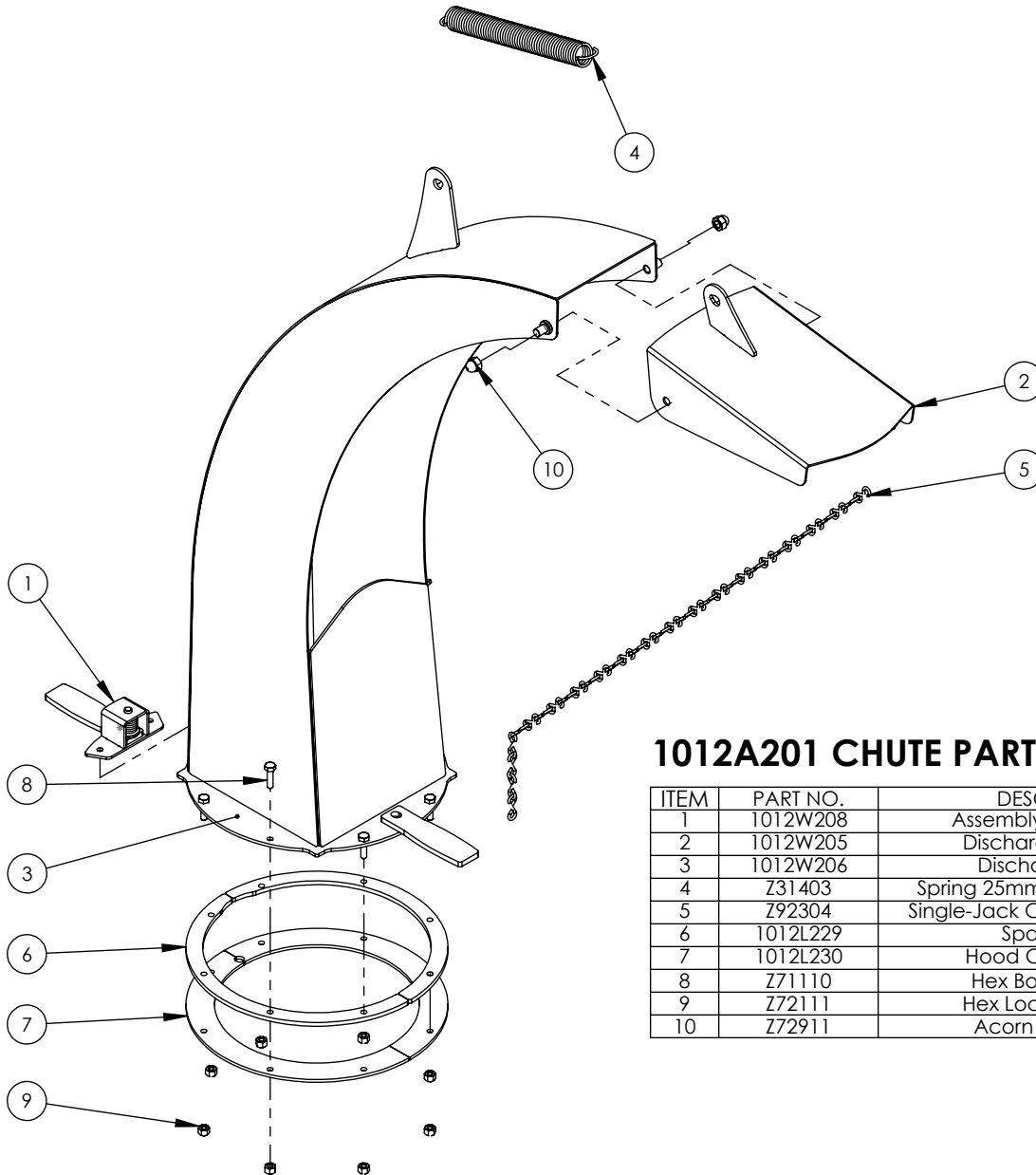

1012A201 CHUTE PARTS BREAKDOWN

ITEM	PART NO.	DESCRIPTION	QTY
1	1012W208	Assembly, Hood Latch	1
2	1012W205	Discharge Deflector	1
3	1012W206	Discharge Chute	1
4	Z31403	Spring 25mm x 178mm Heavy	1
5	Z92304	Single-Jack Chain #10 [35 links]	3.2
6	1012L229	Spacer Ring	2
7	1012L230	Hood Capture Ring	2
8	Z71110	Hex Bolt 1/4NC x 1	8
9	Z72111	Hex Lock Nut 1/4NC	8
10	Z72911	Acorn Nut, 3/8NC	2

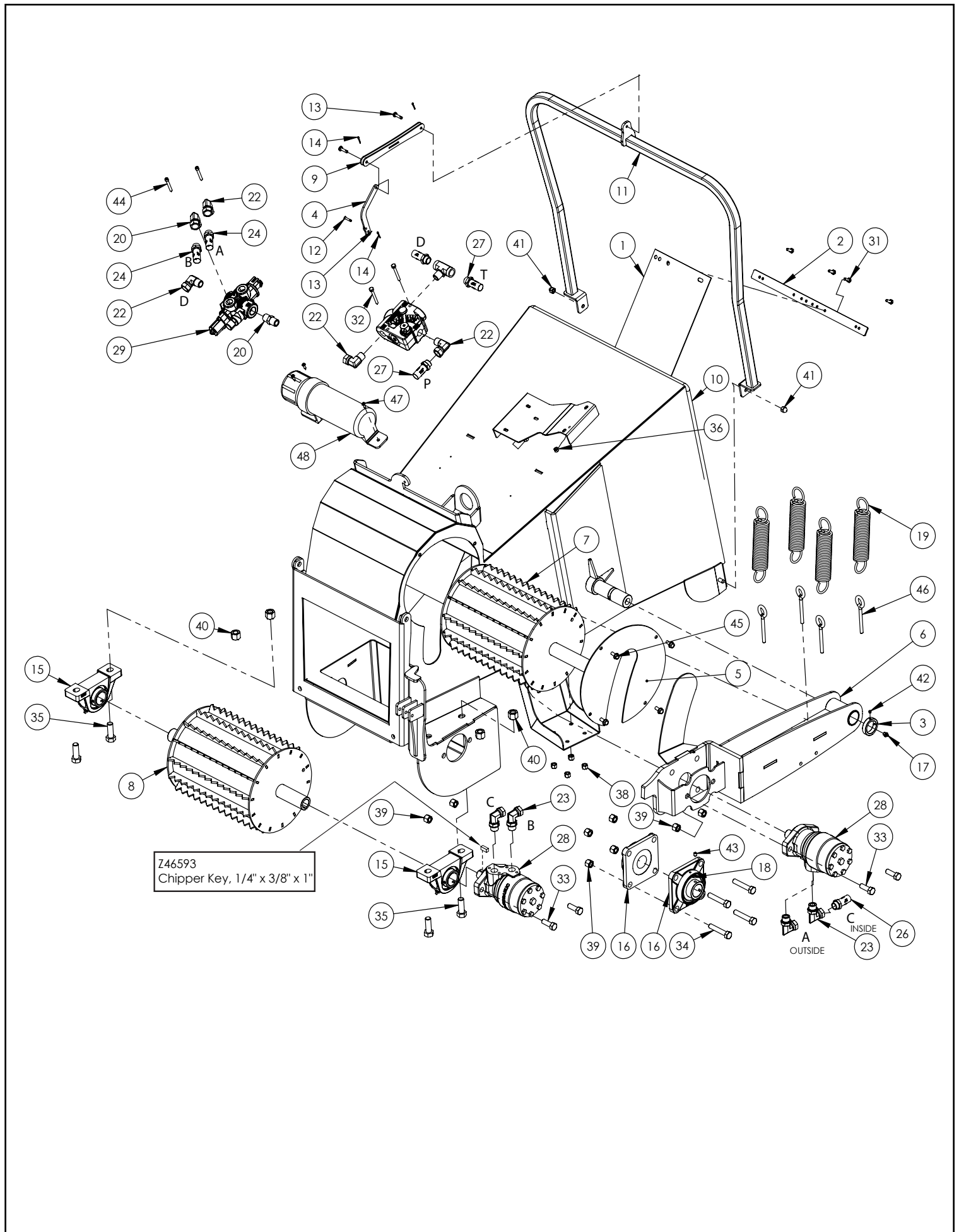

920R PARTS BREAKDOWN

ITEM	PART NO.	Description	QTY.
1	1011S103	Flap, Hopper	2
2	1012L251	Strap, Hopper Flap	1
3	1013M025	Arm Capture Bushing	1
4	1020L417	BX92R Roller Arm Link	1
5	1020L505	Cover, Roller Access	1
6	1020W002	Arm, Upper Roller	1
7	1020W003	Roller, Upper Feed	1
8	1020W004	Roller, Lower Feed	1
9	1020W007	Valve Link	1
10	1020W008	Hopper, Roller Feed	1
11	1020W405	Handle, Feed Regulating	1
12	Z11302	Clevis Pin 3/16 x 3/4	1
13	Z11313	Clevis Pin 1/4 x 3/4	3
14	Z12301	Cotter Pin 3/32 X 3/4	4
15	Z24101	P208 Pillow Block 1-1/2	2
16	Z25204	4-Bolt Bearing 1-1/2" Bore	2
17	Z29201	Grease Fitting, 1/8NPT	1
18	Z29202	Grease Zerk 1/4NF	2
19	Z31502	Spring, 1-3/4 x 9 Heavy	4
20	Z51122	Nipple, MP x MP 0808	1
21	Z51161	Tee, FP x FP x MP 080808	1
22	Z51331	Elbow 90 MP x FPX 0808	5
23	Z51384	#10ORB x 1/2FNPT 90 Elbow	4
24	Z52310	1/2 Hose MP08 x MP08 x 48"	2
25	Z52314	1/2 Hose, MP08 x MP08 x 10"	1
26	Z52317	1/2 Hose, 1/2MP x 1/2MP x 20"	1
27	Z52318	1/2 Hose, 1/2MP x 1/2MP x 130"	2
28	Z54104	300 Series Hydraulic Motor	2
29	Z56209	Ctrl Valve, Single w/ Defent	1
30	Z56305	Brand PFC 0-8 GPM	1
31	Z71107	Hex Bolt 1/4NC x 3/4	4
32	Z71122	Hex Bolt 1/4NC x 2-1/4	2
33	Z71515	Hex Bolt 1/2NC x 1-1/2	4
34	Z71527	Hex Bolt, 1/2NC x 2-3/4	4
35	Z71617	Hex Bolt 5/8NC x 1-3/4	4
36	Z72111	Hex Lock Nut 1/4NC	2
37	Z72221	Hex Lock Nut 5/16NC	3
38	Z72231	Hex Lock Nut 3/8NC	4
39	Z72251	Hex Lock Nut 1/2NC	8
40	Z72261	Hex Lock Nut 5/8NC	4
41	Z72911	Acorn Nut, 3/8NC	2
42	Z74110	Set Screw 1/4NC	2
43	Z74121	Set Screw 5/16NC	4
44	Z75114	SHCS, 1/4NC x 1-3/4	3
45	Z76121	Flange Bolt 5/16NC x 3/4	4
46	Z76531	Eye Bolt 3/8NC x 3-1/2	4
47	Z76712	Self-tapping Screw #10	3
48	Z96503	Manual Tube 3-1/2 Short	1

Z56209 Control Valve Seal Kit

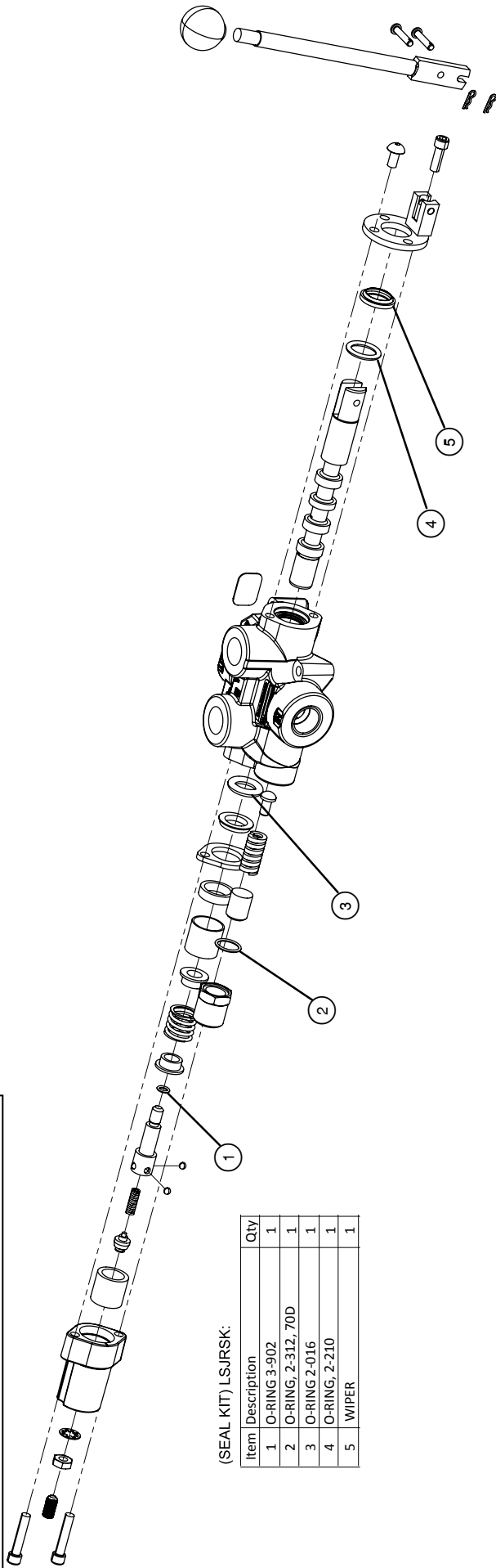

(SEAL KIT) LSJRSK:

Item	Description	Qty
1	O-RING 3-902	1
2	O-RING, 2-312, 70D	1
3	O-RING 2-016	1
4	O-RING, 2-210	1
5	WIPER	1

Item	Description	Qty
1	SEAL RETAINER	2
2	2 B5024 ORING, 2116	2
3	2 P1659 ORING, 2019	2
4	ORING, 3912	2
Legacy Items Incl. In Kit But Not Shown		
	P1737 ORING, 2021	2
	ORING, 2020	2

Z56305 Flow Valve Seal Kit

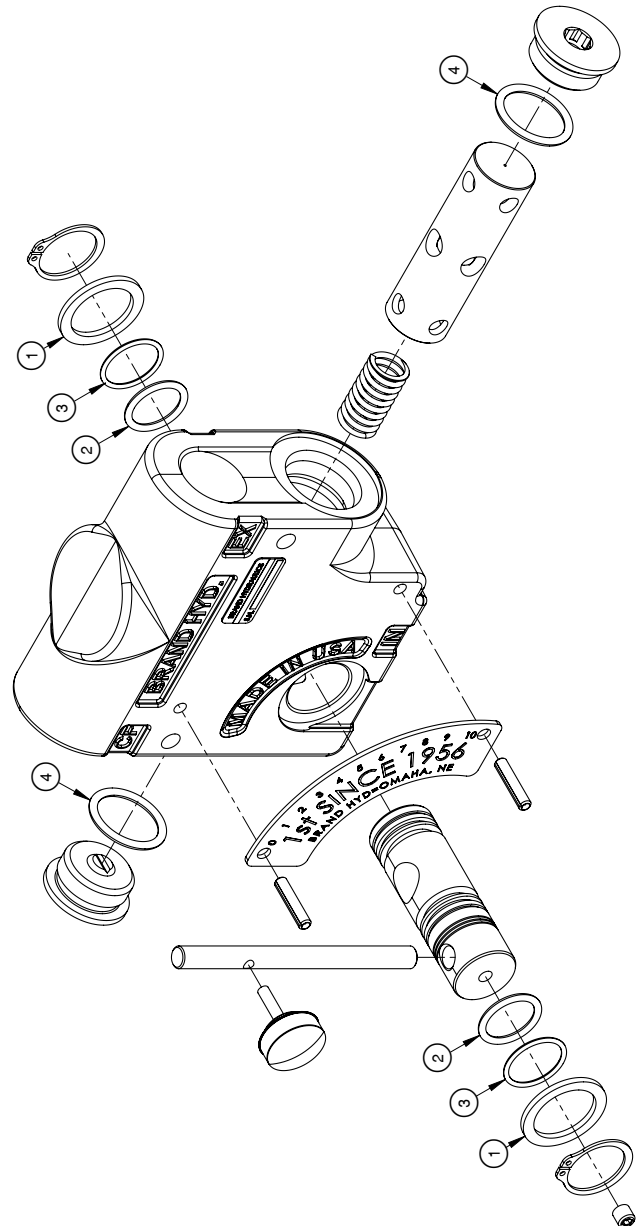

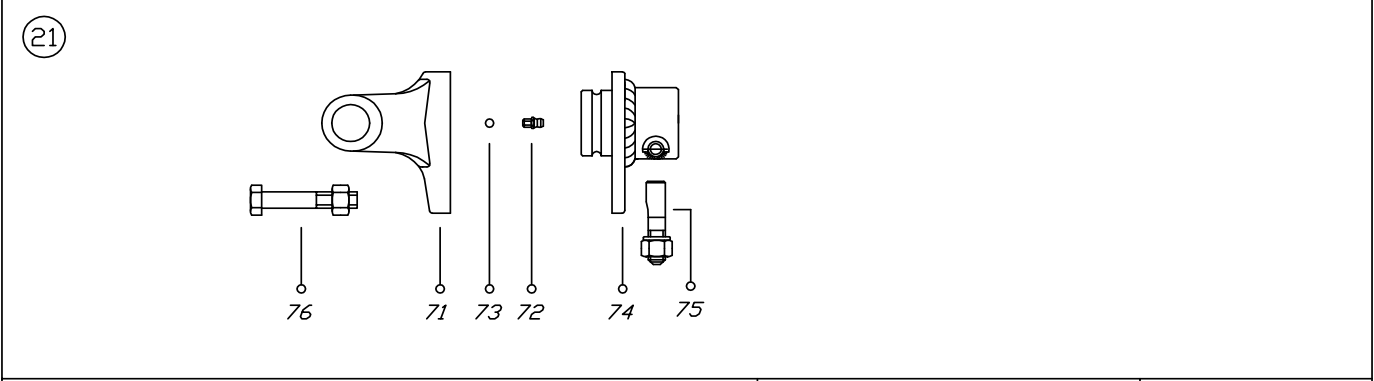
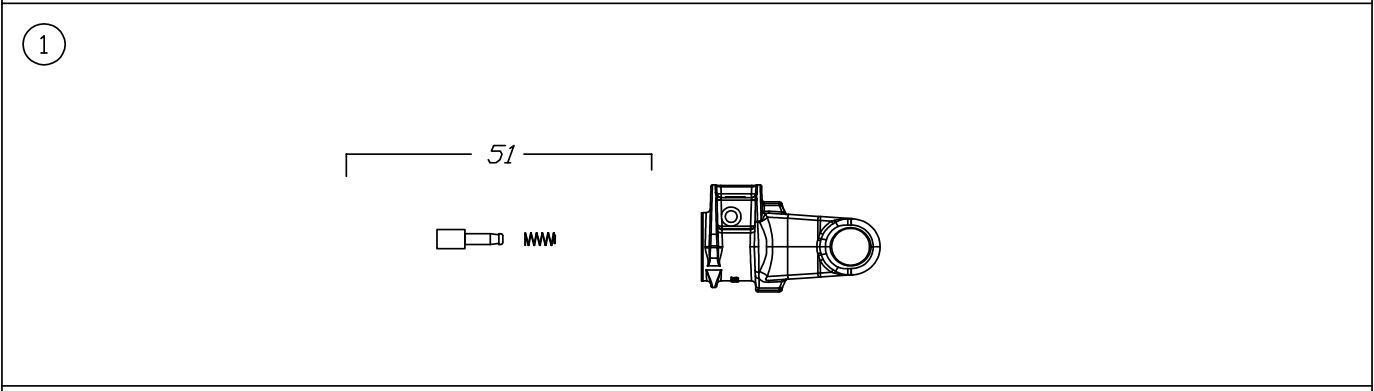
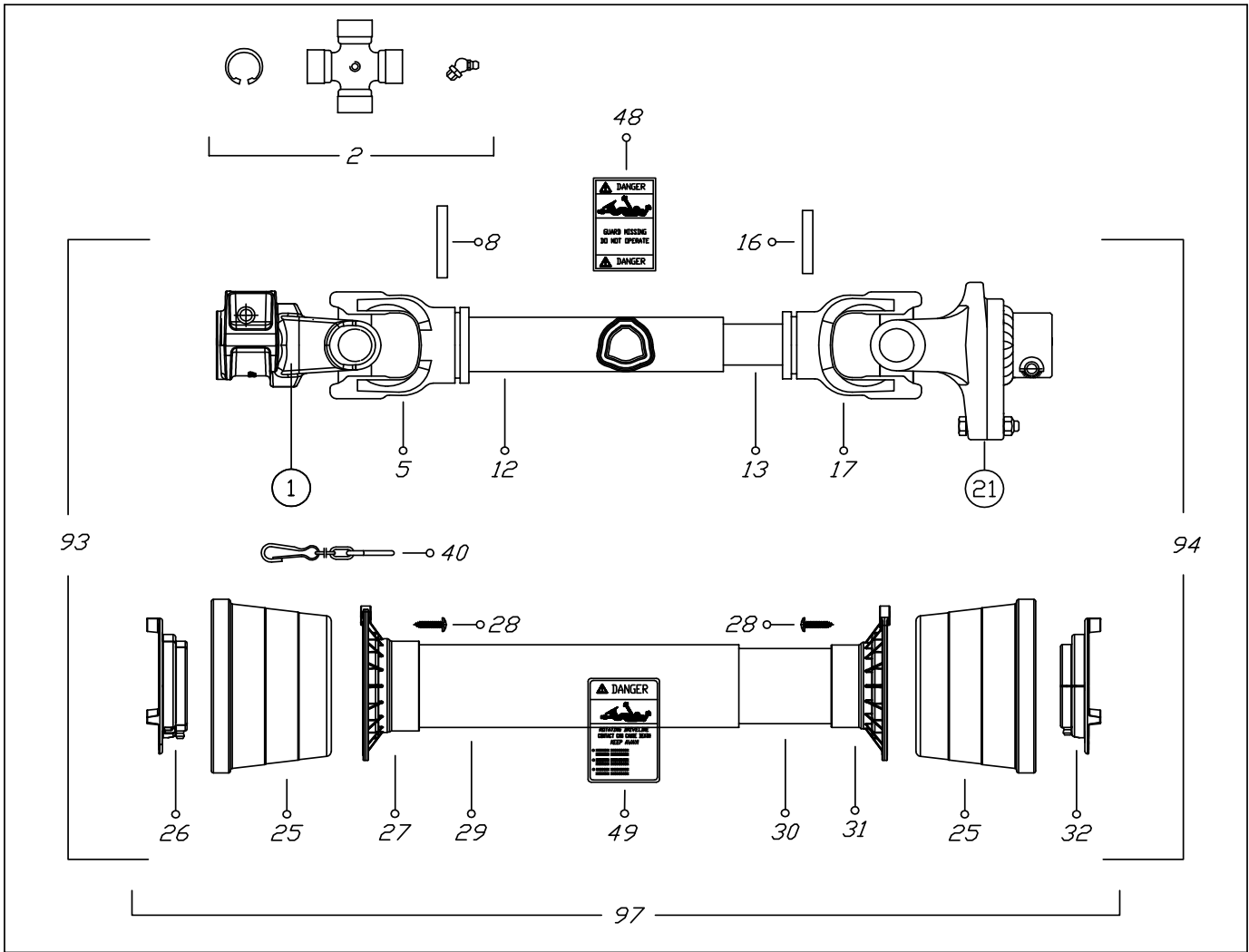

VIETATE LE RIPRODUZIONI NON AUTORIZZATE NOT PERMITTED AL RIGHTS RESERVED	TOUTE REPRODUCTION NON AUTORISEE EST INTERDITE NICHT GENEHMIGTE VERVIELFAELTUNGEN SIND UNZULASSIG	CODICE C.E.D. B8D061US098001	DATA 29/01/10
---	--	--	-------------------------

SPARE PARTS LIST : B8D061US098001

POS.	DESCRIPTION	Q.	RIF. BINACCHI
01	YOKE	1	0800803A60
02	CROSS JOURNAL ASS.	2	08208
05	OUTER TUBE YOKE	1	08080021
08	FLEXIBLE PIN	1	098701075
12	CM. 100 CARDAN TUBE(*)	1	09881544100
13	CM. 100 CARDAN TUBE(*)	1	09881455100
16	FLEXIBLE PIN	1	098701065
17	INNER TUBE YOKE	1	08080011
21	SHEAR BOLT	1	08808P70
25	CONE SHIELD BELL 07-08	2	021908C001
26	OUTER BEARING	1	025508C001
27	OUTER BASE CONE 07-08	1	025408C001
28	SCREW	8	0998052242
29	OUTER SAFETY TUBE	1	0988981NB8066
30	INNER SAFETY TUBE	1	0988975NB8066
31	INNER BASE CONE 07-08	1	025408C002
32	INNER BEARING	1	025508C002
40	CHAIN	1	0252000001
48	LABEL DANGER OUTER DRIVE TUBE	1	09872006
49	EXTERNAL SHIELD LABEL	1	09872003
51	COMPLETE PUSH BUTTTON	1	0986014060
71	YOKE FOR LB8	1	088608553
72	GREASE NIPPLE	1	0984010150
73	STEEL BALL	24	098680516
74	HUB	1	08868P70
75	CONIC SCREW	1	0408000061
76	NUT AND BOLT M12 x 65	1	Z19408
93	OUTER HALF SHAFT	1	B8061US2
94	INNER HALF SHAFT	1	B8061US1098001
97	SAFETY GUARD	1	083US08061

BX92R DECAL BREAKDOWN

ITEM	PART NO.	DESCRIPTION	QTY
1	Z94056	WALLENSTEIN Decal	2
2	Z94019	1" Dia. Made In Canada	5
3	Z94072	BX92R	2
4	Z94007	DANGER - Rotating Blades	3
5	Z94006	CAUTION - Read Manual	1
6	Z94009	DANGER - Rotating Driveline Hazard	1
7	Z94008	DANGER - Thrown Object Hazard	3
8	Z94015	Reverse, Neutral, Feed - RH	1
9	Z94014	Reverse, Neutral, Feed - LH	1
10	Z94005	High Pressure	2

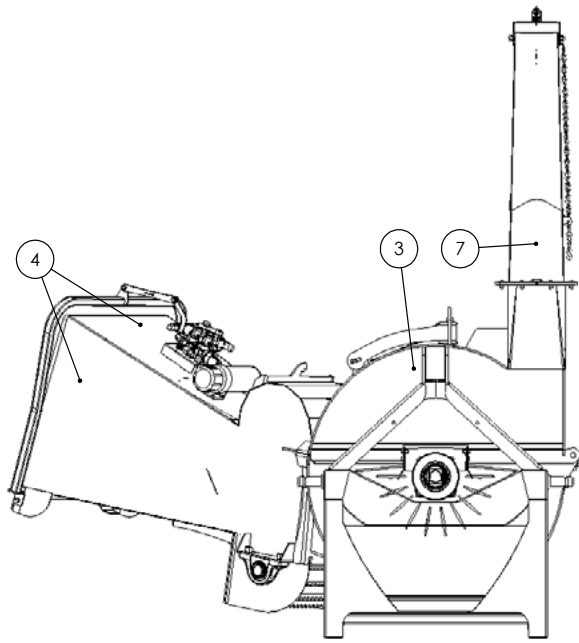

FRONT

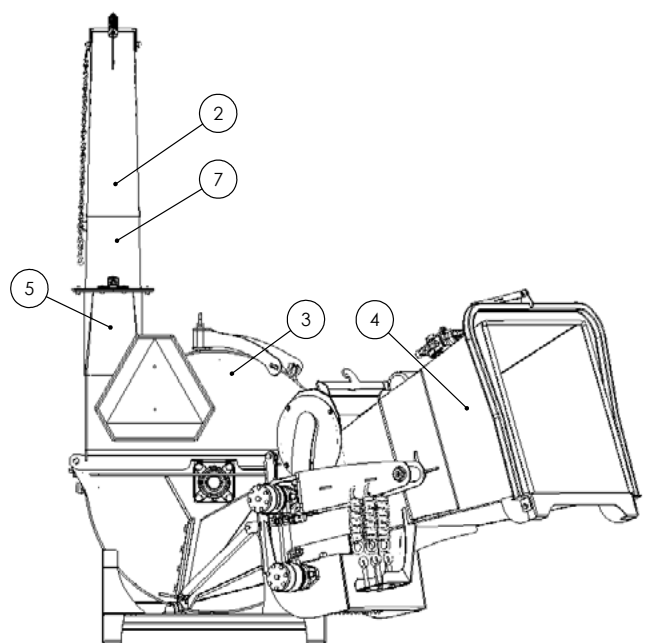

BACK

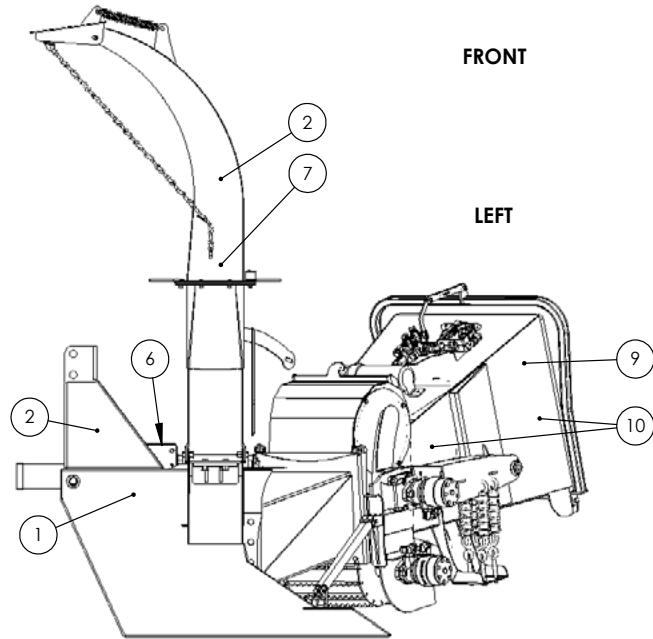

LEFT

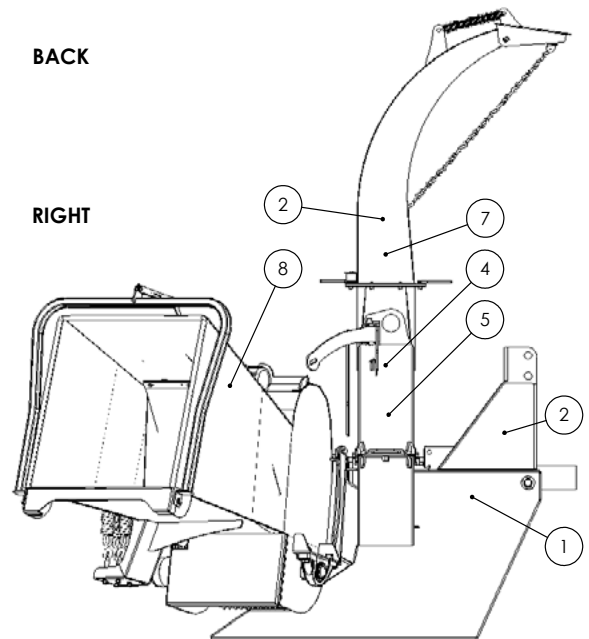

RIGHT

Decals BX92R

Z94056



Z94072



Z94007



Z94019



Z94006

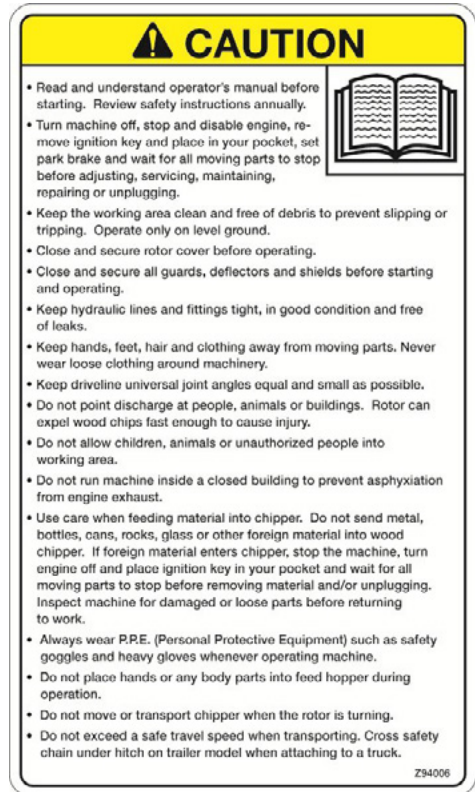

Z94009



Z94015

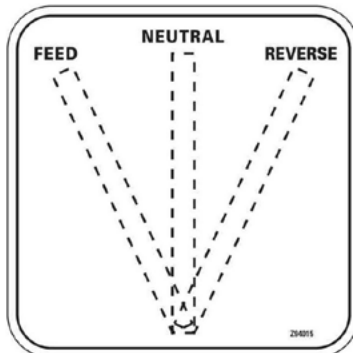

Z94014

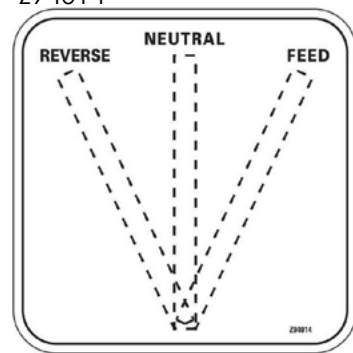

Z94008



Z94005



TWO PANEL BX92R DECAL BREAKDOWN

ITEM	PART NO.	DESCRIPTION	QTY
1	Z94056	WALLENSTEIN Decal	2
2	Z94019	1" Dia. Made In Canada	5
3	Z94072	BX92R	2
4	Z94120	DANGER - Rotating Blades	3
5	Z94119	CAUTION - Read Manual	1
6	Z94118	DANGER - Rotating Driveline Hazard	1
7	Z94117	DANGER - Thrown Object Hazard	3
8	Z94602	Reflector	1
9	Z94015	Reverse, Neutral, Feed - RH	1
10	Z94014	Reverse, Neutral, Feed - LH	1
11	Z94167	High Pressure	2
12	Z94143	121 dB Noise Level	1
13	Z94144	RH Rotation	1
14	Z94145	LH Rotation	1

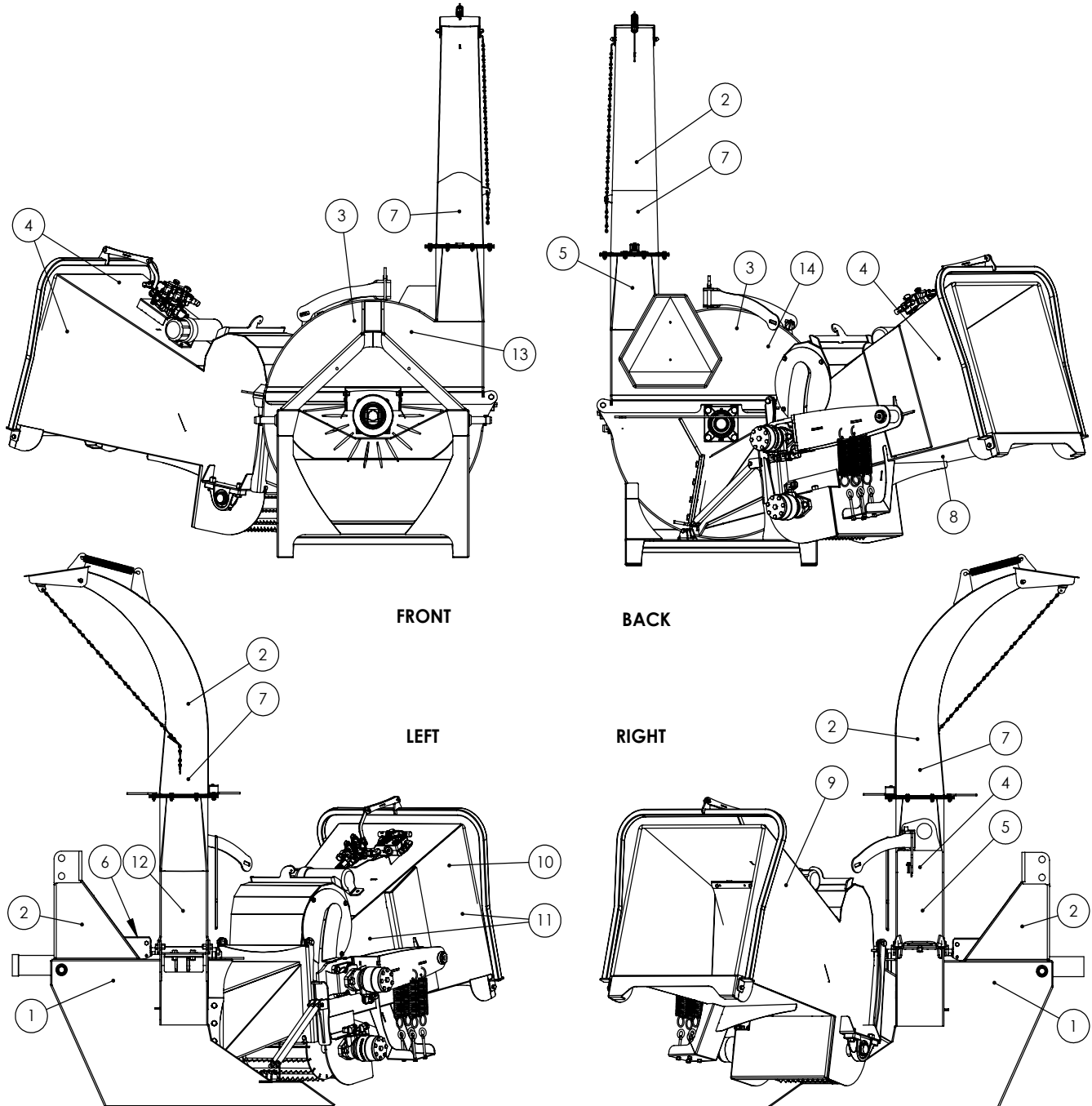

Two Panel Decals BX92R

Z94602



Z94167



Z94056



Z94072



Z94144



Z94019



Z94145

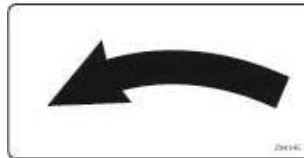

Z94015

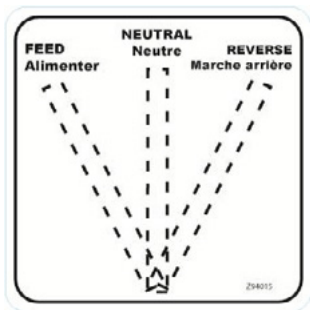

Z94014

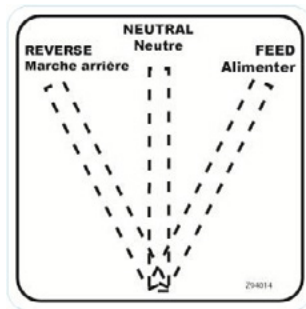

Z94143



Z94118



Z94117



Z94120

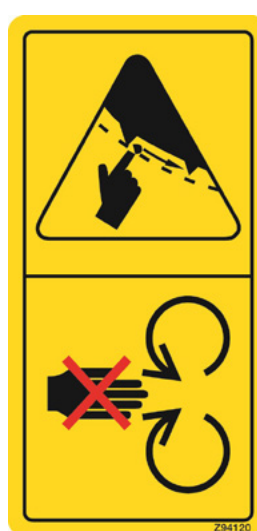

Z94119

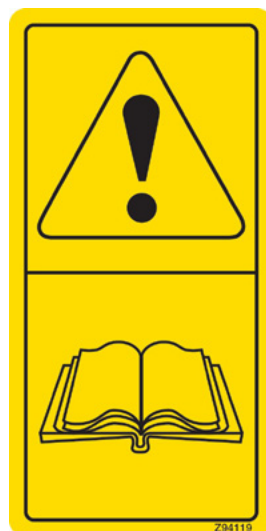



WALLENSTEIN Products Manufactured by:

EMB MFG Inc.

4144 Boomer Line
St. Clements, Ontario
Canada N0B 2M0
Phone: 1-877-695-9283
Fax: 519-699-4146
www.embmfg.com