



**WX460 Skidsteer  
Splitter Parts Manual  
Prior to S/N 246013**



## Foreword

EMB Mfg. has prepared this parts manual to assist customers in ordering quality OEM replacement parts.

Proper and regular service and replacing old, worn or broken parts with the correct Wallenstein parts are essential to prolonging the life of your Wallenstein product. Please refer to this manual before ordering any replacement parts.

All information contained in this parts manual is based on the latest product specification available at the time of printing this manual. If your product differs from the specifications contained within this manual contact EMB Mfg. for information.

EMB reserves the right to alter specifications on their products at any time.

Reproduction of this parts manual of any kind is prohibited without prior written permission from EMB Mfg.

# Table of Contents

Cylinder	4
Main Parts	5
Valve and Fittings	6
Valve	7
4-Way Wedge (Optional)	9
Decal Breakdown	10

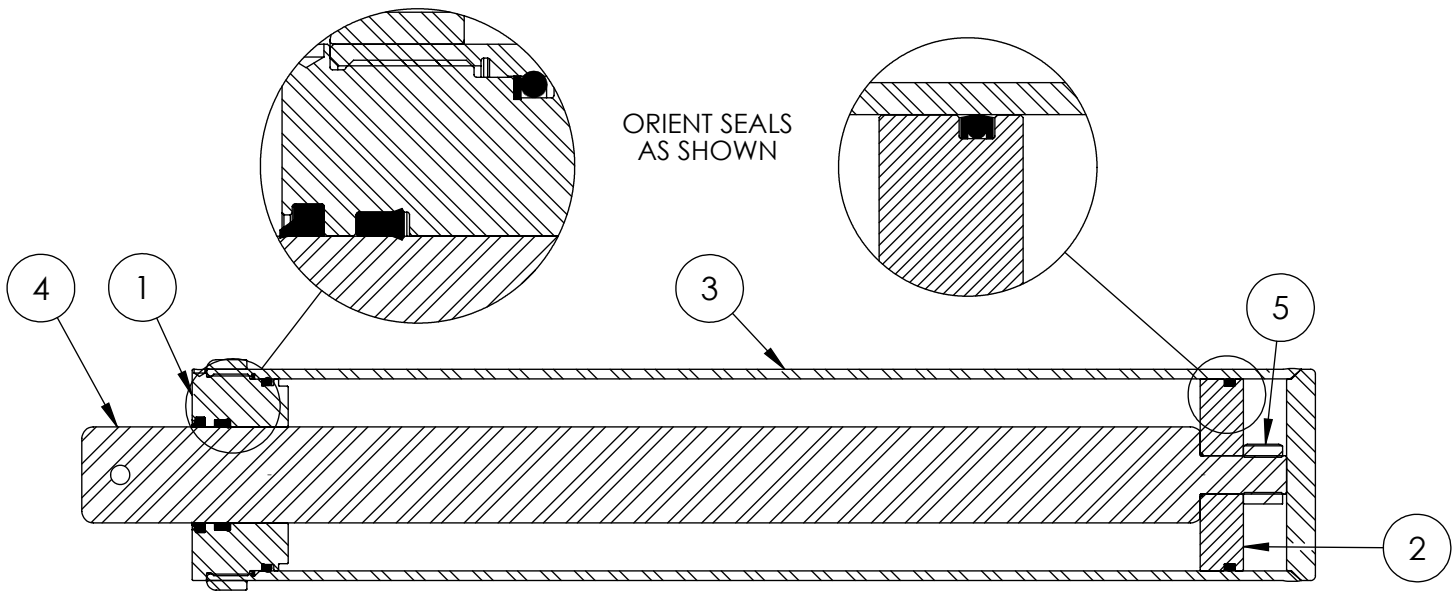

**5" x 24" STROKE CYLINDER PARTS**

ITEM	PART NO.	Description	QTY.
1	G500-250SA	5" Bore x 2-1/2" Rod Gland With Seals	1
2	P100-500SA	5" Bore Piston With Seals	1
3	2015C5014	Barrel, 5"	1
4	2015C5012	Rod, 2-1/2x 1	1
5	Z72292G8	Hex Lock Nut 1NF Grade 8	1
6	SLK-5025	Seal Kit, 5 x 2-1/2	1

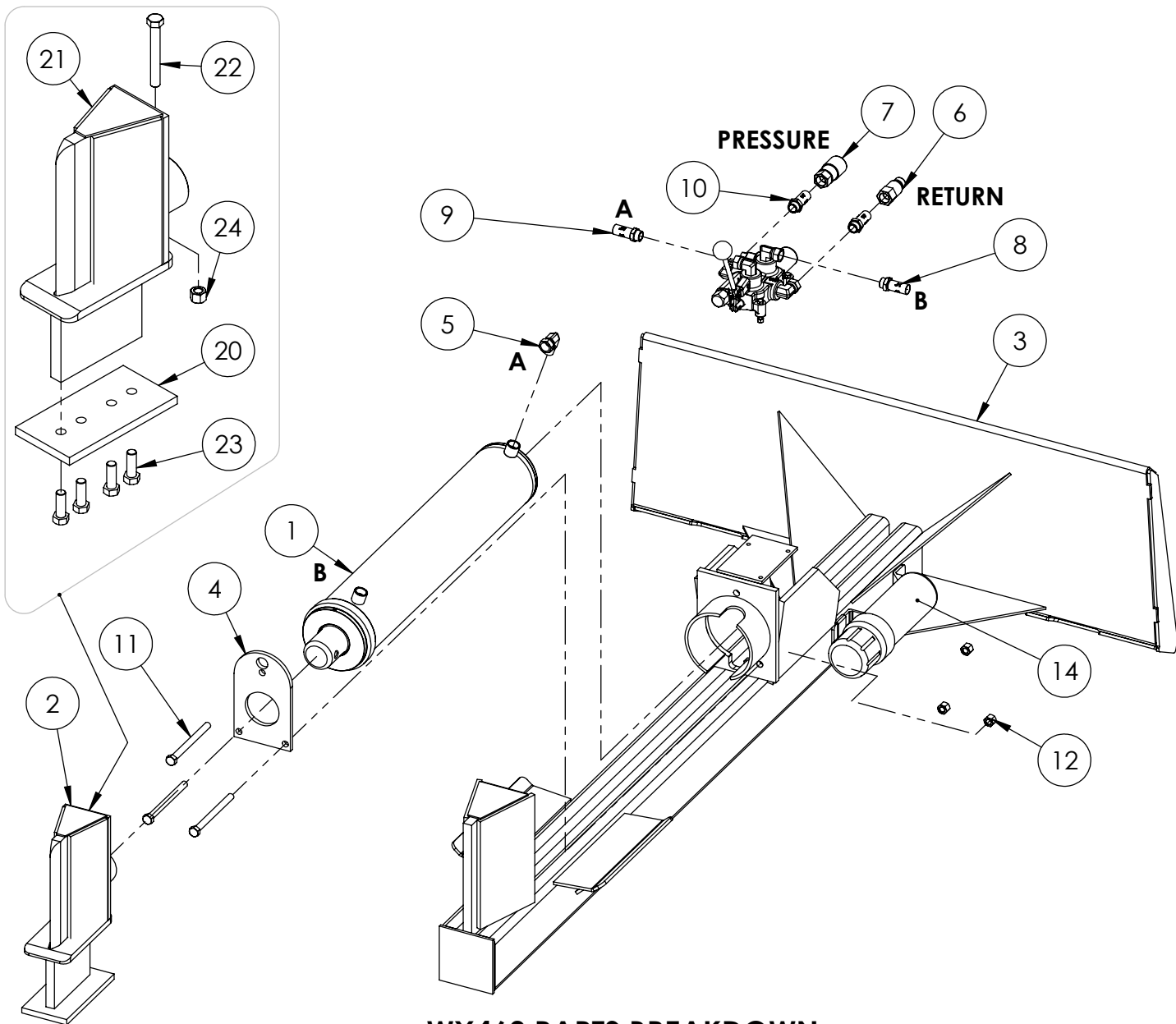

**WX460 PARTS BREAKDOWN**

ITEM	PART NO.	Description	QTY.
1	2015C501	Cylinder, 5 x 24" x 2-1/2	1
2	2015A505	Wedge Assy for 5" Cylinder	1
3	2035W501	Weldment, Main Frame	1
4	2061S121	Plate, Cylinder Retaining (Bolt)	1
5	Z51331	Elbow 90 MP x FPX 0808	1
6	Z51919	Flat-Face, FP08 x MISO16028	1
7	Z51920	Flat Face FP08 x FISO 16028	1
8	Z52301	1/2 Hose MP08 x MP08 x 16"	1
9	Z52305	1/2 Hose, MP08 x MP08 x 24"	1
10	Z52312	1/2 Hose, 1/2MPx1/2MPx 96"	2
11	Z71560	Hex Bolt 1/2NC x 6	3
12	Z72251	Hex Lock Nut 1/2NC	3
13	Z76712	Self-tapping Screw #10	1
14	Z96503	Manual Tube 3-1/2 Short	1
ITEM	PART NO.	Description	QTY.
20	2014S414	Plate, Sliding Wedge Capture	1
21	2015W505	Wedge for 5" Cylinder	1
22	Z71540	Hex Bolt 1/2NC x 4	1
23	Z71576	Hex Bolt 1/2NF x 1-1/2	4
24	Z72251	Hex Lock Nut 1/2NC	1

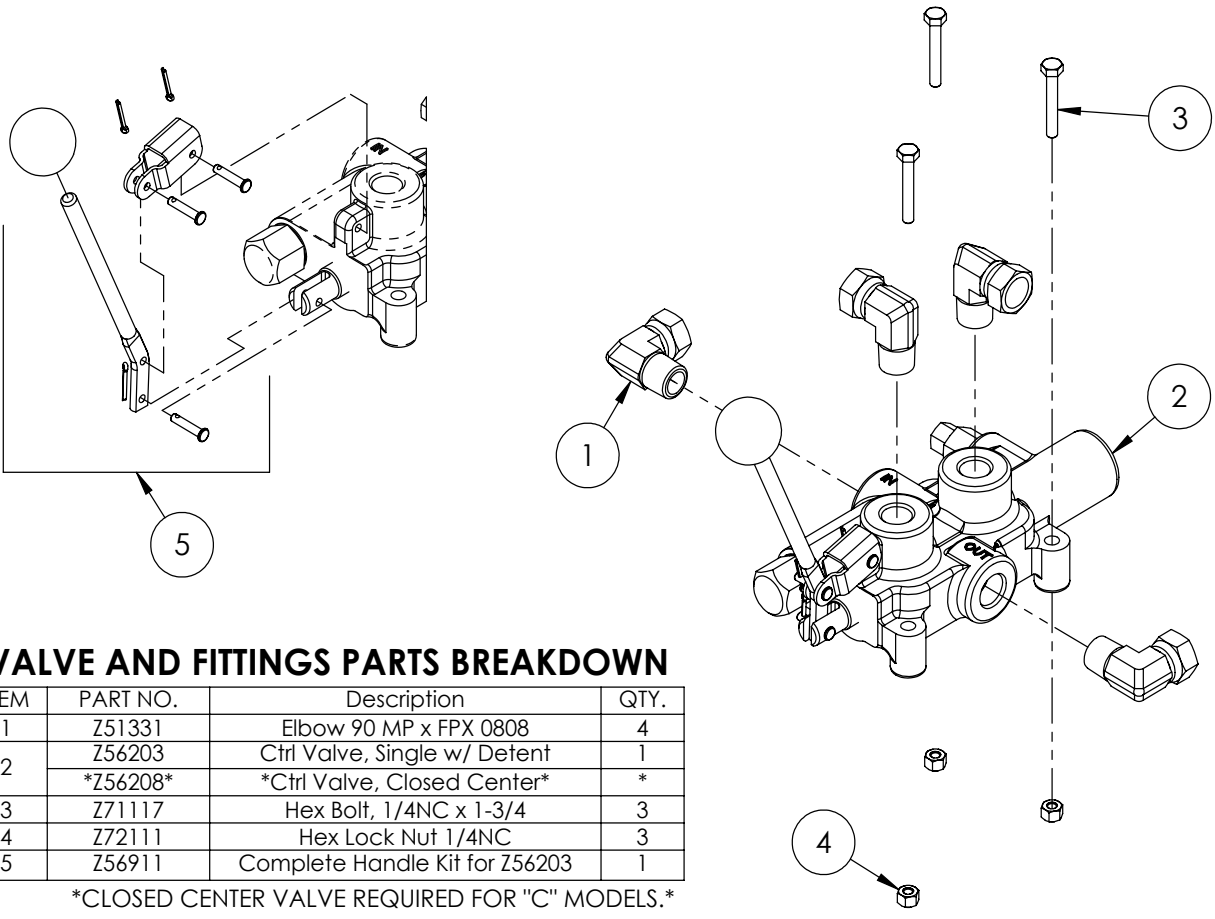

**VALVE AND FITTINGS PARTS BREAKDOWN**

ITEM	PART NO.	Description	QTY.
1	Z51331	Elbow 90 MP x FPX 0808	4
2	Z56203	Ctrl Valve, Single w/ Defent	1
	*Z56208*	*Ctrl Valve, Closed Center*	*
3	Z71117	Hex Bolt, 1/4NC x 1-3/4	3
4	Z72111	Hex Lock Nut 1/4NC	3
5	Z56911	Complete Handle Kit for Z56203	1

\*CLOSED CENTER VALVE REQUIRED FOR "C" MODELS.\*

# Z56203 Valve Breakdown

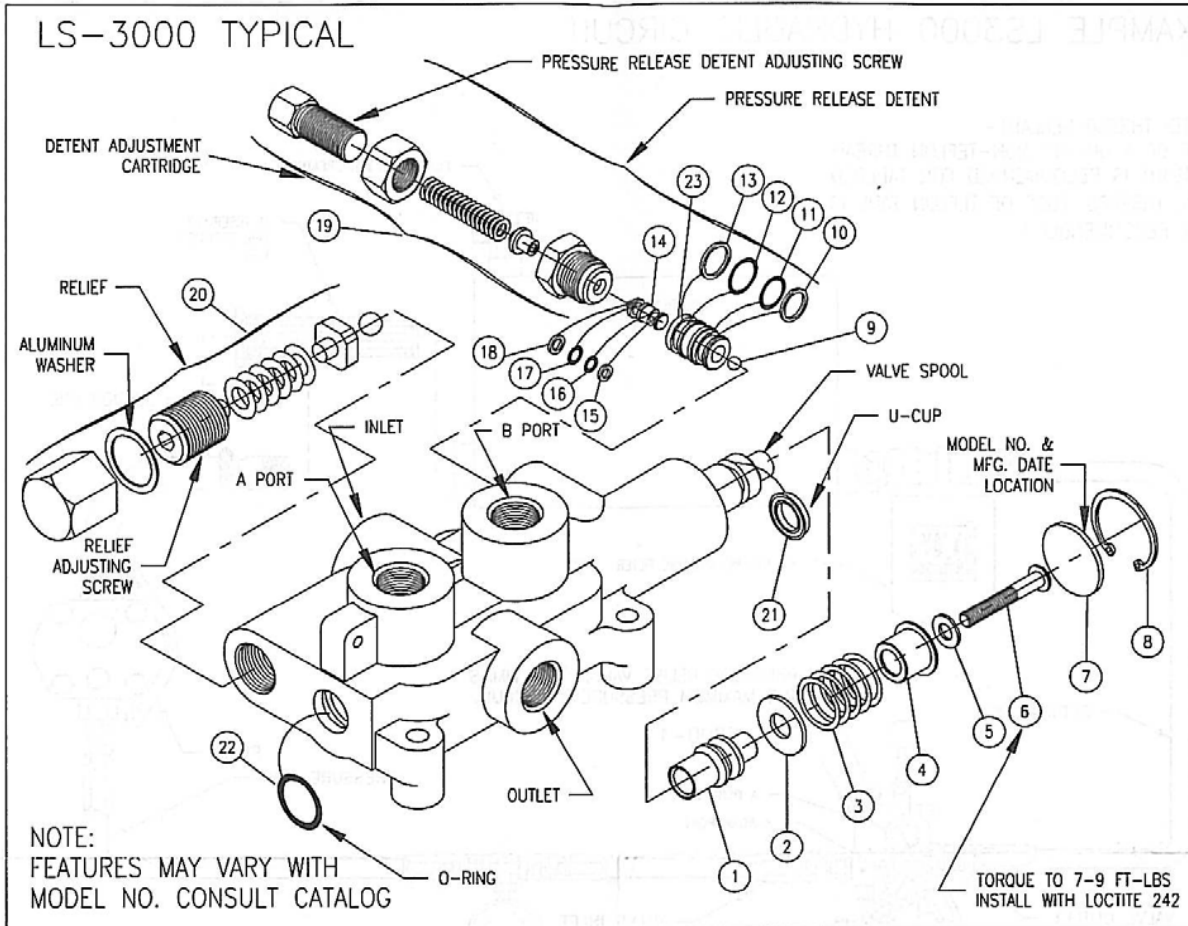

**PLEASE NOTE:**  
BEFORE REMOVING VALVE SPOOL OR SPOOL SLEEVE REMOVE DETENT ADJUSTING CART., DETENT PISTON AND STEEL BALL. INSTALL SPOOL AND SPOOL SLEEVE BEFORE REINSTALLING STEEL BALL.

## LS-3000 KITS AND CARTRIDGES

**PRESSURE RELEASE DETENT**  
This feature provides a pressure release detent for the spool 'out' (handle in) position. When the spool is manually placed in the detent position oil is directed to the 'B' work port (the port away from the handle). When the pressure in the 'B' port reaches a preset level the detent will release and the spool will center. The factory setting is 1400 psi. The detent release pressure is adjustable by loosening the jam nut and turning the adjusting screw. Turning the adjusting screw clockwise will increase the detent release pressure and counterclockwise will decrease the detent release pressure. NOTE: if the detent release pressure is set too high the spool will not center, if the pressure is too low the detent will not hold. If cap screw item 6 becomes loose detent will not function properly.

**RELIEF VALVE**  
An adjustable ball spring relief valve is standard on all LS-3000 valves. The standard factory setting is 2250 psi @ 3 gpm and 120°F. Other settings can be specified. The relief pressure is adjusted by removing acorn nut, and turning the adjusting screw. Turning the adjusting screw clockwise will increase the pressure and counterclockwise will decrease the pressure (a pressure gauge must be installed in the inlet line whenever the relief pressure is adjusted). Do not backout adjusting screw to the point it falls out.

ITEM	QTY	PART NO.	DESCRIPTION
1	1	670700019	DETENT SLEEVE
2	1	670500033	WASHER
3	1	670300020	SPRING
4	1	671400010	STOP CUP
5	1	670500026	WASHER
6	1	220000953	CAP SCREW
7	1	670500032	SPACER
8	1	230001125	SNAP RING
9	1	230009009	STEEL BALL
10	1	240019013	BACK-UP WASHER
11	1	240000013	O-RING
12	1	240000014	O-RING
13	1	240019014	BACK-UP WASHER
14	1	671100011	PISTON
15	1	240019007	BACK-UP WASHER
16	1	240016067	O-RING
17	1	240016068	O-RING
18	1	240019008	BACK-UP WASHER
19	1	660330002	DETENT ADJUSTING CART.
20	1	660125004	RELIEF KIT
21	1	240016086	U-CUP
22	1	240000210	O-RING
23	1	671100012	PISTON SLEEVE
			660530001 LS-3000 SEAL KIT
			660125004 RELIEF KIT
			660330002 DETENT ADJUSTING CART.
			660130007 PRESSURE RELEASE DETENT KIT
			660130001 COMPLETE HANDLE KIT

**⚠ WARNING: OVERPRESSURE MAY CAUSE SUDDEN AND UNEXPECTED FAILURE OF A COMPONENT IN THE HYDRAULIC SYSTEM RESULTING IN SERIOUS PERSONAL INJURY. ALWAYS USE A GAUGE WHEN ADJUSTING A RELIEF VALVE.**

This Page is Intentionally Blank



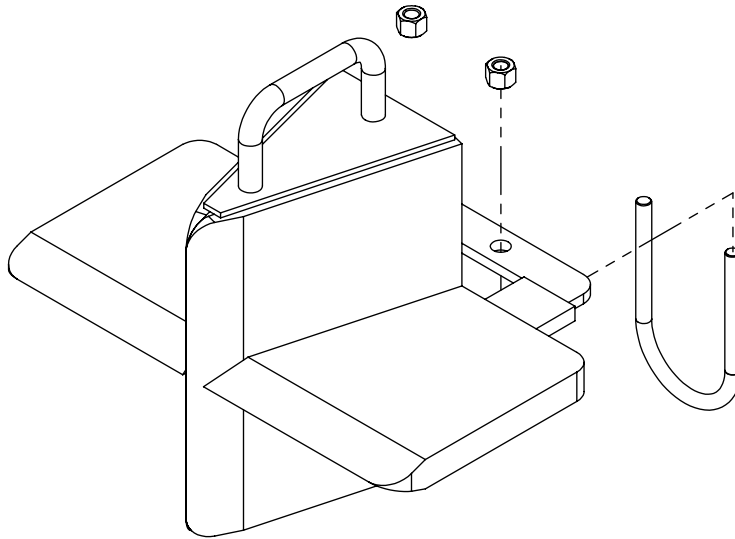

### W4120 4-Way Wedge (Optional)

ITEM	PART NO.	DESCRIPTION	QTY
1	2082W201	Weldment, Main W4120	1
2	2082S201	Safety U-bolt	1
3	Z72231	Hex Lock Nut 3/8NC	2

### WX460 DECAL BREAKDOWN

ITEM	PART NO.	DESCRIPTION	QTY
1	Z94039	CAUTION - Read Manual	1
2	Z94040	WARNING - Moving Wedge	2
3	Z94067	Clear Guide	2
4	Z94056	Wallenstein	2
5	Z94019	Made in Canada	3
6	Z94066	Apply Oil or Grease	1

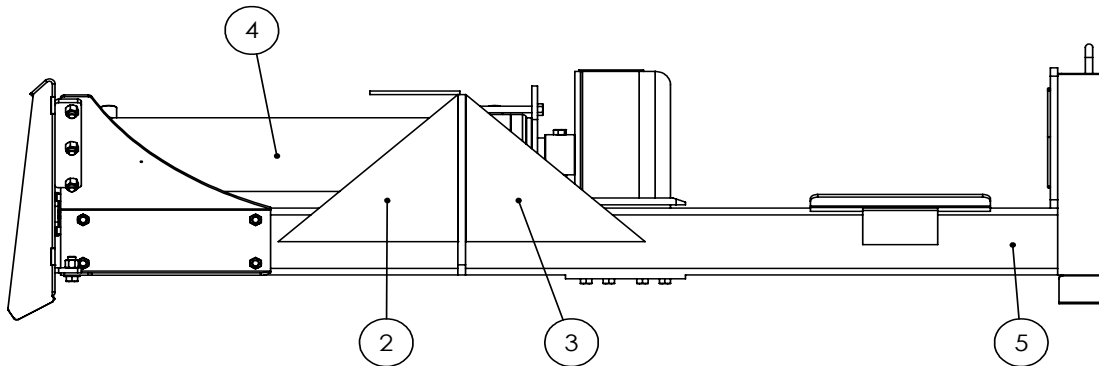
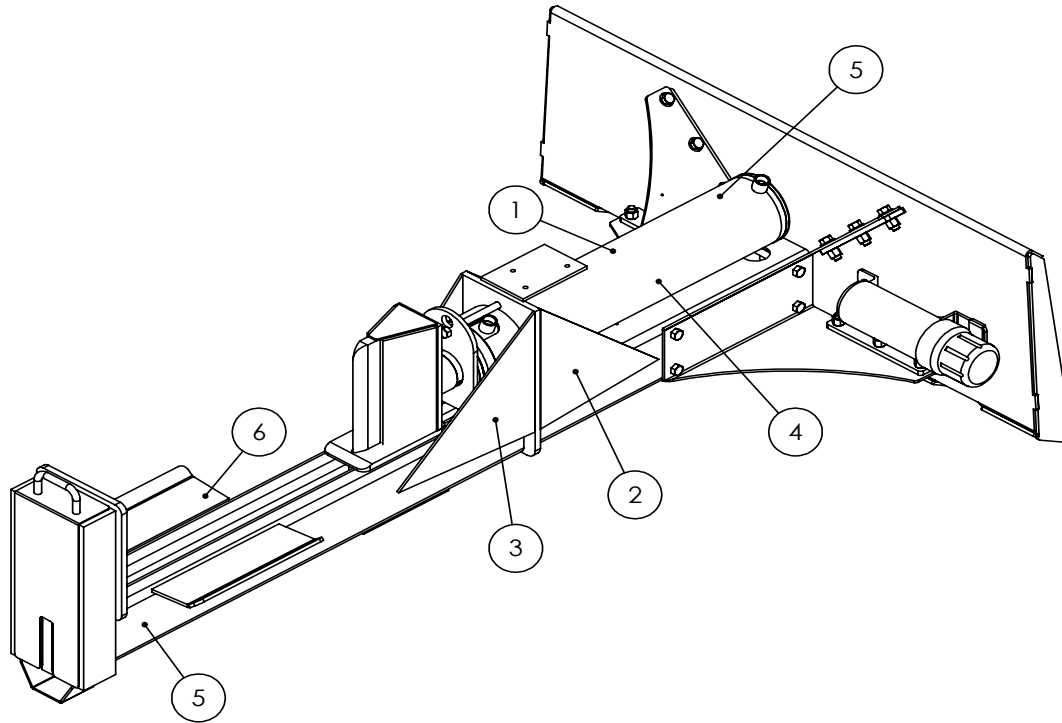

## Skidsteer Splitter Decals

Z94056



Z94067



Z94019



Z94066



Z94039

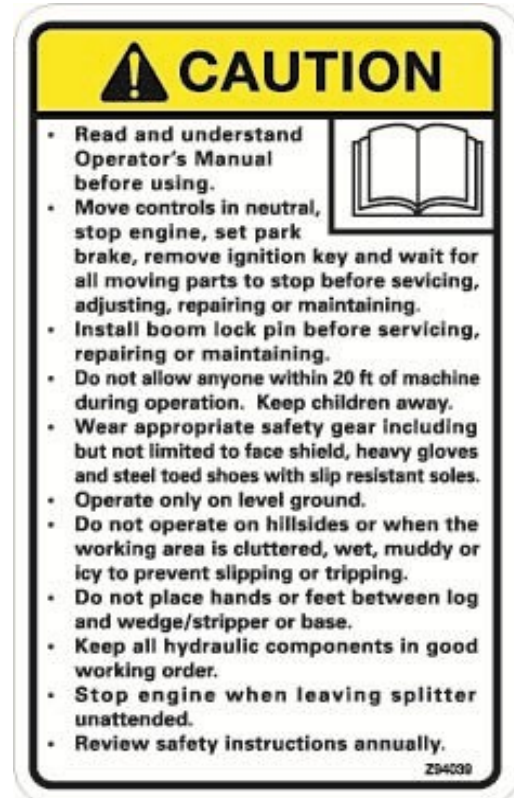

Z94040





**WALLENSTEIN Products Manufactured by:**

**EMB MFG Inc.**

4144 Boomer Line  
St. Clements, Ontario  
Canada N0B 2M0  
Phone: 1-877-695-9283  
Fax: 519-699-4146  
[www.embmfg.com](http://www.embmfg.com)