

PARTS MANUAL

Serial Number 320R001 & Up

LXG320R THREE-POINT HITCH LOG GRAPPLE

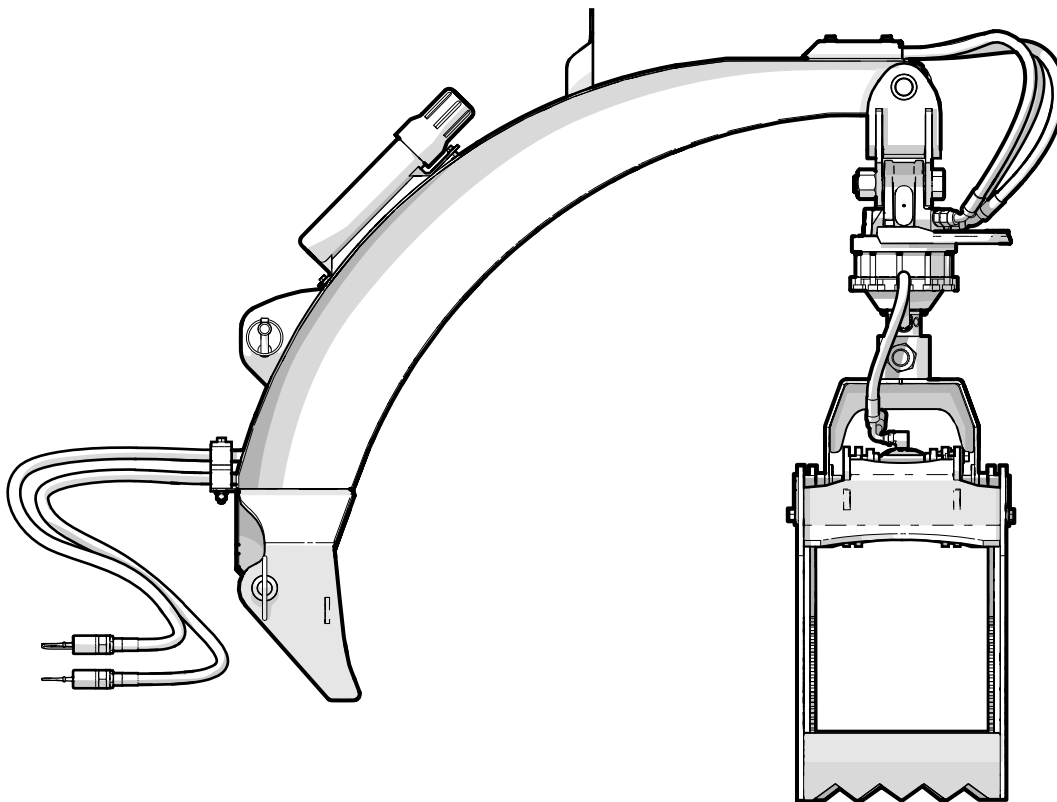

Foreword

This Wallenstein parts manual is prepared to assist customers in ordering quality OEM replacement parts.

Regular maintenance combined with replacing old, worn or broken parts with the correct OEM parts is essential in prolonging the life of your Wallenstein product. Refer to this manual to identify replacement parts.

To order parts, contact your Wallenstein dealer or distributor. Have the product model and serial number handy.

If your dealer is no longer available, please go to our website: <http://wallensteinequipment.com> and click on the [Dealer Locator](#) to find the nearest dealer.

All information contained in this parts manual is current as per the revision date at the bottom of the page. Wallenstein reserves the right to change product specifications at any time without notice.

If your product specifications differ from those contained in this manual, contact Wallenstein for current information.

Reproduction of information in this parts manual is prohibited without prior written permission from Wallenstein Equipment Inc.

Wallenstein Equipment Inc. • © 2021

WARNING!

Refer to the operators manual for safe operation and maintenance.

Maintenance should be performed by trained personnel only.

Serial Number Location

Always provide the model and serial number of your Wallenstein product when ordering parts or requesting service or other information. This information is found on the product information plate as shown below.

Record your product information here for future reference.

Model _____

Serial Number _____

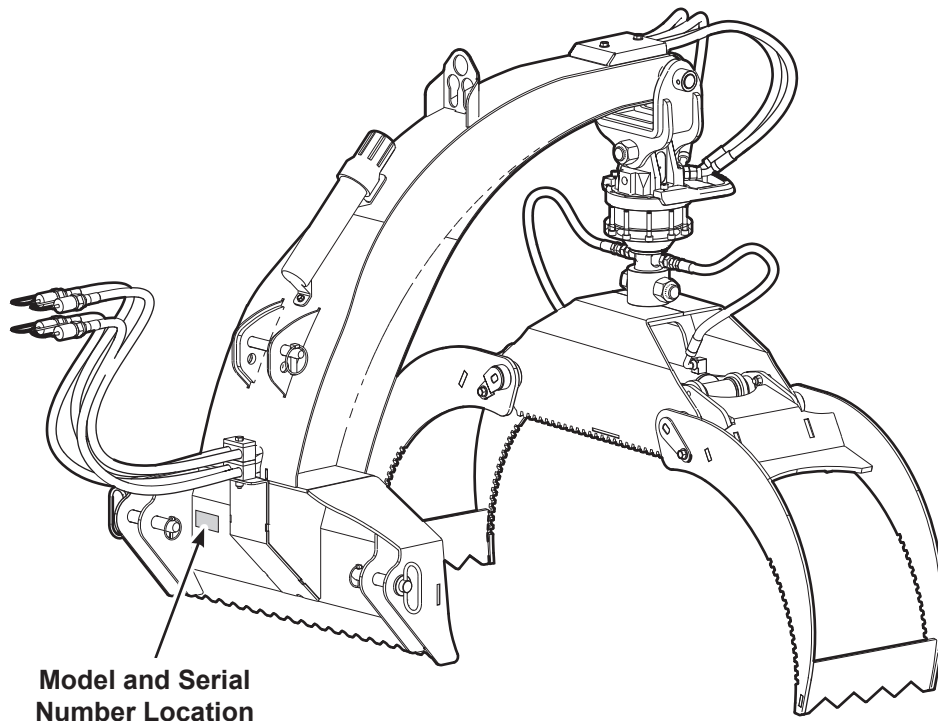

**Model and Serial
Number Location**

www.wallensteinequipment.com

Contents

Main Parts S/N 320R001 to 320R089	4-A
Main Parts S/N 320R090 & Up.....	4-B
Grapple Assembly S/N 320R001 to 320R089	5-A
Grapple Assembly S/N 320R090 & Up.....	5-B
Outer Fork Assembly Detail S/N 320R001 to 320R89	6A
Outer Fork Assembly Detail S/N 320R090 & Up.....	6B
Cylinder Detail.....	7
Hydraulic Circuit.....	8
Decal Layout.....	9
Accessories.....	10
Bolt Torque	11
Hydraulic Fitting Torque.....	12

Main Parts S/N 320R001 to 320R089

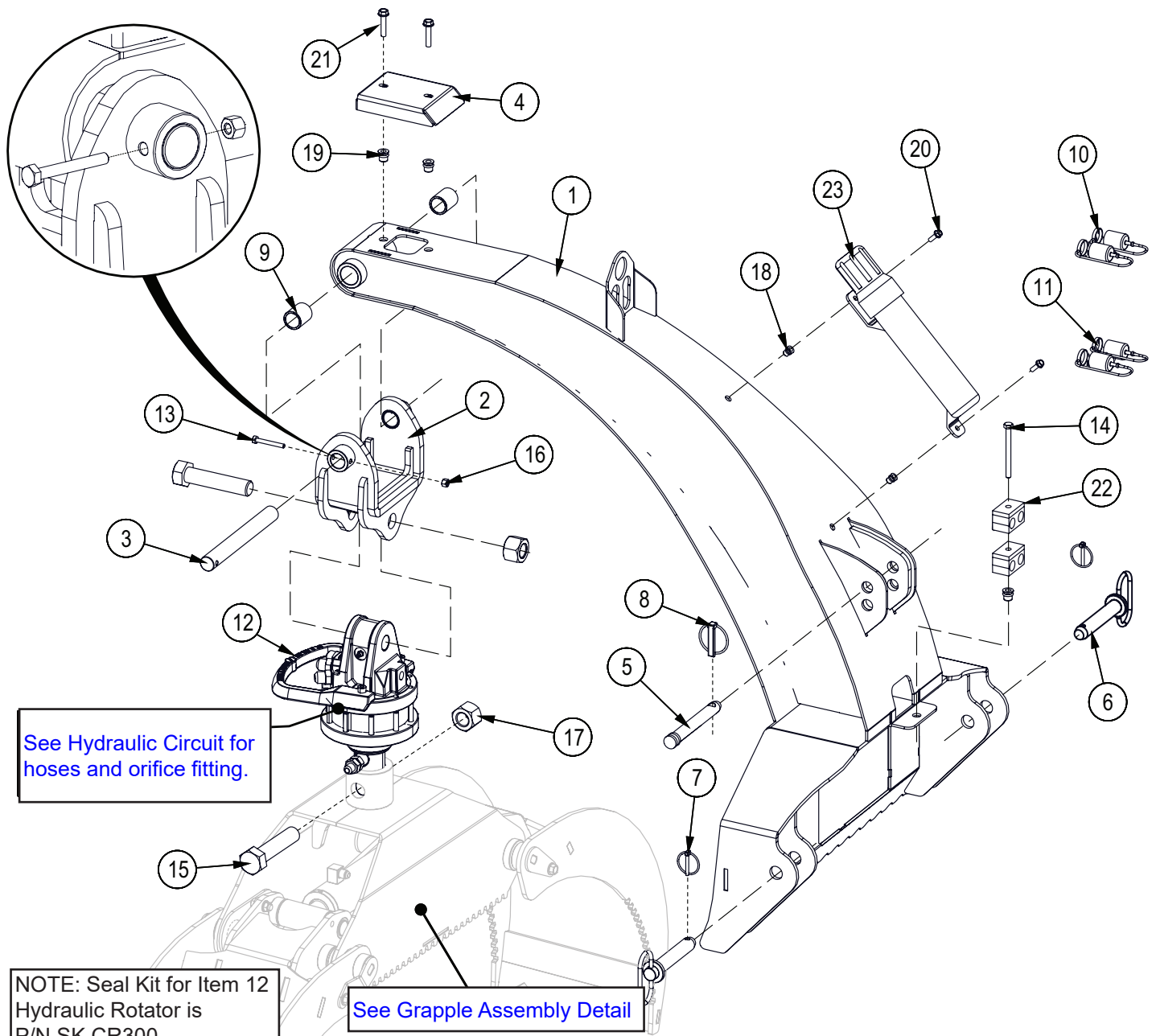

Item No.	Part No.	Description	Qty
1	6018W005	Mainframe	1
2	6018W007	Hanger	1
3	6018M015	Pin, Rotator Mount	1
4	6018L031	Cover, Hydraulic Hose	1
5	Z11123	Toplink Pin, 3/4" x 4-3/4"	1
6	Z11251	Hitch Pin, 7/8" x 4-1/4"	2
7	Z12110	Lynch Pin, 3/16"	2
8	Z12140	Lynch Pin, 7/16"	1
9	Z27109	Composite Bearing, 1" ID x 1-1/2"L x 1/8" Wall	2
10	Z52831	Nipple Cap, ISO 7241-1 x Red	2
11	Z52832	Nipple Cap, ISO 7241-1 x Black	2
12	Z54107	Hydraulic Rotator, CR300W	1

Item No.	Part No.	Description	Qty
13	Z71120	Hex Bolt, 1/4NC x 2"	1
14	Z71235	Hex Bolt, 5/16NC x 3-1/2"	1
15	Z71911	Hex Bolt, 1NC x 4-1/2"	2
16	Z72211	Hex Lock Nut, 1/4NC	1
17	Z72291	Hex Lock Nut, 1NC	2
18	Z72955	Rivet Nut, 1/4NC x 165	2
19	Z72956	Rivet Nut, 5/16NC x 150	3
20	Z76111	Flange Bolt, 1/4NC x 3/4"	2
21	Z76123	Flange Bolt, 5/16NC x 1-1/2"	2
22	Z79463	Double Hose Clamp, 11/16" OD	2
23	Z96505	Manual Tube, 2" Short	1

Main Parts S/N 320R090 & Up

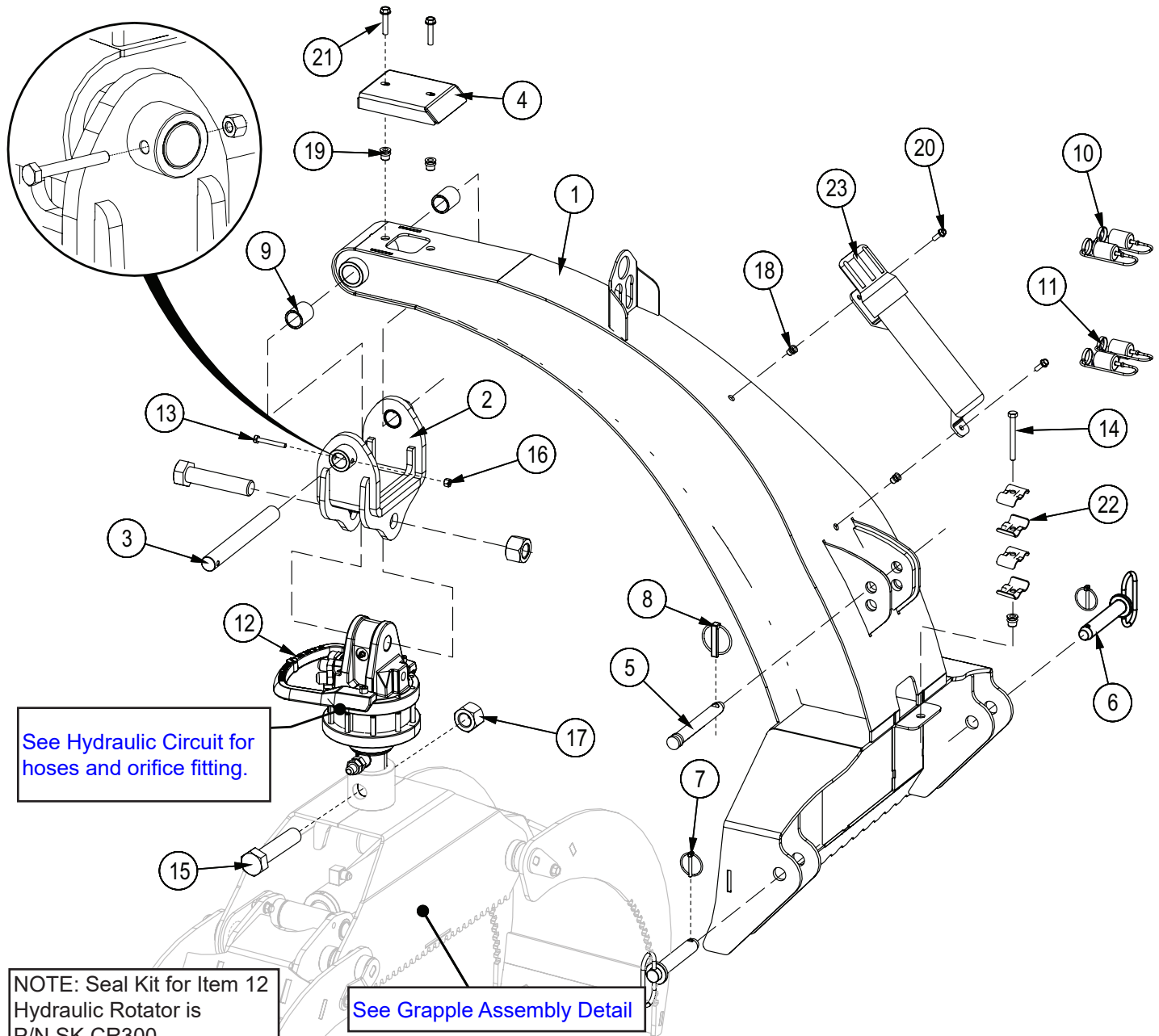

See Hydraulic Circuit for hoses and orifice fitting.

NOTE: Seal Kit for Item 12 Hydraulic Rotator is P/N SK CR300

See Grapple Assembly Detail

Item No.	Part No.	Description	Qty
1	6018W005	Mainframe	1
2	6018W007	Hanger	1
3	6018M015	Pin, Rotator Mount	1
4	6018L031	Cover, Hydraulic Hose	1
5	Z11123	Toplink Pin, 3/4" x 4-3/4"	1
6	Z11251	Hitch Pin, 7/8" x 4-1/4"	2
7	Z12110	Lynch Pin, 3/16"	2
8	Z12140	Lynch Pin, 7/16"	1
9	Z27109	Composite Bearing, 1" ID x 1-1/2"L x 1/8" Wall	2
10	Z52831	Nipple Cap, ISO 7241-1 x Red	2
11	Z52832	Nipple Cap, ISO 7241-1 x Black	2
12	Z54107	Hydraulic Rotator, CR300W	1

Item No.	Part No.	Description	Qty
13	Z71120	Hex Bolt, 1/4NC x 2"	1
14	Z71225	Hex Bolt, 5/16NC x 2-1/2"	1
15	Z71911	Hex Bolt, 1NC x 4-1/2"	2
16	Z72211	Hex Lock Nut, 1/4NC	1
17	Z72291	Hex Lock Nut, 1NC	2
18	Z72955	Rivet Nut, 1/4NC x 165	2
19	Z72956	Rivet Nut, 5/16NC x 150	3
20	Z76111	Flange Bolt, 1/4NC x 3/4"	2
21	Z76123	Flange Bolt, 5/16NC x 1-1/2"	2
22	2250L286	Hose Clamp 2 x 3/8"	4
23	Z96505	Manual Tube, 2" Short	1

Grapple Assembly S/N 320R001 to 320R089

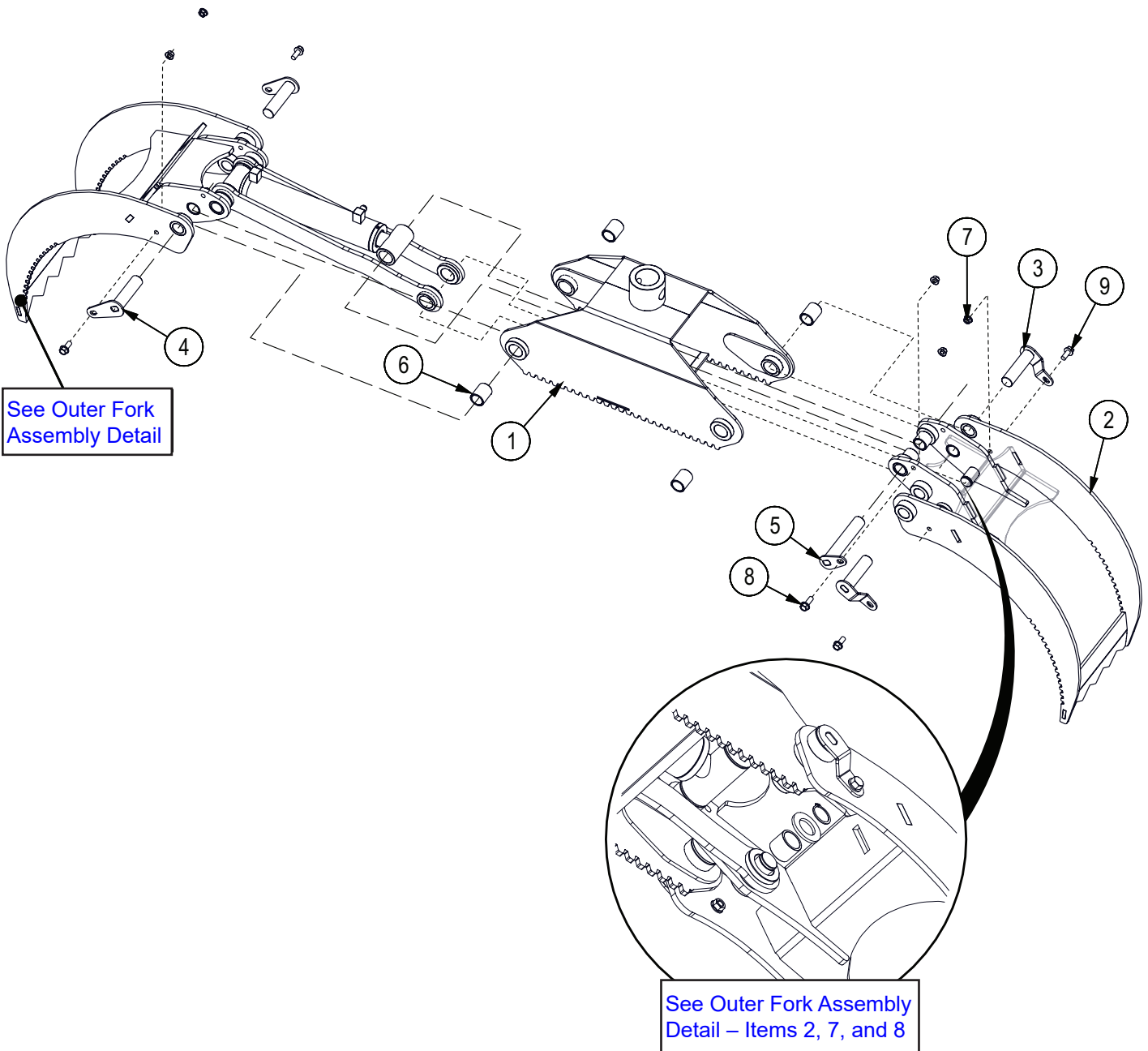

Item No.	Part No.	Description	Qty
1	6018W001	Grapple Housing	1
2	6018W002	Inner Fork	1
3	6018W008	Inner Fork Pin	2
4	6018W009	Outer Fork Pin	2
5	6018W010	Short Cylinder Pin	1
6	Z27109	Composite Bearing, 1" ID x 1-1/2" long x 1/8" Wall	4
7	Z72531	Serrated Flange Locknut, 3/8NC	5
8	Z76134	Flange Bolt, 3/8NC x 1"	1
9	Z76139	Flange Bolt, 3/8NC x 7/8"	4

Grapple Assembly S/N 320R090 & Up

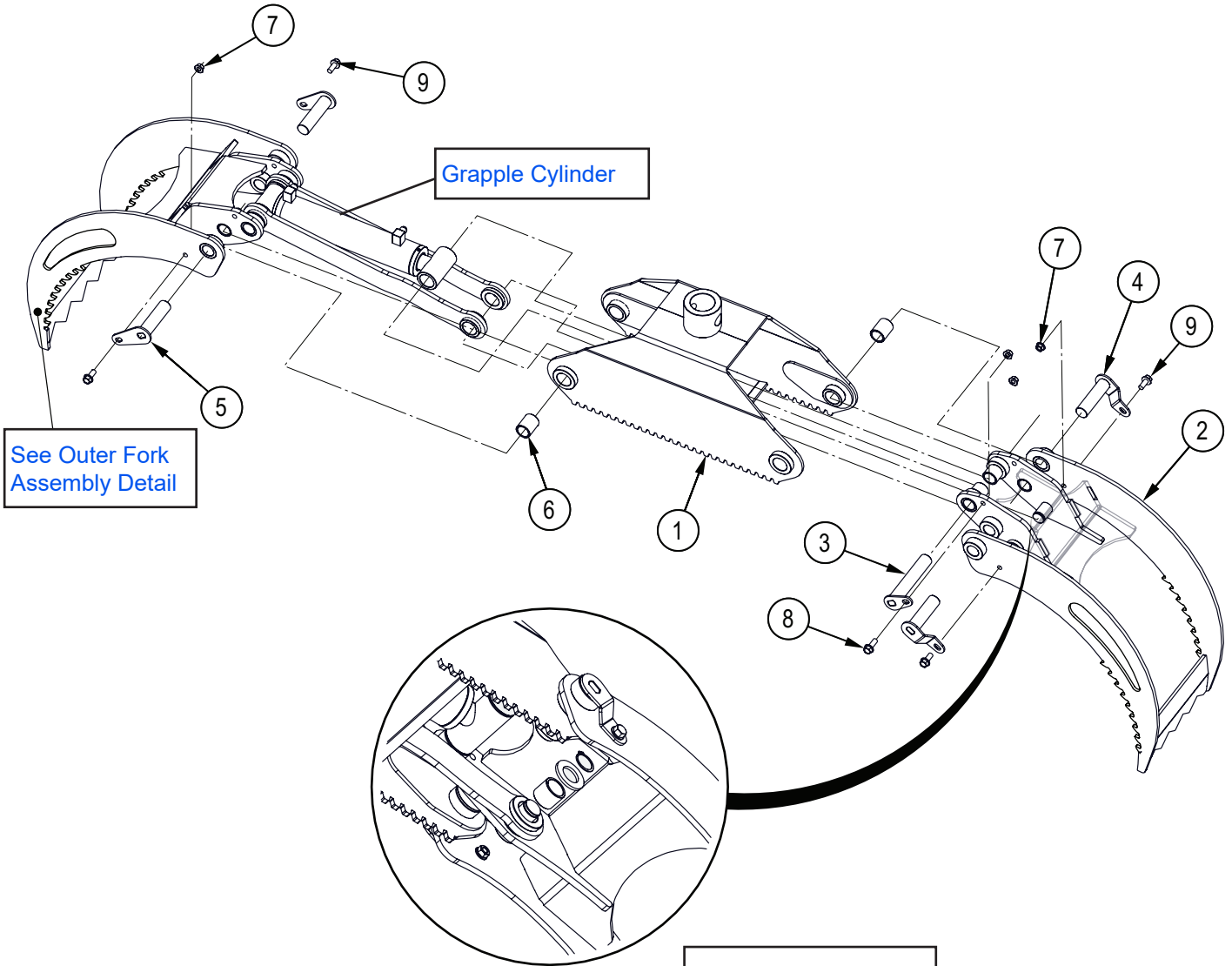

Note: See Outer Fork Assembly Detail – Items 2, 7, and 8

Item No.	Part No.	Description	Qty
1	6018W001	Grapple Housing	1
2	6018W012	Inner Fork	1
3	6018W010	Short Cylinder Pin	1
4	6018W008	Inner Fork Pin	2
5	6018W009	Outer Fork Pin	2
6	Z27109	Composite Bearing, 1" ID x 1-1/2" long x 1/8" Wall	4
7	Z72531	Serrated Flange Locknut, 3/8NC	5
8	Z76134	Flange Bolt, 3/8NC x 1"	1
9	Z76139	Flange Bolt, 3/8NC x 1"	4

Outer Fork Assembly Detail S/N 320R001 to 320R89

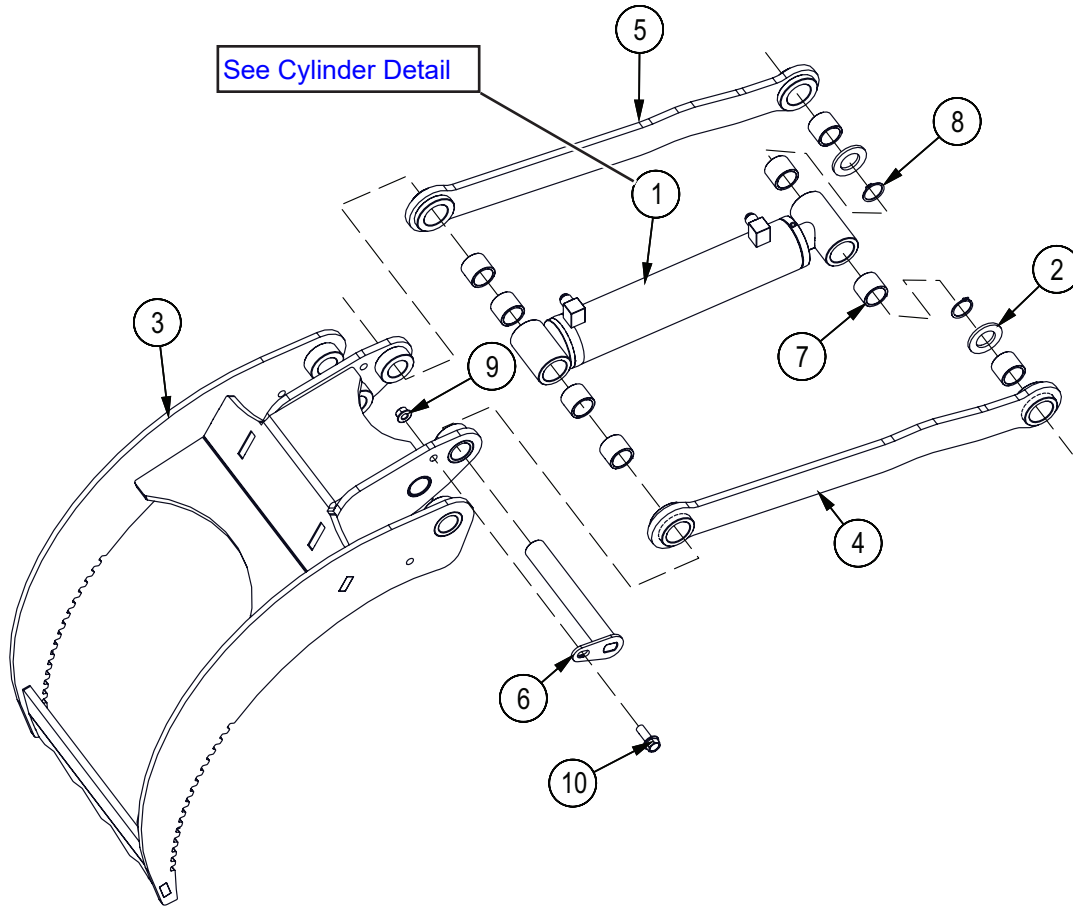

Item No.	Part No.	Description	Qty
1	6018C001	Cylinder, 2" x 1-1/4" x 8-5/8"	1
2	6018L026	Washer, Linkage Retaining	2
3	6018W003	Outer Fork	1
4	6018W004	Linkage	1
5	6018W004H	Linkage Mirror	1
6	6018W011	Long Cylinder Pin	1
7	Z27110	Composite Bearing, 1" ID x 1" long x 1/8" Wall	8
8	Z46204	External Retaining Ring, 1"	2
9	Z72531	Serrated Flange Locknut, 3/8NC	1
10	Z76134	Flange Bolt, 3/8NC x 1"	1

Outer Fork Assembly Detail S/N 320R090 & Up

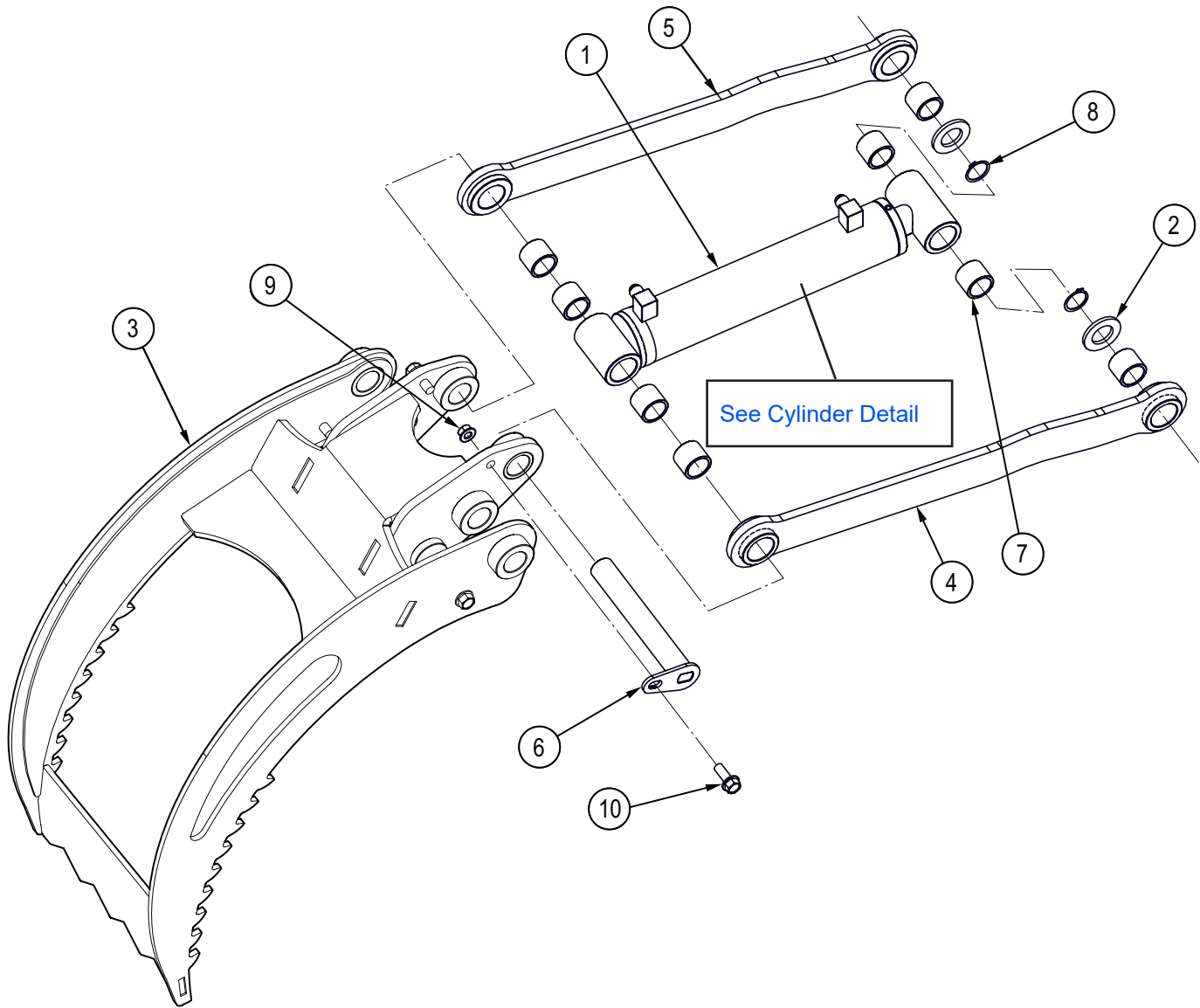

Item No.	Part No.	Description	Qty
1	6018C001	Cylinder, 2" x 1-1/4" x 8-5/8"	1
2	6018L026	Washer, Linkage Retaining	2
3	6018W013	Outer Fork	1
4	6018W004	Linkage	1
5	6018W004H	Linkage Mirror	1
6	6018W011	Long Cylinder Pin	1
7	Z27110	Composite Bearing, 1" ID x 1" long x 1/8" Wall	8
8	Z46204	External Retaining Ring, 1"	2
9	Z72531	Serrated Flange Locknut, 3/8NC	1
10	Z76134	Flange Bolt, 3/8NC x 1"	1

Cylinder Detail

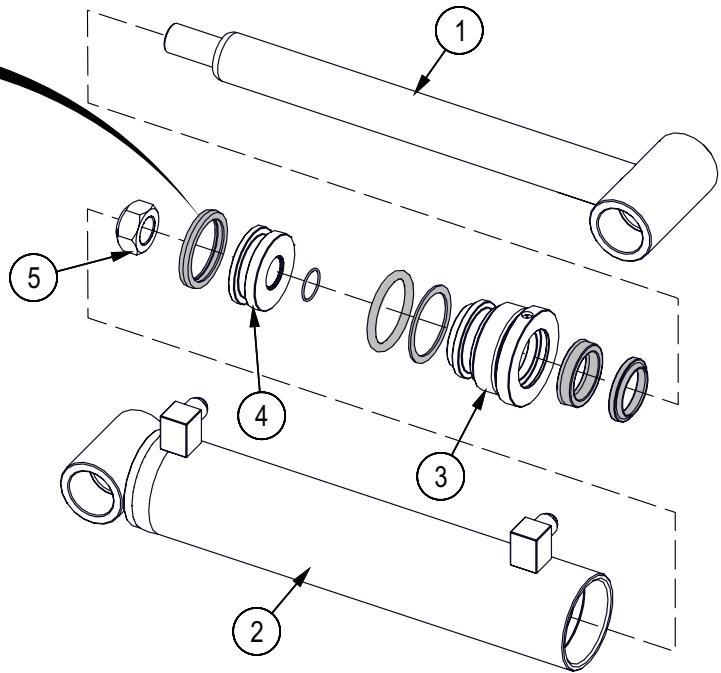

Item No.	Part No.	Description	Qty
1	6018C0013	Rod, 1-1/4" x 3/4NF	1
2	6018C0014	Barrel, 2"	1
3	G200-125S	Gland, 2" x 1-1/4"	1
4	P750-200SP	Piston, 2" Bore	1
5	Z72276G8	Hex Top-lock Nut, 3/4NF G8	1

Hydraulic Circuit

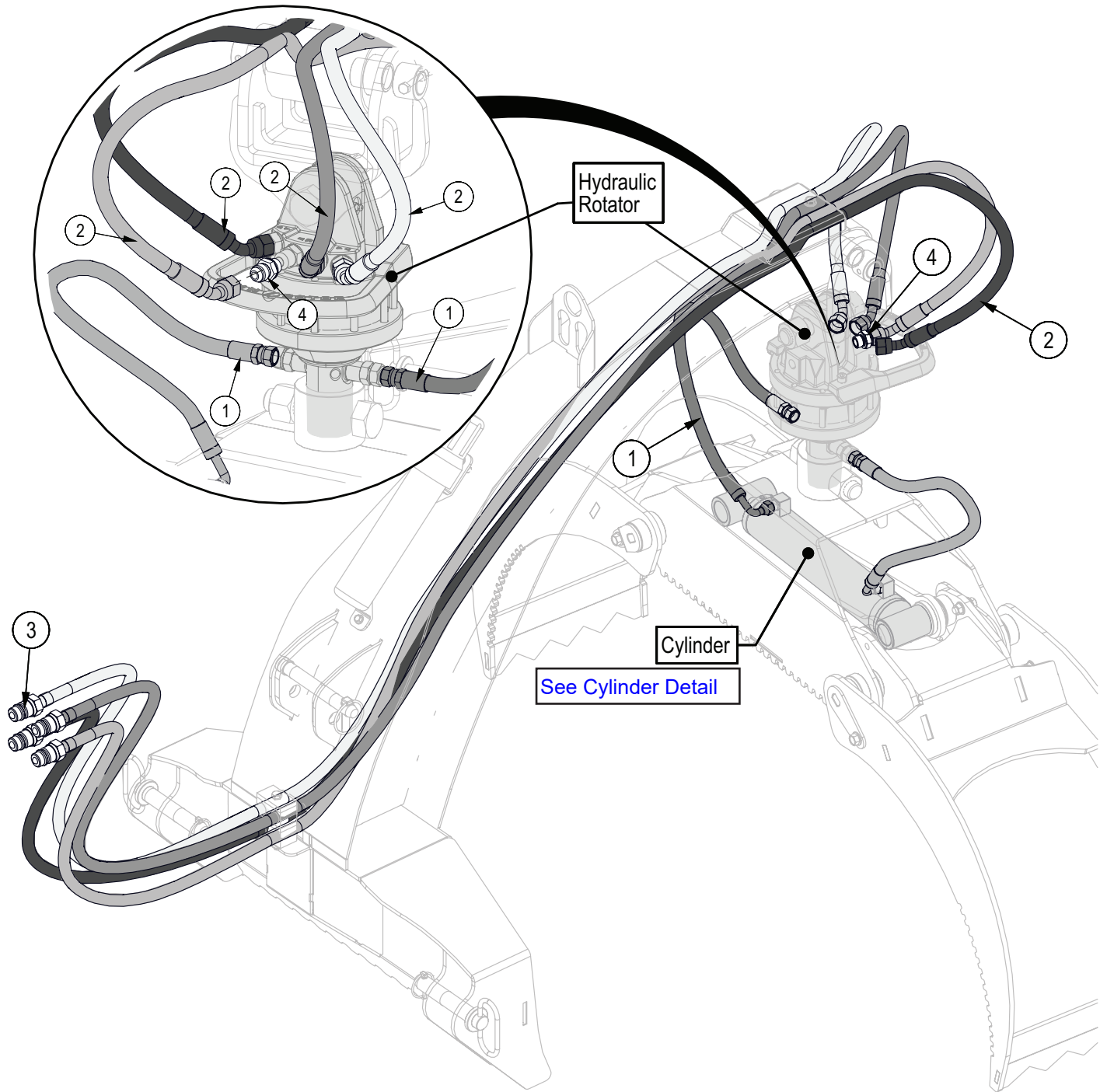

Item No.	Part No.	Description	Qty
1	6018F001	3/8" Hose, FJIC06 x 90FJIC06 x 21"	2
2	6018F002	3/8" Hose, 45FJIC08 x MP08 x 108"	4
3	Z51926	Quick Coupler, FP08 x M ISO 7241-1	4
4	Z51937	Straight, MJIC x MBSPP 0806 x 0.047" Orifice	1

Decal Layout

IMPORTANT! If parts are replaced that have safety signs on them, new signs must be applied. Safety signs must always be replaced if they become damaged, are removed, or become illegible.

Safety signs are included in the product decal kit available from your authorized dealer. Decals are not available separately.

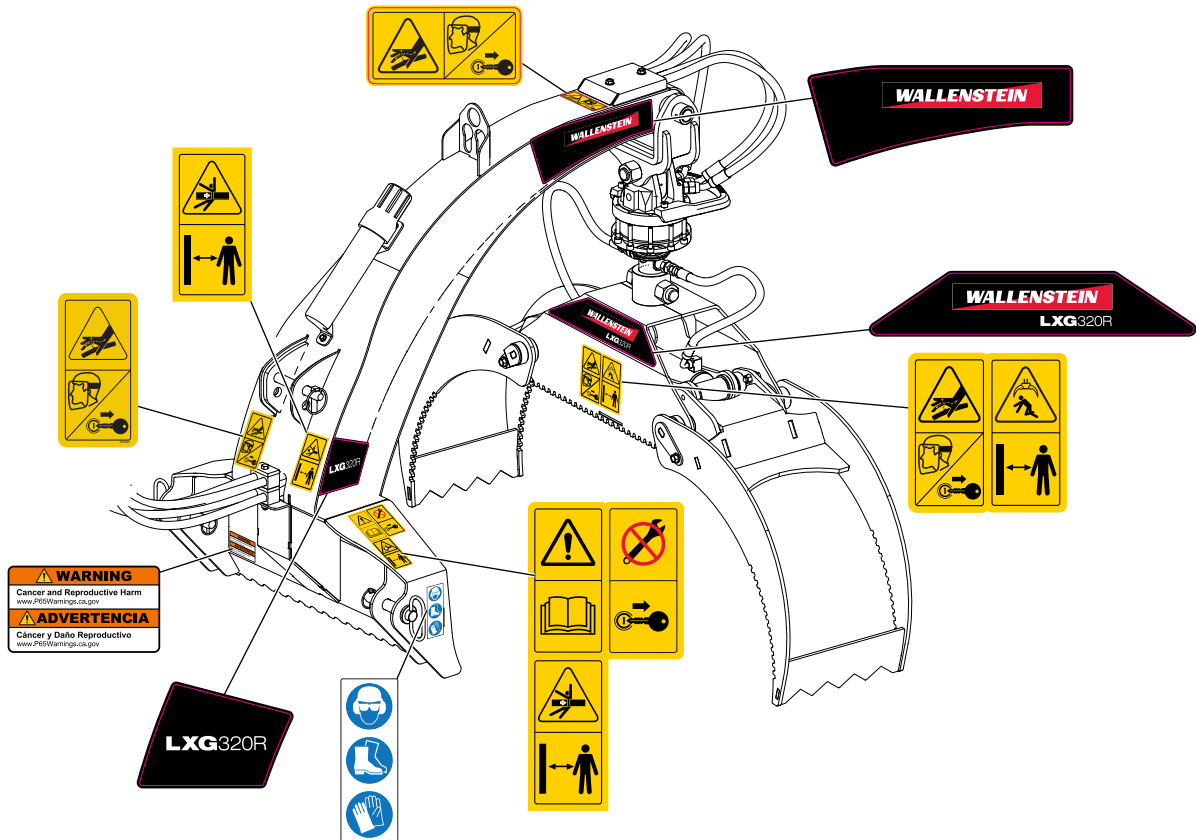
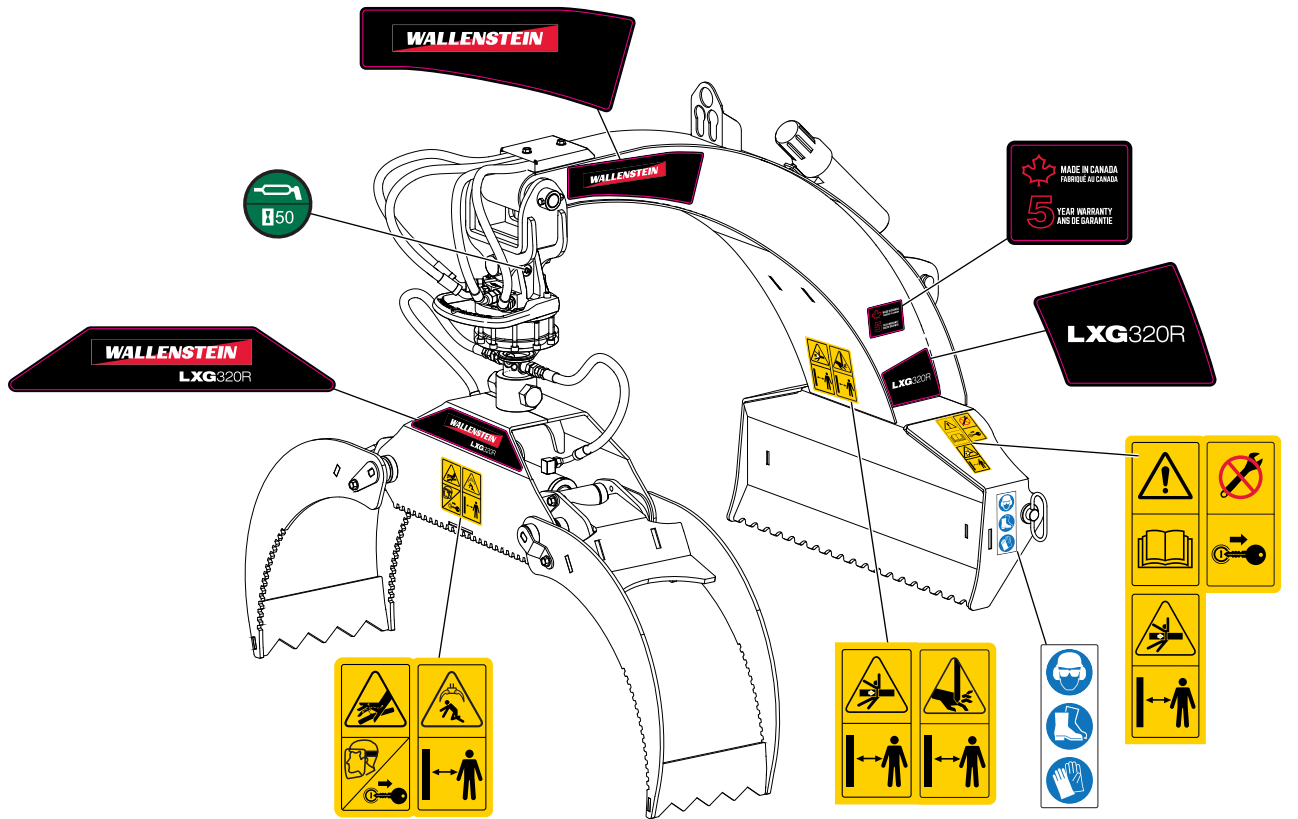

Accessories

Call your dealer for pricing and availability

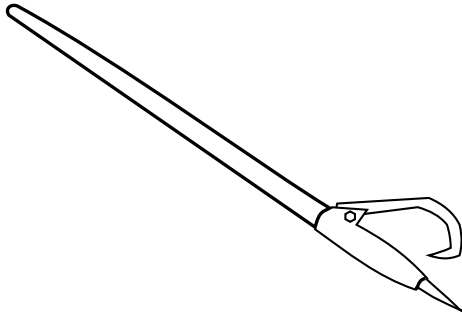
**48" Log Peavey – P/N Z99001**

Quality 2-3/8" diameter hardwood handle, with a Western Duck Bill Hook.
Helps to move those heavy log timbers into position.

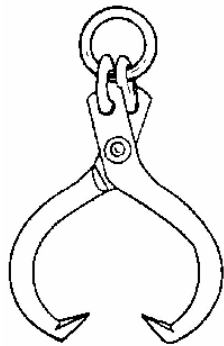
**Skidding Tongs – P/N Z99003**

Heavy Duty Forged Ring Skidding Tongs
Maximum Opening: 25"
Minimum Opening: 4-1/2"
Tough log skidding tongs are a quick and easy way to skid logs.

Bolt Torque

Checking Bolt Torque

The tables shown give correct torque values for various bolts and capscrews. Tighten all bolts to the torque values specified in the table, unless indicated otherwise. Check tightness of bolts periodically.

IMPORTANT! If replacing hardware, use fasteners of the same grade.

IMPORTANT! Torque figures indicated in the table are for non-greased or non-oiled threads. Do not grease or oil threads unless indicated otherwise. When using a thread locker, increase torque values by 5%.

 **NOTE:** Bolt grades are identified by their head markings.

Imperial Bolt Torque Specifications

Bolt Diameter	Torque Value					
	SAE Gr. 2		SAE Gr. 5		SAE Gr. 8	
	lbf•ft	N•m	lbf•ft	N•m	lbf•ft	N•m
1/4"	6	8	9	12	12	17
5/16"	10	13	19	25	27	36
3/8"	20	27	33	45	45	63
7/16"	30	41	53	72	75	100
1/2"	45	61	80	110	115	155
9/16"	60	95	115	155	165	220
5/8"	95	128	160	215	220	305
3/4"	165	225	290	390	400	540
7/8"	170	230	420	570	650	880
1"	225	345	630	850	970	1320



SAE Gr. 2



SAE Gr. 5



SAE Gr. 8

Metric Bolt Torque Specifications

Bolt Diameter	Torque Value			
	Gr. 8.8		Gr. 10.9	
	lbf•ft	N•m	lbf•ft	N•m
M3	0.4	0.5	1.3	1.8
M4	2.2	3	3.3	4.5
M6	7	10	11	15
M8	18	25	26	35
M10	37	50	52	70
M12	66	90	92	125
M14	83	112	116	158
M16	166	225	229	310
M20	321	435	450	610
M30	1,103	1 495	1,550	2 100



8.8



10.9

Hydraulic Fitting Torque

Tightening Flare Type Tube Fittings

1. Check flare and flare seat for defects that might cause leakage.
2. Align tube with fitting before tightening.
3. Hand-tighten swivel nut until snug.
4. To prevent twisting the tube, use two wrenches. Place one wrench on the connector body and tighten the swivel nut with the second. Torque to values shown.

If a torque wrench is not available, use the FFFT (Flats From Finger Tight) method.

Hydraulic Fitting Torque					
Tube Size OD	Hex Size Across Flats	Torque value		Flats From Finger Tight	
		lbf•ft	N•m	Flats	Turns
3/16	7/16	6	8	2	1/6
1/4	9/16	11–12	15–17	2	1/6
5/16	5/8	14–16	19–22	2	1/6
3/8	11/16	20–22	27–30	1-1/4	1/6
1/2	7/8	44–48	59–65	1	1/6
5/8	1	50–58	68–79	1	1/6
3/4	1-1/4	79–88	107–119	1	1/8
1	1-5/8	117–125	158–170	1	1/8

Values shown are for non-lubricated connections.