



BXT4213 Chipper Parts Manual

Prior to S/N 2E9US11138S030077



Foreword

EMB Mfg. has prepared this parts manual to assist customers in ordering quality OEM replacement parts.

Proper and regular service and replacing old, worn or broken parts with the correct Wallenstein parts are essential to prolonging the life of your Wallenstein product. Please refer to this manual before ordering any replacement parts.

All information contained in this parts manual is based on the latest product specification available at the time of printing this manual. If your product differs from the specifications contained within this manual contact EMB Mfg. for information.

EMB reserves the right to alter specifications on their products at any time.

Reproduction of this parts manual of any kind is prohibited without prior written permission from EMB Mfg.

Table of Contents

Running Gear	4
Rotor	6
Blower	7
Driveline	8
Gas, Guards & Battery	9
Discharge Chute	10
Hopper	11
Hub	12
Wiring Diagram	13
Decals	14

BXT42 RUNNING GEAR PARTS BREAKDOWN

ITEM	PART NO.	DESCRIPTION	QTY.
1	1052A101	Assembly, Trailer Tongue	1
2	1052A102	Torflex with Hub, RH	1
3	1052A103	Torflex with Hub, LH	1
4	1052W105	Wire Protector Weldment	1
5	Z61102	Oval Light 2-1/4 x 6-1/4, Red	2
6	Z61103	Oval Grommet 2-1/2 x 6.76	2
7	Z61201	Round Marker Lamp 2" Red	2
8	Z61202	Round Grommet 2" Lamp	4
9	Z61205	Round Marker Lamp 2" Amber	2
10	Z61301	License Lamp	1
11	Z71130	Hex Bolt 1/4NC x 3	2
12	Z71510	Hex Bolt 1/2NC x 1	1
13	Z71535	Hex Bolt 1/2NC x 3-1/2	1
14	Z72111	Hex Lock Nut 1/4NC	2
15	Z72221	Hex Lock Nut, 5/16NC	12
16	Z72251	Hex Lock Nut 1/2NC	2
17	Z76225	Carriage Bolt, 5/16NC x 1	12
18	Z91301	4.80-8 LRB SportTrail 3-3/4 Solid	2
ITEM	PART NO.	DESCRIPTION	QTY.
20	1052W101	Main Spine	1
21	1052W102	Jack Stand	1
22	Z12431	Snapper Pin 3/8 x 2-1/4	1
23	Z71412	Hex Bolt 7/16NC x 1-1/4	2
24	Z71530	Hex Bolt 1/2NC x 3	2
25	Z72240	Hex Lock Nut, 7/16NC	2
26	Z72251	Hex Lock Nut 1/2NC	2
27	Z73240	Wide Flat Washer 7/16	4
28	Z91614	2" Hitch Coupler	1
29	Z92303	Safety Chain 1/4 x 2'	2
ITEM	PART NO.	DESCRIPTION	QTY.
30	Z23201	L44643 Cone, L44610 Cup	2
31	Z28301	Double Lip Seal 1-1/4 Shaft	1
33	Z72931	Lug Nut 1/2NF	4
34	Z91201	1000# 4-Bolt Hub	1
35	Z91801	Dust Cap 1.98 Bore	1

Running Gear Breakdown

**Z91202 HUB ASSEMBLY - PARTS
TWO REQ'D PER UNIT**

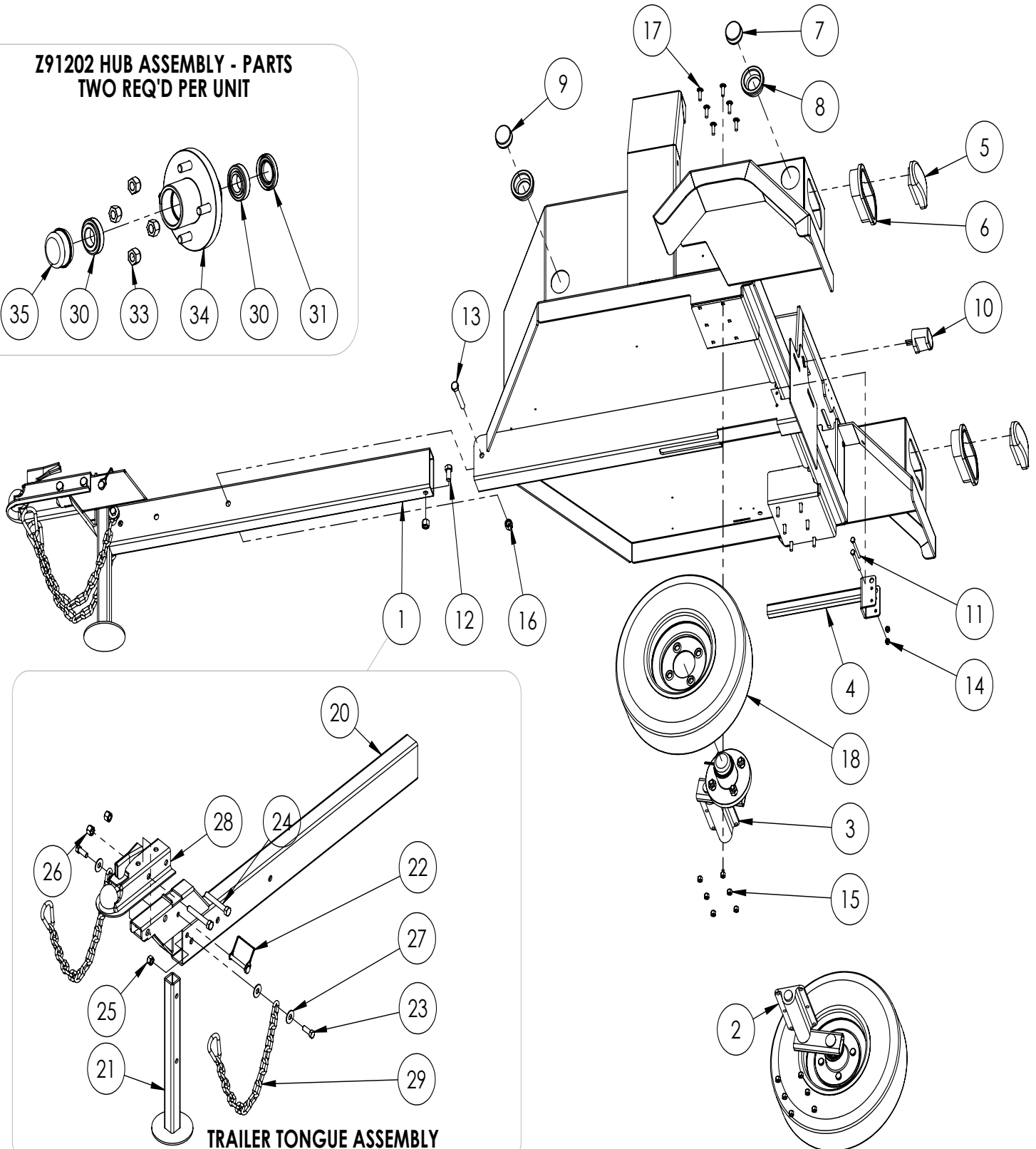
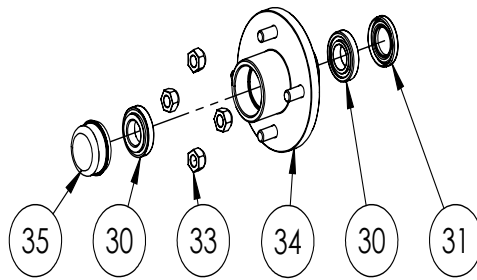

TRAILER TONGUE ASSEMBLY

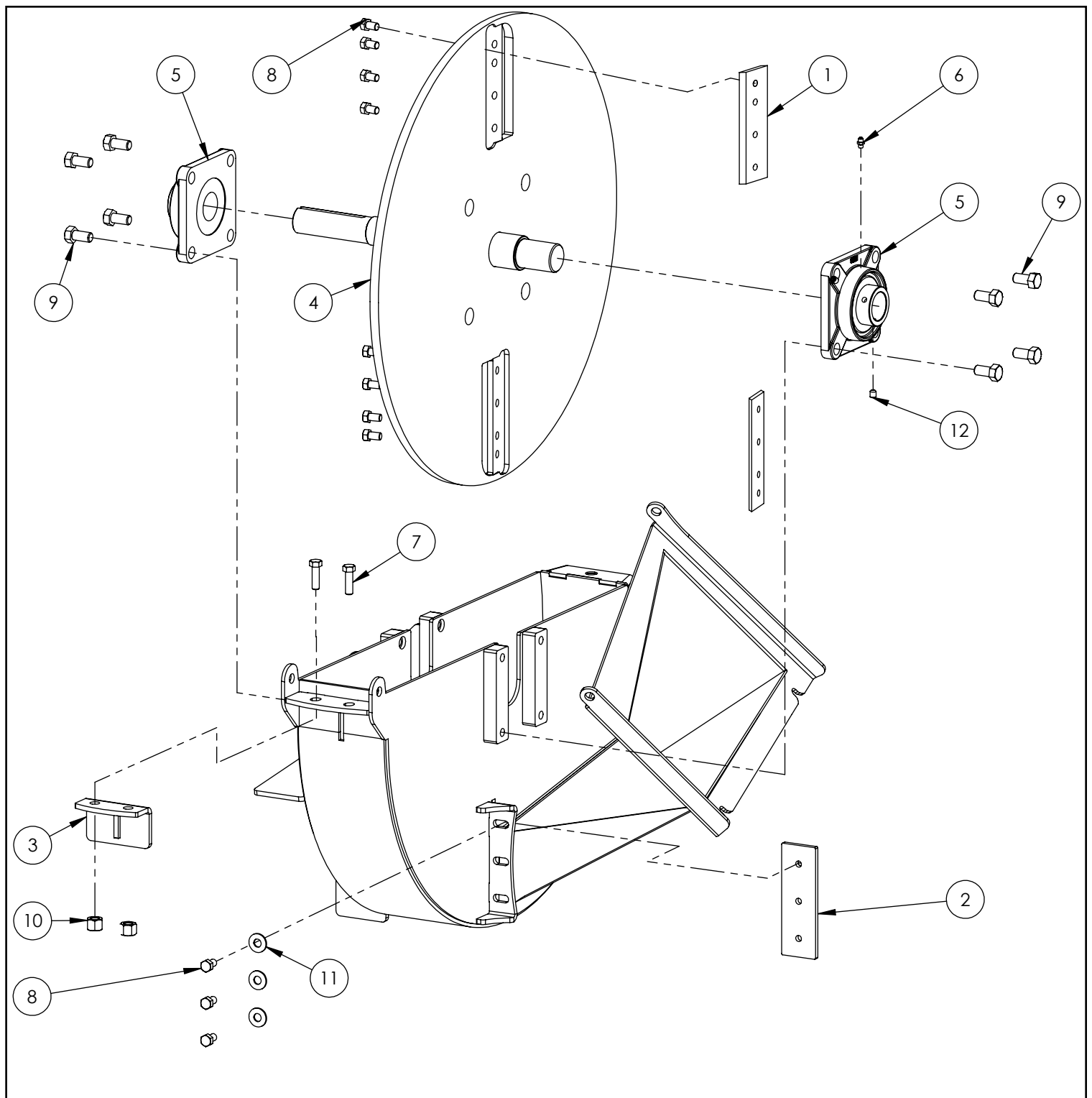

BXT42 ROTOR PARTS BREAKDOWN

ITEM	PART NO.	DESCRIPTION	QTY
1	1011M103	Knife, 4" Rotor	2
2	1011M104	Knife, 4" Ledger	1
3	1011W104	Twig Breaker	1
4	1052W293	Rotor	1
5	Z25204	4-Bolt Bearing 1-1/2" Bore	2
6	Z29202	Grease Zerk 1/4NF	2
7	Z71512	Hex Bolt 1/2NC x 1-1/4	2
8	Z71372G8	Hex Bolt, 3/8NF x 5/8 G8	11
9	Z71672G8	Hex Bolt 5/8NF x 1-3/4 G8	8
10	Z72251	Hex Lock Nut 1/2NC	2
11	Z73230	Wide Flat Washer 3/8	3
12	Z74122	Set Screw, 5/16NF	4

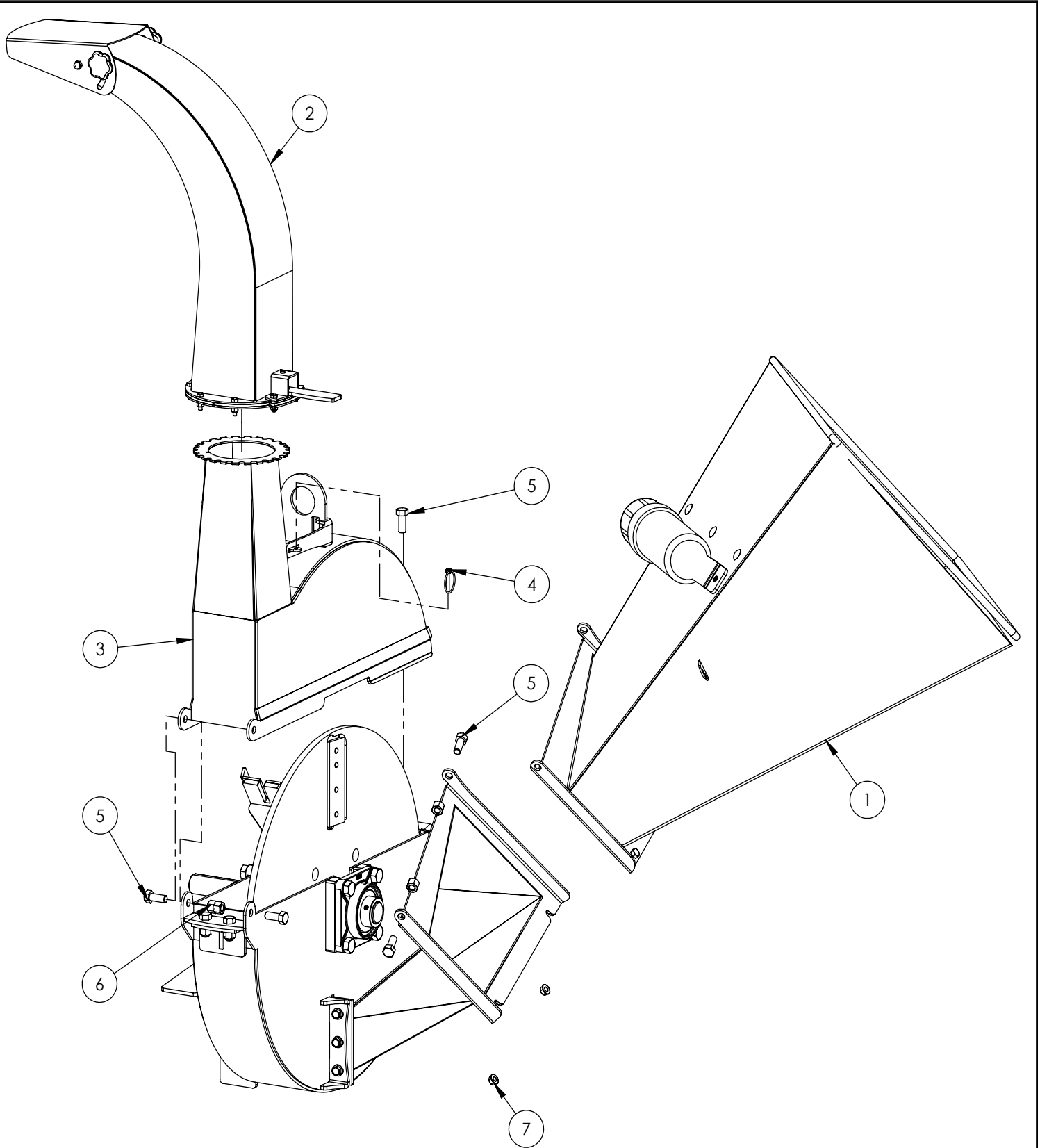

BXT42 BLOWER PARTS BREAKDOWN

ITEM	PART NO.	DESCRIPTION	QTY
1	1011A102	Self-Feed Hopper	1
2	1016A001	Assembly, Discharge Chute	1
3	1052W292	Housing, Upper Rotor	1
4	Z12110	Latch Pin 3/16	1
5	Z71512	Hex Bolt 1/2NC x 1-1/4	5
6	Z72251	Hex Lock Nut 1/2NC	4
7	Z72531	Flange Nut 3/8NC	2

BXT4213 DRIVELINE PARTS BREAKDOWN

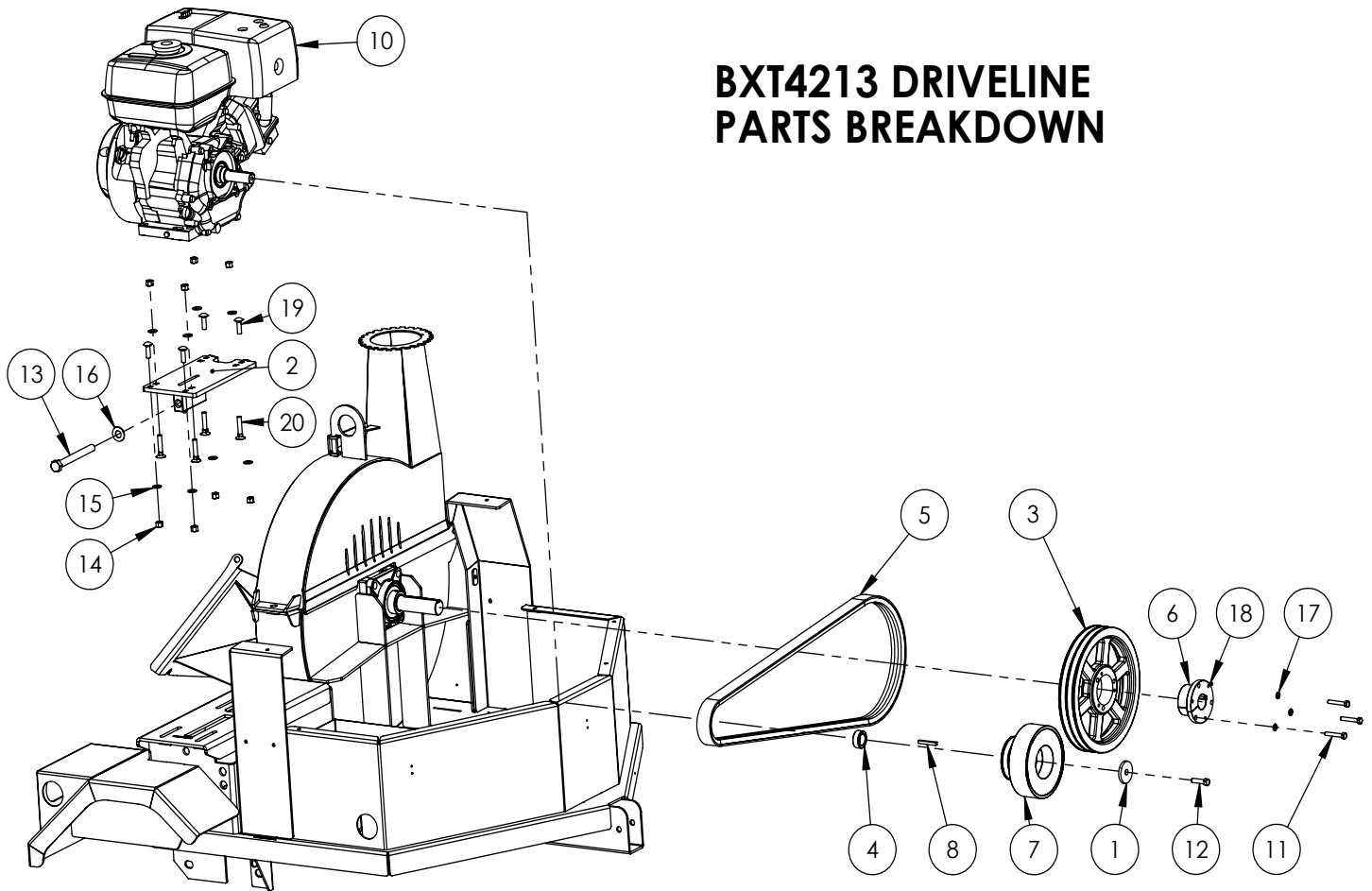

ITEM	PART NO.	DESCRIPTION	QTY
1	1052L917	Washer, Clutch Trap	1
2	1052W104	Engine Adjustment Plate	1
3	C61020	Double "B" Sheave, 11.35" Pitch	1
4	C61041	Spacer 1" ID x 0.625 w/ Keyway	1
5	Z41258	Double "B" x 74"	1
6	Z41501	SK Bushing, 1-3/8 Bore	1
7	Z41901	Clutch 1" BorexDbl"B" 3.6P	1
8	Z46531	Key 1/4 x 1/4 x 2	1
9	Z46541	Key 5/16 x 5/16 x 2	1
10	Z47146	GX390 13HP Engine	1
11	Z71220	Hex Bolt 5/16NC x 2	3
12	Z71377	Hex Bolt 3/8NF x 1-1/2	1
13	Z71660	Hex Bolt 5/8NC x 6	1
14	Z72231	Hex Lock Nut 3/8NC	8
15	Z73130	Flat Washer 3/8	8
16	Z73160	Flat Washer 5/8	1
17	Z73320	Lock Washer 5/16	3
18	Z74110	Set Screw 1/4NC	1
19	Z76232	Carriage Bolt 3/8NC x 1-1/4	4
20	Z76632	Plow Bolt 3/8NC x 2	4

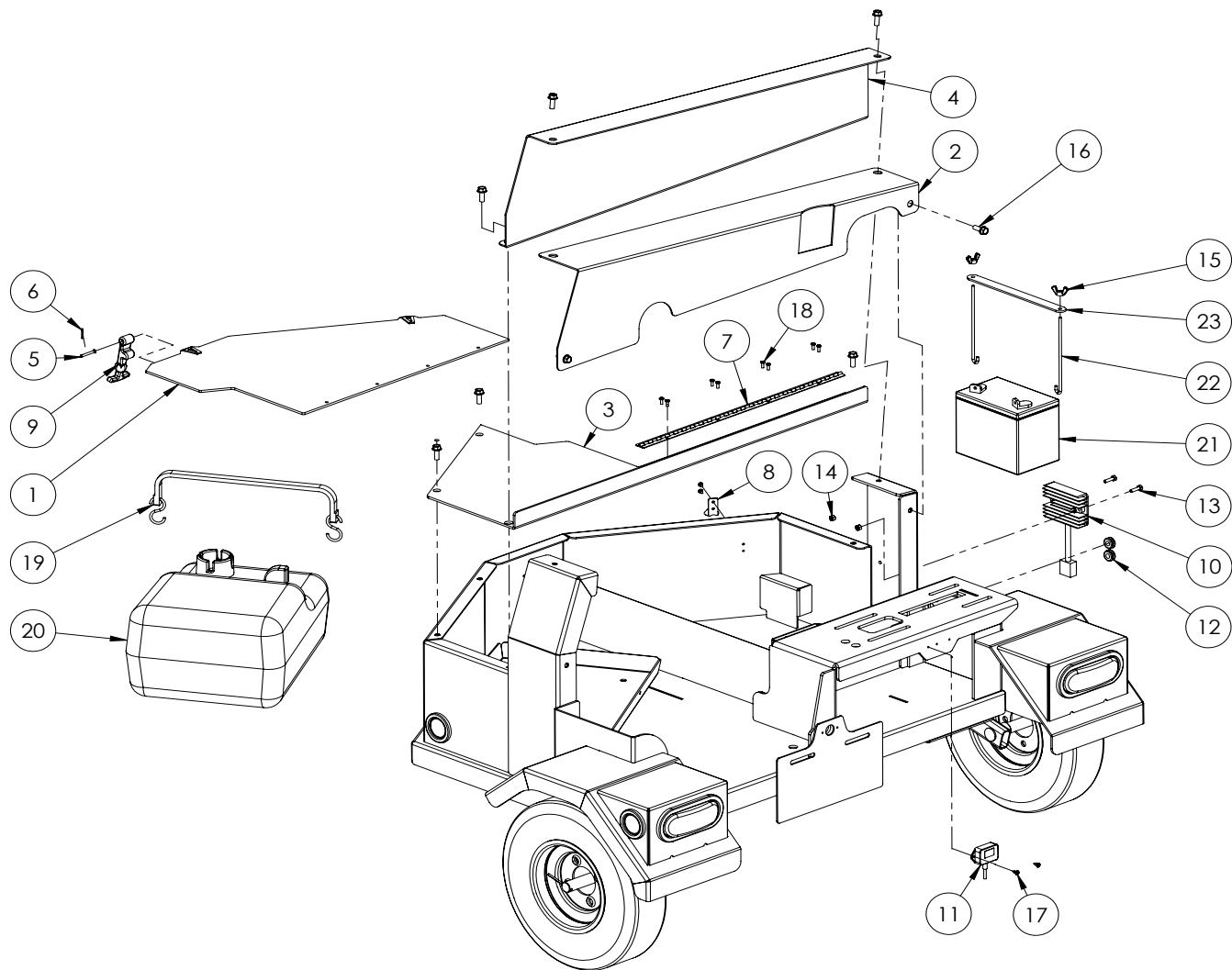

GAS, GUARDS, & BATTERY PARTS BREAKDOWN

ITEM	PART NO.	DESCRIPTION	QTY.
1	1052A104	Toolbox Lid	1
2	1052L122	Rear Belt Guard	1
3	1052L123	Tank Bay Cover	1
4	1052L125	Front Belt Guard	1
5	Z11301	Clevis Pin 3/16 x 1-3/8	2
6	Z12301	Cotter Pin 3/32 X 3/4	2
7	Z18102	.1"x1"Leafx2' Piano Hinge Stnls	1
8	Z18201-2	Top Bracket	2
9	Z18201-3	Hood Latch Strap	2
10	Z47901	Regulator Rectifier	1
11	Z47902	HONDA Hour Meter / Tach	1
12	Z62808	Rubber Grommet 7/16 x 1/4	2
13	Z71112	Hex Bolt 1/4NC x 1.25	2
14	Z72111	Hex Lock Nut 1/4NC	2
15	Z72921	Wing Nut 1/4NF	2
16	Z76134	Flange Bolt, 3/8NC x 1	8
17	Z76711	Self-tapping Screw #10	6
18	Z78303	Machine Screw #10NF x 1/2	8
19	Z92401	3/4" x 2' Bungee Strap	1
20	Z93101	25L Marine Fuel Tank	1
21	Z93201	250 CCA Battery	1
22	Z93202	J-Hook 1/4 x 7	2
23	Z93207	Hold-Down Strap, 1 x 8-1/2	1

NOTE:
Items 10, 13 & 14 are not
on the BX4213 Model

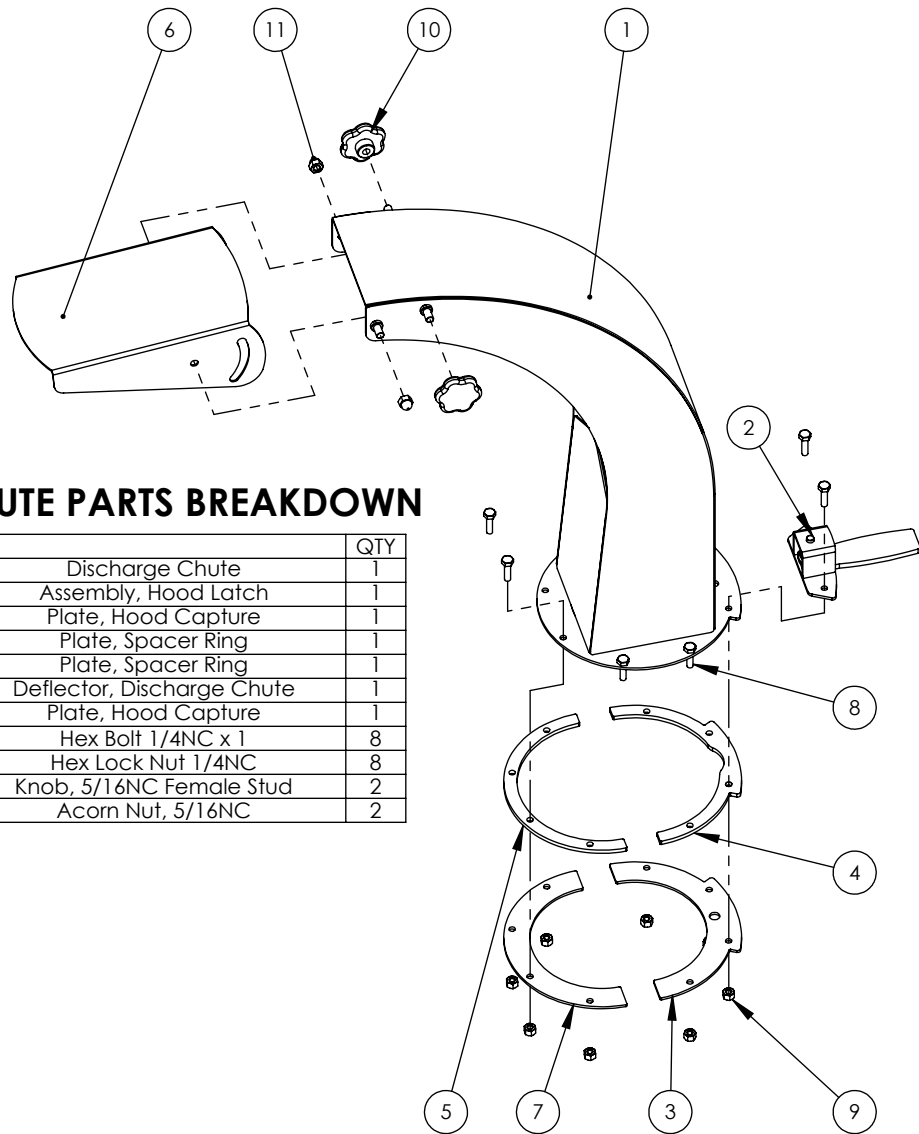

DISCHARGE CHUTE PARTS BREAKDOWN

ITEM	PART NO.		QTY
1	1016W006	Discharge Chute	1
2	1012W208	Assembly, Hood Latch	1
3	1016L030	Plate, Hood Capture	1
4	1016L029	Plate, Spacer Ring	1
5	1016L027	Plate, Spacer Ring	1
6	1016L033	Deflector, Discharge Chute	1
7	1016L034	Plate, Hood Capture	1
8	Z71110	Hex Bolt 1/4NC x 1	8
9	Z72111	Hex Lock Nut 1/4NC	8
10	Z19313	Knob, 5/16NC Female Stud	2
11	Z72914	Acorn Nut, 5/16NC	2

HOPPER PARTS BREAKDOWN

ITEM	PART NO.	DESCRIPTION	QTY
1	1011L151	Strap, Hopper Flap	1
2	1011S103	Flap, Hopper	2
3	1011W107	Weldment, Infeed Hopper	1
4	Z72231	Hex Lock Nut 3/8NC	3
5	Z76233	Carriage Bolt 3/8NC x 3/4	3
6	Z76712	Self-tapping Screw #10	3
7	Z96503	Manual Tube 3-1/2 Short	1

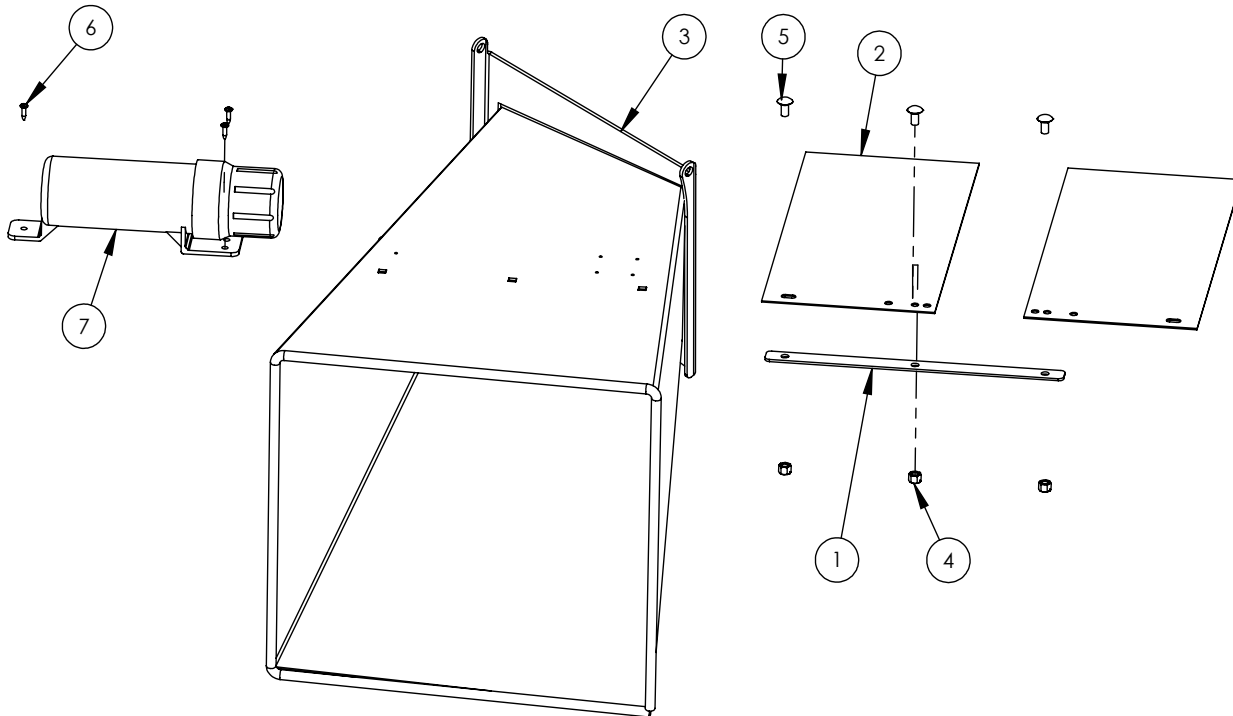

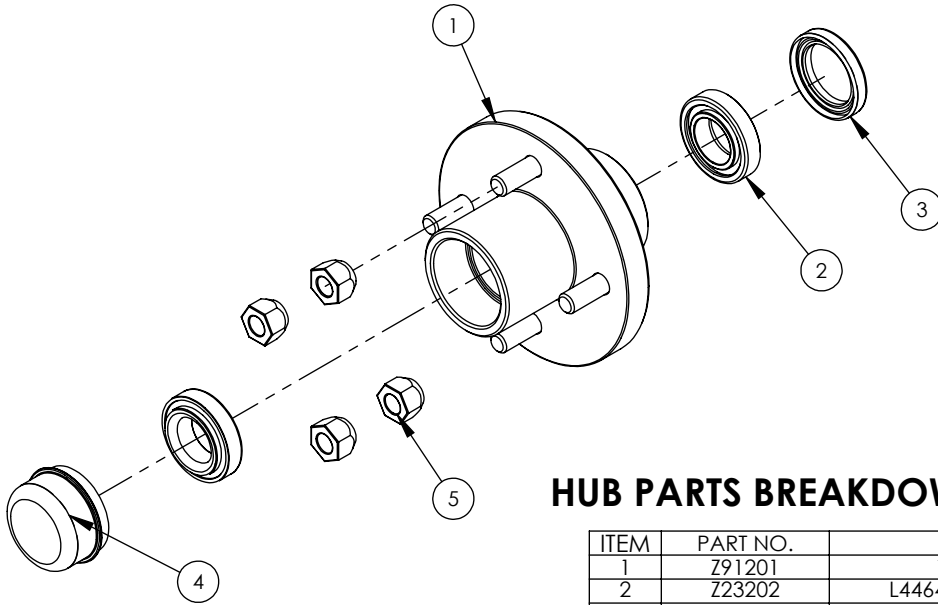

HUB PARTS BREAKDOWN (1-1/16" SPINDLE)

ITEM	PART NO.	DESCRIPTION	QTY
1	Z91201	1000# 4-Bolt Hub	1
2	Z23202	L44649 Cone, L44610 Cup	2
3	Z28302	Double Lip Seal 1-1/16 Spindle	1
4	Z91801	Dust Cap 1.98 Bore	1
5	Z72931	Lug Nut 1/2NF	4

BXT42 WIRING

RIGHT SIDE

LEFT SIDE

KEY	
Bl	- BLUE
Br	- BROWN
Gr	- GREEN
Rd	- RED
Yl	- YELLOW
Bk	- BLACK
Wh	- WHITE

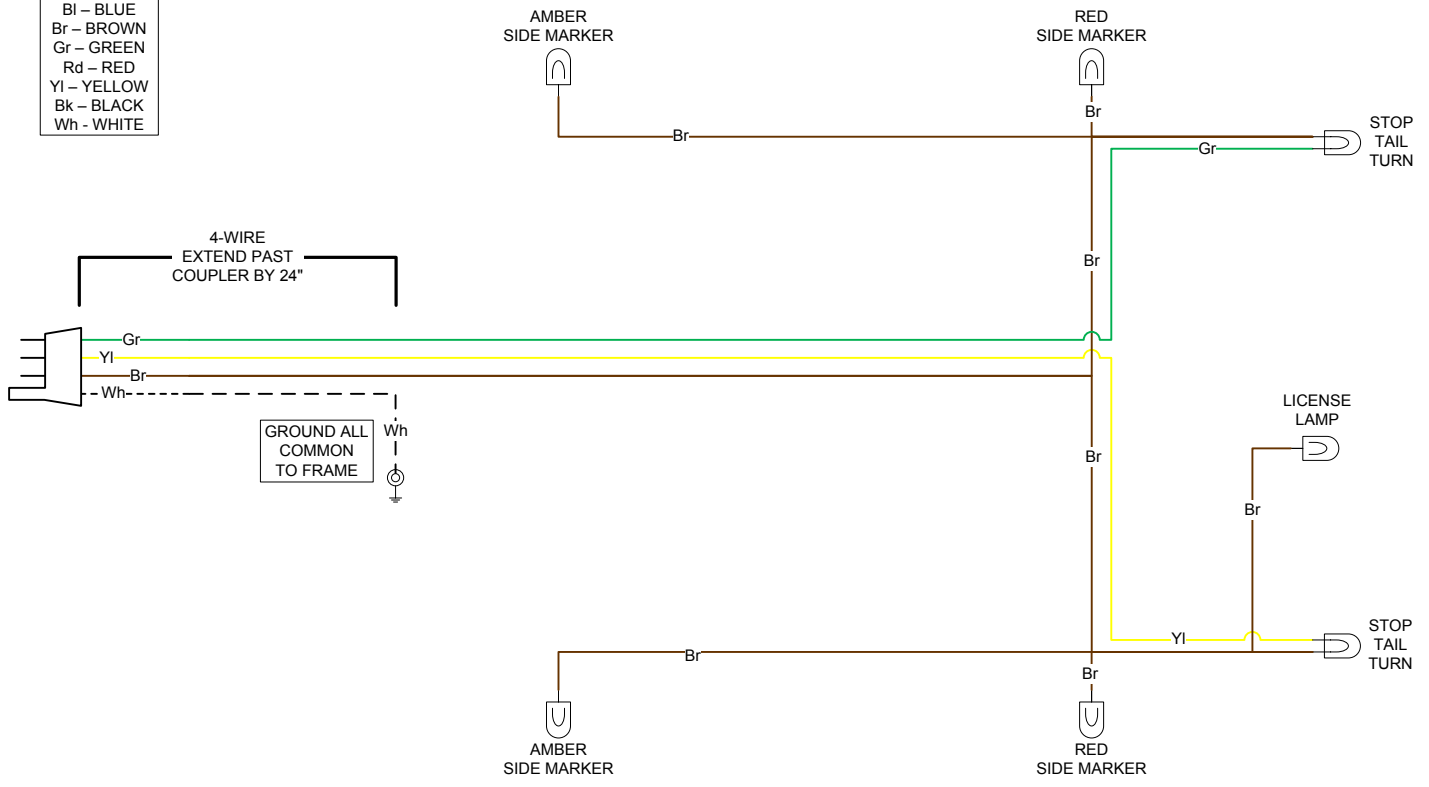

BXT4213 DECAL BREAKDOWN

ITEM	PART NO.	DESCRIPTION	QTY
1	Z94056	WALLENSTEIN Decal	3
2	Z94019	1" Dia. Made In Canada	5
3	Z94108	BXT4213 Decal	2
4	Z94007	DANGER - Rotating Blades	4
5	Z94006	CAUTION - Read Manual	1
6	Z94012	WARNING - Rotating Part Hazard	1
7	Z94008	DANGER - Thrown Object Hazard	3
8	Z94013	DANGER - Missing Guard	1

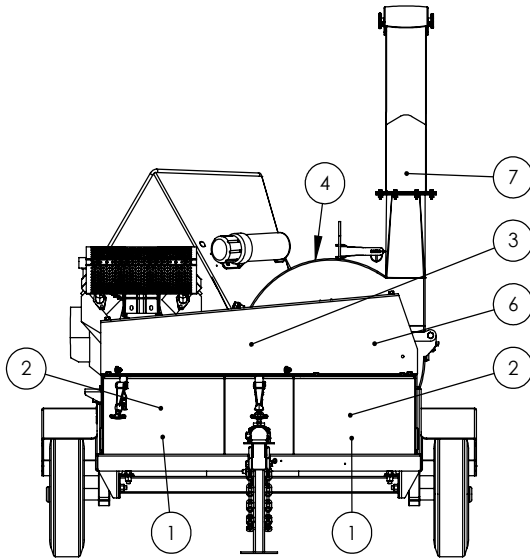

LEFT

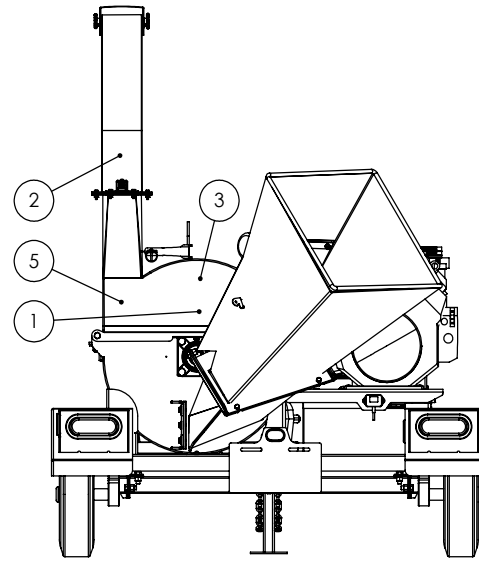

BACK

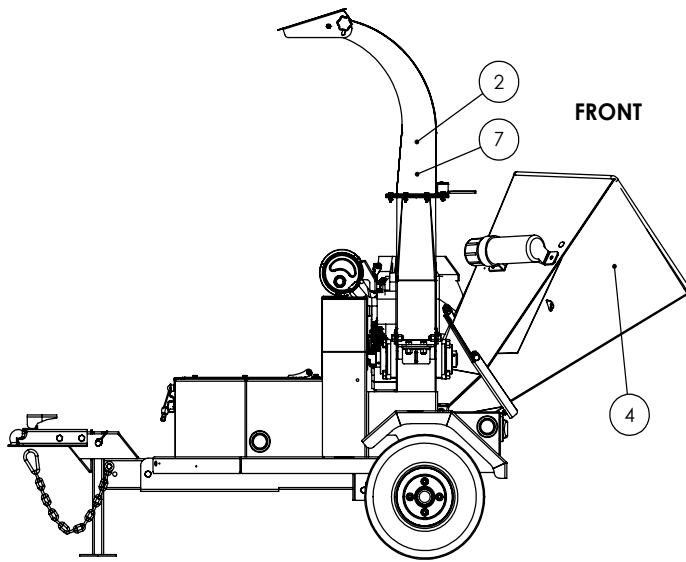

FRONT

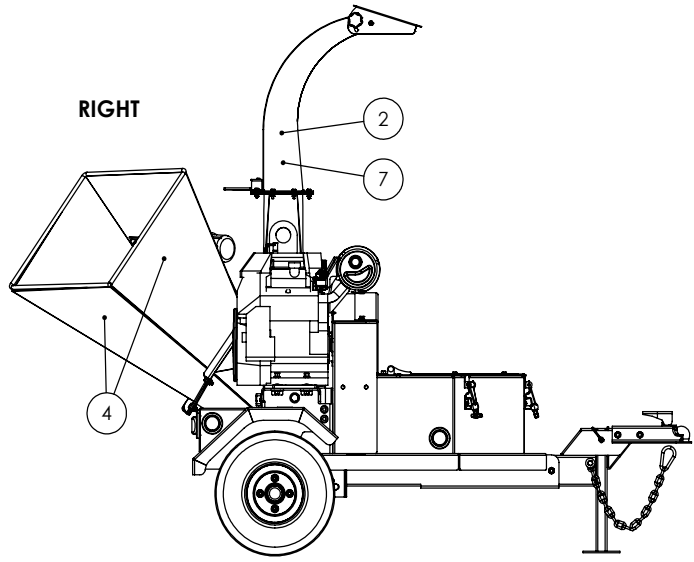

RIGHT

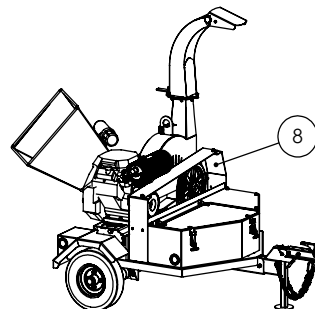

Decals BXT4213

Z94056



Z94108



Z94006

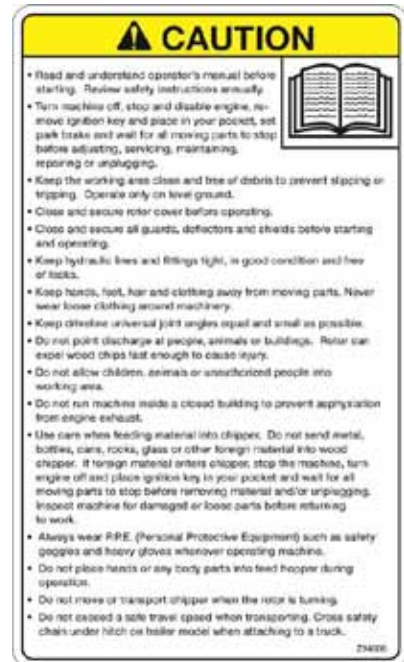

Z94019



Z94007



Z94013



Z94012



Z94008





WALLENSTEIN Products Manufactured by:

EMB MFG Inc.

4144 Boomer Line
St. Clements, Ontario
Canada N0B 2M0
Phone: 1-877-695-9283
Fax: 519-699-4146
www.embmfg.com