

WALLENSTEIN

BY EMB MFG INC.

EMB Manufacturing Inc.
4144 Boomer Line · St. Clements, On · N0B 2M0 · Canada
Ph: (519) 699-9283 · Fax: (519) 699-4146
www.embmfg.com



WP830

WP630



WP860

Wood Processor MODEL WP630, WP830 & WP860

OPERATOR'S MANUAL

TABLE OF CONTENTS

WARRANTY	3	4.6	ATTACHING AND UNHOOKING	28
INSPECTION REPORT	4	4.7	MACHINE SET-UP	29
SERIAL NUMBER LOCATION	5	4.8	FIELD OPERATION	32
1 INTRODUCTION	6	4.8.1.	PREPARE	32
2 SAFETY	7	4.8.2.	STARTING PROCEDURE:	33
2.1 GENERAL SAFETY	8	4.8.3.	STOPPING PROCEDURE:	33
2.2 EQUIPMENT SAFETY GUIDELINES	9	4.8.4.	EMERGENCY STOPPING:	33
2.3 SAFETY SIGNS	9	4.8.5.	PROCESSING OPERATION:	34
2.4 SAFETY TRAINING	10	4.8.6.	PULL ANGLE:	36
2.5 PREPARATION	10	4.8.7.	WOOD DISCHARGE:	36
2.6 MAINTENANCE SAFETY	11	4.8.8.	LOG CHAIN OR STRAP:	36
2.7 HYDRAULIC SAFETY	11	4.8.9.	CUTTING:	37
2.8 TRANSPORT SAFETY	11	4.8.10.	SPLITTING:	37
2.9 OPERATING SAFETY	12	4.9	TRANSPORTING	38
2.10 STORAGE SAFETY	13	4.10	STORAGE	39
2.11 REFUELLING SAFETY	13	4.10.1	PLACING IN STORAGE	39
2.12 BATTERY SAFETY	13	4.10.2	REMOVING FROM STORAGE	39
2.13 TIRE SAFETY	13	5 SERVICE AND MAINTENANCE	40	
2.14 GAS MOTOR SAFETY	14	5.1	SERVICE	40
3 SAFETY SIGN LOCATIONS	16	5.1.1	FLUIDS AND LUBRICANTS	40
4 OPERATION	17	5.1.2	GREASING	40
4.1 TO THE NEW OPERATOR OR OWNER ...	18	5.1.3	SERVICE ILLUSTRATION	41
4.2 MACHINE COMPONENTS	19	5.1.4	HYDRAULIC OIL FILTER & CHANGE ..	43
4.3 MACHINE BREAK-IN	20	6 TROUBLE SHOOTING	43	
4.4 PRE-OPERATION CHECKLIST	20	6.1	TROUBLE SHOOTING CHART.....	44
4.5 CONTROLS	21	7 SPECIFICATIONS	45	
4.5.1. GAS ENGINE ELECTRIC START	21	7.1	MECHANICAL	45
4.5.2. GAS ENGINE MANUAL START	22	7.2	BOLT TORQUE	46
4.5.3. HYDRAULIC WINCH CONTROL	23	7.3	HYDRAULIC FITTING TORQUE	47
4.5.4. WINCH GEAR LEVER:	23	8 ACCESSORIES	48	
4.5.5. CONTROLS & AUTO CYCLE	24	#2089A570	NYLON CHAINSAW HOLSTER ...	48
4.5.6. SPLITTING WEDGE HEIGHT LEVER:	26	#2089W571	6-WAY WEDGE	48
4.5.7. ADJUSTABLE LOG LENGTH GUIDE:	26	#299001	48" LOG PEAVEY	48
4.5.8. SPLITTER CHUTE HEIGHT ADJUSTER: ..	27	9 INDEX	49	



WARRANTY

Effective on products retailed on or after January 1, 2015.

**Register your product online at www.embmfg.com
within 30 days of purchase to activate warranty.**

This product is warranted to be free of defects in materials and workmanship under normal use and service, for a period of

**Five (5) Years for Consumer
Two (2) Year for Commercial/Rental**

from the date of purchase, when operated and maintained in accordance with the Operating and Maintenance Instructions supplied with this unit. Warranty is limited to the repair of the product and/or replacement of parts.

This warranty does not cover the following items:

- 1) Machines or parts lost or damaged during shipment,
- 2) Normal maintenance or adjustments after initial pre-service and set up is completed
- 3) Normal replacement of service items.
- 4) Accessory items / parts not supplied by EMB MFG INC.
- 5) Damages resulting from:
 - misuse, negligence, accident, theft or fire
 - use of improper or insufficient fuel, fluids or lubricants
 - use of parts or after market accessories other than genuine EMB MFG INC. parts
 - modifications, alteration, tampering or improper repair performed by parties other than an authorized dealer
 - any device or accessories installed by parties other than an authorized EMB dealer or distributor

Engines are covered by the manufacturer of the engine and covered by the warranty period specified by that manufacturer.

Engine warranty must be registered at the engine manufactures website. For service contact your local engine dealer.

Under no circumstances will the manufacturer be liable for any consequential damage or expense of any kind, including loss of profits. The manufacturer is under no circumstances liable for tow vehicle of any kind. The manufacturer is not liable for the maintenance of the product.

This warranty is extended only to the original purchaser and is not transferable. Warranty is void if repairs are attempted by anyone other than a Wallenstein Authorized Service Centre.

If a difficulty develops with the product, contact the local dealer from which you purchased the unit. Only Wallenstein authorized dealers are authorized to make repairs to the product or affect the replacement of defective parts, which will be done at no charge within a reasonable time after the receipt of the product. Unit or parts shall be returned at the customer's expense to the Authorized Service Centre. Damage in transit is not covered by warranty. Include the original purchase receipt with any claim (keep a copy of the receipt for your files).

The distributor's liability under warranty is limited to the repair of the product and/or replacement of parts and is given to the purchaser in lieu of all other remedies including incidental and consequential charges. There are no warranties, expressed or implied, other than those specified herein.

EMB MFG Inc
4144 Boomer Line, St Clements, ON N0B 2M0 Canada
Phone: 519-699-9283 Fax: 519-699-4146 : attention to Warranty Dept
Email: warranty@embmfg.com

WALLENSTEIN
Wood Processor

INSPECTION REPORT

This form must be filled out by the dealer and signed by both the dealer and the customer at the time of delivery.

Customer's Name _____	Dealer Name _____
Address _____	Address _____
City, State/Province, Code _____	City, State/Province, Code _____
Phone Number (____) _____	Phone Number (____) _____
Contact Name _____	
Model _____	
Serial Number _____	

DEALER INSPECTION REPORT

SAFETY

- ___ Check Condition of Rope
- ___ Fasteners Tight
- ___ Lubricate Machine
- ___ Check for Hydraulic Leaks
- ___ Check that Cylinder Extends Freely
- ___ Retainers Installed Through Drawbar Pin or Ball Mechanism
- ___ Check Tire Pressure
- ___ Check Engine Fluid Levels
- ___ Check Hydraulic Reservoir Level

- ___ Safety Chain on Hitch
- ___ All Decals Installed
- ___ Guards and Shields Installed and Secured
- ___ Review Operating and Safety Instructions

Delivery Date _____

I have thoroughly instructed the buyer on the above described equipment which review included the Operator's Manual content, equipment care, adjustments, safe operation and applicable warranty policy.

Date _____

Dealer's Rep. Signature _____

The above equipment and Operator's Manual have been received by me and I have been thoroughly instructed as to care, adjustments, safe operation and applicable warranty policy.

Date _____

Owner's Signature _____

To activate warranty, register your product online at www.embmfg.com

SERIAL NUMBER LOCATION

Always give your dealer the serial number of your Wallenstein Wood Processor when ordering parts or requesting service or other information.

The serial number plate is located where indicated. Please mark the number in the space provided for easy reference.



Location (Typical)

SERIAL NUMBER LOCATION

Wood Processor Serial Number _____

Model Number _____

1 INTRODUCTION

Congratulations on your choice of a Wallenstein Wood Processor to compliment your operation. This equipment has been designed and manufactured to meet the needs of a discerning timber or woodlot industry.

Safe, efficient and trouble free operation of your Wallenstein Wood Processor requires that you and anyone else who will be using or maintaining the Wood Processor, read and understand the Safety, Operation, Maintenance and Trouble Shooting information contained within the Operator's Manual.

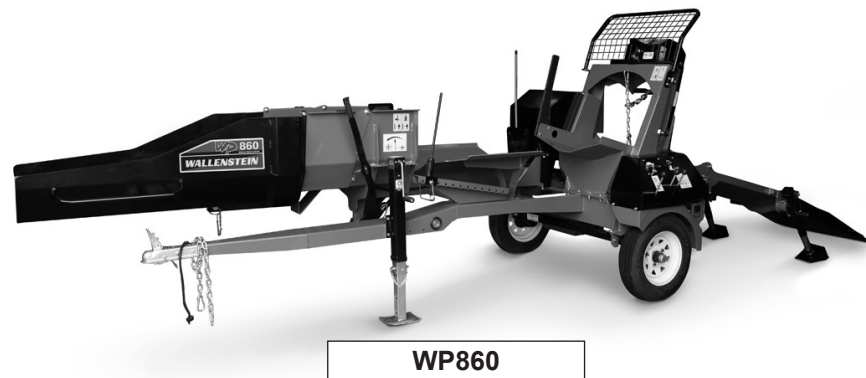
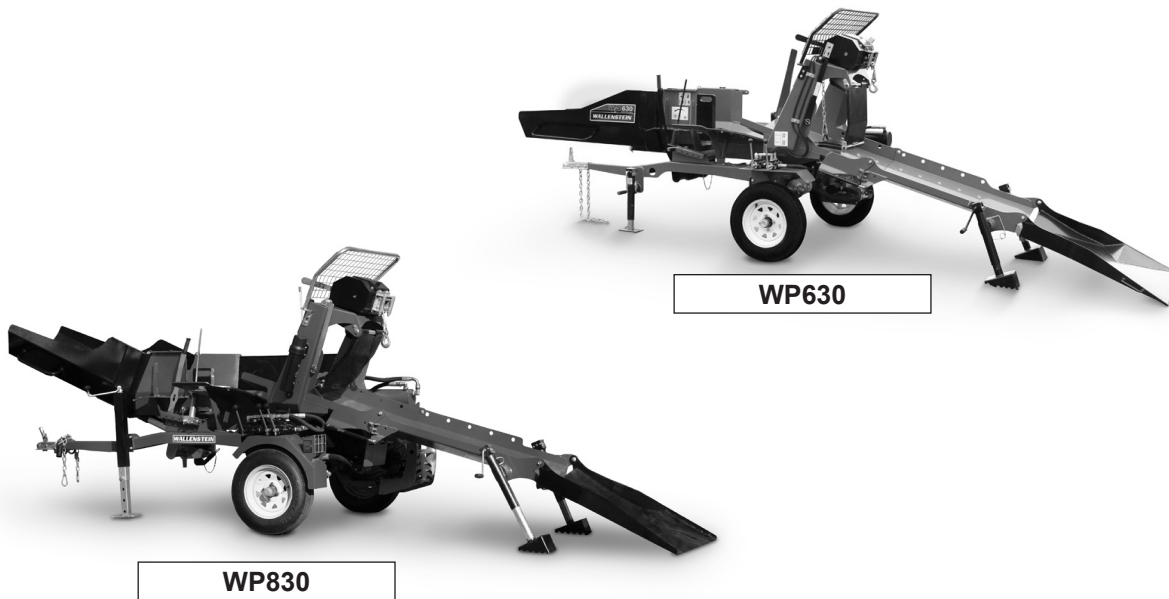

This manual covers the Wallenstein Wood Processor Model WP630, WP830 & WP860. Use the Table of Contents or Index as a guide to locate required information.

Keep this manual handy for frequent reference and to pass on to new operators or owners. Call your Wallenstein dealer or the Distributor if you need assistance, information or additional copies of the manuals.

OPERATOR ORIENTATION - When describing controls, the directions left, right, back and forward, as mentioned throughout this manual, are determined when standing at the control panel. Otherwise, the hitch is the front of the machine and the control panel is on the left side.

2 SAFETY

SAFETY ALERT SYMBOL

This Safety Alert symbol means **ATTENTION! BECOME ALERT! YOUR SAFETY IS INVOLVED!**



The Safety Alert symbol identifies important safety messages on the Wallenstein Wood Processor and in the manual. When you see this symbol, be alert to the possibility of personal injury or death. Follow the instructions in the safety message.

Why is SAFETY important to you?

3 Big Reasons

Accidents Disable and Kill
Accidents Cost
Accidents Can Be Avoided

SIGNAL WORDS:

Note the use of the signal words **DANGER**, **WARNING** and **CAUTION** with the safety messages. The appropriate signal word for each message has been selected using the following guide-lines:

DANGER - Indicates an imminently hazardous situation that, if not avoided, will result in death or serious injury. This signal word is to be limited to the most extreme situations typically for machine components which, for functional purposes, cannot be guarded.

WARNING - Indicates a potentially hazardous situation that, if not avoided, could result in death or serious injury, and includes hazards that are exposed when guards are removed. It may also be used to alert against unsafe practices.

CAUTION - Indicates a potentially hazardous situation that, if not avoided, may result in minor or moderate injury. It may also be used to alert against unsafe practices.

If you have any questions not answered in this manual or require additional copies or the manual is damaged, please contact your dealer or Wallenstein, 4144 Boomer Line, St. Clements, ON, N0B 2M0. Phone (519) 699-9283 or Fax (519) 699-4146.

SAFETY

YOU are responsible for the SAFE operation and maintenance of your Wallenstein Wood Processor. **YOU** must ensure that you and anyone else who is going to use, maintain or work around the Wood Processor be familiar with the using and maintenance procedures and related **SAFETY** information contained in this manual. This manual will take you step-by-step through your working day and alerts you to all good safety practices that should be used while using the Wood Processor.

Remember, **YOU** are the key to safety. Good safety practices not only protect you but also the people around you. Make these practices a working part of your safety program. Be certain that **EVERYONE** using this equipment is familiar with the recommended using and maintenance procedures and follows all the safety precautions. Most accidents can be prevented. Do not risk injury or death by ignoring good safety practices.

- Wood Processor owners must give operating instructions to operators or employees before allowing them to operate the machine, and at least annually thereafter.
- The most important safety device on this equipment is a **KNOWLEDGEABLE SAFE** operator. It is the operator's responsibility to read and understand ALL Safety and Operating instructions in the manual and to follow them. Most accidents can be avoided.
- A person who has not read and understood all using and safety instructions **is not qualified** to use the machine. An untrained operator exposes himself and bystanders to possible serious injury or death.
- Do not modify the equipment in any way. Unauthorized modification may impair the function and/or safety and could affect the life of the equipment.
- Think SAFETY! Work SAFELY!

2.1 GENERAL SAFETY

1. Read and understand the Operator's Manual and all safety signs before using, maintaining, adjusting or cleaning the Wood Processor.



2. Have a first-aid kit available for use should the need arise and know how to use it.



3. Have a fire extinguisher available for use should the need arise and know how to use it.



4. Do not allow riders.

5. Wear appropriate protective gear. This list includes but is not limited to:

- A hard hat
- Protective shoes with slip resistant soles
- Protective goggles or face shield
- Heavy gloves
- Wet weather gear
- Hearing Protection
- Respirator or filter mask



6. Install and secure all guards before starting.

7. Wear suitable ear protection for prolonged exposure to excessive noise.

8. Move controls to neutral or off position, stop engine, remove ignition key and wait for all moving parts to stop before attempting any service, repair or maintenance.



9. Clear the area of people, especially small children, before using the unit.

10. Review safety related items annually with all personnel who will operating or maintaining the Wood Processor.

2.2 EQUIPMENT SAFETY GUIDELINES

1. Safety of the operator and bystanders is one of the main concerns in designing and developing equipment. However, every year many accidents occur which could have been avoided by a few seconds of thought and a more careful approach to handling equipment. You, the operator, can avoid many accidents by observing the following precautions in this section. To avoid personal injury or death, study the following precautions and insist those working with you, or for you to follow them.
2. In order to provide a better view, certain photographs or illustrations in this manual may show an assembly with a safety shield removed. However, equipment should never be used in this condition. Keep all shields in place. If shield removal becomes necessary for repairs, replace the shield prior to use.
3. Replace any safety sign or instruction sign that is not readable or is missing. Location of such safety signs is indicated in this manual.
4. Never use alcoholic beverages or drugs which can hinder alertness or coordination while using this equipment. Consult your doctor about using this machine while taking prescription medications.
5. **Under no circumstances should young children be allowed to work with this equipment. Do not allow persons to use or assemble this unit until they have read this manual and have developed a thorough understanding of the safety precautions and of how it works.** Review the safety instructions with all users annually.
6. This equipment is dangerous to children and persons unfamiliar with its operation. The operator should be a responsible, properly trained and physically able person familiar with machinery and trained in this equipment's operations. If the elderly are assisting with work, their physical limitations need to be recognized and accommodated.
7. Never exceed the limits of a piece of machinery. If its ability to do a job, or to do so safely, is in question - **DON'T TRY IT.**
8. Do not modify the equipment in any way. Unauthorized modification may result in serious injury or death and may impair the function and life of the equipment.
9. In addition to the design and configuration of this implement, including Safety Signs and Safety Equipment, hazard control and accident prevention are dependent upon the awareness, concern, prudence, and proper training of personnel involved in the operation, transport, maintenance, and storage of the machine. Refer also to Safety Messages and operation instruction in each of the appropriate sections of the engine and machine manuals. Pay close attention to the Safety Signs affixed to the engine and the machine.

2.3 SAFETY SIGNS

1. Keep safety signs clean and legible at all times.
2. Replace safety signs that are missing or have become illegible.
3. Replaced parts that displayed a safety sign should also display the current sign.
4. Safety signs displayed in Section 3 each have a part number in the lower right hand corner. Use this part number when ordering replacement parts.
5. Safety signs are available from your authorized Distributor or Dealer Parts Department or the factory.

How to Install Safety Signs:

- Be sure that the installation area is clean and dry.
- Be sure temperature is above 50°F (10°C).
- Determine exact position before you remove the backing paper.
- Remove the smallest portion of the split backing paper.
- Align the sign over the specified area and carefully press the small portion with the exposed sticky backing in place.
- Slowly peel back the remaining paper and carefully smooth the remaining portion of the sign in place.
- Small air pockets can be pierced with a pin and smoothed out using the piece of sign backing paper.

2.4 SAFETY TRAINING

1. Safety is a primary concern in the design and manufacture of our products. Unfortunately, our efforts to provide safe equipment can be wiped out by a single careless act of an operator or bystander.
2. In addition to the design and configuration of equipment, hazard control and accident prevention are dependent upon the awareness, concern, prudence and proper training of personnel involved in the operation, transport, maintenance and storage of this equipment.

3. It has been said, "The best safety feature is an informed, careful operator." We ask you to be that kind of an operator. It is the operator's responsibility to read and understand ALL Safety and Using instructions in the manual and to follow these. Accidents can be avoided.

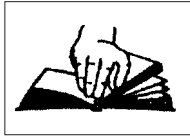

4. **Working with unfamiliar equipment can lead to careless injuries. Read this manual before assembly or using, to acquaint yourself with the machine. If this machine is used by any person other than yourself, or is loaned or rented, it is the machine owner's responsibility to make certain that the operator, prior to using:**

- a. **Reads and understands the operator's manuals.**
- b. **Is instructed in safe and proper use.**

5. Know your controls and how to stop engine and machine quickly in an emergency. Read this manual and the one provided with engine.
6. Train all new personnel and review instructions frequently with existing workers. Be certain only a properly trained and physically able person will use the machinery. A person who has not read and understood all using and safety instructions is not qualified to use the machine. An untrained operator exposes himself and bystanders to possible serious injury or death. If the elderly are assisting with the work, their physical limitations need to be recognized and accommodated.

2.5 PREPARATION

1. Never use the machine until you have read and completely understand this manual, the engine Operator's Manual and each of the Safety Messages found on the safety signs on the engine and machine.

2. Personal protection equipment including hard hat, safety glasses, safety shoes, and gloves are recommended during assembly, installation, operation, adjustment, maintaining, repairing, removal, cleaning, or moving the unit. Do not allow long hair, loose fitting clothing or jewellery to be around equipment.



3. **PROLONGED EXPOSURE TO LOUD NOISE MAY CAUSE PERMANENT HEARING LOSS!**

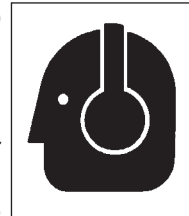

- Power equipment with or without equipment attached can often be noisy enough to cause permanent, partial hearing loss. We recommend that you wear hearing protection on a full-time basis if the noise in the Operator's position exceeds 80db. Noise over 85db on a long-term basis can cause severe hearing loss. Noise over 90db adjacent to the Operator over a long-term basis may cause permanent, total hearing loss. **NOTE:** Hearing loss from loud noise (from engines, chain saws, radios, and other such sources close to the ear) is cumulative over a lifetime without hope of natural recovery.
4. Clear working area of stones, branches or hidden obstacles that might be hooked or snagged, causing injury or damage.
 5. Use only in daylight or good artificial light.
 6. Be sure machine is properly mounted, adjusted and in good operating condition.
 7. Ensure that all safety shielding and safety signs are properly installed and in good condition.

2.6 MAINTENANCE SAFETY

1. Good maintenance is your responsibility. Poor maintenance is an invitation to trouble.
2. Follow good shop practices.

- Keep service area clean and dry.
- Be sure electrical outlets and tools are properly grounded.
- Use adequate light for the job at hand.



3. Make sure there is plenty of ventilation. Never operate the engine of the engine in a closed building. The exhaust fumes may cause asphyxiation.
4. Before working on this machine, shut off the engine, set the brake or chock the wheels, and turn fuel valve off.
5. Never work under equipment unless it is blocked securely.
6. Always use personal protection devices such as eye, hand and hearing protectors, when performing any service or maintenance work. Use heavy or leather gloves when handling rope or wood.
7. Where replacement parts are necessary for periodic maintenance and servicing, genuine factory replacement parts must be used to restore your equipment to original specifications. The manufacturer will not be responsible for injuries or damages caused by use of unapproved parts and/or accessories.
8. A fire extinguisher and first aid kit should be kept readily accessible while performing maintenance on this equipment.

9. Periodically tighten all bolts, nuts and screws and check that all electrical and fuel connections are properly secured to ensure unit is in a safe condition.



10. When completing a maintenance or service function, make sure all safety shields and devices are installed before placing unit in service.

2.7 HYDRAULIC SAFETY

1. Make sure that all the components in the hydraulic system are kept in good condition and are clean.
2. Before applying pressure to the system, make sure all components are tight, and that lines, hoses and couplings are not damaged.
3. Do not attempt any makeshift repairs to the hydraulic lines, fittings or hoses by using tapes, clamps or cements. The hydraulic system operates under extremely high pressure. Such repairs will fail suddenly and create a hazardous and unsafe condition.
4. Wear proper hand and eye protection when searching for a high pressure hydraulic leak. Use a piece of wood or cardboard as a backstop instead of hands to isolate and identify a leak.
5. If injured by a concentrated high-pressure stream of hydraulic fluid, seek medical attention immediately. Serious infection or toxic reaction can develop from hydraulic fluid piercing the skin surface.
6. Relieve pressure on hydraulic system before maintaining or working on system.

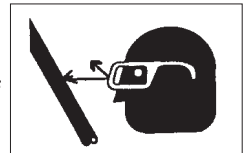

2.8 TRANSPORT SAFETY

1. Comply with provincial or state and local laws governing safety and transporting of machinery on public roads.
2. Check that all the lights, reflectors and other lighting requirements are installed and in good working condition.
3. Do not exceed a safe travel speed. Slow down for rough terrain and cornering.
4. Be sure the Wood Processor is hitched positively to the tow unit with retainers installed through the drawbar pin or hitch coupler mechanism.
5. Always install transport locks, pins or brackets before transporting.
6. Plan your route to avoid heavy traffic.
7. Do not drink and drive.
8. Be a safe and courteous driver. Always yield to oncoming traffic in all situations, including narrow bridges, intersections, etc. Watch for traffic when operating near or crossing roadways.
9. Never allow riders on the machine.

2.9 OPERATING SAFETY

1. Please remember it is important that you read and heed the safety signs on the Wood Processor. Clean or replace all safety signs if they cannot be clearly read and understood. They are there for your safety, as well as the safety of others. The safe use of this machine is strictly up to you, the operator.
2. All things with moving parts are potentially hazardous. There is no substitute for a cautious, safe-minded operator who recognizes potential hazards and follows reasonable safety practices. The manufacturer has designed this Wood Processor to be used with all its safety equipment properly attached, to minimize the chance of accidents. Study this manual to make sure you have all safety equipment attached.
3. Close and secure all guards, deflectors and shields before starting and operating. If guard is removed, replace it.
4. Read and understand operator's manual before starting. Review safety instructions annually.
5. Personal protection equipment including hearing protection, hard hat, safety glasses, safety shoes, and gloves are recommended during assembly, installation, operation, adjustment, maintaining, repairing, removal, or moving. Do not allow long hair, loose-fitting clothing, or jewellery to be around moving parts.
6. Do not allow anyone within 20 ft (6 m) of machine or logs during operation. Wood chips can be ejected and injure others. Keep children away.
7. Move controls to neutral or off position, stop engine, remove ignition key and wait for all moving parts to stop before servicing, repairing or maintaining.
8. Do not try to process more than one log at a time. The extra log can be ejected and cause injury.
9. Keep your fingers and hands away from cracks in the log that can open or close while splitting.
10. Always handle logs by holding onto the sides, not the top and bottom.
11. Do not load the splitting cradle while the wedge is in motion.
12. Do not try to split logs across the grain. Some logs can burst or splinter and fly out of the machine causing injury.
13. For unevenly cut logs, always place the wide end down and the most square end against the splitting wedge.
14. Never stand directly in line with rope while winching.
15. Check rope condition before using winch. Rope may break during operation if it is cut, knotted, has broken strands or worn. Replace rope if damaged in any way.
16. Do not touch rope during operation.
17. Operators should never use alcoholic beverages or drugs which can hinder alertness or coordination while operating this equipment. Consult your doctor about operating this machine while taking prescription medications.
18. Operate only on level ground.
19. Do not exceed winching angle of more than $\pm 25^\circ$.
20. Always winch up a slope.
21. Do not winch across a slope.
22. Do not operate on hillsides or when working area is cluttered, wet, muddy or icy to prevent slipping and tripping.
23. Use care when pulling logs from a pile for splitting as they can roll when attaching rope or winching toward Wood Processor.
24. Position machine so prevailing winds blow engine exhaust fumes away from operator's station.
25. Keep working area clean and free of debris to prevent tripping. Operate only on level ground.
26. Stop engine when leaving the machine unattended.
27. Do not exceed a safe travel speed when transporting.
28. Read the chain saw operator's manual and follow all safety instructions.

2.10 STORAGE SAFETY

1. Store the unit in an area away from human activity.
2. Do not let children to play on or around the stored machine.
3. Store the unit in a dry, level area. Support the frame with planks if required.

2.11 REFUELLING SAFETY

1. Handle fuel with care. It is highly flammable.
2. Allow engine to cool for 5 minutes before refuelling. Clean up spilled fuel before restarting engine.
3. Do not refuel the machine while smoking or when near open flame or sparks.
4. Fill fuel tank outdoors.
5. Prevent fires by keeping machine clean of accumulated trash, grease and debris.
6. Be sure to stop the engine prior to refuelling.
7. Do not overfill the fuel tank.
8. If fuel is spilt, wipe it away carefully and wait until the fuel has dried before starting the engine.
9. After refueling, make sure that the fuel cap is secured to prevent spillage.



2.12 BATTERY SAFETY

1. Batteries generate hydrogen gas, which can be highly explosive. Do not smoke or allow flames or sparks near a battery, especially during charging.
2. Battery electrolyte contains sulphuric acid. Protect your eyes, skin and clothing. In case of contact, flush thoroughly with water and get prompt medical attention, especially if your eyes are affected.
3. Wear safety glasses when working near batteries.
4. Do not tip batteries more than 45°, to avoid electrolyte loss.
5. To avoid injury from spark or short circuit, disconnect battery ground cable before servicing any part of the electrical system.
6. Charge the battery in a fully ventilated location.
7. Be sure to confirm Battery polarity.

2.13 TIRE SAFETY

1. Failure to follow proper procedures when mounting a tire on a wheel or rim can produce an explosion which may result in serious injury or death.
2. Do not attempt to mount a tire unless you have the proper equipment and experience to do the job.
3. Have a qualified tire dealer or repair service perform required tire maintenance.
4. When replacing worn tires, make sure they meet the original tire specifications. Never undersize.

2.14 GAS MOTOR SAFETY

BEFORE STARTING ENGINE, READ AND UNDERSTAND THE OPERATING AND MAINTENANCE INSTRUCTIONS THAT CAME WITH YOUR ENGINE.

WARNING: DO NOT

1. DO NOT run engine in an enclosed area. Exhaust gases contain carbon monoxide, an odourless and deadly poison.
2. DO NOT place hands or feet near moving or rotating parts.
3. DO NOT store, spill, or use gasoline near an open flame, or devices such as a stove, furnace, or water heater which use a pilot light or devices which can create a spark.
4. DO NOT refuel indoors where area is not well ventilated. Outdoor refuelling is preferred.
5. DO NOT refuel while engine is running. Allow engine to cool for 5 minutes before refuelling. Store fuel in approved safety containers.
6. DO NOT remove fuel tank cap while engine is running.
7. DO NOT operate engine if gasoline is spilled. Move machine away from the spill and avoid creating any ignition until gasoline has evaporated.
8. DO NOT smoke while filling fuel tank.
9. DO NOT choke carburettor to stop engine. Whenever possible, gradually reduce engine speed before stopping.
10. DO NOT run engine above rated speeds. This may result in injury.
11. DO NOT tamper with governor springs, governor links or other parts which may increase the governed speed.
12. DO NOT tamper with the engine speed selected by the original equipment manufacturer.
13. DO NOT check for spark with spark plug or spark plug wire removed.
14. DO NOT crank engine with spark plug removed. If engine is flooded, crank until engine starts.
15. DO NOT strike flywheel with a hard object or metal tool as this may cause flywheel to shatter in operation. Use proper tools to service engine.
16. DO NOT operate engine without a muffler. Inspect periodically and replace, if necessary. If engine is equipped with a muffler deflector, inspect periodically and replace, if necessary with correct deflector.
17. DO NOT operate engine with an accumulation of grass, leaves, dirt or other combustible materials in the muffler area.
18. DO NOT use this engine on any forest covered, brush covered, or grass covered unimproved land unless a spark arrester is installed on the muffler. The arrester must be maintained in effective working order by the operator. In the state of California the above is required by law (Section 4442 of the California Public Resources Code). Other states may have similar laws. Federal laws apply on federal land.
19. DO NOT touch hot muffler, cylinder or fins because contact may cause burns.
20. DO NOT run engine with air cleaner or air cleaner cover removed.

WARNING: DO

1. ALWAYS DO remove the wire from the spark plug when servicing the engine or equipment to prevent accidental starting. Disconnect the negative wire from the battery terminal if equipped with a 12 volt starting system.
2. DO keep cylinder fins and governor parts free of grass and other debris which can affect engine speed.
3. DO examine muffler periodically to be sure it is functioning effectively. A worn or leaking muffler should be repaired or replaced as necessary.
4. DO use fresh gasoline. Stale fuel can gum carburettor and cause leakage.
5. DO check fuel lines and fittings frequently for cracks or leaks. Replace if necessary.

3 SAFETY SIGN LOCATIONS

The types of safety signs and locations on the equipment are shown in the illustrations that follow. Good safety requires that you familiarize yourself with the various safety signs, the type of warning and the area, or particular function related to that area, that requires your SAFETY AWARENESS.

- Think SAFETY! Work SAFELY!

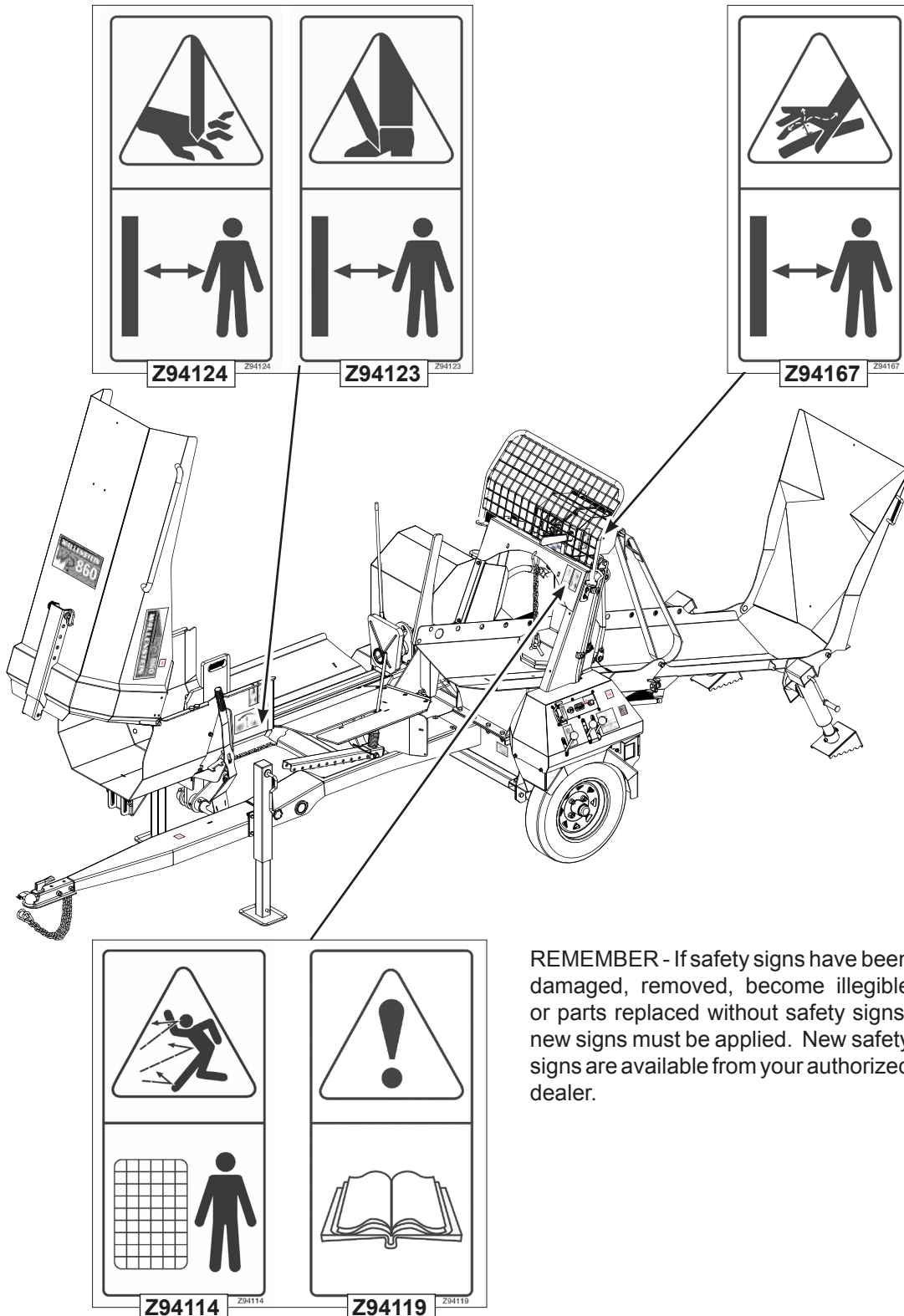

REMEMBER - If safety signs have been damaged, removed, become illegible or parts replaced without safety signs, new signs must be applied. New safety signs are available from your authorized dealer.

4 OPERATION



OPERATING SAFETY

- Read and understand operator's manual before starting. Review safety instructions annually.
- Close and secure all guards, deflectors and shields before starting and operating.
- Do not allow anyone within 20 ft (6 m) of machine or logs during operation. Wood chips can be ejected and injure others. Keep children away.
- Move controls to neutral or off position, stop engine, remove ignition key and wait for all moving parts to stop before servicing, repairing or maintaining.
- Do not try to process more than one log at a time. The extra log can be ejected and cause injury.
- Keep your fingers and hands away from cracks in the log that can open while splitting.
- Always load logs by holding onto the sides, not the top and bottom.
- Do not load the processor while the wedge is in motion.
- Do not try to split logs across the grain. Some logs can burst or splinter and fly out of the machine causing injury.
- For unevenly cut logs, always place the wide end down and the most square end against the splitting wedge.
- Never stand directly in line with rope while pulling.
- Do not touch rope during operation.
- Check rope condition before using winch. Rope may break during operation if it is cut, knotted, has broken strands or worn. Replace rope if damaged.
- Never use alcoholic beverages or drugs which can hinder alertness or coordination while operating this equipment. Consult your doctor about operating this machine while taking prescription medications.
- Operate only on level ground.
- Do not exceed winching angle of more than $\pm 25^\circ$.
- Always winch up a slope. Do not winch across a slope.
- Do not operate on hillsides or when working area is cluttered, wet, muddy or icy to prevent slipping and tripping.
- Use care when pulling logs from a pile for splitting as they can roll when attaching rope or winching toward wood processor.
- Position machine so prevailing winds blow engine exhaust fumes away from operator's station.
- Keep working area clean and free of debris to prevent tripping. Operate only on level ground.
- Stop engine when leaving unattended.
- Do not exceed a safe travel speed when transporting.
- Read the chain saw operator's manual and follow all safety instructions.

OPERATOR ORIENTATION - When describing controls, the directions left, right, back and forward, as mentioned throughout this manual, are determined when standing at the control panel.

4.1 TO THE NEW OPERATOR OR OWNER

The Wallenstein Wood Processors are designed to connect to and pull logs to the machine, position for cutting with a chain saw and split the resulting log. The operator should be familiar with the machine prior to starting.

It is the responsibility of the owner or operator to read this manual and to train all other operators before they start working with the machine. Follow all safety instructions exactly. Safety is everyone's business. By following recommended procedures, a safe working environment is provided for the operator, bystanders and the area around the work site. Untrained operators are not qualified to use the machine.

Safety:

Follow all safety instructions exactly. Safety is everyone's business. By following recommended procedures, a safe working environment is provided for the operator, bystanders and the area around the work site. Untrained operators are not qualified to operate the machine.

Many features incorporated into this machine are the result of suggestions made by customers like you. Read this manual carefully to learn how to use the winch, chain saw and wood splitter safely and how to set it to provide maximum operating efficiency. By following the instructions in conjunction with a good maintenance program, your Wood Processor will provide many years of trouble-free service.

Training:

Each operator must be trained in the proper set-up and operating procedures prior to being allowed to operate the machine.

- a. Review control location, function and movement directions.
- b. Move the unit to a large open area to allow the operator to become familiar with control function and machine response.
- c. When a new operator is familiar and comfortable with the machine, they can proceed with the work. Do not allow untrained operators to use the machine. They can endanger themselves and others or damage property and the machine.

Job Site:

It is the responsibility of the operator to be thoroughly familiar with the work site prior to starting. Prevent the chance or possibility of problems or accidents by not being in the situation to start with. Some items the operators should check include but are not limited to:

- a. Close or cramped work space. Be sure there is sufficient space and clearance for the machine to winch-in the log during operation.
- b. Organize the working area to minimize the winching and wood removal distances. The shorter the distances, the faster the work will be finished.
- c. Use care when pulling logs from a pile for splitting as they can roll when attaching the rope or winching toward the splitter.
- d. Position the machine so prevailing winds blow engine exhaust fumes away from operator's station.

Equipment Condition:

Check the general condition of the Wood Processor. Ensure that all nuts and bolts are secure and that a moveable parts are secured and in their proper place.

Always inspect the rope as it is pulled out of the winch. Do not use the machine if the rope is cut, frayed, worn or knotted. Any problem can result in early failure and create an unsafe operating condition. Replace damaged rope before resuming work.

Inspect hydraulic hoses and connections, ensure they are not damaged and or leaking.

Each machine is equipped with a safety screen that protects the operator from debris when winching. Always keep it in good condition when operating.

4.2 MACHINE COMPONENTS

The Wallenstein Wood Processor consists of a winch mounted in a frame to winch logs into the log lead in chute and then position the log on the log loader chute, up to the log length guide. The hydraulic winch control lever engages the winch motor to wind or unwind the rope. The winch control lever is spring-loaded and will return to its NEUTRAL position when the lever is released. The winch gear lever on the winch engages and disengages the gear on the winch drum. Disengaging the drum allows it to "freewheel" so the rope is easily pulled out.

The operator uses the saw guide to safely align the chain saw to cut the log to the desired length. When the log is cut, it rolls onto the splitting cradle.

Engaging the hydraulic splitter levers causes the hydraulic cylinder to push the log through the 4-way wedge.

The Push block locator indicates to the operator where the push block is at all times.

Power to drive the machine is provided through the gas engine and hydraulic pump.

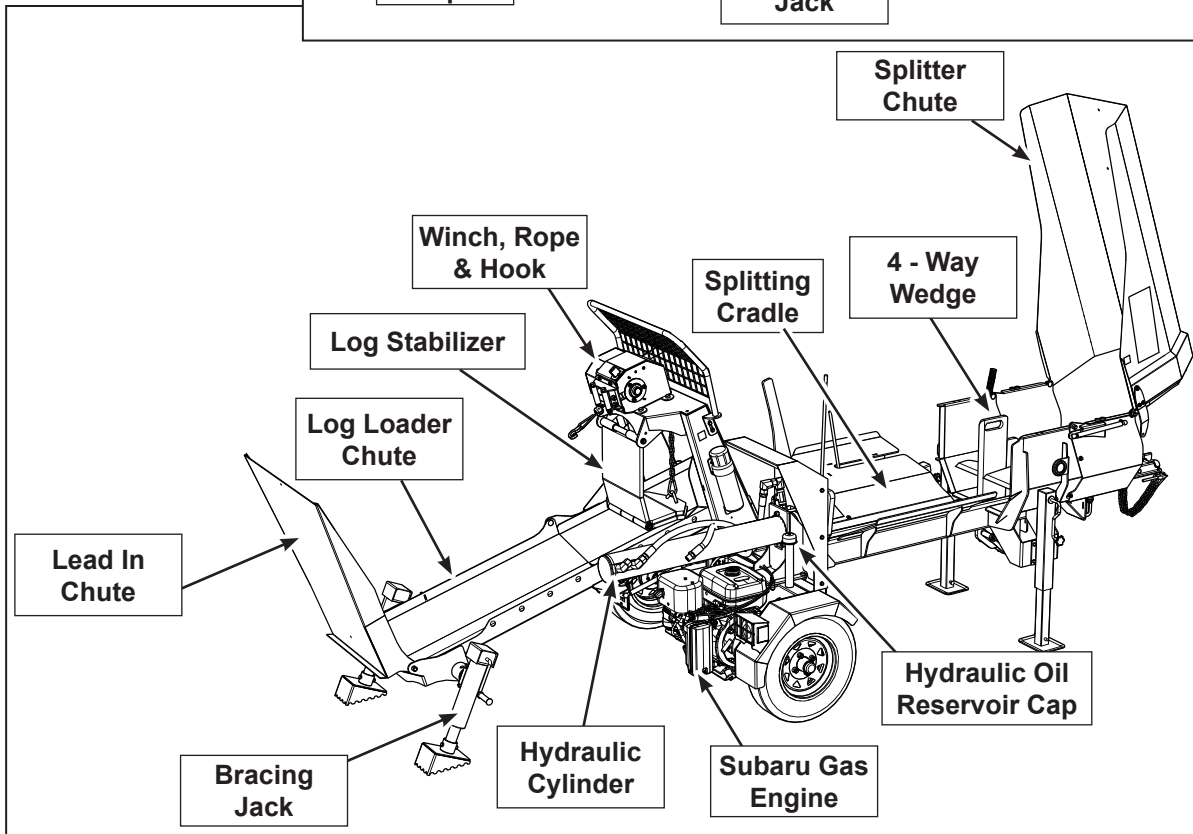
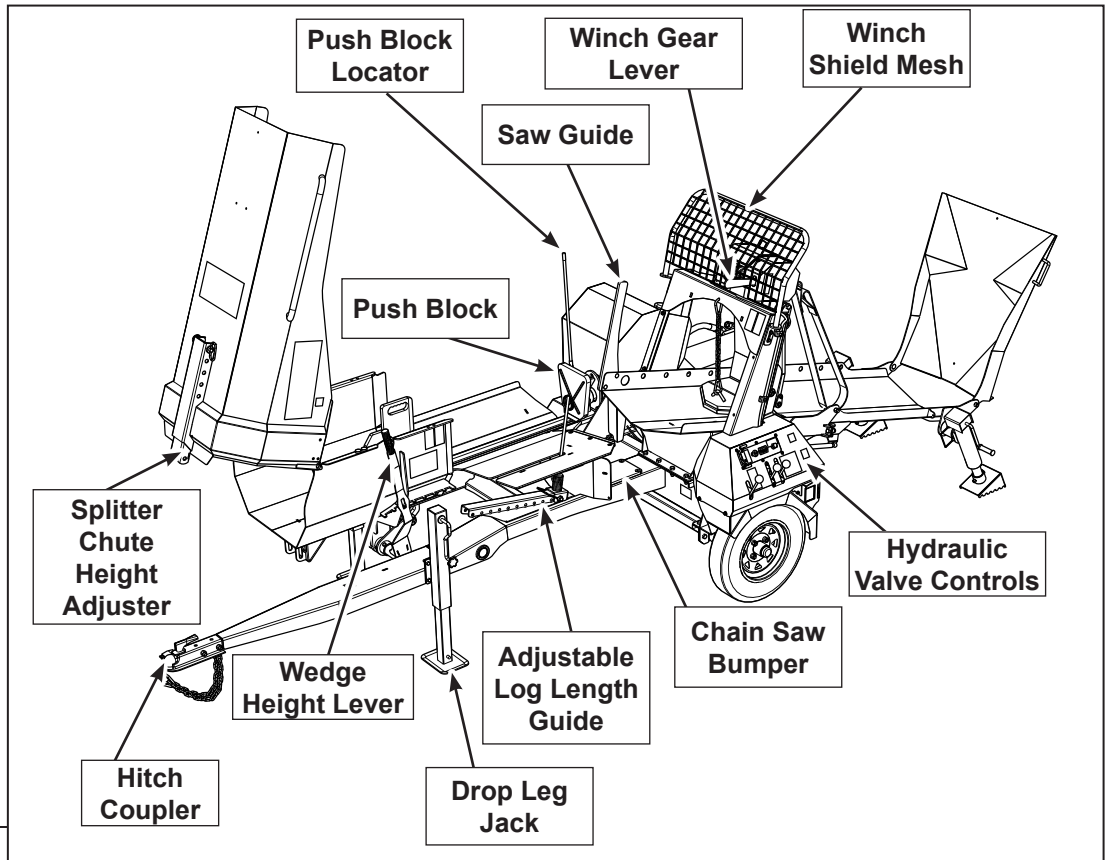

Fig. 1 PRINCIPLE COMPONENTS

4.3 MACHINE BREAK-IN

Although there are no operational restrictions on the Wood Processor when used for the first time, it is recommended that the following mechanical items be checked:

A. After operating for 1 to 5 hours:

1. Check all nuts, bolts and other fasteners. Tighten to their specified torque.
2. Check hydraulic system for leaks. Tighten all leaking fittings and replace any leaking components.
3. Check machine fluid levels: Fuel, engine oil, and hydraulic oil reservoir. Top up as required.
4. Check condition of winch.
5. Check the condition of the rope. Replace if cut, knotted, worn or if it has any broken strands.
6. Check for entangled material. Remove all entangled material before resuming work.
7. Lubricate all grease fittings.

B. After operating for 20 hours:

1. Repeat steps 1 through 7 listed above. (Section A)
2. Change engine oil after 20 hours.
3. Go to the normal servicing and maintenance schedule as defined in the Maintenance Section.

4.4 PRE-OPERATION CHECKLIST

Efficient and safe operation of the Wallenstein Wood Processor requires that each operator reads and understands the using procedures and all related safety precautions outlined in this section. A pre-operation checklist is provided for the operator. It is important for both the personal safety and maintaining good mechanical condition that this checklist is followed.

Before operating the Wood Processor and each time thereafter, the following areas should be checked off:

1. Lubricate the machine per the schedule outline in the Maintenance Section.
2. Check for entangled material. Remove any twine, wire, chips or other material that has become entangled.
3. Check the condition of the winch rope. Replace cut, knotted, worn or if it has any broken strands. Replace rope if damaged.
4. Check the wedge and block. Inspect for damaged or broken components and excessive wear. Lubricate, repair or replace as required.
5. Check for hydraulic leaks. Tighten fittings or replace components to stop leaks.
6. Check engine and machine fluid levels. Top up as required.
7. Check that all bearings turn freely. Replace any that are rough or seized.
8. Make sure that all guards and shields are in place, secured and functioning as designed.
9. Check the condition of the winch. It must be in good condition to operate properly.

4.5 CONTROLS

Before starting to work, all operators should familiarize themselves with the location and function of controls.

4.5.1. GAS ENGINE ELECTRIC START

(Models WP830 & WP860):

Read the engine manufacturers operator's manual before starting for more detailed instructions.

a. **Ignition Switch:**

This key operated switch controls the electrical system power to the engine.

OFF Turn key fully counter-clockwise to stop the electrical system power and turn the engine off.

ON Turn clockwise to detent at the on position. This is the position where the engine will continue to run.

START Turn fully clockwise to the last spring-loaded detent position to engage the starter solenoid and start the engine. Release the key when the engine starts and it will return to the RUN position.

b. **Choke:**

This push/pull knob controls the position of the choke. Pull the knob out to close the choke for starting when the engine is cold. Push the knob in to open the choke as the engine warms. Always push the knob fully in when operating the machine. Refer to the engine owners manual for complete starting details.

c. **Throttle:**

This lever controls the engine RPM. Push the lever up to increase engine speed and down to decrease.

d. **Fuel Shut-Off Valve:**

This valve controls the flow of fuel to the engine. Turn the valve at right angles to the fuel line to turn the fuel off and parallel to turn the fuel on.

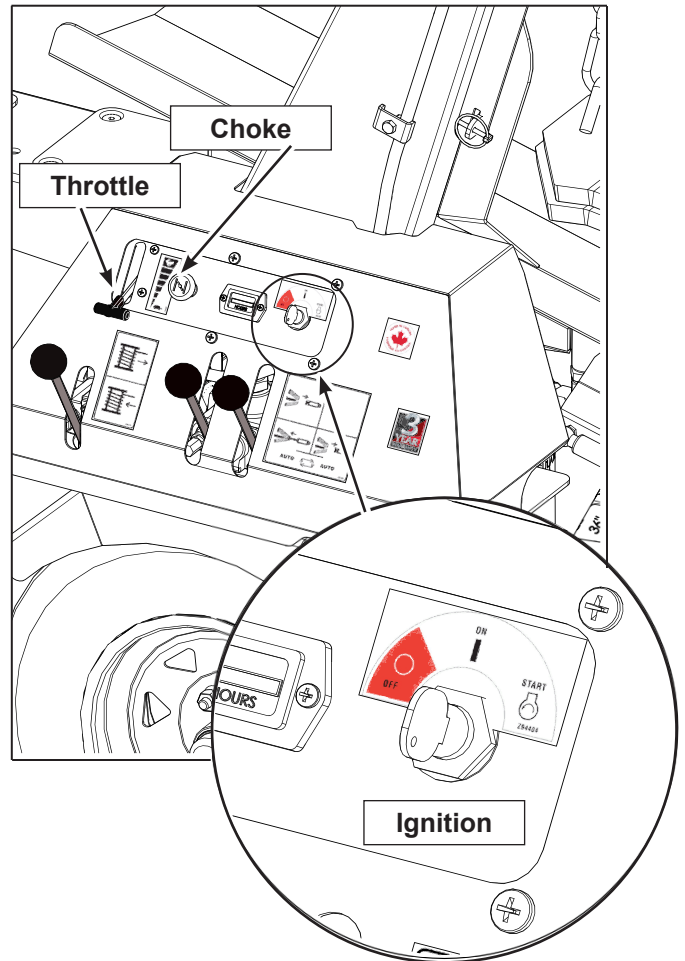

Fig. 2 CONTROLS: WP830 & WP860

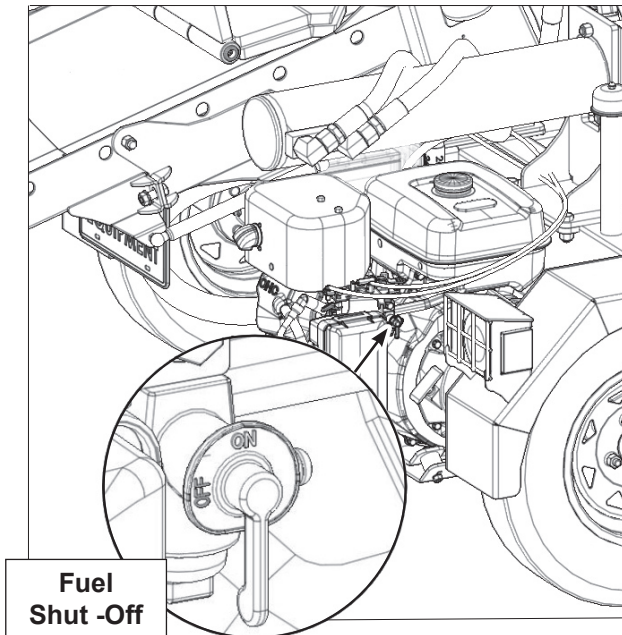

Fig. 3 WP830 & WP860: SUBARU EX40 14HP

4.5.2. GAS ENGINE MANUAL START

(Model WP 630):

Read the engine manufacturers operator's manual before starting for more detailed instructions.

a. **Ignition Switch:**

This switch controls the electrical power to the engine electrical system. Turn the switch counter-clockwise to turn OFF. Turn clockwise to the first position to turn ON.

b. **Choke:**

This lever controls the position of the choke. Pull the lever out to close the choke for starting when the engine is cold. Push the lever in to open the choke as the engine warms. Always push the lever fully in when operating the machine.

c. **Throttle:**

This lever controls the engine RPM. Turn the lever clockwise to increase engine speed and counter-clockwise to decrease.

d. **Fuel Shut-Off Valve:**

This lever controls the fuel valve for the flow of fuel to the engine. Flip the lever to the horizontal position to turn the fuel off and vertical to turn the fuel on.

e. **Starting Rope:**

This retracting rope and T bar is used to turn the engine over for starting. Grasp the T bar firmly and pull the rope sharply to start the engine. Close the choke if the engine is cold. Refer to the engine owners manual for complete starting details.

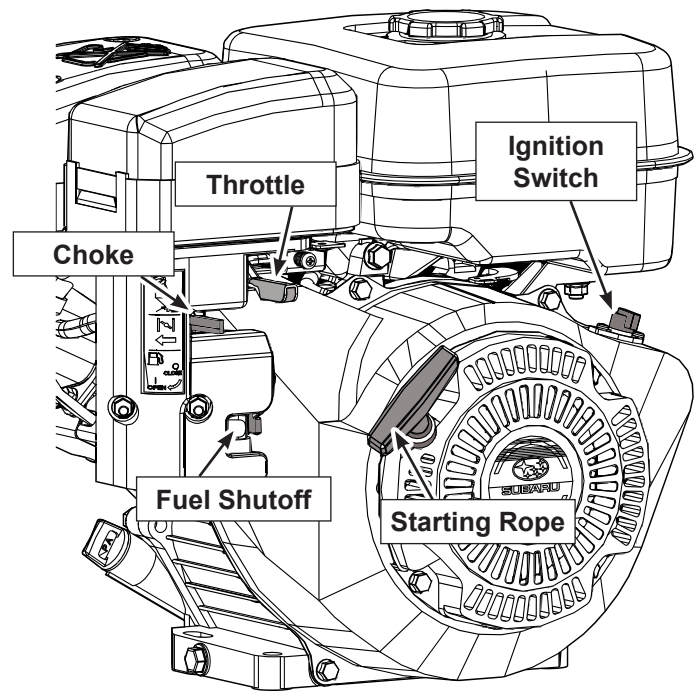
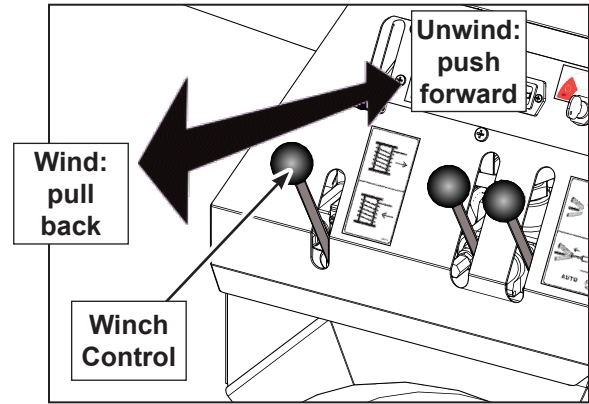
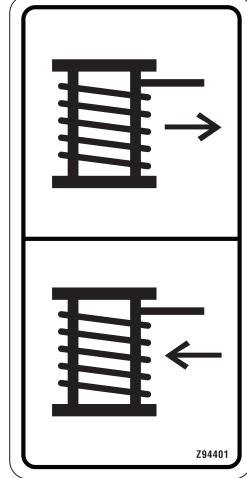

Fig. 4 CONTROLS: WP630:
SUBARU EX27 9HP

4.5.3. HYDRAULIC WINCH CONTROL

This 3-position "spring-loaded-to-center neutral" valve controls the flow of oil to the hydraulic motor powering the rope winch.

1. Pull the lever back and hold to start the winch and wind the rope.
2. Release the lever and it will return to neutral to stop winding the rope.
3. Push the lever forward to allow the rope to un-wind under power.



WP830 / WP860

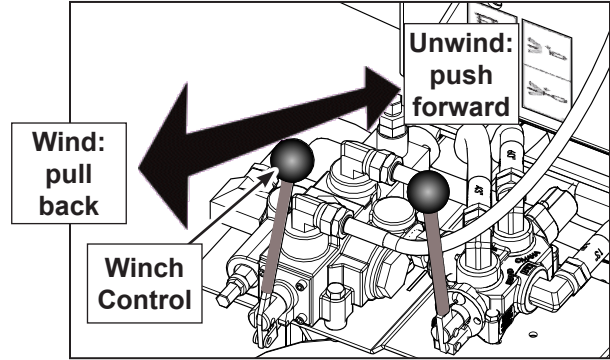

WP630

Fig. 5 WINCH CONTROL

4.5.4. WINCH GEAR LEVER:

This two-position lever controls the gears on the winch drive system.

1. Pull the lever back to engage the winch gear to the hydraulic motor.
2. Push it forward to disengage the winch gear from the hydraulic motor, allowing the gear free-wheel. The rope can then be easily pulled out to attach to a log.

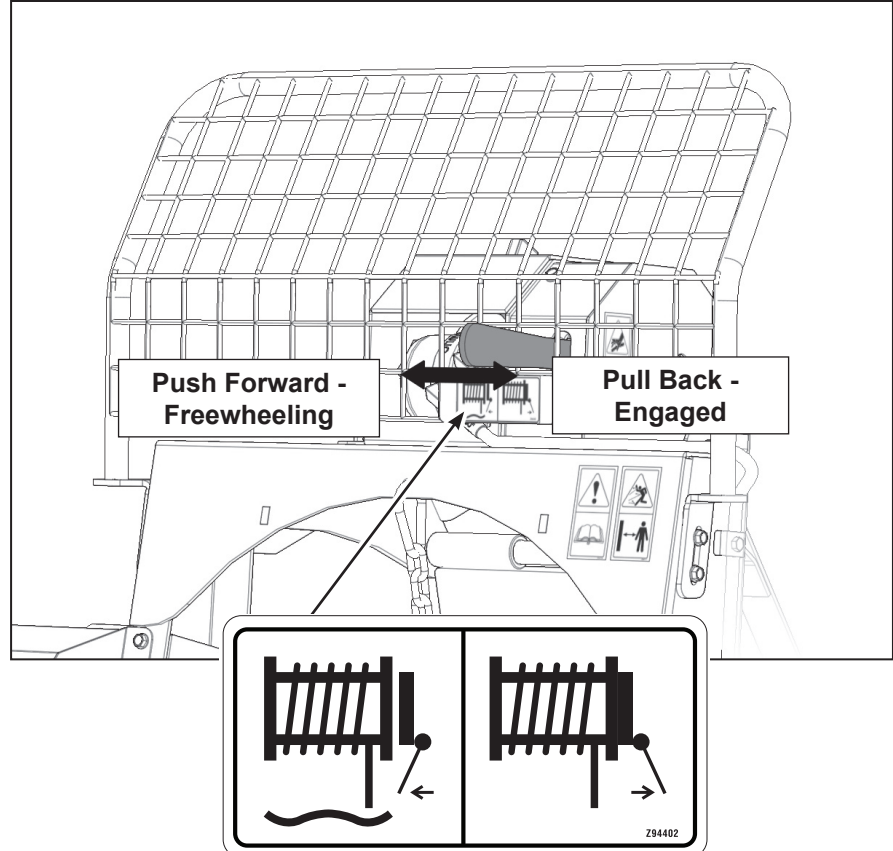

Fig. 6 WINCH GEAR LEVER & LABEL

4.5.5. HYDRAULIC CONTROLS & AUTO CYCLE

WP830 and WP860:

These two hydraulic levers control the extending and retracting movement of the Wood Processors' splitting cylinder rod. These 3-position "spring-loaded-to-center neutral" levers, control the flow of oil to the cylinder. They are equipped with a detent in the engaged position to allow the cylinder to move through its complete cycle and then return to its starting position automatically.

Lever #1 controls the first half of the cylinders auto cycle.

1. Pull it back into detent and the cylinder will start to extend automatically.
2. When the cylinder has fully extended, the lever will kick out to neutral and automatically stop the cylinder.

Lever #2 controls the second half of the cylinders auto cycle.

1. Pull it back into detent and the cylinder will start to retract automatically
2. When the cylinder has fully retracted, the lever will kick out to neutral and automatically stop the cylinder.

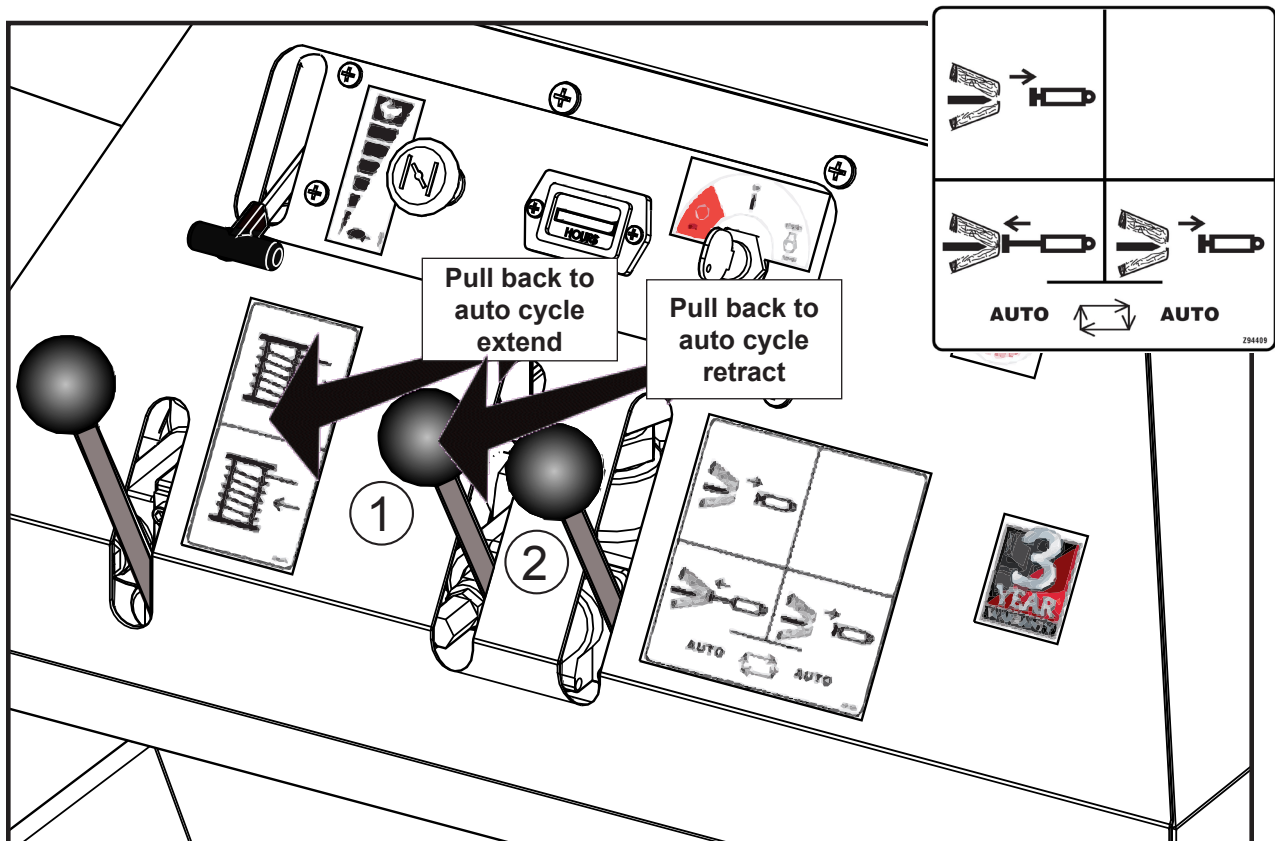

Fig. 7 WP830 and WP860 SPLITTER
CYLINDER CONTROL & LABEL

Pull both levers back into the detent position to initiate the splitting cycle. The cylinder will fully extend to split the log. When it reaches full extension (the log is split), #1 lever will pop out of detent. The cylinder will then begin to retract. When fully retracted #2 lever will come out of detent and the cylinder will stop.

Please note that lever #1 can be used to manually retract the cylinder:

1. Move lever #1 forward, the ram will begin to retract
2. Release the lever and it will return to neutral and the cylinder will stop.

WP630:

This 3-position "spring-loaded-to-center neutral" lever controls the flow of oil to the cylinder.

1. Pull the lever back and hold for the cylinder piston to extend and split the wood.
2. Once the wood is split, move the lever forward and place it in the detent position to retract the cylinder
3. Release the lever and the cylinder will continue automatically until it is fully retracted, the lever will then kick out to neutral and the cylinder piston will stop moving.

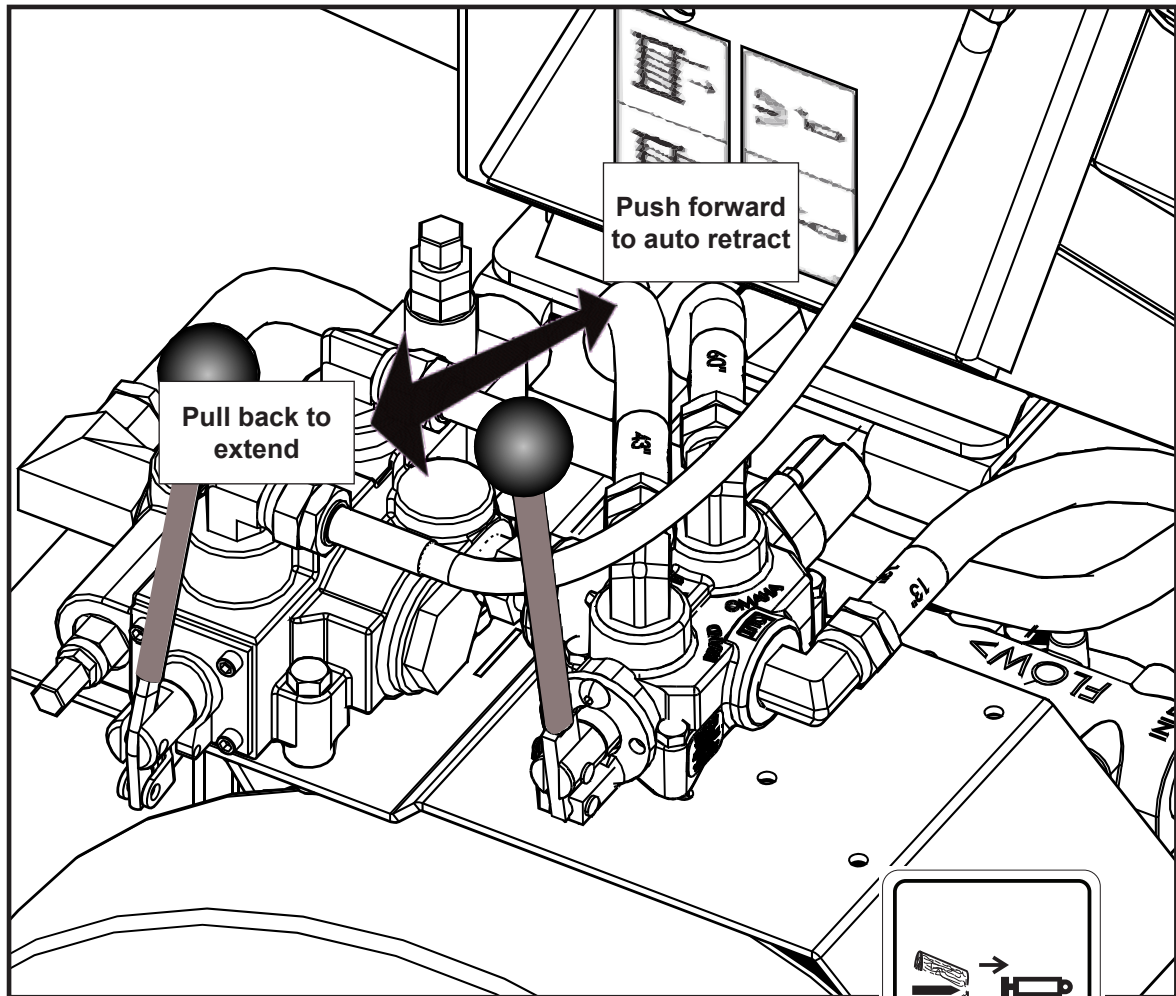
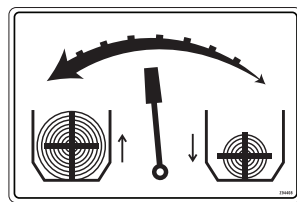

Fig. 8 WP630 SPLITTER CYLINDER CONTROL & LABEL

4.5.6. SPLITTING WEDGE HEIGHT LEVER:

This multi-position lever controls and sets the height position of the horizontal splitting wedge. At its lowest position the 4 way wedge becomes a two way wedge, to handle smaller logs, increasing the height allows for 4 way splitting of larger logs. Adjust the height as required.

1. Pull the lever out slightly to clear the adjustment cogs, then move the lever towards the engine to lower the splitter wedge.
2. To raise the wedge, pull the lever out slightly to clear the adjustment cogs, then move the lever away from the engine.
3. For even sized splits, align the centre wedge with the centre of the log.



Lever Label

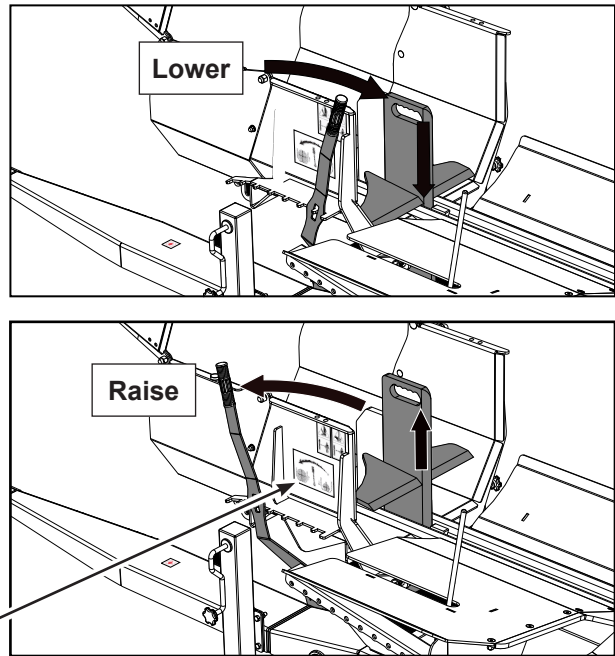

Fig. 9 SPLITTING WEDGE HEIGHT LEVER

4.5.7. ADJUSTABLE LOG LENGTH GUIDE:

This adjustable, spring loaded guide is used by the operator to quickly indicate when the log is at the desired length for cutting.

To position the guide to length:

1. Remove the snapper pin from the guide base
2. With a tape measure, measure from the saw guide to the rod on the log length guide.
3. Move the guide to the desired length and replace the snapper pin.
4. As you advance the log up the chute, the end of the log will contact the spring loaded guide rod, moving it and indicating that the log is at the correct length for cutting.

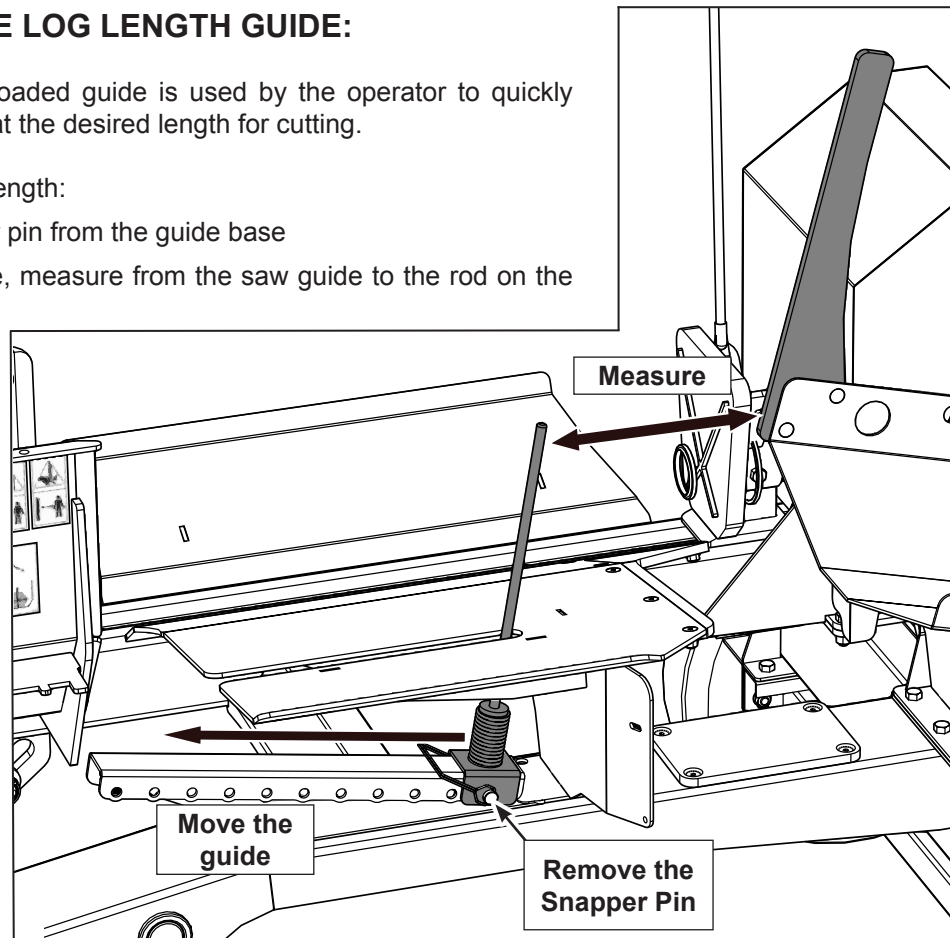

Fig. 10 LOG LENGTH

4.5.8. SPLITTER CHUTE HEIGHT ADJUSTER:

The adjustable sliding bracket controls the height of the end of the splitter chute, up to 54" (1.37 m). This allows for split wood to be loaded directly onto a conveyor, or into a high sided dumper with out any extra handling.

To adjust the splitter chute height:

1. Lift the splitter chute slightly to take pressure off of the adjuster.
2. Remove the latch pin that secures hitch pin.
3. Pull out the hitch pin that holds the adjuster in place.
4. Raise the splitter chute to the required height, line up the hitch pin holes and replace the hitch pin.
5. Secure the hitch pin with the latch pin.

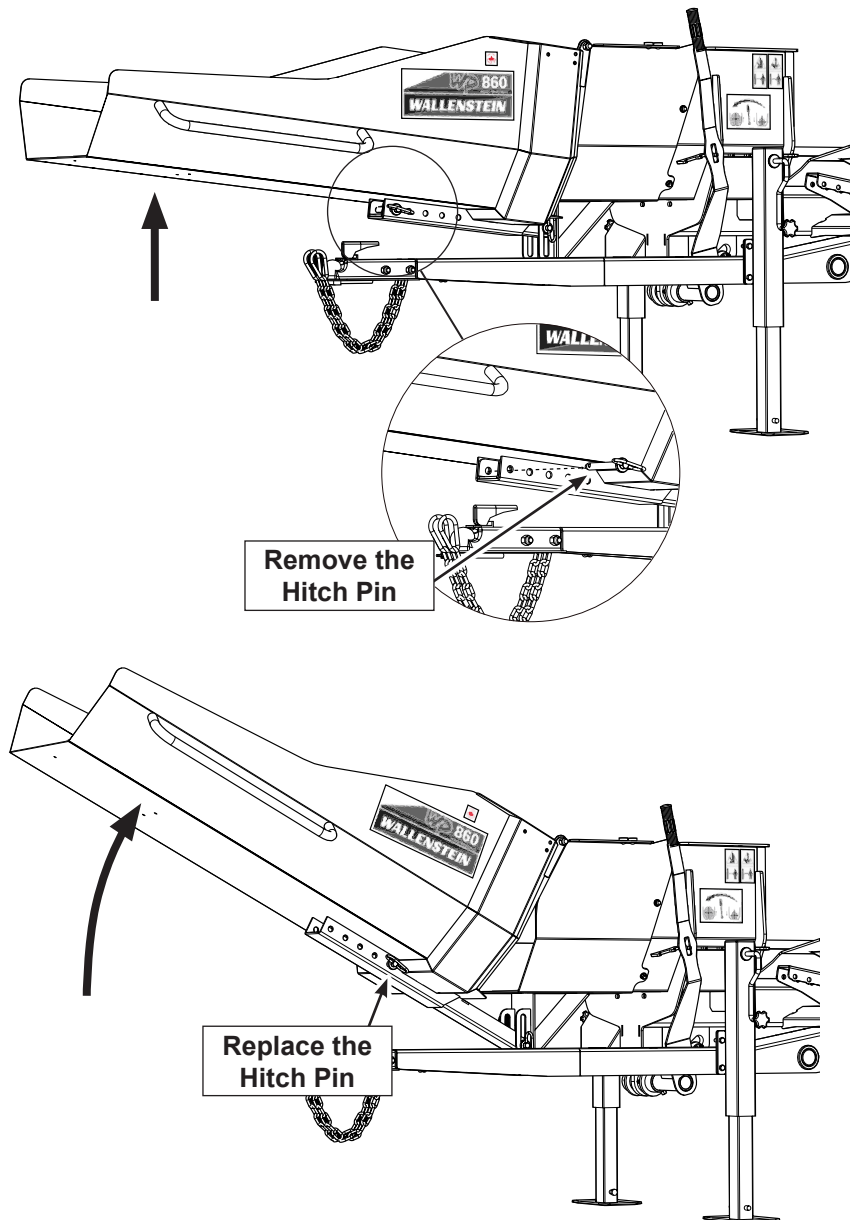
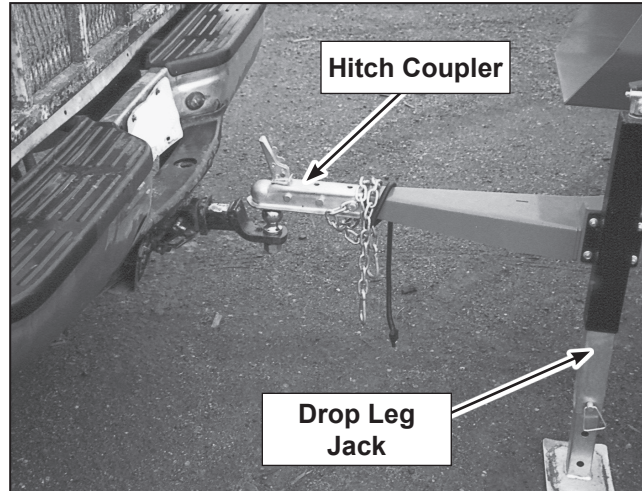

Fig. 11 SPLITTER CHUTE POSITION

4.6 ATTACHING AND UNHOOKING

When attaching the Wood Processor to a tow unit, the Wood Processor should always be located on a level, dry area that is free of debris and other foreign objects. When attaching the Wood Processor to a tow unit, follow this procedure:

1. Clear the area of bystanders, especially small children.
2. Make sure there is enough room and clearance to safely back up to the Wood Processor.
3. Using the drop leg jack, raise the trailer so that it is higher than the ball hitch on the tow vehicle.
4. Slowly back the tow vehicle until the hitch coupler and the ball are aligned.
5. Open the coupler latch.



6. With the drop leg jack, lower the trailer so the hitch coupler hitches over the ball.
7. Flip the coupler latch to lock the coupler around the ball.
8. Install the snapper pin through the coupler latch.

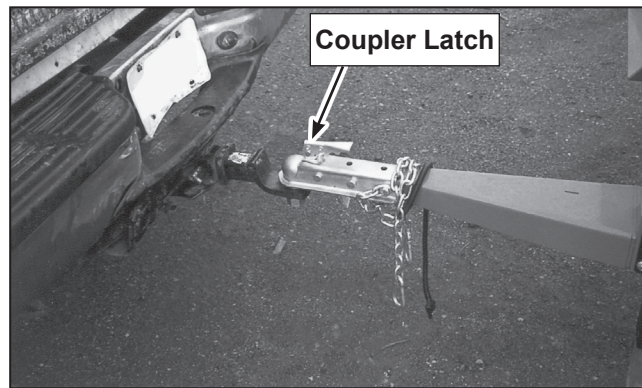

9. Attach the safety chain securely to the tow vehicle to prevent unexpected separation. Cross the chains under the hitch when attaching.
10. Connect the wiring harness of the trailer (if equipped) to the tow vehicle for the highway lights.
11. Raise and stow the drop leg jack.
12. Reverse the above procedure when unhooking.

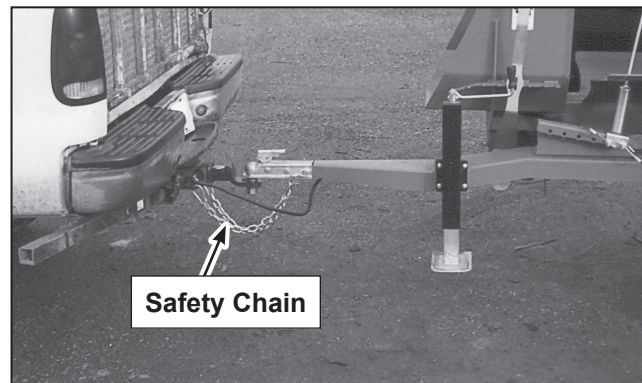

Fig. 12 SAFELY ATTACHED

4.7 MACHINE SET-UP

Follow this procedure to prepare and set-up the machine at the work site:

1. Use the tow unit to position the Wood Processor at the work site.

IMPORTANT

Position the machine so the prevailing wind/breeze blows the exhaust gases/fumes away from the operator's station.

2. Crank the drop leg jacks to raise the hitch coupler and unhook the tow vehicle from the Wood Processor
3. Adjust the drop leg jacks so the Wood Processor is level.
4. Remove the nuts from the log loader chute anchor bolts, one on each side of the chute.

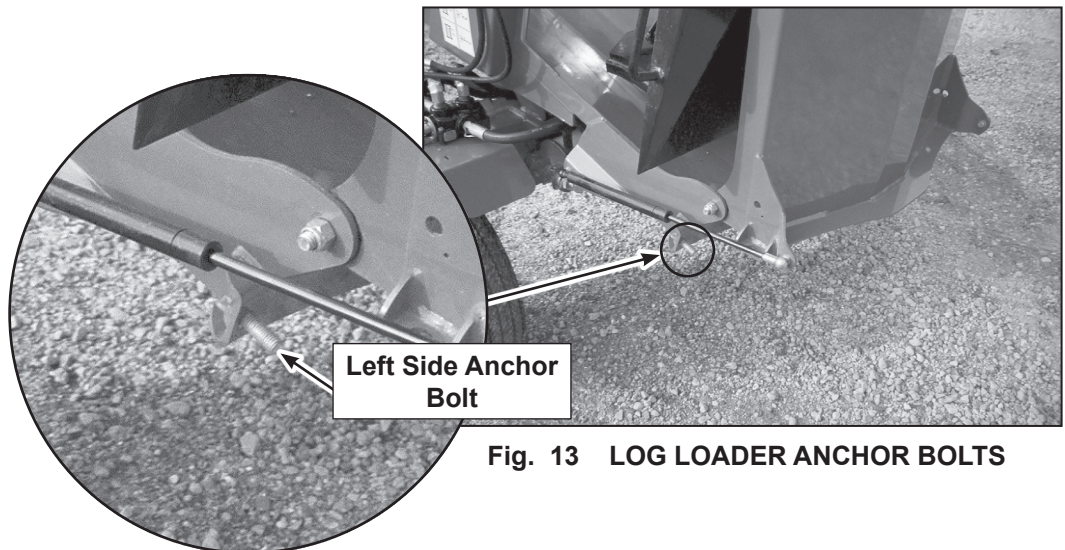
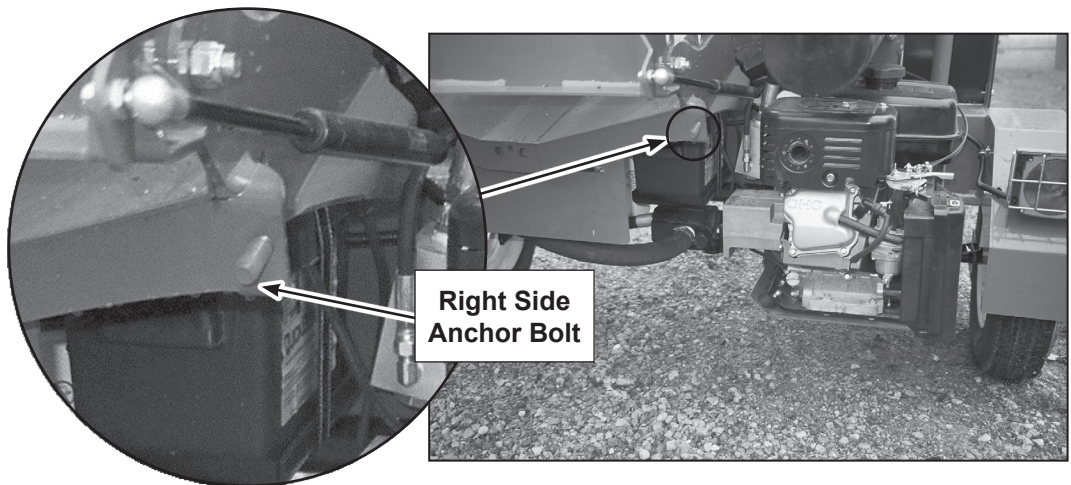
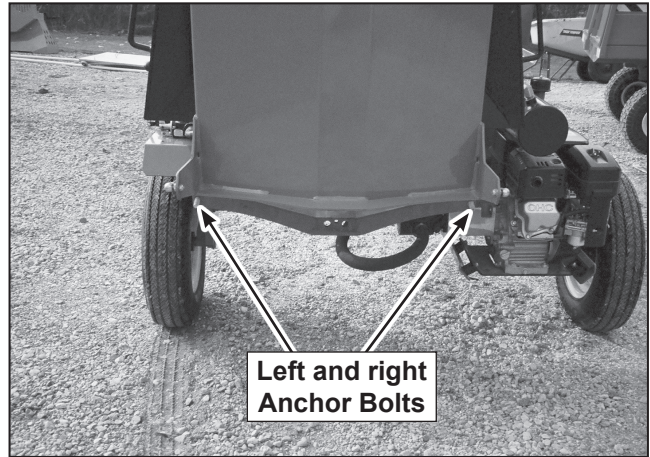

Fig. 13 LOG LOADER ANCHOR BOLTS

5. Remove the snapper pins securing the bracing jacks and turn them to the bracing position.
6. Replace the snapper pins to secure the jacks.

NOTE

Angle the jacks upward so they will contact the ground evenly when the chute is lowered.

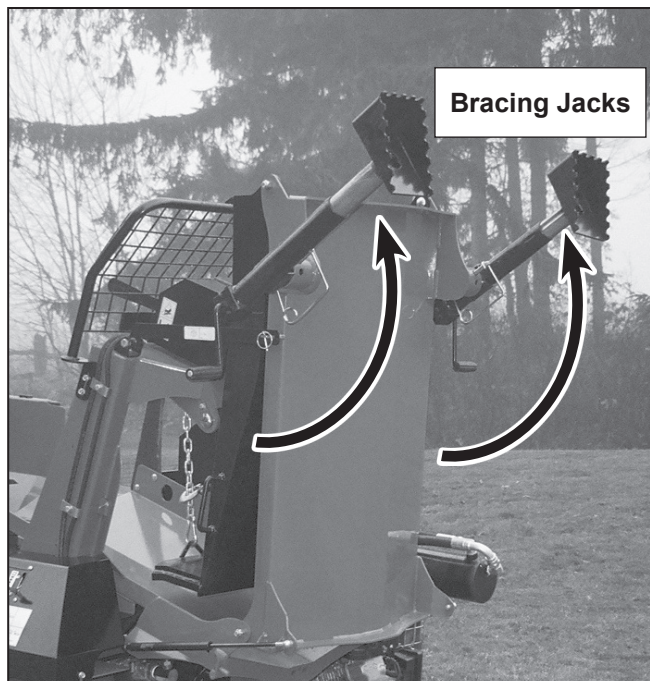

Fig. 14 BRACING JACKS

7. Remove the latch pin that holds the chute lock arm to the log loader chute.
8. Pull the lock arm away from the chute and swing it down. Secure it to the side of the frame with the latch pin.

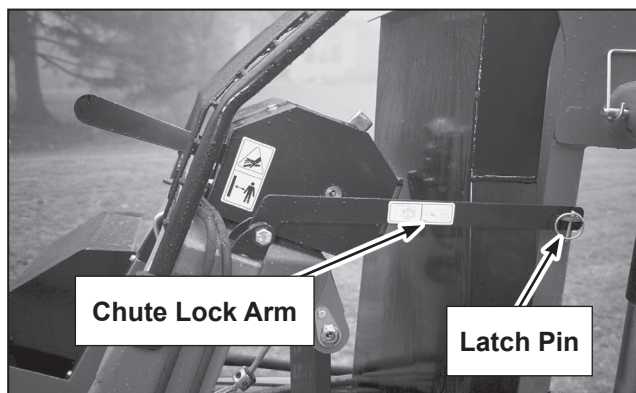

Fig. 15 LOCK ARM

9. Fold the log loader chute down.
10. Install and tighten the nuts for the log loader chute anchor bolts, on the left and right side.
11. Crank the bracing jacks till the jack feet are firmly on the ground.
12. Unfold the lead in chute
13. Unclip the winch hook from the log stabilizer chain.
14. Check that the log stabilizer chain allows the stabilizer to move freely and not hinder the log.

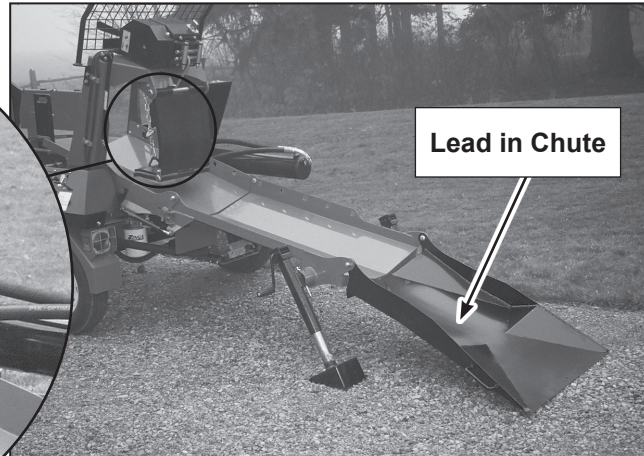
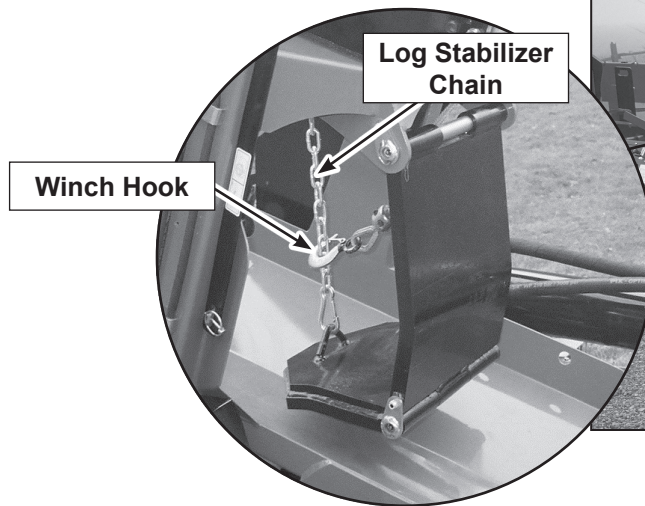
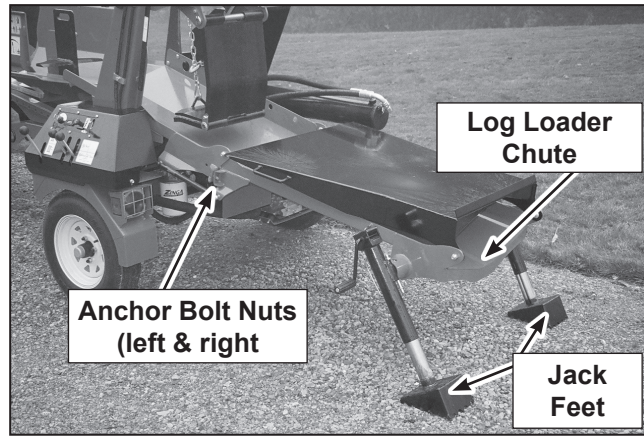
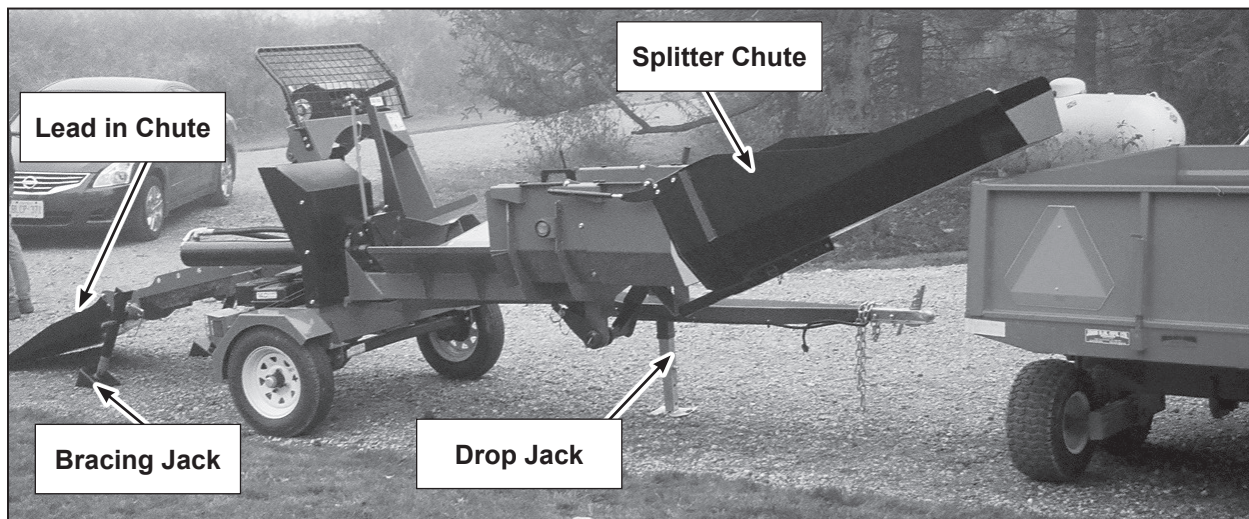

Fig. 16 LOG CHUTE



15. Finally, adjust the splitter chute to the required height, crank the bracing jacks so they are firmly on the ground, but ensure the front lip of the lead in chute is on the ground (to avoid catching on logs). If required, adjust the drop leg jacks so the lead in chute is level with the ground and the bracing jacks have a firm grip.
16. Move the wagon, trailer or conveyor into position under the discharge chute if desired or appropriate for your application.
17. Reverse the above procedure when preparing to leave the work site or transporting.

4.8 FIELD OPERATION



OPERATING SAFETY

- Read and understand operator's manual before starting. Review safety instructions annually.
- Close and secure all guards, deflectors and shields before starting and operating. If guard is removed, replace it.
- Do not allow anyone within 20 ft (6 m) of machine or logs during operation. Wood chips can be ejected and injure others. Keep children away.
- Move controls to neutral or off position, stop engine, remove ignition key and wait for all moving parts to stop before servicing, repairing or maintaining.
- Do not try to process more than one log at a time. The extra log can be ejected and cause injury.
- Keep your fingers and hands away from cracks in the log that can open while splitting.
- Always load logs by holding onto the sides of the log, not the top and bottom.
- Do not load the processor while the wedge is in motion.
- Do not try to split logs across the grain. Some logs can burst or splinter and fly out of the machine causing injury.
- For unevenly cut logs, always place the wide end down and the most square end against the splitting wedge.
- Never stand directly in line with rope while pulling.
- Do not touch rope during operation.
- Check rope condition before using winch. Rope may break during operation if it is cut, knotted, has broken strands or worn. Replace rope if damaged.
- Never use alcoholic beverages or drugs which can hinder alertness or coordination while operating this equipment. Consult your doctor about operating this machine while taking prescription medications.
- Operate only on level ground.
- Do not exceed winching angle of more than $\pm 25^\circ$ horizontally, to avoid tipping.
- Always winch up a slope. Do not winch across a slope.
- Do not operate on hillsides or when working area is cluttered, wet, muddy or icy to prevent slipping and tripping.
- Use care when pulling logs from a pile for splitting as they can roll when attaching rope or winching toward Wood Processor.
- Position machine so prevailing winds blow engine exhaust fumes away from operator's station.
- Keep working area clean and free of debris to prevent tripping. Operate only on level ground.
- Stop engine when leaving unattended.
- Do not exceed a safe travel speed when transporting.
- Read the chain saw operator's manual and follow all safety instructions.

Although the Wood Processor is easy to use, each operator should review this section to familiarize himself with the detailed safety and operating procedures. When using this machine, follow this procedure:

4.8.1. PREPARE

- Clear the area of bystanders, especially small children.
- Each operator must be trained and familiar with the set up and operation of the Wood Processor and its components.
- Review the machine components (see Section 4.2)
- Review and follow the Pre-Operation Checklist (see Section 4.4).
- Review operation and function of the controls (see section 4.5)
- Survey the work site, move to a clear, level work area and position at the work site. Do not start the Wood Processor until it is in position.
- Set up the machine (see section 4.7).
- Each person must wear appropriate **Personal Protective Equipment (PPE)** whenever operating the Wood Processor or working in the vicinity. This equipment is designed to prevent injury to any personnel in the area. This list includes but is not limited to:
 - Safety shoes with slip resistant soles.
 - Safety goggles or face shield.
 - Hearing protection.
 - Heavy or leather gloves

4.8.2. STARTING PROCEDURE:

- a. The Wood Processor should be set up and ready to run.
- b. Ensure the hydraulic controls are in neutral position (out of detent)
- c. Close the choke if the engine is cold.
- d. Move the throttle to its 1/4 throttle position.
- e. Open the fuel supply valve.
- f. **Electric Start (WP830 / 860):** Use the ignition key and turn it to the "start" indicator, to turn over the engine. Release the key when the engine has started and the key will return to the "run" position.
Manual Start (WP 630): Turn the ignition switch to "on". Grasp the T bar on the pull cord firmly, and pull the rope sharply to start the engine.
- g. Run the engine for a few minutes to allow it to warm.
- h. Gradually open the choke.
- i. Increase throttle setting to maximum speed for operation.
- j. The Wood Processor is ready to go!

4.8.3. STOPPING PROCEDURE:

- a. Stop winching, cutting or splitting logs.
- b. Move the throttle to idle position to slow the engine RPM.
- c. Set all hydraulic controls to neutral
- d. Turn off the ignition switch, to stop the engine. Shut off the fuel valve.

4.8.4. EMERGENCY STOPPING:

If an emergency occurs:

- a) **shut off the engine, and**
- b) **set all hydraulic controls to neutral**

Correct emergency situation before restarting engine and resuming work.

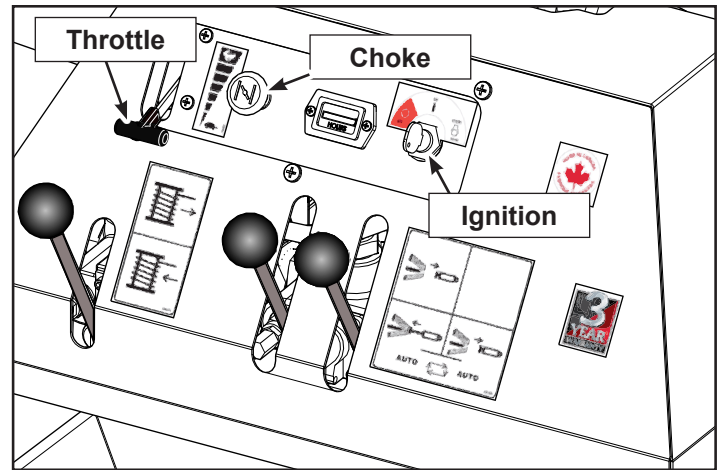

Fig. 17 ENGINE CONTROLS: WP830 & WP860

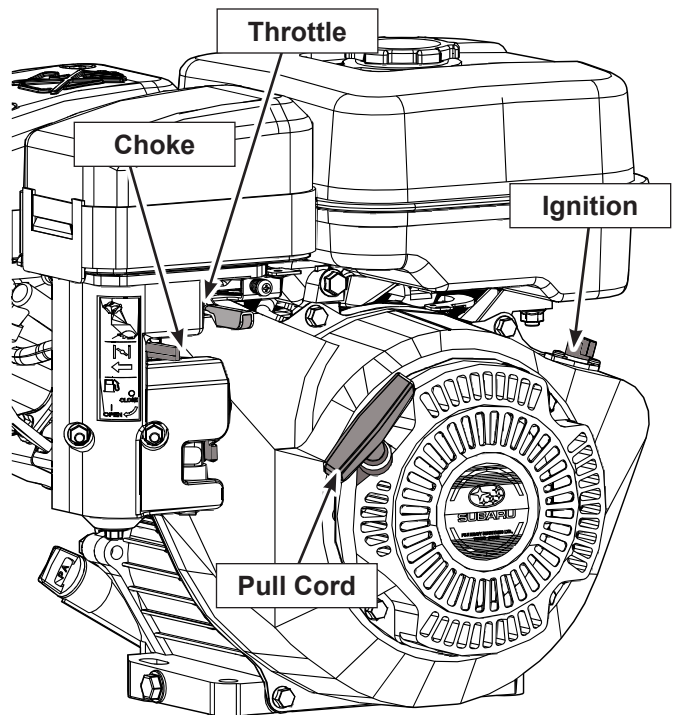

Fig. 18 ENGINE CONTROLS: WP630

4.8.5. PROCESSING OPERATION:

The Wood Processor is running and set up at the work site. Ensure the operator is wearing the appropriate safety equipment. (see Prepare). Have your chainsaw ready

A. Winching:

- a. Release the winch rope by moving the winch gear lever to the left.
- b. Grasp the hook on the winch rope, and pull the rope out to the logs.
- c. Wrap the winch strap around log. You may need to roll the log onto the scrap using a log peavey (available from your dealer).
- d. Attach the winch hook onto the winch strap.

Caution: Avoid using the rope to attach to the log, while winching the log the rope will sustain damage while dragging along the ground

- e. Engage winch drive mechanism with the winch gear lever.
- f. Use the winch to pull log into log lead in chute. Ensure the log does not catch on the front lip of the lead in chute.
- g. Continue to winch the log up log loader chute to the log stabilizer and stop the winch.
- h. Ensure the log is stable, disengage the winch gear, pull out the rope slightly.
- i. Detach the winch hook from the strap, and move the strap to the far end of the log.
- j. Pull out the winch rope and re-attach the winch hook.
- k. Engage the winch gear, and begin winching the log through the log stabilizer up to the log length guide.
- l. Cut the log to length, and allow it to roll into the splitting cradle.
- m. Check that the 4 way wedge is set to the appropriate height, adjust if necessary.
- n. Activate the hydraulic controls to split the log
- o. Winch the log up to the guide, and begin cutting again.



Winch Gear Lever



Winch Hook



Choker/Strap

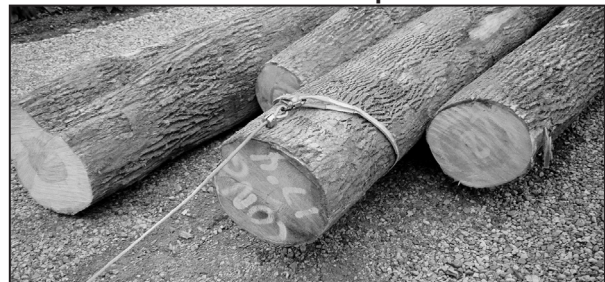

Winch Strap and Hook



Winching First Log



Re-attach

Fig. 19 PROCESSING

B. Second log:

As you finish the first log, you will find it is too short to winch in. At that point another log can be used to move the first one into the cutting area. When working with a second log, follow this procedure:

1. Ensure the log in the Wood Processor is stable, release the rope and hook.
2. Grasp the hook on the winch rope, and pull the rope out to the second log.
3. Wrap the winch strap around log. You may need to roll the log onto the scrap using a log peavey.
4. Attach the winch hook onto the winch strap.
5. Engage winch drive mechanism with the winch gear lever.
6. Use the winch to pull log into log lead in chute. Ensure the log does not catch on the front lip of the lead in chute.
7. Continue to winch the log up to the first log.
8. Use the second log to push the first one up to the cutting guide.
9. After a few cuts, reposition the winch strap to the far end of the second log, and continue winching and cutting.

C. Last log:

As you finish the last log, you will find it is too short to winch in. At that point, move the log using the log peavey as a lever inserted into holes at side of chute. Leaver the log up to the cutting guide, until it is fully processed.

 **CAUTION**

HEAVY LOG STABILIZER

UNDER NO CIRCUMSTANCES SHOULD ANYONE ATTEMPT TO PUSH A LOG BY HAND THROUGH THE STABILIZER OPENING. THE STABILIZER COULD DROP SUDDENLY AND CAUSE SERIOUS INJURY. ALWAYS USE APPROPRIATE TOOLS TO PUSH OR PULL THE LOG THROUGH THE OPENING.



Winching to Cutting Guide



Cut



End of First Log



Second Log



Push First Log



Last Log: Leaver the Peavey

Fig. 20 PROCESSING

4.8.6. PULL ANGLE:

It is recommended that the pull angle of the rope not exceed $\pm 25^\circ$ from the horizontal axis of the machine. Exceeding that angle can subject the machine to a tipping load and tip the machine over.

Use a log peavey to move the log in line with the Wood Processor to reduce or eliminate the tipping load.

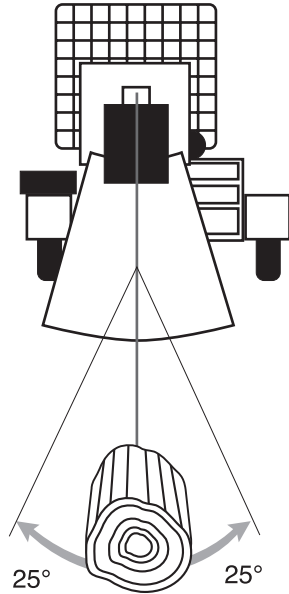

Fig. 21 PULL ANGLE

4.8.7. WOOD DISCHARGE:

The split pieces of log will be pushed out of the chute as each additional log moves through the machine. Set the chute at the appropriate position for making a pile on the ground or into a trailer, wagon or conveyor.

4.8.8. LOG CHAIN OR STRAP:

A 60" (1.5 m) winch strap is included with the Wood Processor. A standard log chain works well and is readily available from your dealer or distributor. To use the strap or chain, follow this procedure:

- Slide the log chain or strap under the log and connect on the other side. You may need to roll the log onto the strap / chain using a log peavey.
- Extend the rope to the log chain or strap.
- Connect the hook on the end of the rope to the end of the log chain or strap.
- Start engine, engage winch drive lock and pull the log into the machine.



Fig. 22 WAGON LOADING

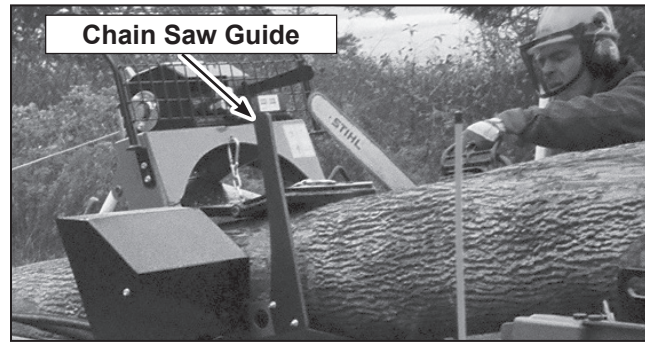

Fig. 23 STRAP

4.8.9. CUTTING:

Review the chain saw operator's manual and follow all safety instructions. Always wear appropriate Personal Protective Equipment (PPE) when using a chain saw.

- Ensure your chainsaw is sharpened and in good working order.
- Use the saw guide to safely align your cuts.
- Apply pressure and use the chain saw to cut the log.
- Be careful to decrease cutting pressure as you finish the cut, there is a chain saw bumper below the cutting area to minimize damage to the chain teeth if you accidentally follow through.
- Let the log roll into the splitting cradle



4.8.10. SPLITTING:

After each cut, the log will roll onto the splitting cradle. When splitting, follow this procedure:

- Using the wedge height lever, set the height of the 4 way wedge, according to the diameter of the log.
- Cut the log with the chain saw.
- Let the cut log roll into the splitting cradle split the wood:
- WP830 and WP860:** Pull both splitting control levers back into detent. The splitting ram will begin the auto-cycle: extend, split the wood, and retract automatically. The control levers reset to neutral when the auto-cycle completes. **WP630,** the operator must pull back and hold the hydraulic lever to extend and split the log, push the control forward to detent to automatically retract the ram and stop. The control lever will reset when the retract cycle completes.
- The most efficient cycle is:
 - Move log into position with winch or peavey.
 - Cut log and let it roll into the splitting cradle.
 - Engage splitter while the next log segment is moved into position.
 - Cut log. The log has finished splitting and is out of the splitting cradle.
 - Allow the cut log to roll into the cradle, split the cut log while winching the log into position for the next cutting.

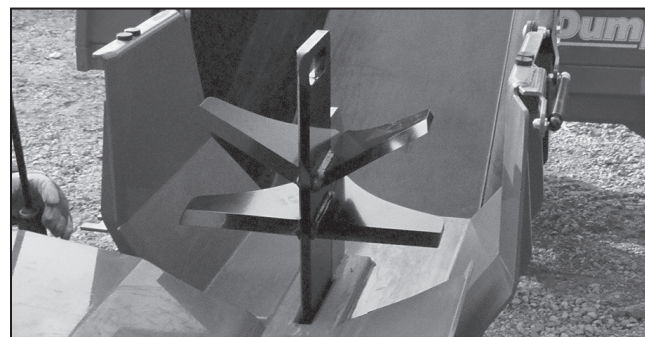
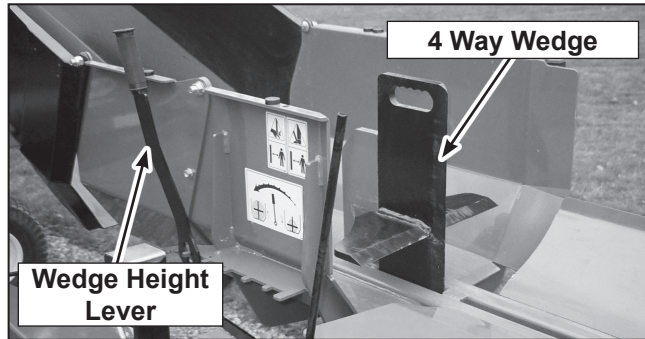
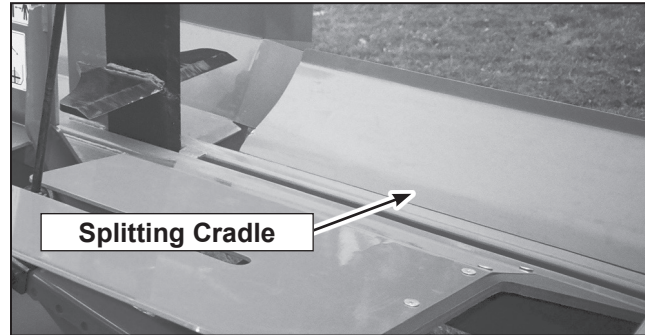

Fig. 24 SPLITTING

4.9 TRANSPORTING



TRANSPORT SAFETY

- Comply with state and local laws governing safety and transporting of machinery on public roads.
- Check that all the lights, reflectors and other lighting requirements are installed and in good working condition.
- Do not exceed a safe travel speed. Slow down for rough terrain and cornering.
- Be sure the Wood Processor is hitched positively to the tow unit with retainers installed through the drawbar pin or hitch jaw mechanism.
- Always install transport locks, pins or brackets before transporting.
- Plan your route to avoid heavy traffic.
- Do not drink and drive.
- Be a safe and courteous driver. Always yield to oncoming traffic in all situations, including narrow bridges, intersections, etc. Watch for traffic when operating near or crossing roadways.
- Never allow riders on the machine.

When transporting the machine, review and follow these instructions:

1. Clear the area of bystanders, especially small children.
2. Check that all the lights and reflectors required by the highway authorities are in place, clean and working.
3. Insure that the machine is securely attached to the tow unit with a retainer through the hitch latch.
4. Do not allow riders.
5. Never exceed a safe travel speed. Slow down when encountering rough road conditions and cornering.
6. Do not drink and drive.
7. Reconnect the lead in chute lock arm and latch pin, check that all components of the Wood Processor are secure for travel.

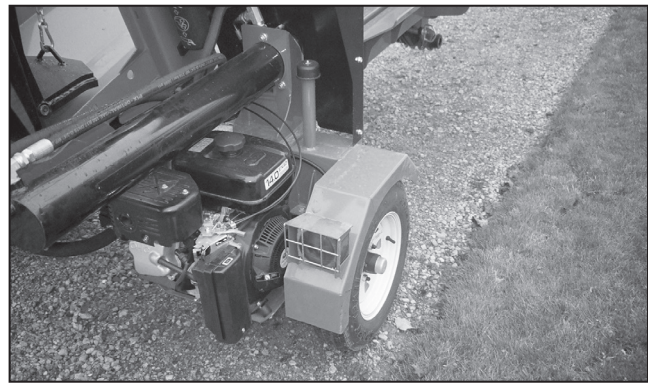

Highway Lights

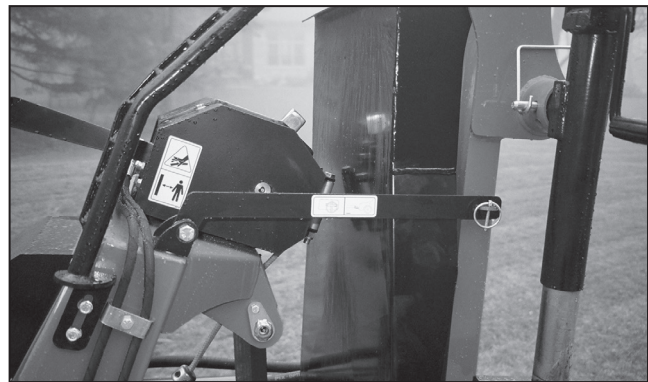

Lead In Chute Lock Arm

Fig. 25 TRANSPORTING

4.10 STORAGE



STORAGE SAFETY

- Store the unit in an area away from human activity.
- Do not permit children to play on or around the stored machine.
- Store the unit in a dry, level area. Support the frame with planks if required.
- Drain the fuel if storing for longer than 1 month

4.10.1 PLACING IN STORAGE

After the season's use or when the machine will not be used for a period of time, completely inspect all major systems of the Wood Processor. Replace or repair any worn or damaged components to prevent any unnecessary down time at the beginning of the next season.

1. Follow this procedure before storing:
2. Remove all material from the machine.
3. If storing for more than 1 month, discharge fuel to prevent gum in the fuel system and carburettor parts.
4. Thoroughly wash the machine with a pressure washer or water hose to remove all dirt, mud or debris.
5. Inspect all moving parts for entangled material. Remove all entangled material.
6. Check the condition of winch rope. Replace or adjust as required.
7. It is best to store the machine inside. If that is not possible, cover with a waterproof tarpaulin and tie down securely.

4.10.2 REMOVING FROM STORAGE

When removing this machine from storage, follow this procedure:

1. Remove the tarpaulin if covered.
2. Review and follow the pre-operation checklist.



Fig. 26 STORED (Typical)

5 SERVICE AND MAINTENANCE



MAINTENANCE SAFETY

- Good maintenance is your responsibility. Poor maintenance is an invitation to trouble.
- Follow good shop practices.
 - Keep service area clean and dry.
 - Be sure electrical outlets and tools are properly grounded.
 - Use adequate light for the job at hand.
- Make sure there is plenty of ventilation. Never operate the engine of the engine in a closed building. The exhaust fumes may cause asphyxiation.
- Before working on this machine, shut off the engine, set the brake, and turn fuel valve off.
- Never work under equipment unless it is blocked securely.
- Always use personal protection devices such as eye, hand and hearing protectors, when performing any service or maintenance work. Use heavy gloves when handling sharp components.
- Where replacement parts are necessary for periodic maintenance and servicing, genuine factory replacement parts must be used to restore your equipment to original specifications. The manufacturer will not be responsible for injuries or damages caused by use of unapproved parts and/or accessories.
- A fire extinguisher and first aid kit should be kept readily accessible while performing maintenance on this equipment.
- Periodically tighten all bolts, nuts and screws and check that all electrical and fuel connections are properly secured to ensure unit is in a safe condition.
- When completing a maintenance or service function, make sure all safety shields and devices are replaced before returning unit to service.

5.1 SERVICE

5.1.1 FLUIDS AND LUBRICANTS

1. Engine Oil:

Refer to the engine manufacturer's manual for maintenance and service information

2. Grease:

Use an SAE multi-purpose high temperature grease with extreme pressure (EP) performance. Also acceptable is an SAE multipurpose lithium base grease.

3. Engine Gasoline:

Use a standard automotive unleaded gasoline for all operating conditions.

Fuel tank capacity:

EX 27 Subaru 6.1 L (1.6 US Gal.)

EX 400 DP Subaru 7.0 L (2.2 US Gal.)

4. Hydraulic Oil:

Use Dexron III hydraulic oil for all operating conditions.

Reservoir 26 L (6.8 US Gal.)

5. Storing Lubricants:

Your machine can operate at top efficiency only if clean lubricants are used. Use clean containers to handle all lubricants. Store them in an area protected from dust, moisture and other contaminants.

5.1.2 GREASING

Use the Maintenance Checklist provided to keep a record of all scheduled maintenance.

1. Use a hand-held grease gun for all greasing.
2. Wipe grease fitting with a clean cloth before greasing, to avoid injecting dirt and grit.
3. Replace and repair broken fittings immediately.
4. If fittings will not take grease, remove and clean thoroughly. Also clean lubricant passageway. Replace fittings if necessary.

5.1.3 SERVICE ILLUSTRATION

See Service Record Chart

This illustration shows the general location of service points for all models in this manual.

Refer to your engine instruction manual for specific maintenance instructions / requirements

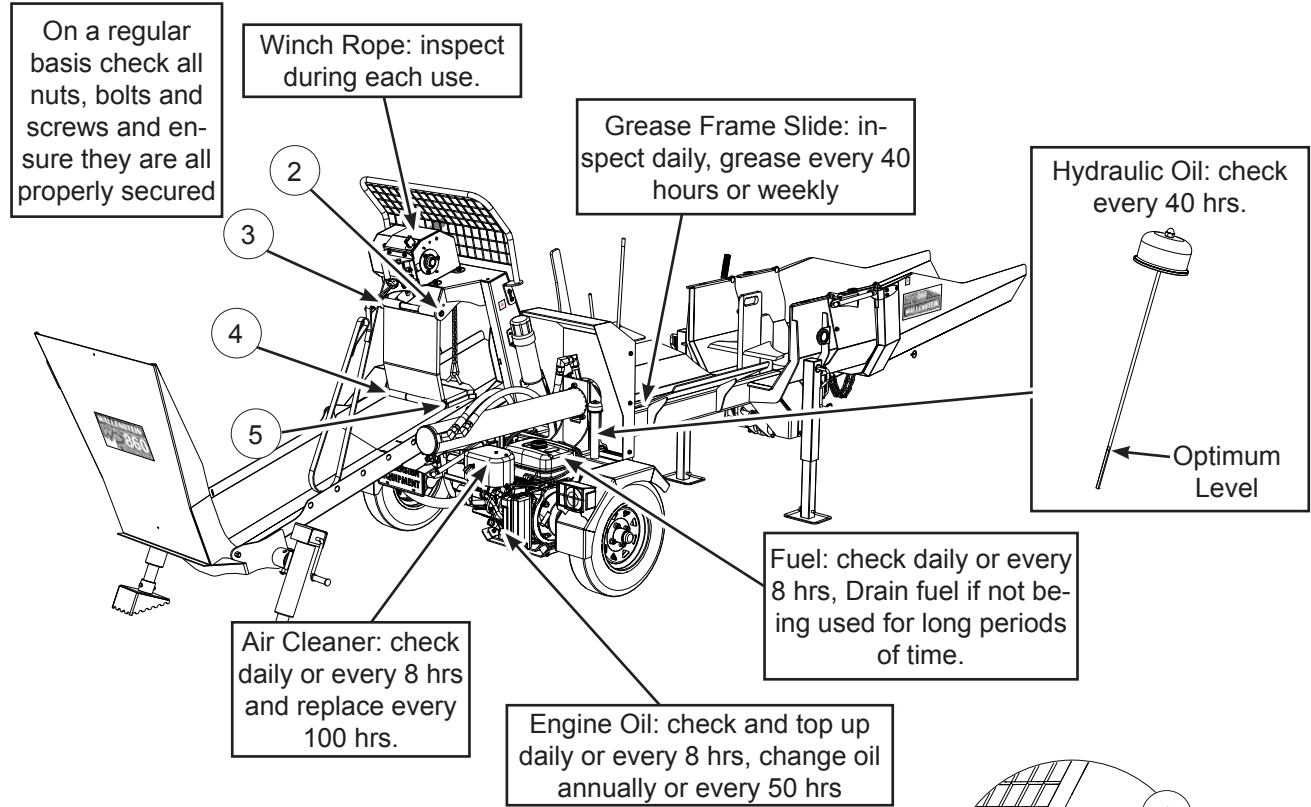

Location	Grease Points - 50 hrs or Annually
①	Winch
②	Upper Right Log Stabilizer
③	Upper Left Log Stabilizer
④	Lower Right Log Stabilizer
⑤	Lower Left Log Stabilizer
⑥	Wedge Adjustment Arm Bushing

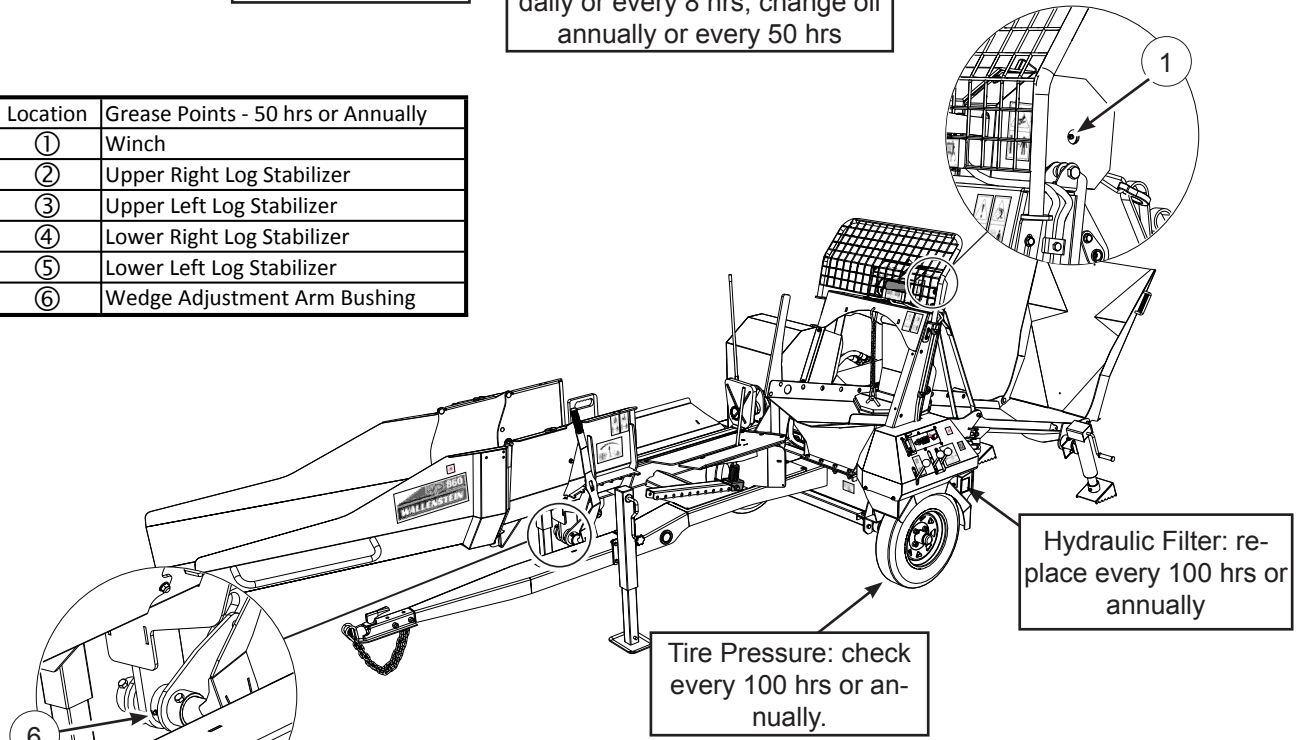

Every 100 hrs or annually. wash and clean the Wood Processor, remove entangled material, wood chips, small debris

On a regular basis check all jacks, hinge and swivel points, clean and lubricate as required

On a regular basis check the condition of all hydraulic lines, hoses and fittings. Replace any that are damaged. Re-route those that are rubbing, pinched or crimped. Tighten any fitting that is leaking. Ensure fittings are clean and free of dirt.

5.1.5 HYDRAULIC SYSTEM OIL FILTER & OIL CHANGE

1. Review the Operator's Manual for the Wood Processor.
2. Move controls to neutral or off position, stop engine, remove ignition key and wait for all moving parts to stop before servicing, repairing or maintaining.
3. Allow the machine to cool before changing the oil. Hot oil can cause burns if it contacts exposed skin. It is best to change oil while the machine is warm to keep the contaminants in suspension.
4. Be sure to chock the wheels to prevent the Wood Processor from moving while working under the machine.
5. Place a pan under the filter head.
6. Remove bottom hose and strainer (strainer on WP830 / 860 only) to drain oil.
7. Allow the oil to drain.
8. Remove hydraulic oil filter.
9. Apply a light coat of oil to the O ring and install the replacement filter. Snug up by hand and then tighten 1/2 turn.
10. Install and secure bottom hose and strainer.
11. Fill the reservoir with 26 L of Dexron III hydraulic oil.
12. Run the machine for 1-2 minutes while operating cylinder and check filter head for oil leaks.
13. If leaks are found around the filter, tighten slightly. Repeat step 9.
14. Check hydraulic reservoir oil level. Top up as required.
15. Dispose of the spilled oil in an approved container.

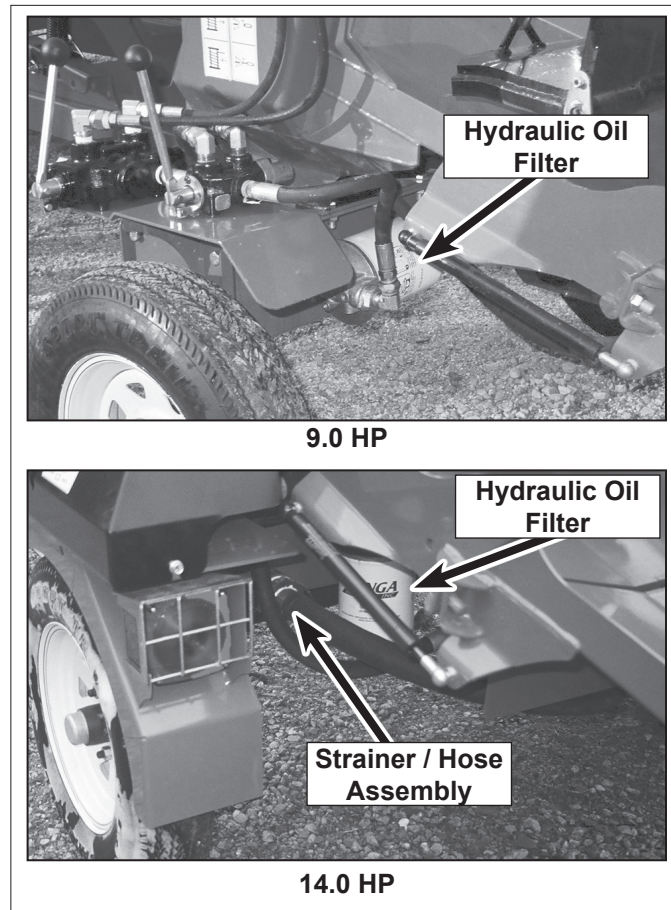

Fig. 27 HYDRAULIC SYSTEM FILTER

6 TROUBLE SHOOTING

The Wallenstein Trailer Woodsplitter uses hydraulic power to move a hydraulic cylinder rod to split wood or logs. It is a simple and reliable system that requires minimal maintenance.

In the following chart, we have listed many of the problems, causes and solutions to the problems that you may encounter.

If you encounter a problem that is difficult to solve, even after having read through this trouble shooting section, please call your local dealer, distributor or Wallenstein. Before you call, please have this Operator's Manual and the serial number from your Woodsplitter ready.

6.1 TROUBLE SHOOTING CHART



Always wear the appropriate safety gear when trouble shooting, performing maintenance or working around the machine. This includes but is not limited to:

- Hard hat for protection to the head.
- Heavy gloves for hand protection.
- Face mask for protection to the face and eyes.
- Safety shoes with slip resistant soles and steel toes

PROBLEM	CAUSE	SOLUTION	CAUTION	
Winch motor does not move	Rope jammed	Disengage winch gears, pull rope out and guide rope on to the spool when retracting		
Rope does not pull out	Winch gears engaged	Disengage winch gears		
Rope does not retract	Winch gears disengaged	Engage winch gears		
Cylinder rod moves slowly or doesn't move.	Wood jammed around wedge.	Shut machine off and safely remove wood.		Ensure machine is off
Cylinder rod / Winch motor moves slowly or doesn't move.	No pressurized hydraulic oil.	Oil filter plugged. Change filter.		Ensure machine is off and cooled down.
	No pressurized hydraulic oil	Low hydraulic oil level, top up		Ensure machine is off and cooled down
	Not enough pressure.	Call technician, system relief setting may be low.		Ensure machine is off and call hydraulic technician.
	Low engine speed.	Check that choke is off, check throttle is set to maximum.		
Control handle doesn't go to neutral after rod is fully retracted.	Detent set too tight.	Call technician, adjustment required with detent on valve.		Ensure machine is off and call hydraulic technician.
	Hydraulic fluid too cold.	Allow machine to warm up.		
	Hydraulic fluid is too old or contaminated.	Change hydraulic fluid and filter		Ensure machine is off and cooled down.
Control handle goes to neutral before rod is fully retracted.	Detent set too loose.	Call technician, adjustment required with detent on valve.		Ensure machine is off and call hydraulic technician.
Control handle doesn't go to neutral when released.	Control may be damaged.	Call technician, control may need service or be replaced.		Ensure machine is off and call hydraulic technician.
Cylinder stops on contact with wood.	Second stage on pump not functioning.	Call technician, pump may need service or be replaced.		Ensure machine is off and call hydraulic technician.
Wedge jumps.	Wedge frame jamming.	Lubricate wedge frame wear plates.		Ensure machine is off.
Leaking hydraulic hose.	Hose worn or damaged.	Replace hose.		Ensure machine is off and cooled down.
Leaking cylinder.	Seals worn.	Call technician, seal replacement may be required.		Ensure machine is off and call hydraulic technician.
Engine related issues.	<i>Refer to your engine instruction manual for specific trouble shooting instructions / requirements.</i>			

7 SPECIFICATIONS

7.1 MECHANICAL

Model	WP860	WP830	WP630
Engine Power / Model	14 HP (10.3 kW) / EX 400 DP Subaru Engine		9 HP (9.6 kW) / EX27 Subaru Engine
Hydraulic Pump Flow / Type	22 GPM (83.2 lpm) / 2 Stage		16 GPM (60.5 lpm) / 2 Stage
Cylinder Diameter/Stroke	4.5" / 36" 114 mm / 914 mm	4.5" / 24" 114 mm / 609 mm	4.5" / 24" 114 mm / 609 mm
Splitter Control Valve Type	Dual Valve Open Centre w/ Auto Cycle Detent		Open Centre w/ Auto Return Detent
Full Stroke Splitting Cycle Time	11 Second	7 Second	11 Second
Splitting Force	25 Ton		
Max. Split Length	34" (86 cm)	22" (56 cm)	
Max. Log Diameter	22" (56 cm)		
Wedge Configuration	Adjustable 4-Way		
Suspension	Torflex® Suspension		Solid Axle
Tire Size / Type	5.30 x 12.00 / Highway Tire		
Ball Hitch Size	2" (50mm) Ball Coupler & Safety Chains		
Trailer Light Package	Highway Lights & Wiring		n/a
Weight	1970 lbs. (894 kg)	1840 lbs.(835 kg)	1600 lbs (726 kg)
Dimensions Extended (LxWxH)	238" x 62" x 72" 6.0m x 1.6m x 1.8m	210" x 62" x 72" 5.3m x 1.6m x 1.8m	210" x 62" x 72" 5.3m x 1.6m x 1.8m
Dimensions Folded (LxWxH)	150" x 62" x 72" 3.8m x 1.6m x 1.8m	122" x 62" x 72" 3.1m x 1.6m x 1.8m	122" x 62" x 72" 3.1m x 1.6m x 1.8m
Winch	Hydraulic, Valve Operated Winch		
Winch Rope Length	50' (15.2 m)		
Winch Pulling Force	1550 lbs. (703 kg)		
Discharge Chute Height	54" (1.4 m) Max.		
Hydraulic Fluid Capacity	6.8 US Gal. (26 L)		
Winch Strap			
Accessories	Adjustable 6-way Wedge Option (#2089W571)		
	Nylon Chainsaw Holster (#2089A570)		
	48" (1.2 m) Log Peavey (#299001)		
	Firewood Net Frame (#2089A580)		
	Firewood Net (#Z99007)		

SPECIFICATIONS SUBJECT TO CHANGE WITHOUT NOTICE

7.2 BOLT TORQUE

CHECKING BOLT TORQUE

The tables shown give correct torque values for various bolts and capscrews. Tighten all bolts to the torques specified in chart unless otherwise noted. Check tightness of bolts periodically, using bolt torque chart as a guide. Replace hardware with the same strength bolt.

ENGLISH TORQUE SPECIFICATIONS						
Bolt Diameter "A"	Bolt Torque*					
	SAE 2 (N.m) (lb-ft)		SAE 5 (N.m) (lb-ft)		SAE 8 (N.m) (lb-ft)	
1/4"	8	6	12	9	17	12
5/16"	13	10	25	19	36	27
3/8"	27	20	45	33	63	45
7/16"	41	30	72	53	100	75
1/2"	61	45	110	80	155	115
9/16"	95	60	155	115	220	165
5/8"	128	95	215	160	305	220
3/4"	225	165	390	290	540	400
7/8"	230	170	570	420	880	650
1"	345	225	850	630	1320	970

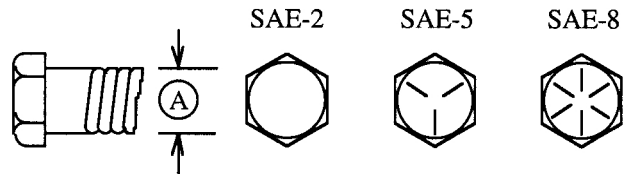

Torque figures indicated are valid for non-greased or non-oiled threads and heads unless otherwise specified. Therefore, do not grease or oil bolts or capscrews unless otherwise specified in this manual. When using locking elements, increase torque values by 5%.

* Torque value for bolts and capscrews are identified by their head markings.

METRIC TORQUE SPECIFICATIONS				
Bolt Diameter "A"	Bolt Torque*			
	8.8 (N.m) (lb-ft)		10.9 (N.m) (lb-ft)	
M3	0.5	0.4	1.8	1.3
M4	3	2.2	4.5	3.3
M5	6	4	9	7
M6	10	7	15	11
M8	25	18	35	26
M10	50	37	70	52
M12	90	66	125	92
M14	140	103	200	148
M16	225	166	310	229
M20	435	321	610	450
M24	750	553	1050	774
M30	1495	1103	2100	1550
M36	2600	1917	3675	2710

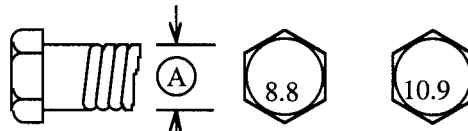

7.3 HYDRAULIC FITTING TORQUE

Tightening Flare Type Tube Fittings *

1. Check flare and flare seat for defects that might cause leakage.
 2. Align tube with fitting before tightening.
 3. Lubricate connection and hand tighten swivel nut until snug.
 4. To prevent twisting the tube(s), use two wrenches. Place one wrench on the connector body and with the second tighten the swivel nut to the torque shown.
- The torque values shown are based on lubricated connections as in reassembly.

HYDRAULIC FITTING TORQUE					
Tube Size OD	Nut Size Across Flats	Torque Value*		Recommended Turns To Tighten (After Finger Tightening)	
		(N.m)	(lb-ft)	(Flats)	(Turn)
(in.)	(in.)				
3/16	7/16	8	6	1	1/6
1/4	9/16	12	9	1	1/6
5/16	5/8	16	12	1	1/6
3/8	11/16	24	18	1	1/6
1/2	7/8	46	34	1	1/6
5/8	1	62	46	1	1/6
3/4	1-1/4	102	75	3/4	1/8
7/8	1-3/8	122	90	3/4	1/8

8 ACCESSORIES

Call your dealer for pricing and availability

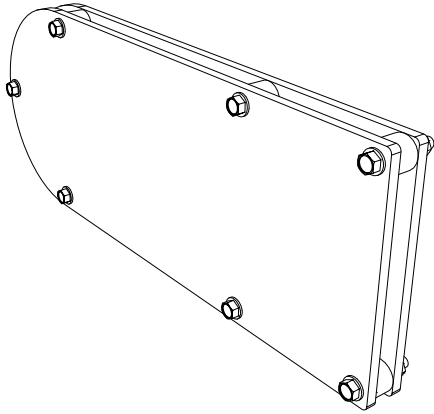
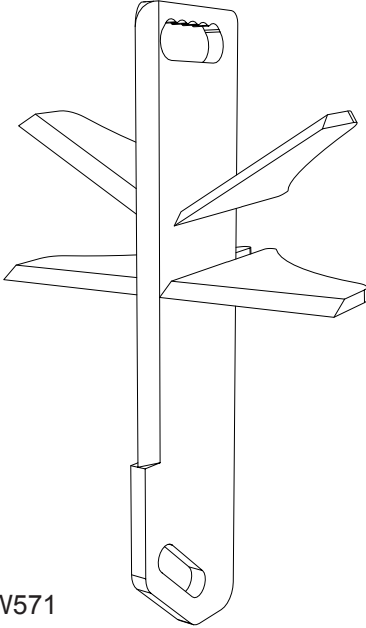
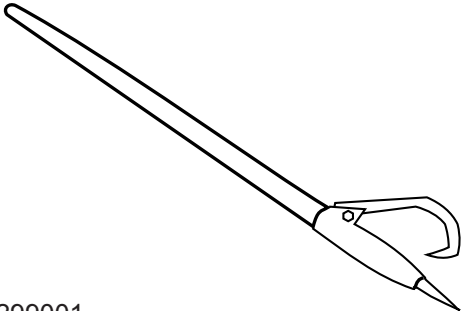
 <p>#2089A570</p>	<p>#2089A570 NYLON CHAINSAW HOLSTER</p> <p>For models: WP630, WP830, WP860 easy to install, fastens to Wood Processor</p> <p>Nylon holder, safely holds your chainsaw keeping it off the ground and out of the way!</p>
 <p>#2089W571</p>	<p>#2089W571 6-WAY WEDGE</p> <p>For models: WP630, WP830, WP860 easy to install in minutes, and you're ready to go!</p> <p>6 way splitting wedge, Boost your productivity and make quick work out of chunks by splitting into six pieces at once. This is an ideal way to save time</p>
 <p>#299001</p>	<p>#299001 48" LOG PEAVEY</p> <p>Helps to move those heavy log timbers into position, and finish getting your last logs through the Wood Processor!</p>

9 INDEX

A		P	
ACCESSORIES	48	PEAVEY	48
AUTO CYCLE	24	PPE	32
AUTO RETRACT	25	S	
B		SAFETY	7
BRACING JACKS.....	30	BATTERY	13
BREAK-IN	20	EQUIPMENT.....	9
C		GAS MOTOR	14
CHAIN SAW GUIDE.....	37	GENERAL.....	8
CHART	42	HYDRAULIC	11
CHOKE.....	21	MAINTENANCE.....	11
COMPONENTS.....	19	OPERATING	12
COUPLER.....	28	PREPARATION.....	10
E		REFUELLING	13
EMERGENCY	33	SAFETY SIGNS	9
EMERGENCY STOPPING.....	33	STORAGE.....	13
ENGINE.....	40	TIRE.....	13
ENGINE.....	42	TRAINING.....	10
ENGINE OIL.....	40	TRANSPORT	11
F		SAFETY SIGN.....	16
FILTER	43	SECOND LOG	35
FLUIDS.....	40	SERIAL NUMBER.....	5
FUEL SHUT-OFF	21	SERVICE AND MAINTENANCE	
G		SERVICE ILLUSTRATION.....	41
GASOLINE.....	40	SERVICE RECORD CHART	42
GREASE	40	SIGN-OFF FORM.....	15
H		SPECIFICATIONS.....	45
HITCH.....	28	STARTING	33
HOLSTER	48	STARTING ROPE	22
HOOK.....	31	STOPPING	33
HYDRAULIC	41	STORAGE.....	39
HYDRAULIC OIL	40	STRAP	36
I		T	
IGNITION.....	21	THROTTLE	21
ILLUSTRATION	41	TORQUE	46
L		TROUBLE	44
LAST LOG	35	TROUBLE SHOOTING.....	44
LOCK ARM	30	W	
LUBRICANTS	40	WARRANTY.....	3
O		WEDGE	26, 48
OPERATION	17	WINCH	23
		WINCHING	34