

# PARTS MANUAL

Serial number 1102975 and up

## WXT15V Log Splitter

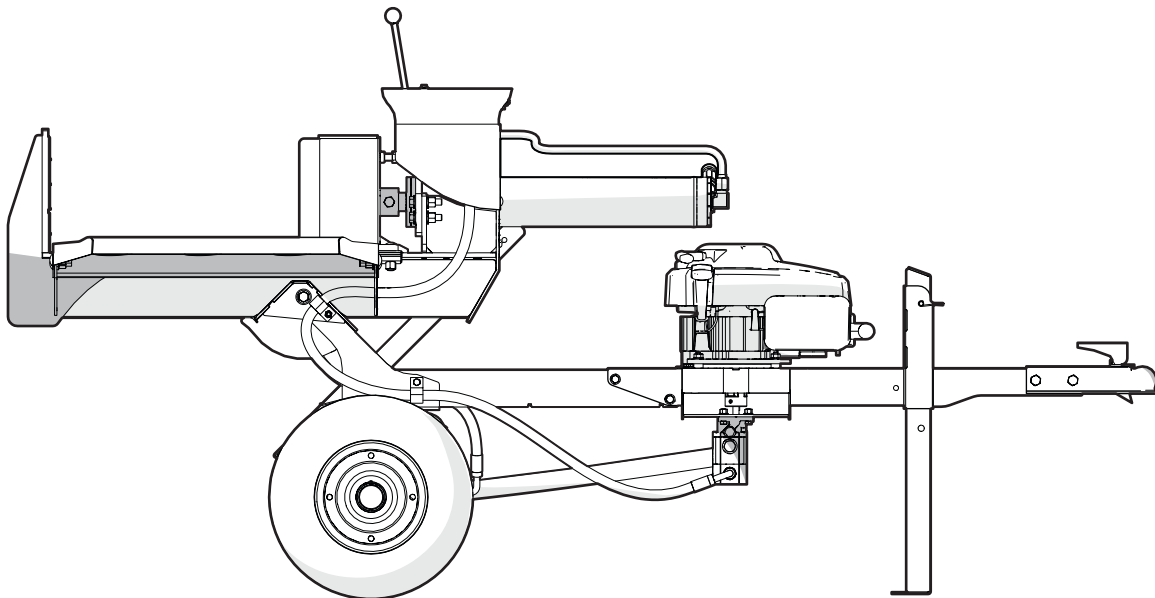

# Table of Contents

**Introduction .....3**  
**Model and Serial Number Location.....3**  
**Main Parts.....4**  
**Log Splitter Assembly.....5**  
**Main Frame Assembly.....6**  
**Main Base Assembly.....7**  
**Engine and Hydraulics Assembly .....8**  
**Z56209 Valve Components .....9**  
**Hydraulic Circuit.....10**  
**Label Locations .....11**  
**Accessories .....12**  
**Bolt Torque .....13**  
**Hydraulic Fitting Torque.....14**

## Introduction

### **! WARNING!**

For safety, operation, and maintenance information, see the Operator's Manual for your product.

Only qualified people are approved to maintain the machine.

### **! WARNING!**

Replace all safety labels that are missing, damaged, or illegible. If a component is replaced and it has a safety label on it, apply a safety label to the new component. If a person operates a machine with missing, damaged, or illegible safety labels it puts them at risk of serious injury or death.

S100W-01

This document provides information about the original equipment manufacturer (OEM) components (parts). Always replace a part with the correct OEM part. For service, support, or to order parts, contact your local Wallenstein Equipment dealer or distributor.

Always provide the model and serial number of your Wallenstein product when you order parts, or request service or other information. The model and serial number location is shown in the following illustration.

Record the model and serial number of your product here:

Model:

Serial Number:

The information contained in this document was current at the revision date noted on the bottom of each page. Wallenstein Equipment reserves the right to change product specifications at any time without notice. If your product specifications are different from the information in this document, contact your local dealer or distributor. To find a local dealer or distributor, go to [WallensteinEquipment.com](http://WallensteinEquipment.com) and select **Dealer Locator** at the bottom of the page.

**Wallenstein Equipment Inc. • © 2024. All rights reserved.**

No part of this work may be copied, reproduced, replaced, distributed, published, displayed, modified, or transferred in any form or by any means except with the prior permission of Wallenstein Equipment Inc.

## Model and Serial Number Location

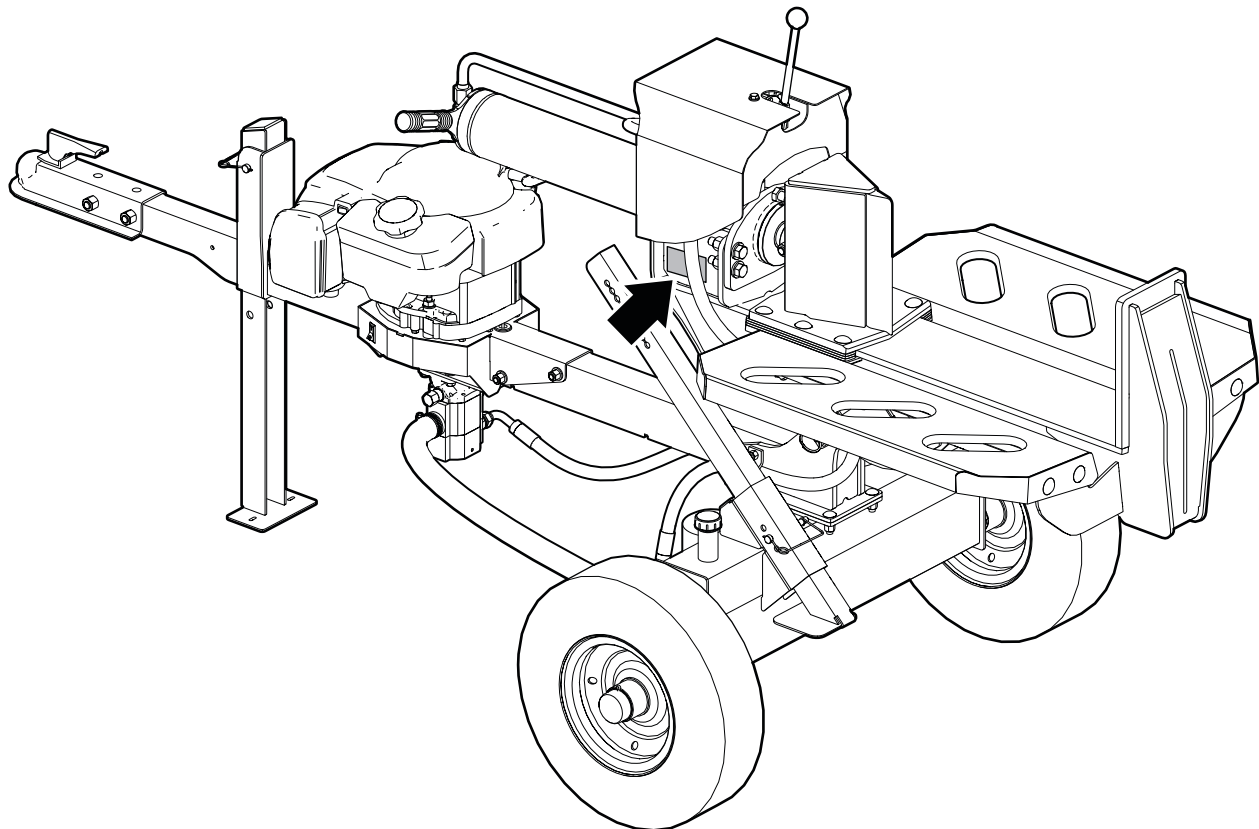

# Main Parts

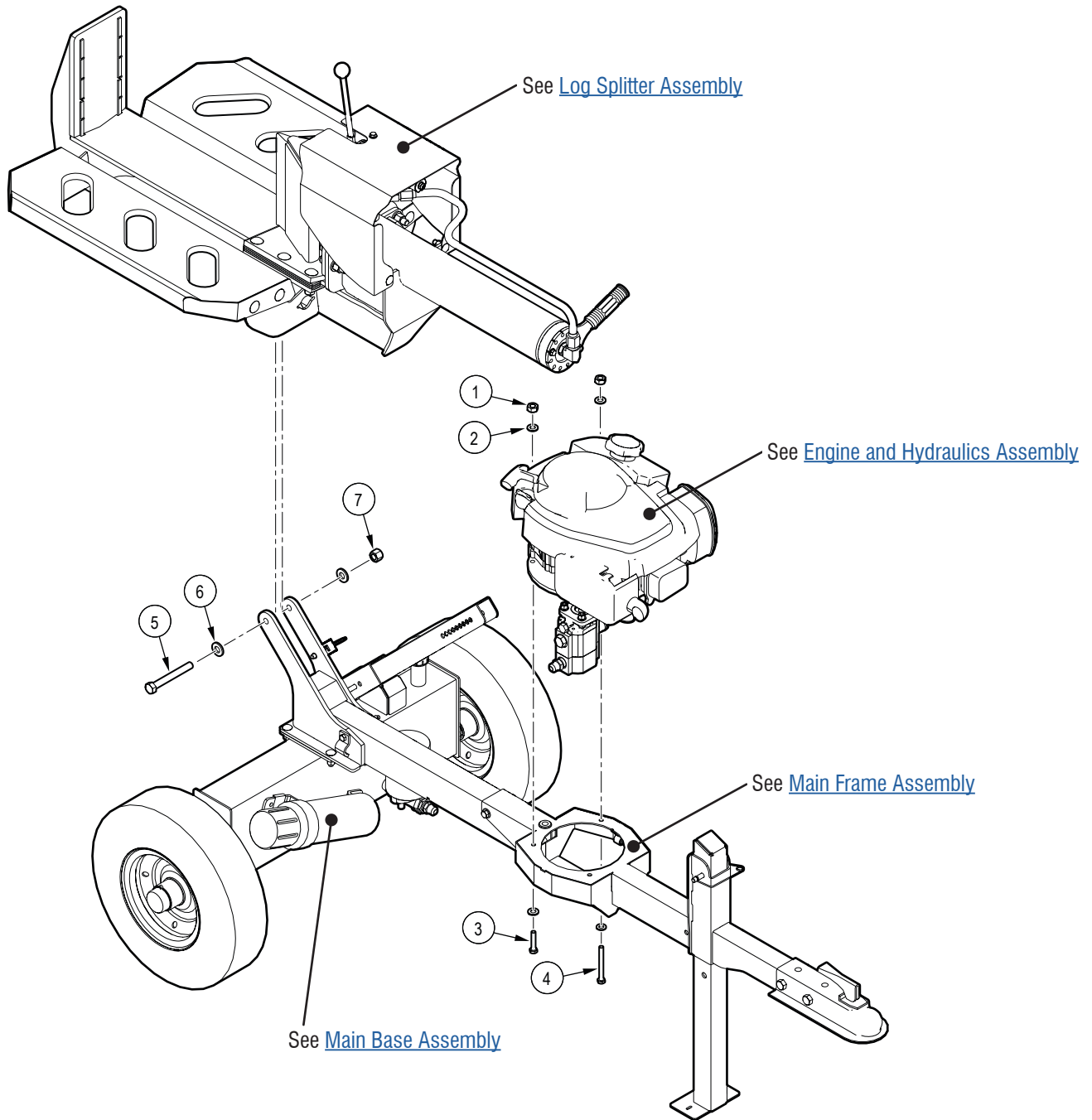

Item	Part number	Description	Quantity
1	Z77253	Hex Lock Nut M8 x 1.25 mm	3
2	Z77361	DIN 125 Washer, M10	6
3	Z77151	Hex Bolt M8 x 1.25 mm x 40 mm	2
4	Z77156	Hex Bolt M8 x 1.25 mm x 75 mm	1

Item	Part number	Description	Quantity
5	Z71540	Hex Bolt 1/2" NC x 4	1
6	Z73151G8	SAE Washer 1/2" Grade 8	2
7	Z72251	Hex Lock Nut 1/2" NC	1

# Log Splitter Assembly

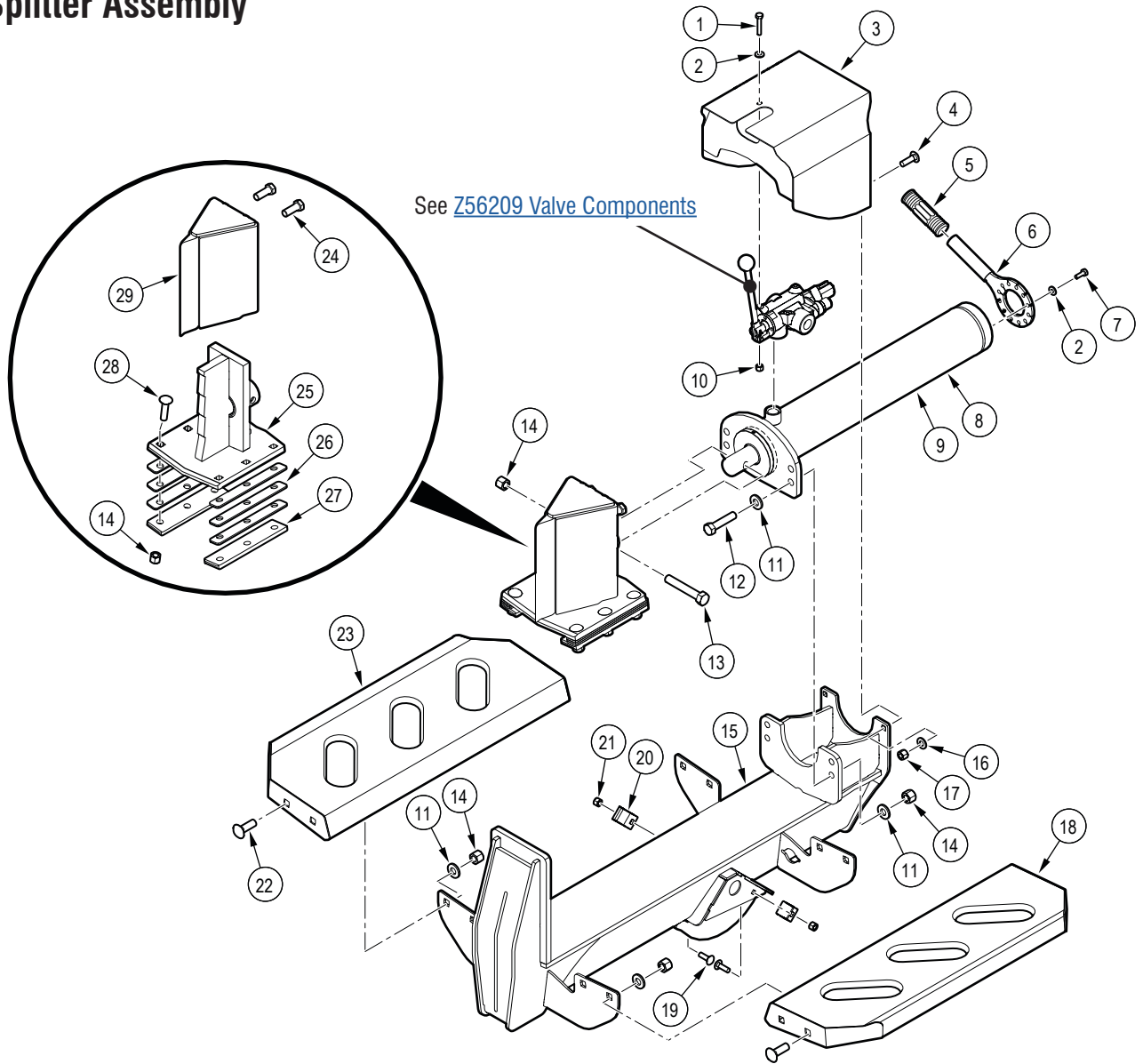

Item	Part number	Description	Quantity
1	Z71115	Hex Bolt 1/4" NC x 1-1/2"	1
2	Z73111G8	SAE Washer 1/4" Grade 8	3
3	2074W616	Valve Guard	1
4	Z76232	Carriage Bolt 3/8" NC x 1-1/4"	2
5	Z19321	Handle Grip 1"	1
6	2074W513	Handle	1
7	Z71107	Hex Bolt 1/4" NC x 3/4"	2
8	2074C501	Cylinder 3.5" x 19" x 1-1/2"	1
9	SLK-3515	Cylinder Seal Kit (not shown)	1
10	Z72211	Hex Lock Nut 1/4" NC	1
11	Z73151G8	SAE Washer 1/2" Grade 8	16
12	Z71522	Hex Bolt 1/2" x 2-1/4"	4
13	Z71530	Hex Bolt 1/2" NC x 3"	1
14	Z72251	Hex Lock Nut 1/2" NC	19
15	2074W502	Split Bed	1

Item	Part number	Description	Quantity
16	Z73131G8	SAE Washer 3/8" Grade 8	2
17	Z72231	Hex Lock Nut 3/8" NC	2
18	2074W017	Log Shelf	1
19	Z76225	Carriage Bolt 5/16" NC x 1"	2
20	6011L128	Hose Clamp 1" x 3/8"	2
21	Z72221	Hex Lock Nut 5/16" NC	2
22	Z76251	Carriage Bolt 1/2" NC x 1-1/2"	8
23	2074W018	Log Shelf	1
24	Z71992G8	Hex Bolt 9/16" NF x 1-1/2" G8	2
25	2074W609	Wedge Base	1
26	2074L726	Spacer 0.150"	6
27	2074L724	Linear Bearing 3/8"	2
28	Z76255	Carriage Bolt 1/2" NC x 2"	6
29	2074W610	Two-Way Wedge	1

# Main Frame Assembly

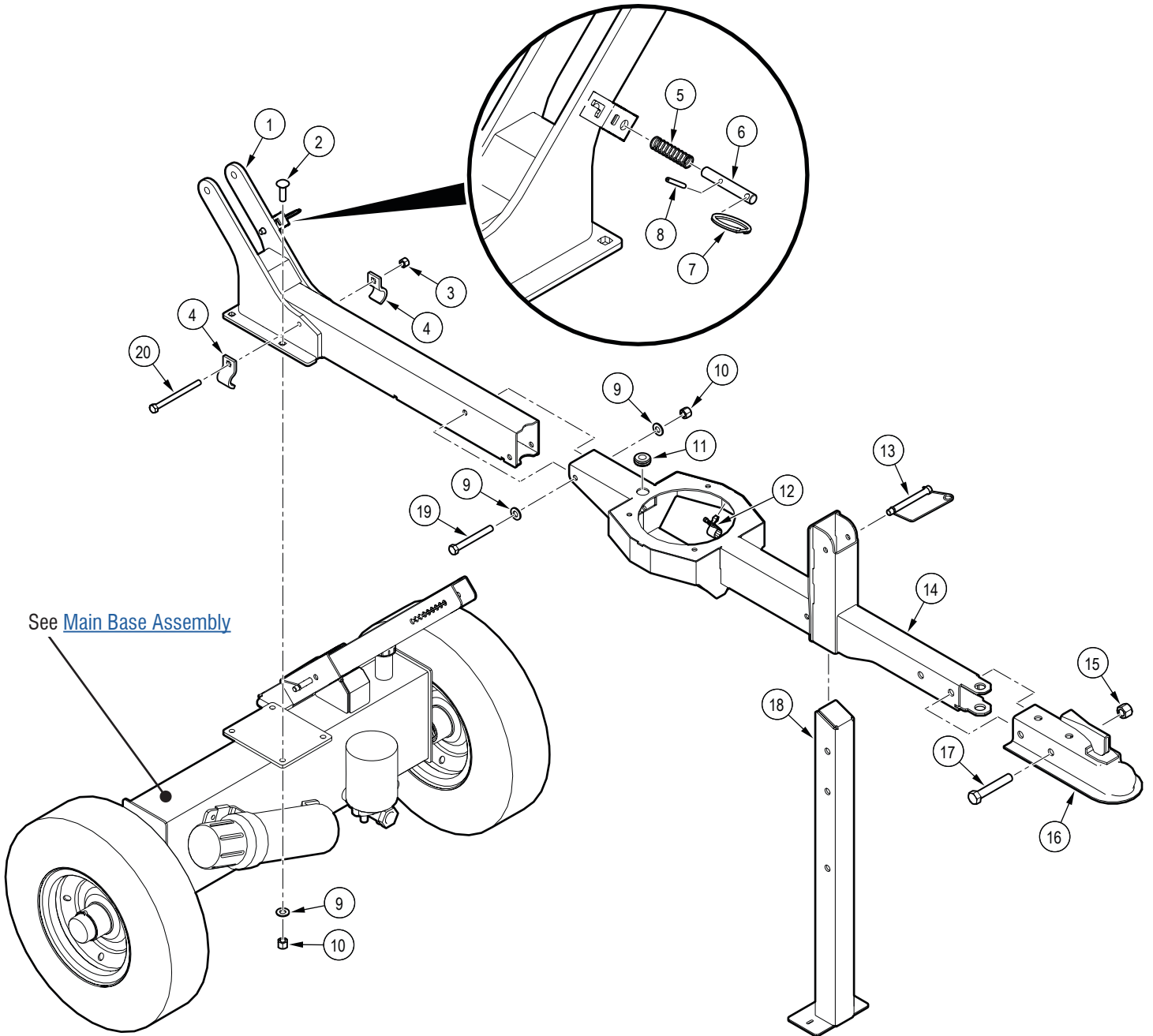

Item	Part number	Description	Quantity
1	2074W516	Pivot Base	1
2	Z76232	Carriage Bolt 3/8" NC x 1-1/4"	4
3	Z72221	Hex Lock Nut 5/16" NC	1
4	6011L128	Hose Clamp 1" x 3/8"	2
5	Z32202	Comp Spring, 0.48" OD x 1.75" x 0.045"	1
6	2074M204	Latch Pin	1
7	Z19924	Zinc-Plated Steel Split Ring 1-1/2" OD, 1-1/4" ID, 3/16" Thick	1
8	Z14141	Roll Pin, 5/32" x 1-1/8"	1
9	Z73131G8	SAE Washer 3/8" Grade 8	8
10	Z72231	Hex Lock Nut 3/8" NC	6

Item	Part number	Description	Quantity
11	Z62830	Rubber Grommet 1/2" x 1/8"	1
12	Z62828	Cable Clamp P-Type Push In 1/2"	1
13	Z12433	Snap Lock Pin 3/8" x 3"	1
14	2074W517	Trailer Tongue	1
15	Z72251	Hex Lock Nut 1/2" NC	2
16	Z91614	Hitch Coupler 2" Ball x 2" x 3,500 lb	1
17	Z71530	Hex Bolt 1/2" NC x 3"	2
18	2074L166	Jack Stand Base	1
19	Z71332	Hex Bolt 3/8" NC x 3-1/4"	2
20	Z71240	Hex Bolt 5/16" NC x 4"	1

# Main Base Assembly

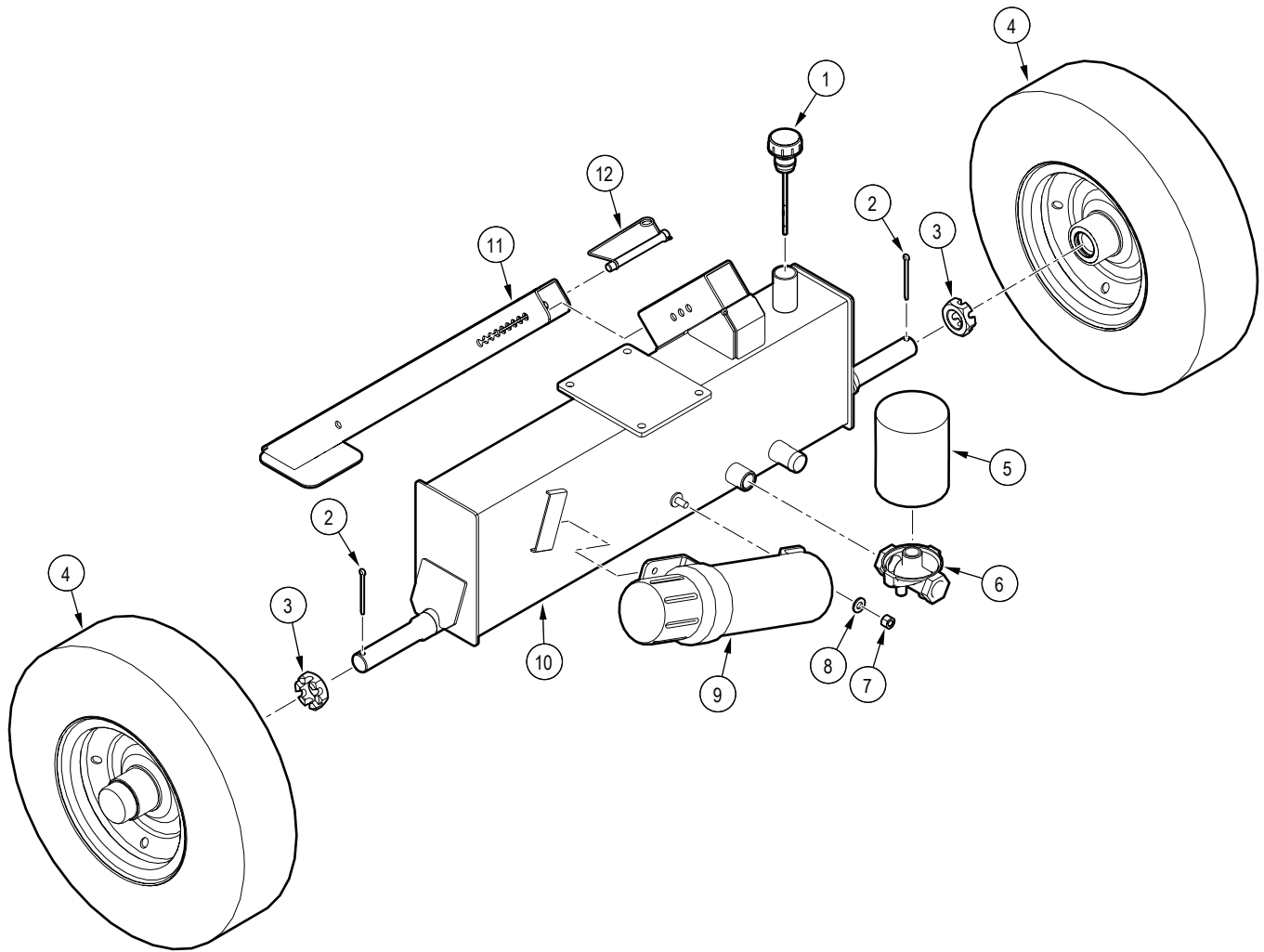

Item	Part number	Description	Quantity
1	Z55402	Vented Plug Dipstick x 5"	1
2	Z12341	Cotter Pin 3/16" X 2"	2
3	Z72691	Castle Nut 1" NF x 9/16" Thick	2
4	Z91334	Wheel 4.80-8 LRB 6PR 1" Bearing	2
5	Z55301	Particulate Filter FP12	1
6	Z55302	Filter Cap, MP12 x FP12	1

Item	Part number	Description	Quantity
7	Z72221	Hex Lock Nut 5/16" NC	1
8	Z73122G8	SAE Washer 5/16" Grade 8	1
9	Z96503	Document Tube 3-1/2" Short	1
10	2074W505	Hydraulic Fluid Reservoir	1
11	2074L588	Support Stand Base	1
12	Z12433	Snap Lock Pin 3/8" x 3"	1

# Engine and Hydraulics Assembly

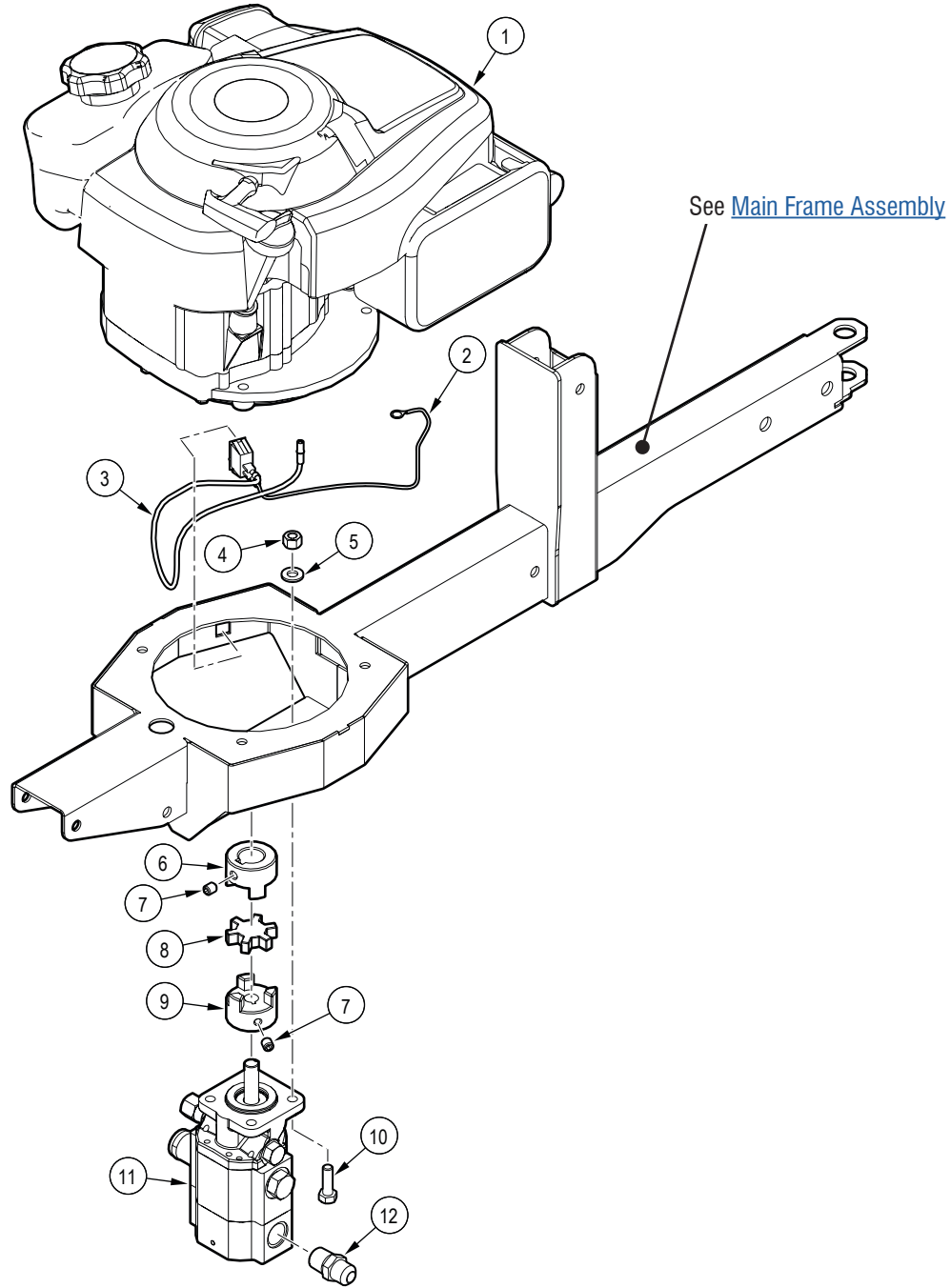

Item	Part number	Description	Quantity
1	Z47766	Briggs & Stratton 5.8 hp (190 cc) Engine	1
2	2074F010	Engine Ground Wire	1
3	2074F009	WXT15V Switch Wire	1
4	Z72221	Hex Lock Nut 5/16" NC	4
5	Z73122G8	SAE Washer 5/16" Grade 8	4
6	Z46433	Shaft Coupling L075 x 7/8" with 3/16" Keyway	1

Item	Part number	Description	Quantity
7	Z74121	Set Screw 5/16" NC	2
8	Z46408	Spider L075	1
9	Z46410	Shaft Coupling L075 x 1/2"	1
10	Z71210	Hex Bolt 5/16" NC x 1"	4
11	Z53402	Two-Stage Pump 11 gpm	1
12	Z51442	Straight MJIC x MP 0808	1



# Z56209 Valve Components

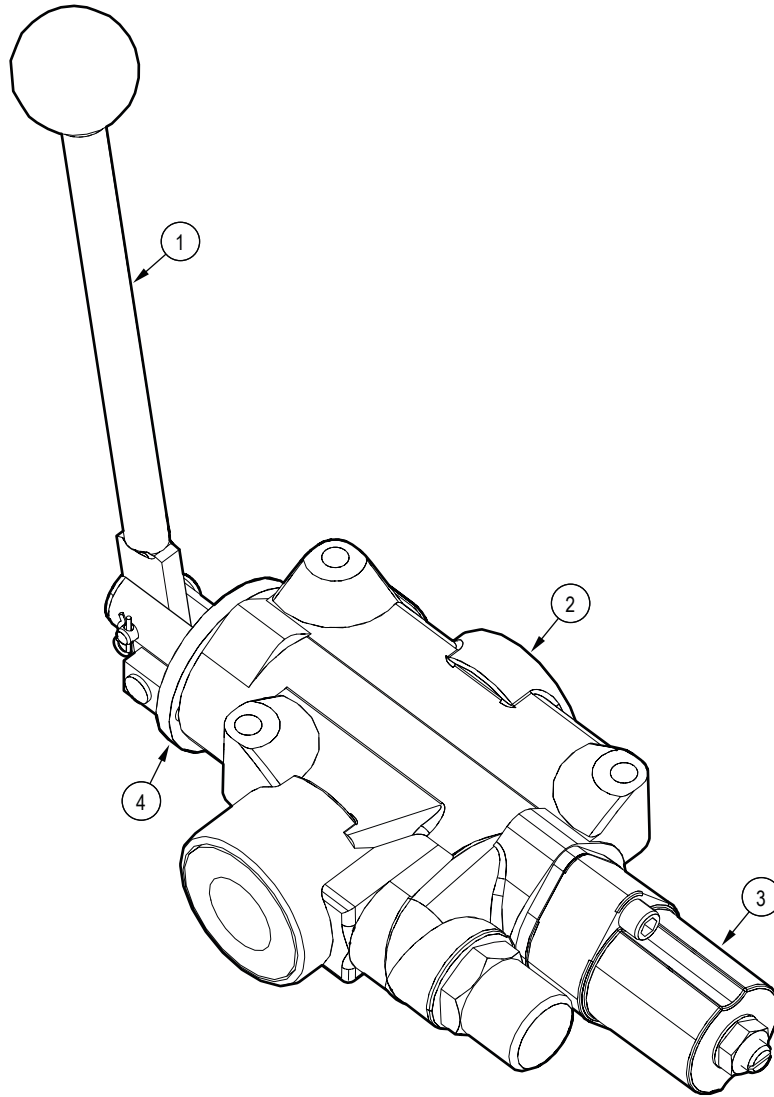

Item	Part number	Description	Quantity
1	SDC-HJ	Handle kit	1
2	LSJRS-K	General seal kit	1
3	LS-RK	Kick-out assembly with spool	1
4	P2322	Clevis bracket	1

# Hydraulic Circuit

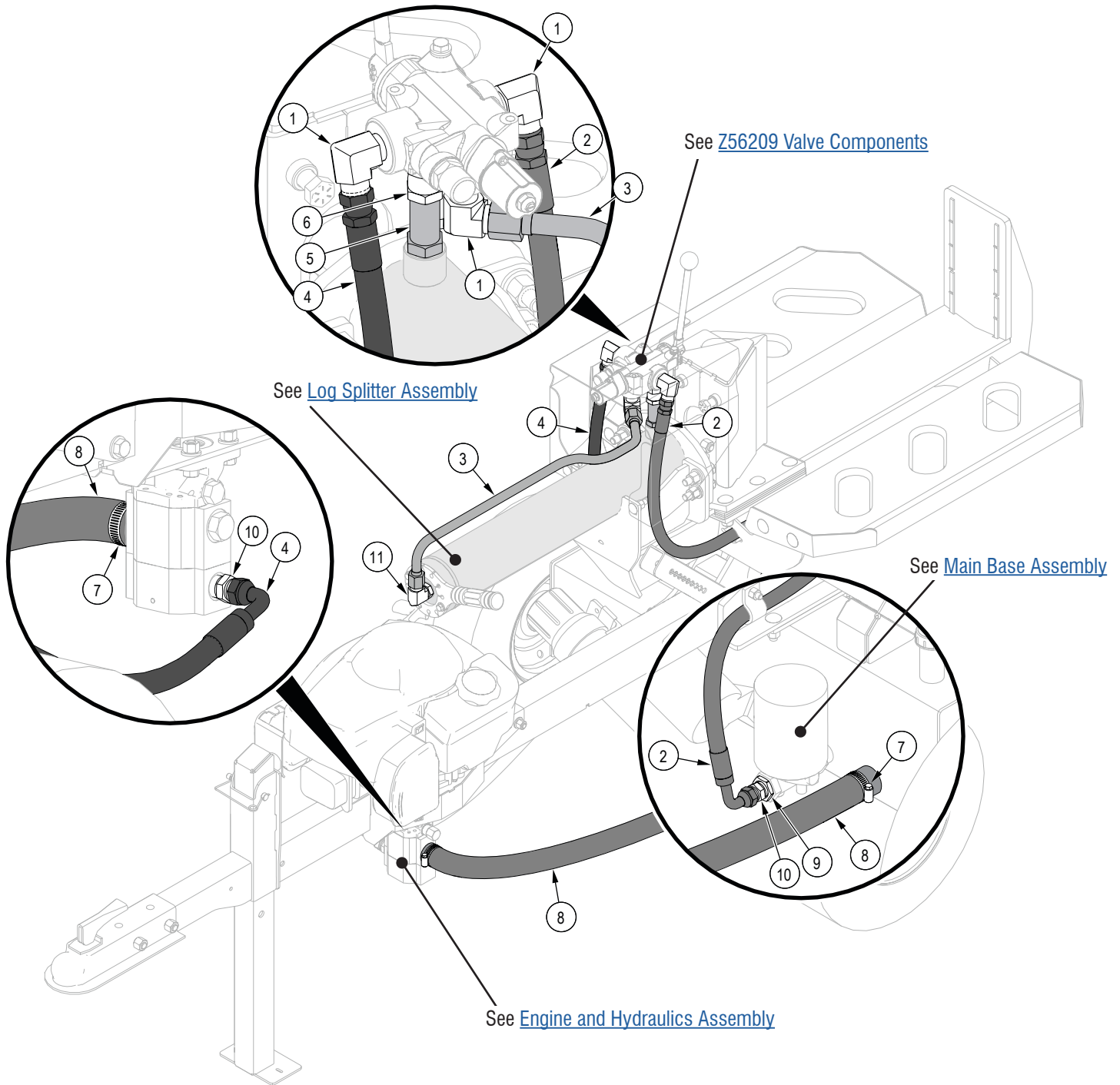

Item	Part number	Description	Quantity
1	Z514503	Elbow 90 degrees MJIC x MP 1008	3
2	2074F502	Hose 1/2" FJIC 90 08 x FJIC08 x 48" SC	1
3	2074F505	Tube 5/8" FJICX10 x FJICX10	1
4	2074F503	Hose 1/2" FJICX 90 08 x FJICX08 x 63-1/2" SC	1
5	Z516424	Straight MJIC x MORB 1010 Long	1

Item	Part number	Description	Quantity
6	Z51516	Straight MP x FJICX 0810	1
7	Z79401	Hose Clamp SAE #16 (1-1/2")	2
8	2074F504	Suction Hose 1" x 30"	1
9	Z51221	Straight MP x FP 1208	1
10	Z51442	Straight MJIC x MP 0808	2
11	Z516502	Elbow 90 degrees MJIC x MORB 1010	1

# Label Locations

**IMPORTANT!** If you replace a part that has a safety label on it, you must apply a new safety label. Immediately replace safety labels that are damaged, have been removed, or are illegible.

Contact your local Wallenstein Equipment dealer or distributor to order a safety label kit. Labels are not sold individually.

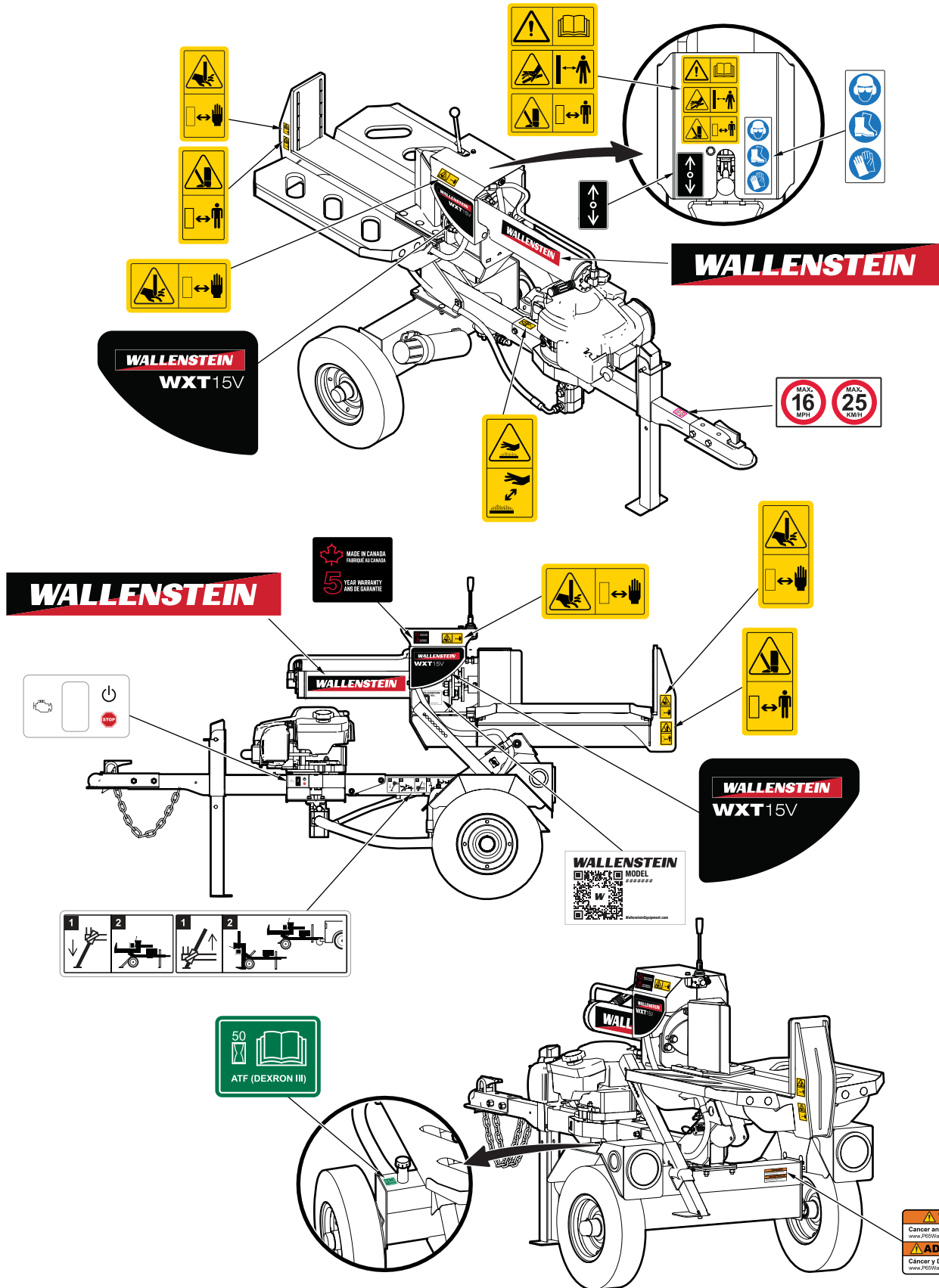

## Accessories

For price and availability, contact your local Wallenstein dealer or go to [WallensteinEquipment.com](http://WallensteinEquipment.com).

For accessory installation instructions, go to [WallensteinEquipment.com/Support.aspx](http://WallensteinEquipment.com/Support.aspx), and then select **Accessories**.

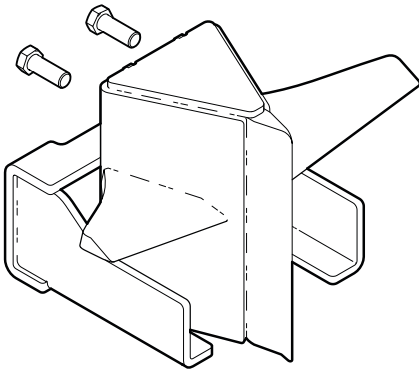

### Four-way wedge with log stripper W4302

Split logs into four pieces with a single stroke.

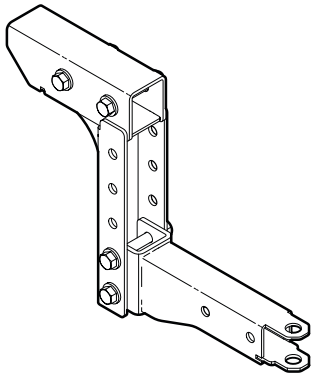

### Ladder hitch W4304

Align the hitch with your tow vehicle for the optimum towing height.

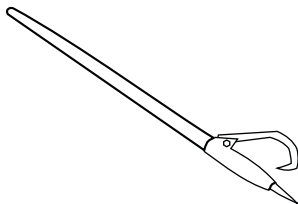

### 48" log peavy Z99001

Use a log peavy to move logs and prevent injury to your hands.



### All weather log splitter cover W4204

Heavy duty industrial material, made in Canada. Protects your log splitter from harsh elements.

## Bolt Torque

**IMPORTANT!** If you replace hardware, use fasteners of the same grade.

**IMPORTANT!** The torque specifications in these tables are for non-greased or non-oiled threads. Do not grease or oil fastener threads unless otherwise indicated. When using a thread lock, increase the specified torque 5%.



Bolt grades are identified by the marks on the bolt head.

The bolt torque specification tables provide the correct torque settings for common bolts and capscrews. Tighten all bolts to the torque that is specified in the table, unless otherwise indicated. Check the bolt tightness periodically.

### Imperial Bolt Torque Specifications

Bolt Diameter	Torque					
	SAE Gr. 2		SAE Gr. 5		SAE Gr. 8	
	lbf•ft	N•m	lbf•ft	N•m	lbf•ft	N•m
1/4 inch	6	8	9	12	12	17
5/16 inch	10	13	19	25	27	36
3/8 inch	20	27	33	45	45	63
7/16 inch	30	41	53	72	75	100
1/2 inch	45	61	80	110	115	155
9/16 inch	60	95	115	155	165	220
5/8 inch	95	128	160	215	220	305
3/4 inch	165	225	290	390	400	540
7/8 inch	170	230	420	570	650	880



SAE Gr. 2



SAE Gr. 5



SAE Gr. 8

### Metric Bolt Torque Specifications

Bolt Diameter	Torque			
	Gr. 8.8		Gr. 10.9	
	lbf•ft	N•m	lbf•ft	N•m
M3	0.4	0.5	1.3	1.8
M4	2.2	3	3.3	4.5
M6	7	10	11	15
M8	18	25	26	35
M10	37	50	52	70
M12	66	90	92	125
M14	83	112	116	158
M16	166	225	229	310
M20	321	435	450	610
M30	1,103	1,495	1,550	2,100



8.8



10.9

## Hydraulic Fitting Torque

Tighten flare-type tube fittings:

1. Check the flare and flare seat for defects that might cause leaks.
2. Align the tube with the fitting before tightening.
3. Hand-tighten the swivel nut until it is snug.
4. To prevent the tube from twisting, use two wrenches. Place one wrench on the connector body and tighten the swivel nut with the second wrench. Torque the fitting to the correct specification.

If a torque wrench is not available, use the flats from finger tight (FFFT) method.

Hydraulic Fitting Torque Specifications					
Tube size OD	Hex size across flats	Torque		Flats from finger tight	
		lbf•ft	N•m	Flats	Turns
3/16	7/16	6	8	2	1/6
1/4	9/16	11–12	15–17	2	1/6
5/16	5/8	14–16	19–22	2	1/6
3/8	11/16	20–22	27–30	1-1/4	1/6
1/2	7/8	44–48	59–65	1	1/6
5/8	1	50–58	68–79	1	1/6
3/4	1-1/4	79–88	107–119	1	1/8
1	1-5/8	117–125	158–170	1	1/8

These specifications are for fittings that are not lubricated.



A series of 25 horizontal lines spanning the width of the page, providing a space for handwritten notes or calculations.



**MAKING WORK FEEL MORE LIKE PLAY™**

[WallensteinEquipment.com](http://WallensteinEquipment.com)

