



EMB Manufacturing Inc.
4144 Boomer Line · St. Clements, On · N0B 2M0 · Canada
Ph: (519) 699-9283 · Fax: (519) 699-4146
www.embmfg.com

WP630 Wood Processor

Parts Manual

S/N 640028 & After

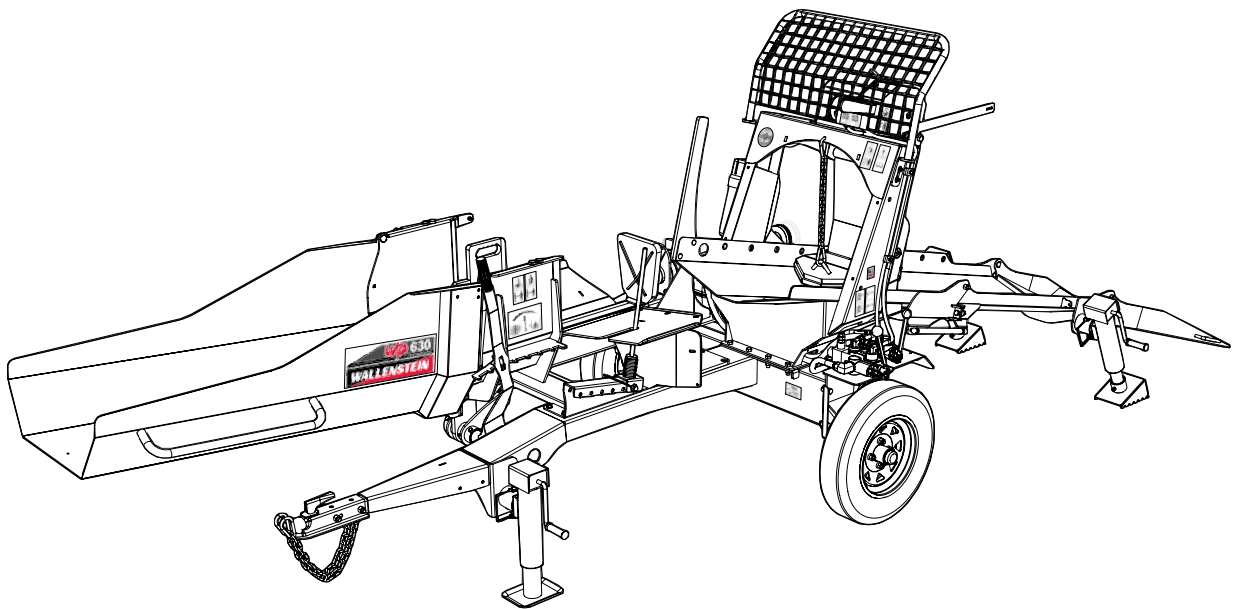

Refer to the operators
manual for safe opera-
tion and maintainance

2072T100 WP630 Parts Manual
Rev C 270315

Table of Contents

BOLT TORQUE	3
HYDRAULIC FITTING TORQUE	4
SPLITTER CHUTE ASS'Y	5
LEAD IN CHUTE ASS'Y	6
SPLITTER CRADLE ASS'Y	7
LOG CHUTE ASS'Y	8
RUNNING GEAR	9
HUB ASSEMBLY DETAIL	10
ENGINE & PUMP ASS'Y	11
HYDRAULIC LINES	12
HYDRAULIC SPLITTER ASS'Y	13
HYDRAULIC VALVES	14
HYDRAULIC CYLINDER	15
HYDRAULIC CYLINDER SEAL KIT #SLK-4525	15
HYDRAULIC WINCH	16
WINCH DRUM DETAIL	17
WINCH FAIRLEAD DETAIL	17
LABELS	18
HYDRAULIC SCHEMATIC	19
ACCESSORIES	20

Foreword

EMB Mfg. has prepared this parts manual to assist customers in ordering quality OEM replacement parts.

Proper and regular service and replacing old, worn or broken parts with the correct Wallenstein parts are essential to prolonging the life of your Wallenstein product. Please refer to this manual before ordering any replacement parts.

All information contained in this parts manual is based on the latest product specification available at the time of printing this manual. If your product differs from the specifications contained within this manual contact EMB Mfg. for information.

EMB reserves the right to alter specifications on their products at any time.

Reproduction of this parts manual of any kind is prohibited without prior written permission from EMB Mfg.



Refer to the operators manual for safe operation and maintainance

For parts and information please contact your dealer. If your dealer is no longer available please go to our website: <http://www.embmfg.com> and click on "FIND A DEALER NEAR YOU" for information on a local dealer.

Bolt Torque

CHECKING BOLT TORQUE

The tables shown below give correct torque values for various bolts and capscrews. Tighten all bolts to the torques specified in chart unless otherwise noted. Check tightness of bolts periodically, using bolt torque chart as a guide. Replace hardware with the same strength bolt.

Torque figures indicated above are valid for non-greased or non-oiled threads and heads unless otherwise specified. Therefore, do not grease or oil bolts or capscrews unless otherwise specified in this manual. When using locking elements, increase torque values by 5%.

* Torque value for bolts and capscrews are identified by their head markings.

ENGLISH TORQUE SPECIFICATIONS

Bolt Diameter "A"	Bolt Torque*					
	SAE 2 (N.m) (lb-ft)		SAE 5 (N.m) (lb-ft)		SAE 8 (N.m) (lb-ft)	
1/4"	8	6	12	9	17	12
5/16"	13	10	25	19	36	27
3/8"	27	20	45	33	63	45
7/16"	41	30	72	53	100	75
1/2"	61	45	110	80	155	115
9/16"	95	60	155	115	220	165
5/8"	128	95	215	160	305	220
3/4"	225	165	390	290	540	400
7/8"	230	170	570	420	880	650
1"	345	225	850	630	1320	970



METRIC TORQUE SPECIFICATIONS

Bolt Diameter "A"	Bolt Torque*			
	8.8 (N.m) (lb-ft)		10.9 (N.m) (lb-ft)	
M3	.5	.4	1.8	1.3
M4	3	2.2	4.5	3.3
M5	6	4	9	7
M6	10	7	15	11
M8	25	18	35	26
M10	50	37	70	52
M12	90	66	125	92
M14	140	103	200	148
M16	225	166	310	229
M20	435	321	610	450
M24	750	553	1050	774
M30	1495	1103	2100	1550
M36	2600	1917	3675	2710

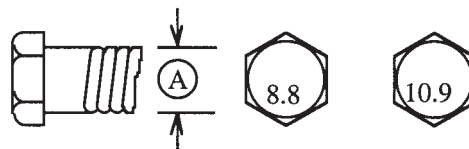

Hydraulic Fitting Torque

Tightening Flare Type Tube Fittings *

1. Check flare and flare seat for defects that might cause leakage.
2. Align tube with fitting before tightening.
3. Lubricate connection and hand tighten swivel nut until snug.
4. To prevent twisting the tube(s), use two wrenches. Place one wrench on the connector body and with the second tighten the swivel nut to the torque shown.

Tube Size OD	Nut Size Across Flats	Torque Value*		Recommended Turns To Tighten (After Finger Tightening)	
		(N.m)	(lb-ft)	(Flats)	(Turn)
3/16	7/16	8	6	1	1/6
1/4	9/16	12	9	1	1/6
5/16	5/8	16	12	1	1/6
3/8	11/16	24	18	1	1/6
1/2	7/8	46	34	1	1/6
5/8	1	62	46	1	1/6
3/4	1-1/4	102	75	3/4	1/8
7/8	1-3/8	122	90	3/4	1/8

The torque values shown are based on lubricated connections as in reassembly.

Splitter Chute Ass'y

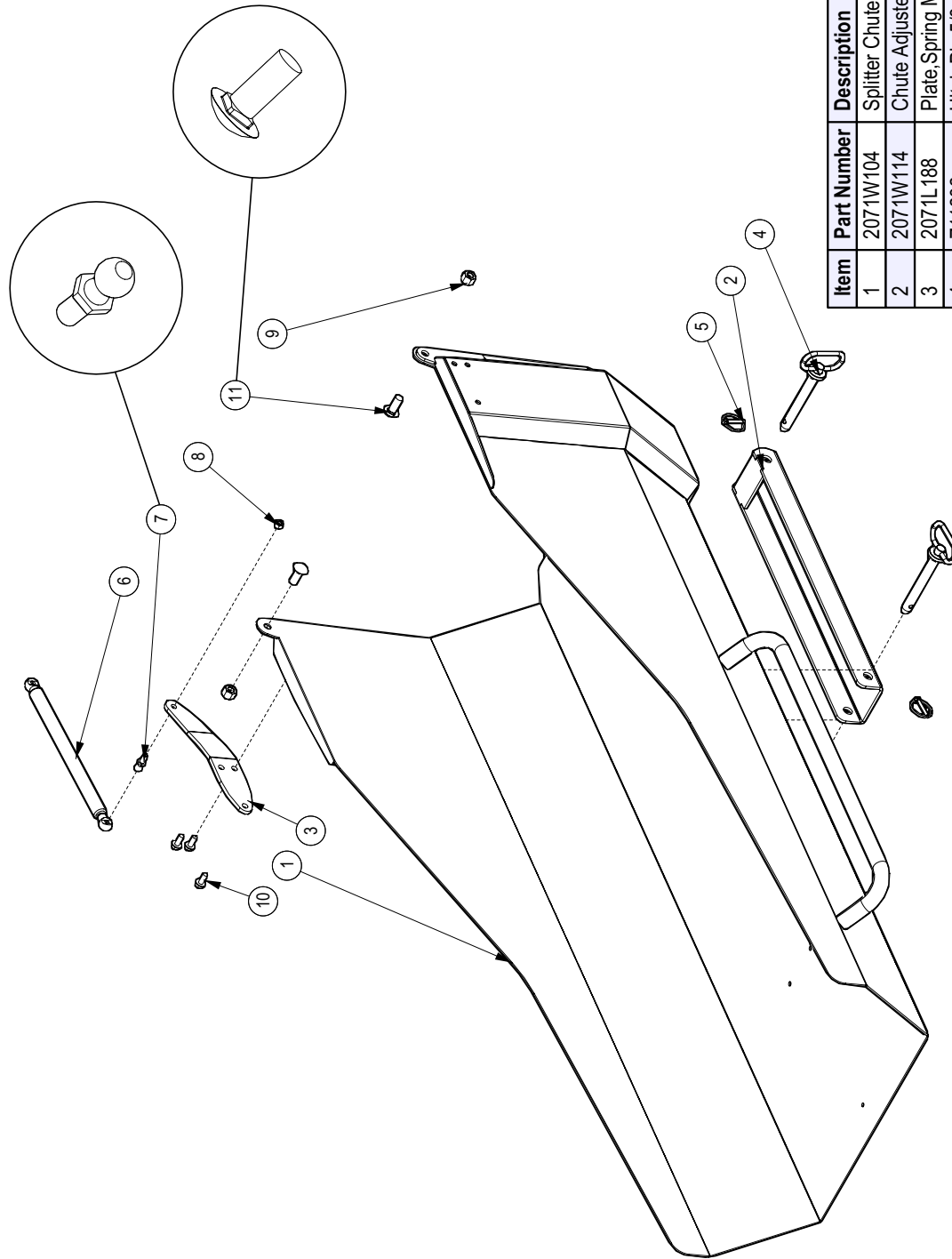

Item	Part Number	Description	Qty
1	2071W104	Splitter Chute	1
2	2071W114	Chute Adjuster	1
3	2071L188	Plate, Spring Mount	1
4	Z11232	Hitch Pin 5/8 x 4-1/4	2
5	Z12110	Latch Pin 3/16	2
6	Z34203	Gas Spring, 10mm x 8.44 Stroke	1
7	Z34204	Ball Stud 13mm x 5/16	1
8	Z72221	Hex Lock Nut, 5/16NC	1
9	Z72251	Hex Lock Nut, 1/2NC	2
10	Z76121	Flange Bolt, 5/16NC x 3/4	3
11	Z76259	Carriage Bolt, 1/2NC x 1-1/4	2

Lead In Chute Ass'y

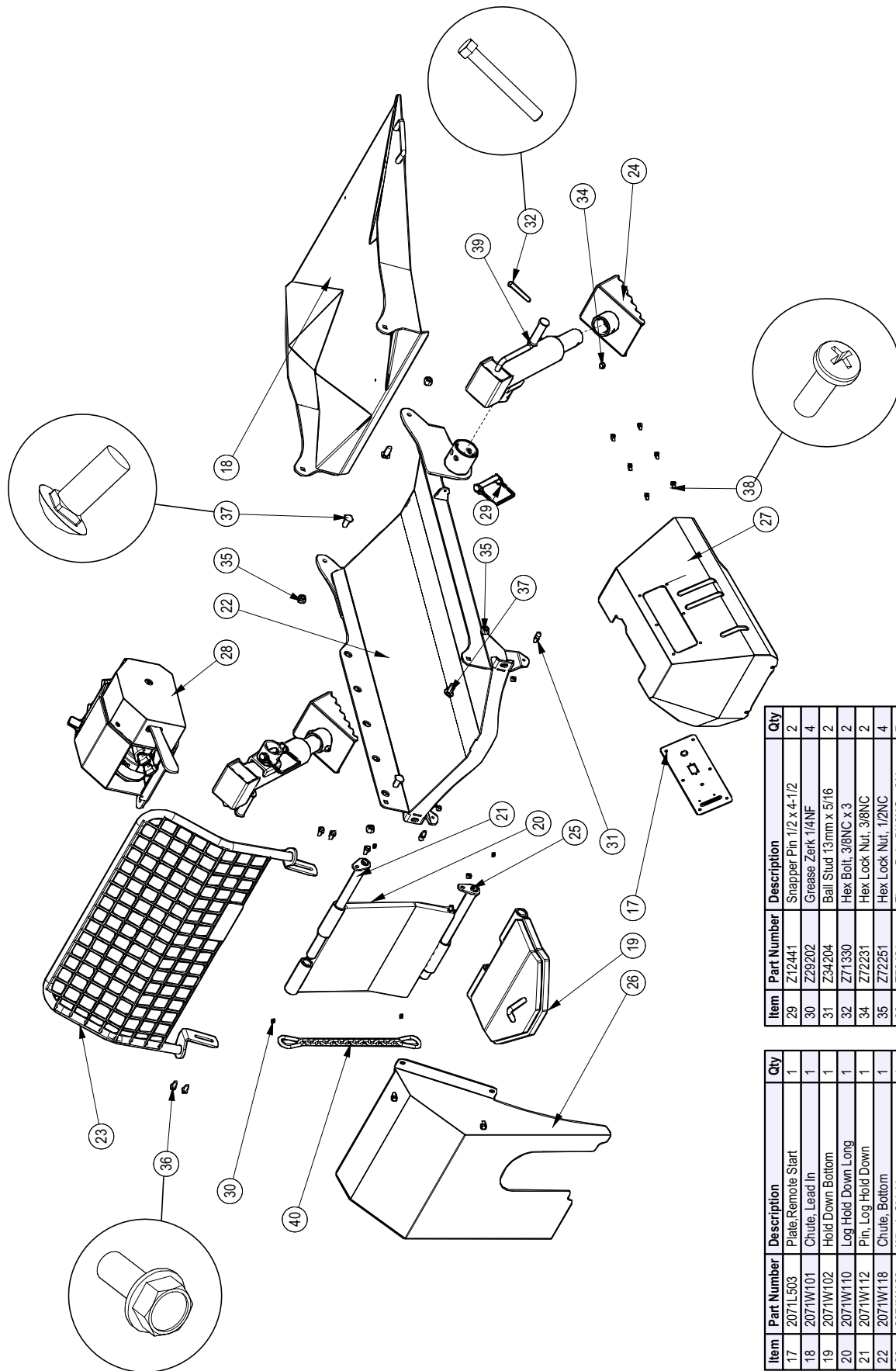

Item	Part Number	Description	Qty
29	Z12441	Snapper Pin, 1/2 x 4-1/2	2
30	Z29202	Grease Zerk 1/4NF	4
31	Z34204	Ball Stud 13mm x 5/16	2
32	Z71330	Hex Bolt, 3/8NC x 3	2
34	Z72231	Hex Lock Nut, 3/8NC	2
35	Z72251	Hex Lock Nut, 1/2NC	4
36	Z76121	Flange Bolt, 5/16NC x 3/4	7
37	Z76259	Carriage Bolt, 1/2NC x 1-1/4	4
38	Z76301	Machine Screw, 1/4-20NC x 3/4	6
39	Z91515	Side-Wind 10" Jack, No Foot	2
40	Z92311	1/4" Chain x 21"	1

Item	Part Number	Description	Qty
17	2071L503	Plate, Remote Start	1
18	2071W101	Chute, Lead In	1
19	2071W102	Hold Down Bottom	1
20	2071W110	Log Hold Down Long	1
21	2071W112	Pin, Log Hold Down	1
22	2071W118	Chute, Bottom	1
23	2071W120	Winch Shield	1
24	2071W122	Foot, Jack	1
25	2071W136	Pin, Log Hold Down	1
26	2071W137	Dust Guard	1
27	2071W505	Cover, Valve	1
28	5081A100	Hydraulic Winch Assembly	1

Splitter Cradle Ass'y

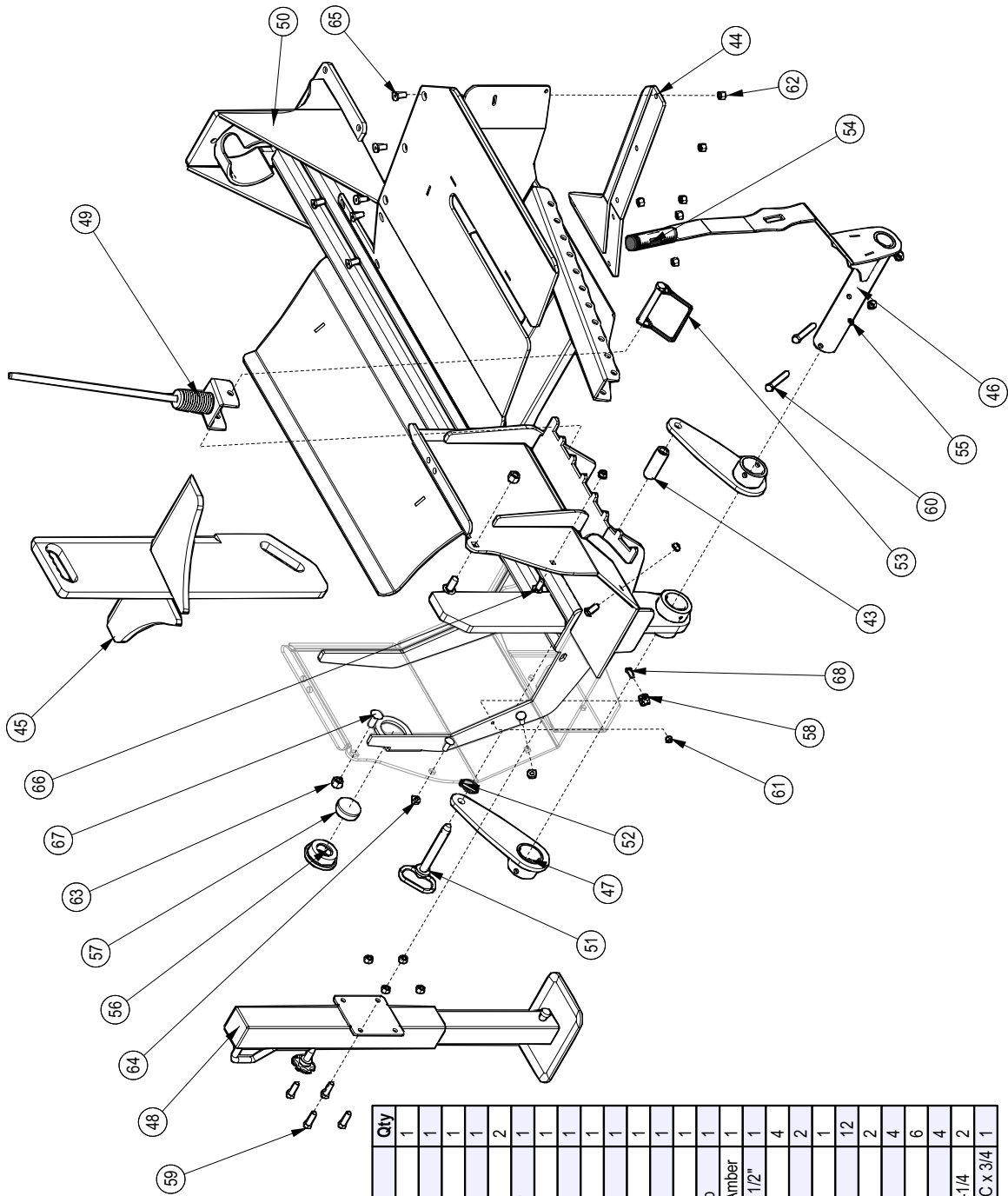

Item	Part Number	Description	Qty
43	2071M123	Roller Wedge Lift	1
44	2071S126	Edge,Log Table	1
45	2071W103	Wedge 4 Way	1
46	2071W105	Wedge Position Handle	1
47	2071W111	Arm Wedge Lifter	2
48	2071W116	Drop Leg Jack Assembly	1
49	2071W190	Log Stop Whip	1
50	2072W592	Splitter	1
51	Z11232	Hitch Pin 5/8 x 4-1/4	1
52	Z12110	Latch Pin 3/16	1
53	Z12441	Snapper Pin 1/2 x 4-1/2	1
54	Z19321	Grip, 1" x 5"	1
55	Z29202	Grease Zerk 1/4NF	1
56	Z61202	Round Grommet 2" Lamp	1
57	Z61205	Round Marker Lamp 2" Amber	1
58	Z62819	Rubberized Wire Clamp, 1/2"	1
59	Z71312	Hex Bolt, 3/8NC x 1-1/4	4
60	Z71330	Hex Bolt, 3/8NC x 3	2
61	Z72211	Hex Lock Nut, 1/4NC	1
62	Z72231	Hex Lock Nut, 3/8NC	12
63	Z72251	Hex Lock Nut, 1/2NC	2
64	Z72531	Flange Nut 3/8NC	4
65	Z75233	FHCS, 3/8NC x 1	6
66	Z76231	Carriage Bolt, 3/8NC x 1	4
67	Z76259	Carriage Bolt, 1/2NC x 1-1/4	2
68	Z78301	Machine Screw, 1/4-20NC x 3/4	1

Log Chute Ass'y

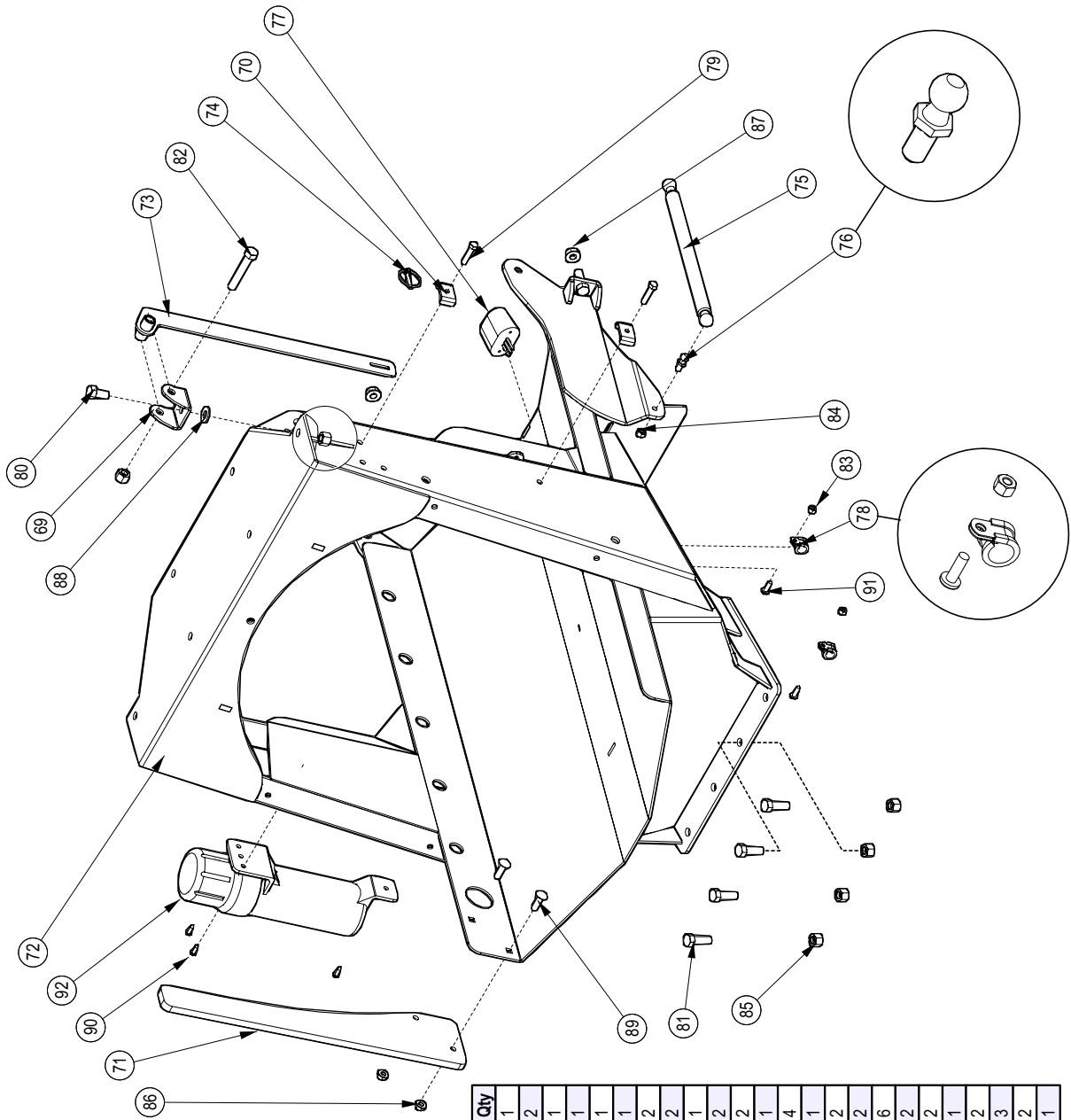

Item	Part Number	Description	Qty
68	2071L123	Clevis, Latch Mount	1
70	2071L504	Hose Clamp, 2x 1/4	2
71	2071S208	Saw Guide	1
72	2071W115	Chute, Log	1
73	2071W121	Arm, Log Chute Lock	1
74	Z12110	Latch Pin 3/16	1
75	Z34203	Gas Spring, 10mm x 8.44 Stroke	2
76	Z34204	Ball Stud 13mm x 5/16	2
77	Z61301	License Lamp	1
78	Z62819	Rubberized Wire Clamp, 1/2"	2
79	Z71215	Hex Bolt, 5/16NC x 1-1/2	2
80	Z71510	Hex Bolt, 1/2NC x 1	1
81	Z71515	Hex Bolt, 1/2NC x 1-1/2	4
82	Z71530	Hex Bolt, 1/2NC x 3	1
83	Z72211	Hex Lock Nut, 1/4NC	2
84	Z72221	Hex Lock Nut, 5/16NC	2
85	Z72251	Hex Lock Nut, 1/2NC	6
86	Z72531	Flange Nut 3/8NC	2
87	Z72551	Flange Nut 1/2NC	2
88	Z73151	Flat Washer, 1/2	1
89	Z76232	Carriage Bolt, 3/8NC x 1-1/4	2
90	Z76712	Self-tapping Screw #10	3
91	Z78301	Machine Screw, 1/4-20NC x 3/4	2
92	Z96503	Manual Tube 3-1/2 Short	1

Running Gear

em	Part Number	Description	Qty
5	Z55404	Vented Plug Dipstick x 9"	1
6	2072W010	Tongue, WP630	1
7	2072W396	Weldment, WP630 Tank Base	1
3	2072W394	Axel, Bolt On LH	1
3	2072W394H	Axel, Bolt On RH	1
2	2072W395	Valve Mount	1
1	Z91202	Assembly, 1000# 4-Bolt Hub	2
2	2071S129	Chain Bumper	1
3	Z12441	Snapper Pin 1/2 x 4-1/2	1
4	Z51192	Socket Plug MP08	1
5	Z71512	Hex Bolt, 1/2NC x 1-1/4	8
3	Z71515	Hex Bolt, 1/2NC x 1-1/2	4
7	Z71532	Hex Bolt, 1/2NC x 3-1/4	2
3	Z72251	Hex Lock Nut, 1/2NC	14
3	Z75233	FHCS, 3/8NC x 1	4
2	Z91322	5.30-12 LRC USA Trail E-Marked	2
1	Z91512	Side-Wind 10" Swivel Jack	1
2	Z91614	2" Hitch Coupler	1
3	Z92303	Safety Chain 1/4 x 2'	2

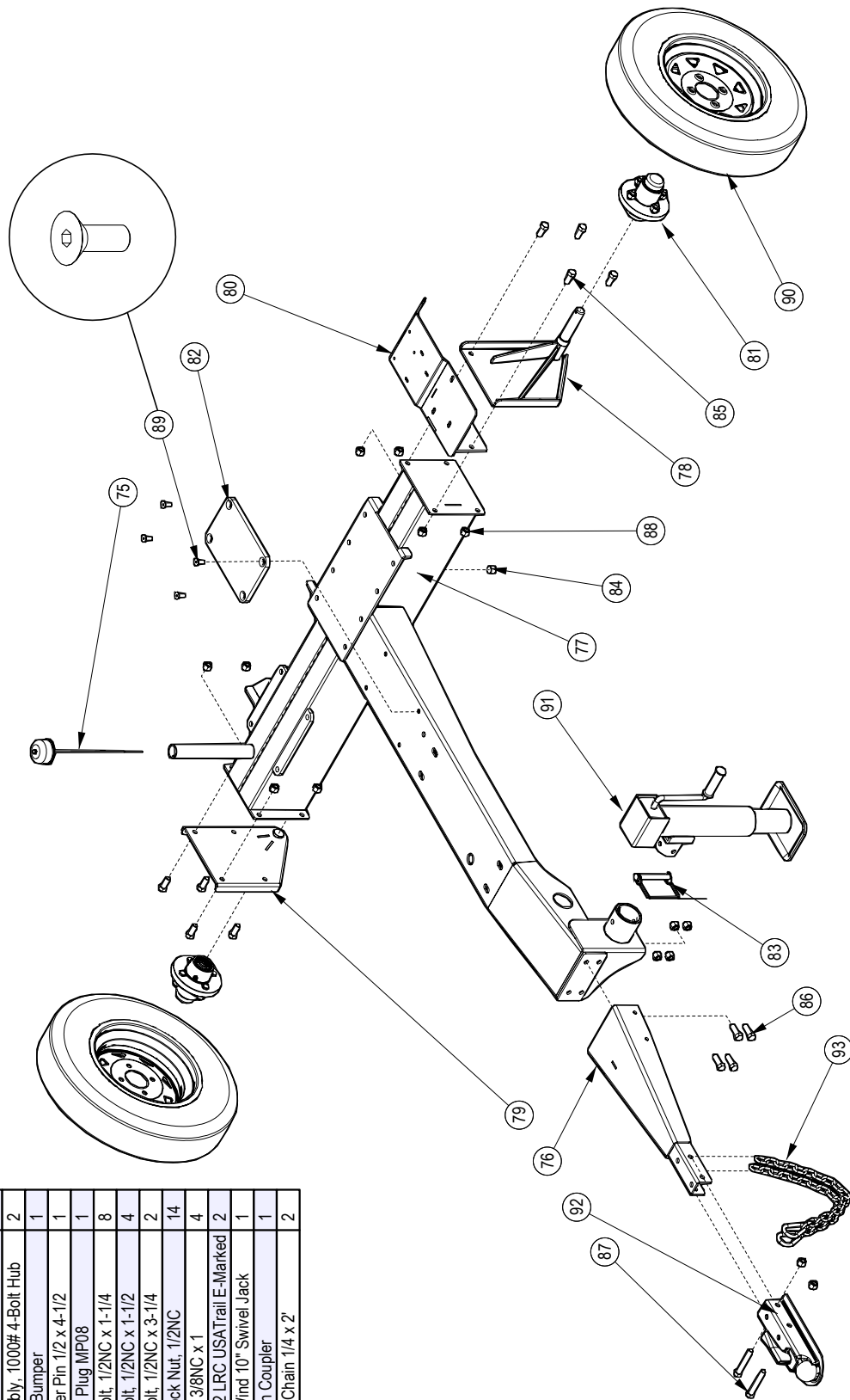

Hub Assembly Detail

Item	Part Number	Description	Qty
123	Z12322	2" x 3/16" Split Pin	1
124	Z23202	L44649 Cone, L44610 Cup	2
125	Z28302	Double Lip Seal 1-1/16 Spindle	1
126	Z29201	Grease Fitting, 1/8NPT	1
127	Z72930	Lug Nut 1/2NF	4
128	Z91201	1000# 4-Bolt Hub	1
129	Z91801	Dust Cap 1.98 Bore	1
130	Z72691	1" Castle Nut	1

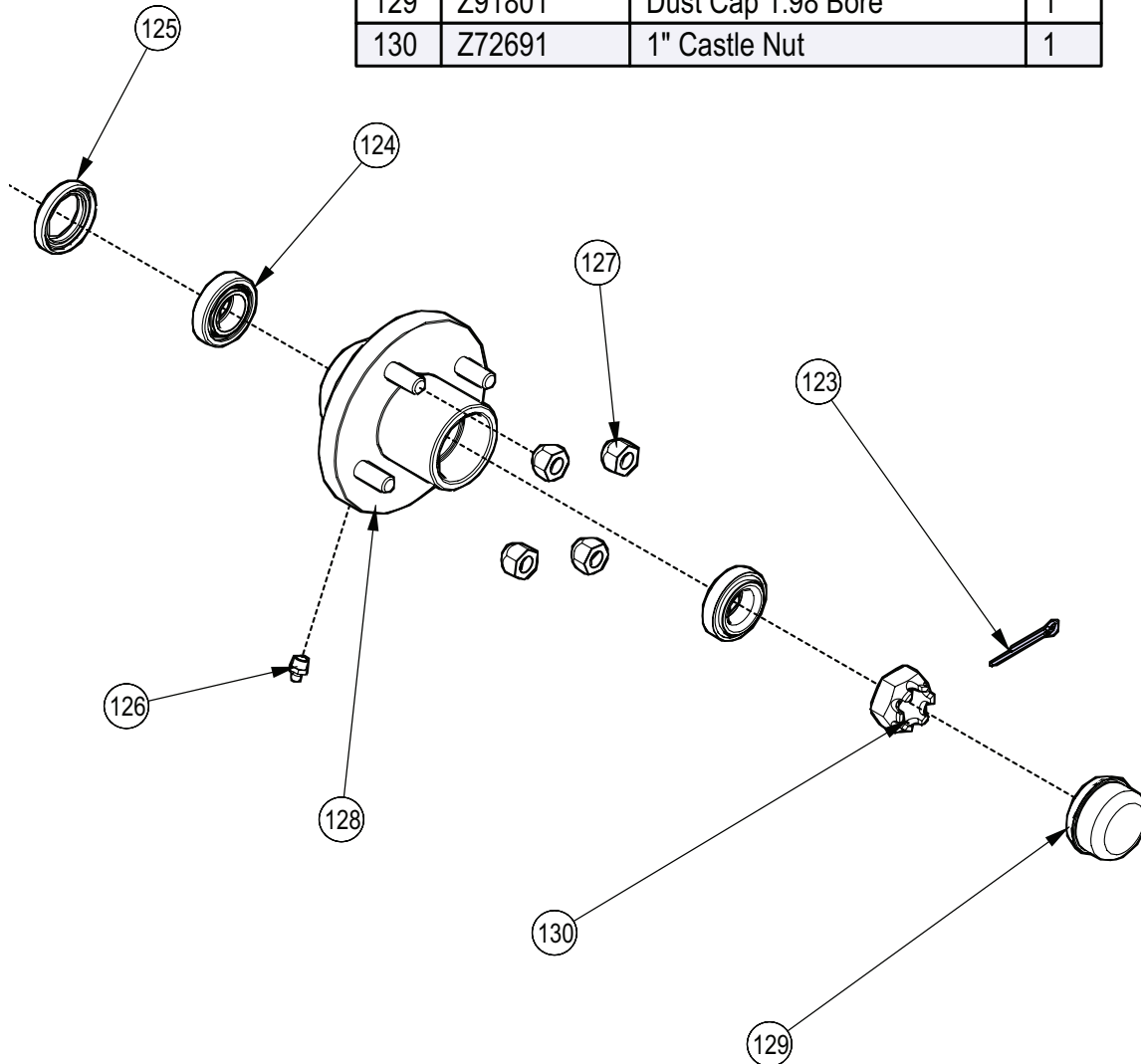

Engine & Pump Ass'y

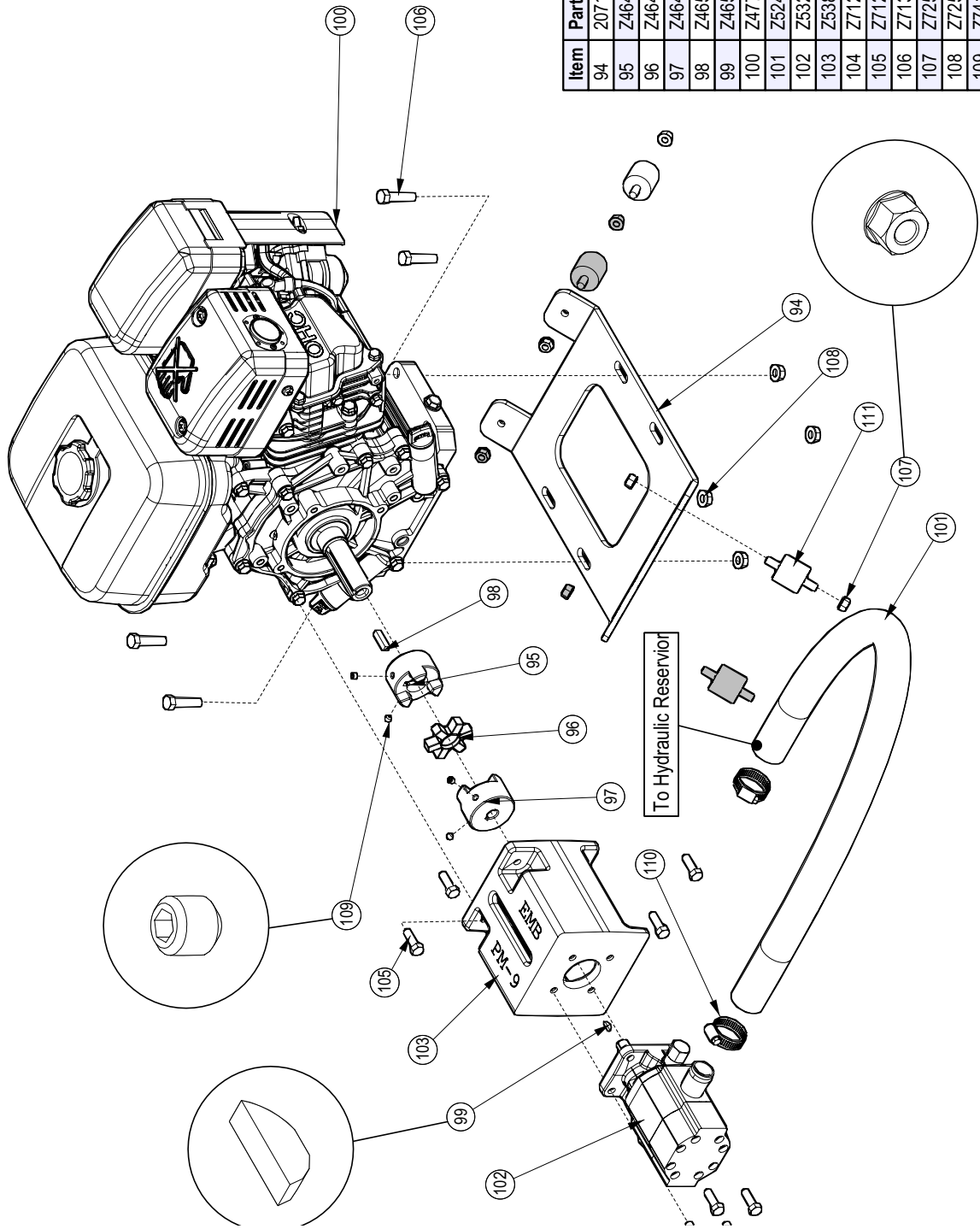

Item	Part Number	Description	Qty
94	2071L185	Plate, Engine Mount	1
95	Z46404	Shaft Coupler L095 x 1	1
96	Z46405	Coupler Spider L095	1
97	Z46409	Shaft Coupler L095 x 1/2	1
98	Z46533	Key, 1/4 x 1/4 x 1	1
99	Z46592	Woodruff Key, 1/8 x 1/2	1
100	Z47704	Subaru EX270 9hp Engine	1
101	Z62407	1" Suction Hose x 30"	1
102	Z63205	Pump, 16gpm Two-Stage	1
103	Z63802	Pump Mounting, PM-9	1
104	Z71210	Hex Bolt, 5/16NC x 1	4
105	Z71274	Hex Bolt, 5/16NF x 1	4
106	Z71315	Hex Bolt, 3/8NC x 1-1/2	4
107	Z72521	Flange Nut 5/16NC	8
108	Z72531	Flange Nut 3/8NC	4
109	Z74111	Set Screw, 1/4NC	4
110	Z79401	Hose Clamp, #16	2

Hydraulic Lines

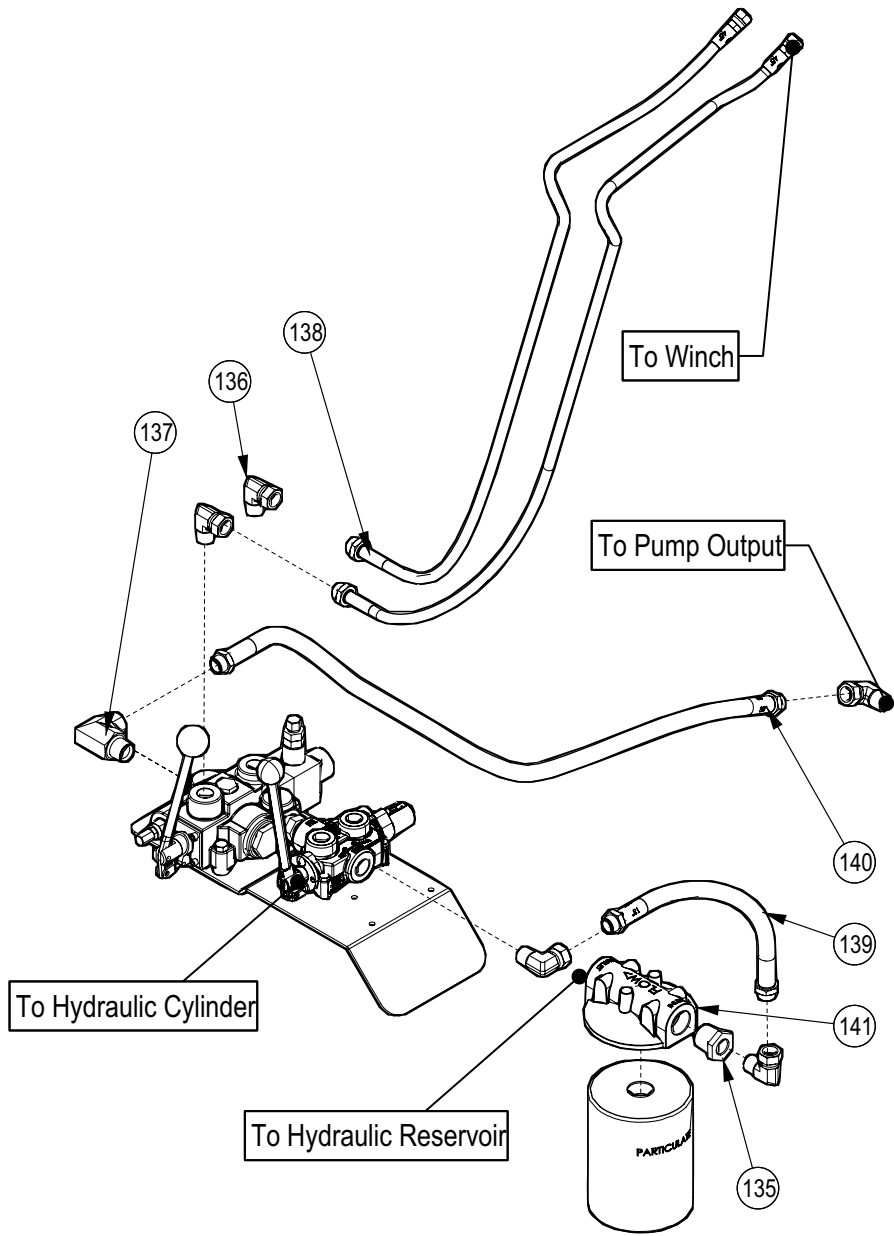

Item	Part Number	Description	Qty
135	Z51223	Reducer, MP x FP 1608	1
136	Z51331	Elbow 90 MP x FPX 0808	5
137	Z51334	Elbow 90 MP x FPX 1208	1
138	Z52123	1/4 Hose, #6FJIC x 1/2NPT x 45"	2
139	Z52301	1/2 Hose, MP08 x MP08 x 13"	1
140	Z52303	1/2 Hose, MP08 x MP08 x 33"	1
141	Z55304	Filter Cap, FP16 x FP16	1

Hydraulic Splitter Ass'y

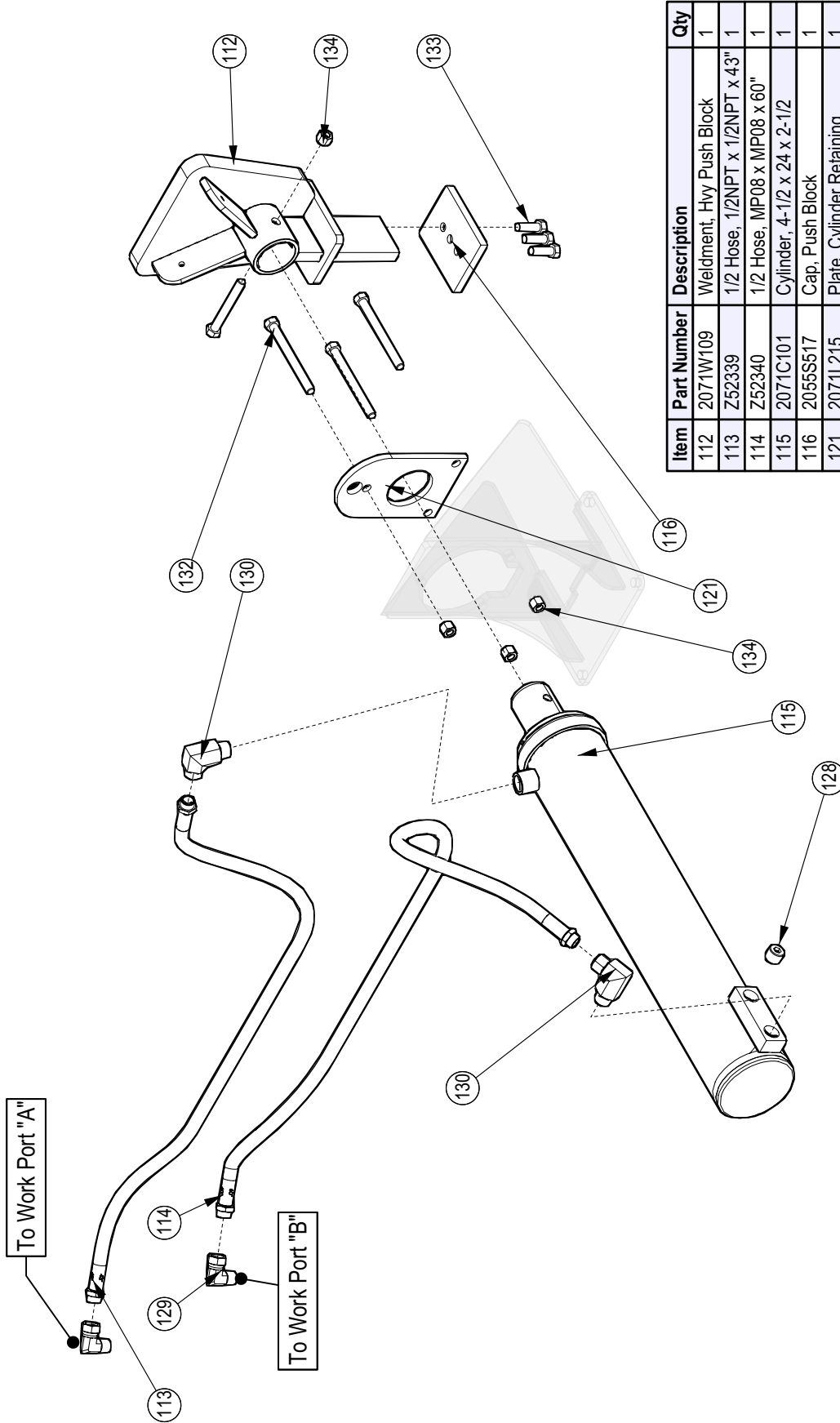

Item	Part Number	Description	Qty
112	2071W109	Weldment, Hvy Push Block	1
113	Z52339	1/2 Hose, 1/2NPT x 1/2NPT x 43"	1
114	Z52340	1/2 Hose, MP08 x MP08 x 60"	1
115	2071C101	Cylinder, 4-1/2 x 24 x 2-1/2	1
116	2055S517	Cap, Push Block	1
121	2071L215	Plate, Cylinder Retaining	1
128	Z51195	Socket Plug MP12	1
129	Z51331	Elbow 90 MP x FFX 0808	2
130	Z51334	Elbow 90 MP x FFX 1208	2
132	Z71555	Hex Bolt, 1/2NC x 5-1/2	3
133	Z71576G8	Hex Bolt, 1/2NF x 1-1/2 Gr8	3
134	Z72251	Hex Lock Nut, 1/2NC	4

Hydraulic Valves

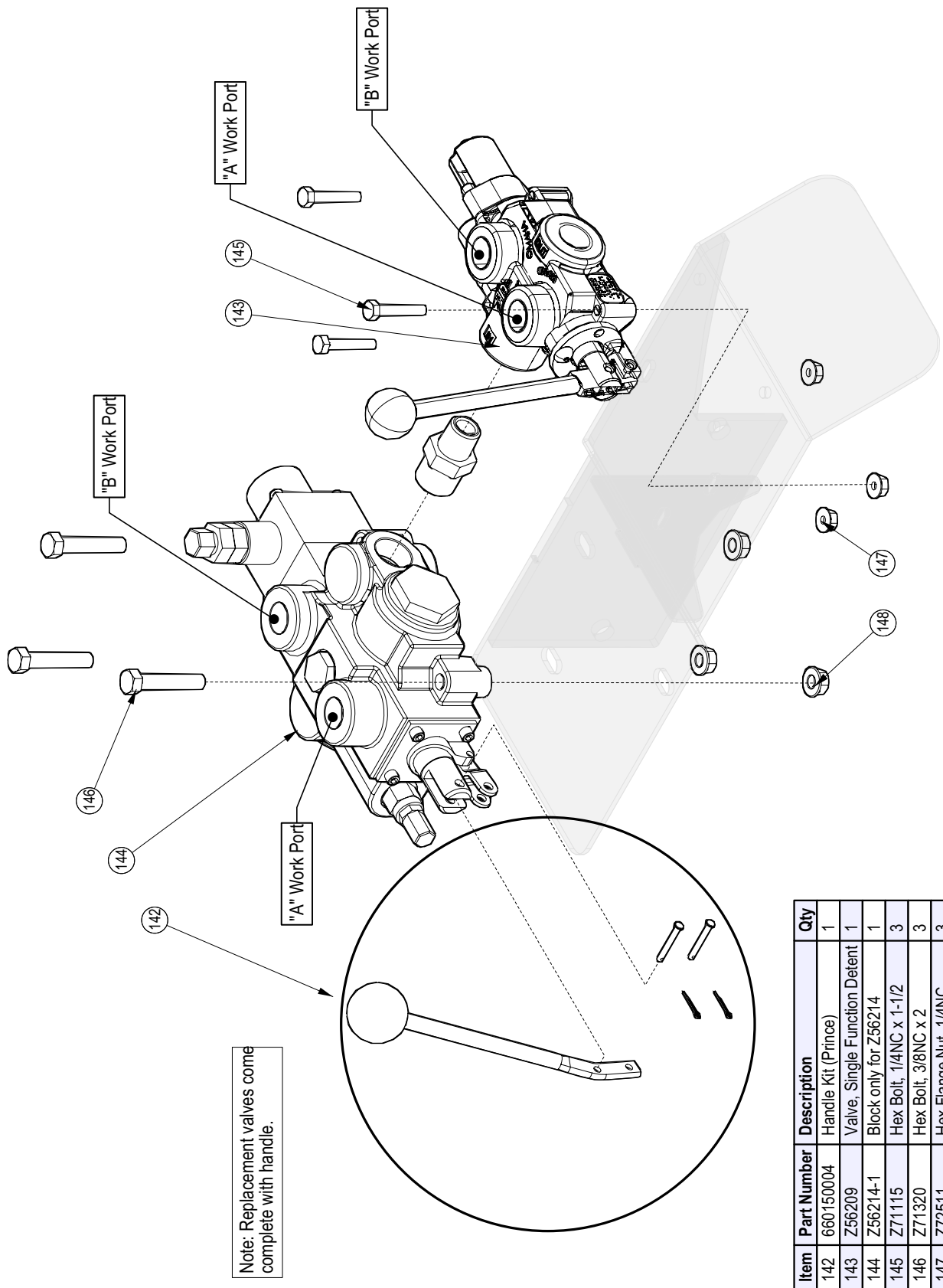

Item	Part Number	Description	Qty
142	660150004	Handle Kit (Prince)	1
143	Z56209	Valve, Single Function Detent	1
144	Z56214-1	Block only for Z56214	1
145	Z71115	Hex Bolt, 1/4NC x 1-1/2	3
146	Z71320	Hex Bolt, 3/8NC x 2	3
147	Z72511	Hex Flange Nut, 1/4NC	3
148	Z72531	Flange Nut 3/8NC	3

Hydraulic Cylinder

151	575-346	4-1/2" Back-Up Ring	1
152	G450-250S	4-1/2" X 2-1/2" GLAND	1
153	P100-450SP	4-1/2" BORE PISTON	1
154	PSC-346	4-1/2" Double Acting Piston Seal	1
155	ST-250	2-1/2" Rod Wiper	1
156	UI8-250-37B	2-1/2" X 2-7/8" X 3/8" U-CUP	1
157	Z51195	Socket Plug MP12	1
158	Z72292G8	Hex Lock Nut, 1-12NF Gr8	1
159	2071C1014	Barrel, 4-1/2"	1

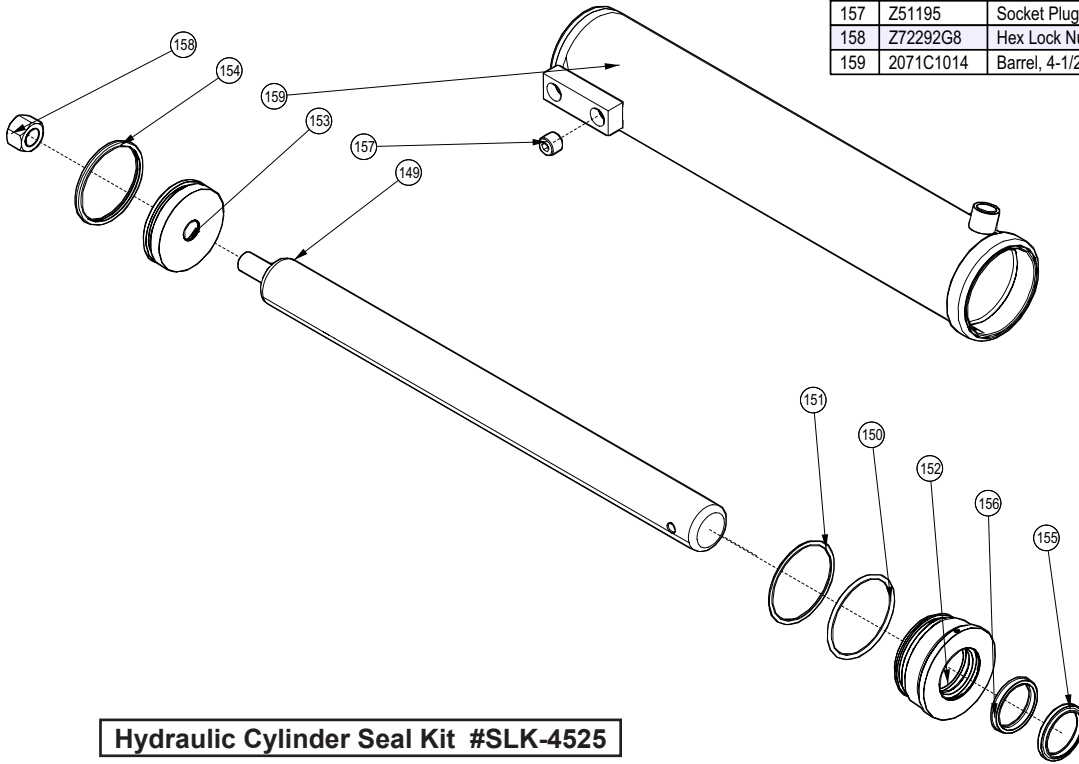

Hydraulic Cylinder Seal Kit #SLK-4525

VIEW SHOWS PROPER SEAL ORIENTATION

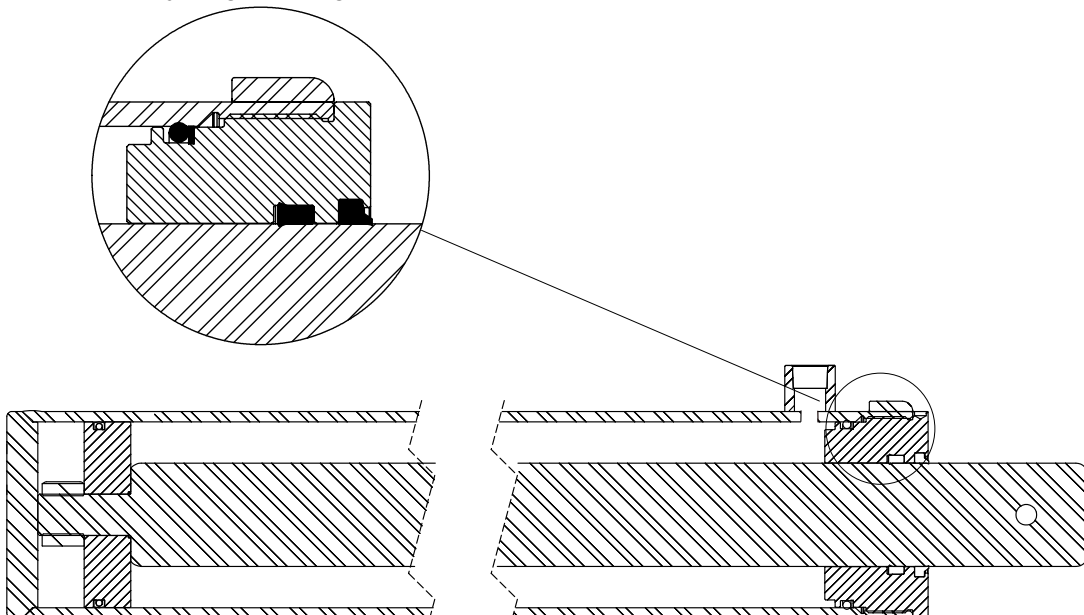

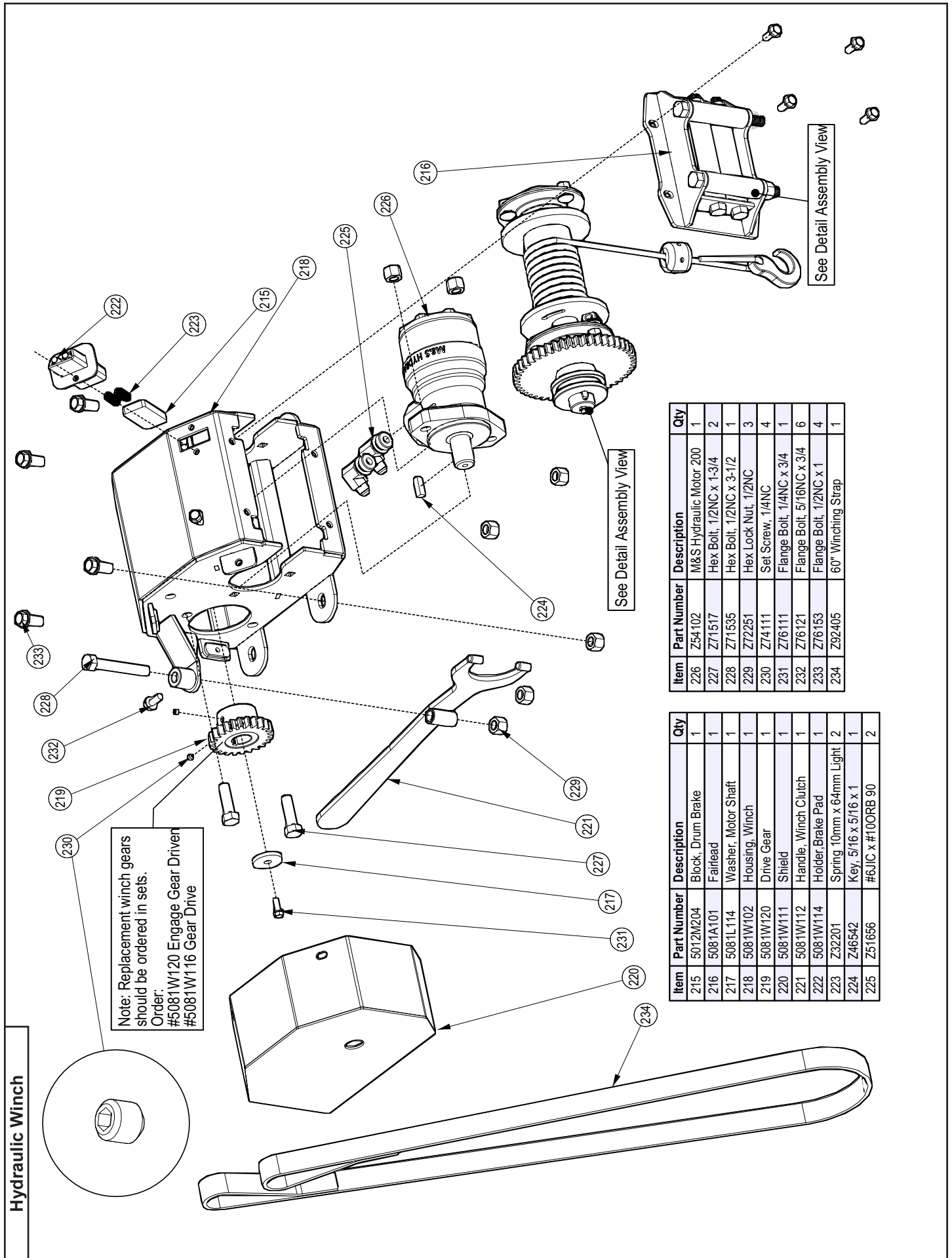

Note: Replacement winch gears should be ordered in sets.
 Order:
 #5081W120 Engage Gear Drive
 #5081W116 Gear Drive

See Detail Assembly View

See Detail Assembly View

Item	Part Number	Description	Qty
226	Z64-102	M&S Hydraulic Motor 200	1
227	Z71517	Hex Bolt, 1/2NC x 1-3/4	2
228	Z71535	Hex Bolt, 1/2NC x 3-1/2	1
229	Z72251	Hex Lock Nut, 1/2NC	3
230	Z74111	Set Screw, 1/4NC	4
231	Z76111	Flange Bolt, 1/4NC x 3/4	1
232	Z76121	Flange Bolt, 5/16NC x 3/4	6
233	Z76153	Flange Bolt, 1/2NC x 1	4
234	Z92405	60" Winching Strap	1

Item	Part Number	Description	Qty
215	5012M204	Block, Drum Brake	1
216	5081A101	Fairlead	1
217	508-L114	Washer, Motor Shaft	1
218	5081W102	Housing, Winch	1
219	5081W120	Drive Gear	1
220	5081W111	Shield	1
221	5081W112	Handle, Winch Clutch	1
222	5081W114	Holder, Brake Pad	1
223	Z32201	Spring 10mm x 64mm Light	2
224	Z46542	Key, 5/16 x 5/16 x 1	1
225	Z51656	#6JIC x #10ORB 90	2

Hydraulic Winch

Winch Drum Detail

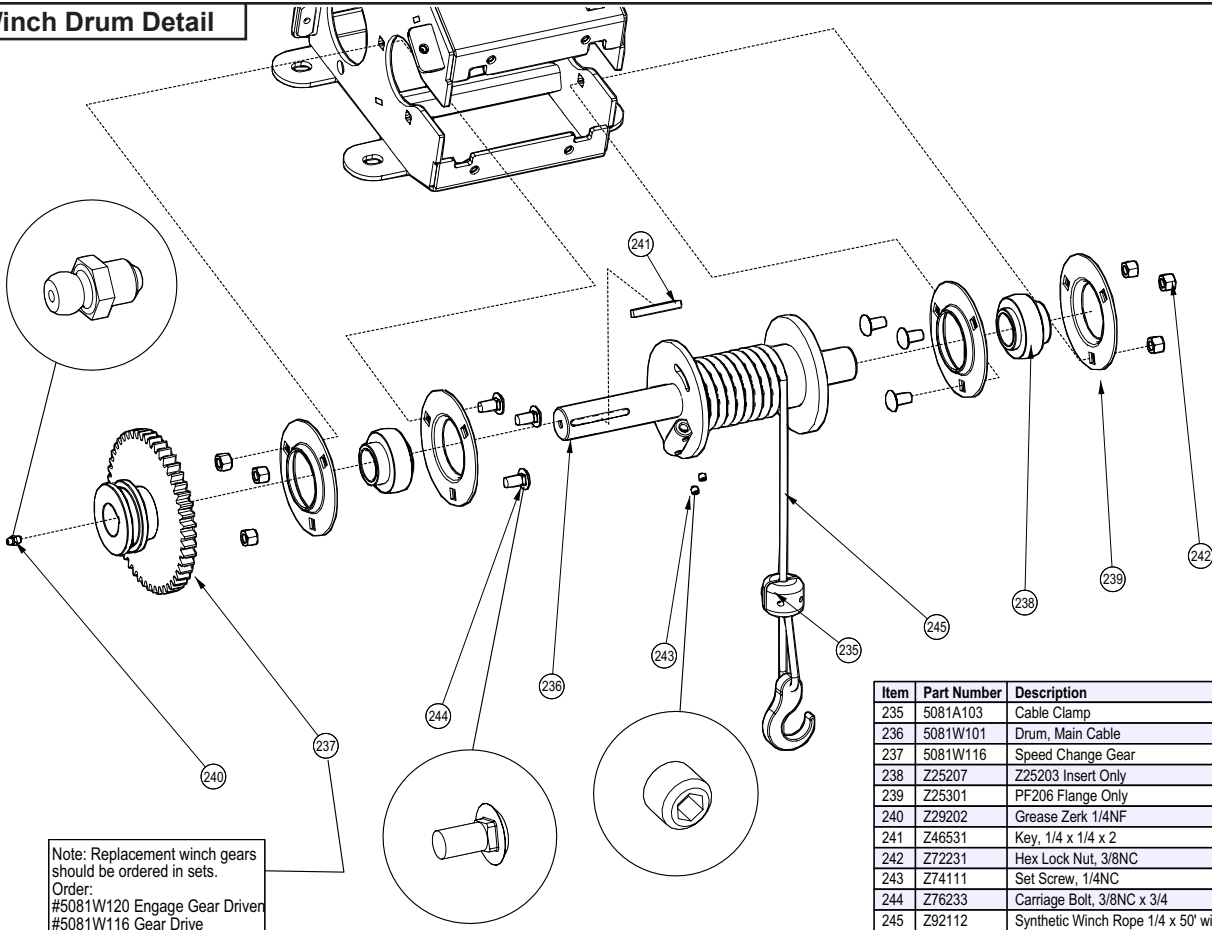

Note: Replacement winch gears should be ordered in sets.
 Order:
 #5081W120 Engage Gear Drive
 #5081W116 Gear Drive

Item	Part Number	Description	Qty
235	5081A103	Cable Clamp	1
236	5081W101	Drum, Main Cable	1
237	5081W116	Speed Change Gear	1
238	Z25207	Z25203 Insert Only	2
239	Z25301	PF206 Flange Only	4
240	Z29202	Grease Zerk 1/4NF	1
241	Z46531	Key, 1/4 x 1/4 x 2	1
242	Z72231	Hex Lock Nut, 3/8NC	6
243	Z74111	Set Screw, 1/4NC	2
244	Z76233	Carriage Bolt, 3/8NC x 3/4	6
245	Z92112	Synthetic Winch Rope 1/4 x 50' with Hook	1

Winch Fairlead Detail

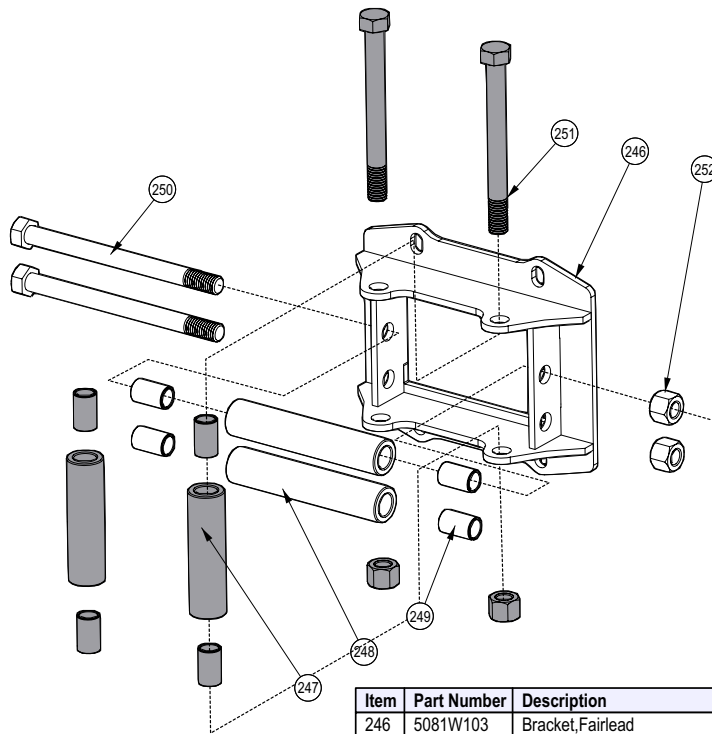

Item	Part Number	Description	Qty
246	5081W103	Bracket, Fairlead	1
247	5081M109	Bushing, Fairlead Side	2
248	5081M111	Bushing, Fairlead Top	2
249	Z27103	Fiberglide Bearing 1/2" x 1"	8
250	Z71566	Hex Bolt, 1/2NC x 6-1/4, 5-1/4 Shank	2
251	Z71567	Hex Bolt, 1/2NC x 5, 4" Shank	2
252	Z72251	Hex Lock Nut, 1/2NC	4

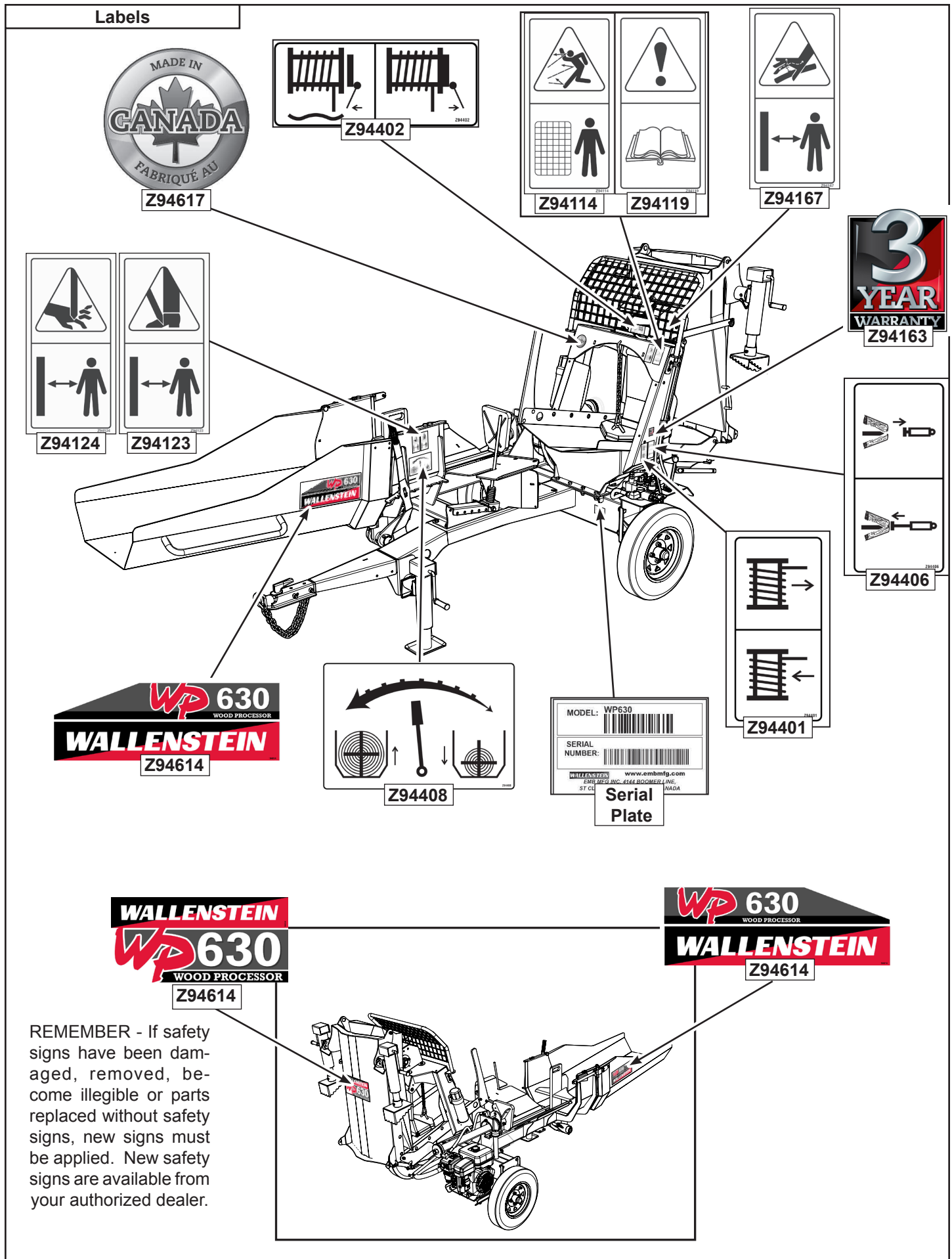

Labels



Z94617

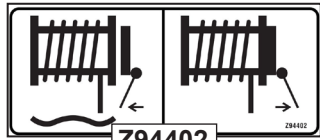

Z94402



Z94114

Z94119



Z94167



Z94163



Z94124

Z94123



Z94614

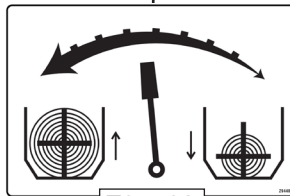

Z94408



Serial Plate

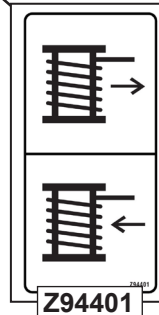

Z94401

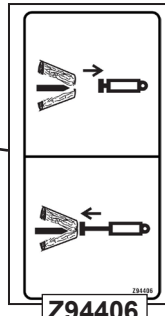

Z94406



Z94614



Z94614

REMEMBER - If safety signs have been damaged, removed, become illegible or parts replaced without safety signs, new signs must be applied. New safety signs are available from your authorized dealer.

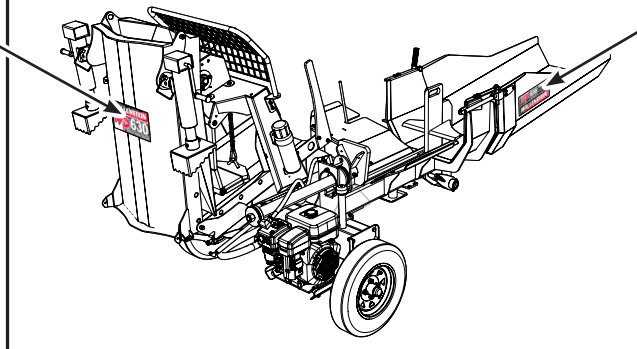

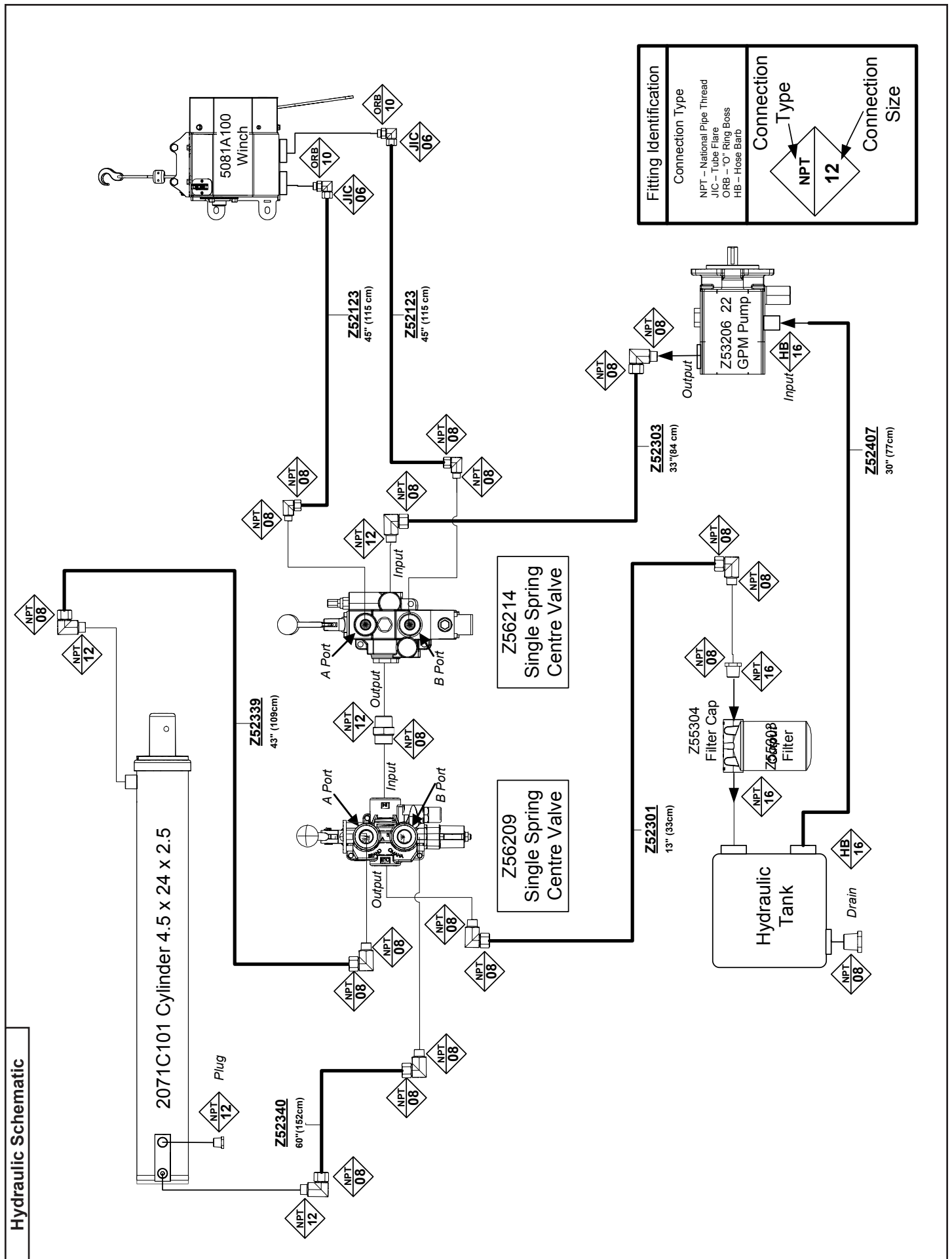

Accessories

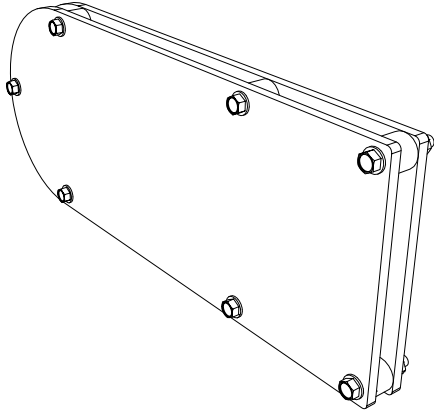

#2089A570 NYLON CHAINSAW HOLSTER

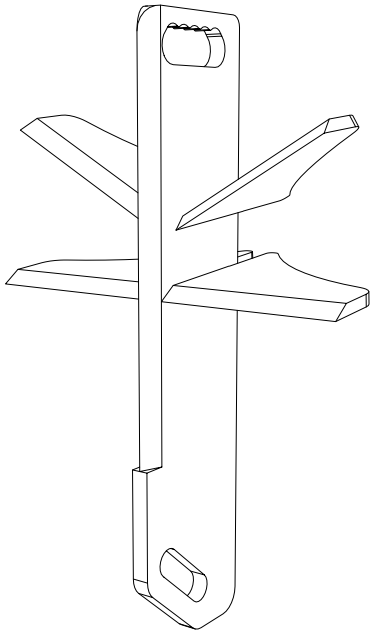

#2089W571 6-WAY WEDGE

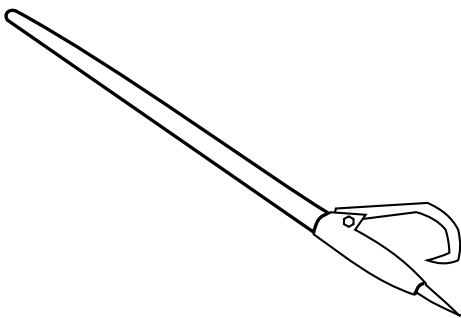

#299001 48" LOG PEAVEY

Manual

WALLENSTEIN
by EMB MFG. INC.

EMB Manufacturing Inc.
4144 Bommer Line - St. Clements, On. N0B 2M0 - Canada
Ph: (519) 829-9292 Fax: (519) 824-1146
www.embmfg.com

WP830
WP860

**Wood Processor
MODEL WP630, WP830 & WP860
OPERATOR'S MANUAL**

PRINTED IN CANADA
Rev: 306112

PART NUMBER: 297062

297062

Available as a download at
www.embmfg.com

