

PARTS MANUAL

Serial Number 5851 & up

FX85 / FX85R **PTO-driven Log Skidding Winch**

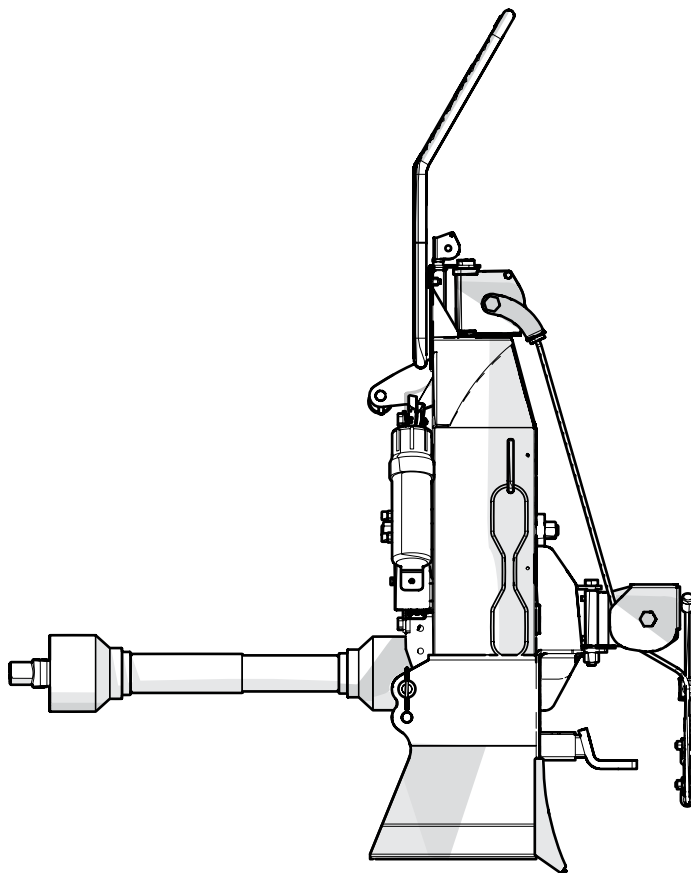

Foreword

This Wallenstein parts manual is prepared to assist customers in ordering quality OEM replacement parts.

Regular maintenance combined with replacing old, worn or broken parts with the correct OEM parts is essential in prolonging the life of your Wallenstein product. Refer to this manual to identify replacement parts.

To order parts, contact your Wallenstein dealer or distributor. Have the product model and serial number handy.

If your dealer is no longer available, please go to WallensteinEquipment.com. At the bottom of the page, select Dealer Locator.

All information contained in this parts manual is current as per the revision date at the bottom of the page. Wallenstein reserves the right to change product specifications at any time without notice.

If your product specifications differ from those contained in this manual, contact Wallenstein for current information.

Reproduction of information in this parts manual is prohibited without prior written permission from Wallenstein Equipment Inc.

Wallenstein Equipment Inc. • © 2023

WARNING!

For safety, operation, and maintenance information, see the Operator's Manual.

Maintenance should be performed by trained personnel only.

Serial Number Location

Always provide the model and serial number of your Wallenstein product when ordering parts or requesting service or other information. The serial number is on the product information plate as shown below.

Record your product information here for future reference.

Model _____

Serial Number _____

Models Covered in this manual

FX85 Log Skidding Winch

FX85R Log Skidding Winch with Remote Control

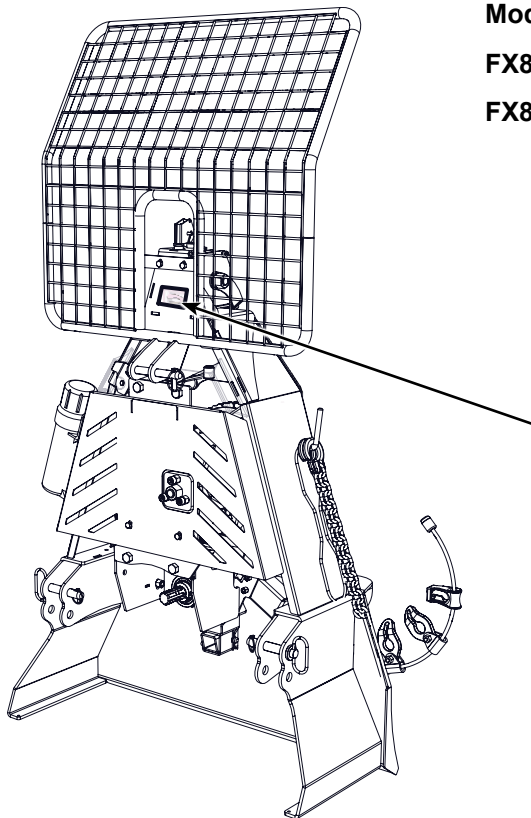

**Model and Serial
Number Location**

www.wallensteinequipment.com

Contents

Main Parts	4
Drum Frame Assembly	5
Cable Drum Assembly	6
Clutch Assembly	7
Engagement Lever Assembly	8
Chain Tightener Assembly	8
Top Cable Pulley Assembly	9
Snatch Block Assembly	10
Clutch Pulley	11
PTO Shaft	12
Cable Install	13
Brake and Clutch Rope Routing	14
Cylinder Assembly – FX85R	14
Cylinder / Clutch Plate Assembly – FX85R; S/N 5851–585880	15
Cylinder / Clutch Plate Assembly – FX85R; S/N 585881 & Up	15
Remote Control Components – FX85R; S/N 5851–585880	16-A
Remote Control Components – FX85R; S/N 585881 & Up	16-B
Hydraulic Plumbing Diagram– FX85R	17
Decal Layout	18
Accessories	20
Common Bolt Torque Values	21
Hydraulic Fitting Torque Values	22

Main Parts

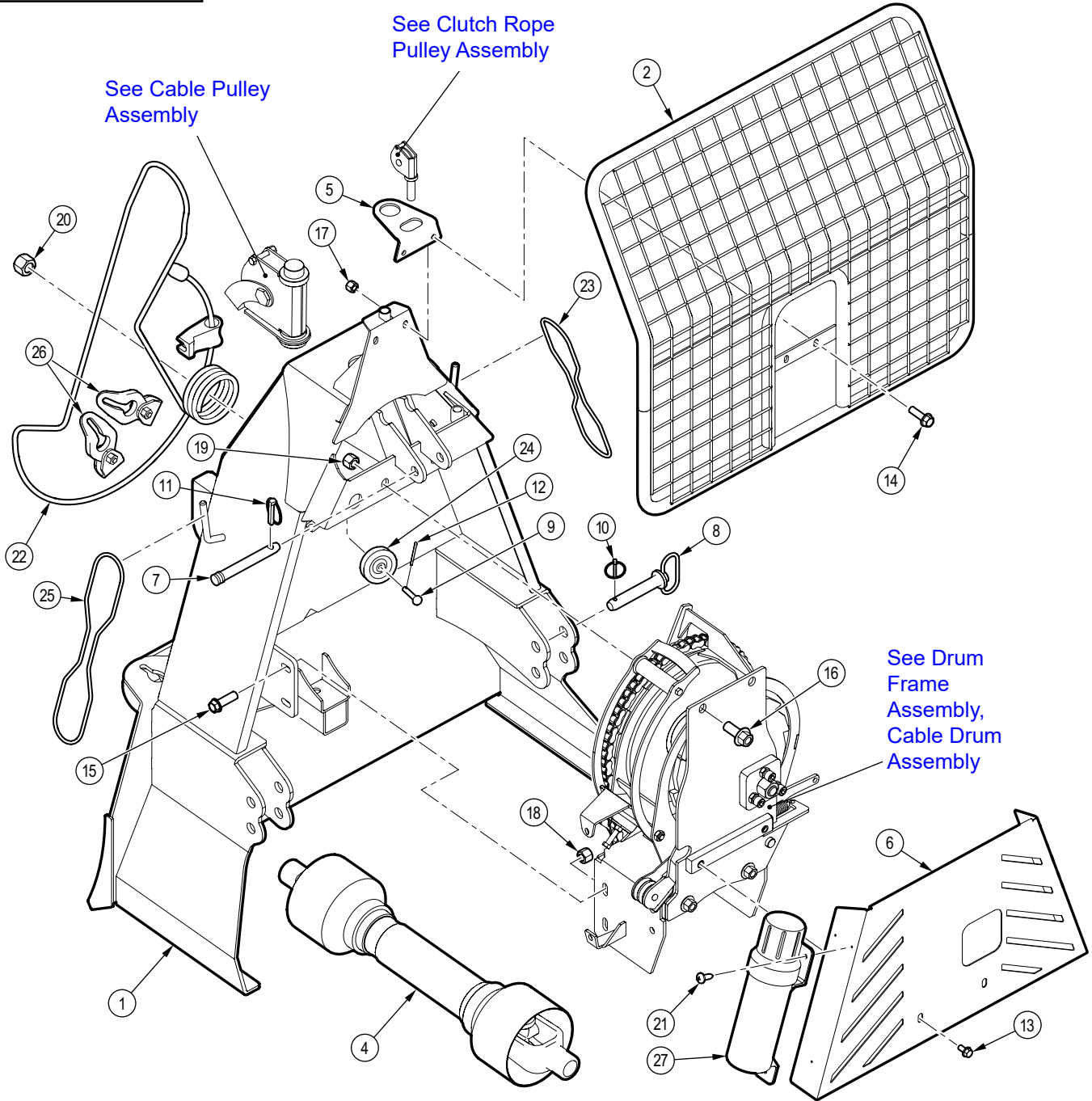

Item No.	Part No.	Description	Qty
1	5011W020	Main Frame	1
2	5011W022	Safety Screen	1
4	Z44402	#4 Global PTO Shaft M8 Shear	1
5	5011L636	Bracket, Top Pulley Capture	1
6	5011L686	Lower Protective Shield	1
7	Z11123	Toplink Pin, 3/4" x 4-3/4"	1
8	Z11251	Hitch Pin, 7/8" x 4-1/4"	2
9	Z11311	Clevis Pin, 1/4" x 1-1/8"	2
10	Z12110	Lynch Pin, 3/16"	2
11	Z12140	Lynch Pin, 7/16"	1
12	Z12311	Cotter Pin, 1/8" x 1"	2
13	Z76133	Hex Bolt, 3/8NC x 3/4"	2
14	Z76137	Hex Bolt, 3/8NC x 1-1/4"	2

Item No.	Part No.	Description	Qty
15	Z76156	Hex Bolt, 1/2NC x 1-1/2"	2
16	Z76161	Hex Bolt, 5/8NC x 1-1/2"	2
17	Z72231	Hex Lock Nut, 3/8NC	2
18	Z72251	Hex Lock Nut, 1/2NC	2
19	Z72261	Hex Lock Nut, 5/8NC	2
20	Z72281	Hex Lock Nut, 7/8NC	1
21	Z76721	Self-tapping Screw, 1/4 x 3/4"	3
22	Z92119-1	Winch Cable, 3/8" x 165ft, Forged End	1
23	Z92201	Green Nylon Rope 1/4" x 9 1/2 ft	1
24	Z92203	1/4 Groove Pulley 2 Diam.	2
25	Z92205	White Nylon Rope 1/4" x 18 ft	1
26	Z92301	Keyhole Slider	2
27	Z96503	Manual Tube 3-1/2 Short	1

Drum Frame Assembly

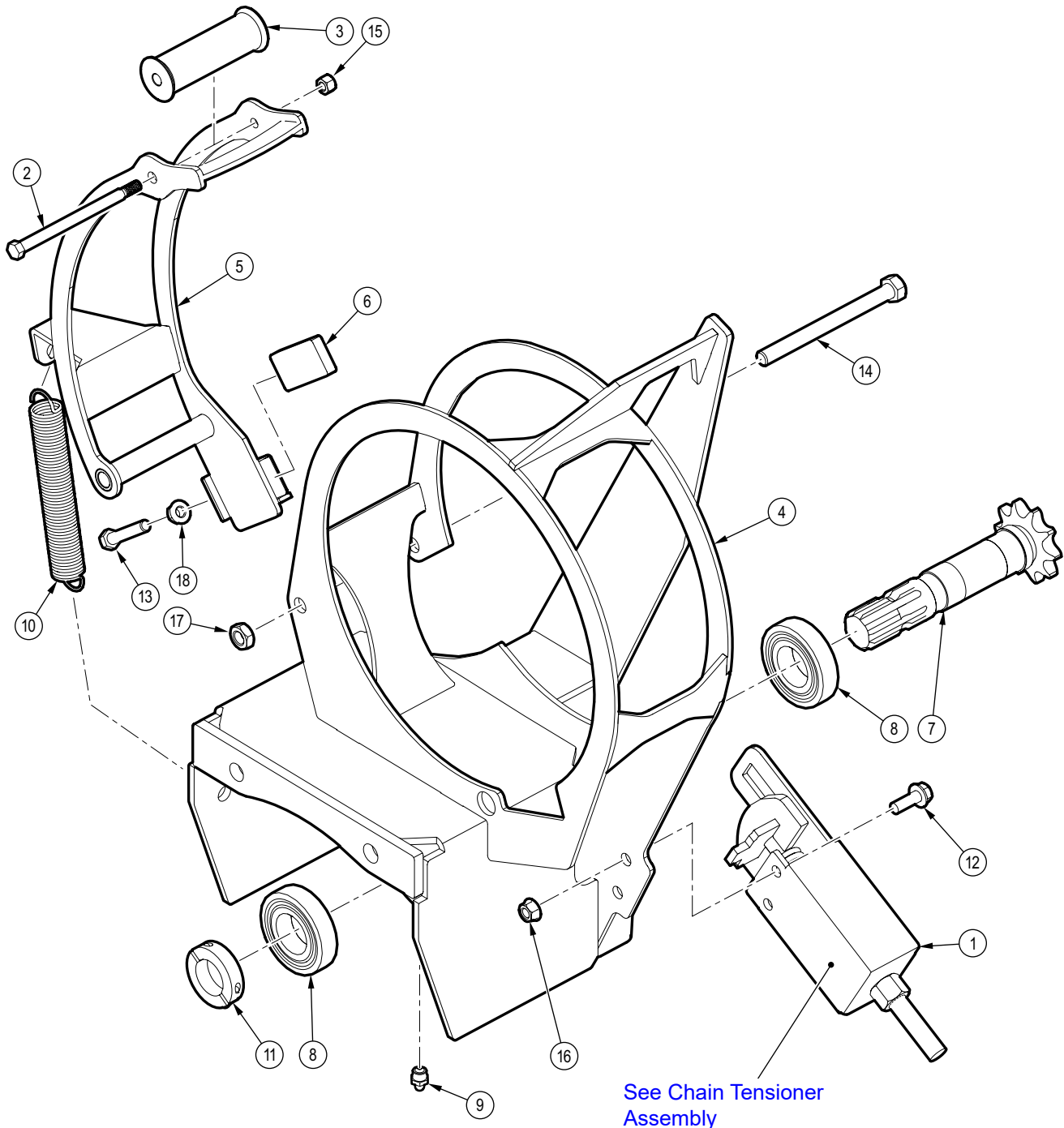

Item No.	Part No.	Description	Qty
1	5011A520	Assembly, Chain Tightener	1
2	5011M824	Pin, Cable Roller	1
3	5011S155	Roller, Brake Arm	1
4	5011W002	Frame, Main Clutch	1
5	5011W007	Arm Frame, Anti-Tangle	1
6	5012M204	Block, Drum Brake	1
7	5012W208	PTO Spline Shaft w/ Sprocket	1
8	Z21202	Ball Bearing 6207-2RS	2
9	Z29201	Grease Fitting, 1/8NPT	1

Item No.	Part No.	Description	Qty
10	Z31403	Ext Spring, 27mm OD x 178mm x 0.105"	1
11	Z46311	Clamp-on Shaft Collar	1
12	Z71307	Hex Bolt, 3/8NC x 3/4"	2
13	Z71320	Hex Bolt, 3/8NC x 2"	1
14	Z71555	Hex Bolt, 1/2NC x 5-1/2"	1
15	Z72221	Hex Lock Nut, 5/16NC	1
16	Z72231	Hex Lock Nut, 3/8NC	2
17	Z72351	Jam Nut, 1/2NC	1
18	Z72531	Serrated Flange Locknut, 3/8NC	1

Cable Drum Assembly

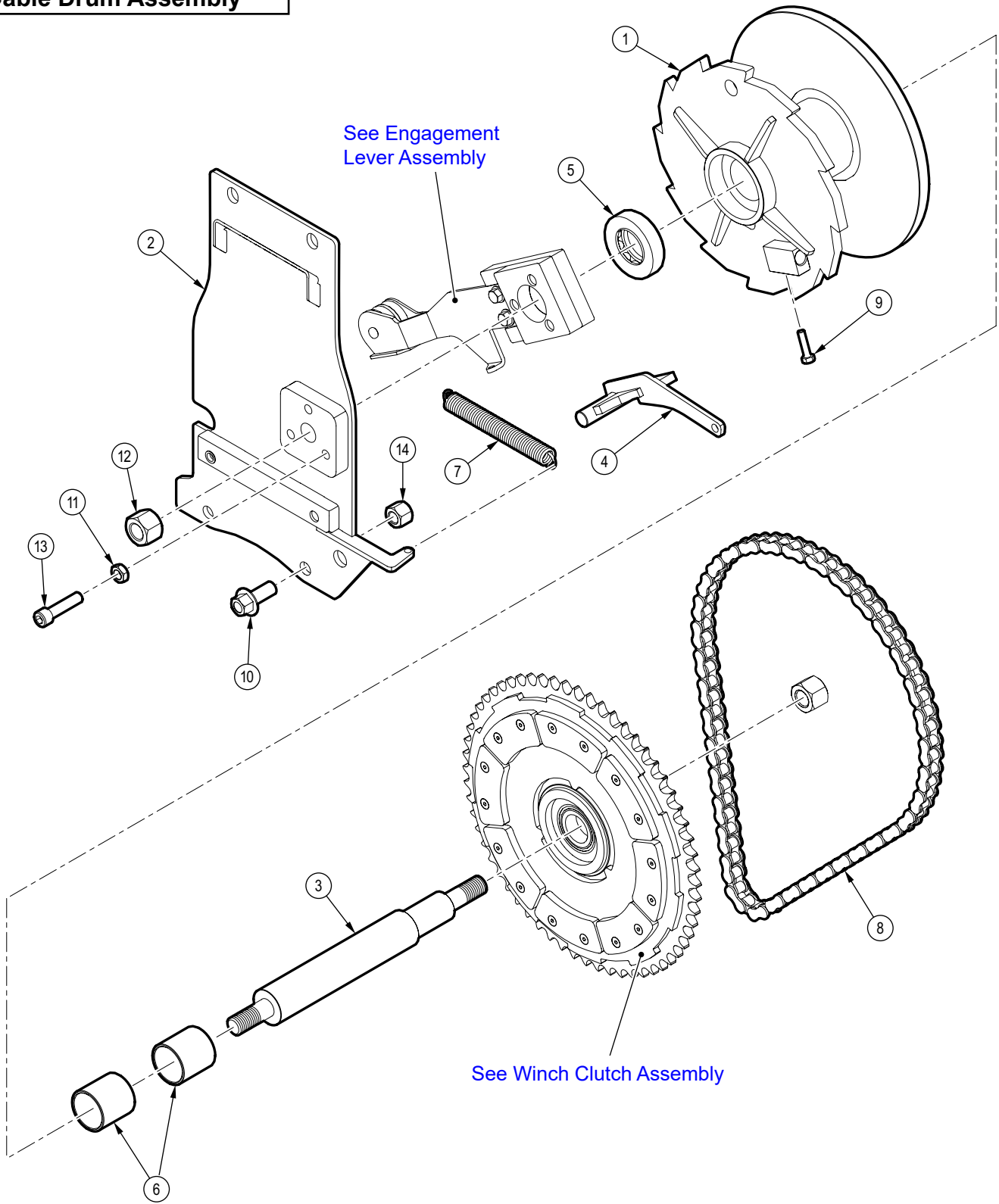

Item No.	Part No.	Description	Qty
1	5011W006	FX65 Cable Drum	1
2	5011W016	Clutch Back Plate	1
3	5012M214	Main Drum Shaft	1
4	5012W206	Lock Dog	1
5	Z22101	1-3/4 Bore Shielded Thrust Bearing	1
6	Z27101	Fiberglide Bearing 1-3/4" ID x 2" long x 1/8" wall	2
7	Z31405	Ext Spring, 7/8" OD x 7" x 0.125"	1

Item No.	Part No.	Description	Qty
8	Z42152	Roller Chain, #60x74 links	1
9	Z71212	Hex Bolt, 5/16NC x 1-1/4"	1
10	Z76161	Flange Bolt, 5/8NC x 1-1/2"	2
11	Z72352	Jam Nut, 1/2NF	3
12	Z72281	Hex Lock Nut, 7/8NC	1
13	Z75151	SHCS, 1/2NF x 2"	3
14	Z72261	Hex Lock Nut, 5/8NC	2

Clutch Assembly

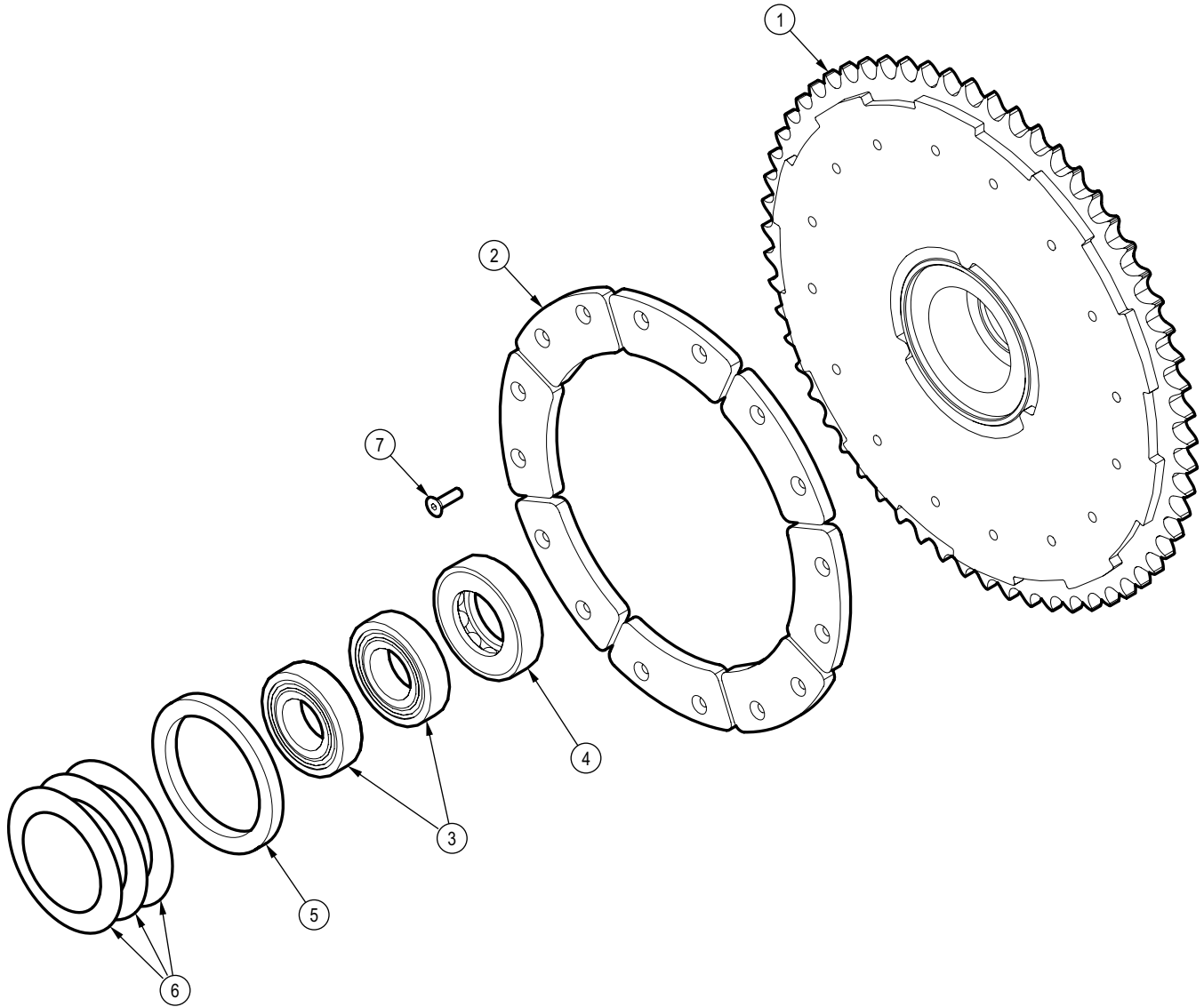

Item No.	Part No.	Description	Qty
1	5012W209	60 Tooth Sprocket	1
2	5011S152	Pad, Sprocket	8
3	Z21202	Ball Bearing 6207-2RS	2
4	Z22101	1-3/4 Bore Shielded Thrust Bearing	1
5	5012M228	Nylon Bearing Washer	1
6	Z34101	Cup Spring, 2-3/4" ID x 4" OD x 1mm	3
7	Z75211	FHCS, 1/4NC x 7/8"	16

Engagement Lever Assembly

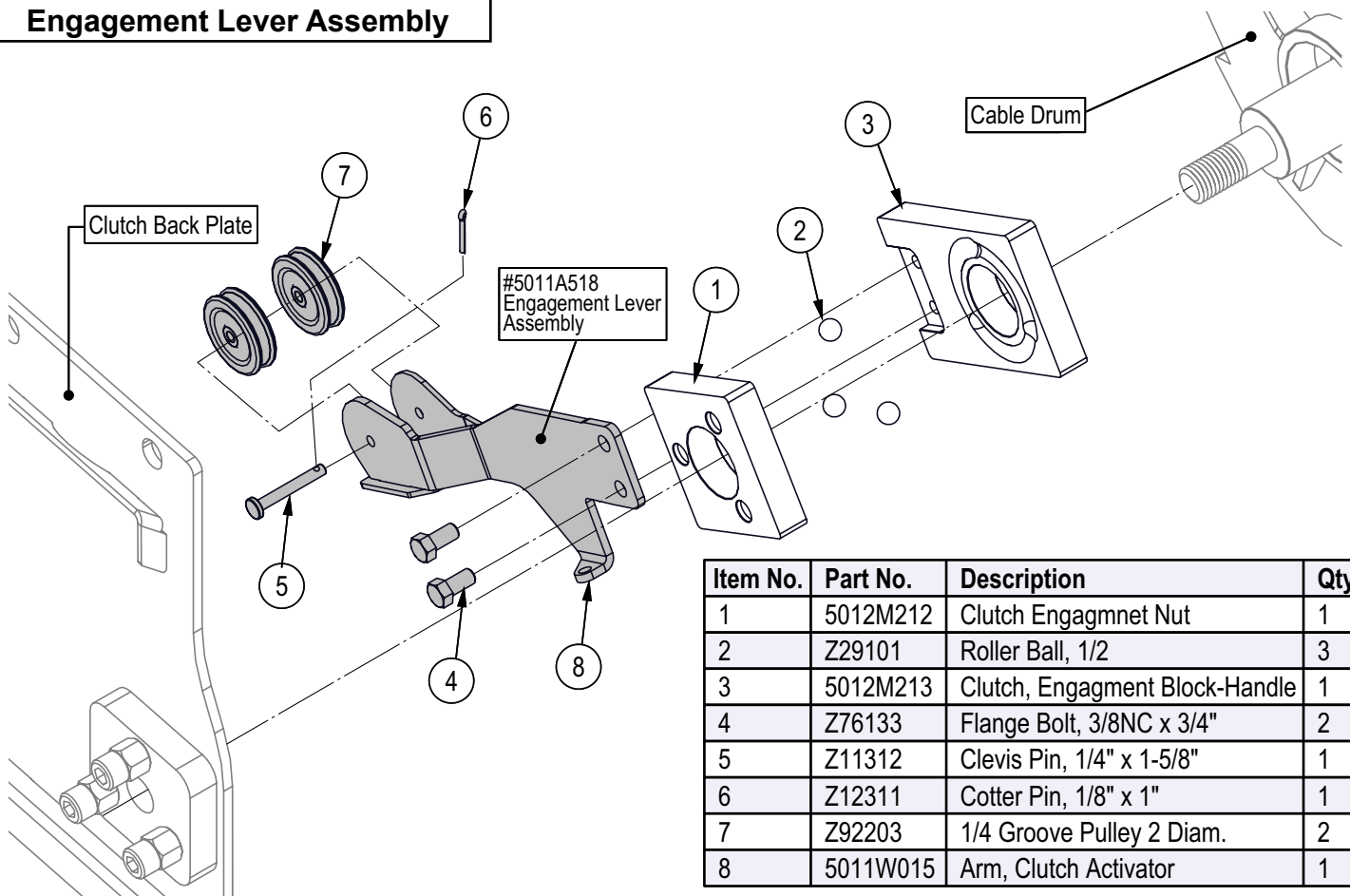

Item No.	Part No.	Description	Qty
1	5012M212	Clutch Engagmnet Nut	1
2	Z29101	Roller Ball, 1/2	3
3	5012M213	Clutch, Engagment Block-Handle	1
4	Z76133	Flange Bolt, 3/8NC x 3/4"	2
5	Z11312	Clevis Pin, 1/4" x 1-5/8"	1
6	Z12311	Cotter Pin, 1/8" x 1"	1
7	Z92203	1/4 Groove Pulley 2 Diam.	2
8	5011W015	Arm, Clutch Activator	1

Chain Tightener Assembly

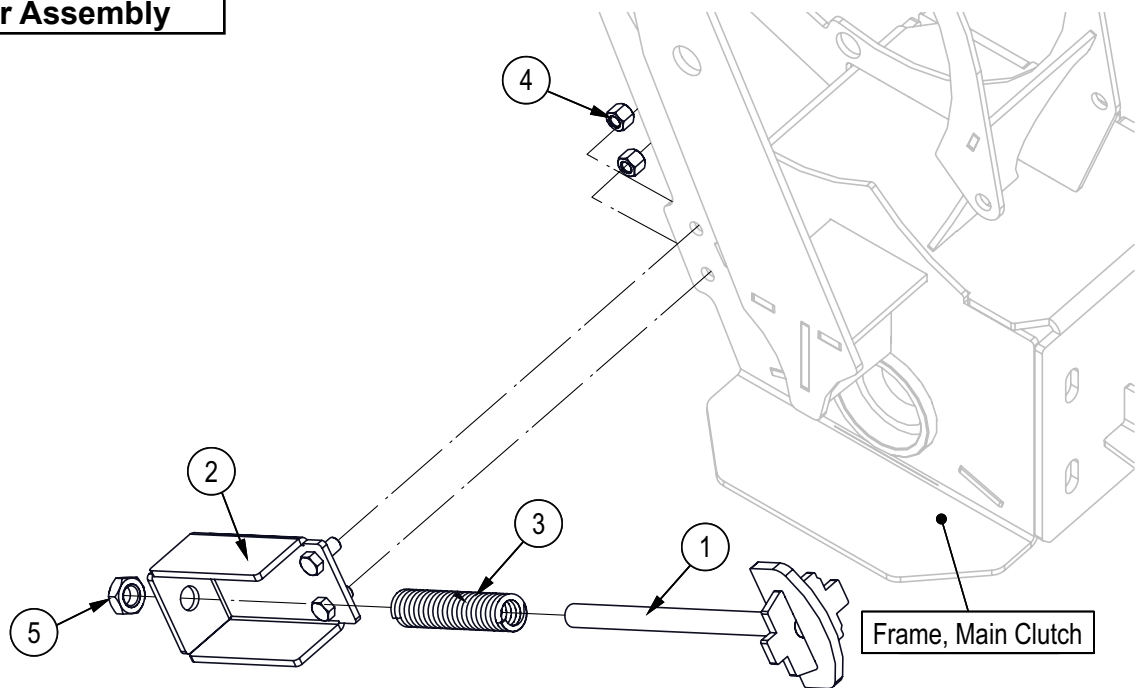

Item No.	Description	Description	Qty
1	5012W205	Chain Tightener Plunger	1
2	5011L631	Base, Auto Chain Tightener	1
3	Z32401	Comp Spring, 1" OD x 7" x 0.162"	1
4	Z72531	Serrated Flange Locknut, 3/8NC	2
5	Z72261	Hex Lock Nut, 5/8NC	1

Top Cable Pulley and Clutch Pulley

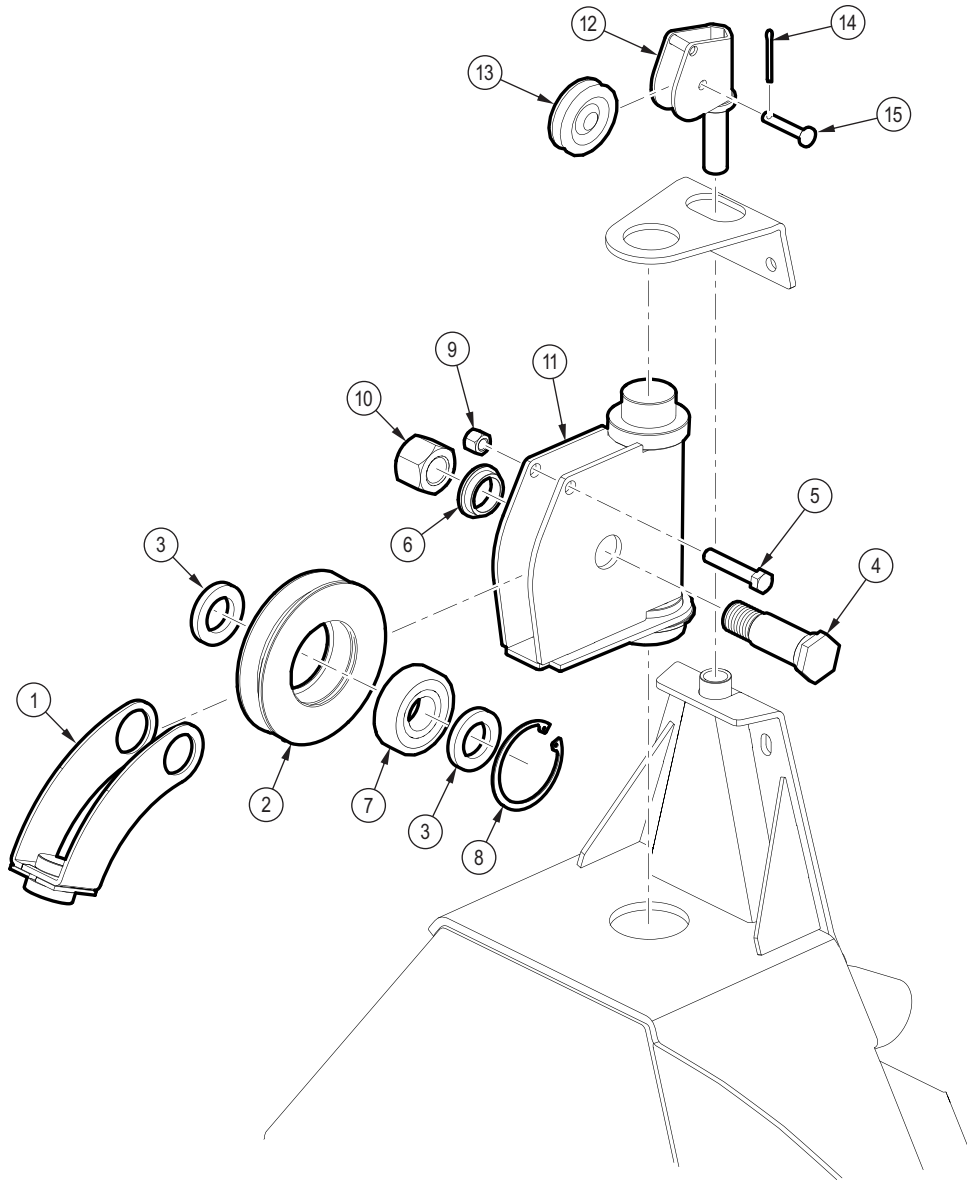

Item No.	Part No.	Description	Qty
1	5011W008	Cable Guide	1
2	5011M816	Cable Pulley	1
3	5011L647	Washer, Pulley Spacer - Narrow	2
4	5011M814	Top Pulley Pin	1
5	Z71320	Hex Bolt, 3/8NC x 2"	1
6	5012M222	Cable Guide Swing Bushing	1
7	Z21201	Ball Bearing 6305 2RS	1
8	Z46101	Internal Retaining Ring 2-7/16	1

Item No.	Part No.	Description	Qty
9	Z72231	Hex Lock Nut, 3/8NC	1
10	Z72281	Hex Lock Nut, 7/8NC	1
11	5011W011	Frame, Top Pulley	1
12	5012W215	Clutch Rope Pulley Housing	1
13	Z92203	1/4 Groove Pulley 2 Diam.	1
14	Z12311	Cotter Pin, 1/8" x 1"	1
15	Z11311	Clevis Pin, 1/4" x 1-1/8"	1

Snatch Block Assembly

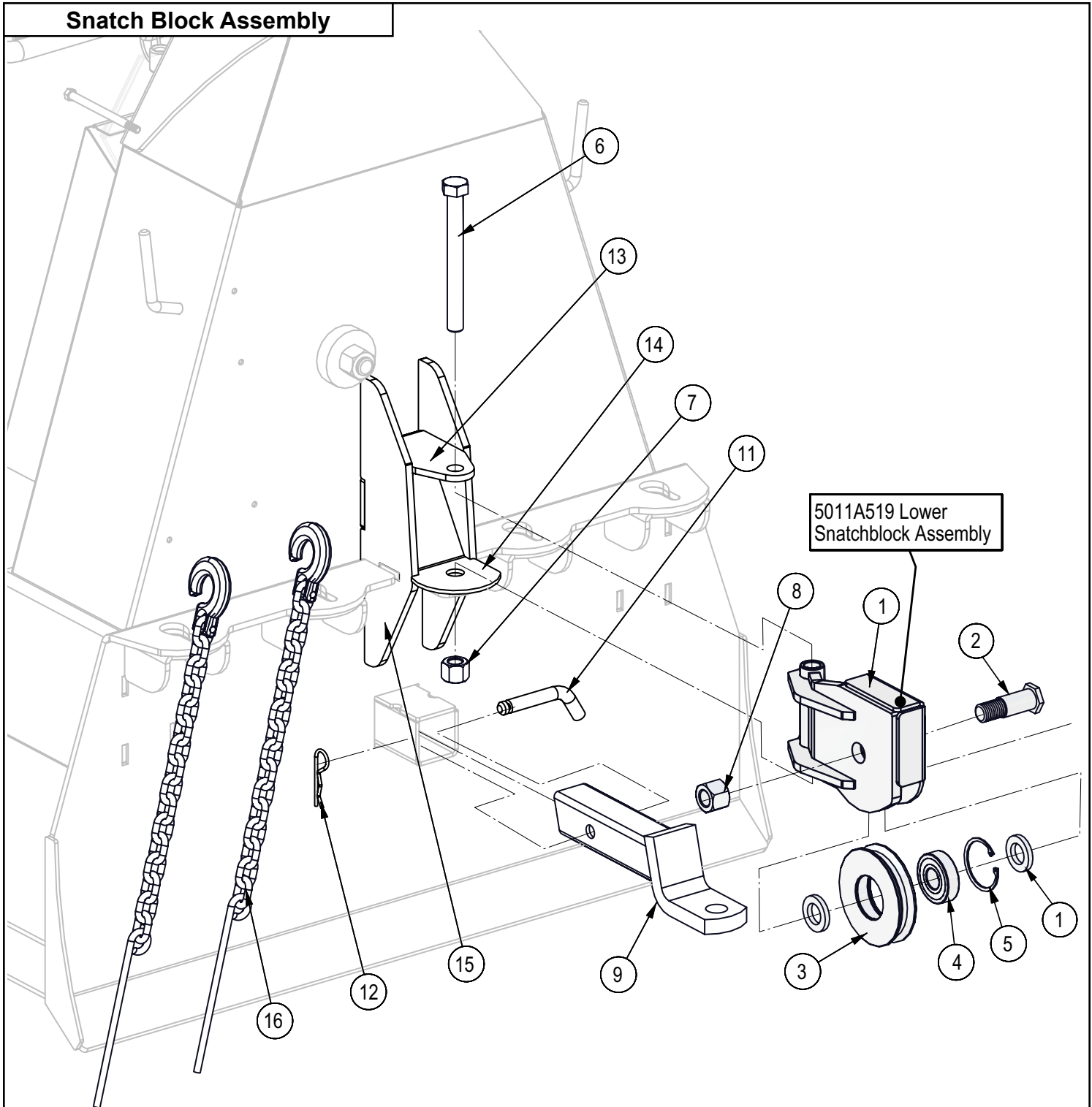

Item No.	Part No.	Description	Qty
1	5011L647	Washer, Pulley Spacer - Narrow	2
2	5011M815	Snatch Block, Pulley Pin	1
3	5011M816	Cable Pulley	1
4	Z21201	Ball Bearing 6305 2RS	1
5	Z46101	Internal Retaining Ring 2-7/16	1
6	Z71770	Hex Bolt, 3/4NC x 7"	1
7	Z72271	Hex Lock Nut, 3/4NC	1
8	Z72281	Hex Lock Nut, 7/8NC	1

Item No.	Part No.	Description	Qty
9	Z91641-1	Ball mount for Z91641	1
10	5011W012	Frame, Snatchblock	1
11	Z91641-2	Pin for Z91641	1
12	Z91641-3	Clip for Z91641	1
13	5011L640	Plate, Lower Pulley Mount	1
14	5011L671	Plate, Cable Lock	1
15	5011L688	Plate, Lower Pulley	2
16	Z92318	Choker Chain, 5/16" x 90"	2

Clutch Pulley

Item No.	Description	Description	Qty
1	5012A207	Clutch Rope Pulley	1
2	5012W215	Clutch Rope Pulley Housing	1
3	Z11311	Clevis Pin, 1/4" x 1-1/8"	1
4	Z12311	Cotter Pin, 1/8" x 1"	1
5	Z92203	1/4 Groove Pulley 2 Diam.	1

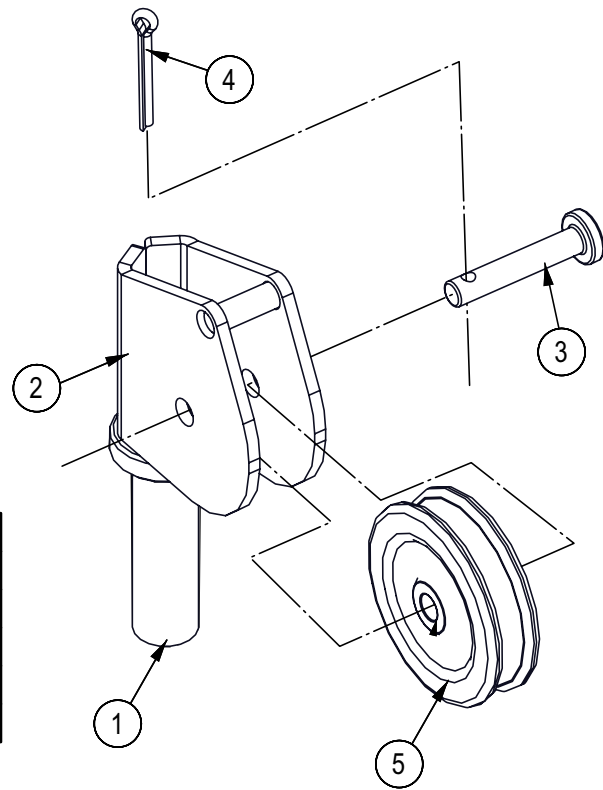

PTO Shaft

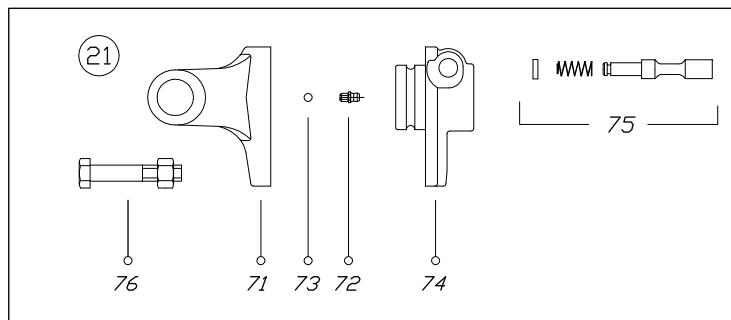
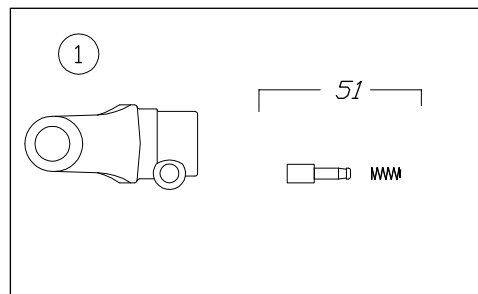
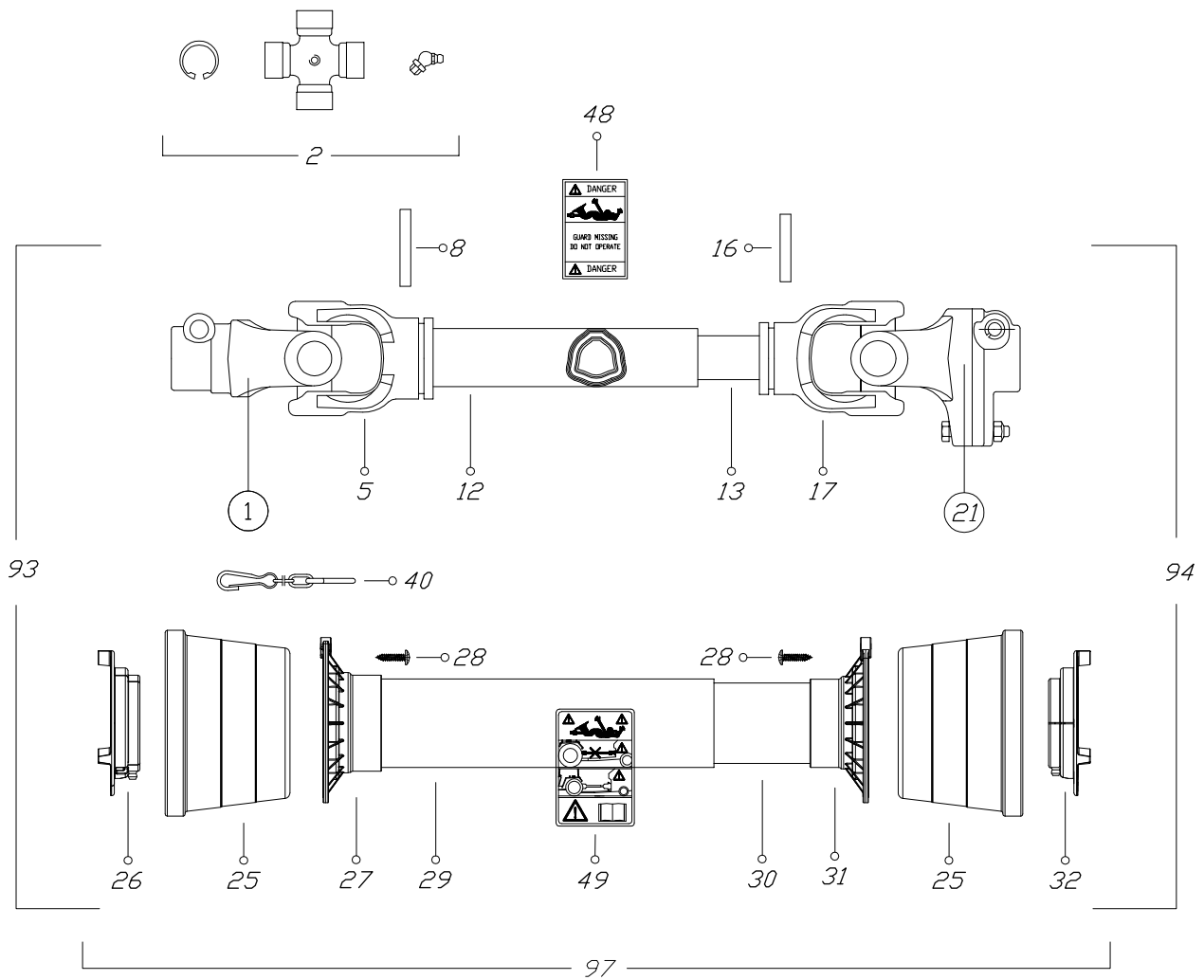

PTO Shaft – P/N Z44402

Item.	Description	Qty.	Part Number
1	YOKE	1	0800403
2	CROSS JOURNAL ASS.	2	08204
5	OUTER TUBE YOKE	1	08004021
8	FLEXIBLE PIN	1	098700860
12	CM. 100 CARDAN TUBE(*)	1	09881433100
13	CM. 100 CARDAN TUBE(*)	1	09881364100
16	FLEXIBLE PIN	1	098700855
17	INNER TUBE YOKE	1	08004011
21	SHEAR BOLT YOKE	1	08805A604633
25	CONE SHIELD BELL 03-04	2	021904C001
26	OUTER BEARING 03-04	1	025504C001
27	OUTER BASE CONE 03-04	1	025404C001
28	SCREW	6	0998052242
29	OUTER SAFETY TUBE	1	0988966NB4061
30	INNER SAFETY TUBE	1	0988961NB4061

Item.	Description	Qty.	Part Number
31	INNER BASE CONE 03-04	1	025404C002
32	INNER BEARING 03-04	1	025504C002
40	CHAIN	1	0252000001
48	LABEL DANGER OUTER DRIVE TUBE	1	09872006
49	EXTERNAL SHIELD LABEL	1	09872003
51	COMPLETE PUSH BUTTTON	1	0986014047
71	YOKE FOR LB4	1	08896904
72	GREASE NIPPLE	1	0984010150
73	STEEL BALL	23	098680104
74	HUB	1	088964
75	PUSH PIN SET	1	0986014075
76	SHEARBOLT AND NUT M8 x 1.25 x 45 10.9	1	Z44902 (Package of 5)
93	OUTER HALF SHAFT	1	B4N061US2
94	INNER HALF SHAFT	1	B4N061US1098
97	SAFETY GUARD	1	083US04061

Cable Install

- Feed cable through the eye of cable guide and over the pulley down into drum.
- Cable must be routed under brake roller on drum band coiler.
- Insert cable into hole in drum and tighten clamp.

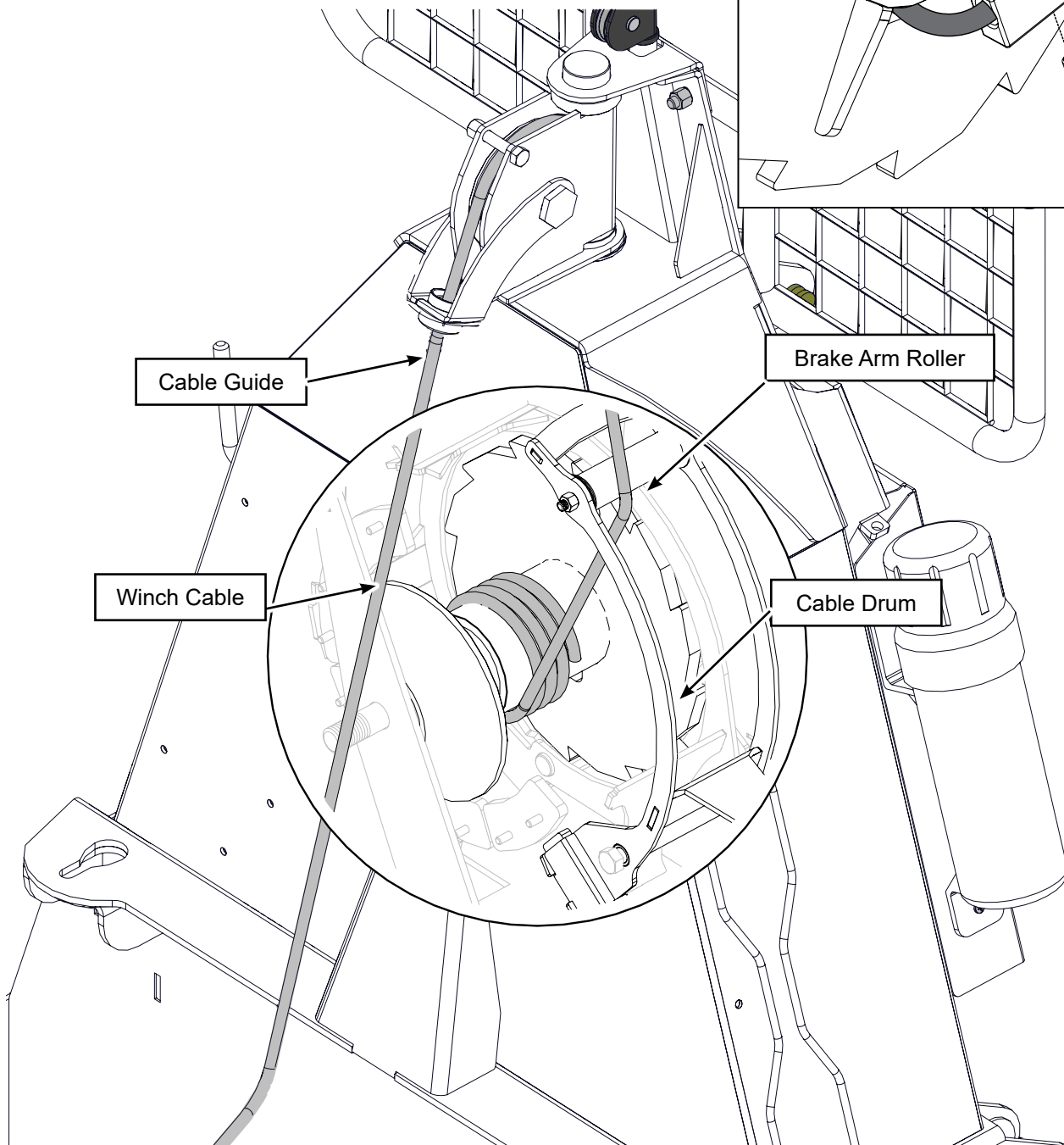
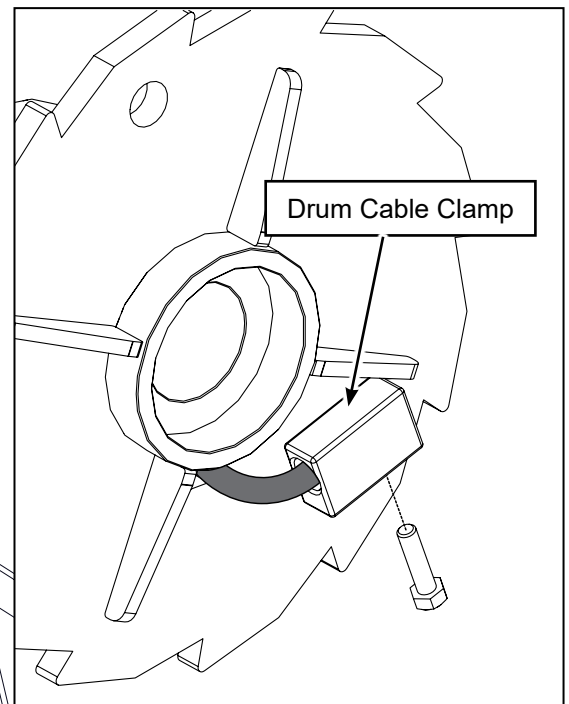

Brake and Clutch Rope Routing

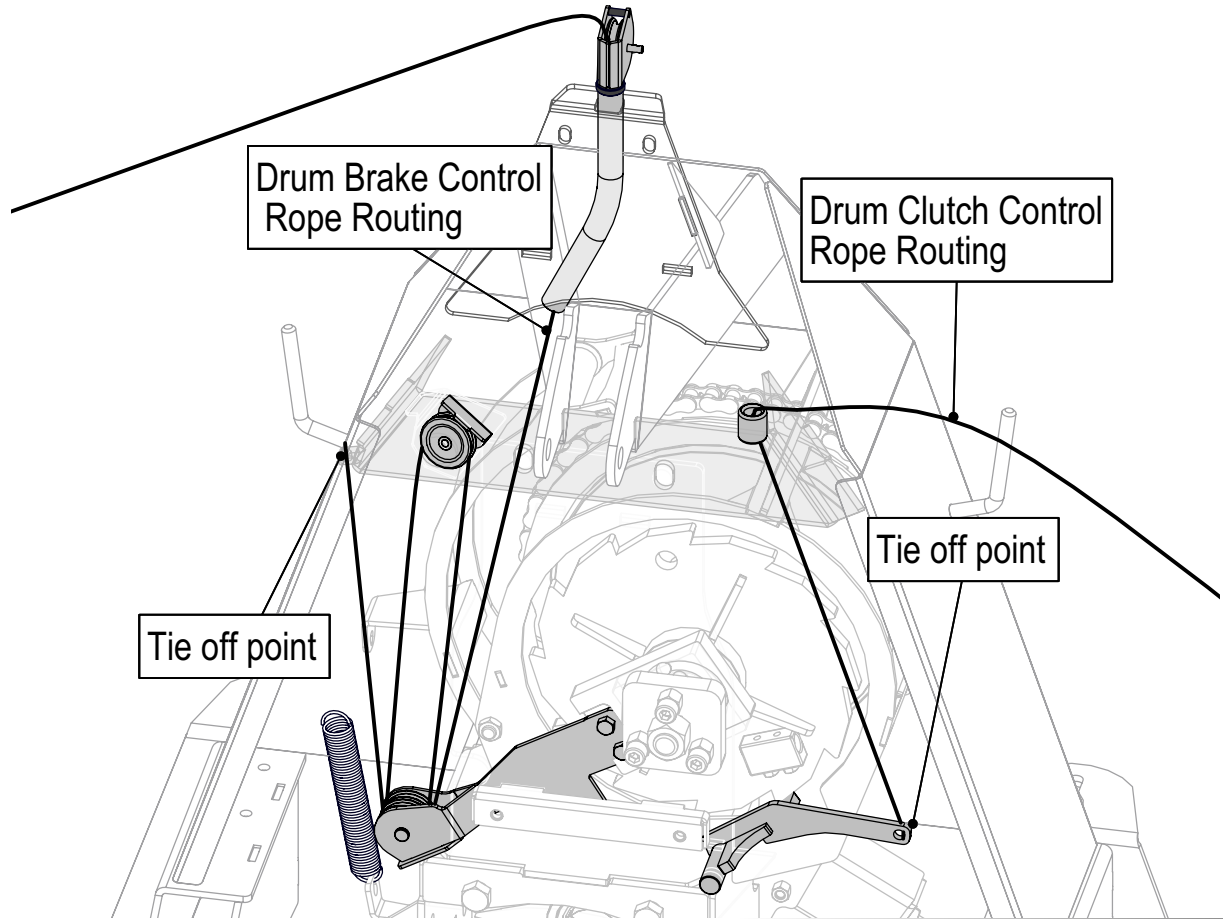

Cylinder Assembly – FX85R

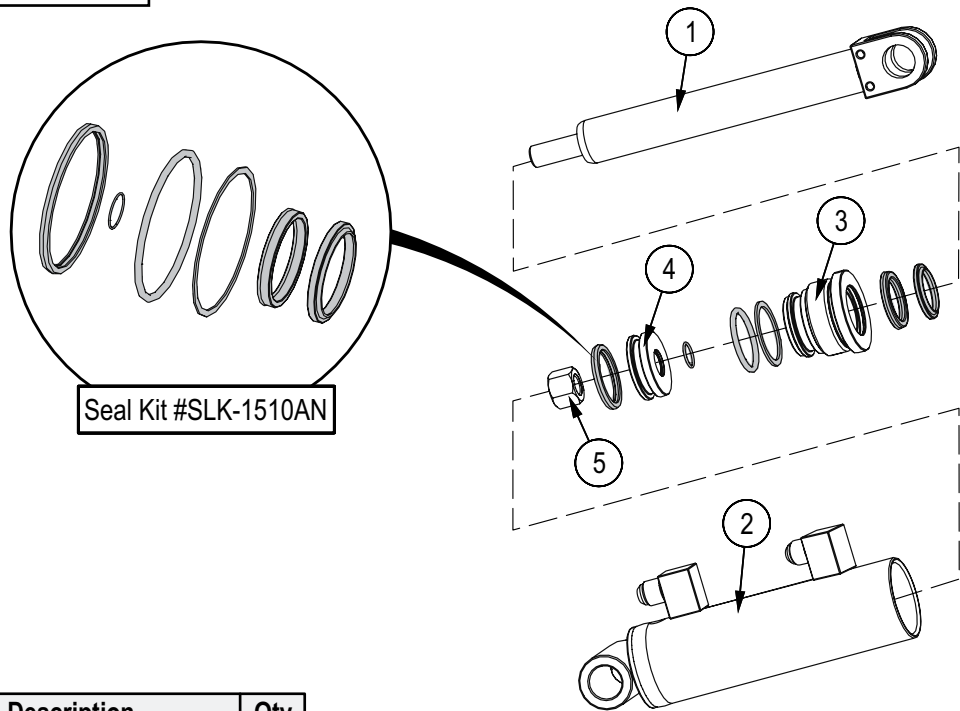

Item No.	Part No.	Description	Qty
1	5089C2023	Rod, 1" x 1/2"	1
2	5089C2024	Barrel, 1-1/2" Bore	1
3	G150-075S	Gland, 1-1/2" X 3/4"	1
4	P500-150SP	Piston, 1-1/2" Bore	1
5	Z72251	Hex Lock Nut, 1/2NC	1

Cylinder / Clutch Plate Assembly – FX85R; S/N 5851–58580

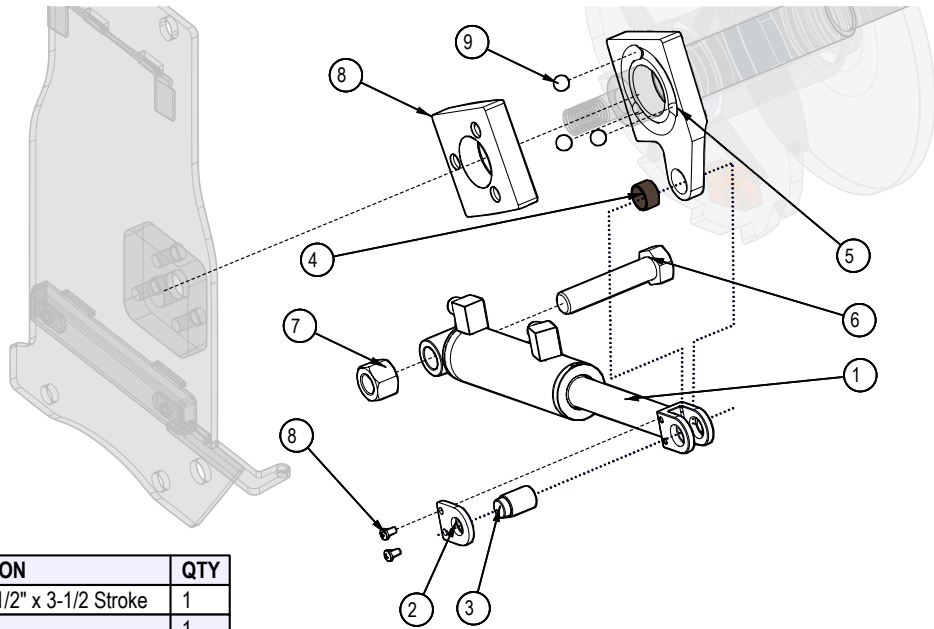

ITEM	PART NUMBER	DESCRIPTION	QTY
1	5089C201	Cylinder, 1-1/2" x 3-1/2 Stroke	1
2	5089L204	Pin Tab	1
3	5089M201	Cylinder Pin	1
4	5089M202	Bushing	1
5	5089M203	Remote Control Clutch Plate	1
6	Z71735	Hex Bolt, 3/4NC x 3-1/2	1
7	Z72271	Hex Lock Nut, 3/4NC	1
8	Z78302	Machine Screw, #10-32NF x 3/8	2
9	5012M212	Clutch Engagment Nut	1
10	Z29101	Roller Ball, 1/2	3

Cylinder / Clutch Plate Assembly – FX85R; S/N 585881 & Up

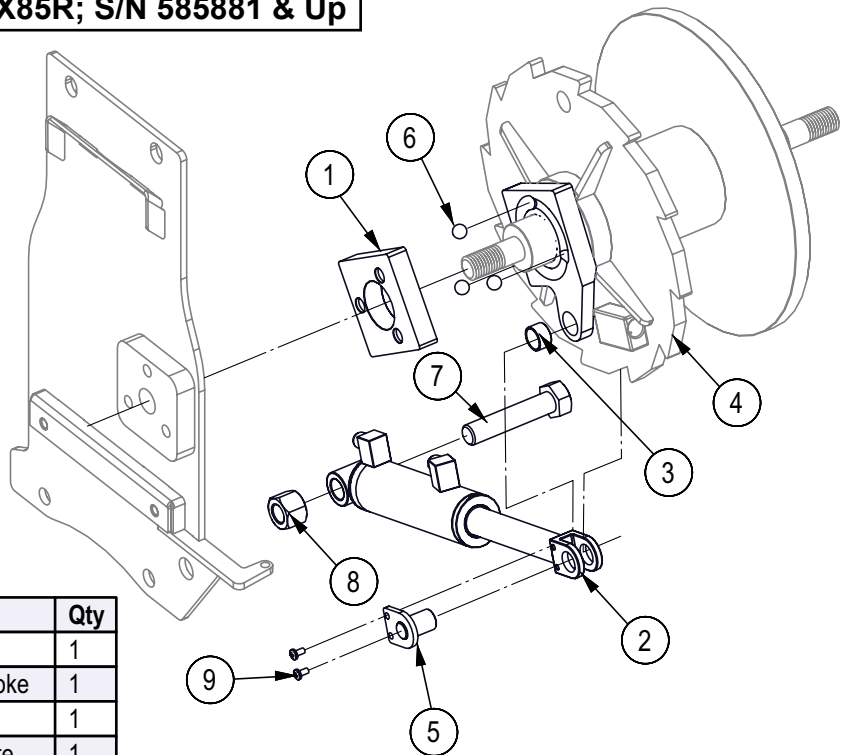

ECN0415

Item	Part Number	Description	Qty
1	5012M212	Clutch Engagment Nut	1
2	5089C202	Cylinder, 1-1/2" x 3-1/2 Stroke	1
3	5089M202	Bushing	1
4	5089M203	Remote Control Clutch Plate	1
5	5089W201	Cylinder Pin	1
6	Z29101	Roller Ball, 1/2	3
7	Z71735	Hex Bolt, 3/4NC x 3-1/2	1
8	Z72271	Hex Lock Nut, 3/4NC	1
9	Z78302	Machine Screw, #10-32NF x 3/8	2

Remote Control Components – FX85R; S/N 5851–58580

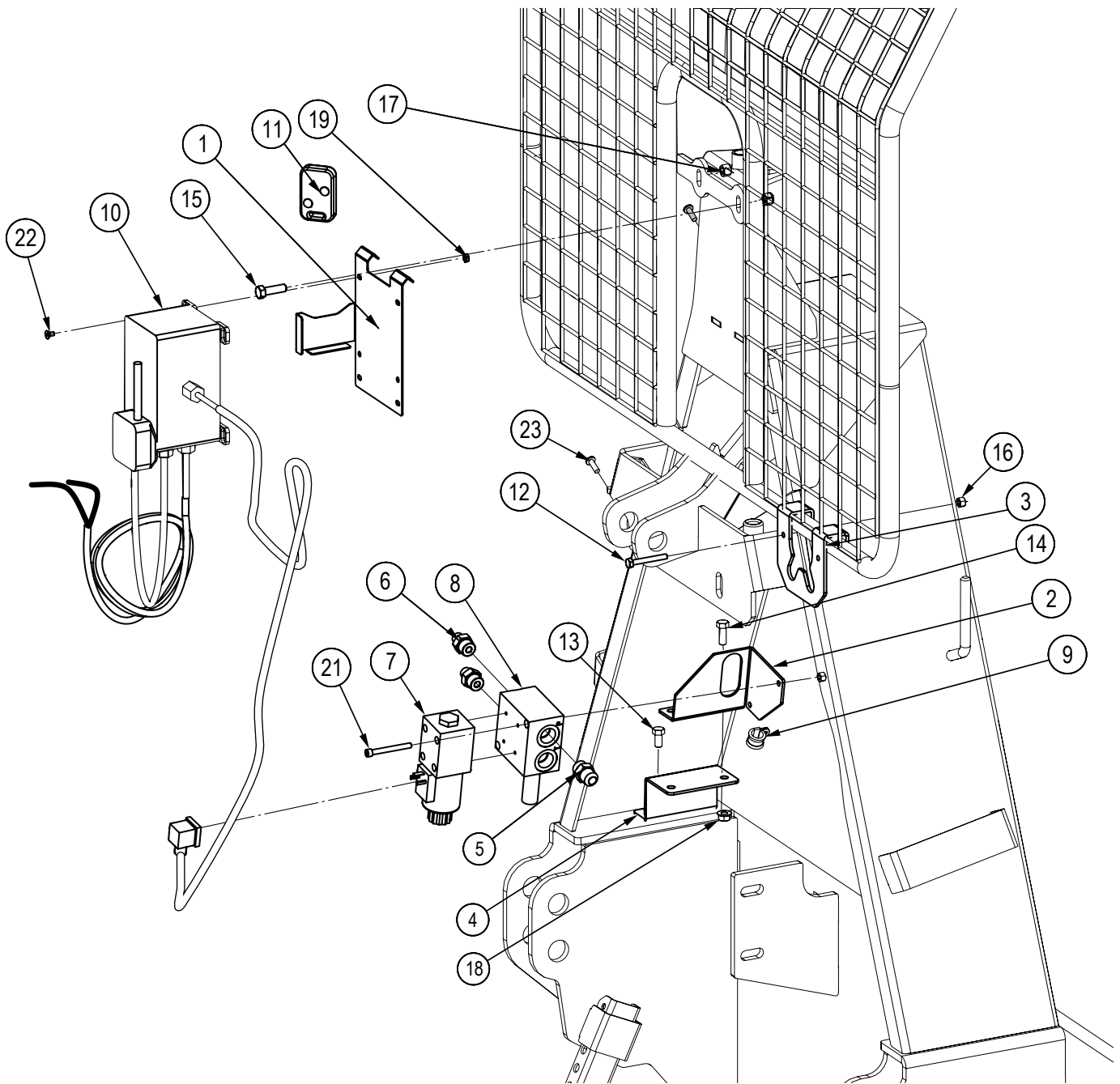

Item	Part Number	Description	Qty
1	5089L217	Remote Box Mount	1
2	5089L208	Hydraulic Mount Base	1
3	5089L209	Hose Hanger	1
4	5089L210	Valve Mount Extension	1
5	Z51643	#8ORB x #8JIC	2
6	Z51644	#8ORB x #6JIC	2
7	Z56509	Solenoid 4-2 Valve - Motor Spool	1
8	Z56510	SubPlate with Relief	1
9	Z62819	Rubberized Wire Clamp, 1/2"	2
10	Z66208	Dual State Remote Receiver	1
11	Z66209	Remote Handset for Z66208	1

Item	Part Number	Description	Qty
12	Z71120	Hex Bolt, 1/4NC x 2	2
13	Z71307	Hex Bolt, 3/8NC x 3/4	2
14	Z71310	Hex Bolt, 3/8NC x 1	2
15	Z71312	Hex Bolt, 3/8NC x 1-1/4	2
16	Z72211	Hex Lock Nut, 1/4NC	6
17	Z72231	Hex Lock Nut, 3/8NC	2
18	Z72531	Flange Nut 3/8NC	4
19	Z72752	Machine Nut, #10-32NF	4
20	Z75102	SHCS, #10-24NC x 1-3/4	4
21	Z75117	SHCS, 1/4NC x 2-1/4	2
22	Z75202	FHCS, #10-32NF x 3/8	4
23	Z78301	Machine Screw, 1/4-20NC x 3/4	2

Remote Control Components – FX85R; S/N 585881 & Up

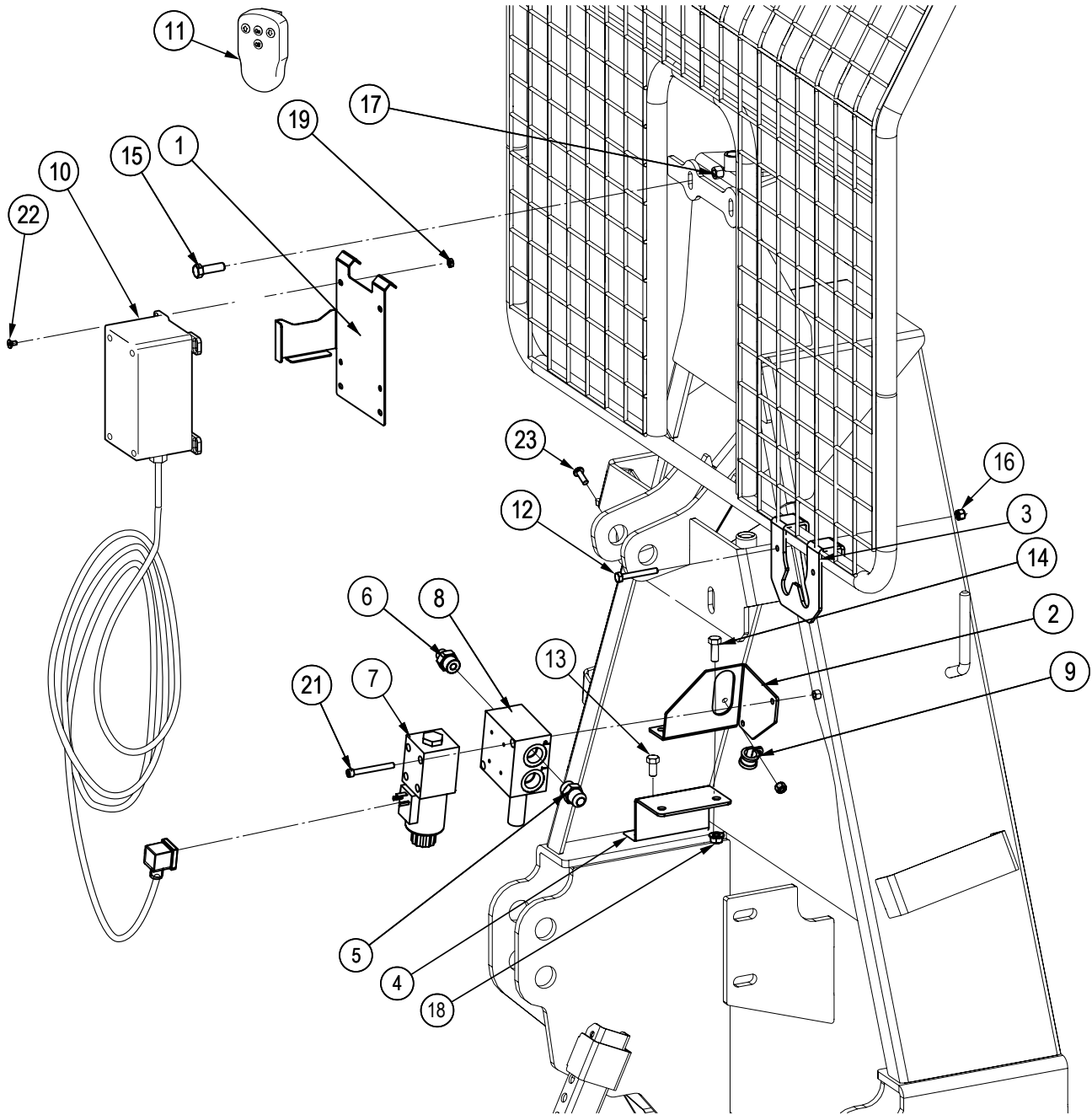

Item	Part Number	Description	Qty
1	5089L217	Remote Box Mount	1
2	5089L208	Hydraulic Mount Base	1
3	5089L209	Hose Hanger	1
4	5089L210	Valve Mount Extension	1
5	Z51643	#8ORB x #8JIC	2
6	Z51644	#8ORB x #6JIC	2
7	Z56509	Solenoid 4-2 Valve - Motor Spool	1
8	Z56510	SubPlate with Relief	1
9	Z62819	Rubberized Wire Clamp, 1/2"	2
10	Z66218	Dual State Remote Receiver	1
11	Z66219	Remote Handset for Z66218	1

Item	Part Number	Description	Qty
12	Z71120	Hex Bolt, 1/4NC x 2	2
13	Z71307	Hex Bolt, 3/8NC x 3/4	2
14	Z71310	Hex Bolt, 3/8NC x 1	2
15	Z71312	Hex Bolt, 3/8NC x 1-1/4	2
16	Z72211	Hex Lock Nut, 1/4NC	6
17	Z72231	Hex Lock Nut, 3/8NC	2
18	Z72531	Flange Nut 3/8NC	4
19	Z72752	Machine Nut, #10-32NF	4
20	Z75102	SHCS, #10-24NC x 1-3/4	4
21	Z75117	SHCS, 1/4NC x 2-1/4	2
22	Z75202	FHCS, #10-32NF x 3/8	4
23	Z78301	Machine Screw, 1/4-20NC x 3/4	2

Hydraulic Plumbing Diagram- FX85R

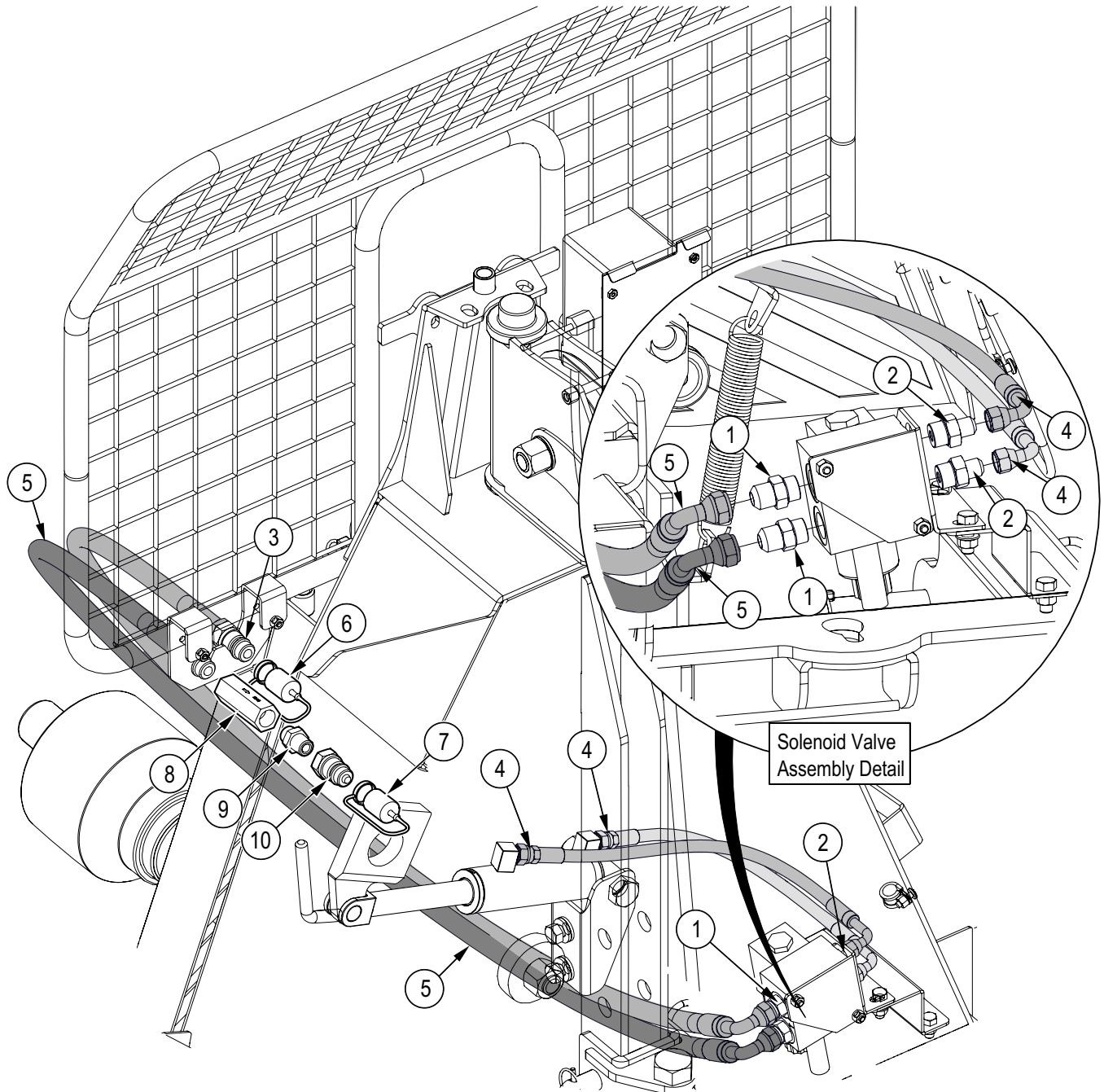

Item No.	Part No.	Description	Qty
1	Z51643	Straight, MJIC x MORB 0808	2
2	Z51644	Straight, MJIC x MORB 0608	2
3	Z51926	Quick Coupler, FP08 x M ISO 7241-1	2
4	Z52124	1/4" Hose, FJIC06 x 90 FJIC06 x 26"	2
5	Z52342	1/2" Hose, 90FJIC08 x MP08 x 60"	2
6	Z52831	Nipple Cap, ISO 7241-1 x Red	1
7	Z52832	Nipple Cap, ISO 7241-1 x Black	1
8	Z56109	Check Valve, ORB08 x 72psi	1
9	Z51615	Straight, MORB x MP 0808	1
10	Z51926	Quick Coupler, FP08 x M ISO 5675 IRV	1

Decal Layout

IMPORTANT! If parts are replaced that have safety signs on them, new signs must be applied. Safety signs must always be replaced if they become damaged, are removed, or become illegible.

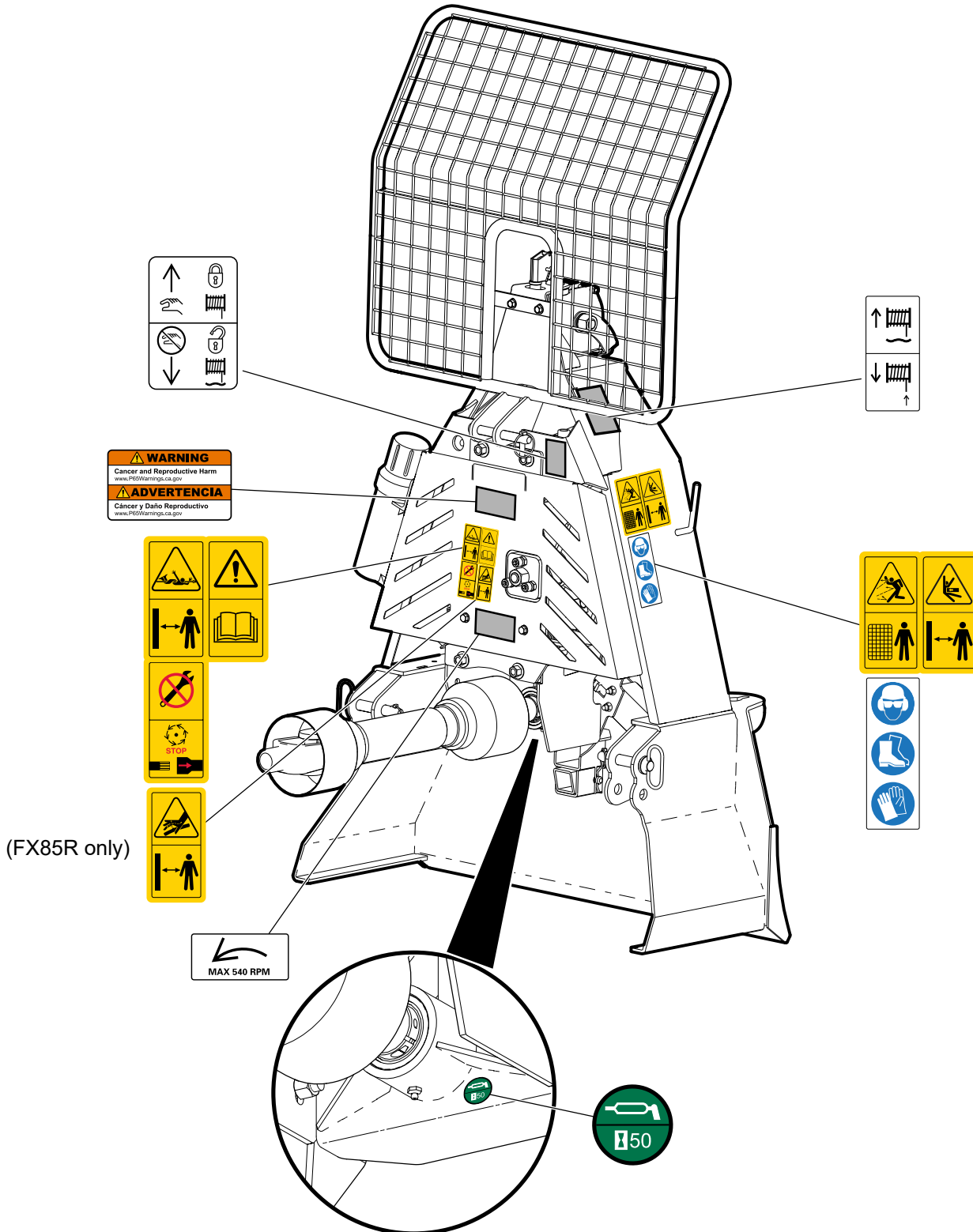

Decal Layout

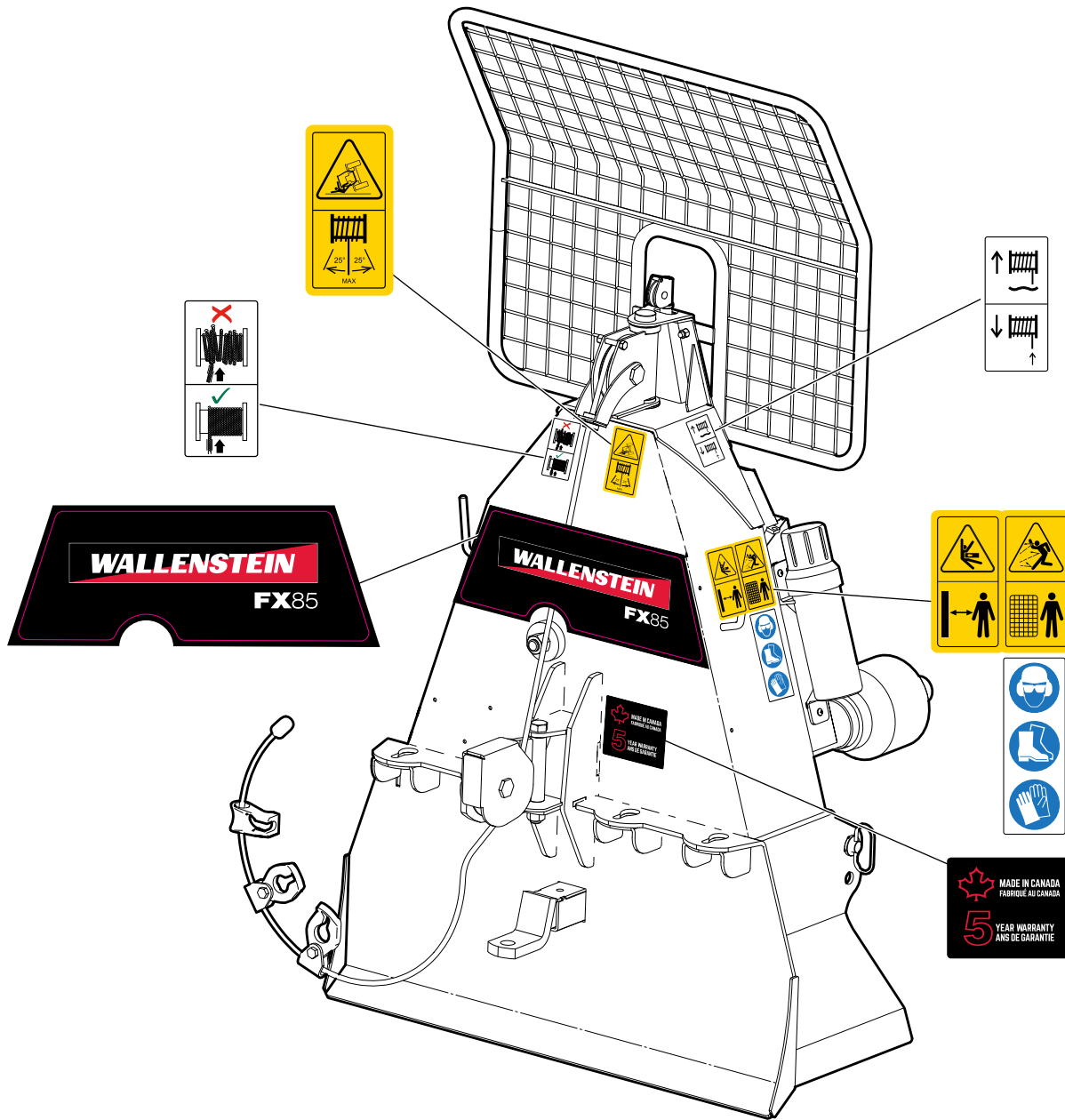

Accessories

Call your dealer for pricing and availability

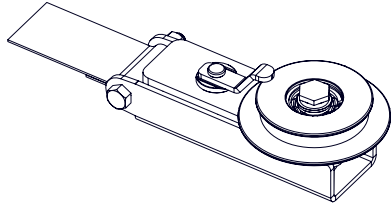

Self Releasing Snatch Block – P/N 5089A100

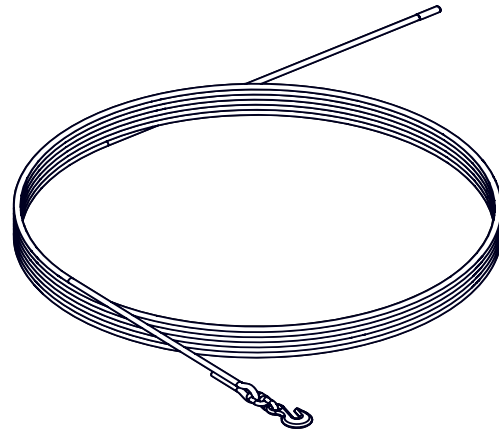

200 ft (61 m) — 7/16" (11 mm) Synthetic Mainline with Hook – P/N Z92123

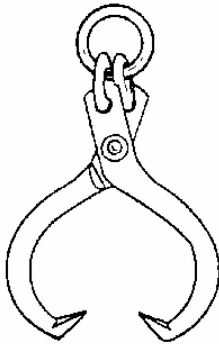

Logging Tongs – P/N Z99003

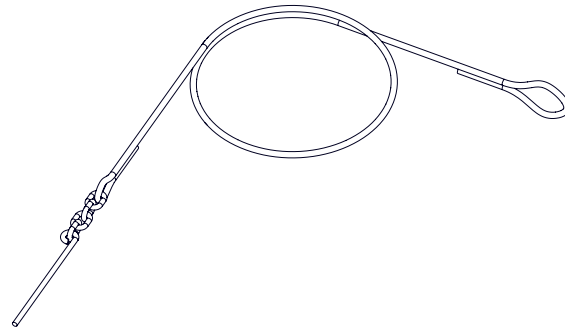

5 ft (1.5 m) Synthetic Choker with Rod Chain End – P/N Z92125

7 ft (2.1 m) Synthetic Choker with Rod Chain End – P/N Z92126

Common Bolt Torque Values

Checking Bolt Torque

The tables shown give correct torque values for various bolts and capscrews. Tighten all bolts to the torque values specified in the table, unless indicated otherwise. Check tightness of bolts periodically.

IMPORTANT! If replacing hardware, use fasteners of the same grade.

IMPORTANT! Torque figures indicated in the table are for non-greased or non-oiled threads. Do not grease or oil threads unless indicated otherwise. When using a thread locker, increase torque values by 5%.

 **NOTE:** Bolt grades are identified by their head markings.

Imperial Bolt Torque Specifications

Bolt Diameter	Torque Value					
	SAE Gr. 2		SAE Gr. 5		SAE Gr. 8	
	lbf•ft	N•m	lbf•ft	N•m	lbf•ft	N•m
1/4"	6	8	9	12	12	17
5/16"	10	13	19	25	27	36
3/8"	20	27	33	45	45	63
7/16"	30	41	53	72	75	100
1/2"	45	61	80	110	115	155
9/16"	60	95	115	155	165	220
5/8"	95	128	160	215	220	305
3/4"	165	225	290	390	400	540
7/8"	170	230	420	570	650	880
1"	225	345	630	850	970	1320



SAE Gr. 2



SAE Gr. 5



SAE Gr. 8

Metric Bolt Torque Specifications

Bolt Diameter	Torque Value			
	Gr. 8.8		Gr. 10.9	
	lbf•ft	N•m	lbf•ft	N•m
M3	0.4	0.5	1.3	1.8
M4	2.2	3	3.3	4.5
M6	7	10	11	15
M8	18	25	26	35
M10	37	50	52	70
M12	66	90	92	125
M14	83	112	116	158
M16	166	225	229	310
M20	321	435	450	610
M30	1,103	1 495	1,550	2 100



8.8



10.9

Hydraulic Fitting Torque Values

Tightening Flare Type Tube Fittings

1. Check flare and flare seat for defects that might cause leakage.
2. Align tube with fitting before tightening.
3. Hand-tighten swivel nut until snug.
4. To prevent twisting the tube, use two wrenches. Place one wrench on the connector body and tighten the swivel nut with the second. Torque to values shown.

If a torque wrench is not available, use the FFFT (Flats From Finger Tight) method.

Hydraulic Fitting Torque					
Tube Size OD	Hex Size Across Flats	Torque value		Flats From Finger Tight	
		lbf•ft	N•m	Flats	Turns
3/16	7/16	6	8	2	1/6
1/4	9/16	11–12	15–17	2	1/6
5/16	5/8	14–16	19–22	2	1/6
3/8	11/16	20–22	27–30	1-1/4	1/6
1/2	7/8	44–48	59–65	1	1/6
5/8	1	50–58	68–79	1	1/6
3/4	1-1/4	79–88	107–119	1	1/8
1	1-5/8	117–125	158–170	1	1/8

Values shown are for non-lubricated connections.