

# SETUP INSTRUCTIONS

---

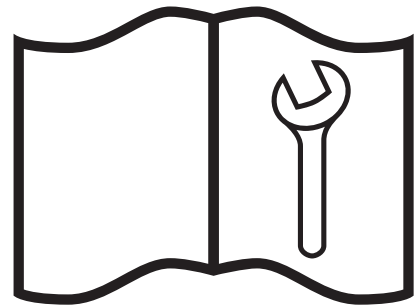

**WXT15H**

**WXT20H**

## Safety

### WARNING!

Do not assemble the machine before you read the assembly instructions in this manual. Make sure that you understand the safety information and each step of the procedure before you assemble the machine.

Keep this manual with you and available for frequent reference as you assemble the machine.

### WARNING!

Use a hoist when to lift machine components that weigh 50 lb (23 kg) or more. Do not lift machine components that weigh more than you can lift without strain or injury.

### WARNING!

Use lift equipment with a lift capacity that is more than the weight of the machine component. Put jack stands or wood blocks under the machine to make it safe while you assemble the machine.

### WARNING!

Use the correct tools and equipment to assemble the machine. The use of incorrect tools can create safety hazards. A tool that breaks or slips during assembly risks personal injury. Repair or replace equipment or tools that are broken or defective.

### WARNING!

All lifting equipment (for example, straps, slings, chains, or ratchet blocks) must comply with the applicable local laws, standards, and regulations. Wallenstein Equipment does not accept responsibility for the use of unsafe equipment and work practices.

### WARNING!

Know the location of and keep away from overhead power lines and obstructions when you lift the machine. Contact with power lines can cause electrocution. Contact with overhead obstructions can damage the machine or components.

### WARNING!

Do not start or operate the machine before you read the Operator's Manual. Make sure that you fully understand all safety, operation, and maintenance information before you operate the machine.

Keep the Operator's Manual with the machine at all times and available for frequent reference.

### WARNING!

Make sure that all the fasteners are installed and torqued to the correct specifications. For more information, see *Specifications on page 11*.

### CAUTION!

Keep the assembly area clean and free of debris to prevent slips, trips, or falls.

**IMPORTANT!** Inspect the machine for damage from shipping. Contact the shipping company immediately if you find any damage to the machine.



Some components are attached to the skid with screws. Make sure that you only discard the shipping brackets.

Put the crate in a large, open area so that you can access the machine components from all sides during assembly.

Learn what the safety labels mean and know the safety hazards.

WXT15H

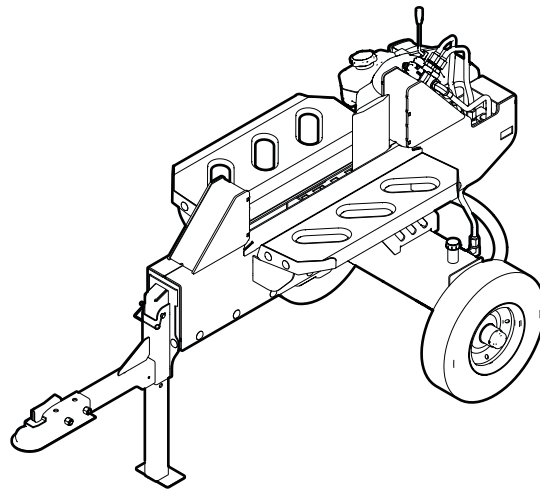

WXT15H

WXT20H

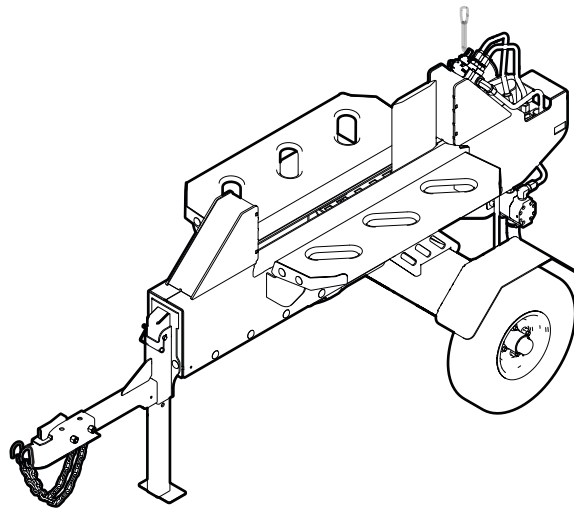

WXT20H

The assembly hardware is inside the Operator's Manual storage tube.

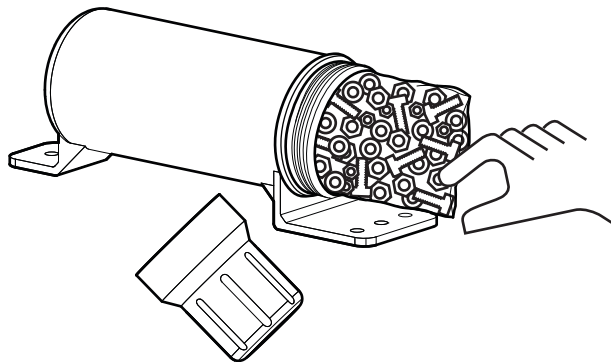

i

1

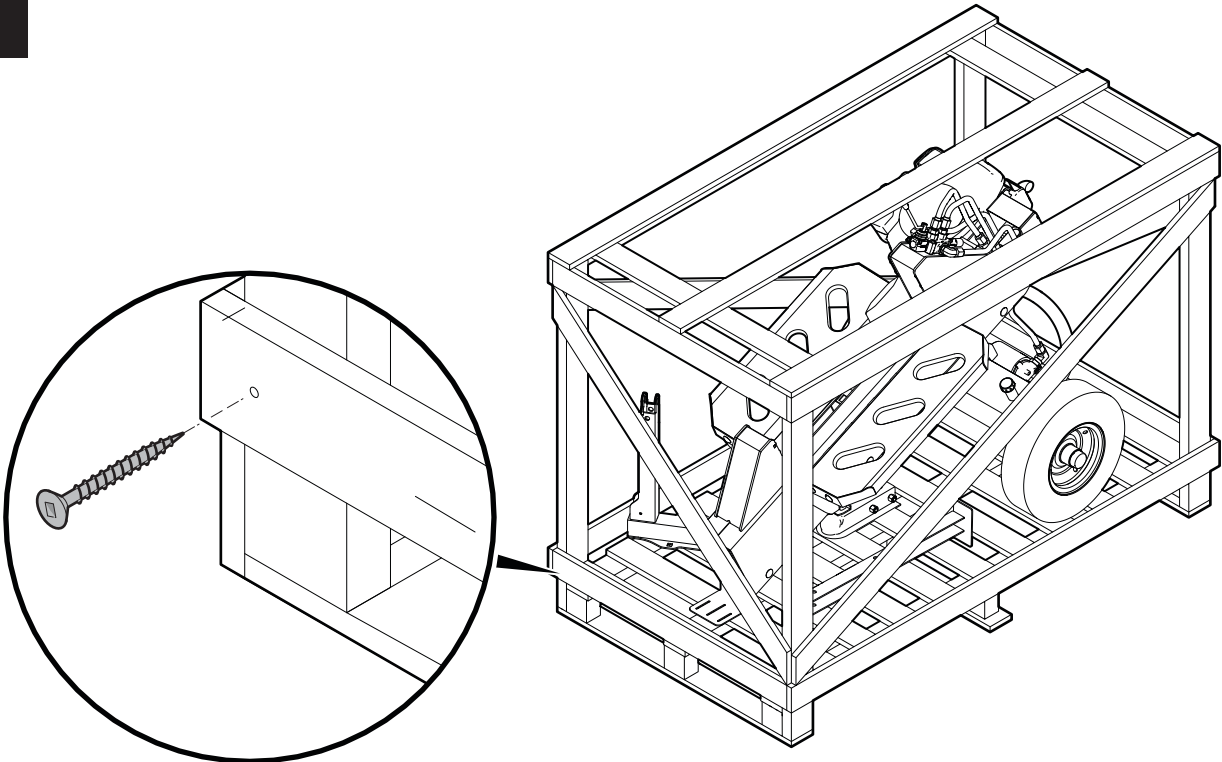

2

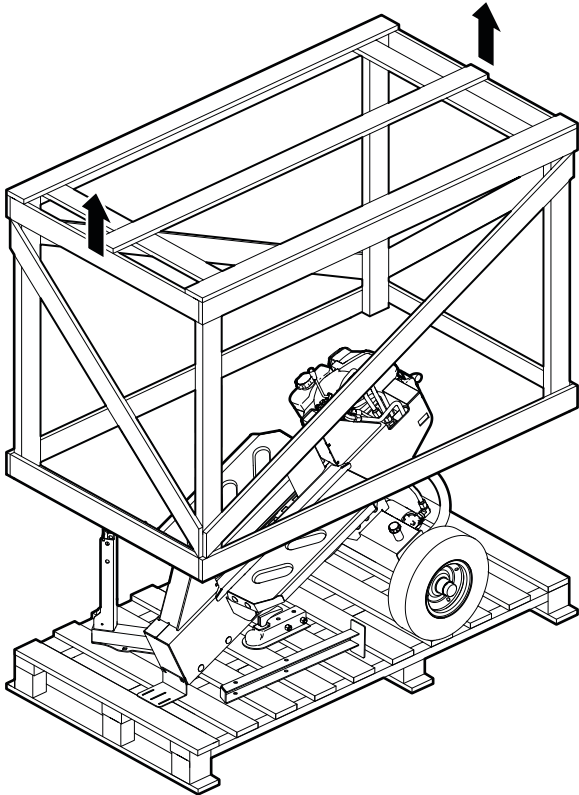

3

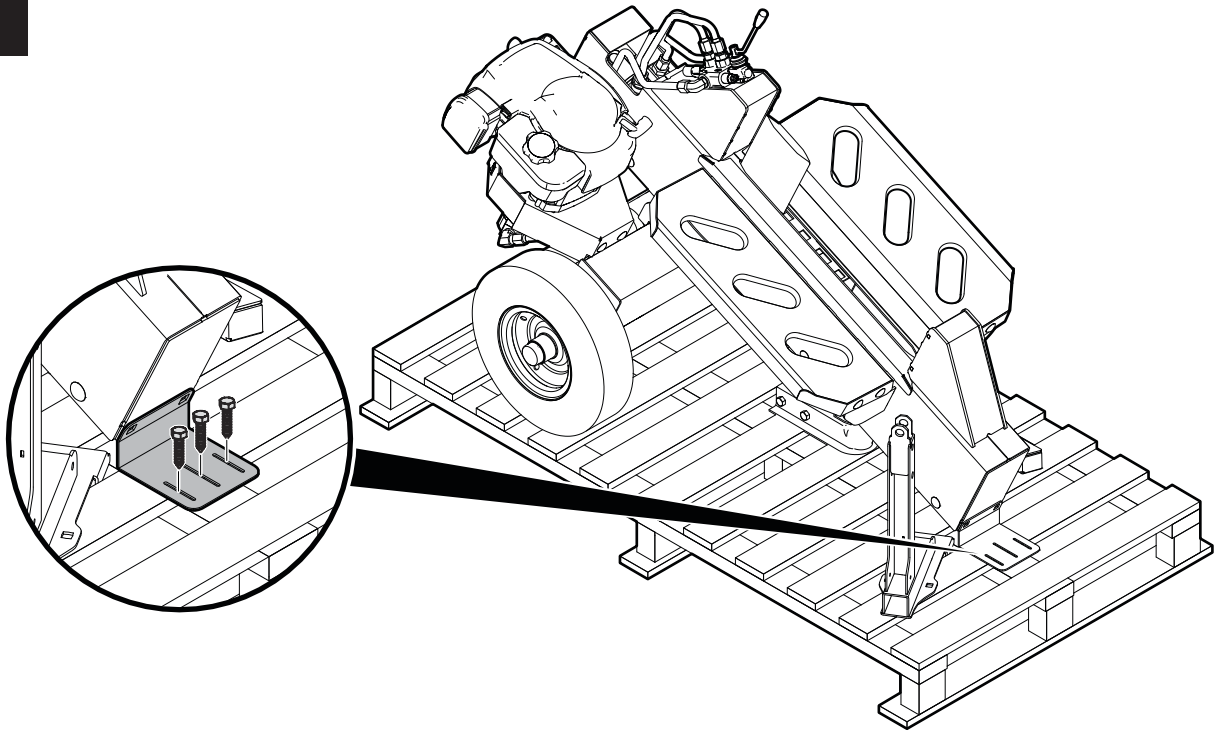

4

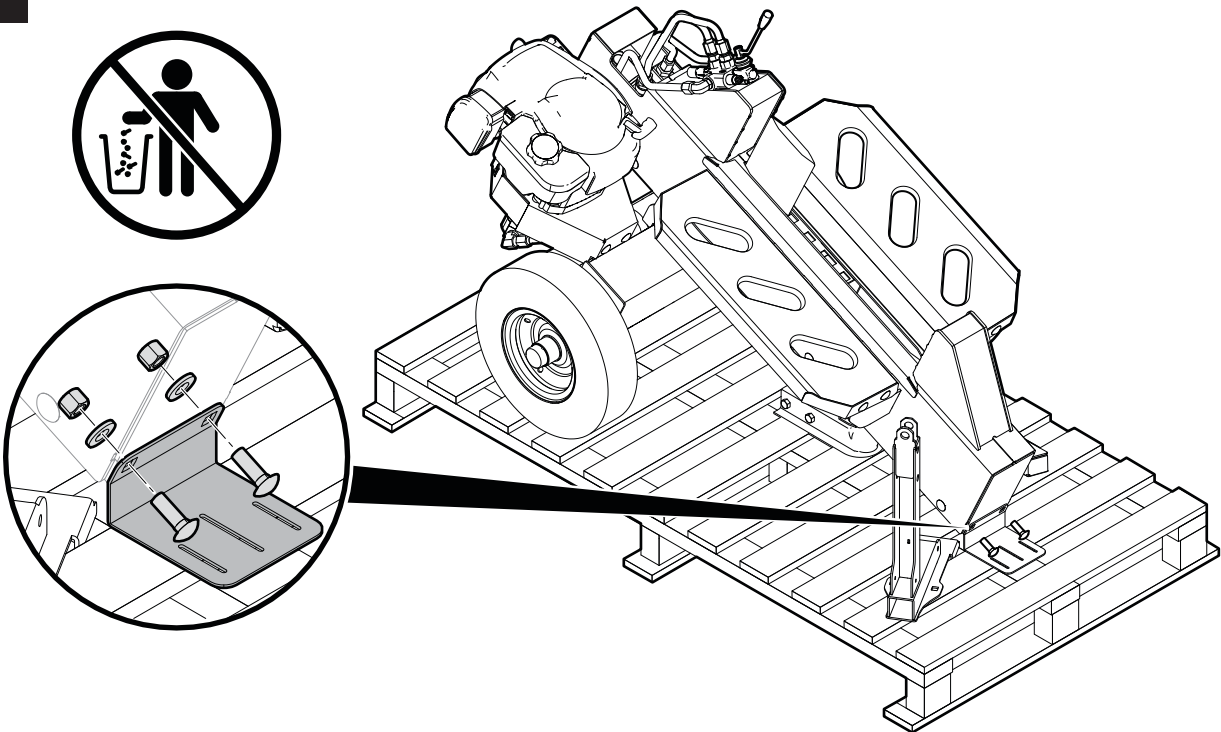

5

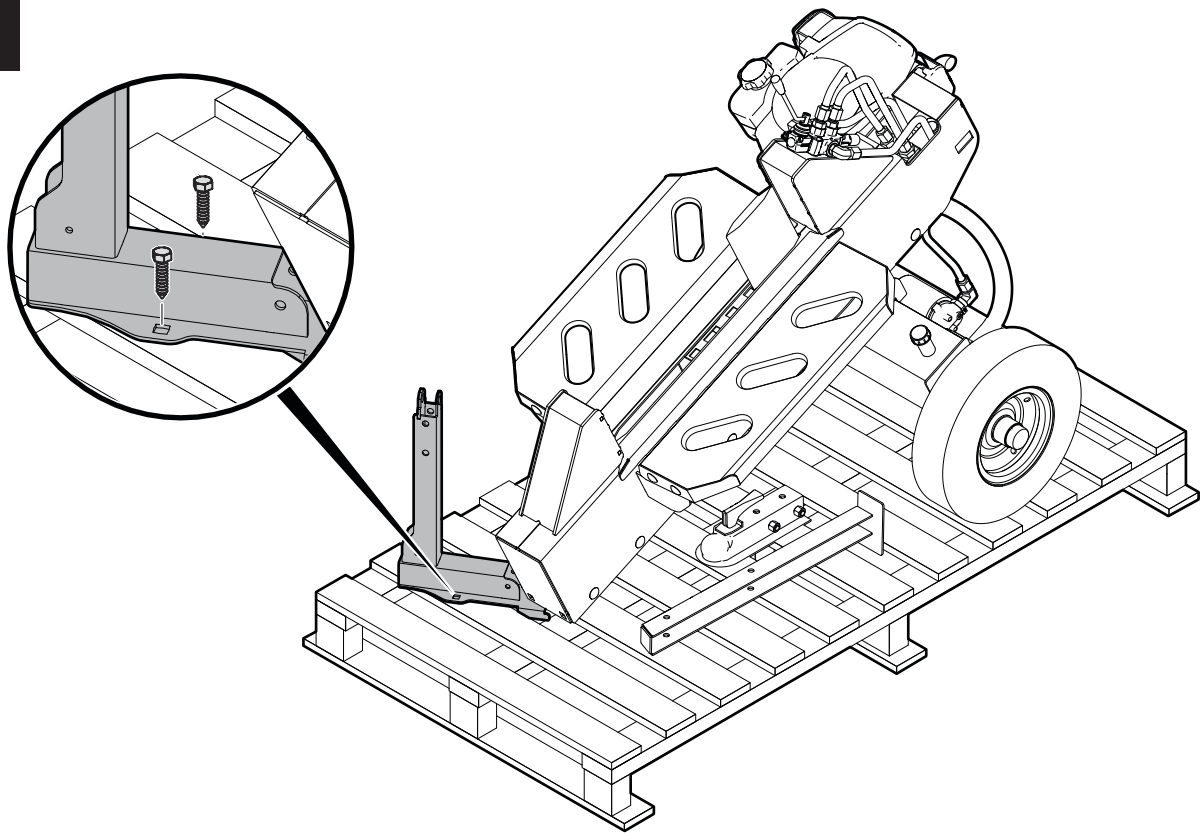

6

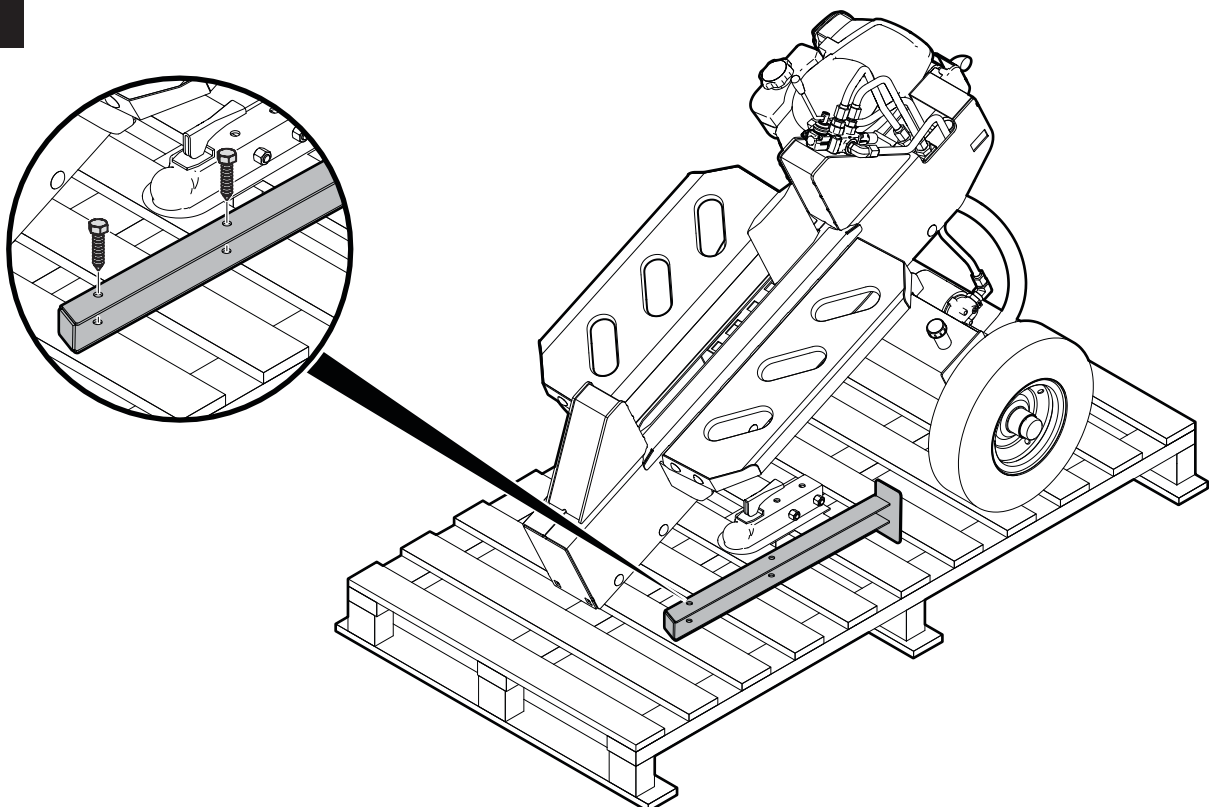

7

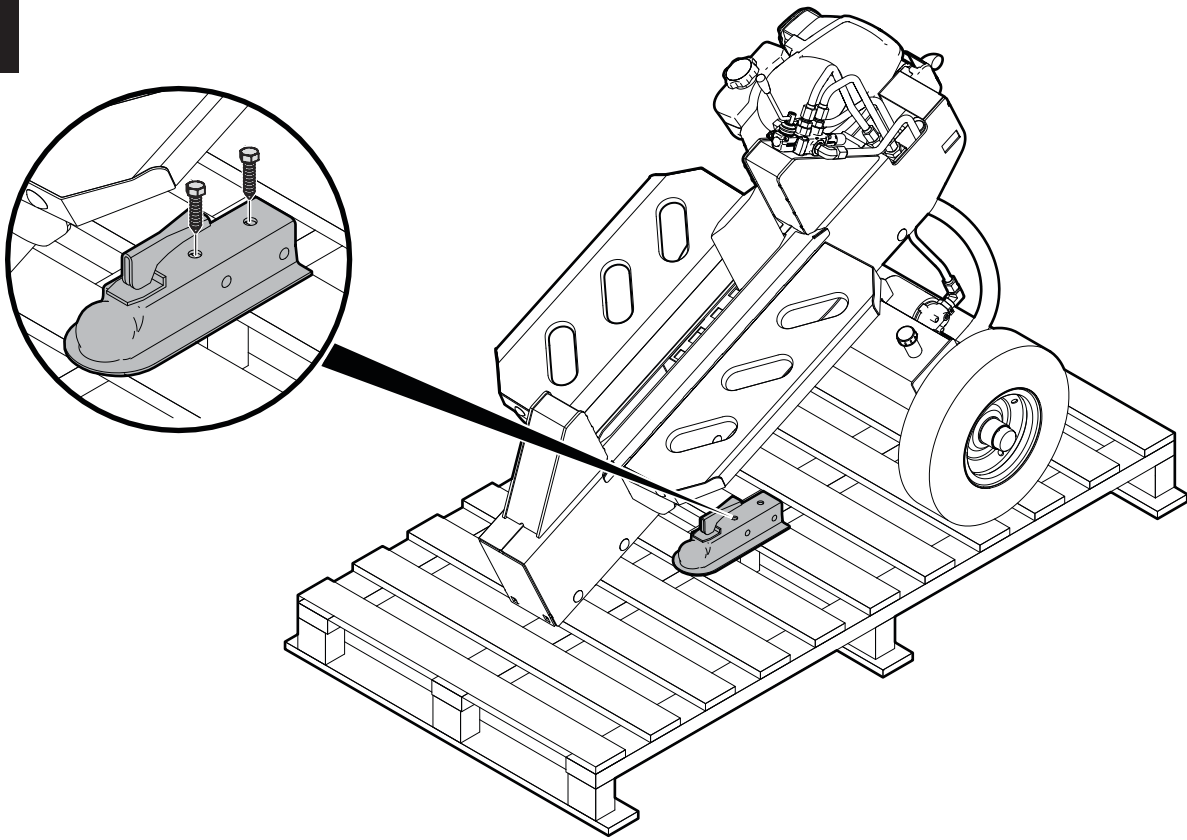

8

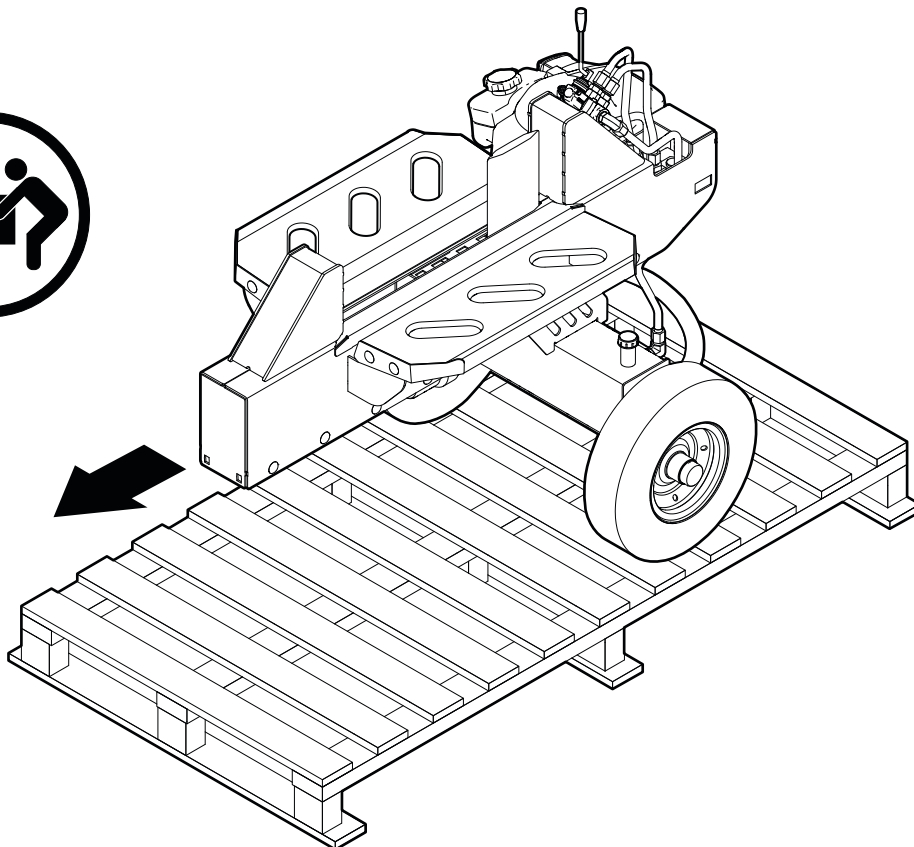

9

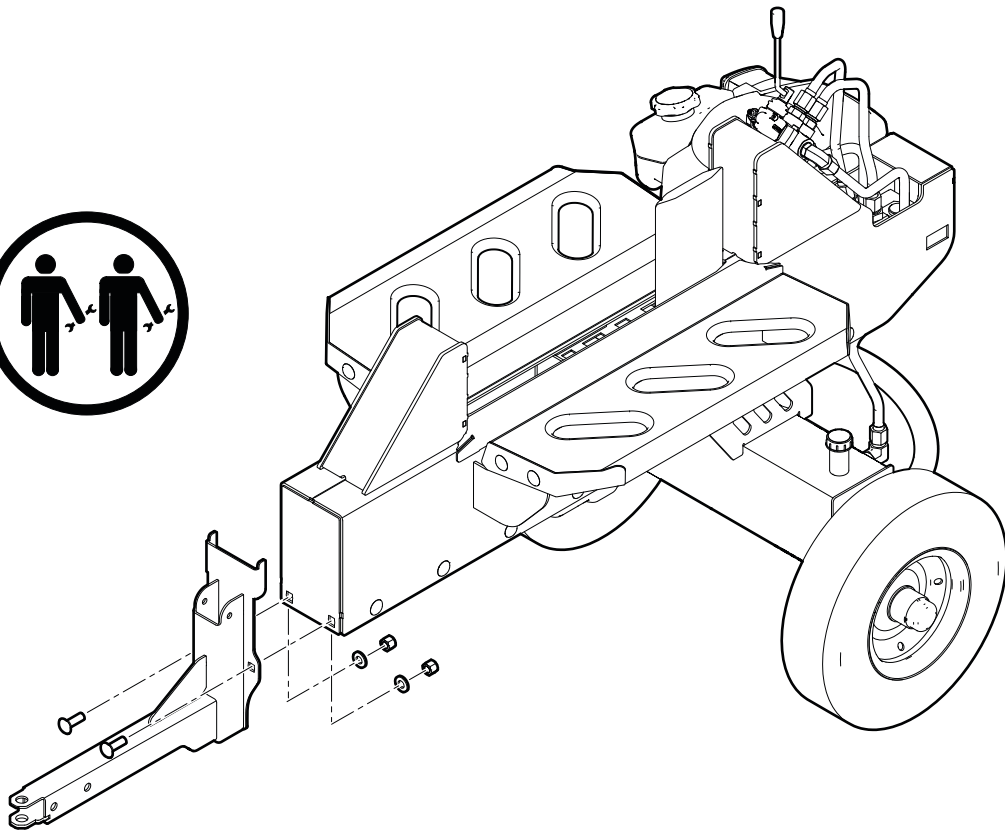
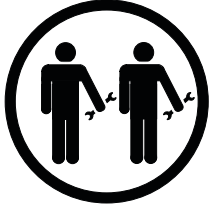

10

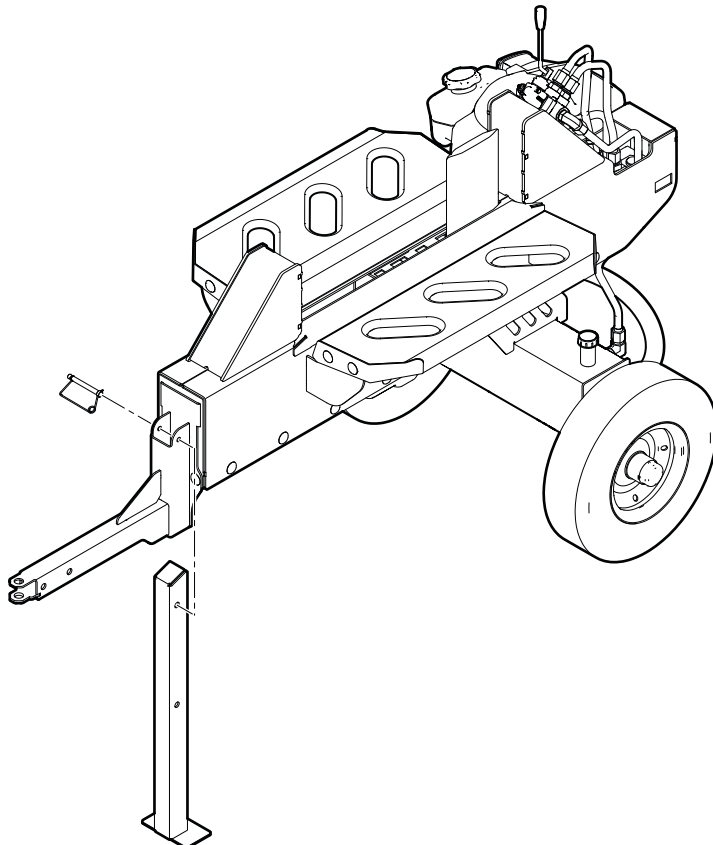
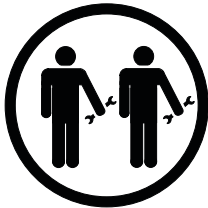



**11**

**WXT15H**

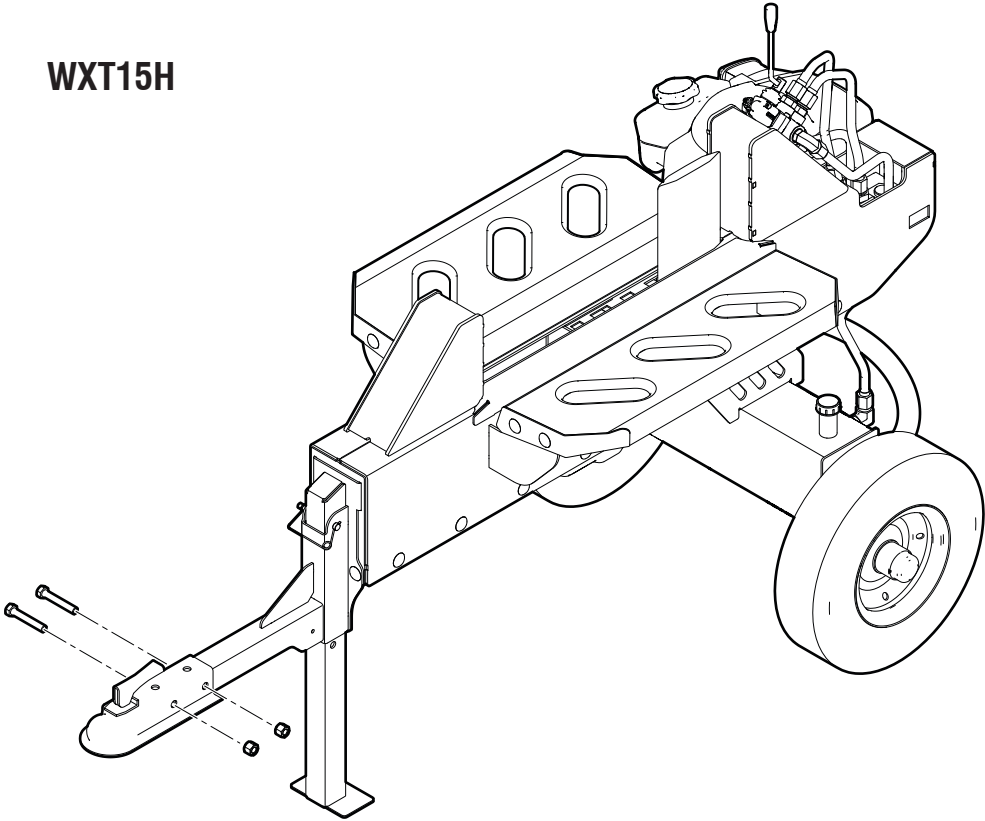

**WXT20H**

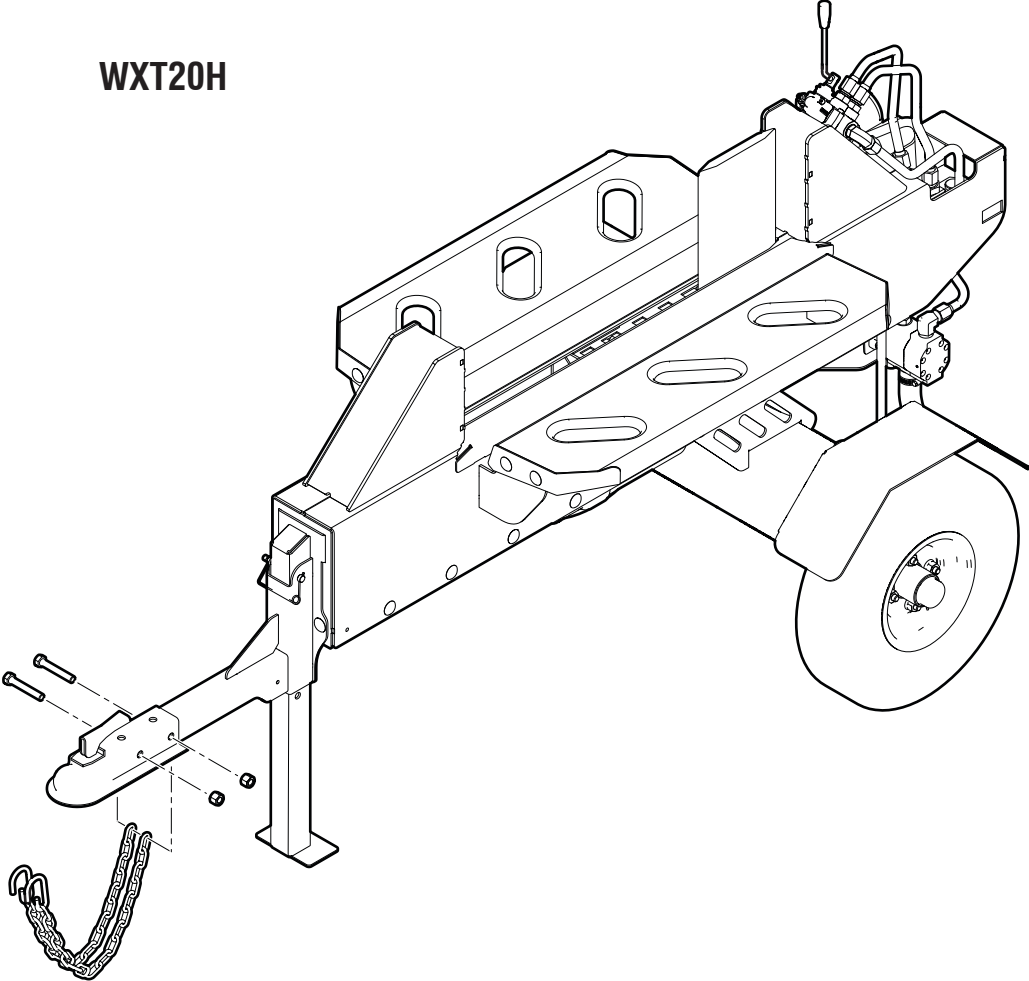

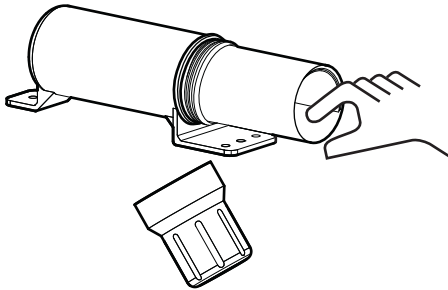
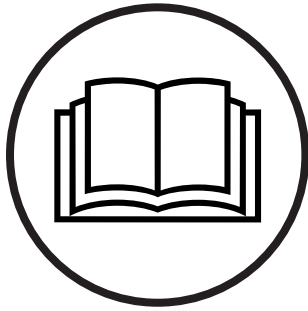

## Pre-delivery Inspection Checklist

Do the following pre-delivery inspections (PDI).

- \_\_\_\_\_ All support stands move freely.
- \_\_\_\_\_ Machine controls function correctly.
- \_\_\_\_\_ All fasteners are torqued to the correct specifications.
- \_\_\_\_\_ All grease points are lubricated.
- \_\_\_\_\_ Purchased accessories are included, if applicable.
- \_\_\_\_\_ Operator's Manual is in the document tube.
- \_\_\_\_\_ Hydraulic system and cylinders function correctly.
- \_\_\_\_\_ Hydraulic controls move freely.
- \_\_\_\_\_ Hydraulic fluid reservoir level is correct.
- \_\_\_\_\_ Hydraulic connections are tight, and hoses and fittings are in good condition.
- \_\_\_\_\_ There are no hydraulic leaks.
- \_\_\_\_\_ Engine starts and operates, and fluid levels are correct.
- \_\_\_\_\_ Tire pressure is correct (see the tire sidewall).
- \_\_\_\_\_ Tires are in working condition.

### Safety Checks

- \_\_\_\_\_ All safety labels are applied and legible.
- \_\_\_\_\_ All guards, shields are installed and the covers are closed.
- \_\_\_\_\_ Wheel lug nuts are tightened to the correct torque.
- \_\_\_\_\_ A retainer is installed through each hitch point.
- \_\_\_\_\_ Operating and safety instructions were reviewed.
- \_\_\_\_\_ Rear reflectors are present and not damaged.

### WXT20H

- \_\_\_\_\_ Safety chains are on the ball-mount hitch.
- \_\_\_\_\_ If purchased, all lights operate correctly (for example, running, brake, turn signal, license plate).

# Specifications

## Bolt Torque

**IMPORTANT!** If you replace hardware, use fasteners of the same grade.

**IMPORTANT!** The torque specifications in these tables are for non-greased or non-oiled threads. Do not grease or oil fastener threads unless otherwise indicated. When using a thread lock, increase the specified torque 5%.



Bolt grades are identified by the marks on top of the bolt head.

These bolt torque specification tables give the correct torque settings for common bolts and capscrews. Tighten all bolts to the torque that is specified in the table, unless otherwise indicated. Check the bolt tightness periodically.

### Imperial Bolt Torque Specifications

Bolt Diameter	Torque					
	SAE Gr. 2		SAE Gr. 5		SAE Gr. 8	
	lbf•ft	N•m	lbf•ft	N•m	lbf•ft	N•m
1/4 inch	6	8	9	12	12	17
5/16 inch	10	13	19	25	27	36
3/8 inch	20	27	33	45	45	63
7/16 inch	30	41	53	72	75	100
1/2 inch	45	61	80	110	115	155
9/16 inch	60	95	115	155	165	220
5/8 inch	95	128	160	215	220	305
3/4 inch	165	225	290	390	400	540
7/8 inch	170	230	420	570	650	880



SAE Gr. 2



SAE Gr. 5



SAE Gr. 8

### Metric Bolt Torque Specifications

Bolt Diameter	Torque			
	Gr. 8.8		Gr. 10.9	
	lbf•ft	N•m	lbf•ft	N•m
M3	0.4	0.5	1.3	1.8
M4	2.2	3	3.3	4.5
M6	7	10	11	15
M8	18	25	26	35
M10	37	50	52	70
M12	66	90	92	125
M14	83	112	116	158
M16	166	225	229	310
M20	321	435	450	610
M30	1,103	1,495	1,550	2,100



8.8



10.9

## Lug Nut Torque

### WARNING!

**Wheel lug nuts must be installed and kept at the correct torque to prevent loose wheels, broken studs, or possible separation of a wheel from the axle.**

It is an extremely important safety procedure to apply and maintain the correct torque on lug nuts that secure the wheel to the trailer axle. A calibrated torque wrench is the best tool to make sure that the correct amount of torque is applied to a fastener.

Tighten wheel lug nuts to the correct torque before the first use and after each wheel removal. After a wheel is installed, check and torque the lug nuts after the first 10 miles (16 km), 25 miles (40 km), and 50 miles (80 km). Check the lug nut torque periodically thereafter.

- Start all lug nuts onto the threads by hand.
- Tighten lug nuts in stages, following the pattern shown below the Lug Nut Torque Specifications table.

### Lug Nut Torque Specifications

Wheel size	Units	First stage	Second stage	Third stage
8 inch	lbf•ft N•m	12–20 16–26	30–35 39–45.5	45–55 58.5–71.5
12 inch	lbf•ft N•m	20–25 26–32.5	35–40 45.5–52	50–60 65–78
13 inch	lbf•ft N•m	20–25 26–32.5	35–40 45.5–52	50–60 65–78
14 inch	lbf•ft N•m	20–25 26–32.5	50–60 65–78	90–120 117–156
15 inch	lbf•ft N•m	20–25 26–32.5	50–60 65–78	90–120 117–156
16 inch	lbf•ft N•m	20–25 26–32.5	50–60 65–78	90–120 117–156

Lug nut torque pattern:

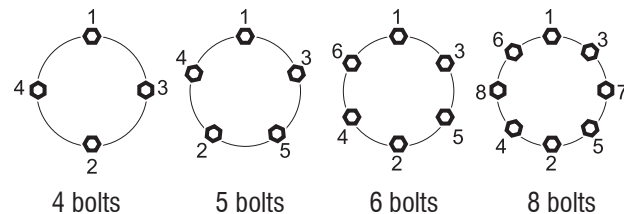



A series of 20 horizontal lines spanning the width of the page, providing a template for writing.



**MAKING WORK FEEL MORE LIKE PLAY™**

[WallensteinEquipment.com](http://WallensteinEquipment.com)

