



EMB Manufacturing Inc.  
4144 Boomer Line · St. Clements, On · N0B 2M0 · Canada  
Ph: (519) 699-9283 · Fax: (519) 699-4146  
www.embmfg.com

# WP830 Wood Processor

## Parts Manual

S/N 2E9US1111ES062358 & After

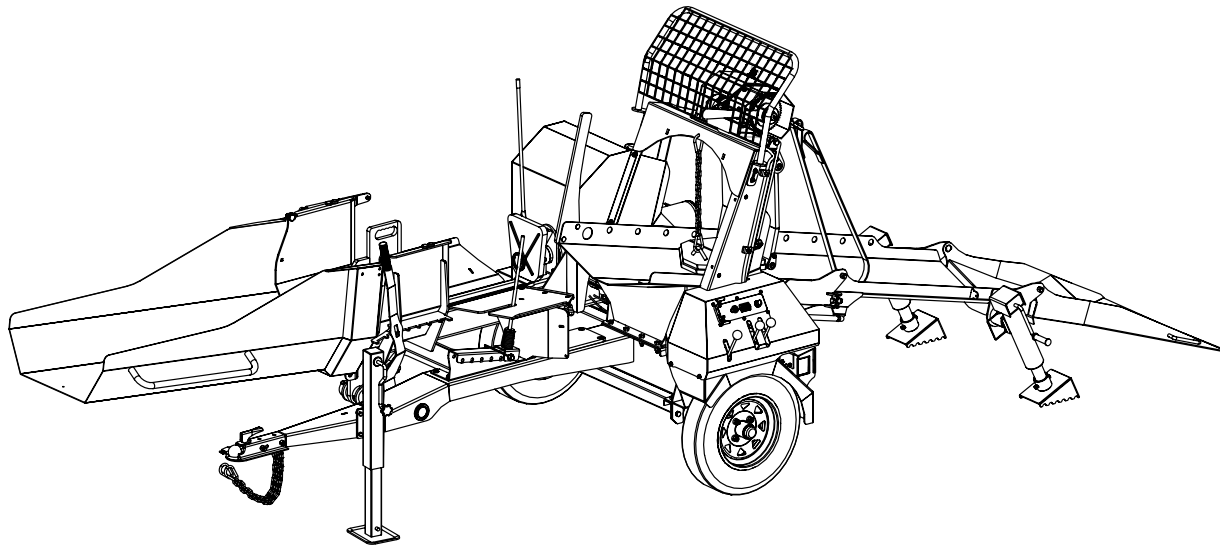

Refer to the operators  
manual for safe opera-  
tion and maintainance

2071T100 WP830 RevG Parts Manual.180615

Rev G 051015

# Table of Contents

## Contents

<b>BOLT TORQUE .....</b>	<b>3</b>
<b>HYDRAULIC FITTING TORQUE.....</b>	<b>4</b>
<b>SPLITTER CHUTE ASS'Y.....</b>	<b>5</b>
<b>LEAD IN CHUTE ASS'Y.....</b>	<b>6</b>
<b>SPLITTER CRADLE ASS'Y .....</b>	<b>7</b>
<b>LOG CHUTE ASS'Y .....</b>	<b>8</b>
<b>RUNNING GEAR.....</b>	<b>9</b>
<b>HUB ASSEMBLY DETAIL .....</b>	<b>10</b>
<b>ENGINE &amp; PUMP ASS'Y.....</b>	<b>11</b>
<b>HYDRAULIC LINES .....</b>	<b>12</b>
<b>HYDRAULIC SPLITTER ASS'Y .....</b>	<b>13</b>
<b>HYDRAULIC VALVES .....</b>	<b>14</b>
<b>HYDRAULIC CYLINDER .....</b>	<b>15</b>
<b>HYDRAULIC CYLINDER SEAL KIT #SLK-4525.....</b>	<b>15</b>
<b>HYDRAULIC WINCH.....</b>	<b>16</b>
<b>WINCH DRUM DETAIL .....</b>	<b>17</b>
<b>WINCH FAIRLEAD DETAIL .....</b>	<b>17</b>
<b>LABELS .....</b>	<b>18</b>
<b>CONTROL PANEL LABELS .....</b>	<b>18</b>
<b>WIRING DIAGRAM .....</b>	<b>19</b>
<b>HYDRAULIC SCHEMATIC.....</b>	<b>20</b>
<b>ACCESSORIES.....</b>	<b>21</b>

## Foreword

EMB Mfg. has prepared this parts manual to assist customers in ordering quality OEM replacement parts.

Proper and regular service and replacing old, worn or broken parts with the correct OEM parts are essential to prolonging the life of your EMB product. Please refer to this manual before ordering any replacement parts.

All information contained in this parts manual is based on the latest product specification available at the time of printing this manual. If your product differs from the specifications contained within this manual contact EMB Mfg. for information.

EMB reserves the right to alter specifications on their products at any time.

Reproduction of this parts manual of any kind is prohibited without prior written permission from EMB Mfg.



Refer to the operators manual for safe operation and maintainance

For parts and information please contact your dealer. If your dealer is no longer available please go to our website: <http://www.embmfg.com> and click on "FIND A DEALER NEAR YOU" for information on a local dealer.

**Bolt Torque**

**CHECKING BOLT TORQUE**

The tables shown below give correct torque values for various bolts and capscrews. Tighten all bolts to the torques specified in chart unless otherwise noted. Check tightness of bolts periodically, using bolt torque chart as a guide. Replace hardware with the same strength bolt.

Torque figures indicated above are valid for non-greased or non-oiled threads and heads unless otherwise specified. Therefore, do not grease or oil bolts or capscrews unless otherwise specified in this manual. When using locking elements, increase torque values by 5%.

\* Torque value for bolts and capscrews are identified by their head markings.

**ENGLISH TORQUE SPECIFICATIONS**

Bolt Diameter "A"	Bolt Torque*					
	SAE 2 (N.m) (lb-ft)		SAE 5 (N.m) (lb-ft)		SAE 8 (N.m) (lb-ft)	
1/4"	8	6	12	9	17	12
5/16"	13	10	25	19	36	27
3/8"	27	20	45	33	63	45
7/16"	41	30	72	53	100	75
1/2"	61	45	110	80	155	115
9/16"	95	60	155	115	220	165
5/8"	128	95	215	160	305	220
3/4"	225	165	390	290	540	400
7/8"	230	170	570	420	880	650
1"	345	225	850	630	1320	970



**METRIC TORQUE SPECIFICATIONS**

Bolt Diameter "A"	Bolt Torque*			
	8.8 (N.m) (lb-ft)		10.9 (N.m) (lb-ft)	
M3	.5	.4	1.8	1.3
M4	3	2.2	4.5	3.3
M5	6	4	9	7
M6	10	7	15	11
M8	25	18	35	26
M10	50	37	70	52
M12	90	66	125	92
M14	140	103	200	148
M16	225	166	310	229
M20	435	321	610	450
M24	750	553	1050	774
M30	1495	1103	2100	1550
M36	2600	1917	3675	2710

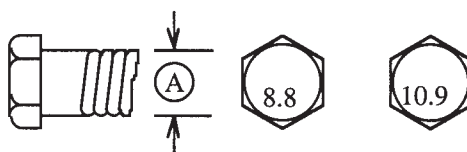

**Hydraulic Fitting Torque****Tightening Flare Type Tube Fittings \***

1. Check flare and flare seat for defects that might cause leakage.
2. Align tube with fitting before tightening.
3. Lubricate connection and hand tighten swivel nut until snug.
4. To prevent twisting the tube(s), use two wrenches. Place one wrench on the connector body and with the second tighten the swivel nut to the torque shown.

Tube Size OD	Nut Size Across Flats	Torque Value*		Recommended Turns To Tighten (After Finger Tightening)	
		(N.m)	(lb-ft)	(Flats)	(Turn)
3/16	7/16	8	6	1	1/6
1/4	9/16	12	9	1	1/6
5/16	5/8	16	12	1	1/6
<b>3/8</b>	<b>11/16</b>	<b>24</b>	<b>18</b>	<b>1</b>	<b>1/6</b>
1/2	7/8	46	34	1	1/6
5/8	1	62	46	1	1/6
3/4	1-1/4	102	75	3/4	1/8
7/8	1-3/8	122	90	3/4	1/8

The torque values shown are based on lubricated connections as in reassembly.

**Splitter Chute Ass'y**

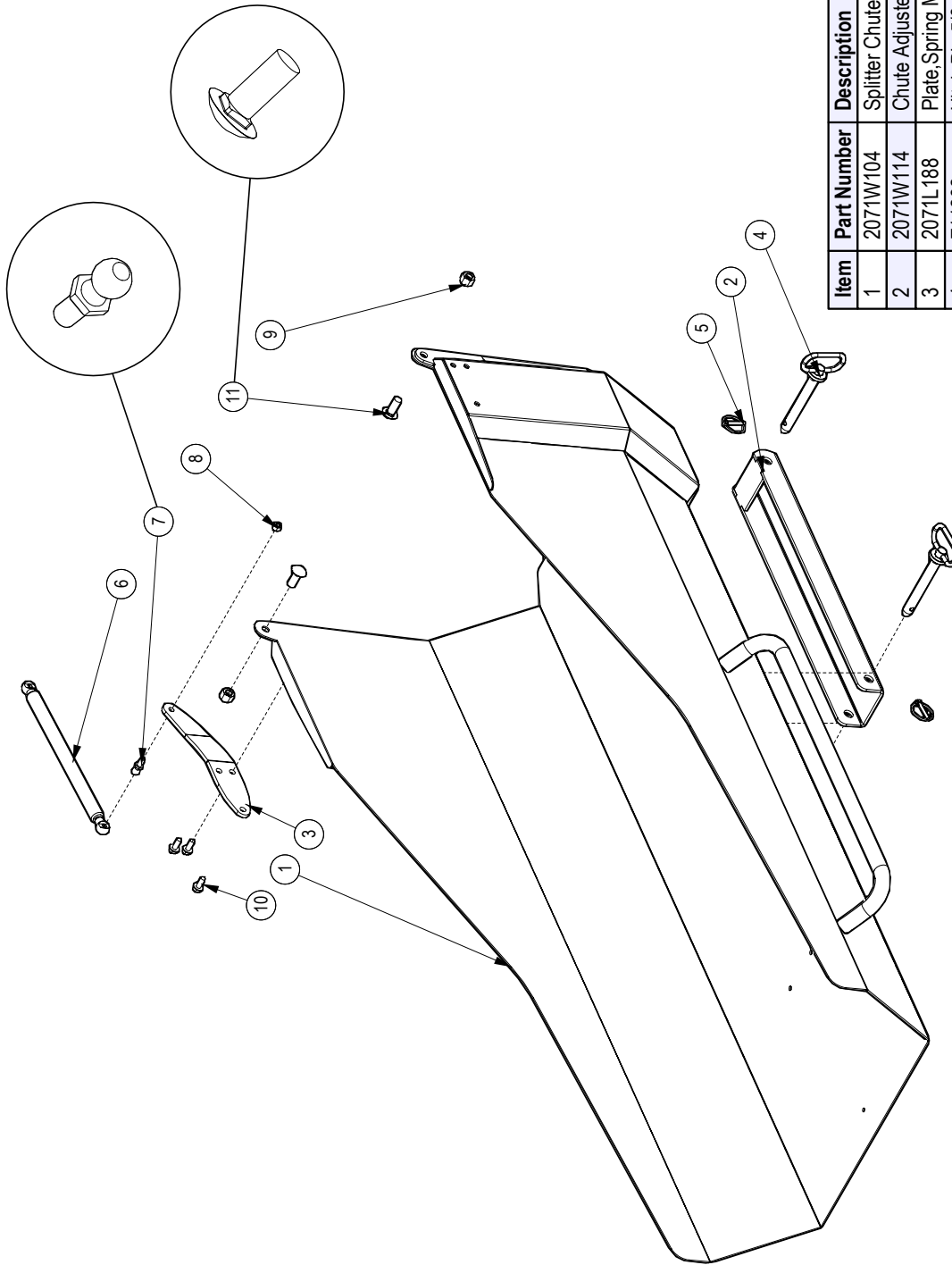

Item	Part Number	Description	Qty
1	2071W104	Splitter Chute	1
2	2071W114	Chute Adjuster	1
3	2071L188	Plate, Spring Mount	1
4	Z11232	Hitch Pin 5/8 x 4-1/4	2
5	Z12110	Latch Pin 3/16	2
6	Z34203	Gas Spring, 10mm x 8.44 Stroke	1
7	Z34204	Ball Stud 13mm x 5/16	1
8	Z72221	Hex Lock Nut, 5/16NC	1
9	Z72251	Hex Lock Nut, 1/2NC	2
10	Z76121	Flange Bolt, 5/16NC x 3/4	3
11	Z76259	Carriage Bolt, 1/2NC x 1-1/4	2

**Lead In Chute Ass'y**

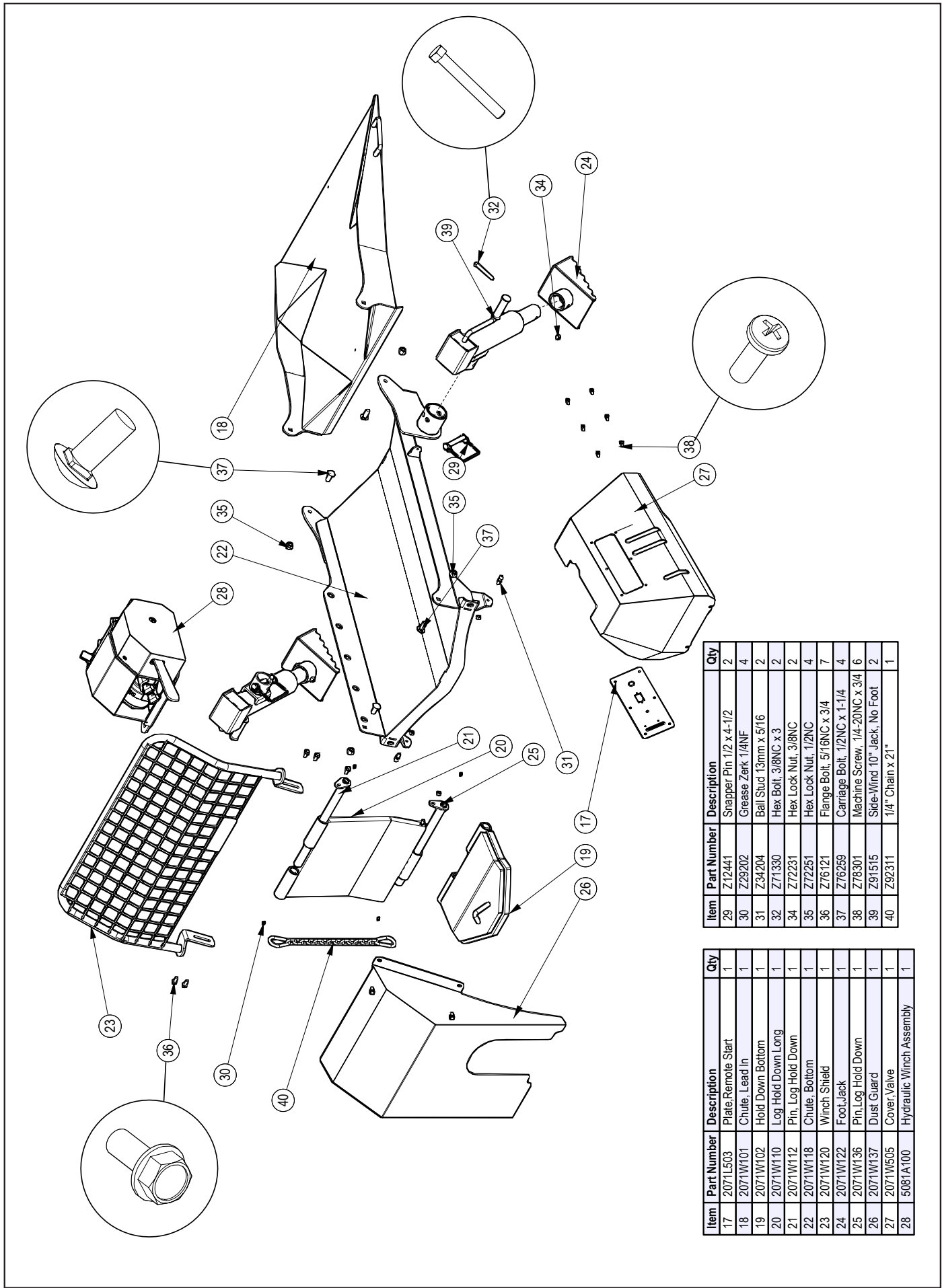

Item	Part Number	Description	Qty
29	Z12441	Snapper Pin 1/2 x 4-1/2	2
30	Z29202	Grease Zerk 1/4NF	4
31	Z34204	Ball Stud 13mm x 5f16	2
32	Z71330	Hex Bolt, 3/8NC x 3	2
34	Z72231	Hex Lock Nut, 3/8NC	2
35	Z72251	Hex Lock Nut, 1/2NC	4
36	Z76121	Flange Bolt, 5/16NC x 3/4	7
37	Z76259	Carriage Bolt, 1/2NC x 1-1/4	4
38	Z78301	Machine Screw, 1/4-20NC x 3/4	6
39	Z91515	Side-Wind 10\"/>	

Item	Part Number	Description	Qty
17	2071L503	Plate, Remote Start	1
18	2071W101	Chute, Lead In	1
19	2071W102	Hold Down Bottom	1
20	2071W110	Log Hold Down Long	1
21	2071W112	Pin, Log Hold Down	1
22	2071W118	Chute, Bottom	1
23	2071W120	Winch Shield	1
24	2071W122	Foot, Jack	1
25	2071W136	Pin, Log Hold Down	1
26	2071W137	Dust Guard	1
27	2071W505	Cover, Valve	1
28	5081A100	Hydraulic Winch Assembly	1

**Splitter Cradle Ass'y**

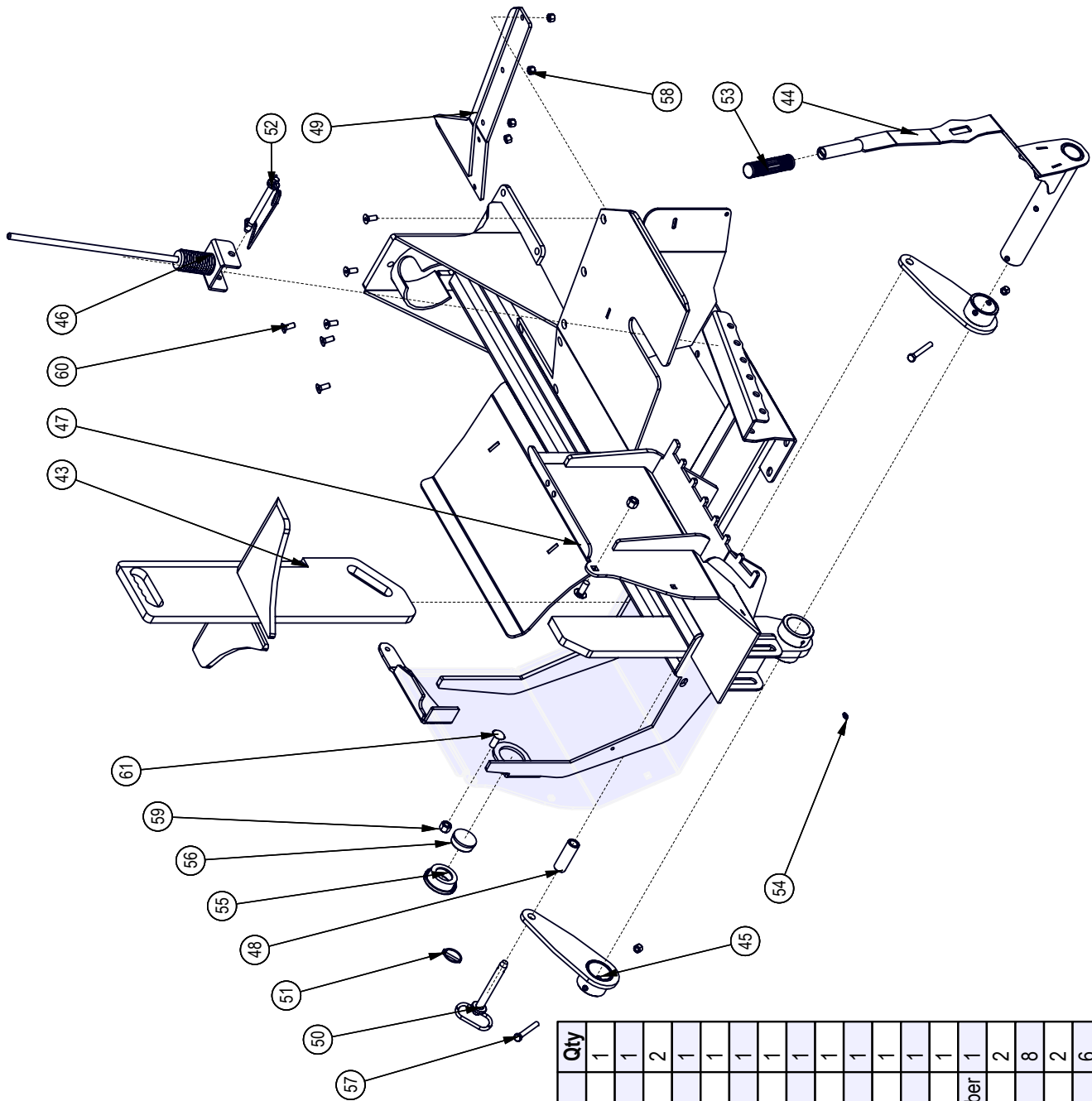

BOM ID	Part Number	Description	Qty
43	2071W103	Wedge 4 Way	1
44	2071W105	Wedge Position Handle	1
45	2071W111	Arm Wedge Lifter	2
46	2071W190	Log Stop Whip	1
47	2071W192	Weldment, Main Frame	1
48	2071M123	Roller Wedge Lift	1
49	2071S126	Edge, Log Table	1
50	Z11232	Hitch Pin 5/8 x 4-1/4	1
51	Z12110	Latch Pin 3/16	1
52	Z12441	Snapper Pin 1/2 x 4-1/2	1
53	Z19321	Grip, 1" x 5"	1
54	Z29202	Grease Zerk 1/4NF	1
55	Z61202	Round Grommet 2" Lamp	1
56	Z61205	Round Marker Lamp 2" Amber	1
57	Z71330	Hex Bolt, 3/8NC x 3	2
58	Z72231	Hex Lock Nut, 3/8NC	8
59	Z72251	Hex Lock Nut, 1/2NC	2
60	Z75233	FHCS, 3/8NC x 1	6
61	Z76259	Carriage Bolt, 1/2NC x 1-1/4	2

Log Chute Ass'y

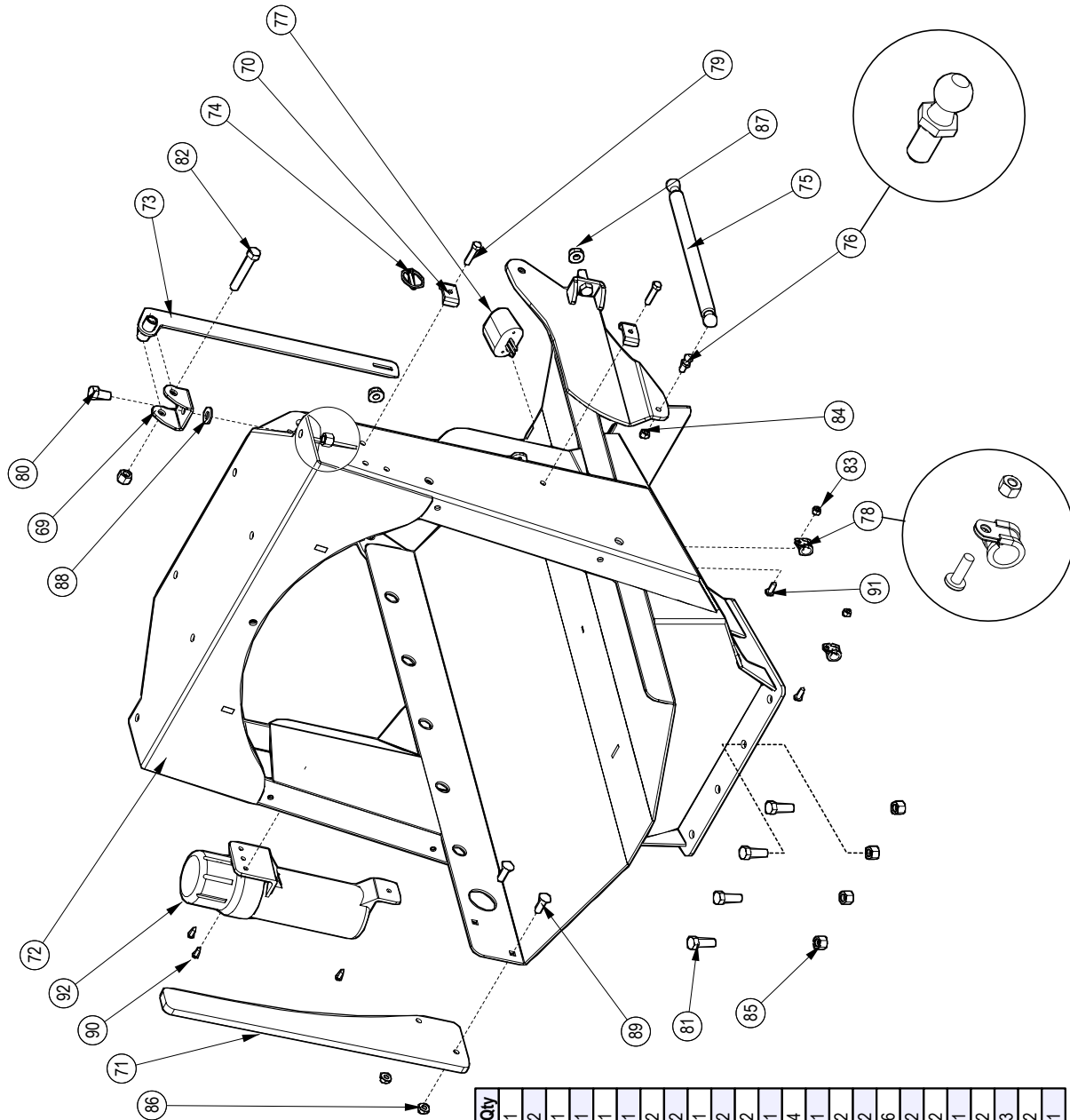

Item	Part Number	Description	Qty
69	2071L123	Clevis, Latch Mount	1
70	2071L504	Hose Clamp, 2x 1/4	2
71	2071S208	Saw Guide	1
72	2071W115	Chute, Log	1
73	2071W121	Arm, Log Chute Lock	1
74	Z12110	Latch Pin, 3/16	1
75	Z34203	Gas Spring, 10mm x 8.44 Stroke	2
76	Z34204	Ball Stud 13mm x 5/16	2
77	Z61301	License Lamp	1
78	Z62819	Rubberized Wire Clamp, 1/2"	2
79	Z71215	Hex Bolt, 5/16NC x 1-1/2	2
80	Z71510	Hex Bolt, 1/2NC x 1	1
81	Z71515	Hex Bolt, 1/2NC x 1-1/2	4
82	Z71530	Hex Bolt, 1/2NC x 3	1
83	Z72211	Hex Lock Nut, 1/4NC	2
84	Z72221	Hex Lock Nut, 5/16NC	2
85	Z72251	Hex Lock Nut, 1/2NC	6
86	Z72531	Flange Nut 3/8NC	2
87	Z72551	Flange Nut 1/2NC	2
88	Z73151	Flat Washer, 1/2	1
89	Z76232	Carriage Bolt, 3/8NC x 1-1/4	2
90	Z76712	Self-tapping Screw #10	3
91	Z78301	Machine Screw, 1/4-20NC x 3/4	2
92	Z96503	Manual Tube 3-1/2 Short	1



**Running Gear**

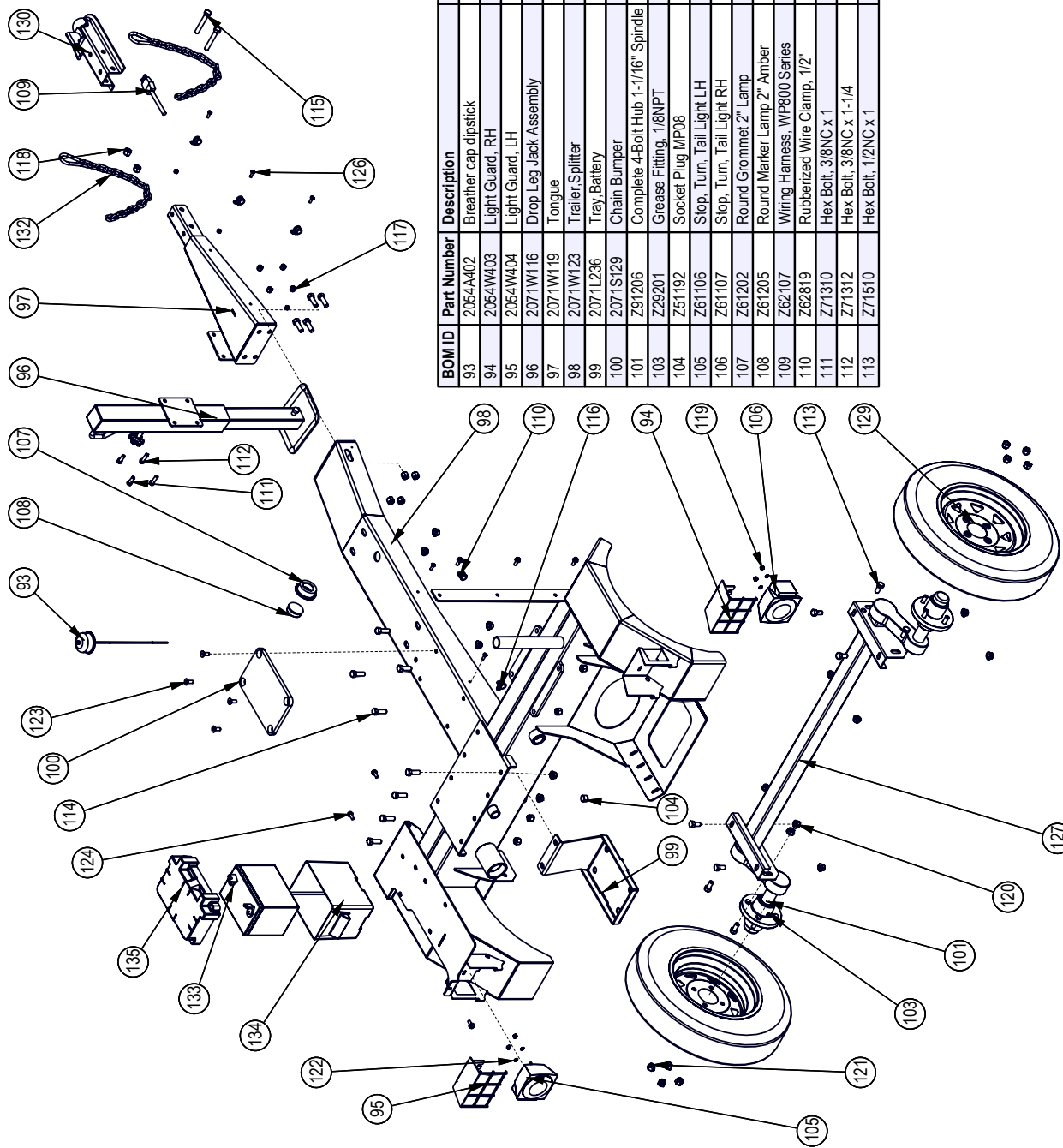

BOM ID	Part Number	Description	Qty
93	2054A402	Breather cap dipstick	1
94	2054W403	Light Guard, RH	1
95	2054W404	Light Guard, LH	1
96	2071W116	Drop Leg Jack Assembly	1
97	2071W119	Tongue	1
98	2071W123	Trailer Splitter	1
99	2071L236	Trey Battery	1
100	2071S129	Chain Bumper	1
101	Z91206	Complete 4-Bolt Hub 1-1/16" Spindle	2
103	Z29201	Grease Fitting, 1/8NPT	2
104	Z51192	Socket Plug MP08	1
105	Z61106	Stop, Turn, Tail Light LH	1
106	Z61107	Stop, Turn, Tail Light RH	1
107	Z61202	Round Grommet 2" Lamp	1
108	Z61205	Round Marker Lamp 2" Amber	1
109	Z62107	Wiring Harness, WP800 Series	1
110	Z62819	Rubberized Wire Clamp, 1/2"	5
111	Z71310	Hex Bolt, 3/8NC x 1	2
112	Z71312	Hex Bolt, 3/8NC x 1-1/4	2
113	Z71510	Hex Bolt, 1/2NC x 1	8

BOM ID	Part Number	Description	Qty
114	Z71515	Hex Bolt, 1/2NC x 1-1/2	12
115	Z71532	Hex Bolt, 1/2NC x 3-1/4	2
116	Z72211	Hex Lock Nut, 1/4NC	5
117	Z72231	Hex Lock Nut, 3/8NC	4
118	Z72251	Hex Lock Nut, 1/2NC	13
119	Z72311	Jam Nut, 1/4NC	4
120	Z72551	Flange Nut 1/2NC	14
121	Z72931	Lug Nut - 1/2NF	8
122	Z73431	Washer, Int - Ext Tooth 1/4	4
123	Z75233	FHCS, 3/8NC x 1	4
124	Z76121	Flange Bolt, 5/16NC x 3/4	6
126	Z78301	Machine Screw, 1/4-20NC x 3/4	5
127	Z91115	#9 Torflex 40x54x45deg 2200#	1
129	Z91322	5-30-12 LRC USA Trail E-Marked	2
130	Z91614	2" Hitch Coupler	1
132	Z92303	Safety Chain 1/4 x 2'	2
133	Z93204	325 CCA Battery	1
134	Z93401-1	U1 Battery Box Base	1
135	Z93401-2	U1 Battery Box Lid	1

Note: Axle comes complete with hubs: see Hub Assembly Detail.

**Hub Assembly Detail**

Item	Part Number	Description	Qty
123	Z12322	2" x 3/16" Split Pin	1
124	Z23202	L44649 Cone, L44610 Cup	2
125	Z28302	Double Lip Seal 1-1/16 Spindle	1
126	Z29201	Grease Fitting, 1/8NPT	1
127	Z72930	Lug Nut 1/2NF	4
128	Z91201	1000# 4-Bolt Hub	1
129	Z91801	Dust Cap 1.98 Bore	1
130	Z72691	1" Castle Nut	1

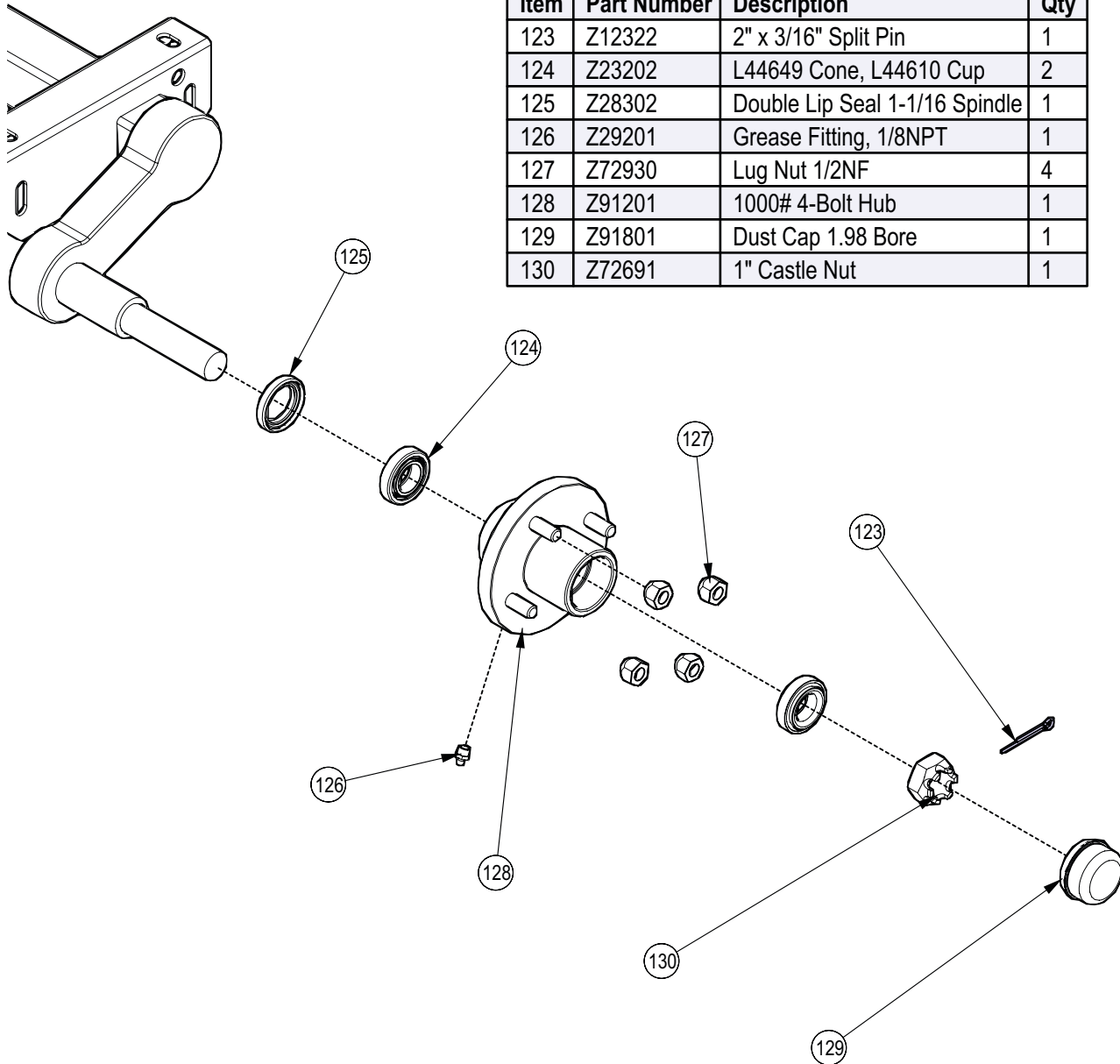

**Engine & Pump Ass'y**

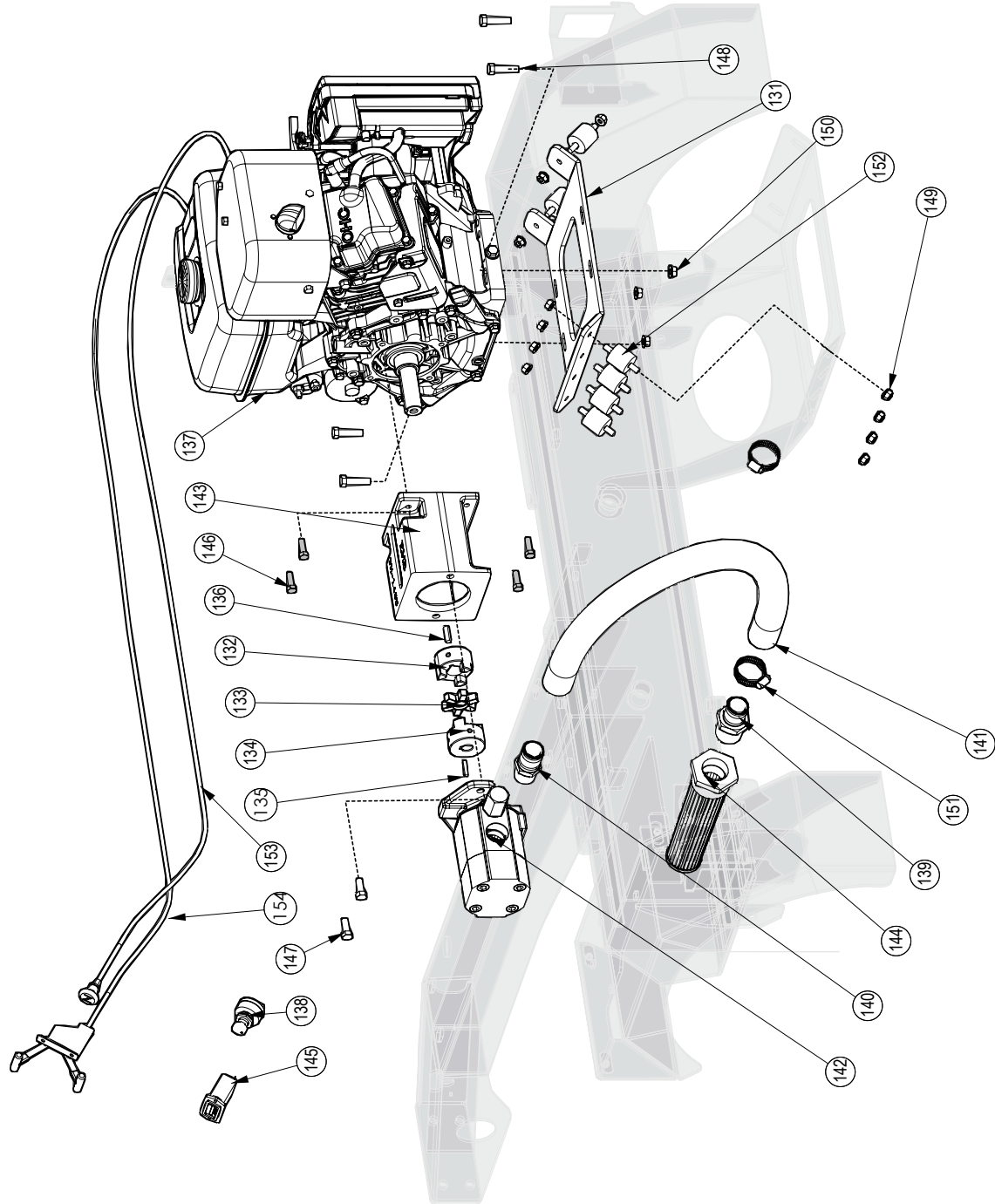

Item	Part Number	Description	Qty
131	2071L185	Plate, Engine Mount	1
132	Z46404	Shaft Coupler L095 x 1	1
133	Z46405	Coupler Spider L095	1
134	Z46419	Shaft Coupler L095 x 5/8	1
135	Z46522	Key, 3/16 x 3/16 x 1	1
136	Z46533	Key, 1/4 x 1/4 x 1	1
137	Z47712	Subaru EX400DP 14hp Engine	1
138	Z47906	Keyswitch for Subaru EX400	1
139	Z51185	Straight MP x HB 2020	1
140	Z51186	Straight MP x HB 1620	1
141	Z52408	1-1/4" Suction Hose x 30"	1
142	Z53206	Two-Stage Pump, 22gpm	1
143	Z53806	Pump Mount, PM14SU	1
144	Z55102	Tank Strainer, 2" NPT	1
145	Z64611	Hour Meter, E-Mech DC	1
146	Z71274	Hex Bolt, 5/16NF x 1	4
147	Z71310	Hex Bolt, 3/8NC x 1	2
148	Z71315	Hex Bolt, 3/8NC x 1-1/2	4
149	Z72521	Flange Nut, 5/16NC	11
150	Z72531	Flange Nut, 3/8NC	3
151	Z79404	Hose Clamp, #24	2
152	Z79931	Rubber Mount	6
153	Z92115	Remote Choke Cable 68"	1
154	Z92116	Remote Throttle Cable 66"	1

**Hydraulic Lines**

Item	Part Number	Description	Qty
159	Z51293	Tee FP x FP x FP 121212	1
160	Z51331	Elbow 90 MP x FPX 0808	2
161	Z51333	Elbow 90 MP x FPX 1612	1
162	Z51335	Elbow 90 MP x FPX 1212	2
163	Z51389	Elbow 90 ORB x FPX 1212	2
164	Z51613	Straight ORB x MP 1212	2
165	Z52123	1/4 Hose, #6FJIC x 1/2NPT x 45"	2
166	Z52409	3/4 Hose, 3/4NPT x 3/4NPT x 36"	1
167	Z52411	3/4 Hose 3/4NPT x 3/4NPT x 14"	1
168	Z52413	3/4 Hose 3/4NPT x 3/4NPT x 18"	1
169	Z55303	Oil Filter - 1" - Particulate	1
170	Z55304	Filter Cap, FP16 x FP16	1

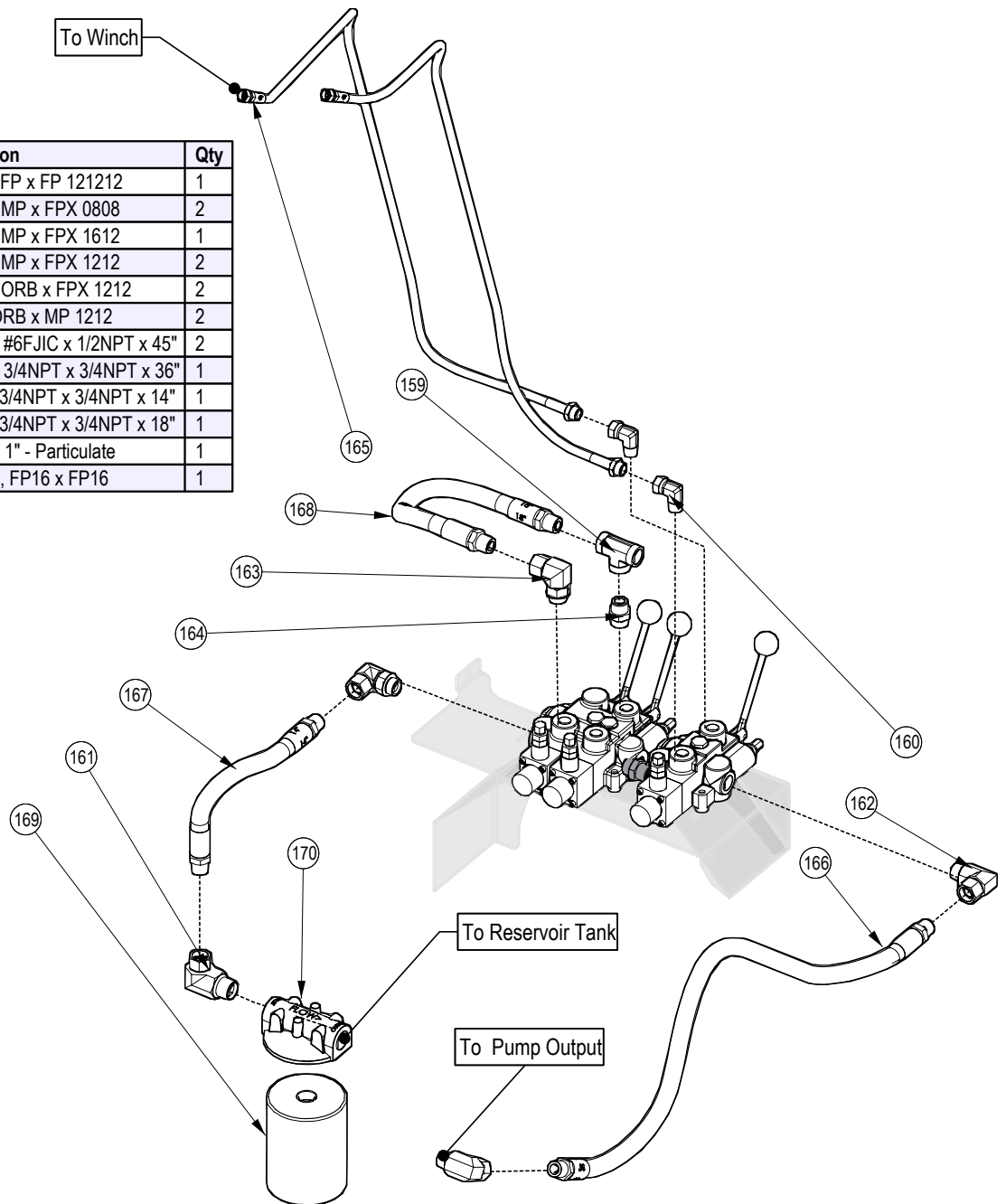

**Hydraulic Splitter Ass'y**

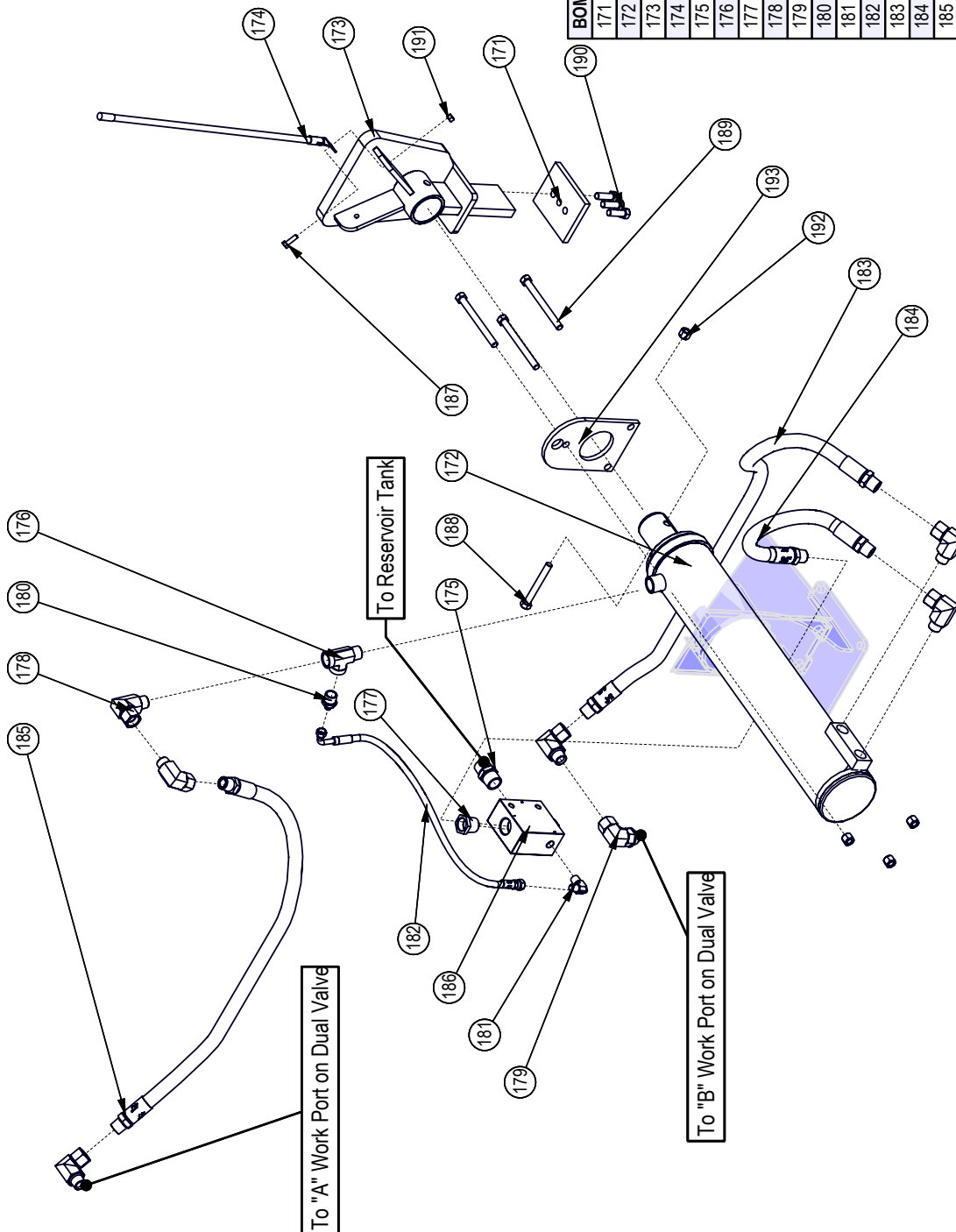

BOM ID	Part Number	Description	Qty
171	2055S17	Cap, Push Block	1
172	2071C101	Cylinder, 4-1/2 x 24 x 2-1/2	1
173	2071W109	Weldment, Hvy Push Block	1
174	Z19908	Whip 1/2 x 24	1
175	Z51125	Straight MP x MP 1616	1
176	Z51171	Street Tee MP12 x FP12 x FP12	1
177	Z51225	Reducer MP x FP 1612	1
178	Z51335	Elbow 90 MP x FPX 1212	6
179	Z51389	Elbow 90 ORB x FPX 1212	1
180	Z51446	Straight MJ x MP 0612	1
181	Z51452	#6JIC x 3/8NPT 90 Elbow	1
182	Z52122	1/4 Hose, #6FJIC x #6FJIC 90 x 20"	1
183	Z52410	3/4 Hose, MP12 x MP12 x 54"	1
184	Z52418	3/4 Hose, MP12 x MP12 x 26"	1
185	Z52420	3/4 Hose, 3/4NPT x 3/4NPT x 40"	1
186	Z56405	Dump Valve	1
187	Z71210	Hex Bolt, 5/16NC x 1	1
188	Z71540	Hex Bolt, 1/2NC x 4	1
189	Z71555	Hex Bolt, 1/2NC x 5-1/2	3
190	Z71576G8	Hex Bolt, 1/2NF x 1-1/2 G8	3
191	Z72221	Hex Lock Nut, 5/16NC	1
192	Z72251	Hex Lock Nut, 1/2NC	4
193	2071L215	Plate, Cylinder Retaining	1

Hydraulic Valves

Item	Part Number	Description	Qty
194	660150004	Handle Kit (Prince)	1
195	Z56213	Dual Valve, Auto-cycle	1
196	Z56214	Single Spring Center Valve	1
197	Z71320	Hex Bolt, 3/8NC x 2	6
198	Z72231	Hex Lock Nut, 3/8NC	6
199	Z51613	Straight ORB x MP 1212	1

Note: Replacement valves come complete with handle.

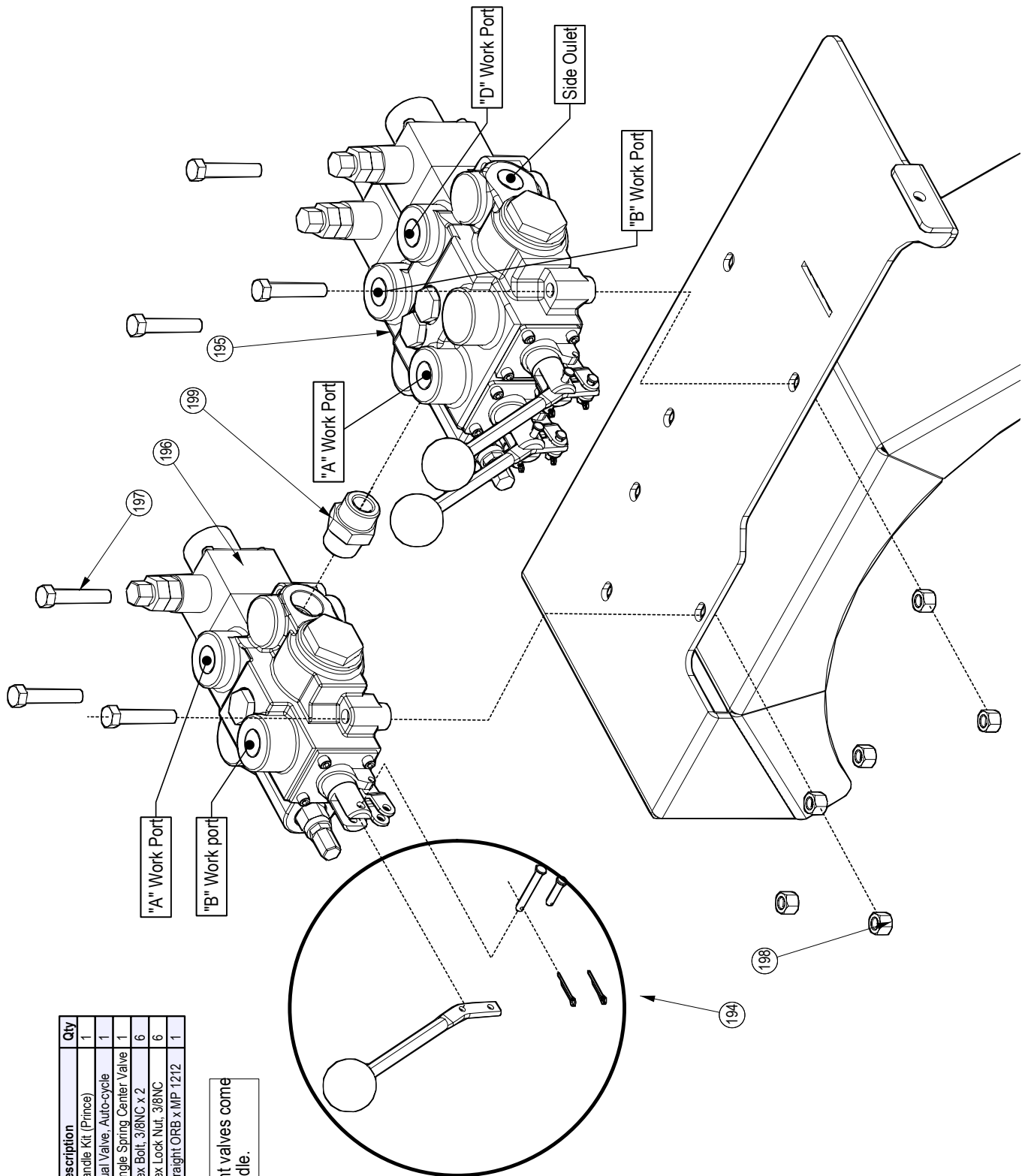

**Hydraulic Cylinder**

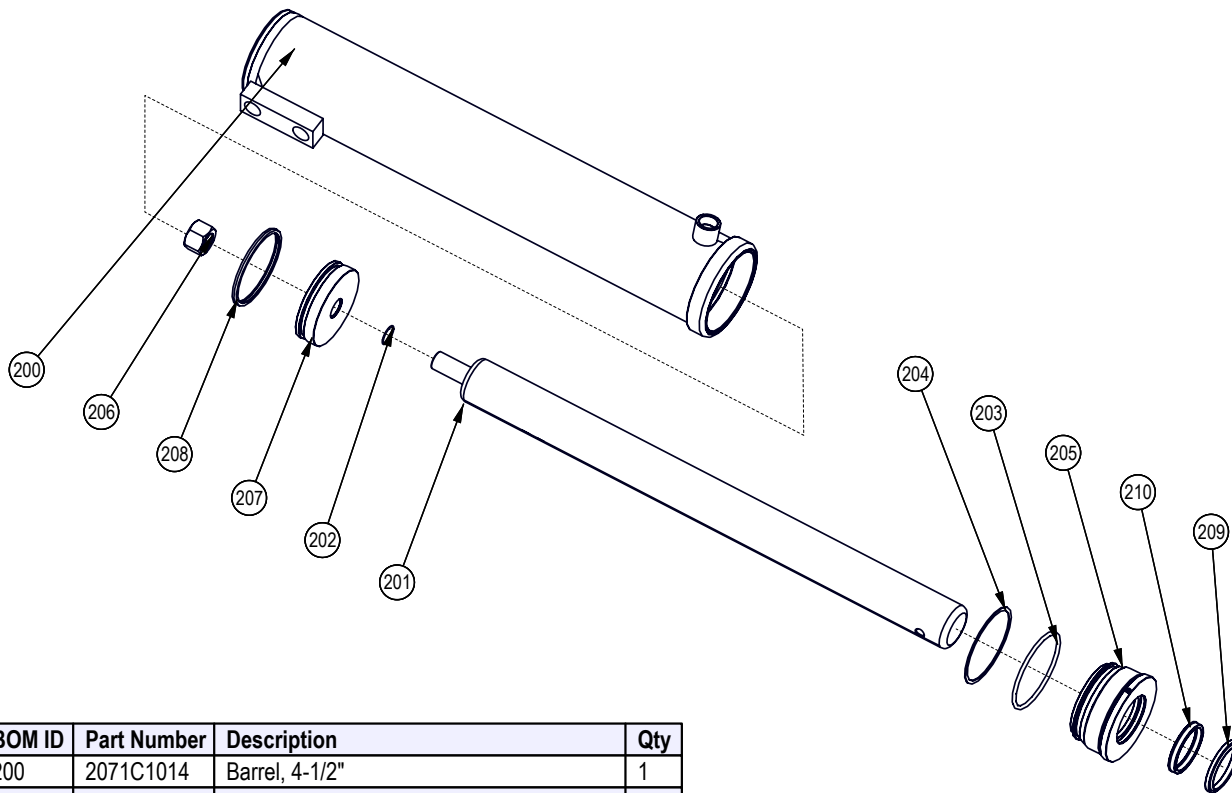

BOM ID	Part Number	Description	Qty
200	2071C1014	Barrel, 4-1/2"	1
201	2071C1012	Rod, 2-1/2x 1	1
202	568-018	Piston To Rod Seal O-Ring 1"	1
203	568-346	4-1/2"OD X 1/8" CROSS SECTION O-RING	1
204	575-346	4-1/2" Back-Up Ring	1
205	G450-250S	4-1/2" X 2-1/2" GLAND	1
206	Z72292G8	Hex Lock Nut 1NF Grade 8	1
207	P100-450SP	4-1/2" BORE PISTON	1
208	PSC-346	4-1/2" Double Acting Piston Seal	1
209	ST-250	2-1/2" Rod Wiper	1
210	UI8-250-37B	2-1/2" X 2-7/8" X 3/8" U-CUP	1

VIEW SHOWS PROPER SEAL ORIENTATION

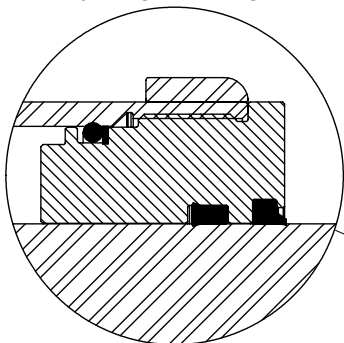

**Hydraulic Cylinder Seal Kit #SLK-4525**

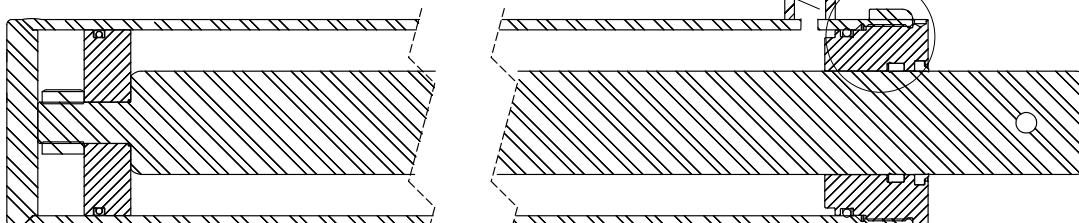



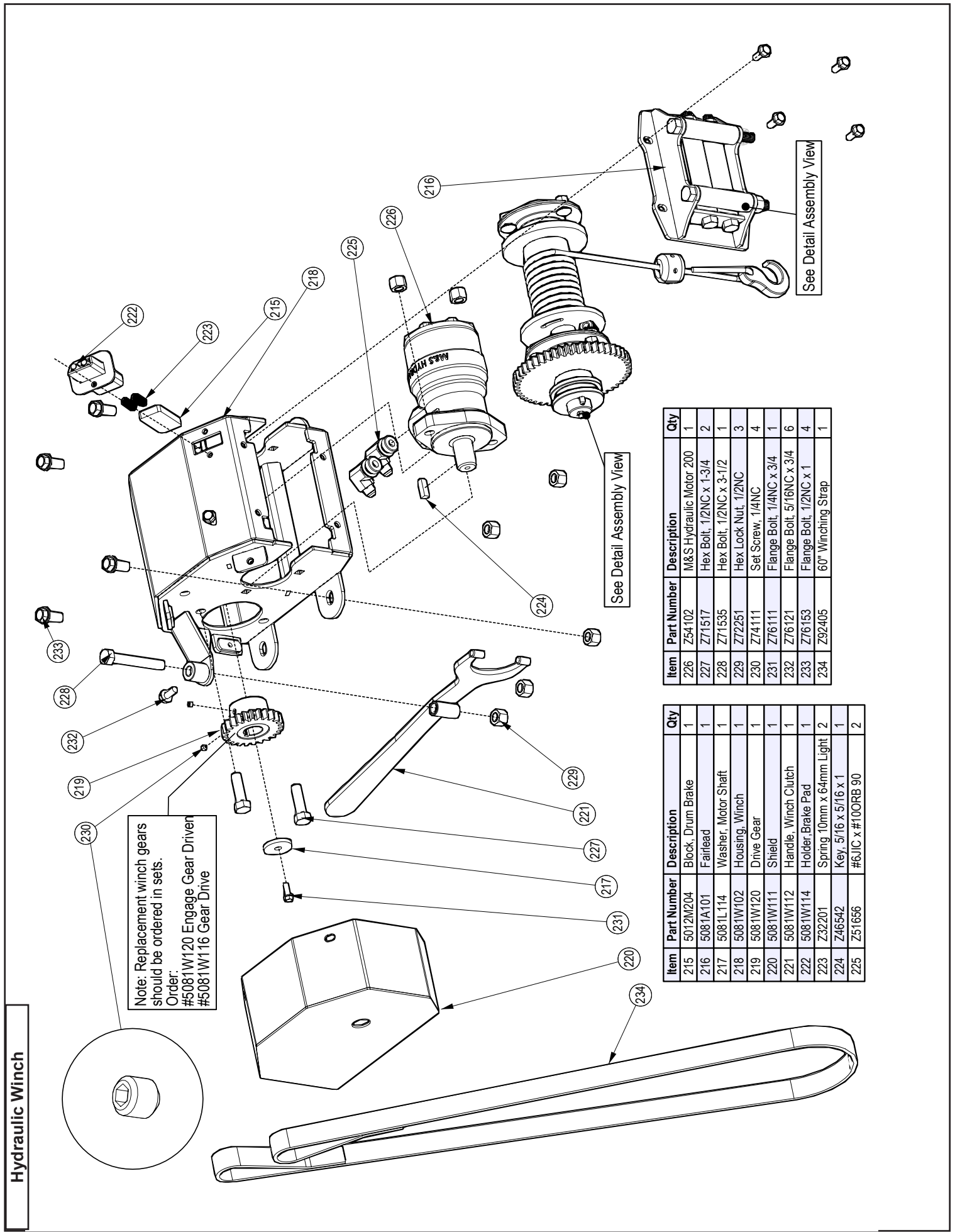

**Hydraulic Winch**

Note: Replacement winch gears should be ordered in sets.  
 Order:  
 #5081W120 Engage Gear Drive  
 #5081W116 Gear Drive

Item	Part Number	Description	Qty
	Z64-102	M&S Hydraulic Motor 200	1
226	Z71517	Hex Bolt, 1/2NC x 1-3/4	2
227	Z71535	Hex Bolt, 1/2NC x 3-1/2	1
228	Z72251	Hex Lock Nut, 1/2NC	3
229	Z74111	Set Screw, 1/4NC	4
230	Z76111	Flange Bolt, 1/4NC x 3/4	1
231	Z76121	Flange Bolt, 5/16NC x 3/4	6
232	Z76153	Flange Bolt, 1/2NC x 1	4
233	Z92405	60" Winching Strap	1

Item	Part Number	Description	Qty
	5012M204	Block, Drum Brake	1
215	5081A101	Fairlead	1
216	5081L114	Washer, Motor Shaft	1
217	5081W102	Housing, Winch	1
218	5081W120	Drive Gear	1
219	5081W111	Shield	1
220	5081W112	Handle, Winch Clutch	1
221	5081W114	Holder, Brake Pad	1
222	Z32201	Spring 10mm x 64mm Light	2
223	Z46542	Key, 5/16 x 5/16 x 1	1
224	Z51656	#6JIC x #10ORB 90	2



**Winch Drum Detail**

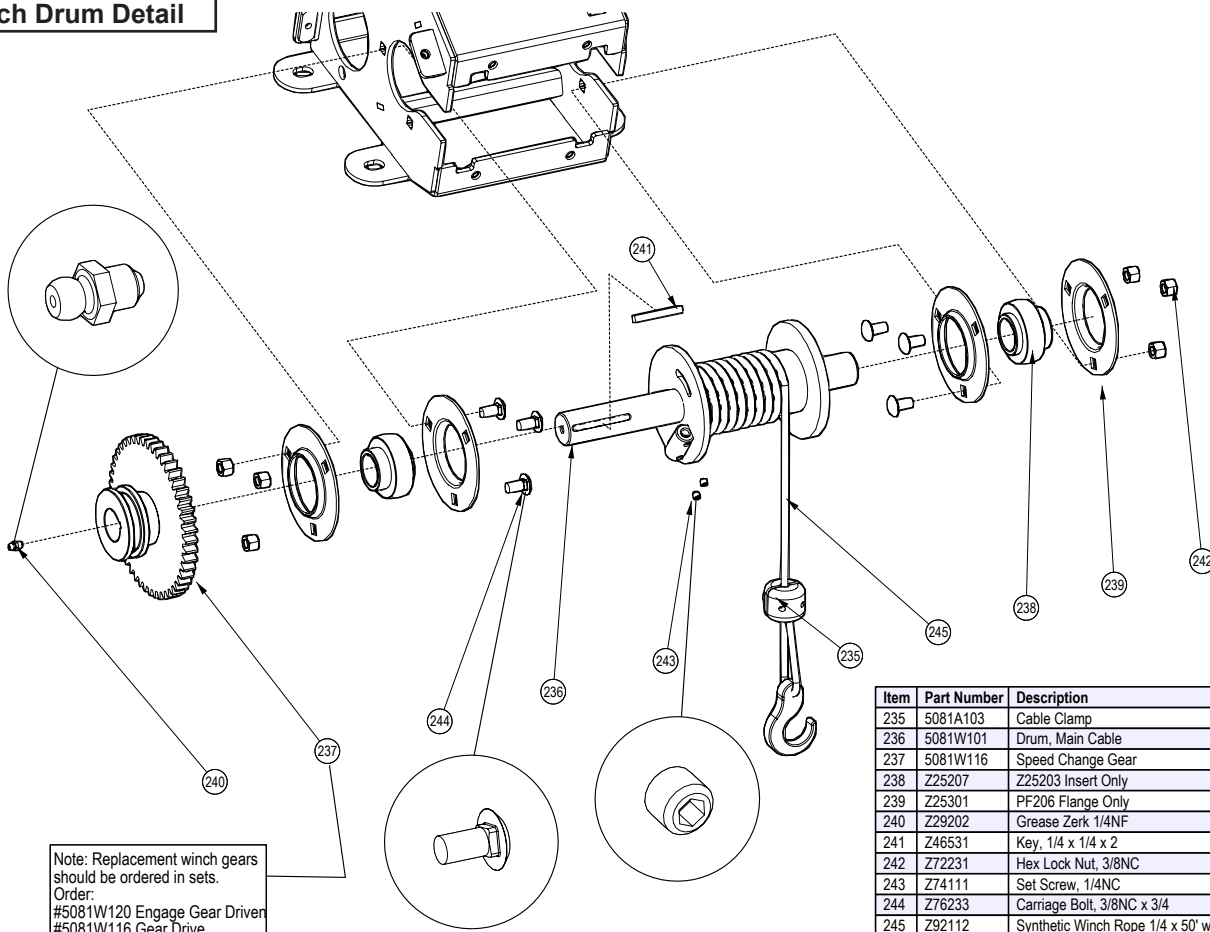

Note: Replacement winch gears should be ordered in sets.  
Order:  
#5081W120 Engage Gear Drive  
#5081W116 Gear Drive

Item	Part Number	Description	Qty
235	5081A103	Cable Clamp	1
236	5081W101	Drum, Main Cable	1
237	5081W116	Speed Change Gear	1
238	Z25207	Z25203 Insert Only	2
239	Z25301	PF206 Flange Only	4
240	Z29202	Grease Zerk 1/4NF	1
241	Z46531	Key, 1/4 x 1/4 x 2	1
242	Z72231	Hex Lock Nut, 3/8NC	6
243	Z74111	Set Screw, 1/4NC	2
244	Z76233	Carriage Bolt, 3/8NC x 3/4	6
245	Z92112	Synthetic Winch Rope 1/4 x 50' with Hook	1

**Winch Fairlead Detail**

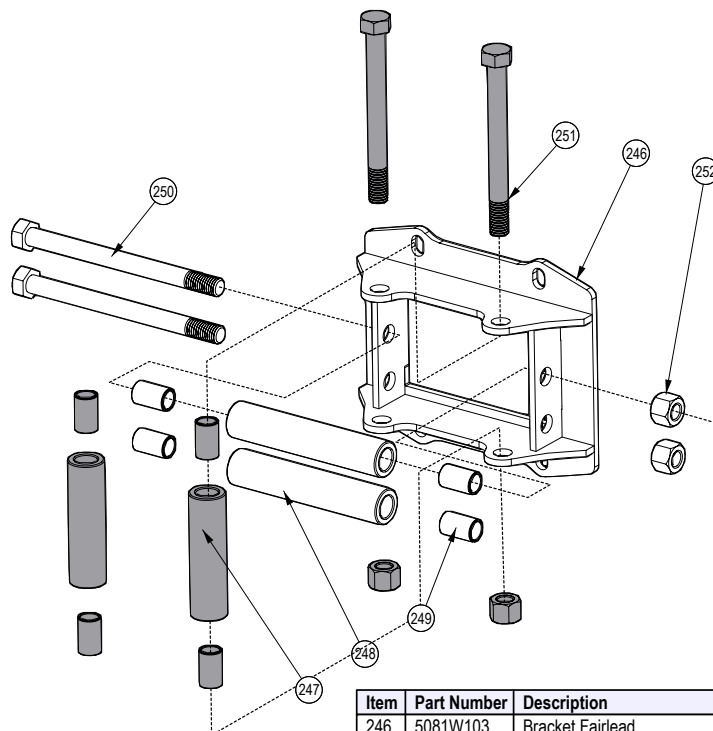

Item	Part Number	Description	Qty
246	5081W103	Bracket, Fairlead	1
247	5081M109	Bushing, Fairlead Side	2
248	5081M111	Bushing, Fairlead Top	2
249	Z27103	Fiberglide Bearing 1/2" x 1"	8
250	Z71566	Hex Bolt, 1/2NC x 6-1/4, 5-1/4 Shank	2
251	Z71567	Hex Bolt, 1/2NC x 5, 4" Shank	2
252	Z72251	Hex Lock Nut, 1/2NC	4

Labels

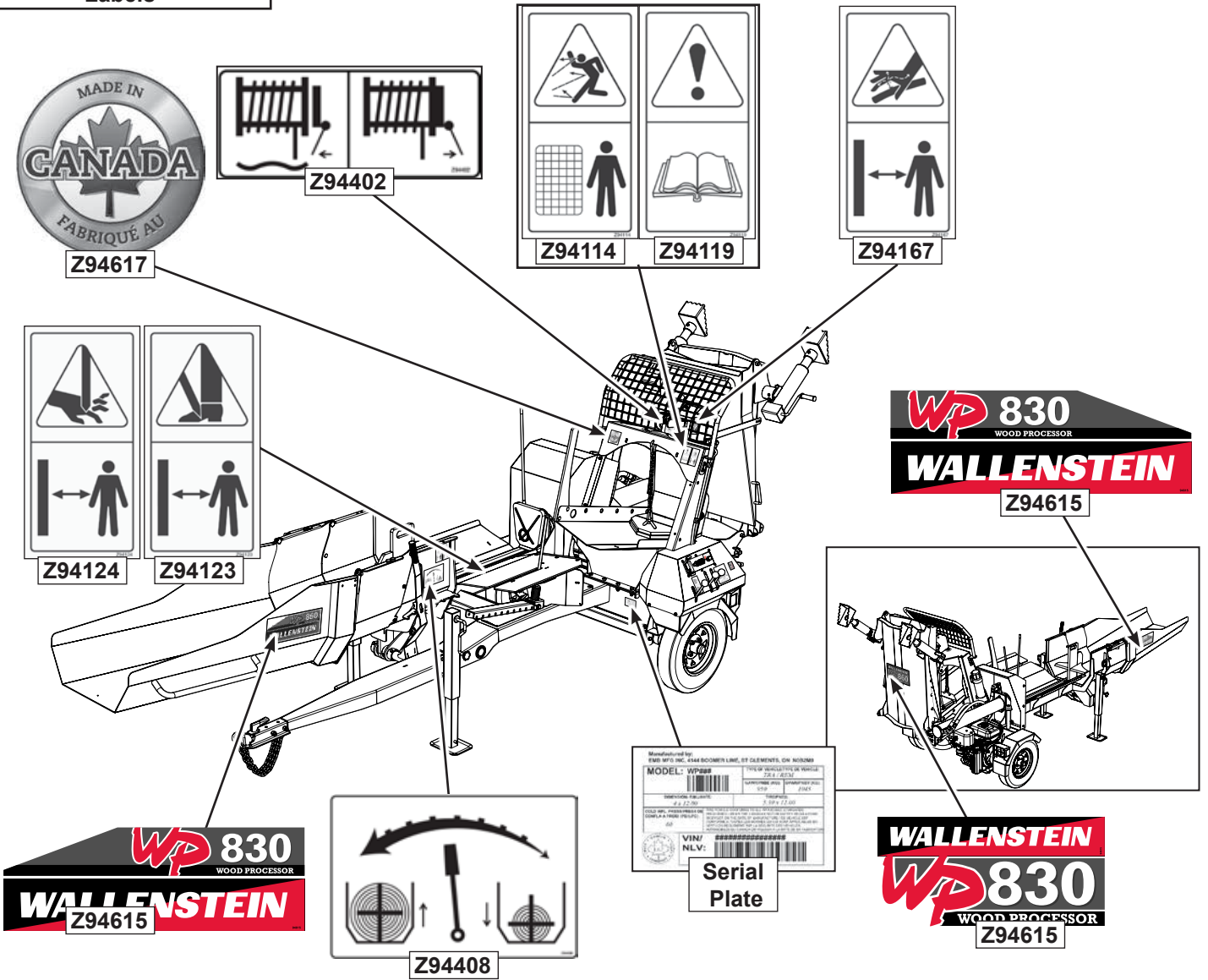

Control Panel Labels

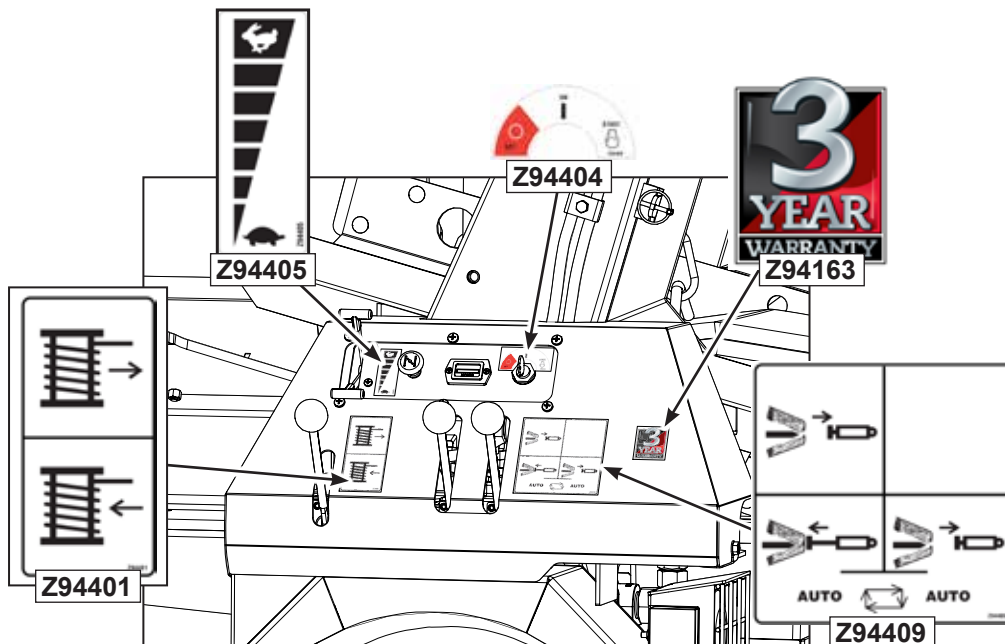





**Accessories**

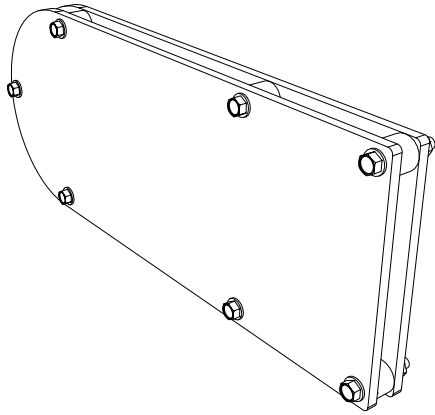

#2089A570 NYLON CHAINSAW HOLSTER

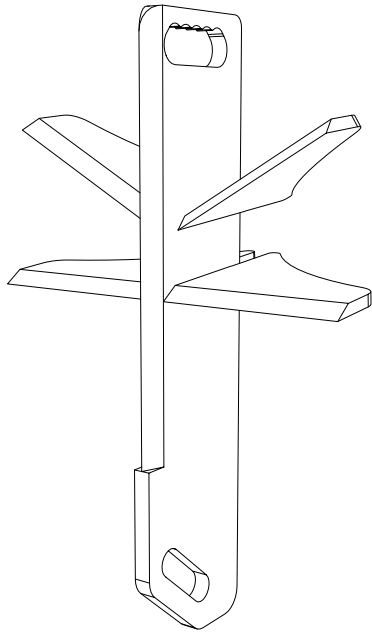

#2089W571 6-WAY WEDGE

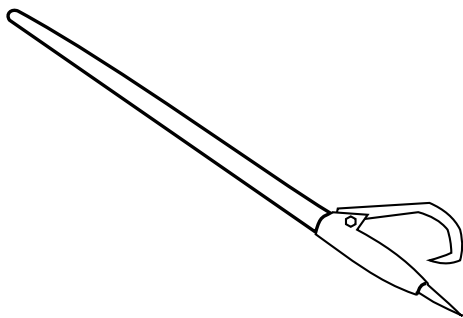

#299001 48" LOG PEAVEY

**Manual**

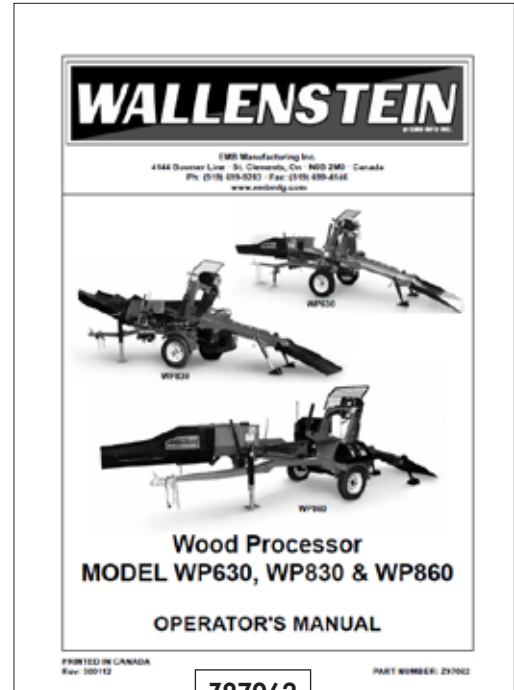

Available as a download at  
[www.embmfg.com](http://www.embmfg.com)

