

PARTS MANUAL

Serial Number 2E9US1113JS540001 & up

WXR545PL TRAILER WOOD SPLITTER

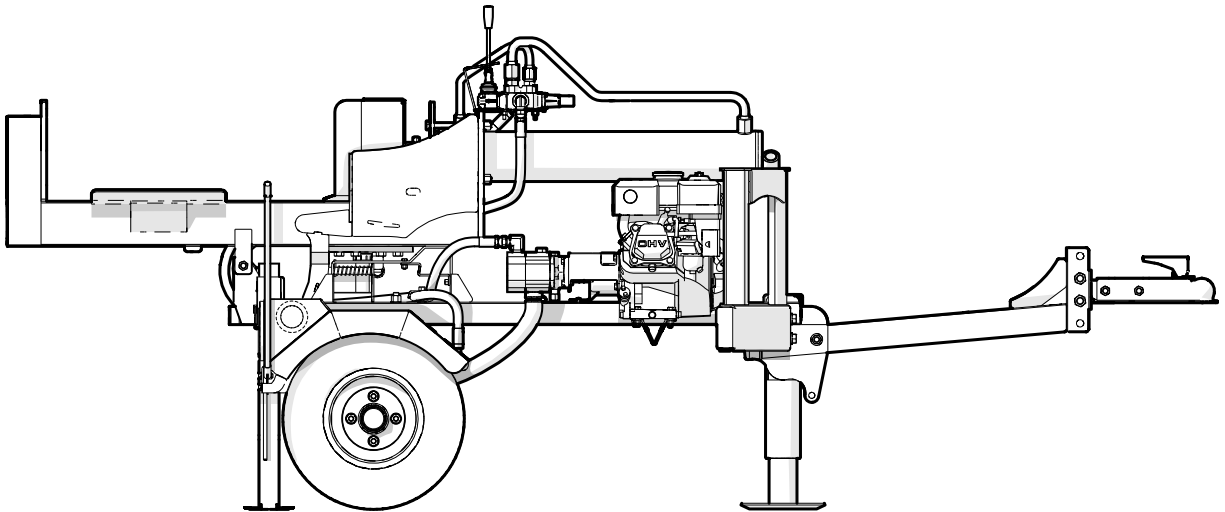

Foreword

This Wallenstein parts manual is prepared to assist customers in ordering quality OEM replacement parts.

Regular maintenance combined with replacing old, worn or broken parts with the correct OEM parts is essential in prolonging the life of your Wallenstein product. Refer to this manual to identify replacement parts.

To order parts, contact your Wallenstein dealer or distributor. Have the product model and serial number handy.

If your dealer is no longer available, please go to our website: <http://www.wallensteinequipment.com> and click on the [Dealer Locator](#) to find the nearest dealer.

All information contained in this parts manual is current as per the revision date at the bottom of the page. Wallenstein reserves the right to change product specifications at any time without notice.

If your product specifications differ from those contained in this manual, contact Wallenstein for current information.

Reproduction of information in this parts manual is prohibited without prior written permission from Wallenstein Equipment Inc.

Wallenstein Equipment Inc. • © 2018

WARNING!

Refer to the operators manual for safe operation and maintenance.

Maintenance should be performed by trained personnel only.

Serial Number Location

Always provide the model and serial number of your Wallenstein product when ordering parts or requesting service or other information. This information is found on the product information plate as shown below.

Record product information for future reference.

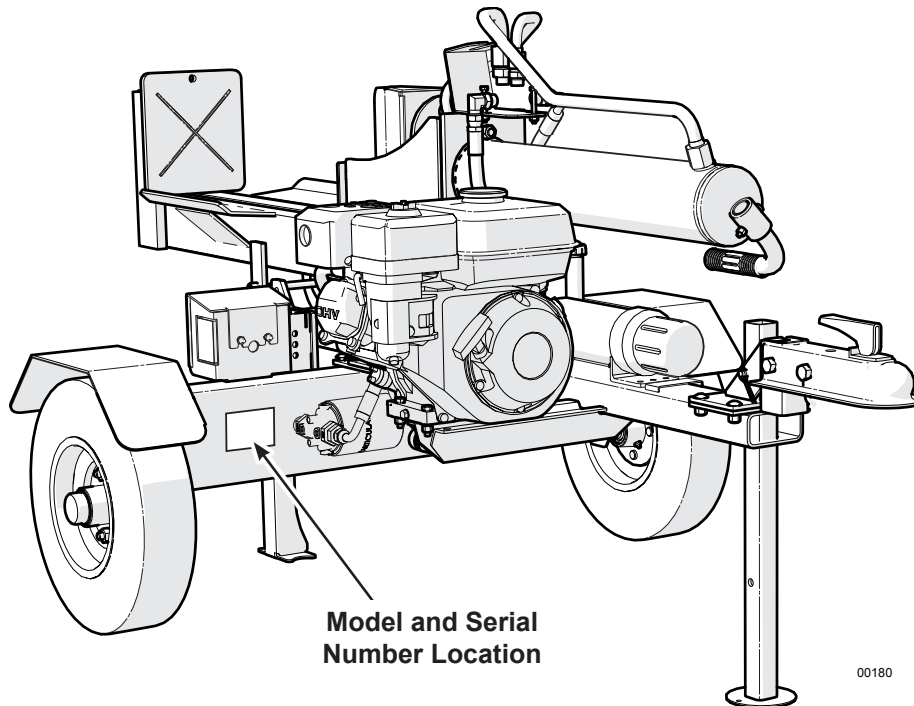

00180

Contents

Main Frame Assembly	4
Tank and Axle Assembly	5
Tongue and Hitch Assembly	6
Engine and Hydraulic Pump Detail	7
Splitter Bed Assembly	8
Hitch Assembly	9
Hub Detail	10
Cylinder Detail	11
Hydraulic Plumbing Diagram	12
Wiring Harness and Lights	13
Decal Layout.....	14
Accessories	15
Common Bolt Torque Values	16
Hydraulic Fitting Torque.....	17
Wheel Lug Torque	17

Main Frame Assembly

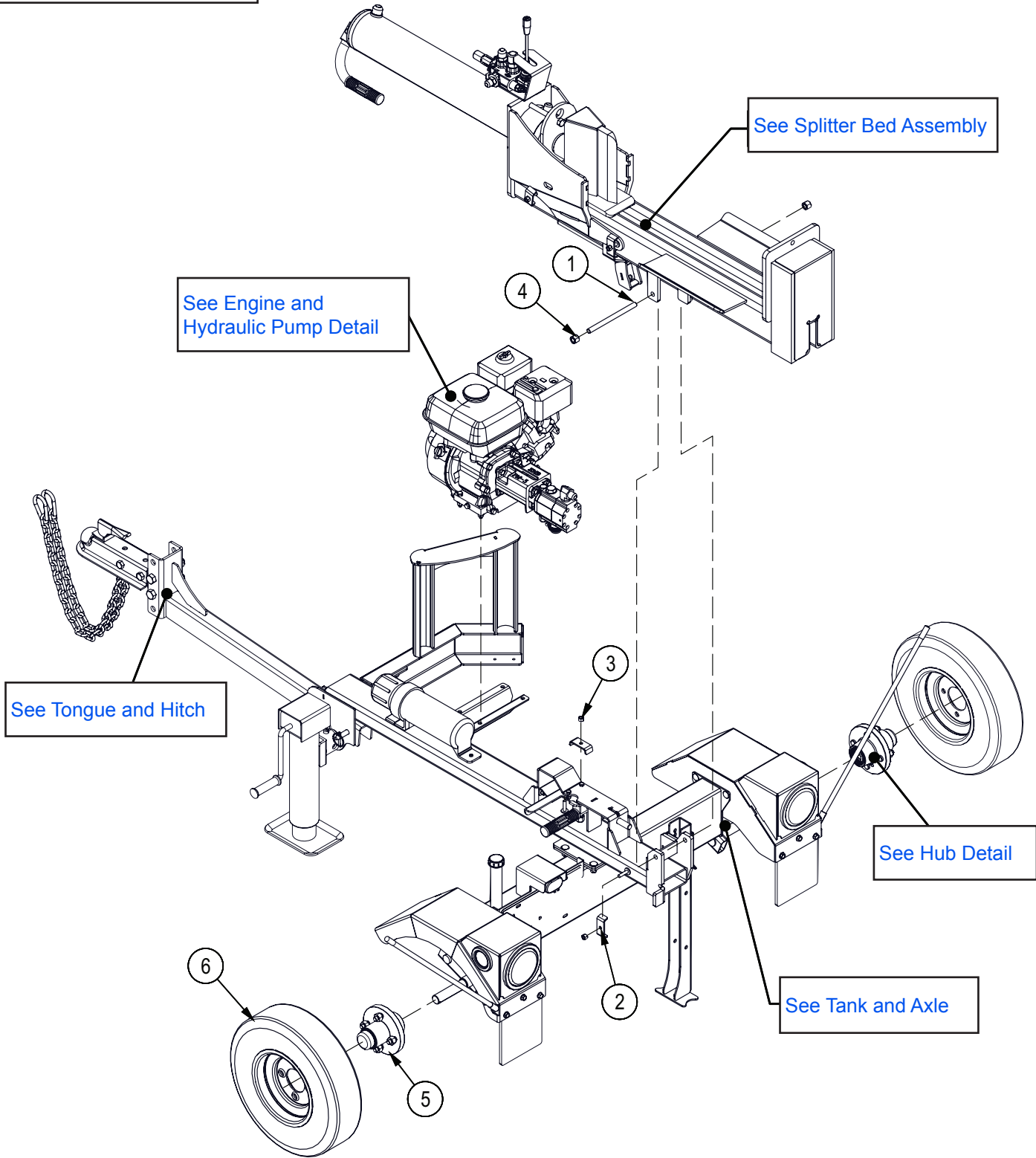

Item No.	Part No.	Description	Qty
1	2016M602	Pin, Pivot Threaded	1
2	2054L412	Clamp, Two Hose	2
3	Z72221	Hex Lock Nut, 5/16NC	2
4	Z72251	Hex Lock Nut, 1/2NC	2
5	Z91202	Idle Hub Assy, 1000lbs x 4on4" x 1"	2
6	Z91301	4.80-8 LRB SportTrail 4on4"	2

Tank and Axle Assembly

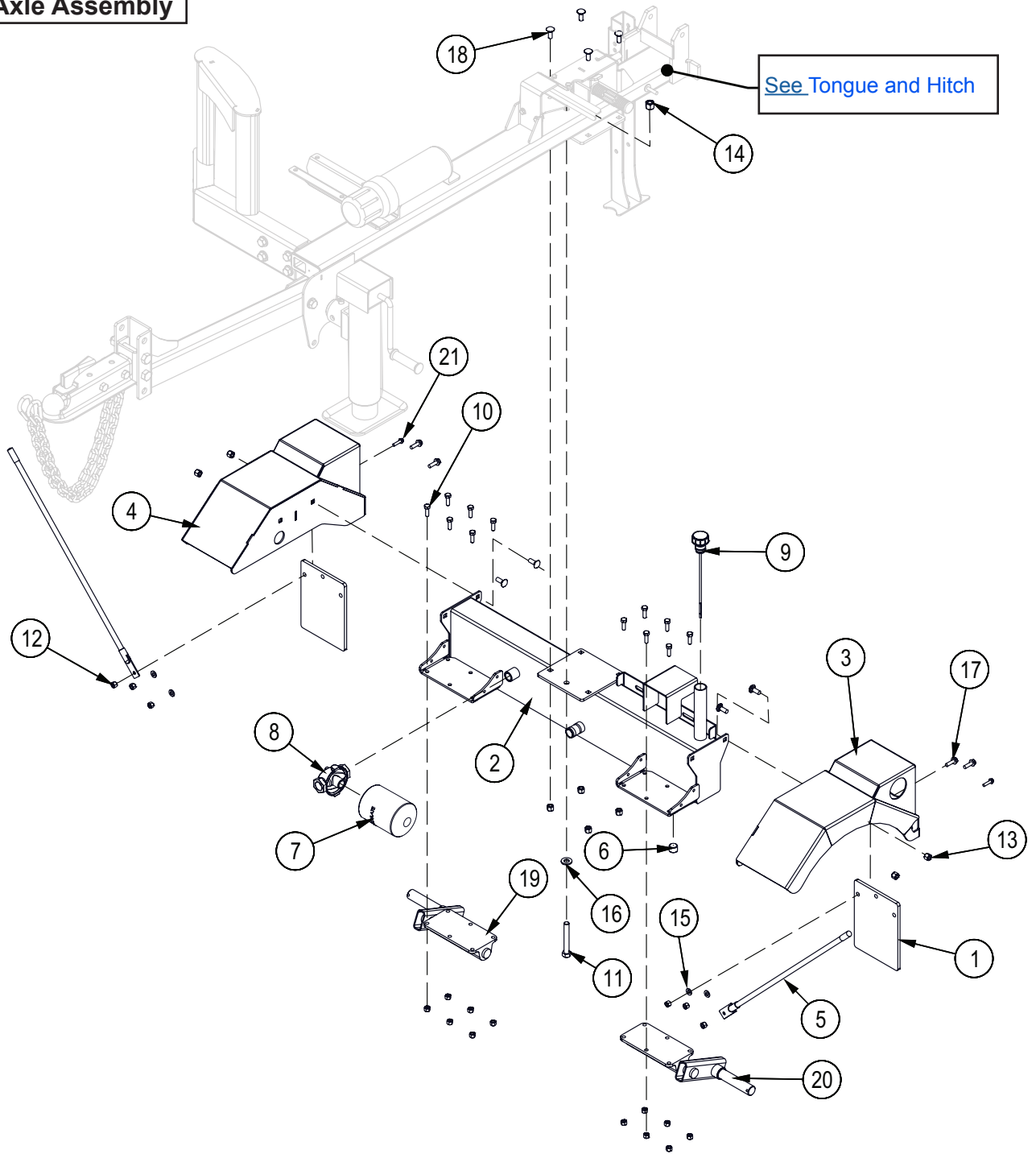

Item No.	Part No.	Description	Qty
1	2054S655	Rain Flap	2
2	2073W522	WXR Pro Tank - Axle	1
3	2073W525	WXR Pro Fender, LH	1
4	2073W525H	WXR Pro Fender, RH	1
5	Z19908	Blade Guide, 1/2" x 24"	2
6	Z51192	Socket Plug, MP 08	1
7	Z55301	Particulate Filter, FP12	1
8	Z55302	Filter Cap, MP12 x FP12	1
9	Z55404	Vented Plug Dipstick x 9"	1
10	Z71210	Hex Bolt, 5/16NC x 1"	12
11	Z71535	Hex Bolt, 1/2NC x 3-1/2"	1

Item No.	Part No.	Description	Qty
12	Z72221	Hex Lock Nut, 5/16NC	18
13	Z72231	Hex Lock Nut, 3/8NC	8
14	Z72251	Hex Lock Nut, 1/2NC	1
15	Z73122	SAE Washer, 5/16"	4
16	Z73151	SAE Washer, 1/2"	1
17	Z76134	Flange Bolt, 3/8NC x 1"	4
18	Z76231	Carriage Bolt, 3/8NC x 1"	8
19	Z91111	RH Stub Flex Axle, 935lbs	1
20	Z91112	LH Stub Flex Axle, 935lbs	1
21	Z76114	Flange Bolt, 1/4NC x 1"	2

Tongue and Hitch Assembly

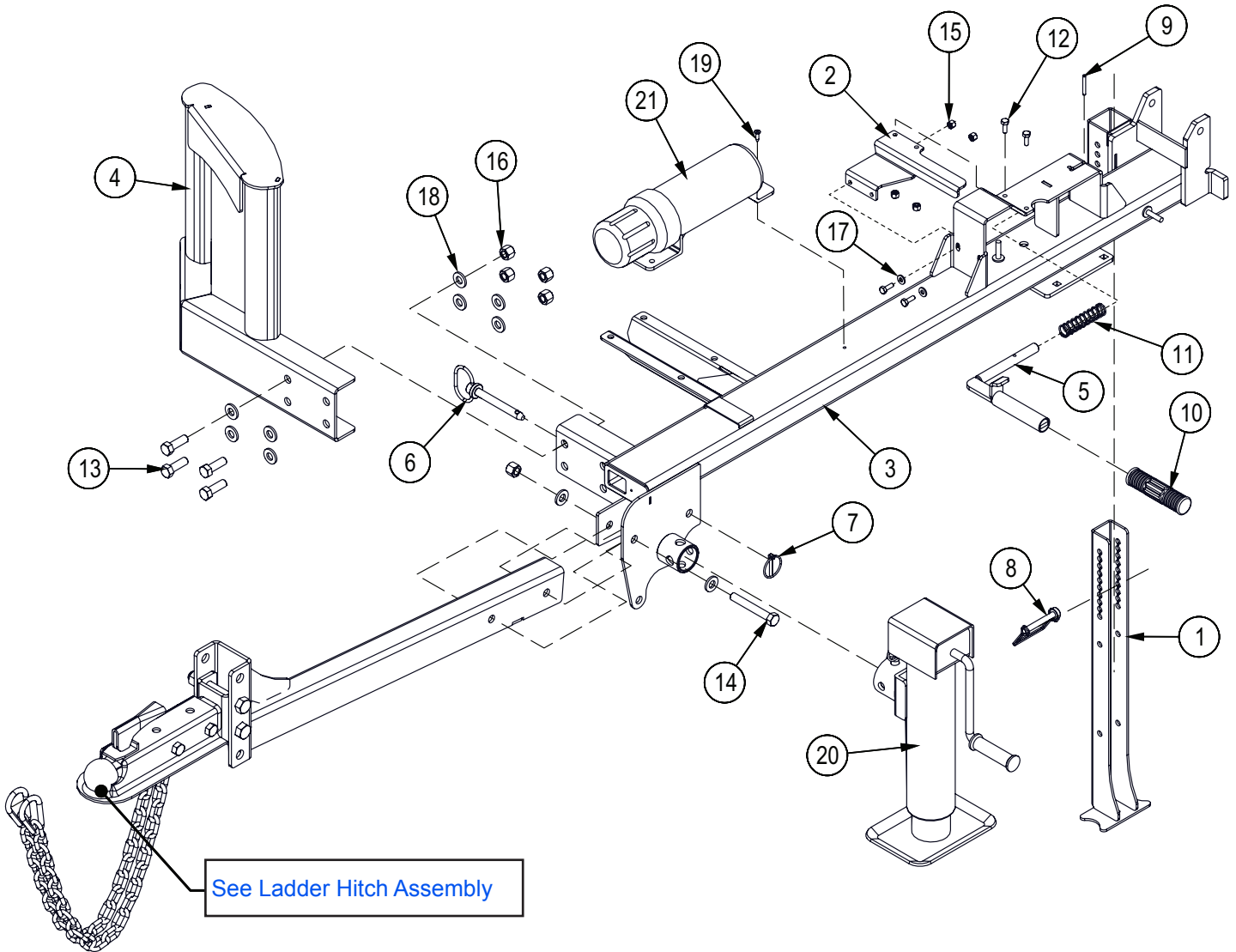

See Ladder Hitch Assembly

Item No.	Part No.	Description	Qty
1	2073L509	Channel, WXR Pro Rear Foot Stand	1
2	2073L535	Grip	1
3	2073W523	Tongue, WXR Pro	1
4	2073W526	Pro Engine Guard	1
5	2073W528	Pro Pivot Spring Handle	1
6	Z11222	Hitch Pin, 1/2" x 3-1/2"	1
7	Z12110	Lynch Pin, 3/16"	1
8	Z12432	Snap Lock Pin, 3/8" x 2-1/2"	1
9	Z14151	Roll Pin, 3/16" x 1-1/2"	1
10	Z19321	Handle Grip, 1"	1
11	Z32305	Comp Spring, 0.845" OD x 3-1/2" x 0.085"	1

Item No.	Part No.	Description	Qty
12	Z71107	Hex Bolt, 1/4NC x 3/4"	4
13	Z71515	Hex Bolt, 1/2NC x 1-1/2"	4
14	Z71535	Hex Bolt, 1/2NC x 3-1/2"	1
15	Z72211	Hex Lock Nut, 1/4NC	4
16	Z72251	Hex Lock Nut, 1/2NC	5
17	Z73111	SAE Washer, 1/4"	2
18	Z73151	SAE Washer, 1/2"	10
19	Z76721	Self-tapping Screw, 1/4" x 3/4"	1
20	Z91512	Trailer Jack, Side Wind x 2000lbs	1
21	Z96503	Manual Tube, 3-1/2" Short	1

Engine and Hydraulic Pump Detail

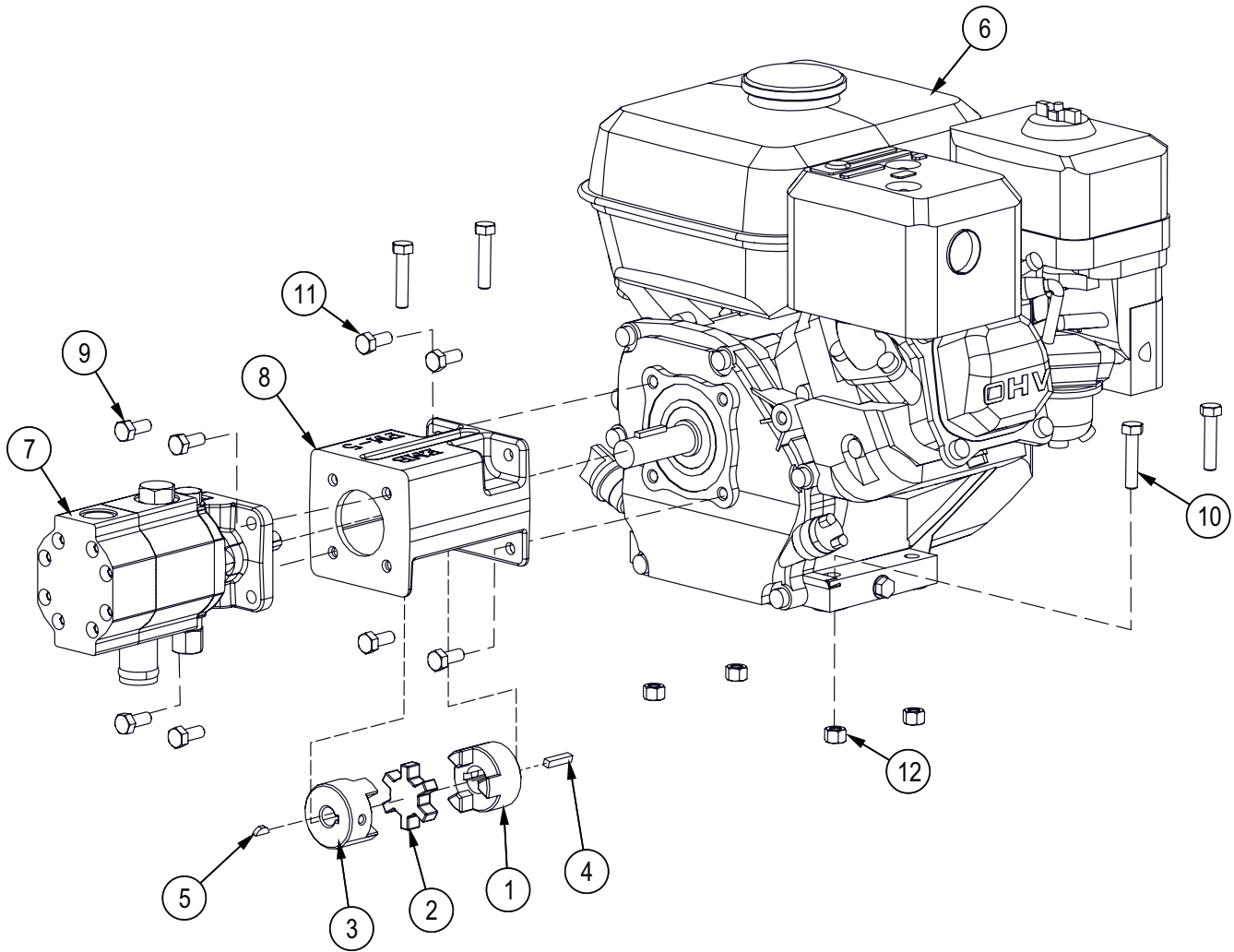

Item No.	Part No.	Description	Qty
1	Z46406	Shaft Coupler, L075 x 3/4"	1
2	Z46408	Spider, L075	1
3	Z46410	Shaft Coupling, L075 x 1/2"	1
4	Z46521	Key, 3/16" x 3/16" x 7/8"	1
5	Z46592	Woodruff Key, 1/8" x 1/2"	1
6	Z47131	Honda GX200UTQH6, Rope	1
7	Z53204	Two-Stage Pump, 11GPM	1
8	Z53801	Pump Mount, PM-5	1
9	Z71207	Hex Bolt, 5/16NC x 3/4"	4
10	Z71215	Hex Bolt, 5/16NC x 1-1/2"	4
11	Z71273	Hex Bolt, 5/16NF x 3/4"	4
12	Z72221	Hex Lock Nut, 5/16NC	4

Splitter Bed Assembly

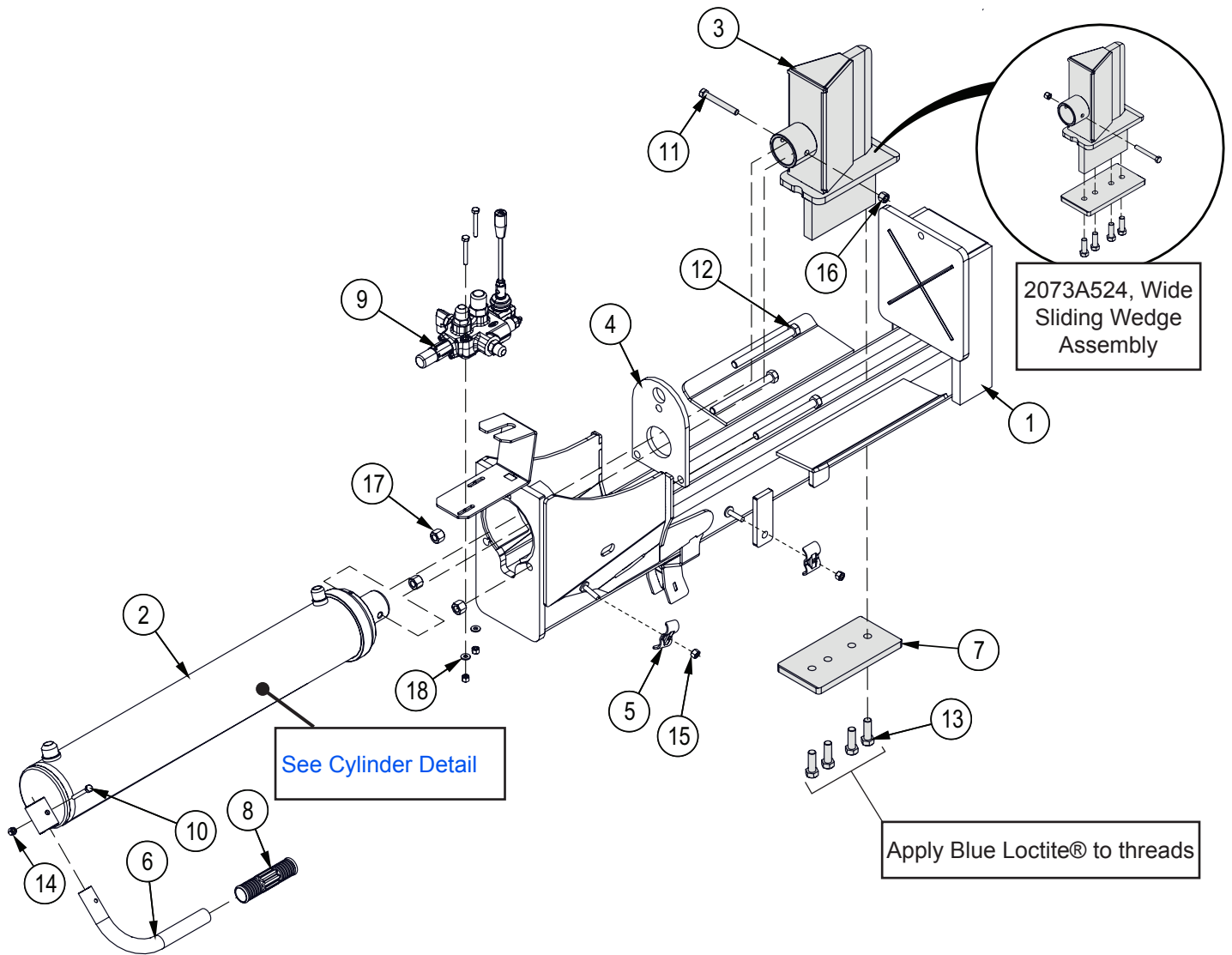

Item No.	Part No.	Description	Qty
1	2073W521	Splitter Bed, WXR545 Pro	1
2	2073C501	Cylinder, 4 x 24 x 2	1
3	2073W529	Sliding Wedge x 2" Rod	1
4	2014S421	Plate, Cylinder Retaining (Bolt)	1
5	2054L412	Clamp, Two Hose x 1/2"	2
6	2054S414	Handle, Lift	1
7	2014S414	Plate, Sliding Wedge Capture	1
8	Z19321	Handle Grip, 1"	1
9	Z56223	Single Spool Valve, OC Regen SCDK x 12GPM	1
10	Z71120	Hex Bolt, 1/4NC x 2"	3
11	Z71330	Hex Bolt, 3/8NC x 3"	1
12	Z71555	Hex Bolt, 1/2NC x 5-1/2"	3
13	Z71576G8	Hex Bolt, 1/2NF x 1-1/2" G8	4
14	Z72211	Hex Lock Nut, 1/4NC	3
15	Z72221	Hex Lock Nut, 5/16NC	2
16	Z72231	Hex Lock Nut, 3/8NC	1
17	Z72251	Hex Lock Nut, 1/2NC	3
18	Z73111	SAE Washer, 1/4"	2

Hitch Assembly

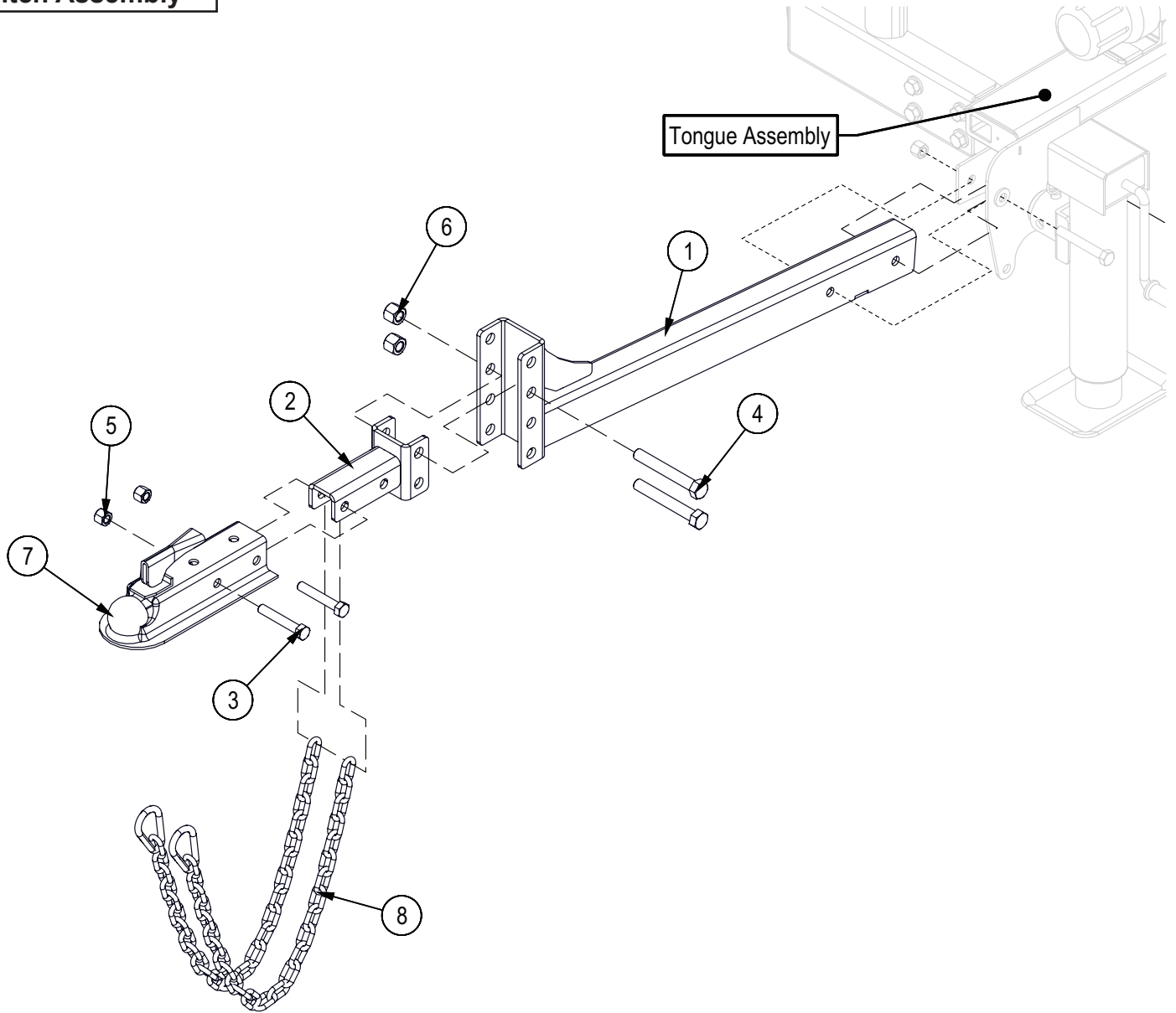

Item No.	Part No.	Description	Qty
1	2073W524	WXR545PL Ladder Hitch Tongue	1
2	2073W527	Ladder Hitch Adjuster	1
3	Z71530	Hex Bolt, 1/2NC x 3"	2
4	Z71645	Hex Bolt, 5/8NC x 4-1/2"	2
5	Z72251	Hex Lock Nut, 1/2NC	2
6	Z72261	Hex Lock Nut, 5/8NC	2
7	Z91614	Hitch Coupler, 2" Ball x 2" x 3500lbs	1
8	Z92307	Safety Chain, 1/4" x 3ft with Snap	2

Hub Detail

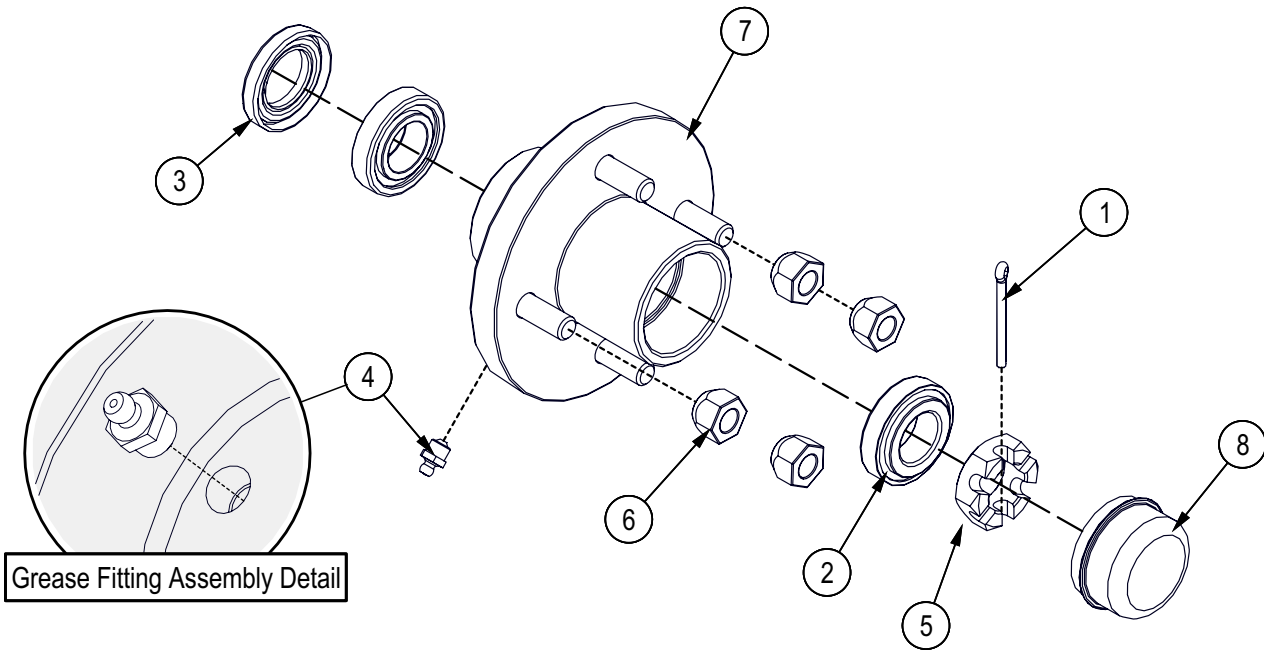

Item No.	Part No.	Description	Qty
1	Z12321	Cotter Pin, 3/16" x 1-3/4"	1
2	Z23201	Roller Bearing, L44643 L44610	2
3	Z28301	Double Lip Seal, 1-1/4"	1
4	Z29201	Grease Fitting, MP02	1
5	Z72691	Castle Nut, 1NF x 9/16" Thick	1
6	Z72931	Lug Nut, 1/2NF	4
7	Z91201	Hub, 1000lbs x 4on4	1
8	Z91801	Dust Cap, 1.98 Bore	1

Cylinder Detail

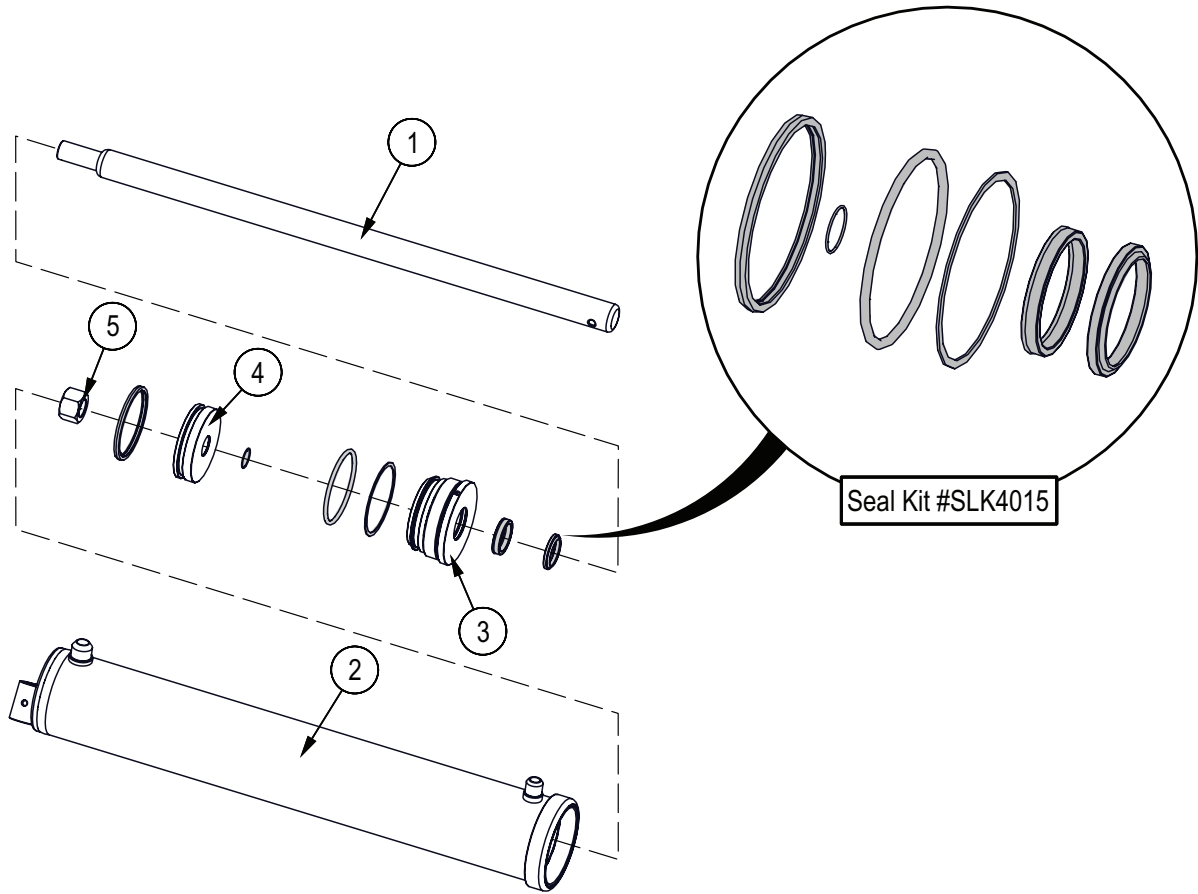

Item No.	Part No.	Description	Qty
1	2073C5012	Rod, 2 x 1	1
2	2073C5014	Barrel, 4"	1
3	G400-200S	Gland, 4" x 2"	1
4	P100-400SP	Piston, 4" Bore	1
5	Z722909G8	Hex Top-lock Nut 1-1/4NF G8	1

Hydraulic Plumbing Diagram

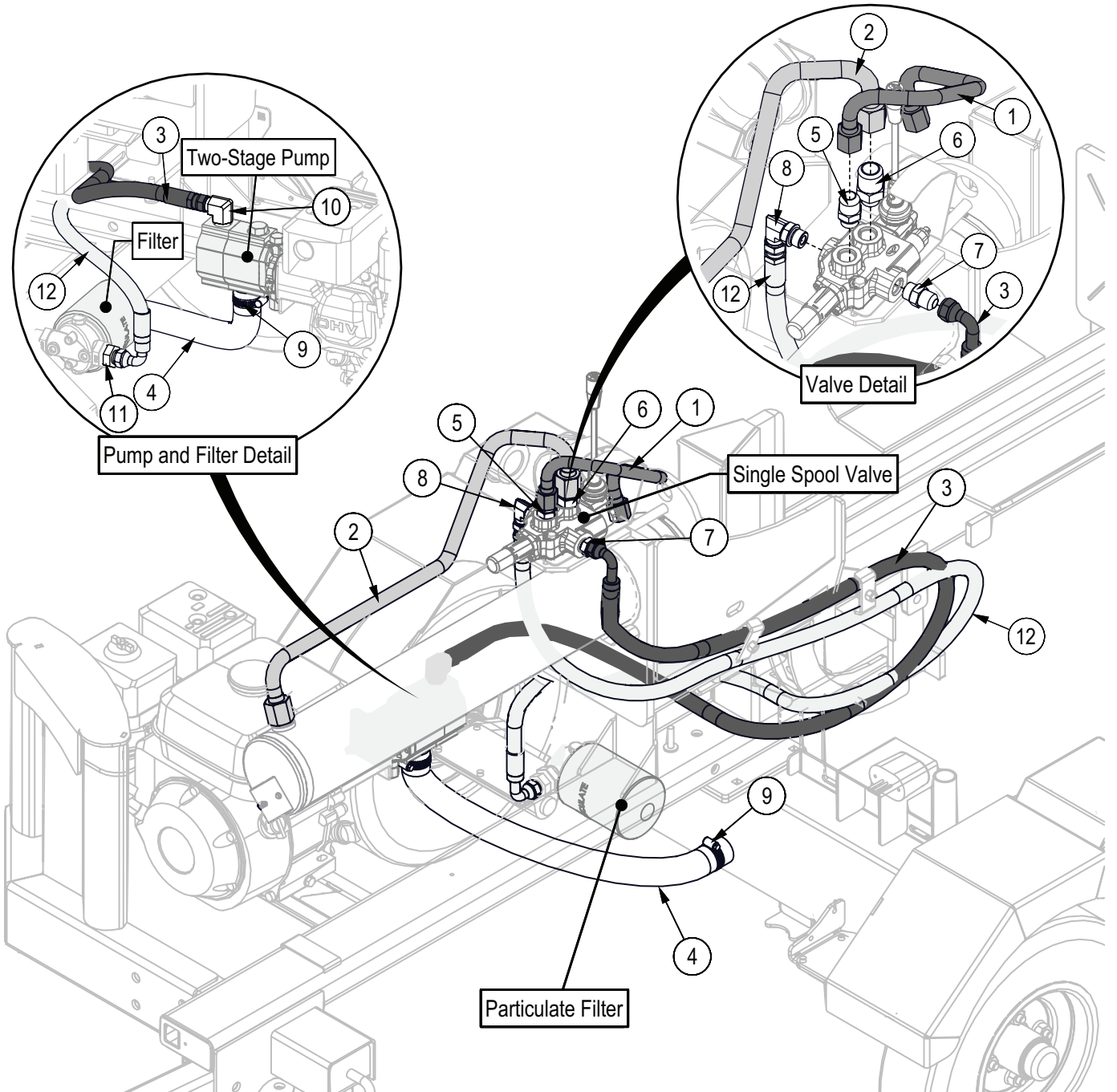

Item No.	Part No.	Description	Qty
1	2073F002	1/2" Tube, FJIC08 x FJIC08 x 16-7/8"	1
2	2073F004	3/4" Tube, FJICX10 x FJICX12 x 28-3/16"	1
3	2073F506	1/2" Hose, FJIC08 x 90FJIC08 x 68"	1
4	2073F001	Suction Hose, 1" x 24"	1
5	Z516410	Straight, MJIC x MORB 1008	1
6	Z516411	Straight, MJIC x MORB 1208	1
7	Z51643	Straight, MJIC x MORB 0808	1
8	Z51653	Elbow 90, MJIC x MORB 0808	1
9	Z79401	Hose Clamp, SAE #16 (1-1/2")	2
10	Z51451	Elbow 90, MJIC x MP 0808	1
11	Z51447	Straight, MJIC x MP 0812	1
12	2073F507	1/2" Hose, FJIC08 x 90FJIC08 x 68"	1

Wiring Harness and Lights

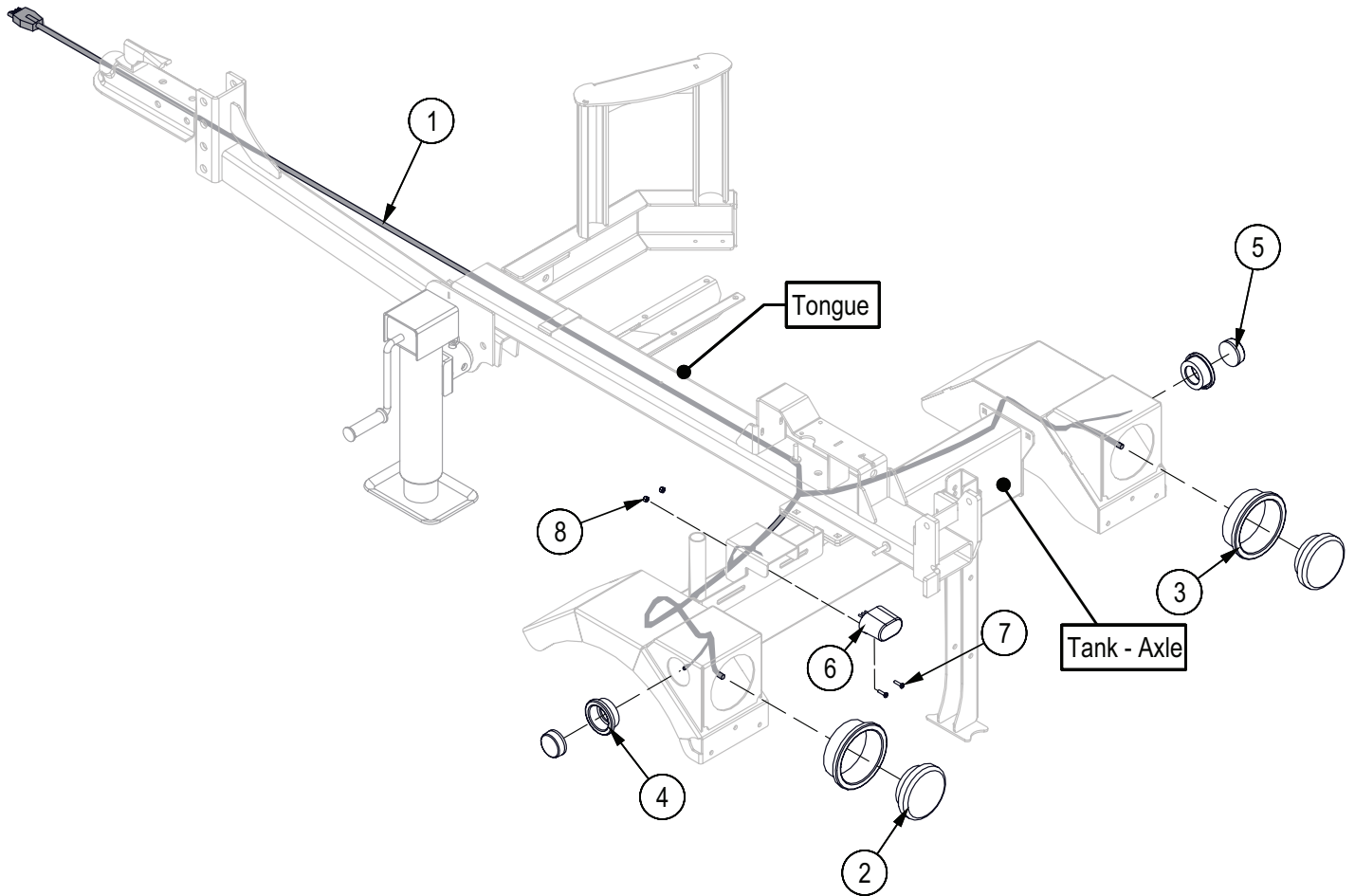

Item No.	Part No.	Description	Qty
1	2073F520	Harness, WXR Pro Lights	1
2	Z61115	STT LED, 4" Round	2
3	Z61116	Grommet, 4" Round x Open Back	2
4	Z61202	Grommet, Round x Open Back	2
5	Z61210	Marker LED, Round x Red	2
6	Z61301	License Lamp, White	1
7	Z78305	Machine Screw, #10 x 3/4"	2
6	Z61301	License Lamp, White	1
7	Z72203	Hex Lock Nut, #10NC	2

IMPORTANT! When assembling or replacing wire harnesses, apply a thin coating of silicone dielectric grease to the harness connectors.

Clean off any corrosion or loose particles, then apply a small amount to the surfaces of the connectors where they meet. The grease helps to stop any possibility of future corrosion.

Reassemble the connection. If grease squeezes out, wipe off with a rag or towel.

Accessories

Call your dealer for pricing and availability

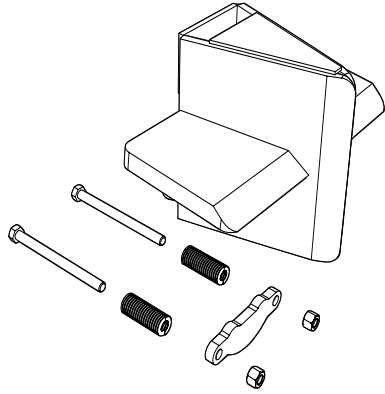
**W4130 – 4-way Wedge**

For WXR545 models. Bolts in place of existing wedge.

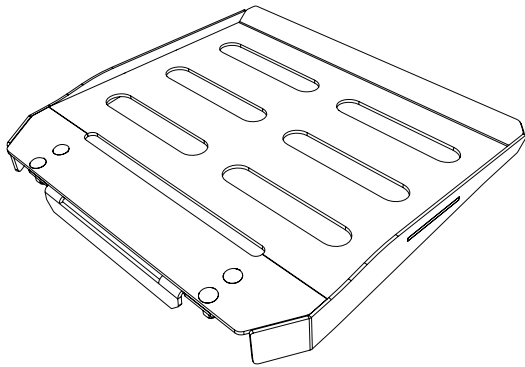
**W4211 – Clamp-on Shelf Extension**

Fits all WXR splitter models.

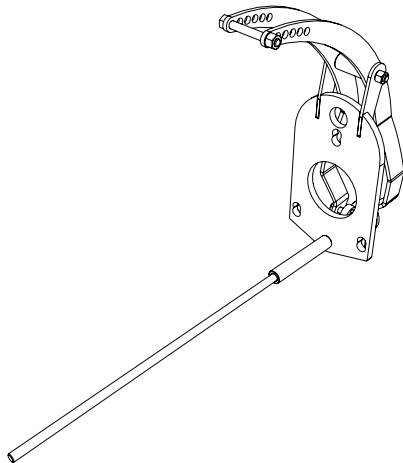
**W4213 – Stroke Limiter**

For WXR525 and WXR545 models. Manually set return stroke length.

Common Bolt Torque Values

Checking Bolt Torque

The tables shown give correct torque values for various bolts and capscrews. Tighten all bolts to the torque values specified in the table, unless indicated otherwise. Check tightness of bolts periodically.

IMPORTANT! If replacing hardware, use fasteners of the same grade.

IMPORTANT! Torque figures indicated in the table are for non-greased or non-oiled threads. Do not grease or oil threads unless indicated otherwise. When using a thread locker, increase torque values by 5%.

 **NOTE:** Bolt grades are identified by their head markings.

Imperial Bolt Torque Specifications

Bolt Diameter	Torque Value					
	SAE Gr. 2		SAE Gr. 5		SAE Gr. 8	
	lbf•ft	N•m	lbf•ft	N•m	lbf•ft	N•m
1/4"	6	8	9	12	12	17
5/16"	10	13	19	25	27	36
3/8"	20	27	33	45	45	63
7/16"	30	41	53	72	75	100
1/2"	45	61	80	110	115	155
9/16"	60	95	115	155	165	220
5/8"	95	128	160	215	220	305
3/4"	165	225	290	390	400	540
7/8"	170	230	420	570	650	880
1"	225	345	630	850	970	1320



SAE Gr. 2



SAE Gr. 5



SAE Gr. 8

Metric Bolt Torque Specifications

Bolt Diameter	Torque Value			
	Gr. 8.8		Gr. 10.9	
	lbf•ft	N•m	lbf•ft	N•m
M3	0.4	0.5	1.3	1.8
M4	2.2	3	3.3	4.5
M6	7	10	11	15
M8	18	25	26	35
M10	37	50	52	70
M12	66	90	92	125
M16	166	225	229	310
M20	321	435	450	610
M30	1,103	1 495	1,550	2 100
M36	1,917	2 600	2,700	3 675



8.8



10.9

Hydraulic Fitting Torque

Tightening Flare Type Tube Fittings

1. Check flare and flare seat for defects that might cause leakage.
2. Align tube with fitting before tightening.
3. Hand-tighten swivel nut until snug.
4. To prevent twisting the tube, use two wrenches. Place one wrench on the connector body and tighten the swivel nut with the second. Torque to values shown.

If a torque wrench is not available, use the FFFT (Flats From Finger Tight) method.

Hydraulic Fitting Torque					
Tube Size OD	Hex Size Across Flats	Torque value		Flats From Finger Tight	
		lbf•ft	N•m	Flats	Turns
3/16	7/16	6	8	2	1/6
1/4	9/16	11–12	15–17	2	1/6
5/16	5/8	14–16	19–22	2	1/6
3/8	11/16	20–22	27–30	1-1/4	1/6
1/2	7/8	44–48	59–65	1	1/6
5/8	1	50–58	68–79	1	1/6
3/4	1-1/4	79–88	107–119	1	1/8
1	1-5/8	117–125	158–170	1	1/8

Values shown are for non-lubricated connections.

Wheel Lug Torque

It is extremely important safety procedure to apply and maintain proper wheel mounting torque on your trailer axle. Torque wrenches are the best method to assure the proper amount of torque is being applied to a fastener.

Wheel lugs should be torqued before first road use and after each wheel removal. Check and re torque after the first 10 miles (16 km), 25 miles (40 km), and again at 50 miles (80 km). Check periodically thereafter.

NOTE: *Wheel lugs must be applied and maintained at the proper torque levels to prevent loose wheels, broken studs, and possible dangerous separation of wheels from your axle.*

- Start all lugs by hand to prevent cross threading.
- Tighten lugs in sequence, per wheel lug torque sequence chart.
- The tightening of the fasteners should be done in stages. Following the recommended sequence, tighten fasteners per wheel torque requirements chart.

Wheel Lug Nut Torque				
Wheel Size	Units	1st Stage	2nd Stage	3rd Stage
8"	lbf•ft N•m	12–20 16–26	30–35 39–45.5	45–55 58.5–71.5
12"	lbf•ft N•m	20–25 26–32.5	35–40 45.5–52	50–60 65–78
13"	lbf•ft N•m	20–25 26–32.5	35–40 45.5–52	50–60 65–78
14"	lbf•ft N•m	20–25 26–32.5	50–60 65–78	90–120 117–156
15"	lbf•ft N•m	20–25 26–32.5	50–60 65–78	90–120 117–156
16"	lbf•ft N•m	20–25 26–32.5	50–60 65–78	90–120 117–156

Wheel Lug Torque Pattern

