

PARTS MANUAL

Serial number 1101273 and up

WP245 Firewood Processor

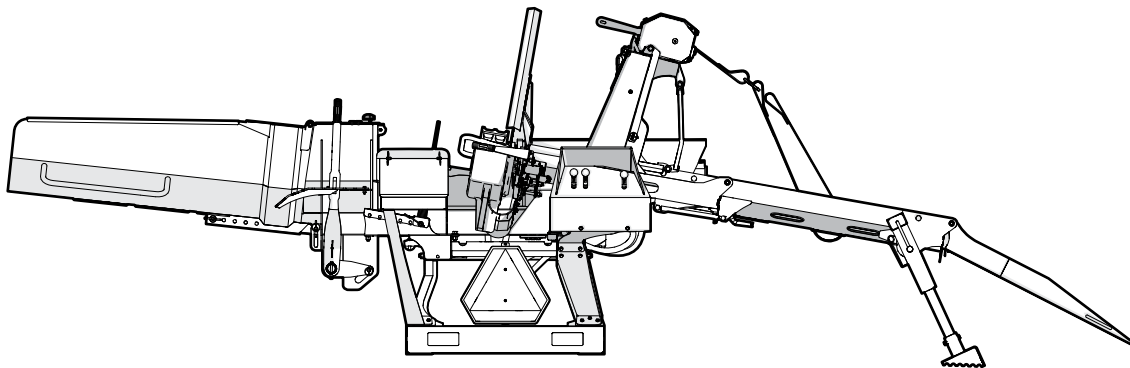

Revision C Apr-2024

Part Number: 2210T005

WALLENSTEIN

Table of Contents

Introduction3

Model and Serial Number Location.....3

Splitter Chute Assembly4

Lead In Chute Assembly.....5

Log Hold Down Assembly6

Splitter Assembly7

Log Chute Assembly8

Chain Saw Adapter.....9

Three-Point Hitch Frame Assembly.....10

Hydraulic Splitter Assembly11

Hydraulic Winch12

Hydraulic Winch Drum13

Valve Assembly14

Closed Center Plug15

Hydraulic Circuit.....16

Label Locations17

Label Locations18

Label Locations19

Accessories20

Accessories21

Bolt Torque22

Hydraulic Fitting Torque.....23

Introduction

! WARNING!

For safety, operation, and maintenance information, see the Operator’s Manual for your product.

Only qualified people are approved to maintain the machine.

! WARNING!

Replace all safety labels that are missing, damaged, or illegible. If a component is replaced and it has a safety label on it, apply a safety label to the new component. Operating the machine with missing, damaged, or illegible safety labels puts the operator at risk of serious injury or death.

W100

This document provides information about the original equipment manufacturer (OEM) components (parts). Always replace a part with the correct OEM part. For service, support, or to order parts, contact your local Wallenstein Equipment dealer or distributor.

Always provide the model and serial number of your Wallenstein product when you order parts, or request service or other information. The model and serial number location is shown in the following illustration.

Record the model and serial number of your product here:

Model	
Serial Number	

The information contained in this document was current at the revision date noted on the bottom of each page. Wallenstein Equipment reserves the right to change product specifications at any time without notice. If your product specifications are different from the information in this document, contact your local dealer or distributor. To find a local dealer or distributor, go to WallensteinEquipment.com and select **Dealer Locator** at the bottom of the page.

Wallenstein Equipment Inc. • © 2023. All rights reserved.

No part of this work may be copied, reproduced, replaced, distributed, published, displayed, modified, or transferred in any form or by any means except with the prior permission of Wallenstein Equipment Inc.

Model and Serial Number Location

Model Configuration

WP245

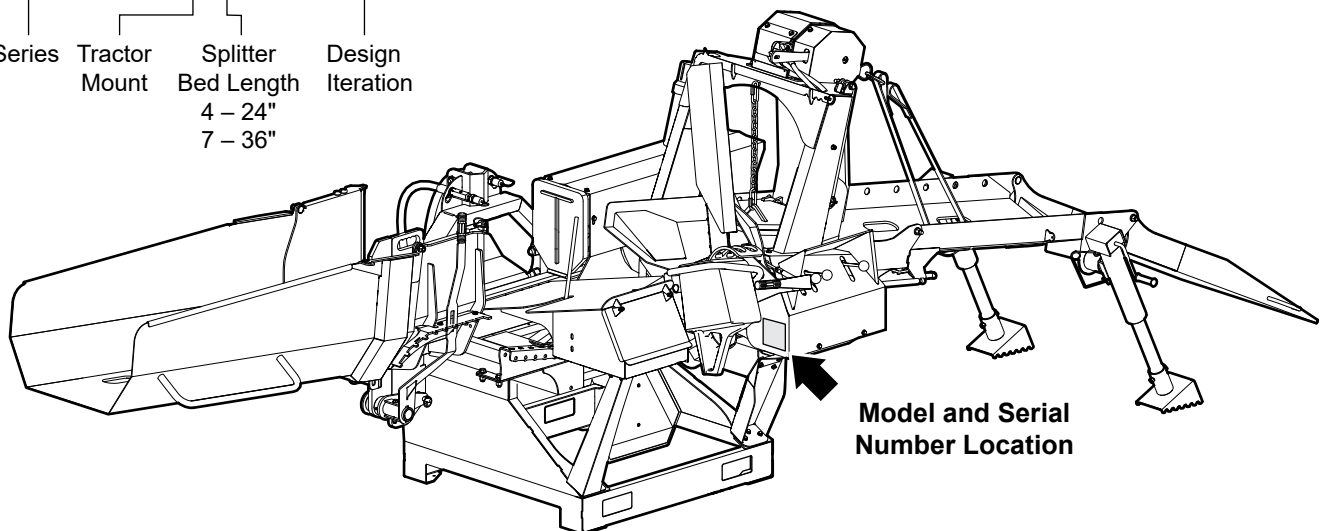
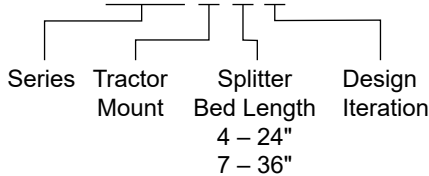

Model and Serial Number Location

Splitter Chute Assembly

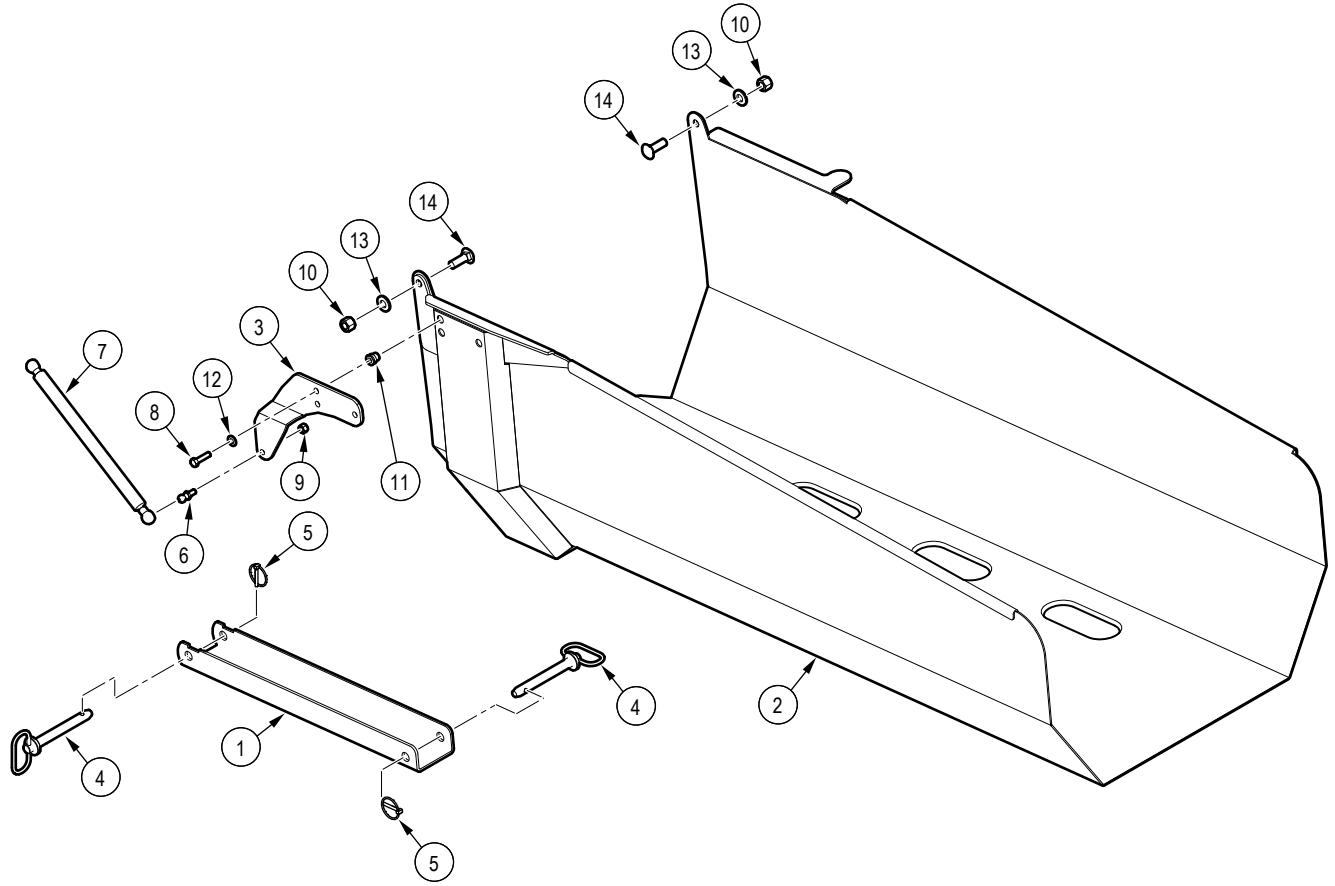

Item	Part number	Description	Quantity
1	2071L164	Channel, Chute Adjust	1
2	2071S209	Handle,Chute Lift	1
3	2261W065	Splitter Chute	1
4	Z11232	Hitch Pin, 5/8" x 4-1/4"	2
5	Z12110	Lynch Pin, 3/16"	2
6	Z34204	Ball Stud, 13mm x 5/16NC	2
7	Z34216	Gas Spring, 10mm OD x 540mm x 215mm x 250 lbs	1

Item	Part number	Description	Quantity
8	Z71212	Hex Bolt, 5/16NC x 1-1/4"	3
9	Z72221	Hex Lock Nut 5/16NC	2
10	Z72251	Hex Lock Nut 1/2NC	1
11	Z72956	Rivet Nut, 5/16NC x 150	3
12	Z73122G8	SAE Washer, 5/16" Grade 8	3
13	Z73151G8	SAE Washer, 1/2" Grade 8	2
14	Z76251	Carriage Bolt 1/2NC x 1-1/2	2

Lead In Chute Assembly

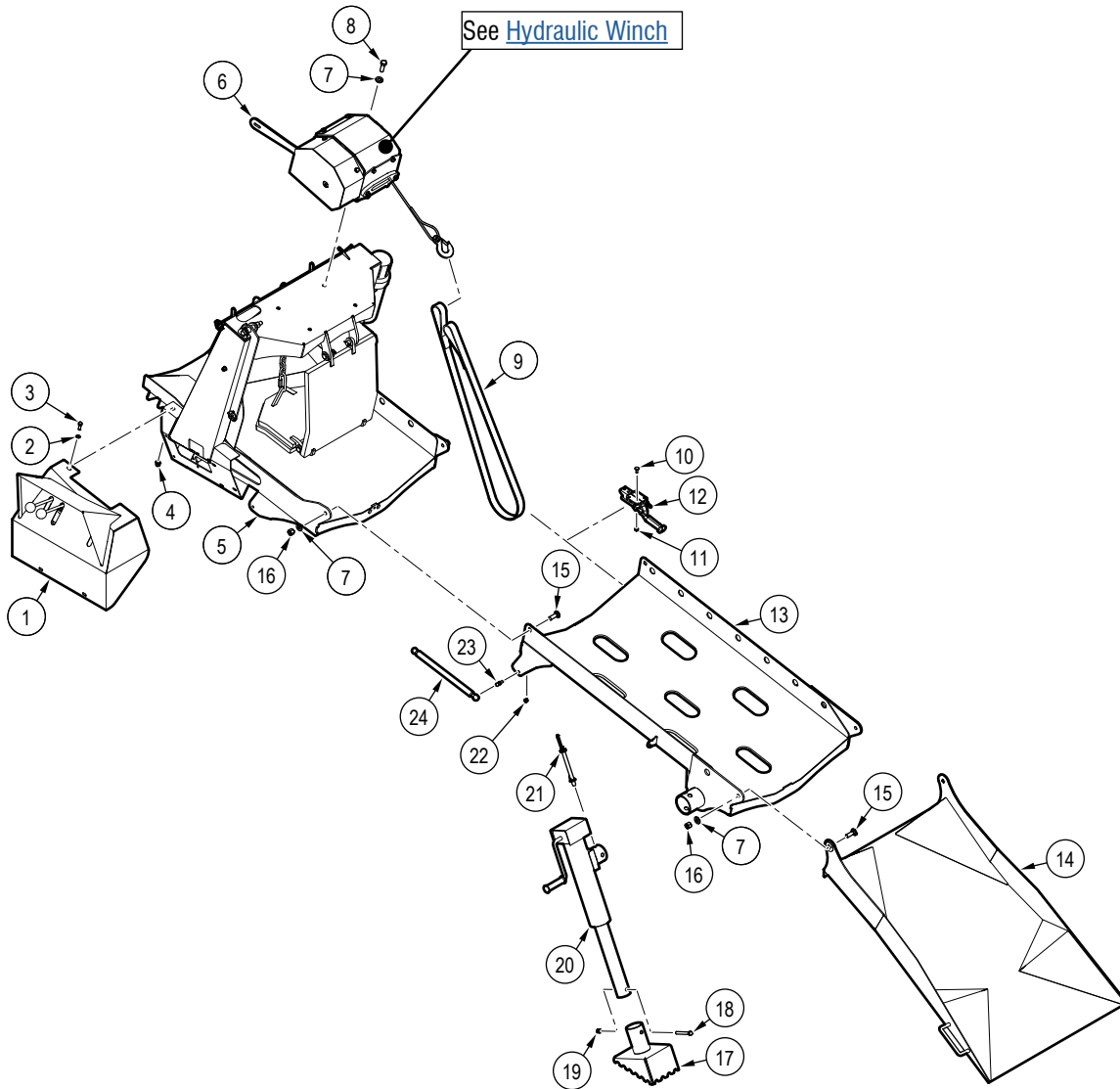

Item	Part number	Description	Quantity
1	2210W062	Valve Cover	1
2	Z73122G8	SAE Washer, 5/16" Grade 8	3
3	Z71210	Hex Bolt, 5/16NC x 1"	3
4	Z72956	Rivet Nut, 5/16NC x 150	3
5	2251W063	Chute, Log WP200	1
6	2251A055	Hydraulic Winch Assembly	1
7	Z73151G8	SAE Washer, 1/2" Grade 8	8
8	Z71515	Hex Bolt, 1/2NC x 1-1/2"	4
9	Z92405	Winching Strap, 1" x 5ft	1
10	Z76211	Carriage Bolt, 1/4NC x 3/4"	8
11	Z72511	Serrated Flange Locknut, 1/4NC	8
12	Z19511	Handle Clamp, Latch Type x 2-Piece	2

Item	Part number	Description	Quantity
13	2251W070	Chute, Bottom	1
14	2251W055	Chute, Lead In	1
15	Z76251	Carriage Bolt, 1/2NC x 1-1/2"	4
16	Z72251	Hex Lock Nut, 1/2NC	4
17	2251W066	Foot, Jack	2
18	Z71330	Hex Bolt, 3/8NC x 3"	2
19	Z72231	Hex Lock Nut, 3/8NC	2
20	Z91515	Trailer Jack, Side Wind x 2000lbs No Foot	2
21	Z12441	Snap Lock Pin, 1/2" x 4-1/2"	2
22	Z72221	Hex Lock Nut, 5/16NC	2
23	Z34204	Ball Stud, 13mm x 5/16NC	4
24	Z34216	Gas Spring, 10mm OD x 540mm x 215mm x 250 lbs	2

Log Hold Down Assembly

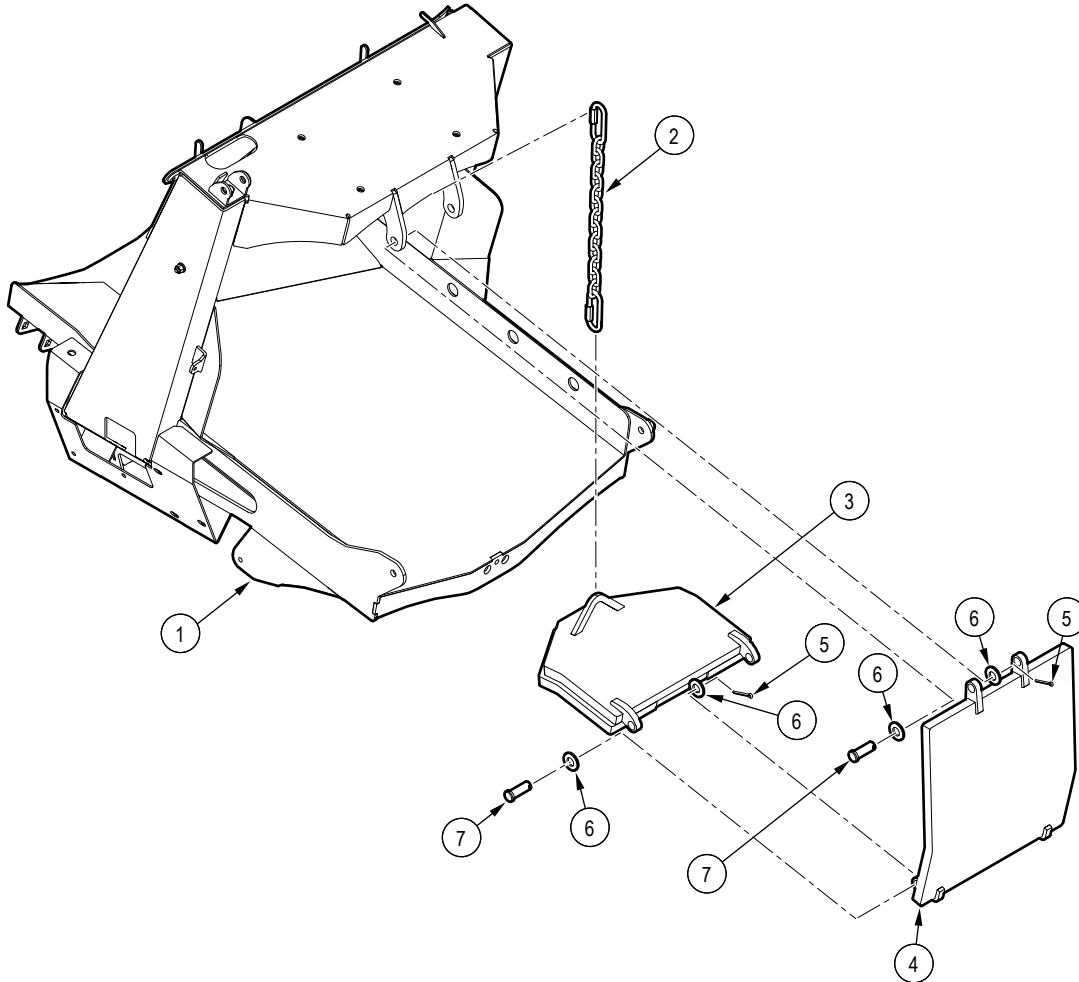

Item	Part number	Description	Quantity
1	2251W063	Chute, Log WP200	1
2	Z92311	Chain, 1/4" x 21" with Two Quicklinks	1
3	2251W074	Weldment, Lower Log Hold Down	1
4	2251W073	Weldment, Upper Log Hold Down	1

Item	Part number	Description	Quantity
5	Z12311	Cotter Pin, 1/8" x 1"	4
6	Z73161G8	SAE Washer, 5/8" Grade 8	8
7	Z11361	Clevis Pin, 5/8" x 1-1/2"	4

Splitter Assembly

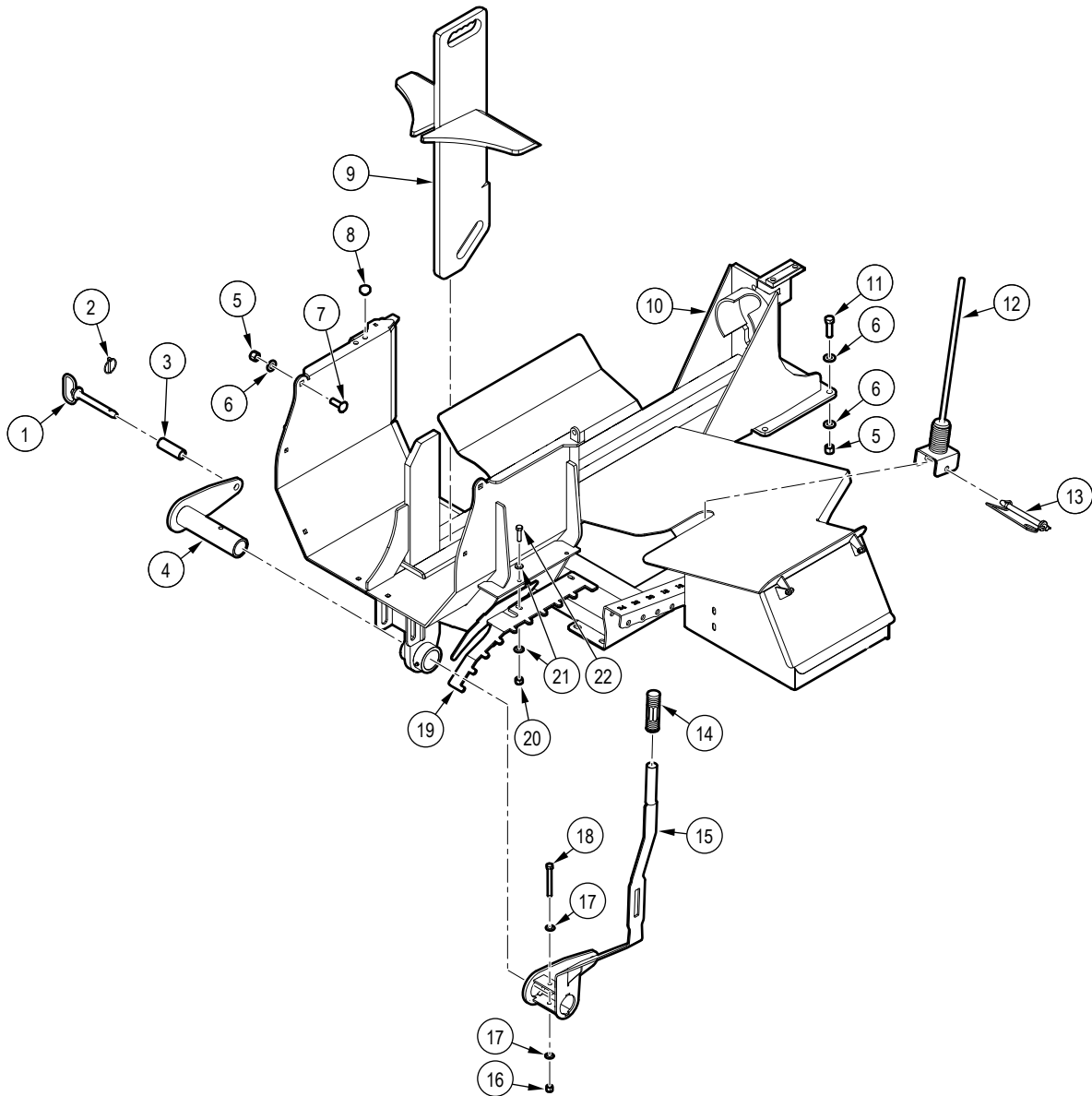

Item	Part number	Description	Quantity
1	Z11232	Hitch Pin, 5/8" x 4-1/4"	1
2	Z12110	Lynch Pin, 3/16"	1
3	2071M123	Roller Wedge Lift	1
4	2251W072	Arm Wedge Liftavr	1
5	Z72251	Hex Lock Nut, 1/2NC	6
6	Z73151G8	SAE Washer, 1/2" Grade 8	12
7	Z76251	Carriage Bolt, 1/2NC x 1-1/2"	2
8	Z19909	Rubber Bumper, 7/16" x 1"	4
9	2071L540	Spine, Wedge	1
10	2251W067	Weldment, Main Frame	1
11	Z71517	Hex Bolt, 1/2NC x 1-3/4"	4

Item	Part number	Description	Quantity
12	2071W190	Log Stop Whip	1
13	Z12441	Snap Lock Pin, 1/2" x 4-1/2"	1
14	Z19321	Handle Grip, 1"	1
15	2251W071	Wedge Position Handle	1
16	Z72231	Hex Lock Nut, 3/8NC	1
17	Z73131G8	SAE Washer, 3/8" Grade 8	2
18	Z71332	Hex Bolt, 3/8NC x 3-1/4"	1
19	2251W058	Rack, Wedge Lever	1
20	Z72221	Hex Lock Nut, 5/16NC	2
21	Z73122G8	SAE Washer, 5/16" Grade 8	4
22	Z71212	Hex Bolt, 5/16NC x 1-1/4"	2

Log Chute Assembly

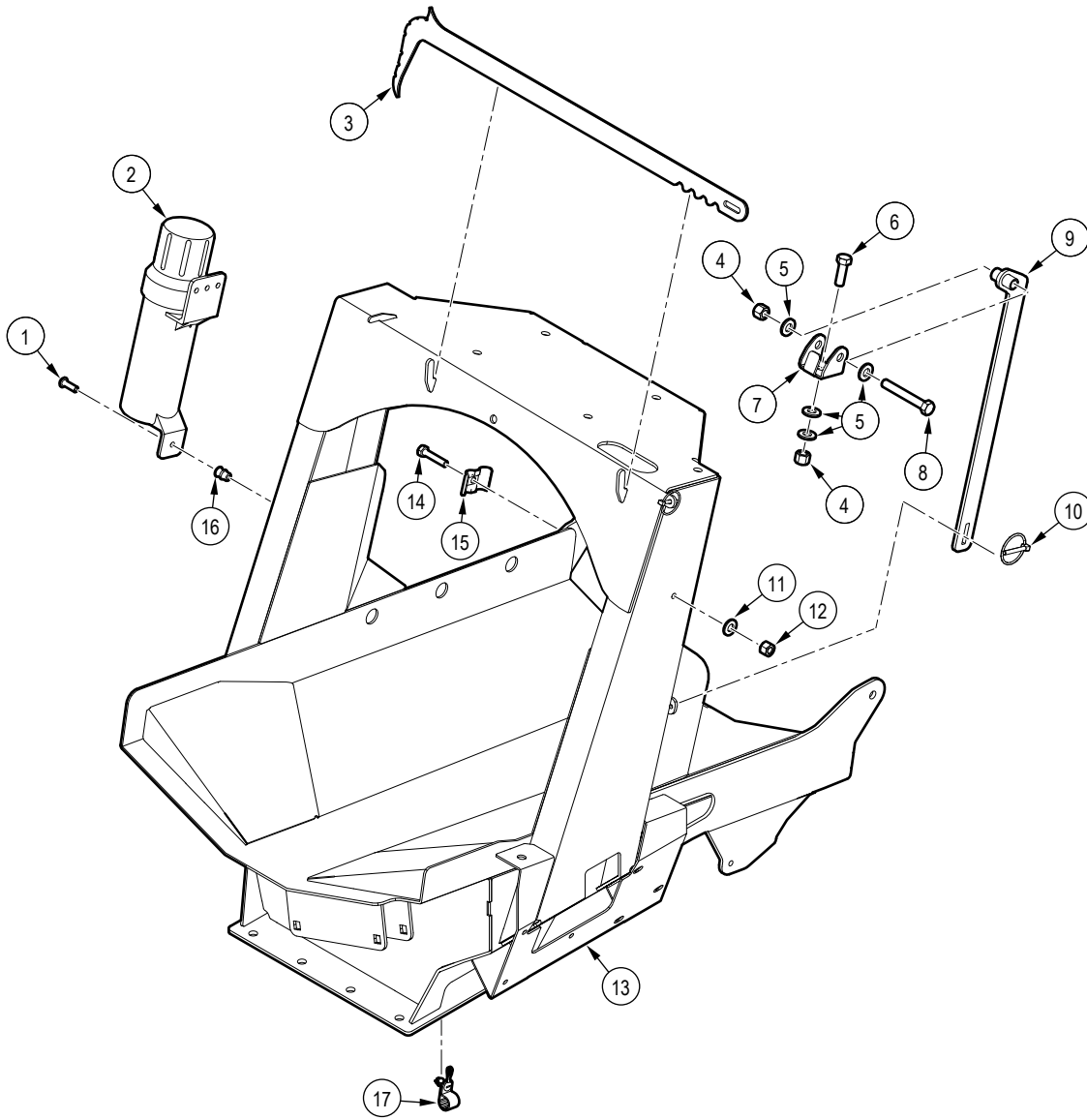

Item	Part number	Description	Quantity
1	Z78301	BHCS, 1/4NC x 3/4", Hex Drive	4
2	Z96503	Manual Tube, 3-1/2" Short	1
3	2250L223	Hookaroon, 30"	1
4	Z72251	Hex Lock Nut, 1/2NC	2
5	Z73151G8	SAE Washer, 1/2" Grade 8	4
6	Z71515	Hex Bolt, 1/2NC x 1-1/2"	1
7	2071L123	Clevis, Latch Mount	1
8	Z71535	Hex Bolt, 1/2NC x 3-1/2"	1

Item	Part number	Description	Quantity
9	2071W121	Arm, Log Chute Lock	1
10	Z12110	Lynch Pin, 3/16"	1
11	Z73122G8	SAE Washer, 5/16" Grade 8	1
12	Z72221	Hex Lock Nut, 5/16NC	1
13	2251W063	Chute, Log WP200	1
14	2250L286	Hose Clamp, 2 x 3/8"	1
15	Z71215	Hex Bolt, 5/16NC x 1-1/2"	1
16	Z72962	Rivet Nut, 1/4NC x 260	4

Chain Saw Adapter

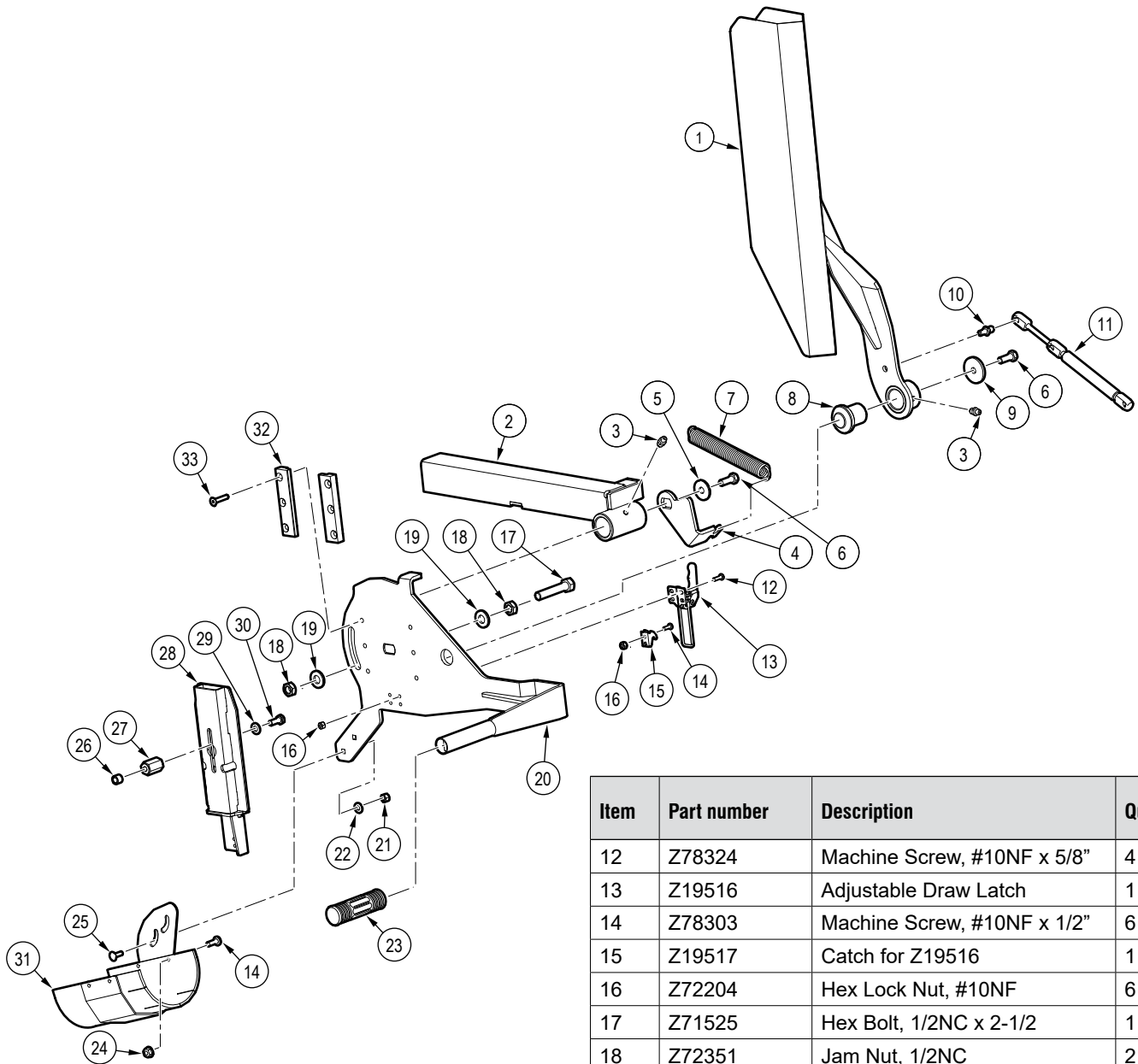

Item	Part number	Description	Quantity
1	2089L5505	Chainsaw Guard, Nonadjustable	1
2	2089W586	Pivot Base	1
3	Z29202	Grease Fitting, 1/4NF	2
4	2089L5507	Pivot Stop Washer	1
5	2089L5501	Washer	1
6	Z71310	Hex Bolt, 3/8NC x 1"	2
7	Z31404	Ext Spring, 25mm OD x 178mm x 0.135	1
8	2089M563	Chainsaw Guard Pivot Pin	1
9	2089L555	Washer	1
10	Z34208	Ball Stud, 10mm x 5/16NC	2
11	Z34209	Gas Spring, 8mm x 9.65" x 3.15" x 56 lbs	1

Item	Part number	Description	Quantity
12	Z78324	Machine Screw, #10NF x 5/8"	4
13	Z19516	Adjustable Draw Latch	1
14	Z78303	Machine Screw, #10NF x 1/2"	6
15	Z19517	Catch for Z19516	1
16	Z72204	Hex Lock Nut, #10NF	6
17	Z71525	Hex Bolt, 1/2NC x 2-1/2	1
18	Z72351	Jam Nut, 1/2NC	2
19	Z73151G8	SAE Washer, 1/2" Grade 8	2
20	2251L115	Chainsaw Pivot Base	1
21	Z72211	Hex Lock Nut, 1/4NC	2
22	Z73111G8	SAE Washer, 1/4" Grade 8	2
23	Z19321	Handle Grip, 1"	1
24	Z72503	Serrated Flange Locknut, #10NF	4
25	Z76211	Carriage Bolt, 1/4NC x 3/4"	2
26	2089M571	Carriage Bolt, 1/4NC x 3/4"	2
27	2089M570	Bar Mounting Stud	2
28	2251W045	Universal Chainsaw Adapter	1
29	Z73122	SAE Washer, 5/16"	2
30	Z77150	Hex Bolt, M8x1.25 x 20mm	2
31	2089S592	Debris Chute	1
32	2251M009	Guide Gusset Block	2
33	Z75214	FHCS, 1/4NC x 1-1/4"	2

Three-Point Hitch Frame Assembly

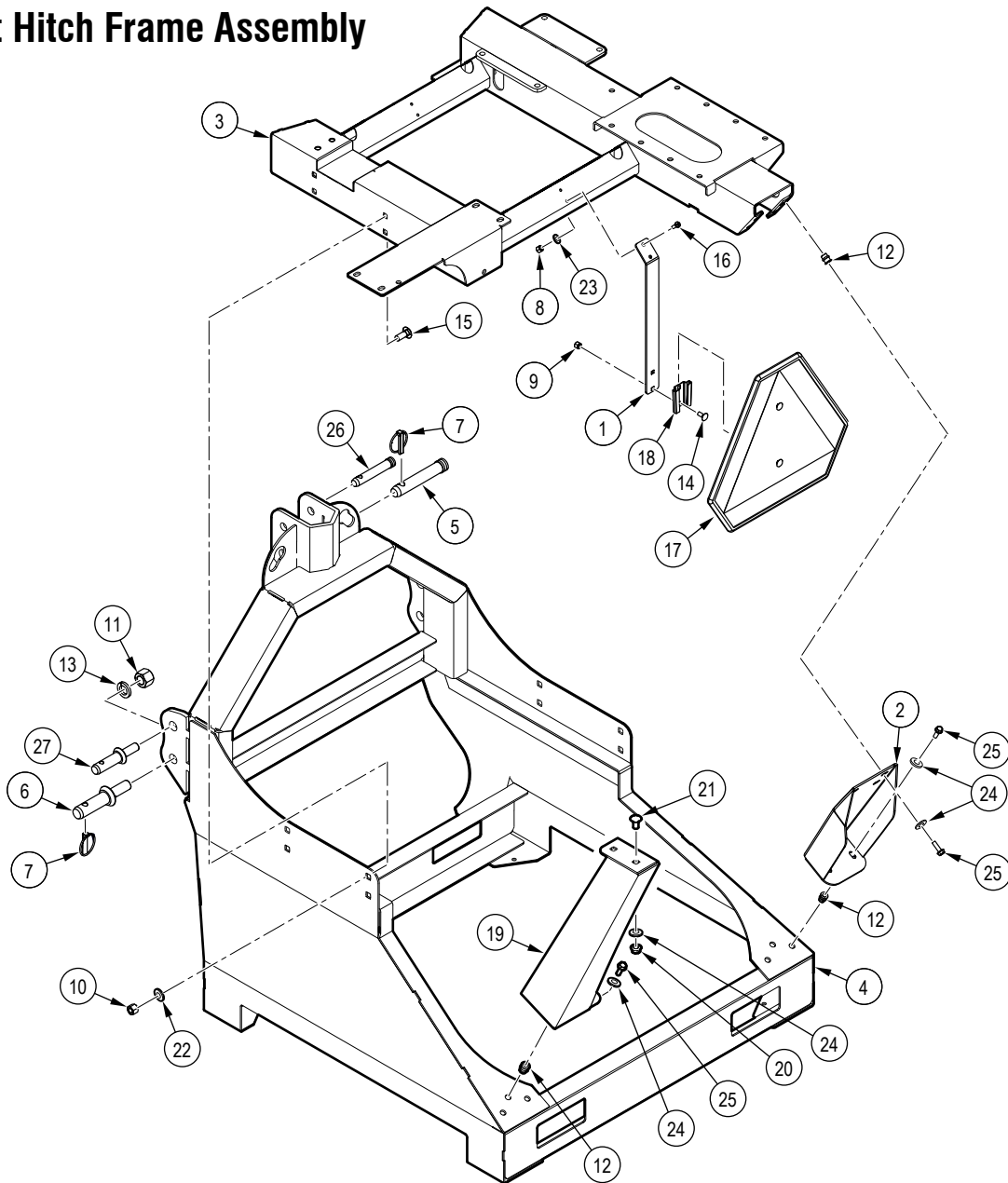

Item	Part number	Description	Quantity
1	2019L922	SMV Post	1
2	2210L015	Brace, 3PH	1
3	2210W058	WP3PH Frame Adapter	1
4	2210W046	WP 3PH Base	1
5	Z11142	Toplink Pin, 1" x 4-5/16"	1
6	Z11442v	Implement Pin, 1-1/8" x 2-1/4" x 7/8NF	2
7	Z12140	Lynch Pin 7/16"	6
8	Z72211	Hex Lock Nut, 1/4NC	2
9	Z72221	Hex Lock Nut, 5/16NC	2
10	Z72251	Hex Lock Nut, 1/2NC	8
11	Z72282	Hex Lock Nut, 7/8 NF	4
12	Z72957	River Nut, 5/16 NC x 312	10
13	Z73381	Split Lock Washer, 7/8"	4
14	Z76221	Carriage Bolt, 5/16 NC x 3/4"	2

Item	Part number	Description	Quantity
15	Z76251	Carriage Bolt, 1/2NC x 1-1/2"	8
16	Z78301	BHCS, 1/4NC x 3/4", Hex Drive	2
17	Z96605	SMV Sing With Spade, Assembled	1
18	Z96603	SMV Socket	1
19	2210W047	Brace, Toolbox	1
20	Z72231	Hex Lock Nut, 3/8NC	2
21	Z76231	Carriage Bolt, 3/8NC x 1"	2
22	Z73151G8	SAE Washer, 1/2" Grade 8	8
23	Z73111G8	SAE Washer, 1/4" Grade 8	2
24	Z73131G8	SAE Washer 3/8" Grade *	2
25	Z71212	Hex Bolt, 5/16NC x 1-1/4"	7
26	Z11122	Toplink Pin, 3/4" x 3-7/8"	1
27	Z11431	Implement Pin, 7/8" x 1-3/4" x 7/8NF	2

Hydraulic Splitter Assembly

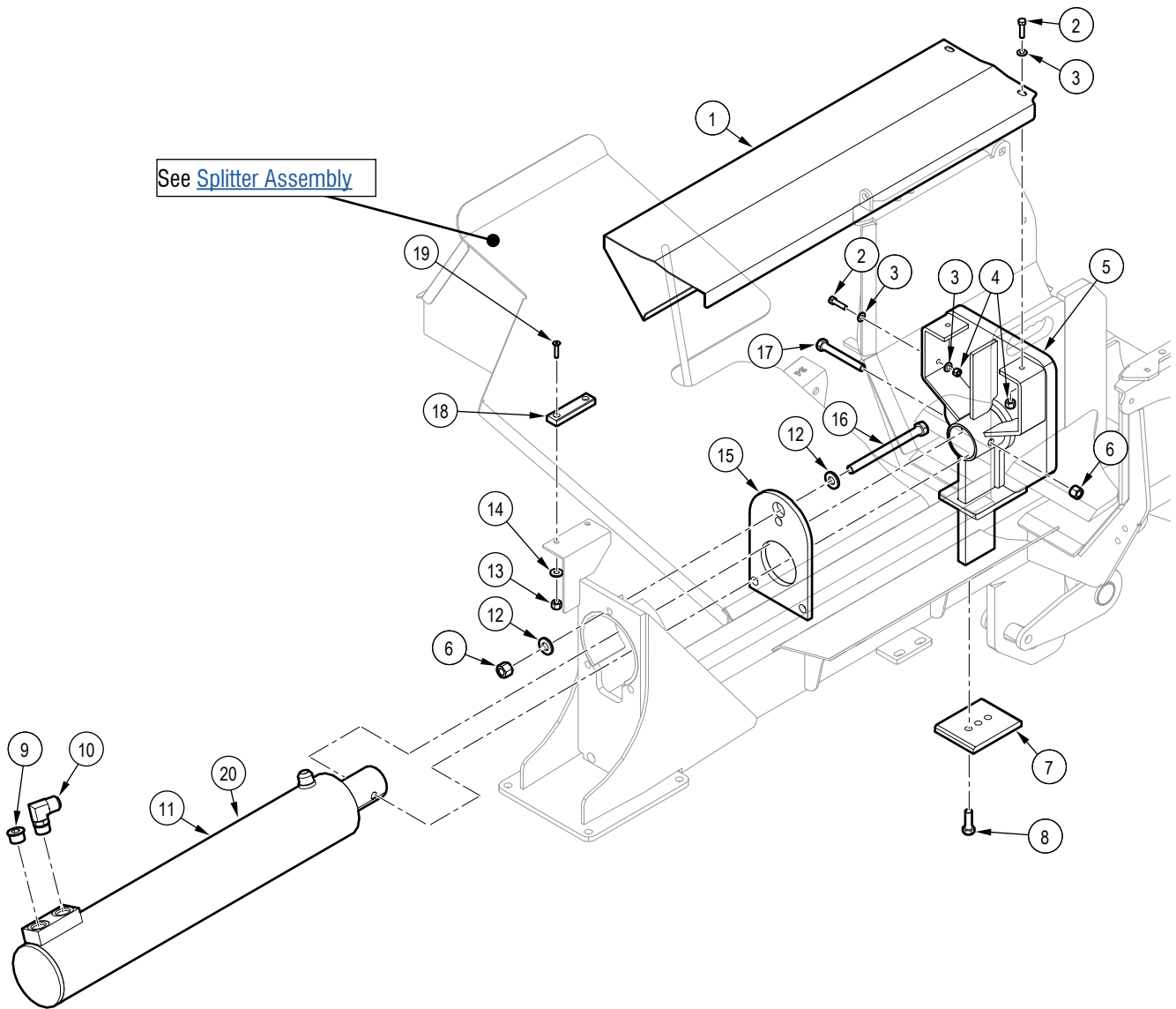

Item	Part number	Description	Quantity
1	2251L009	Cover, Sliding	1
2	Z71212	Hex Bolt, 5/16NC x 1-1/4"	3
3	Z73122G8	SAE Washer, 5/16" Grade 8	4
4	Z72221	Hex Lock Nut, 5/16NC	1
5	2251W053	Hvy Push Block	1
6	Z72251	Hex Lock Nut, 1/2NC	4
7	2055S517	Cap, Push Block	1
8	Z71576G8	Hex Bolt, 1/2NF x 1-1/2" G8	3
9	Z51695	Socket Plug, MORB 12	1
10	Z516501	Elbow 90, MJIC x MORB 1212	1

Item	Part number	Description	Quantity
11	2251C001	Cylinder, 4-1/2 x 24 x 2-1/2	1
12	Z73151G8	SAE Washer, 1/2" Grade 8	6
13	Z72211	Hex Lock Nut, 1/4NC	2
14	Z73111G8	SAE Washer, 1/4" Grade 8	2
15	2071L215	Plate, Cylinder Retaining	1
16	Z71560	Hex Bolt, 1/2NC x 6"	3
17	Z71540	Hex Bolt, 1/2NC x 4"	1
18	1022S208	Rotor Hood Slide	1
19	Z75214	FHCS, 1/4NC x 1-1/4"	2
20	SLK-4525	Seal Kit (not shown)	1

Hydraulic Winch

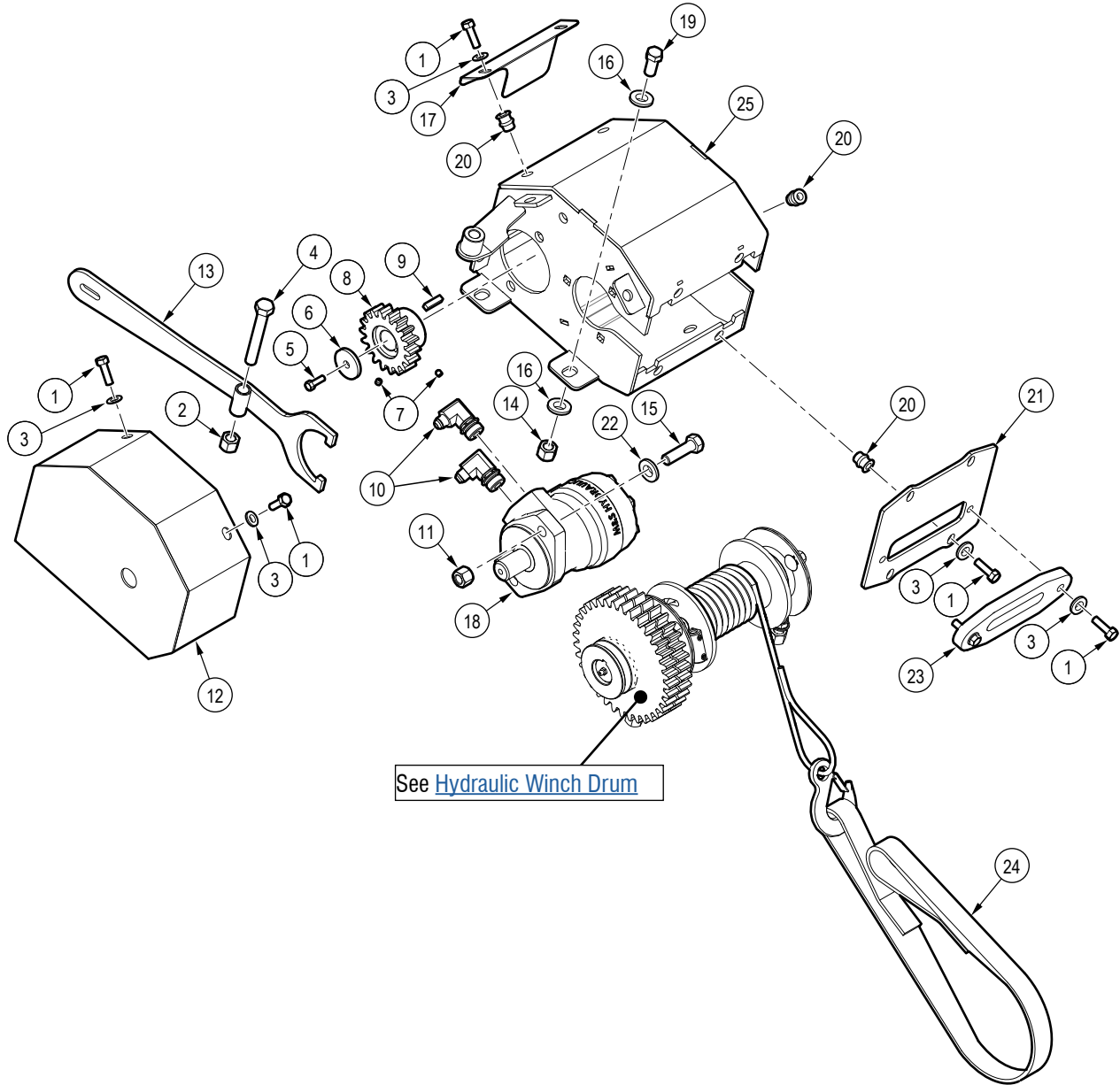

Item	Part number	Description	Quantity
1	Z71212	Hex Bolt, 5/16NC x 1-1/4"	11
2	Z72251	Hex Lock Nut, 1/2NC	11
3	Z73122G8	SAE Washer, 5/16" Grade 8	11
4	Z71535	Hex Bolt, 1/2NC x 3-1/2"	1
5	Z71107	Hex Bolt, 1/4NC x 3/4"	1
6	5081L114	Washer, Motor Shaft	1
7	Z74111	Set Screw, 1/4NC x 1/4"	2
8	5081M126	Drive Gear Hub	1
9	Z46533	Key, 1/4" x 1/4" x 1"	1
10	Z51656	Elbow 90, MJIC x MORB 0610	2
11	Z72251	Hex Lock Nut, 1/2NC	2
12	5081W111	Shield	1
13	5081W122	Handle, Winch Clutch	1

Item	Part number	Description	Quantity
14	Z73111G8	SAE Washer, 1/4" Grade 8	1
15	Z71517	Hex Bolt, 1/2NC x 1-3/4"	2
16	Z73151G8	SAE Washer, 1/2" Grade 8	10
17	5081L138	Guard	1
18	Z54109	Hydraulic Motor, 100CCR	1
19	Z71515	Hex Bolt, 1/2NC x 1-1/2"	4
20	Z72957	Rivet Nut, 5/16NC x 312	9
21	2251L071	Mount, Hawse Fairlead	1
22	Z73151G8	SAE Washer, 1/2" Grade 8	1
23	2251M003	Synthetic Fairlead	1
24	Z92405	Winching Strap, 1" x 5ft	1
25	2251W018	Housing, Winch	1

Hydraulic Winch Drum

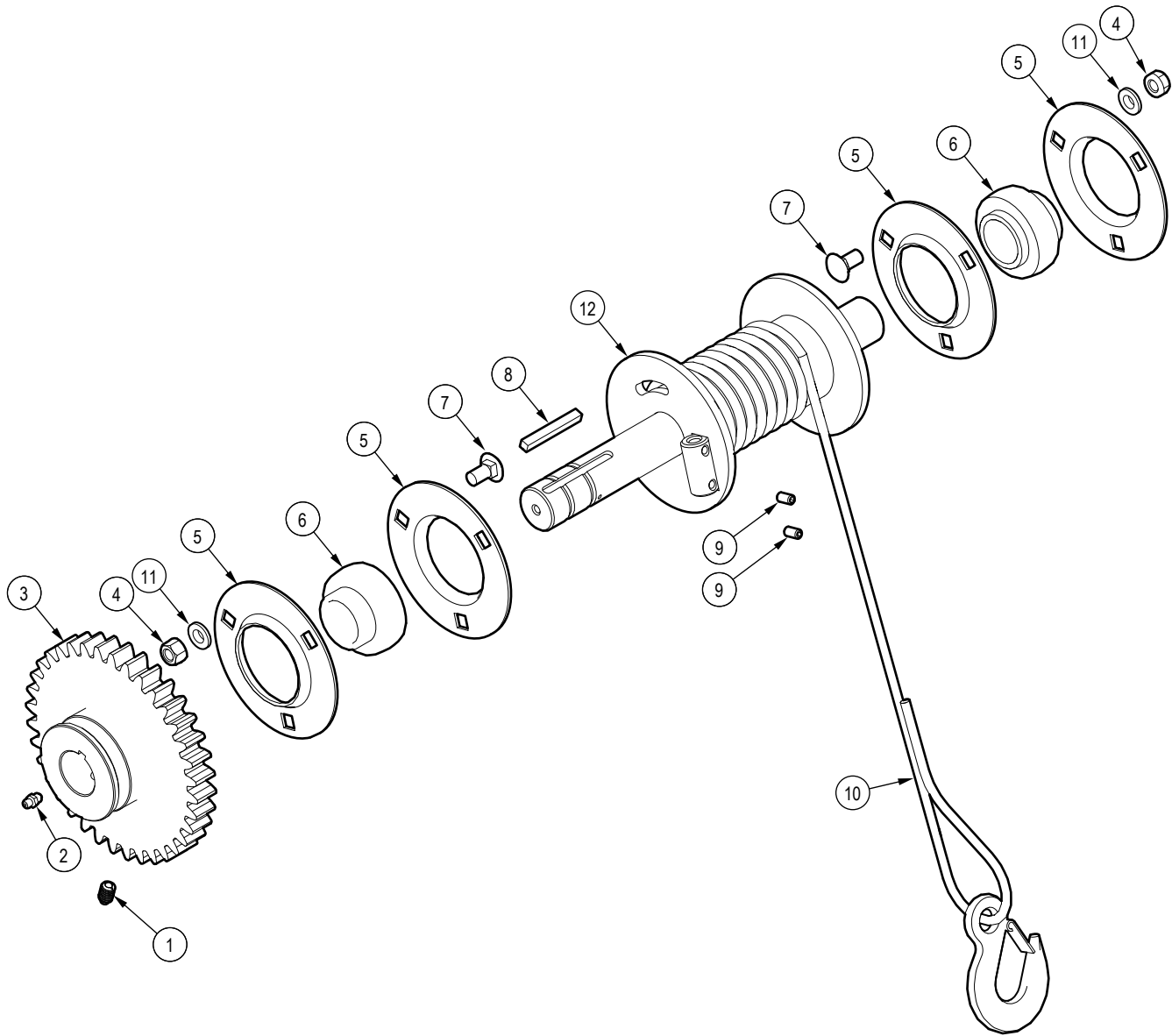

Item	Part number	Description	Quantity
1	Z34302	Spring Plunger, 3/8NC x 5/8" x 21 lbs	1
2	Z29202	Grease Fitting, 1/4NF	1
3	5081M125	Gear, Driven	1
4	Z72231	Hex Lock Nut, 3/8 NC	6
5	Z25301	3-Bolt Flange Bearing, PF206 x Flange Only	4
6	Z25207	Bearing Insert, UC206-20	2

Item	Part number	Description	Quantity
7	Z76231	Carriage Bolt, 3/8NC x 1"	6
8	Z46531	Key, 1/4" x 1/4" x 2"	1
9	Z74111	Set Screw, 1/4NC x 1/4"	2
10	Z92112	Synthetic Winch Rope, 1/4x50ft with Hook	1
11	Z73131G8	SAE Washer, 3/8" Grade 8	6
12	2251W019	Drum, Main Cable	1

Valve Assembly

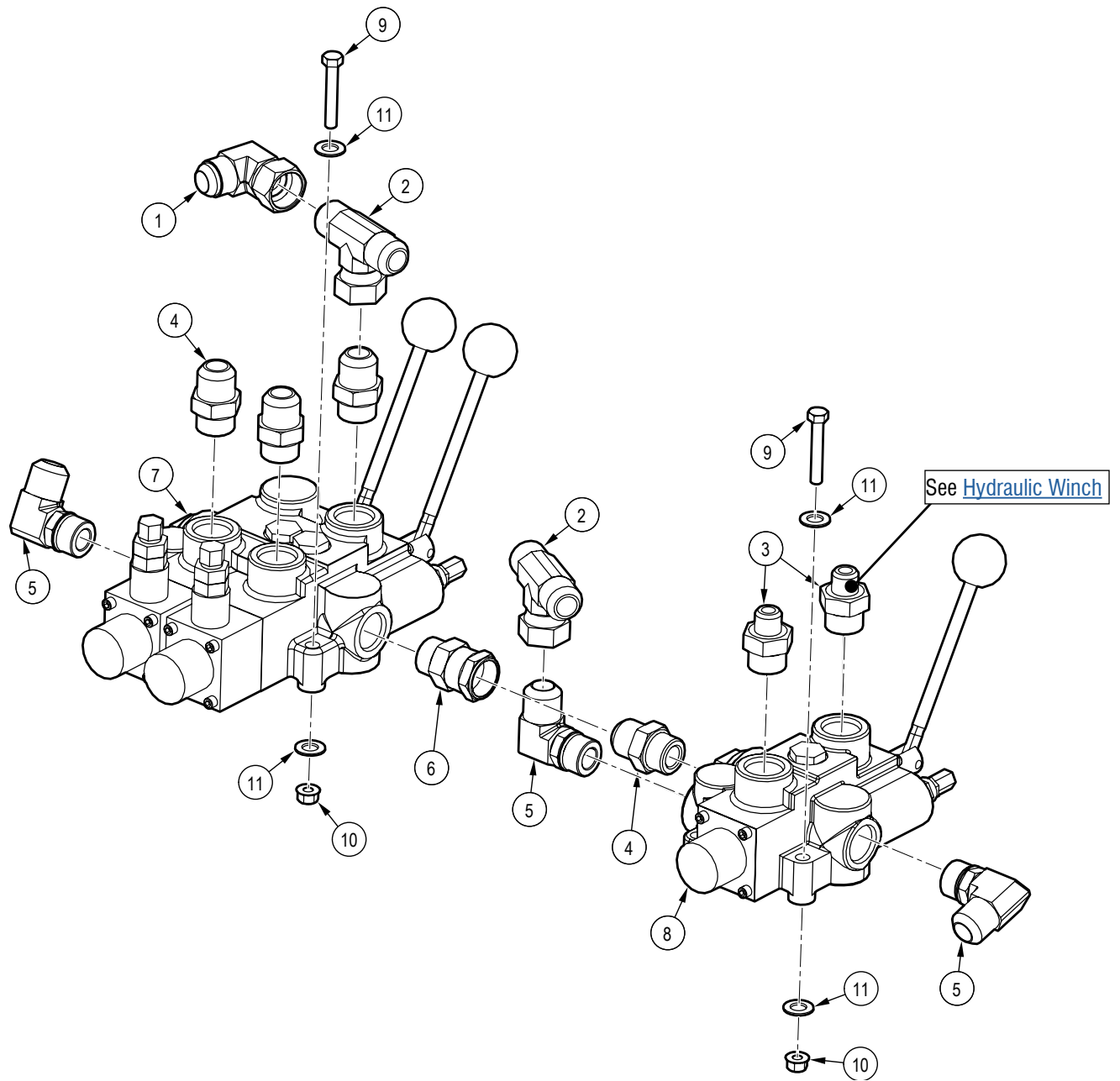

Item	Part number	Description	Quantity
1	Z51561	Elbow 90, MJIC x FJICX 1212	1
2	Z51596	Tee, MJIC x MJIC x FJICX 121212	2
3	Z516412	Straight, MJIC x MORB 0812	2
4	Z516414	Straight, MJIC x MORB 1212	4
5	Z516501	Elbow 90, MJIC x MORB 1212	3
6	Z51764	Straight, MORB x FJICX 1212	1

Item	Part number	Description	Quantity
7	Z56213	Auto-Cycle Valve, OC x 25GPM	1
8	Z56224	Single Spool Valve, PB Tandem SC x 30GPM	1
9	Z71220	Hex Bolt, 5/16NC x 2"	6
10	Z72221	Hex Lock Nut, 5/16NC	6
11	Z73122G8	SAE Washer, 5/16" Grade 8	12

Closed Center Plug

For tractors with a closed-center hydraulic circuit.

Replace port plug in the main control valve with item 1.

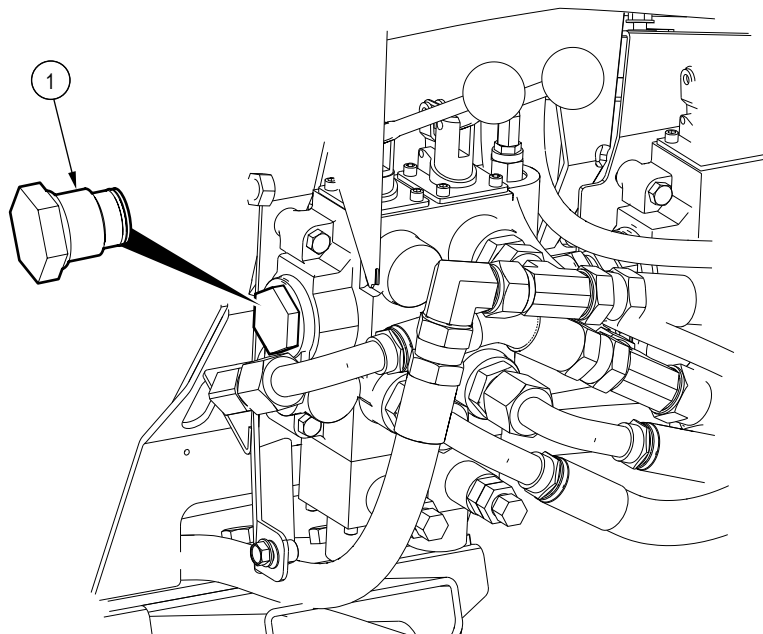

Item	Part number	Description	Quantity
1	Z56917	Closed Center Plug	1

Hydraulic Circuit

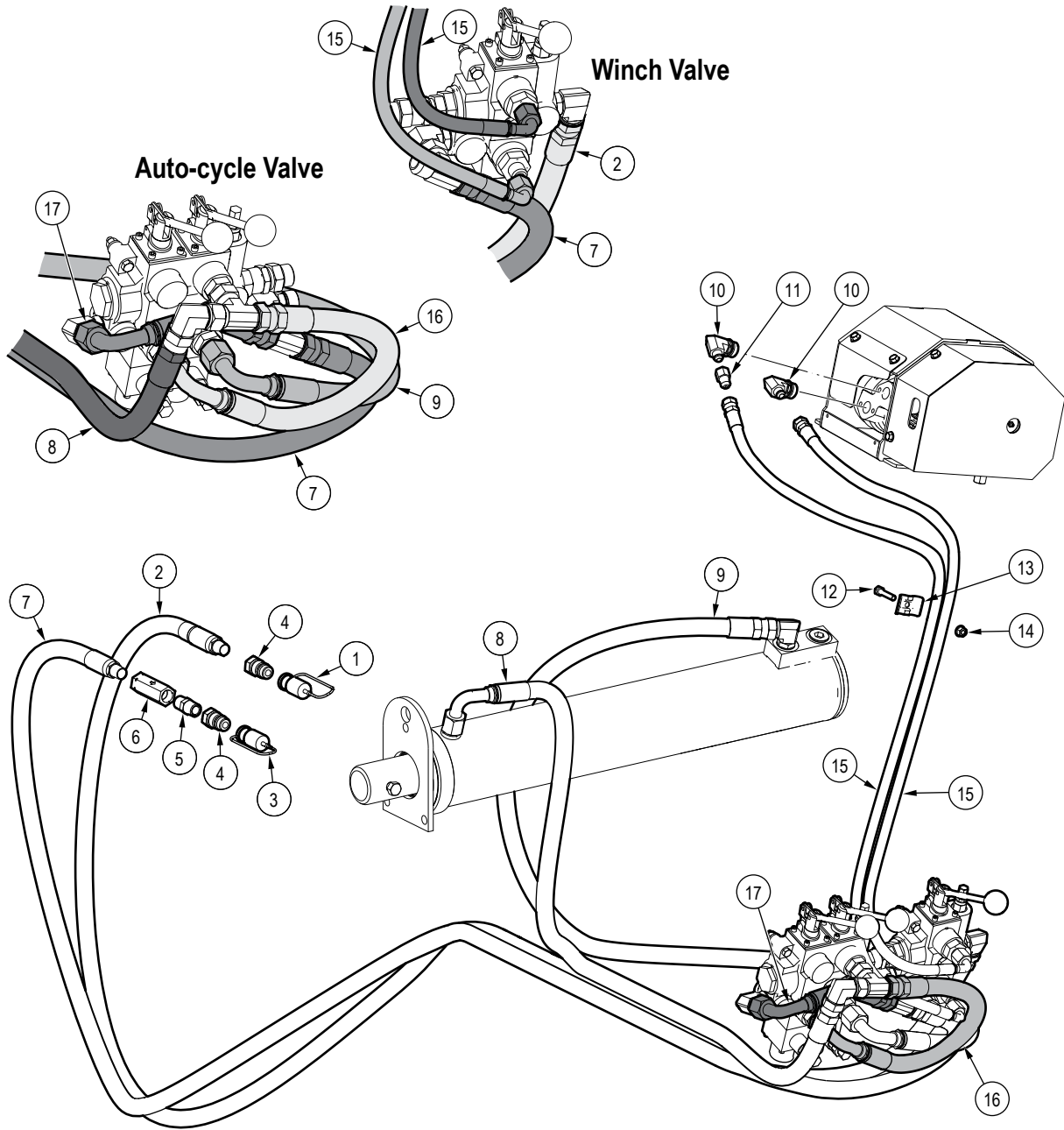

Item	Part number	Description	Quantity
1	Z52831	Nipple Cap, Red	1
2	2210F003	3/4" Hose FJIC12 x MP08 x 102"	1
3	Z52832	Nipple Cap, Black	1
4	Z51926	Quick Coupler, FP08 x M ISO 5675 IRV	2
5	Z51122	Straight, MP x MP 0808	1
6	Z56102	Check Valve, FP08 x 0PSI	1
7	2210F002	3/4" Hose, FJIC12 x MP08 x 102"	1
8	2210F001	3/4" Hose, FJIC12 x 90FJIC12 x 63"	1
9	2210F010	3/4" Hose, FJIC12 x 90FJIC12 x 66"	1

Item	Part number	Description	Quantity
10	Z51656	Elbow, 90° MJIC x MORB 0610	2
11	Z51944	Straight, FJIC x MJIC 0606 x 0.125" Orifice	1
12	Z71215	Hex Bolt, 5/16NC x 1-1/2"	1
13	2250L286	Hose Clamp, 2 x 3/8"	1
14	Z72221	Hex Lock Nut, 5/16NC	1
15	2251F007	3/8" Hose, FJIC06 x 90FJIC08 x 43"	2
16	2251F006	3/4" Hose, FJIC12 x 90FJIC12 x 17"	1
17	2251F008	3/4" Hose, FJIC12 x 90FJIC12 x 4-3/4"	1

Label Locations

IMPORTANT! If you replace a part that has a safety label on it, you must apply a new safety label. Immediately replace safety labels that are damaged, have been removed, or are illegible.

Contact your local Wallenstein Equipment dealer or distributor to order a safety label kit. Labels are not sold individually.

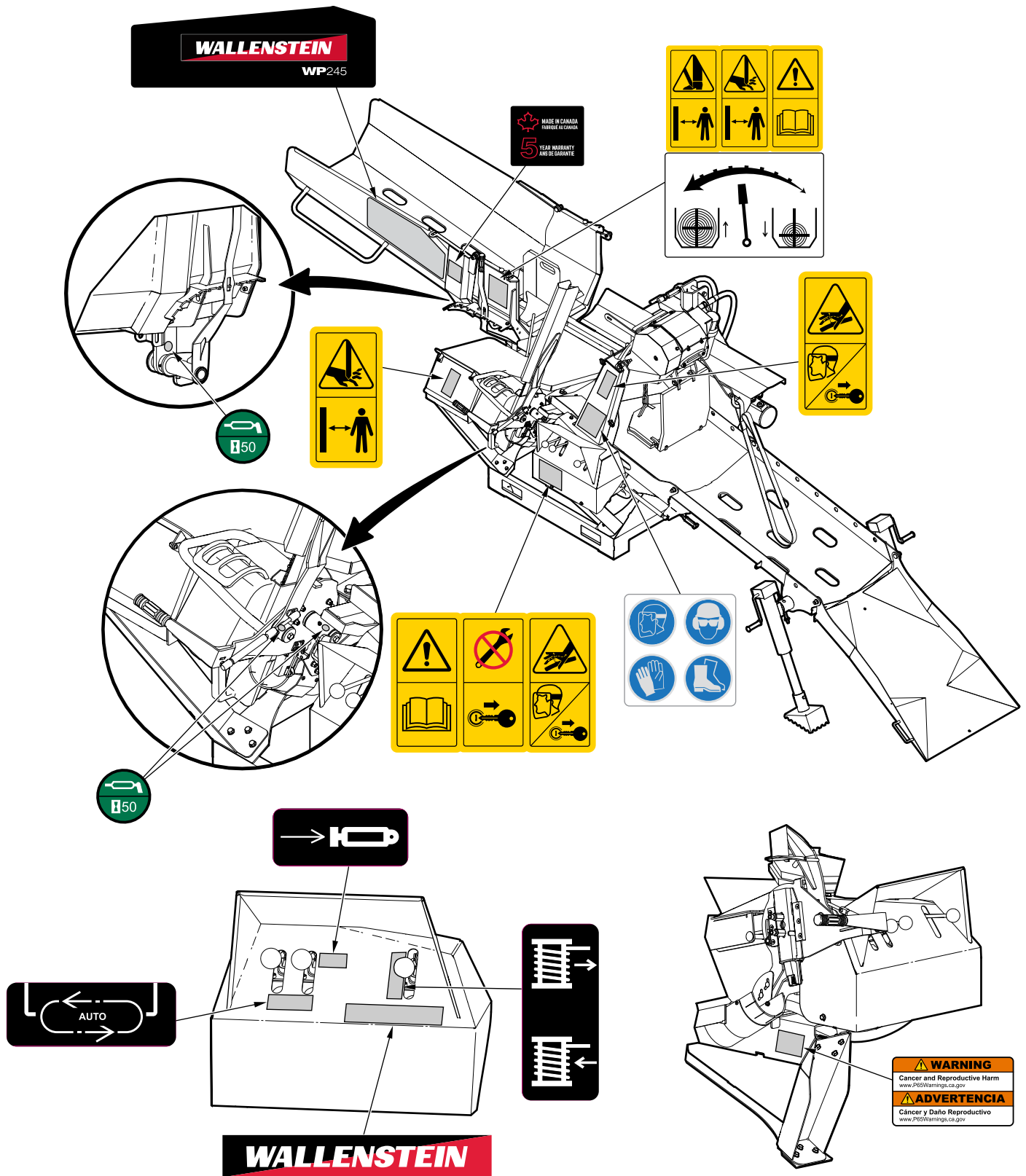

Label Locations

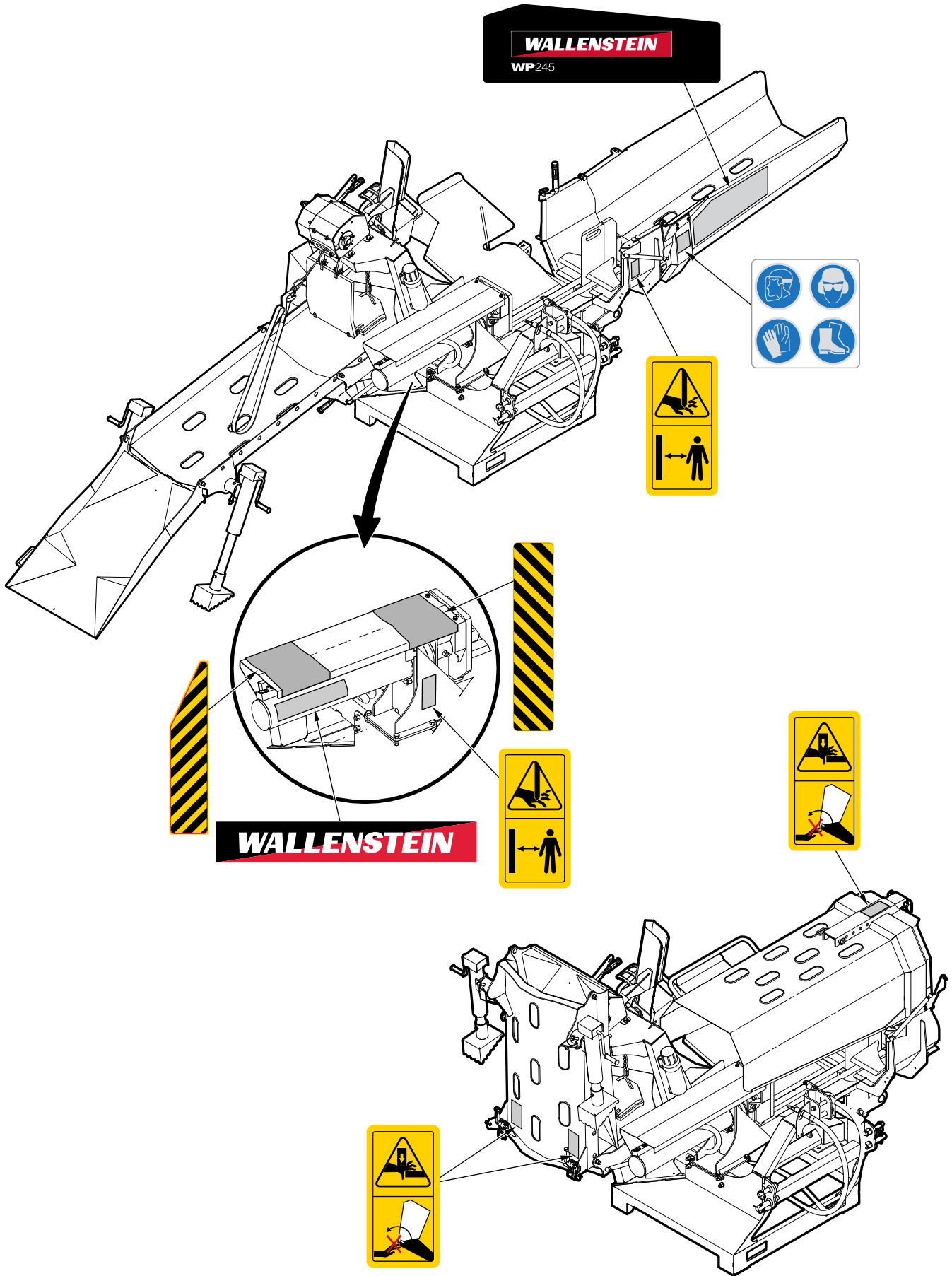

Label Locations

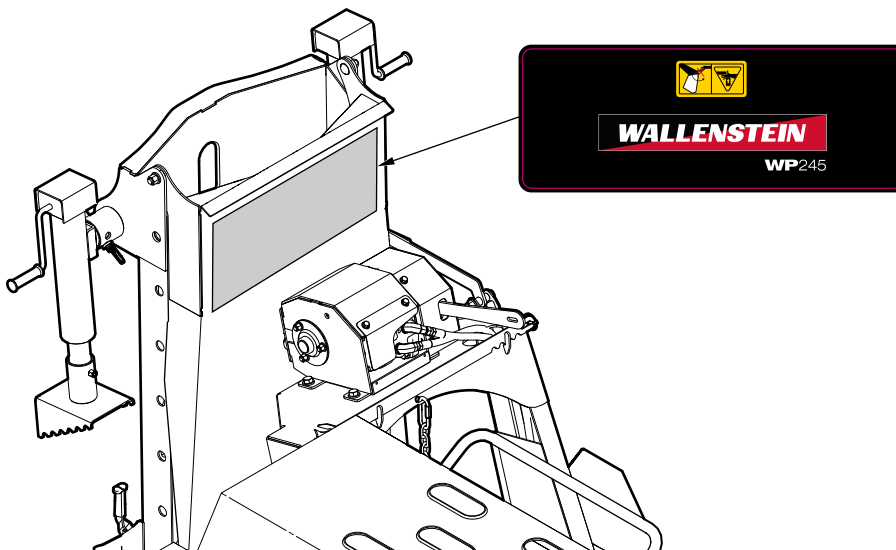
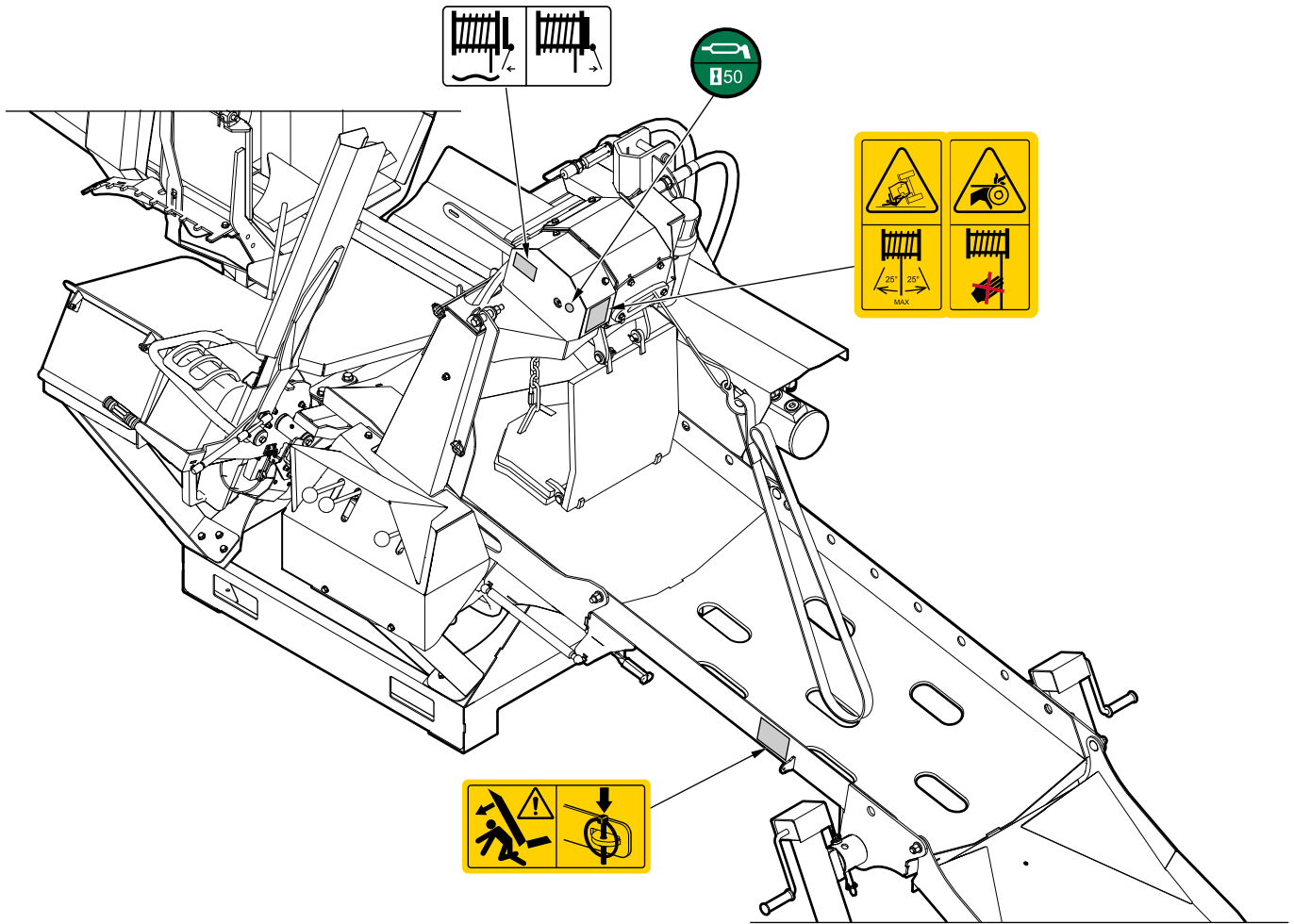

Accessories

For price and availability, contact your local Wallenstein dealer or distributor.

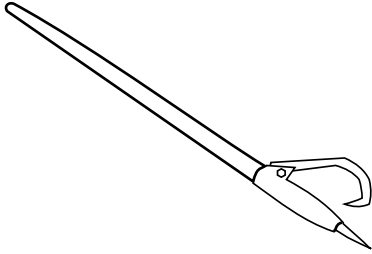

48" Log Peavey
Part number Z99001

Use the log peavey to feed your final log into the firewood processor. Also the ideal tool for gaining leverage for rolling heavy logs into position single stroke.

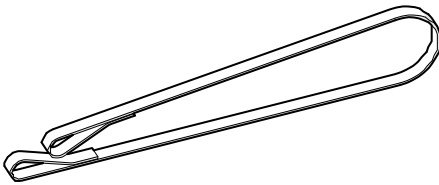

60" Winching Strap
Part number z92405

High strength nylon strap for winching logs onto the processor.

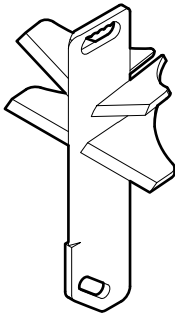

6-Way Wedge P01
Part number P01

Split logs into six pieces with a single stroke.

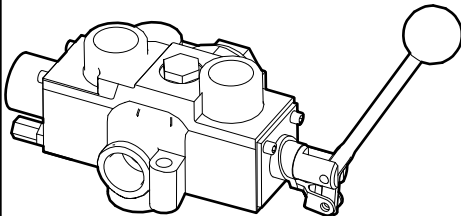

Closed Center Hydraulics
Part number Z56919

Closed center plug for WP200 models used on tractors with closed center hydraulics.

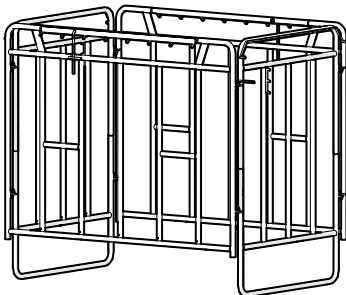

Firewood Mesh Bag Frame
Part number P500

Optimal skid size: 48" x 48"

Accessories

For price and availability, contact your local Wallenstein dealer or distributor.

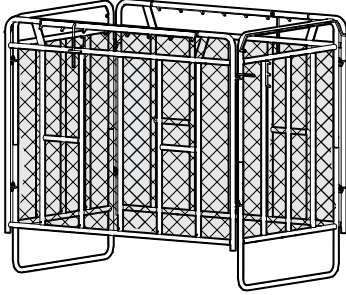

Firewood Mesh Bag Z99007
Part number Z99007

PTO Power Pack Use with the P500 frame and a pallet to have a log pile that is ready to go and easy to transport without having to manually stack it.

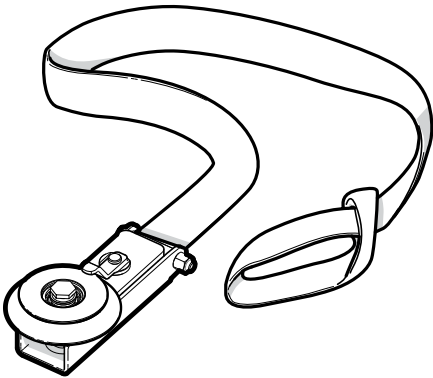

Self Releasing Directional Pulley
Part number 5089A100

Allows you to safely winch logs around corners, reducing damage to your logs. As the log approaches the pulley, it triggers a lever that automatically releases the cable from the pulley.

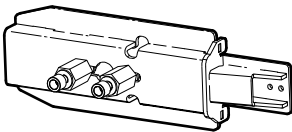

Spare Pivoting Chainsaw Adapter
Part number P212

Spare adapter kit for second chainsaw. For use with P201.

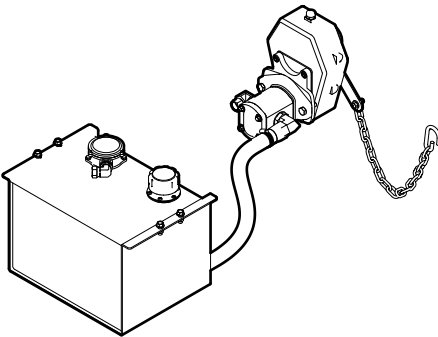

PTO Power Tank P300
Part number 2089A600 P300

PTO Power Pack

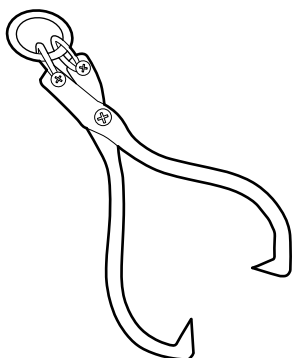

Logging Tongs
Part number Z99003

Opens to approx. 26" ..

Bolt Torque

IMPORTANT! If you replace hardware, use fasteners of the same grade.

IMPORTANT! The torque specifications in these tables are for non-greased or non-oiled threads. Do not grease or oil fastener threads unless otherwise indicated. When using a thread lock, increase the specified torque 5%.



Bolt grades are identified by the marks on the bolt head.

The bolt torque specification tables provide the correct torque settings for common bolts and capscrews. Tighten all bolts to the torque that is specified in the table, unless otherwise indicated. Check the bolt tightness periodically.

Imperial Bolt Torque Specifications

Bolt Diameter	Torque					
	SAE Gr. 2		SAE Gr. 5		SAE Gr. 8	
	lbf•ft	N•m	lbf•ft	N•m	lbf•ft	N•m
1/4 inch	6	8	9	12	12	17
5/16 inch	10	13	19	25	27	36
3/8 inch	20	27	33	45	45	63
7/16 inch	30	41	53	72	75	100
1/2 inch	45	61	80	110	115	155
9/16 inch	60	95	115	155	165	220
5/8 inch	95	128	160	215	220	305
3/4 inch	165	225	290	390	400	540
7/8 inch	170	230	420	570	650	880



SAE Gr. 2



SAE Gr. 5



SAE Gr. 8

Metric Bolt Torque Specifications

Bolt Diameter	Torque			
	Gr. 8.8		Gr. 10.9	
	lbf•ft	N•m	lbf•ft	N•m
M3	0.4	0.5	1.3	1.8
M4	2.2	3	3.3	4.5
M6	7	10	11	15
M8	18	25	26	35
M10	37	50	52	70
M12	66	90	92	125
M14	83	112	116	158
M16	166	225	229	310
M20	321	435	450	610
M30	1,103	1,495	1,550	2,100



8.8



10.9

Hydraulic Fitting Torque

Tighten flare-type tube fittings:

1. Check the flare and flare seat for defects that might cause leaks.
2. Align the tube with the fitting before tightening.
3. Hand-tighten the swivel nut until it is snug.
4. To prevent the tube from twisting, use two wrenches. Place one wrench on the connector body and tighten the swivel nut with the second wrench. Torque the fitting to the correct specification.

If a torque wrench is not available, use the flats from finger tight (FFFT) method.

Hydraulic Fitting Torque Specifications					
Tube size OD	Hex size across flats	Torque		Flats from finger tight	
		lbf•ft	N•m	Flats	Turns
3/16	7/16	6	8	2	1/6
1/4	9/16	11–12	15–17	2	1/6
5/16	5/8	14–16	19–22	2	1/6
3/8	11/16	20–22	27–30	1-1/4	1/6
1/2	7/8	44–48	59–65	1	1/6
5/8	1	50–58	68–79	1	1/6
3/4	1-1/4	79–88	107–119	1	1/8
1	1-5/8	117–125	158–170	1	1/8

Specifications are for non-lubricated connections.



MAKING WORK FEEL MORE LIKE PLAY™

WallensteinEquipment.com

