



# WX950 Trailer Log Splitter Parts Manual

Prior to S/N 295019



# Foreword

EMB Mfg. has prepared this parts manual to assist customers in ordering quality OEM replacement parts.

Proper and regular service and replacing old, worn or broken parts with the correct Wallenstein parts are essential to prolonging the life of your Wallenstein product. Please refer to this manual before ordering any replacement parts.

All information contained in this parts manual is based on the latest product specification available at the time of printing this manual. If your product differs from the specifications contained within this manual contact EMB Mfg. for information.

EMB reserves the right to alter specifications on their products at any time.

Reproduction of this parts manual of any kind is prohibited without prior written permission from EMB Mfg.

# Table of Contents

Main Parts	4
Sliding Wedge	6
Valve	7
Hub	8
Cylinder	9
Engine & Pump	10
4-Way Wedge (Optional)	11
Light Kit (Optional)	12
Decal Breakdown	14

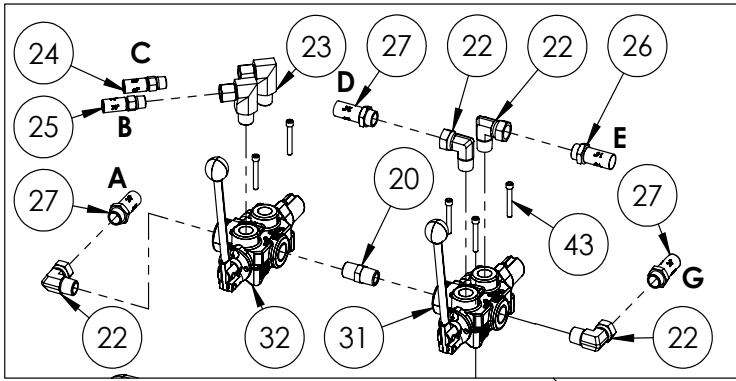

LETTERS DENOTE HOSE ROUTING CONNECTIONS

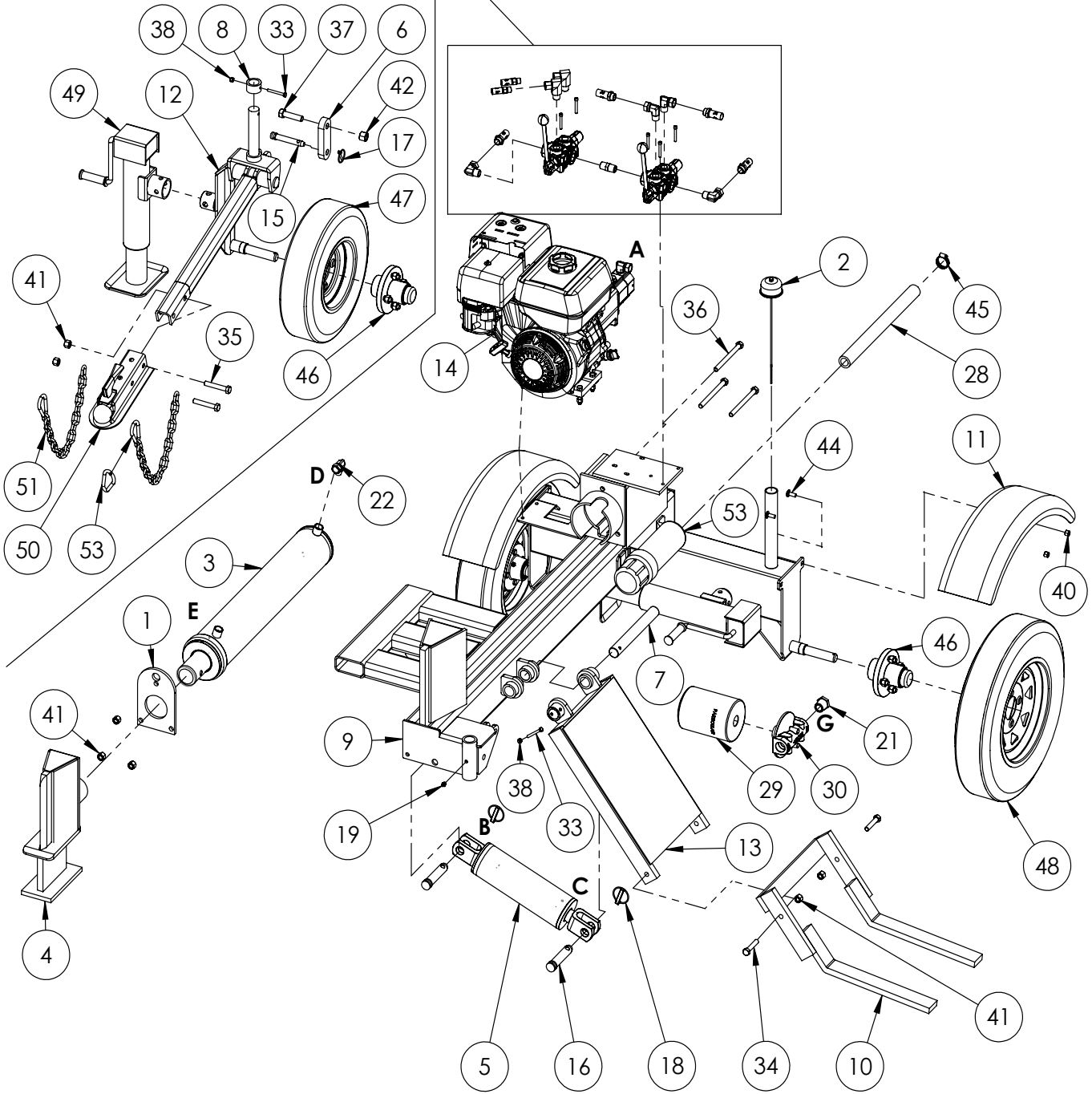

**WX950 PARTS BREAKDOWN**

ITEM	PART NO.	DESCRIPTION	QTY
1	2032S213	Plate, Cylinder Retaining	1
2	2054A402	Breather cap dipstick	1
3	2055C501	Cylinder, 4-1/2 x 24 x 2-1/2	1
4	2058A802	Wedge for WX950	1
5	2058C801	Cylinder, 3-1/2 x 8 X 1-1/2	1
6	2058L809	Lock Link	1
7	2058M815	Pin, Shelf Pivot	1
8	2058M819	Bushing, Pivot with Hole	1
9	2058W805	Weldment, Main Trailer	1
10	2058W810	Weldment, WX950 Log Arm	1
11	2058W811	Weldment, Fender	2
12	2058W812	Weldment, Front Tire	1
13	2058W813	Weldment, Lift Shelf	1
14	2061A103	Assy, 9hp Engine to 16gpm Pump	1
15	Z11111	Toplink Pin 5/8 x 2-3/4	1
16	Z11141	Toplink Pin 1 x 3-3/16	2
17	Z12110	Latch Pin 3/16	1
18	Z12140	Latch Pin 7/16	2
19	Z29201	Grease Fitting, 1/8NPT	2
20	Z51122	Nipple, MP x MP 0808	1
21	Z51223	Reducer, MP x FP 1608	1
22	Z51331	Elbow 90 MP x FPX 0808	5
23	Z51332	Elbow 90 MP x FPX 0806	2
24	Z52233	3/8 Hose, MP06 x MP06 x 63"	1
25	Z52234	3/8 Hose, MP06 x MP06 x 70"	1
26	Z52301	1/2 Hose MP08 x MP08 x 16"	1
27	Z52305	1/2 Hose, MP08 x MP08 x 24"	3
28	Z52404	Suction Hose, 1" x 18"	1
29	Z55303	Oil Filter - 1" - Particulate	1
30	Z55304	Filter Cap, FP16 x FP16	1
31	Z56209	Valve, Single Function Detent	1
32	Z56211	Valve, Single Function	1
33	Z71122	Hex Bolt 1/4NC x 2-1/4	2
34	Z71525	Hex Bolt 1/2NC x 2-1/2	2
35	Z71530	Hex Bolt 1/2NC x 3	2
36	Z71560	Hex Bolt 1/2NC x 6	3
37	Z71625	Hex Bolt, 5/8NC x 2-1/2	1
38	Z72111	Hex Lock Nut 1/4NC	8
39	Z72221	Hex Lock Nut 5/16NC	1
40	Z72231	Hex Lock Nut 3/8NC	4
41	Z72251	Hex Lock Nut 1/2NC	7
42	Z72261	Hex Lock Nut 5/8NC	1
43	Z75114	SHCS, 1/4NC x 1-3/4	6
44	Z76231	Carriage Bolt 3/8NC x 1	4
45	Z79401	Hose Clamp, #16	2
46	Z91202	Assembly, 1000# 4-Bolt Hub	3
47	Z91301	4.80-8 LRB SportTrail	1
48	Z91302	5.30-12 LRB SportTrail 4 Spoked	2
49	Z91512	Side-Wind 10" Swivel Jack	1
50	Z91614	2" Hitch Coupler	1
51	Z92303	Safety Chain 1/4 x 2'	2
52	Z92303-2	Safety Snap	2
53	Z96503	Manual Tube 3-1/2 Short	1

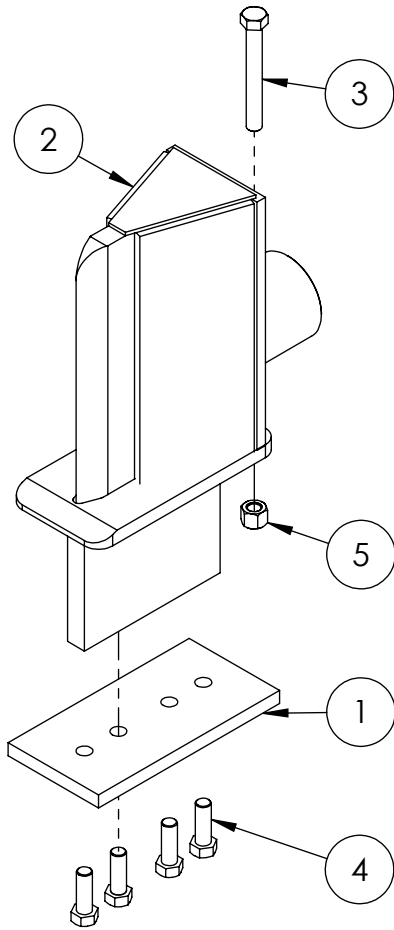

**2058A802 SLIDING WEDGE PARTS BREAKDOWN**

ITEM	PART NO.	Description	QTY.
1	2014S414	Plate, Sliding Wedge Capture	1
2	2058W803	Wedge, Large Sliding	1
3	Z71540	Hex Bolt 1/2NC x 4	1
4	Z71576	Hex Bolt 1/2NF x 1-1/2	4
5	Z72251	Hex Lock Nut 1/2NC	1

# Z56203 Valve Breakdown

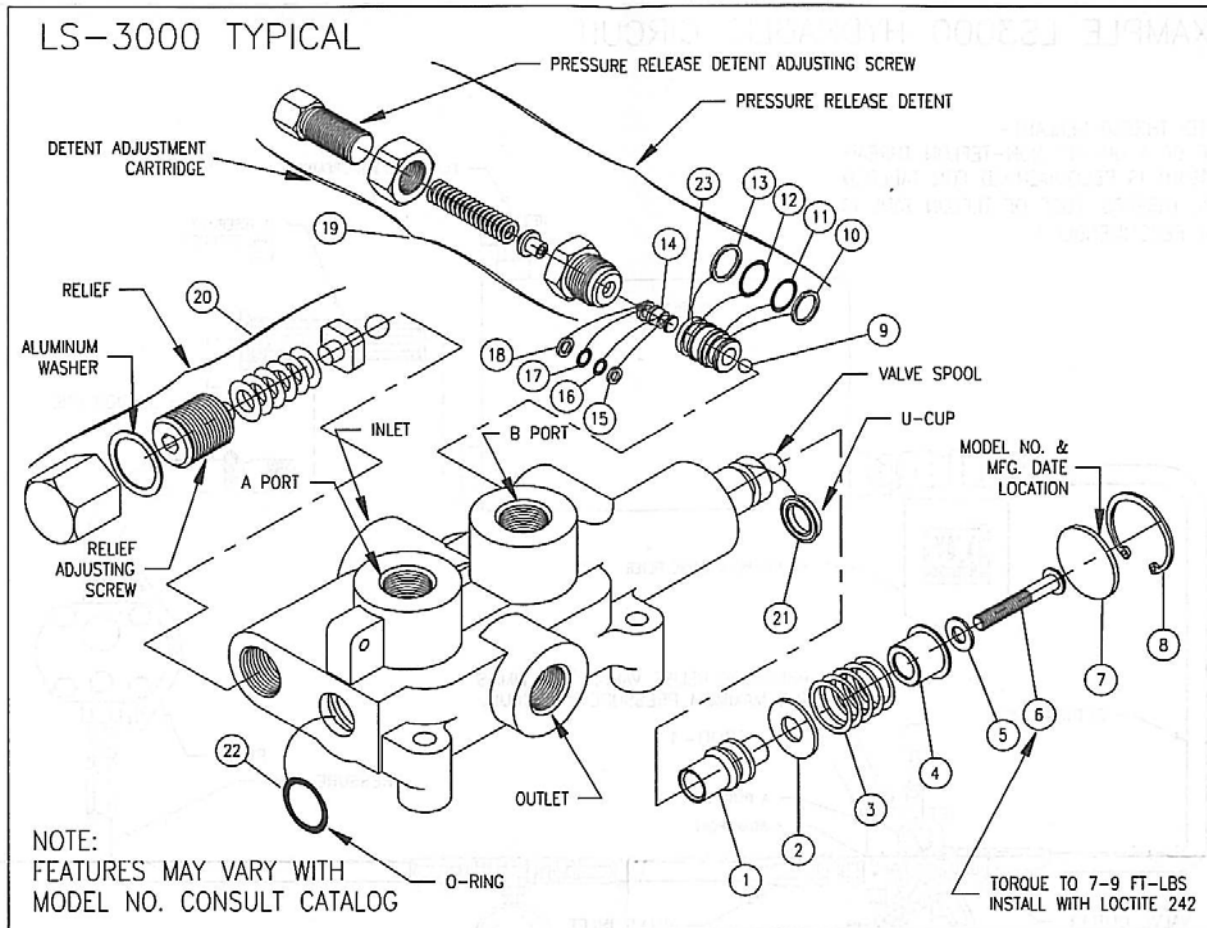

**PLEASE NOTE:**  
BEFORE REMOVING VALVE SPOOL OR SPOOL SLEEVE REMOVE DETENT ADJUSTING CART., DETENT PISTON AND STEEL BALL. INSTALL SPOOL AND SPOOL SLEEVE BEFORE REINSTALLING STEEL BALL.

## LS-3000 KITS AND CARTRIDGES

**PRESSURE RELEASE DETENT**  
This feature provides a pressure release detent for the spool 'out' (handle in) position. When the spool is manually placed in the detent position oil is directed to the 'B' work port (the port away from the handle). When the pressure in the 'B' port reaches a preset level the detent will release and the spool will center. The factory setting is 1400 psi. The detent release pressure is adjustable by loosening the jam nut and turning the adjusting screw. Turning the adjusting screw clockwise will increase the detent release pressure and counterclockwise will decrease the detent release pressure. NOTE: if the detent release pressure is set too high the spool will not center, if the pressure is too low the detent will not hold. If cap screw item 6 becomes loose detent will not function properly.

**RELIEF VALVE**  
An adjustable ball spring relief valve is standard on all LS-3000 valves. The standard factory setting is 2250 psi @ 3 gpm and 120°F. Other settings can be specified. The relief pressure is adjusted by removing acorn nut, and turning the adjusting screw. Turning the adjusting screw clockwise will increase the pressure and counterclockwise will decrease the pressure (a pressure gauge must be installed in the inlet line whenever the relief pressure is adjusted). Do not backout adjusting screw to the point it falls out.

ITEM	QTY	PART NO.	DESCRIPTION
1	1	670700019	DETENT SLEEVE
2	1	670500033	WASHER
3	1	670300020	SPRING
4	1	671400010	STOP CUP
5	1	670500026	WASHER
6	1	220000953	CAP SCREW
7	1	670500032	SPACER
8	1	230001125	SNAP RING
9	1	230009009	STEEL BALL
10	1	240019013	BACK-UP WASHER
11	1	240000013	O-RING
12	1	240000014	O-RING
13	1	240019014	BACK-UP WASHER
14	1	671100011	PISTON
15	1	240019007	BACK-UP WASHER
16	1	240016067	O-RING
17	1	240016068	O-RING
18	1	240019008	BACK-UP WASHER
19	1	660330002	DETENT ADJUSTING CART.
20	1	660125004	RELIEF KIT
21	1	240016086	U-CUP
22	1	240000210	O-RING
23	1	671100012	PISTON SLEEVE
		660530001	LS-3000 SEAL KIT
		660125004	RELIEF KIT
		660330002	DETENT ADJUSTING CART.
		660130007	PRESSURE RELEASE DETENT KIT
		660130001	COMPLETE HANDLE KIT

**⚠ WARNING: OVERPRESSURE MAY CAUSE SUDDEN AND UNEXPECTED FAILURE OF A COMPONENT IN THE HYDRAULIC SYSTEM RESULTING IN SERIOUS PERSONAL INJURY. ALWAYS USE A GAUGE WHEN ADJUSTING A RELIEF VALVE.**

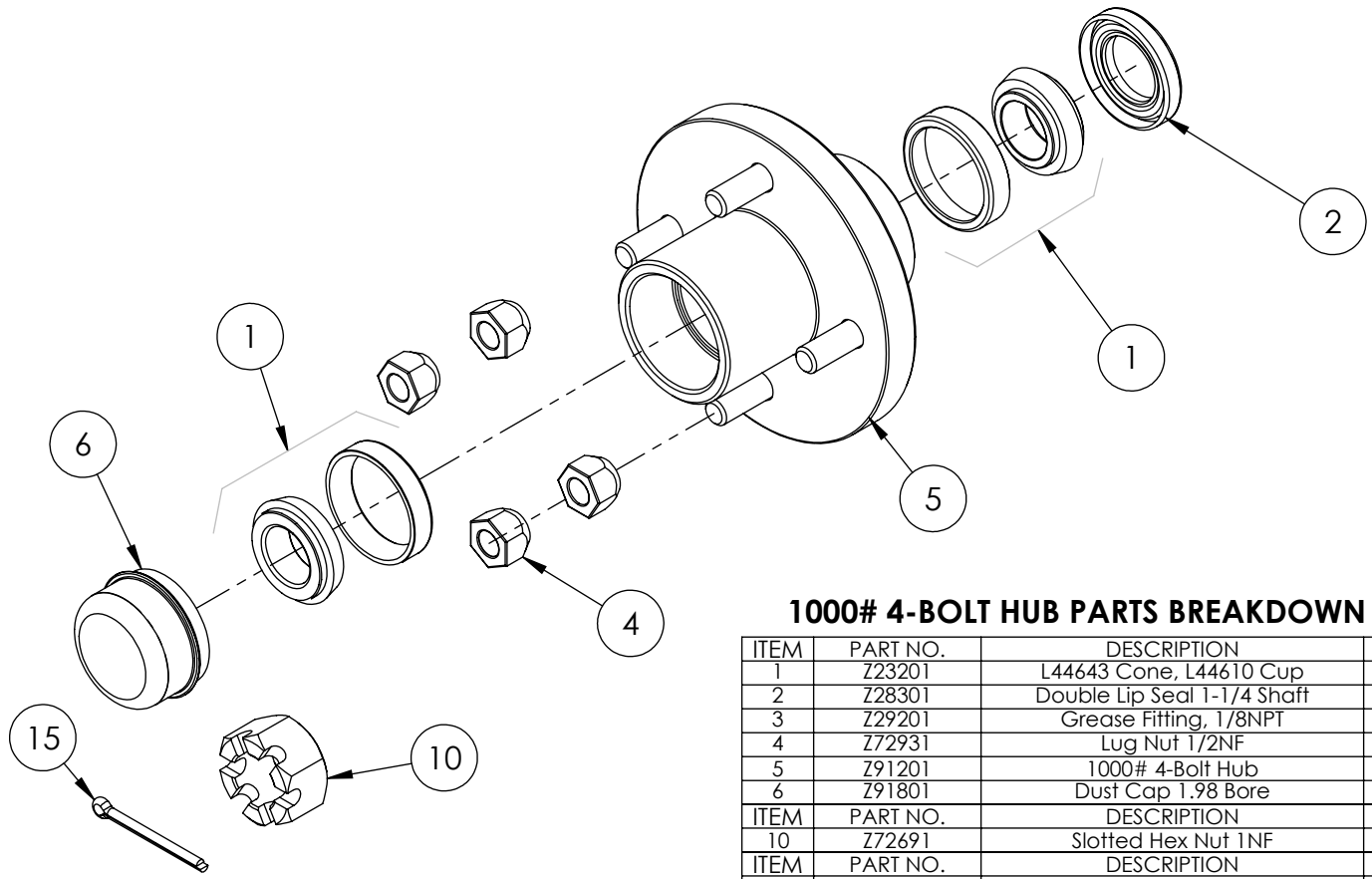

**1000# 4-BOLT HUB PARTS BREAKDOWN**

ITEM	PART NO.	DESCRIPTION	QTY
1	Z23201	L44643 Cone, L44610 Cup	2
2	Z28301	Double Lip Seal 1-1/4 Shaft	1
3	Z29201	Grease Fitting, 1/8NPT	1
4	Z72931	Lug Nut 1/2NF	4
5	Z91201	1000# 4-Bolt Hub	1
6	Z91801	Dust Cap 1.98 Bore	1
ITEM	PART NO.	DESCRIPTION	QTY
10	Z72691	Slotted Hex Nut 1NF	1
ITEM	PART NO.	DESCRIPTION	QTY
15	Z12322	Cotter Pin 3/16 X 2	1



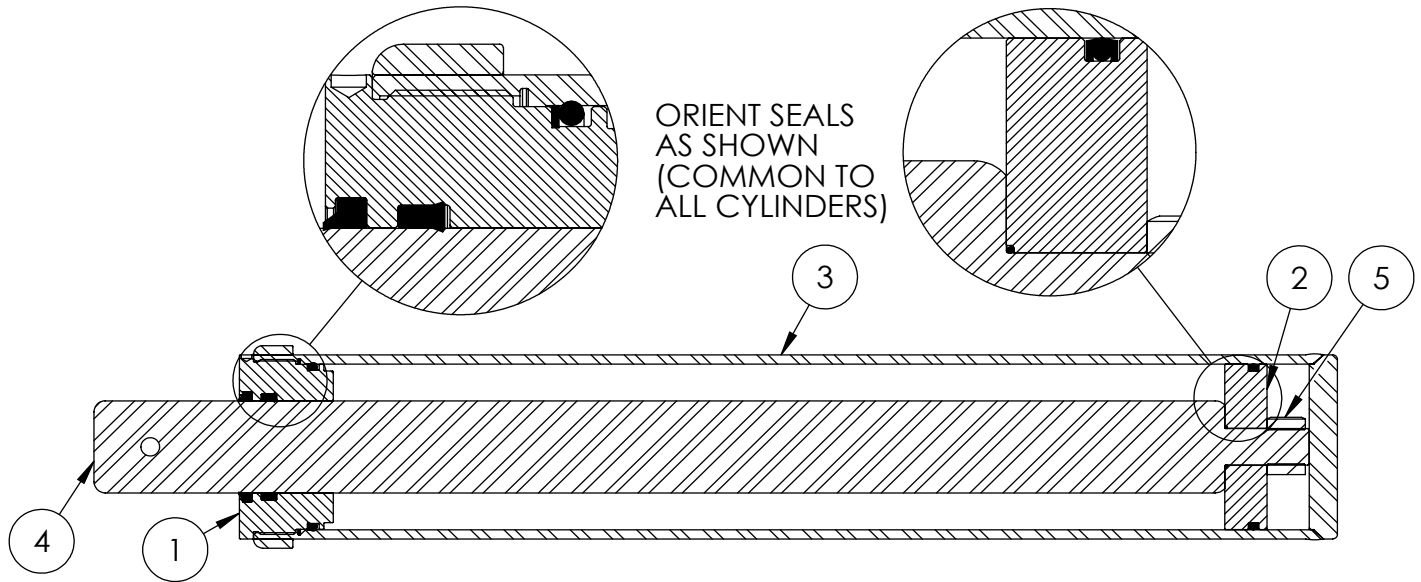

### 4-1/2" WOODSPLITTER CYLINDER PARTS BREAKDOWN

ITEM	PART NO.	DESCRIPTION	QTY
1	G450-250SA	4-1/2" Bore x 2-1/2" Rod Gland With Seals	1
2	P100-450SA	4-1/2" Bore Piston With Seals	1
3	2055C5014	Barrel, 4-1/2"	1
4	2055C5012	Rod, 2-1/2x 1	1
5	Z72292G8	Hex Lock Nut 1NF Grade 8	1
6	SLK-4525	Seal Kit, 4-1/2 x 2-1/2	1

**2061A102 9hp ENGINE / PUMP ASSEMBLY PARTS**

ITEM	PART NO.	Description	QTY.
1	Z46404	Shaft Coupler L095 x 1	1
2	Z46405	Coupler Spider L095	1
3	Z46409	Shaft Coupler L095 x 1/2	1
4	Z46533	Key 1/4 x 1/4 x 1	1
5	Z46592	Woodruff Key, 1/8 x 1/2	1
6	Z47136	Honda 9hp Engine	1
7	Z51383	Elbow 90 ORB x FPX 0808	1
8	Z53202	Pump, Two-Stage 16gpm	1
9	Z53802	Pump Mounting, PM-9	1
10	Z71255	Hex Bolt, 5/16NC x 5-1/2	2
11	Z71274	Hex Bolt, 5/16NF x 1	4
12	Z71320	Hex Bolt 3/8NC x 2	4
13	Z72231	Hex Lock Nut 3/8NC	4

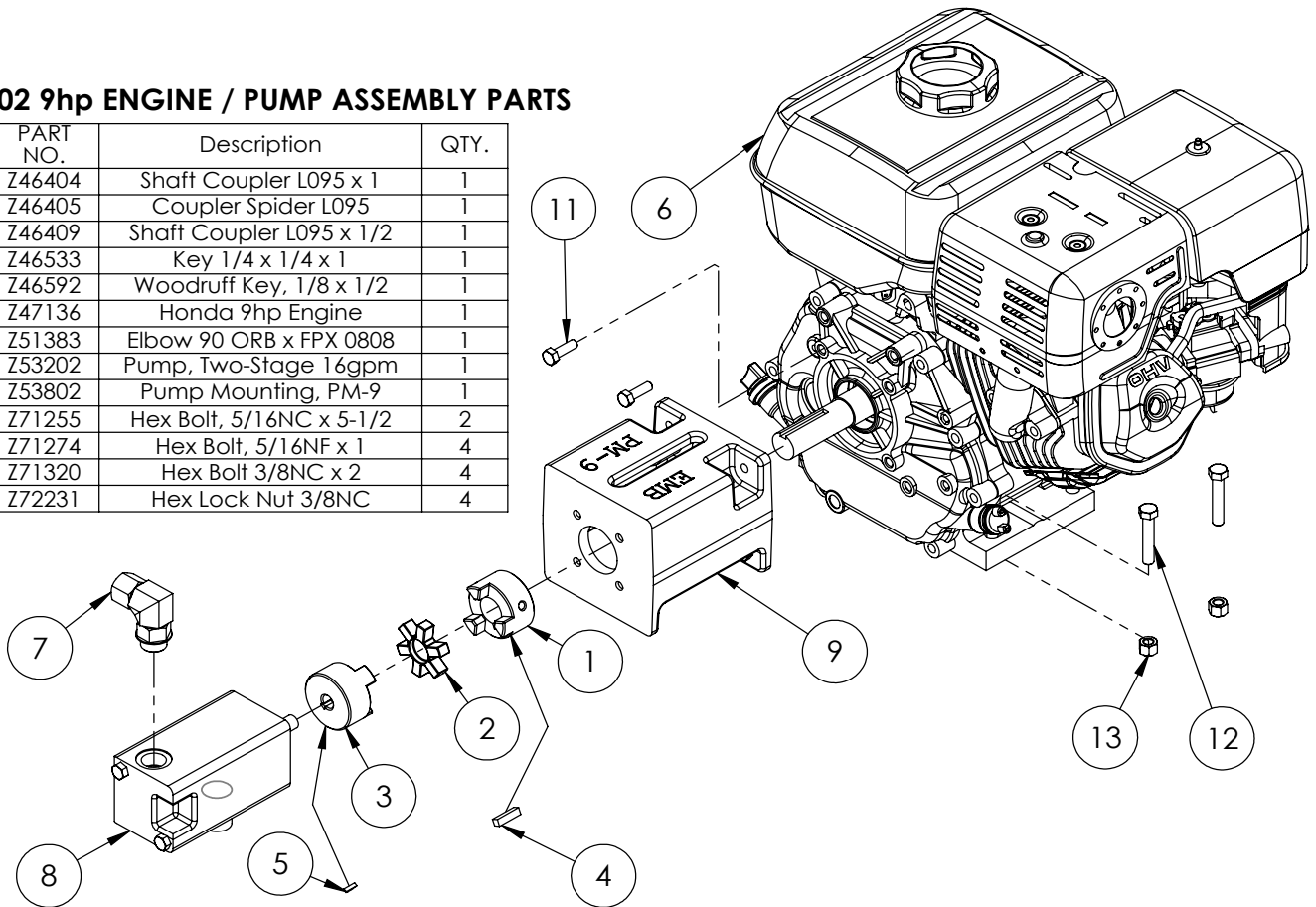

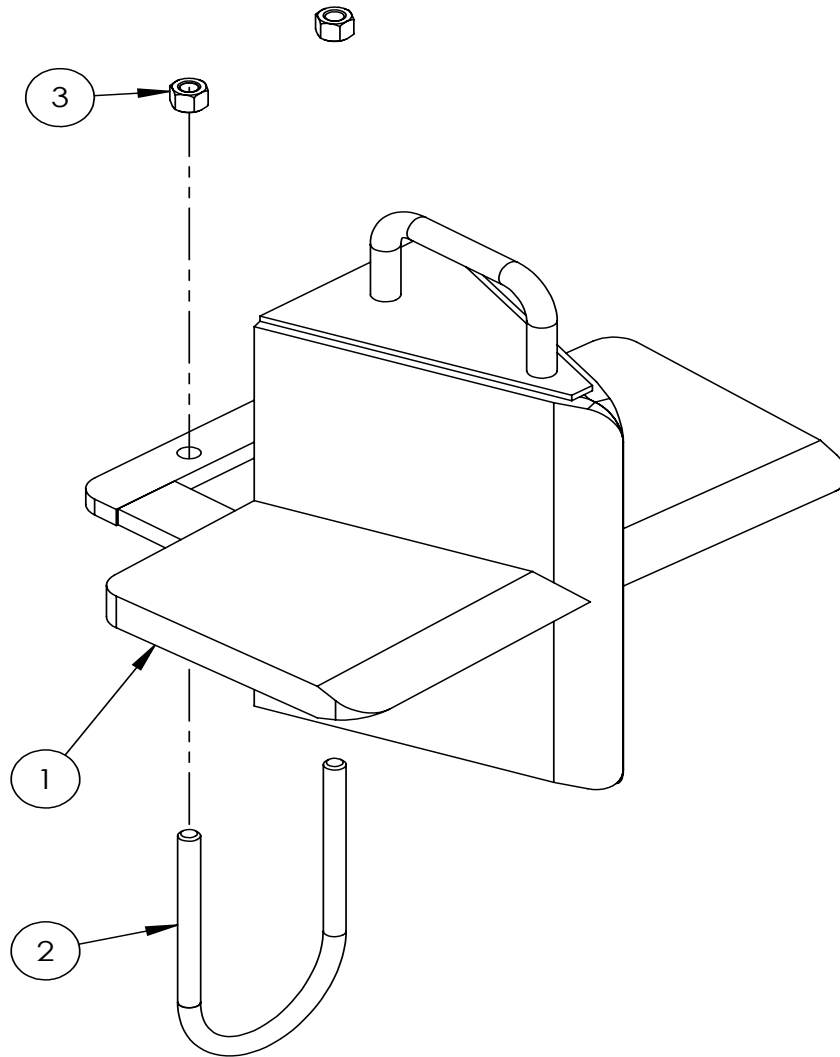

### W4130 4-Way Wedge (Optional)

ITEM	PART NO.	DESCRIPTION	QTY
1	2082W301	Weldment, Main 4-Way	1
2	2082S307	U-Bolt, 3 x 4	1
3	Z72231	Hex Lock Nut 3/8NC	2

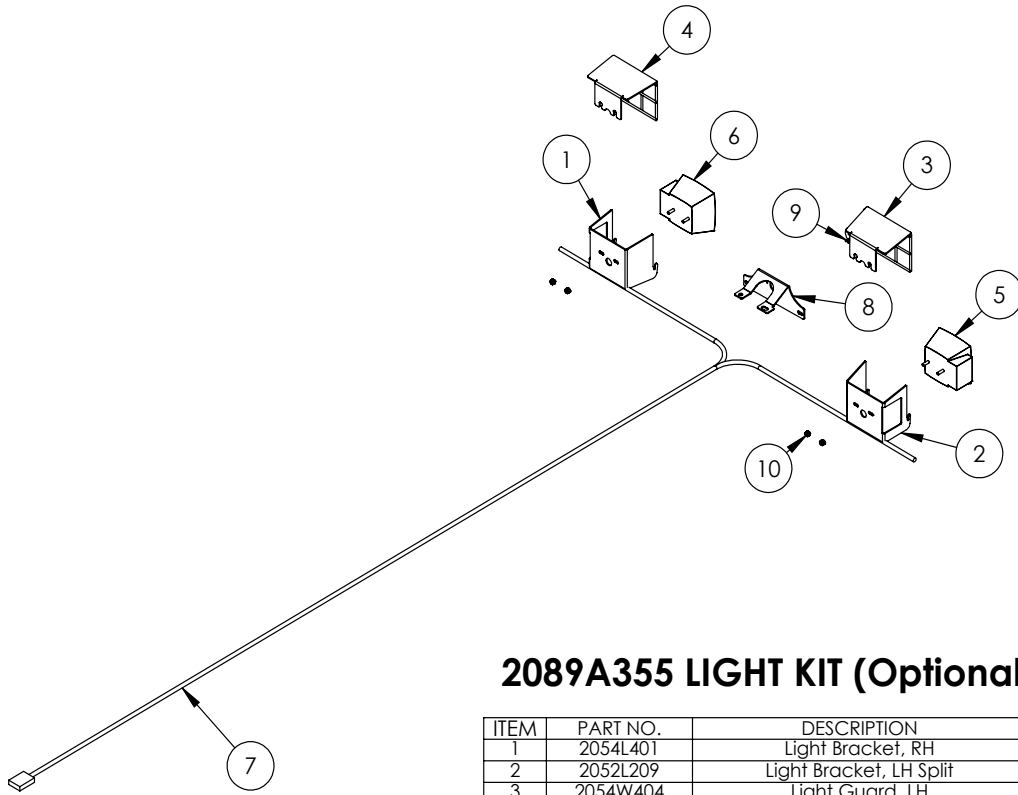

**2089A355 LIGHT KIT (Optional)**

ITEM	PART NO.	DESCRIPTION	QTY
1	2054L401	Light Bracket, RH	1
2	2052L209	Light Bracket, LH Split	1
3	2054W404	Light Guard, LH	1
4	2054W403	Light Guard, RH	1
5	Z61106	Stop, Turn, Tail Light LH	1
6	Z61107	Stop, Turn, Tail Light RH	1
7	Z62102	10' Wishbone Trailer Harness	1
8	2052L210	License Bracket	1
9	Z61301	License Lamp	1
10	Z72941	Serrated Washer Nut 1/4NC	4

# WX TRAILER SPLITTER WIRING

KEY	
Bl	- BLUE
Br	- BROWN
Gr	- GREEN
Rd	- RED
Yl	- YELLOW
Bk	- BLACK
Wh	- WHITE

## RIGHT SIDE

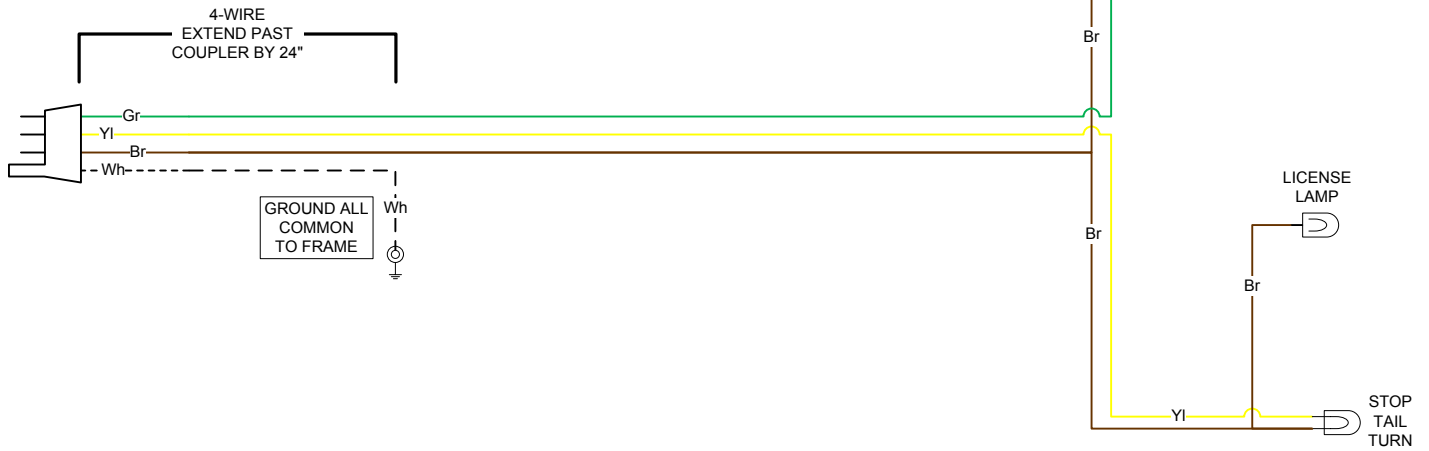

## LEFT SIDE

## HORIZONTAL LOG SPLITTER DECAL BREAKDOWN

ITEM	PART NO.	DESCRIPTION	QTY
1	Z94039	CAUTION - Read Manual	1
2	Z94040	WARNING - Moving Wedge	2
3	Z94067	Clear Guide	2
4	Z94056	Wallenstein	2
5	Z94019	Made in Canada	2
6	Z94066	Apply Oil or Grease	1

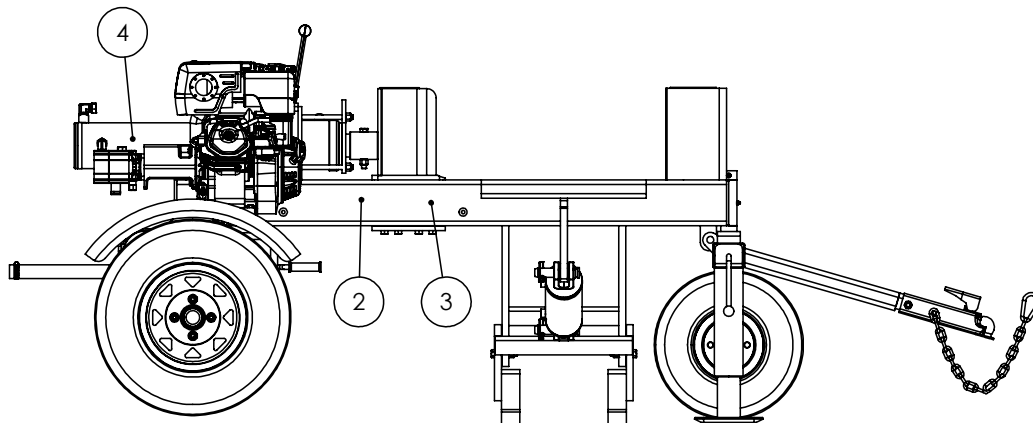
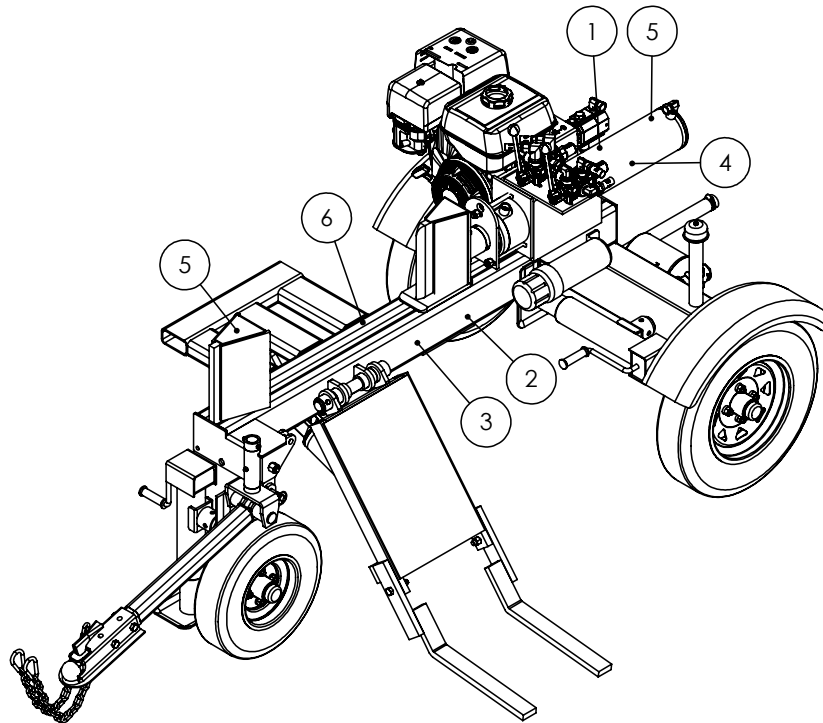

## Trailer Splitter Decals

Z94056



Z94067



Z94019



Z94066

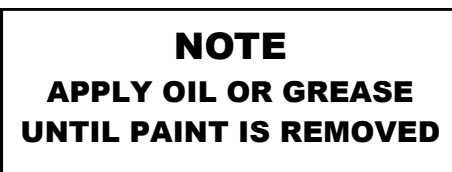

Z94039

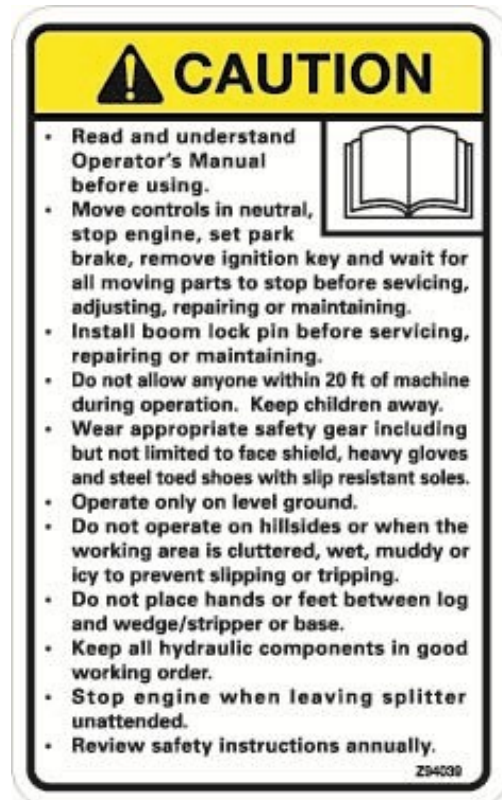

Z94040





**WALLENSTEIN Products Manufactured by:**

**EMB MFG Inc.**

4144 Boomer Line  
St. Clements, Ontario  
Canada N0B 2M0  
Phone: 1-877-695-9283  
Fax: 519-699-4146  
[www.embmfg.com](http://www.embmfg.com)