



EMB Manufacturing Inc.
4144 Boomer Line · St. Clements, On · N0B 2M0 · Canada
Ph: (519) 699-9283 · Fax: (519) 699-4146
www.wallensteinequipment.com

GX920XT Backhoe

Parts Manual

Starting with S/N's
3920XT221 and on

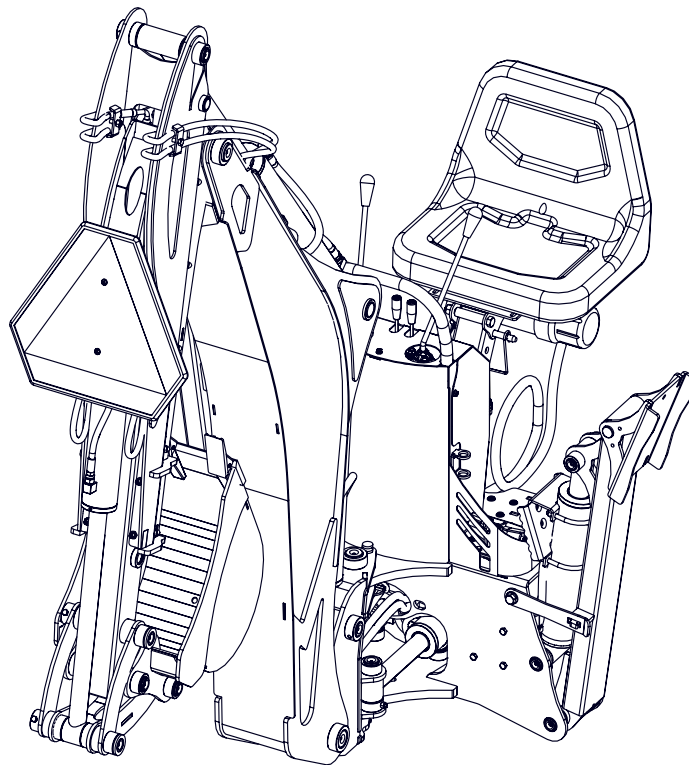

Refer to the operators
manual for safe
operation and
maintenance



3014T000 GX920XT RevD1 Parts Manual.221215
200617

Foreword

EMB Mfg. has prepared this parts manual to assist customers in ordering quality OEM replacement parts.

Proper and regular service and replacing old, worn or broken parts with the correct OEM parts are essential to prolonging the life of your EMB product. Please refer to this manual before ordering any replacement parts.

All information contained in this parts manual is based on the latest product specification available at the time of printing this manual. If your product differs from the specifications contained within this manual contact EMB Mfg. for information.

EMB reserves the right to alter specifications on their products at any time.

Reproduction of this parts manual of any kind is prohibited without prior written permission from EMB Mfg.

For parts and information please contact your dealer. If your dealer is no longer available please go to our website: <http://www.wallensteinequipment.com> and click on "FIND A DEALER NEAR YOU" for information on a local dealer.

Table of Contents Page

Bolt Torque.....	4
Hydraulic Fitting Torque	5
Main Frame Assembly	6
Stabilizer Leg Assembly	7
Main Boom Assembly	8
Base Dipper Boom Assembly	9
Slide Dipper Boom Assembly	10
Bucket & Linkage Assembly.....	11
Seat Assembly	12
Swing Cylinder Assembly	13
Main Tower Cylinder Assembly.....	13
Stabilizer Cylinder Assembly	13
Dipper Boom Cylinder Assembly.....	13
Bucket Cylinder Assembly	14
Slide Cylinder Assembly	14
Hydraulics & Valve Assemblies.....	15
Foot Valve Assembly	15
Hydraulic Hose Schematics	16
Hydraulic Hose List	17
Label Layout.....	18
Label Layout - Grease Points	19
Accessories.....	20

Maintenance should be performed by
trained personnel only.



Refer to the operators
manual for safe
operation and
maintenance

Bolt Torque

CHECKING BOLT TORQUE

The tables shown below give correct torque values for various bolts and capscrews. Tighten all bolts to the torques specified in chart unless otherwise noted. Check tightness of bolts periodically, using bolt torque chart as a guide. Replace hardware with the same strength bolt.

ENGLISH TORQUE SPECIFICATIONS						
Bolt Diameter "A"	Bolt Torque*					
	SAE 2 (N.m) (lb-ft)		SAE 5 (N.m) (lb-ft)		SAE 8 (N.m) (lb-ft)	
1/4"	8	6	12	9	17	12
5/16"	13	10	25	19	36	27
3/8"	27	20	45	33	63	45
7/16"	41	30	72	53	100	75
1/2"	61	45	110	80	155	115
9/16"	95	60	155	115	220	165
5/8"	128	95	215	160	305	220
3/4"	225	165	390	290	540	400
7/8"	230	170	570	420	880	650
1"	345	225	850	630	1320	970

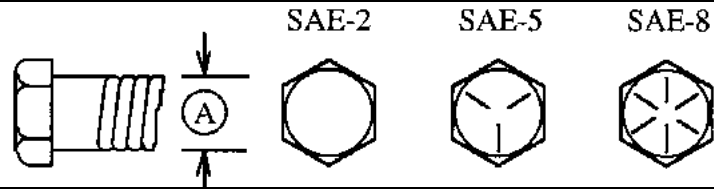

Torque figures indicated above are valid for non-greased or non-oiled threads and heads unless otherwise specified. Therefore, do not grease or oil bolts or capscrews unless otherwise specified in this manual. When using locking elements, increase torque values by 5%.

* Torque value for bolts and capscrews are identified by their head markings.

METRIC TORQUE SPECIFICATIONS				
Bolt Diameter "A"	Bolt Torque*			
	8.8 (N.m) (lb-ft)		10.9 (N.m) (lb-ft)	
M3	0.5	0.4	1.8	1.3
M4	3	2.2	4.5	3.3
M5	6	4	9	7
M6	10	7	15	11
M8	25	18	35	26
M10	50	37	70	52
M12	90	66	125	92
M14	140	103	200	148
M16	225	166	310	229
M20	435	321	610	450
M24	750	553	1050	774
M30	1495	1103	2100	1550
M36	2600	1917	3675	2710

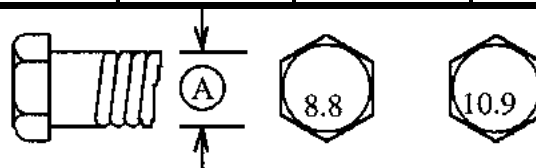

Hydraulic Fitting Torque

Tightening Flare Type Tube Fittings *

1. Check flare and flare seat for defects that might cause leakage.
 2. Align tube with fitting before tightening.
 3. Lubricate connection and hand tighten swivel nut until snug.
 4. To prevent twisting the tube(s), use two wrenches. Place one wrench on the connector body and with the second tighten the swivel nut to the torque shown.
- The torque values shown are based on lubricated connections as in reassembly.

HYDRAULIC FITTING TORQUE					
Tube Size OD	Nut Size Across Flats	Torque Value*		Recommended Turns To Tighten (After Finger Tightening)	
		(N.m)	(lb-ft)	(Flats)	(Turn)
(in.)	(in.)				
3/16	7/16	8	6	1	1/6
1/4	9/16	12	9	1	1/6
5/16	5/8	16	12	1	1/6
3/8	11/16	24	18	1	1/6
1/2	7/8	46	34	1	1/6
5/8	1	62	46	1	1/6
3/4	1-1/4	102	75	3/4	1/8
7/8	1-3/8	122	90	3/4	1/8

Main Frame Assembly

BOM ID	Part No.	Description	Qty
1	3012W250	Base, Main Frame	1
2	Z11121	Toplink Pin, 3/4" x 2-3/4"	1
3	Z12140	Lynch Pin, 7/16"	1
4	Z27221	Connex Bushing 1 ID x 1-1/4 OD x 1-1/2 long x 1/8 wall	4
5	Z27241	Connex Bushing 1-1/2 x 1-3/4	2
6	Z71517	Hex Bolt, 1/2NC x 1-3/4"	4
7	Z72251	Hex Lock Nut, 1/2NC	4
8	Z72221	Hex Lock Nut, 5/16NC	5
9	Z76113	Flange Bolt, 1/4NC x 3/8"	7
10	Z94152	GX Backhoe Operation Decal	1
11	3012C203	Cylinder, 2-1/2 x 7-3/4 Stroke	2
12	3012W252	Bar, Swing Cylinder Retaining	1
13	3011L204	Shield, Control Valve	1
14	Z29202	Grease Zerk 1/4NF	2
15	Z29203	Grease Zerk 90, 1/4NF	2
16	Z71225	Hex Bolt, 5/16NC x 2-1/2"	2

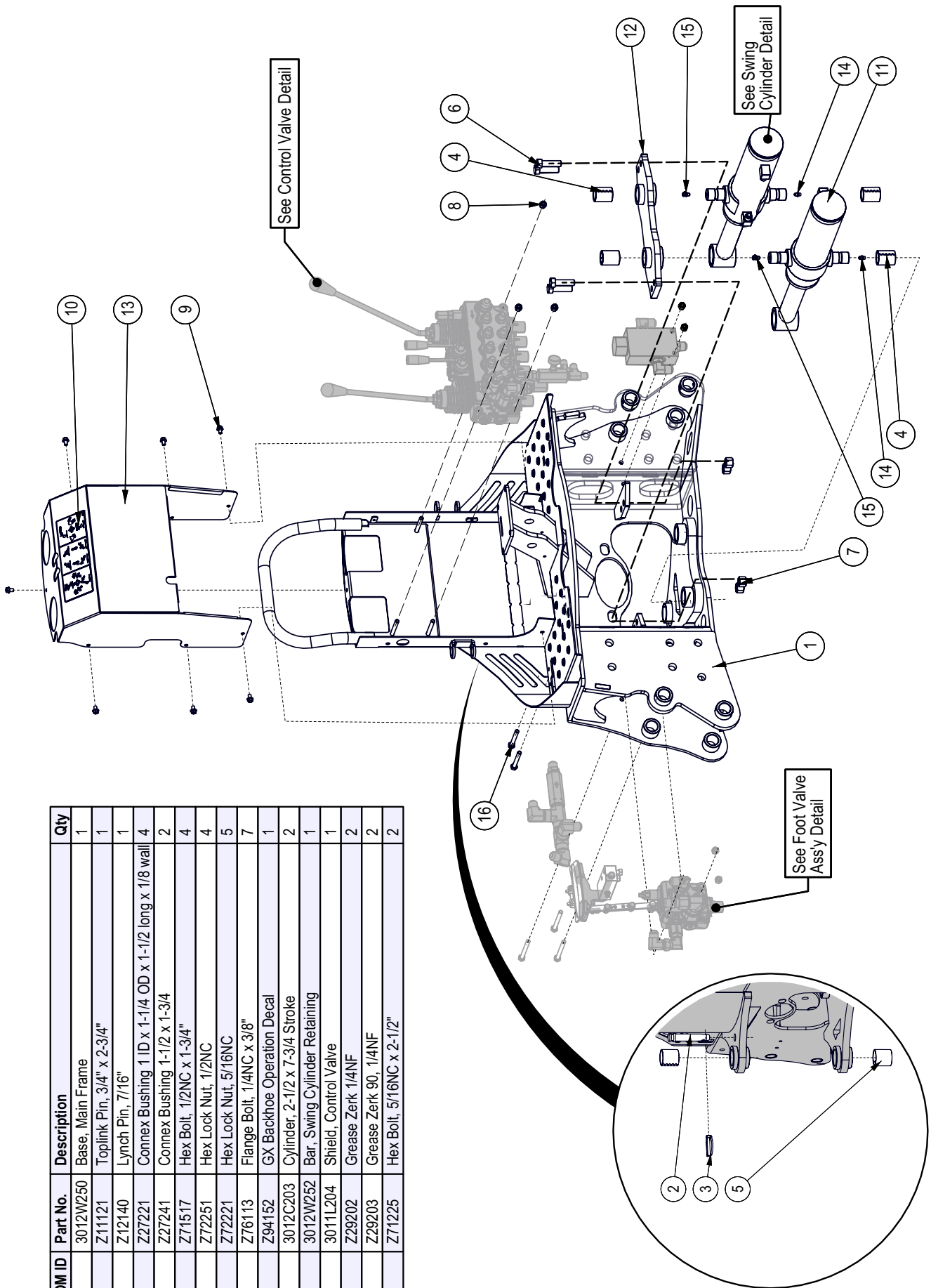

Stabilizer Leg Assembly

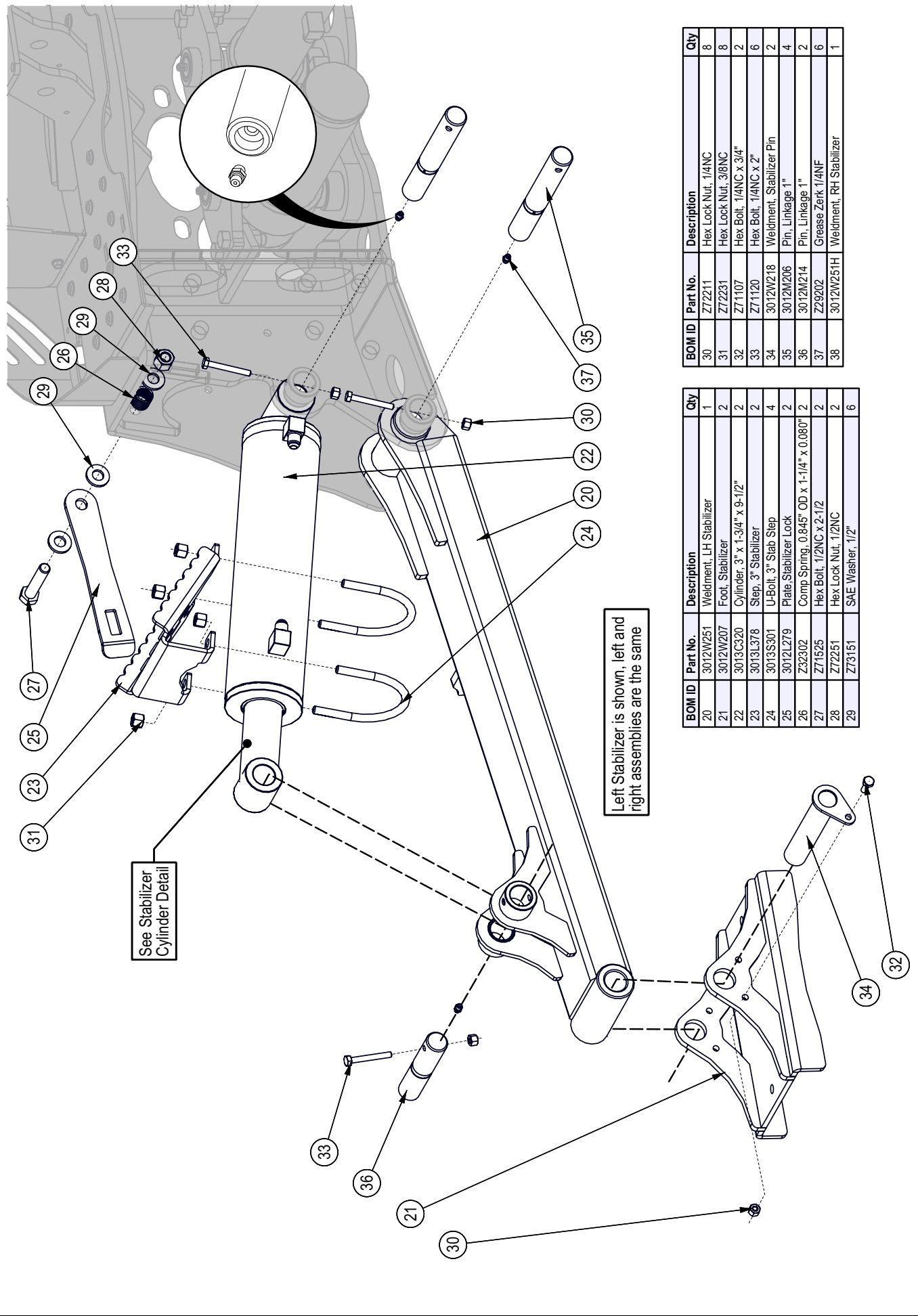

See Stabilizer
Cylinder Detail

Left Stabilizer is shown, left and
right assemblies are the same

BOM ID	Part No.	Description	Qty
20	3012W251	Weldment, LH Stabilizer	1
21	3012W207	Foot, Stabilizer	2
22	3013C320	Cylinder, 3" x 1-3/4" x 9-1/2"	2
23	3013L378	Step, 3" Stabilizer	2
24	3013S301	U-Bolt, 3" Stab Step	4
25	3012L279	Plate, Stabilizer, Lock	2
26	Z32302	Comp Spring, 0.845" OD x 1-1/4" x 0.080"	2
27	Z71525	Hex Bolt, 1/2NC x 2-1/2	2
28	Z72251	Hex Lock Nut, 1/2NC	2
29	Z73151	SAE Washer, 1/2"	6

BOM ID	Part No.	Description	Qty
30	Z72211	Hex Lock Nut, 1/4NC	8
31	Z72231	Hex Lock Nut, 3/8NC	8
32	Z71107	Hex Bolt, 1/4NC x 3/4"	2
33	Z71120	Hex Bolt, 1/4NC x 2"	6
34	3012W218	Weldment, Stabilizer Pin	2
35	3012M206	Pin, Linkage 1"	4
36	3012M214	Pin, Linkage 1"	2
37	Z29202	Grease Zerk, 1/4NF	6
38	3012W251H	Weldment, RH Stabilizer	1

Main Boom Assembly

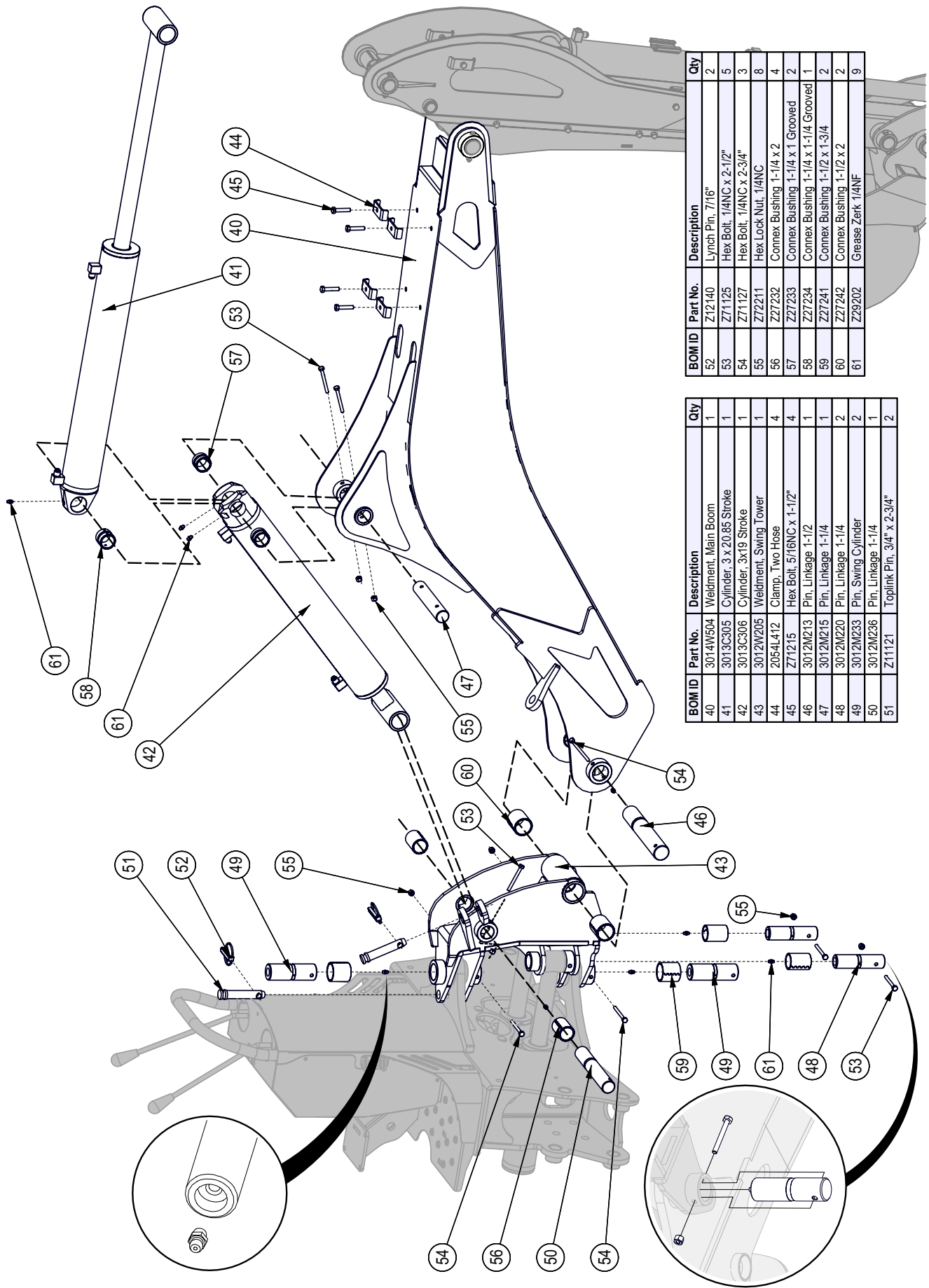

BOM ID	Part No.	Description	Qty
52	Z12140	Lynch Pin, 7/16"	2
53	Z71125	Hex Bolt, 1/4NC x 2-1/2"	5
54	Z71127	Hex Bolt, 1/4NC x 2-3/4"	3
55	Z72211	Hex Lock Nut, 1/4NC	8
56	Z27232	Connex Bushing 1-1/4 x 2	4
57	Z27233	Connex Bushing 1-1/4 x 1 Grooved	2
58	Z27234	Connex Bushing 1-1/4 x 1-1/4 Grooved	1
59	Z27241	Connex Bushing 1-1/2 x 1-3/4	2
60	Z27242	Connex Bushing 1-1/2 x 2	2
61	Z29202	Grease Zerk 1/4NF	9

BOM ID	Part No.	Description	Qty
40	3014W504	Weldment, Main Boom	1
41	3013C305	Cylinder, 3 x 20.85 Stroke	1
42	3013C306	Cylinder, 3x19 Stroke	1
43	3012W205	Weldment, Swing Tower	1
44	2054L412	Clamp, Two Hose	4
45	Z71215	Hex Bolt, 5/16NC x 1-1/2"	4
46	3012M213	Pin, Linkage 1-1/2	1
47	3012M215	Pin, Linkage 1-1/4	1
48	3012M220	Pin, Linkage 1-1/4	2
49	3012M233	Pin, Swing Cylinder	2
50	3012M236	Pin, Linkage 1-1/4	1
51	Z71121	Toplink Pin, 3/4" x 2-3/4"	2

Base Dipper Boom Assembly

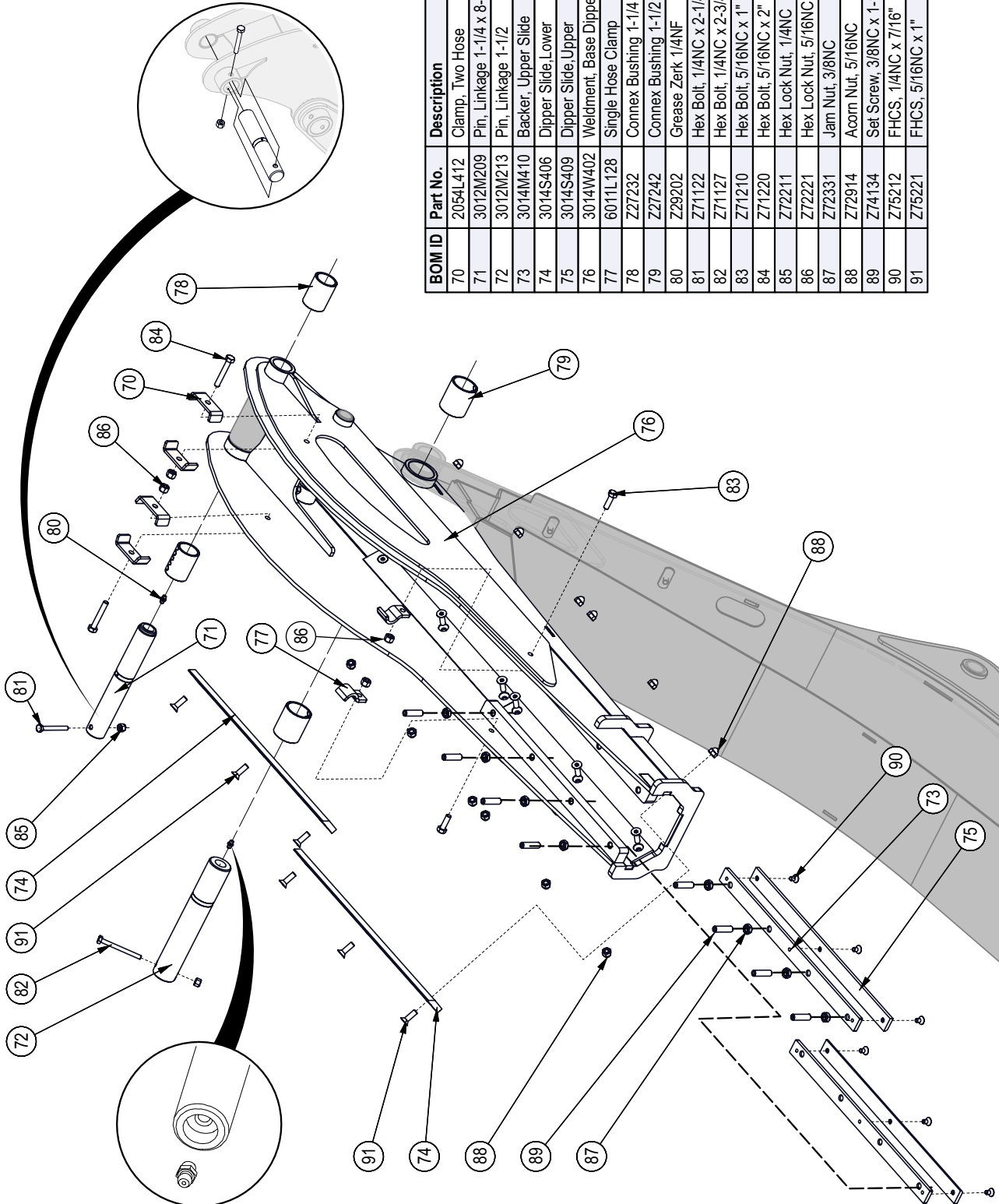

BOM ID	Part No.	Description	Qty
70	2054L412	Clamp, Two Hose	4
71	3012M209	Pin, Linkage 1-1/4 x 8-3/8	1
72	3012M213	Pin, Linkage 1-1/2	1
73	3014M410	Backer, Upper Slide	2
74	3014S406	Dipper Slide, Lower	4
75	3014S409	Dipper Slide, Upper	2
76	3014W402	Weldment, Base Dipper Boom XT	1
77	6011L128	Single Hose Clamp	2
78	Z27232	Connex Bushing 1-1/4 x 2	2
79	Z27242	Connex Bushing 1-1/2 x 2	2
80	Z29202	Grease Zerk 1/4NF	2
81	Z71122	Hex Bolt, 1/4NC x 2-1/4"	1
82	Z71127	Hex Bolt, 1/4NC x 2-3/4"	1
83	Z71210	Hex Bolt, 5/16NC x 1"	2
84	Z71220	Hex Bolt, 5/16NC x 2"	2
85	Z72211	Hex Lock Nut, 1/4NC	2
86	Z72221	Hex Lock Nut, 5/16NC	4
87	Z72331	Jam Nut, 3/8NC	8
88	Z72914	Acorn Nut, 5/16NC	12
89	Z74134	Set Screw, 3/8NC x 1-1/2"	8
90	Z75212	FHCS, 1/4NC x 7/16"	6
91	Z75221	FHCS, 5/16NC x 1"	12

Slide Dipper Boom Assembly

To Foot Valve Port B

To Foot Valve Port A

BOM ID	Part No.	Description	Qty
109	Z46103	Internal Retaining Ring, 1-1/4"	2
110	Z51641	Straight, MJC x MORB 0606	2
111	Z71120	Hex Bolt, 1/4NC x 2"	1
112	Z72211	Hex Lock Nut, 1/4NC	3
113	Z78301	Machine Screw, 1/4NC x 3/4"	2
114	Z96601	Sign, Slow Moving Vehicle	1
115	Z96602	Spade, Slow Moving Vehicle	1
116	Z96603	Socket, Slow Moving Vehicle	1

BOM ID	Part No.	Description	Qty
100	3014M403	Weldment, Slide Dipper Boom XT	1
101	3014C402	Cylinder, 1-3/4" x 23-1/4" Stroke	1
102	3014C407	Cylinder, 2-1/2" x 16-1/2" Stroke	1
103	3014M403	Pin, XT Cylinder Rod	1
104	3014M407	Pin, Linkage 1-1/4"	1
105	3014M409	Pin, XT Cylinder Butt	1
106	Z27235	Connex Bushing 1-1/4 x 1-1/2	2
107	Z29202	Grease Zerk 1/4NF	1
108	Z46102	Retaining Ring, Internal 1"	2

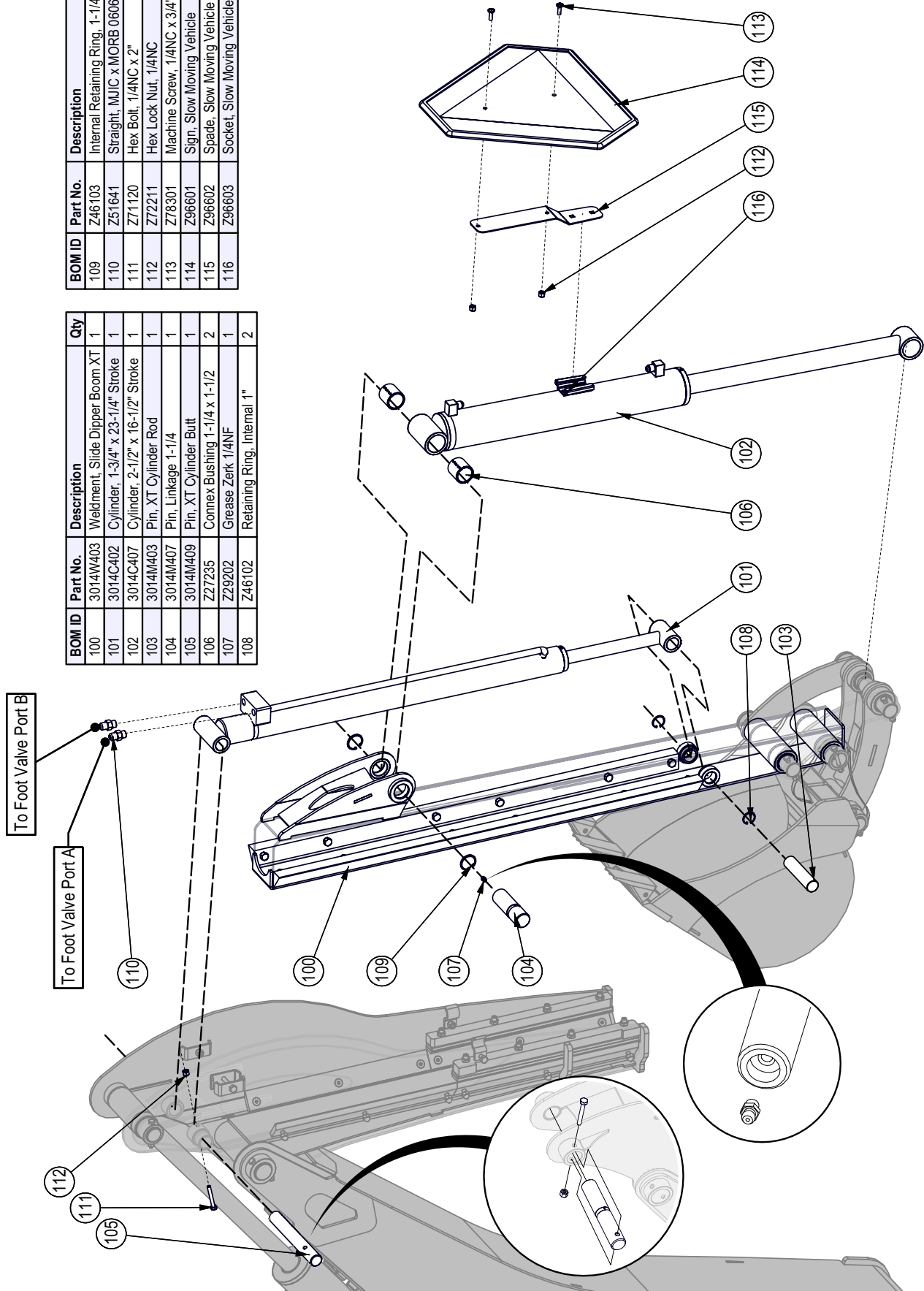

Bucket & Linkage Assembly

BOM ID	Part No.	Description	Qty
110	3012M209	Pin, Linkage 1-1/4 x 8-3/8	2
111	3012W202	Weldment, RH Bucket Linkage	1
112	3012W203	Weldment, Middle Bucket Linkage	1
113	3012W217	Bucket Pin w/ Washer	2
114	3012W220	Weldment, LH Bucket Linkage	1
115	3082W051	Weldment, GX720 12" Backhoe Bucket	1
116	Z14181	Roll Pin, 5/16" x 1-1/2"	3
117	Z19902	Tooth, Backhoe Pin-on	3
118	Z29202	Grease Zerk 1/4NF	4
119	Z71122	Hex Bolt, 1/4NC x 2-1/4"	4
120	Z72211	Hex Lock Nut, 1/4NC	4
121	Z27232	Connex Bushing 1-1/4 x 2	6
122	Z27231	Connex Bushing 1-1/4 x 1-3/4	3

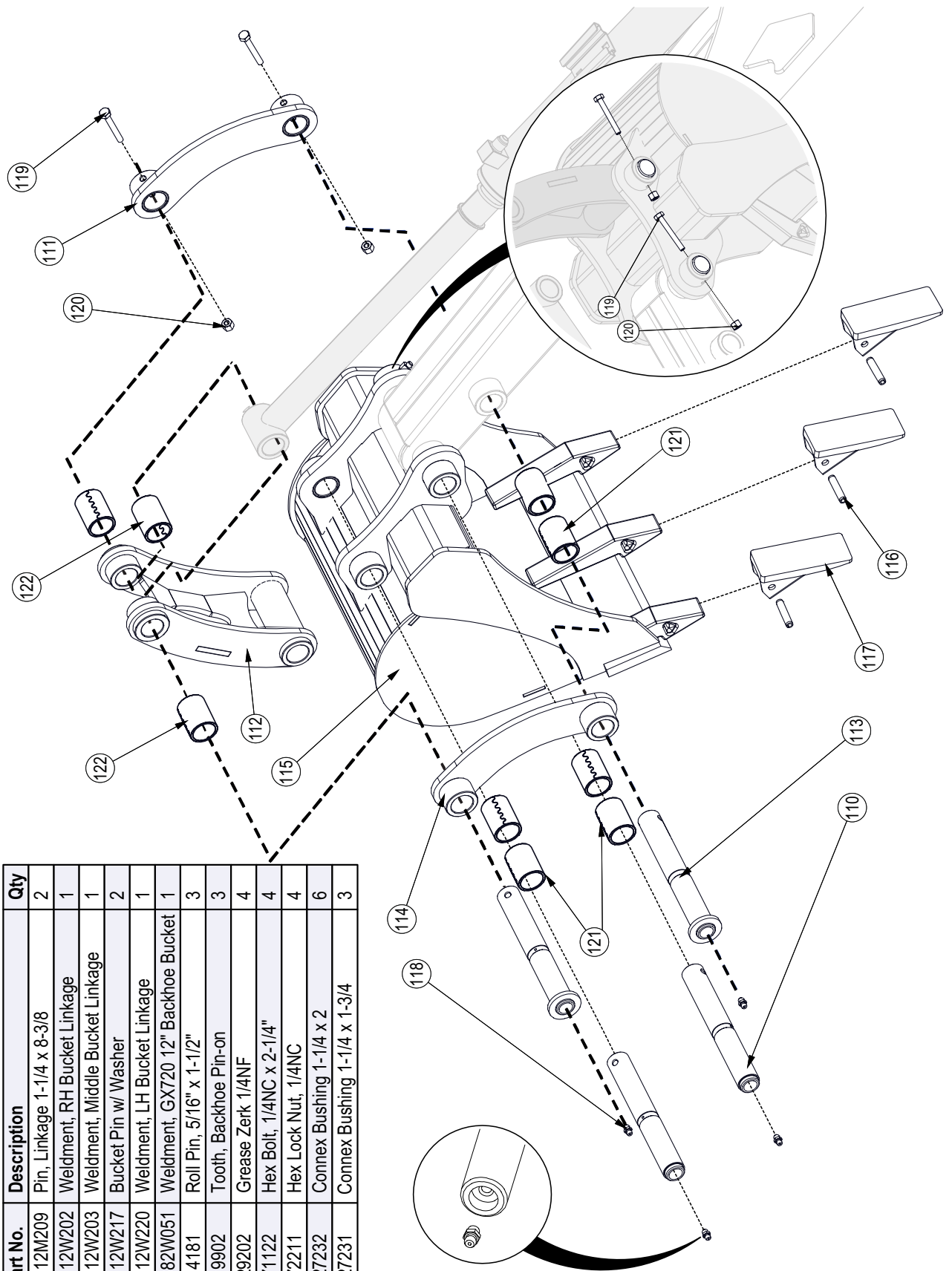

Seat Assembly

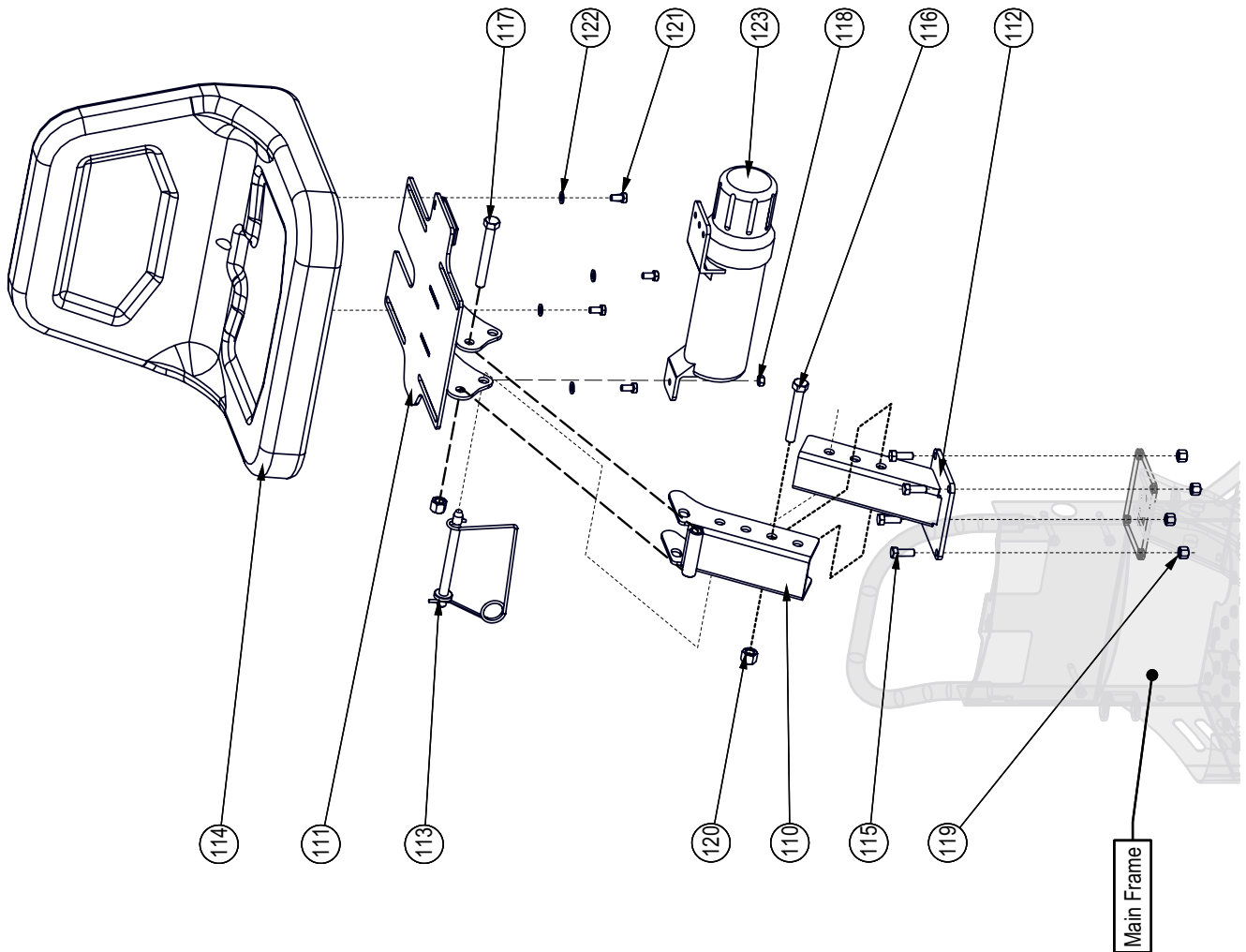

BOM ID	Part No.	Description	Qty
110	3011W112	Mount, Seat	1
111	3011W113	Plate, Seat	1
112	3011W111	Base, Seat	1
113	Z12441	Snap Lock Pin, 1/2" x 4-1/2"	1
114	Z19201	High-Back Backhoe Seat	1
115	Z71310	Hex Bolt, 3/8NC x 1"	4
116	Z71535	Hex Bolt, 1/2NC x 3-1/2"	1
117	Z71540	Hex Bolt, 1/2NC x 4"	1
118	Z72121	Hex Nut, 5/16NC	1
119	Z72231	Hex Lock Nut, 3/8NC	4
120	Z72251	Hex Lock Nut, 1/2NC	2
121	Z77152	Hex Bolt, M8x1.25 x 16mm	4
122	Z77352	DIN 125 Washer, M8	4
123	Z96503	Manual Tube, 3-1/2" Short	1

Swing Cylinder Assembly

Seal Kit #SLK-2515

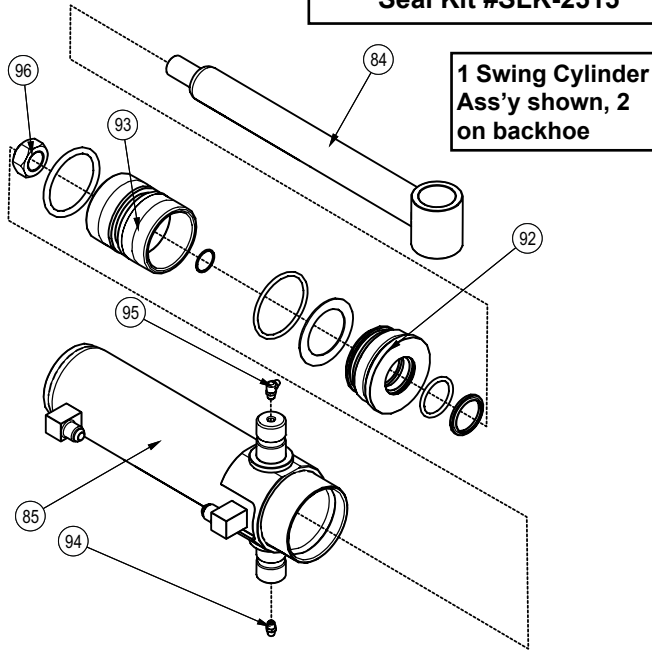

BOM ID	Part No.	Description	Qty
84	3012C2033	Rod, 1-1/2" x 1	1
85	3012C2034	Barrel, 2-1/2" Trunnion Mount	1
92	G250-150S	Gland, 2-1/2" x 1-1/2"	1
93	P100-250CP	Piston, 2-1/2" Bore x Cushion	1
94	Z29202	Grease Zerk 1/4NF	1
95	Z29203	Grease Zerk 90, 1/4NF	1
96	Z72276	Hex Thick Nut, 3/4NF	1

Stabilizer Cylinder Assembly

Seal Kit #SLK-3017

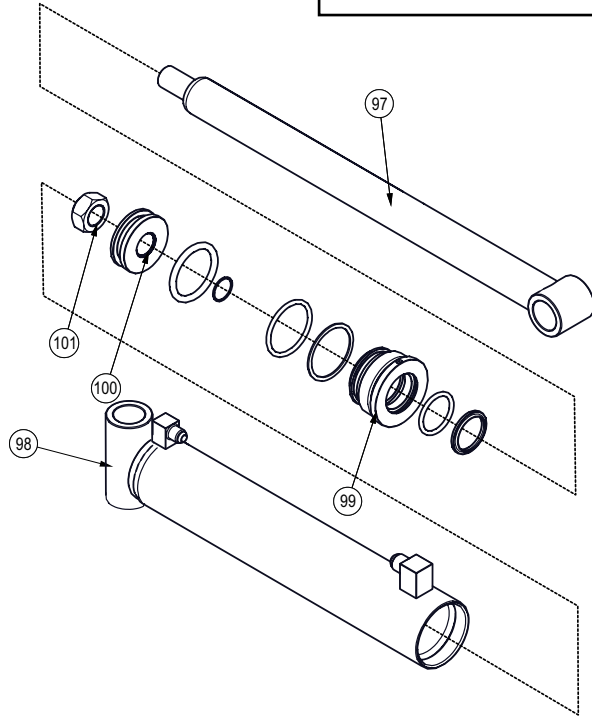

BOM ID	Part No.	Description	Qty
97	3013C3203	Rod, 1-3/4" x 1"	1
98	3013C3204	Barrel, 3"	1
99	G300-175S	Gland, 3" x 1-3/4"	1
100	P100-300SP	Piston, 3" Bore	1
101	Z72292G8	Hex Lock Nut, 1-1/4NF G8	1

Main Tower Cylinder Assembly

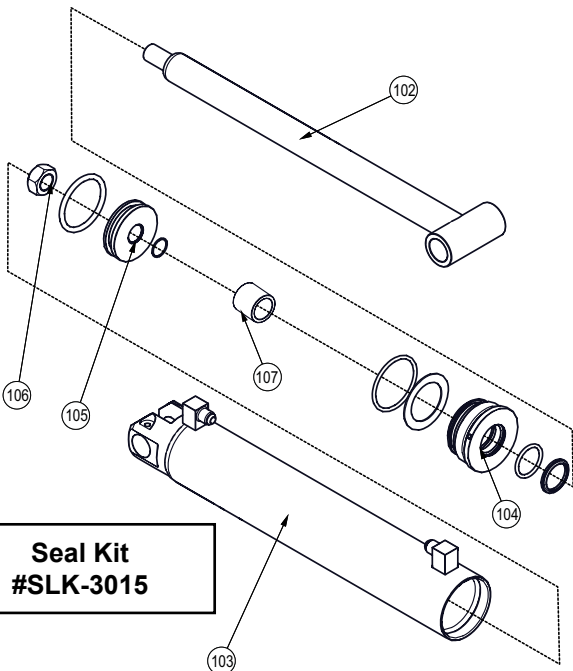

BOM ID	Part No.	Description	Qty
102	3013C3063	Rod, 1-1/2" x 1NF	1
103	3013C3064	Barrel, 3"	1
104	G300-150S	Gland, 3" x 1-1/2"	1
105	P100-300SP	Piston, 3" Bore	1
106	Z72276	Hex Top-lock Nut, 3/4NF	1
107	3013C3067	Internal Stroke Stop	1

Dipper Boom Cylinder Assembly

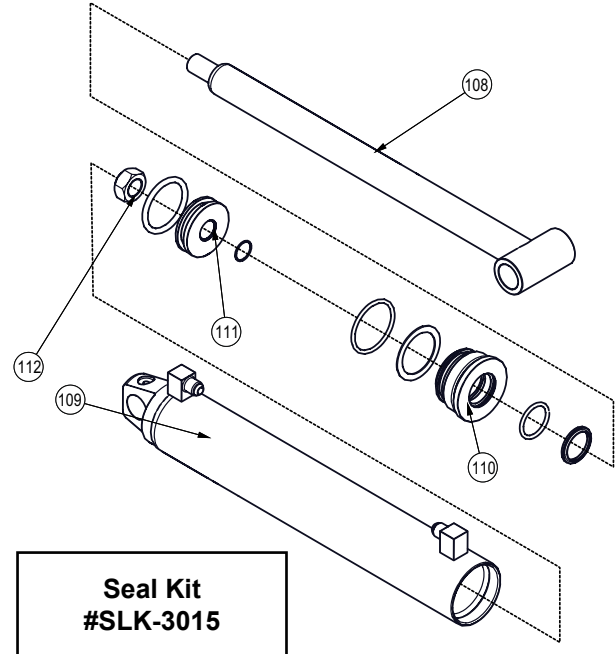

BOM ID	Part No.	Description	Qty
108	3013C3053	Rod, 1-1/2" x 1NF	1
109	3013C3054	Barrel, 3"	1
110	G300-150S	Gland, 3" x 1-1/2"	1
111	P100-300SP	Piston, 3" Bore	1
112	Z72276	Hex Top-lock Nut, 3/4NF	1

Bucket Cylinder Assembly

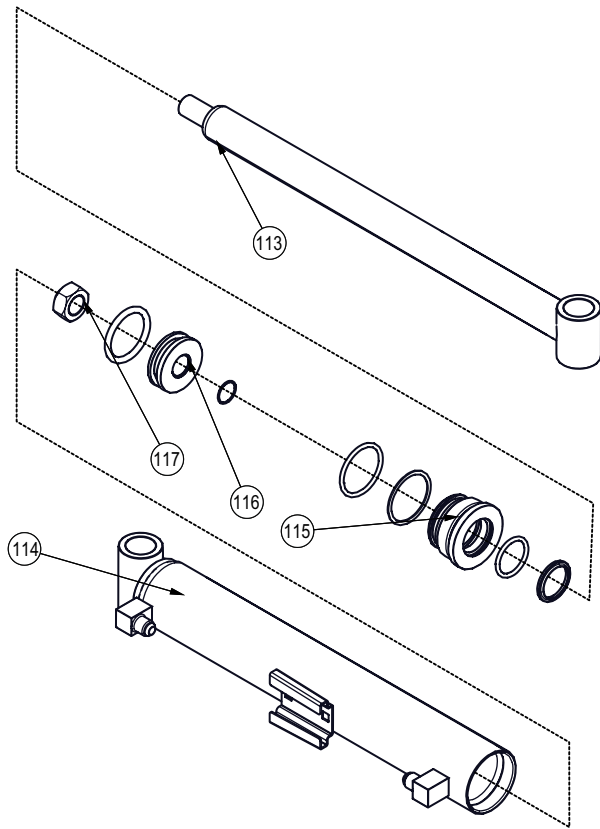

**Seal Kit
#SLK-2515**

BOM ID	Part No.	Description	Qty
113	3014C4073	Rod, 1-1/2" x 1NF	1
114	3014C4074	Barrel, 2-1/2"	1
115	G250-150S	Gland, 2-1/2" x 1-1/2"	1
116	P100-250SP	Piston, 2-1/2" Bore	1
117	Z72272	Hex Lock Nut, 3/4NF G8	1

Slide Cylinder Assembly

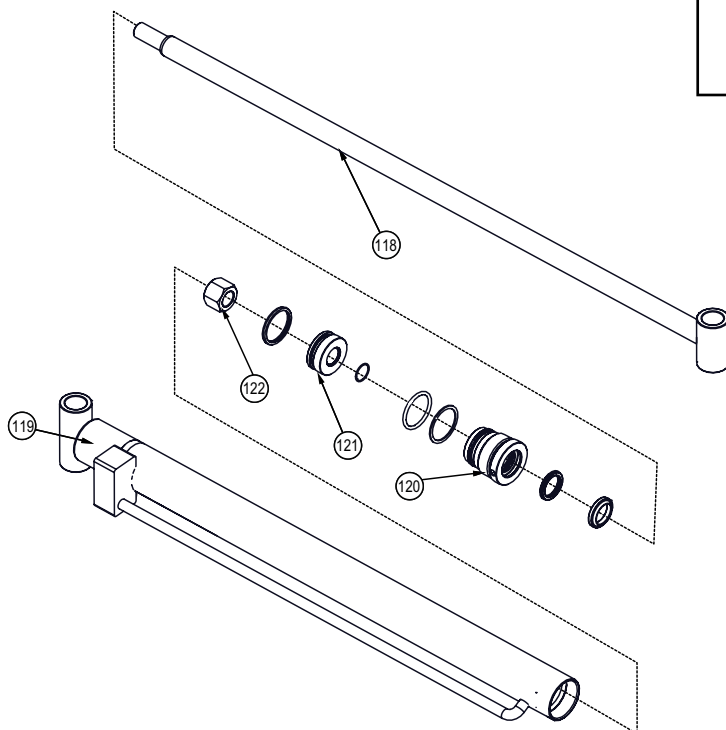

**Seal Kit
#SLK-1710**

BOM ID	Part No.	Description	Qty
118	3014C4023	Rod, 1-3/4" x 1NF	1
119	3014C4024	Barrel, 1-3/4" Bore	1
120	G175-100S	Gland, 1-3/4" x 1"	1
121	P150-175SP	Piston, 1-3/4" Bore	1
122	Z72272	Hex Lock Nut, 3/4NF G8	1

Hydraulics & Valve Assemblies

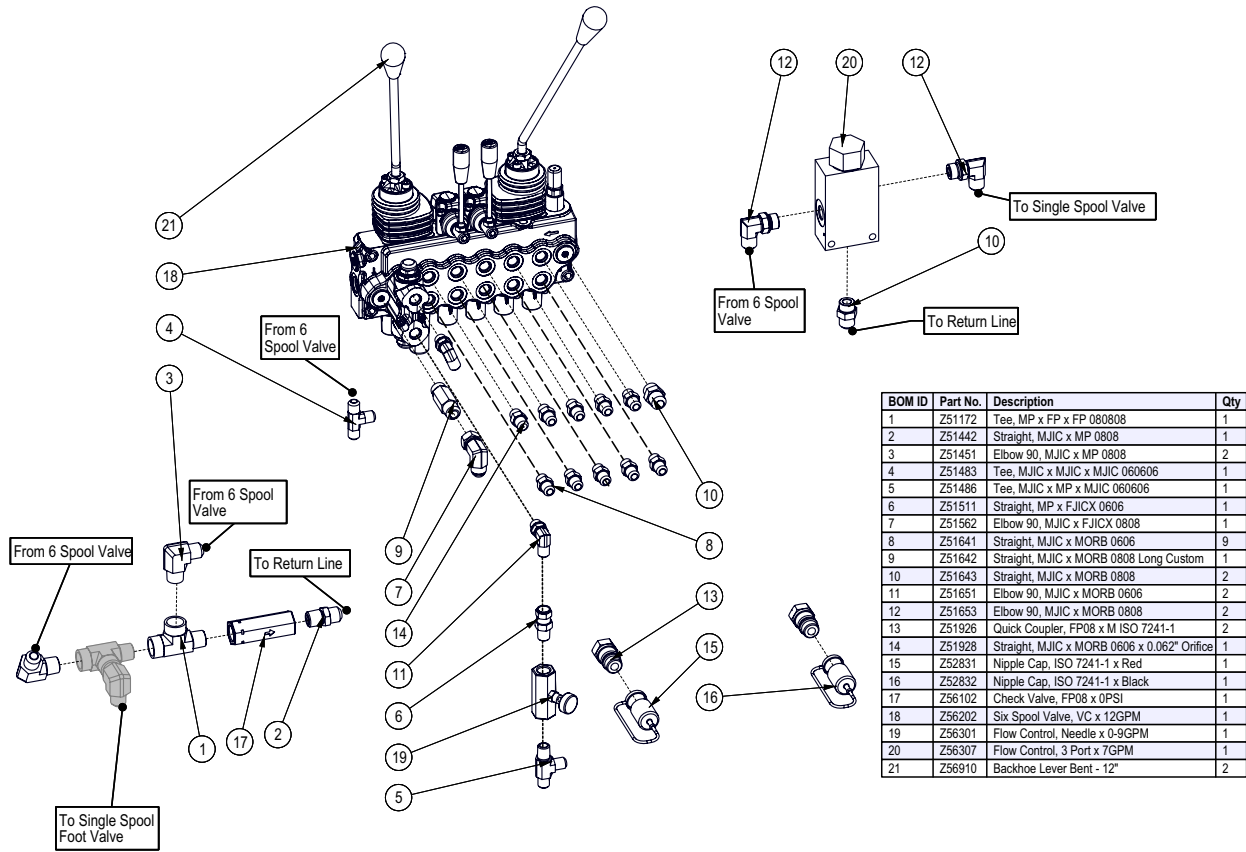

Foot Valve Assembly

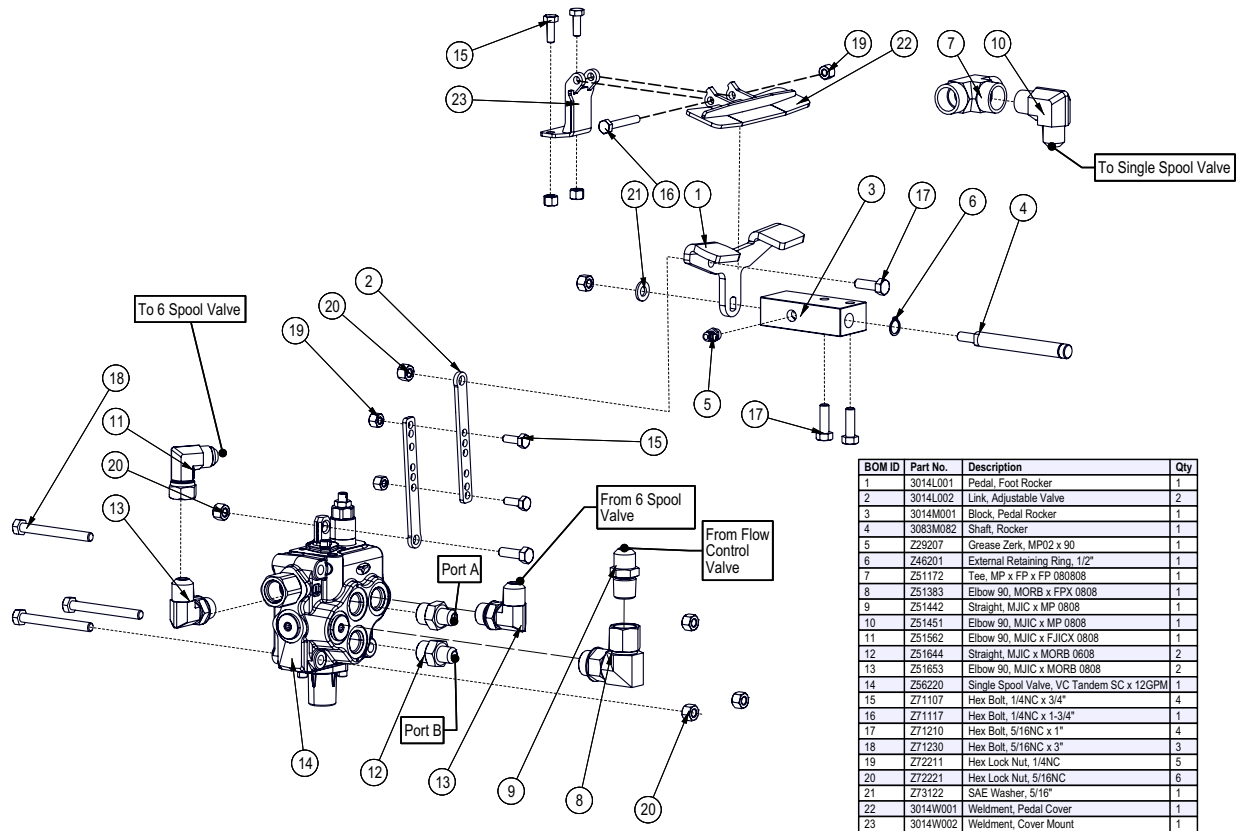

Valve Service Parts

Part No.	Description
3CU1210133	1[S]/SD5 SPOOL
3CU1245620	5PY/SD5 SPOOL
3XTAP822150	TCEI SAE8 PLUG
4GUA115926	15.88X2.62 NBR 70 SH O-RING SEAL
XTAP623170	AET/SD5 PLUG
5V08105000	SPRING CENTER KIT
5V13405020	FLOAT KIT
LCN5(1-4)	LCB6 JOYSTICK KIT FUNCTION 1-4
LCN5(2-3)	LCB6 JOYSTICK KIT FUNCTION 2-3
5LEVI105000	L5 LEVER BOX
602001101	PORT RELIEF BLOCK
5KIT105413	RELIEF VALVE

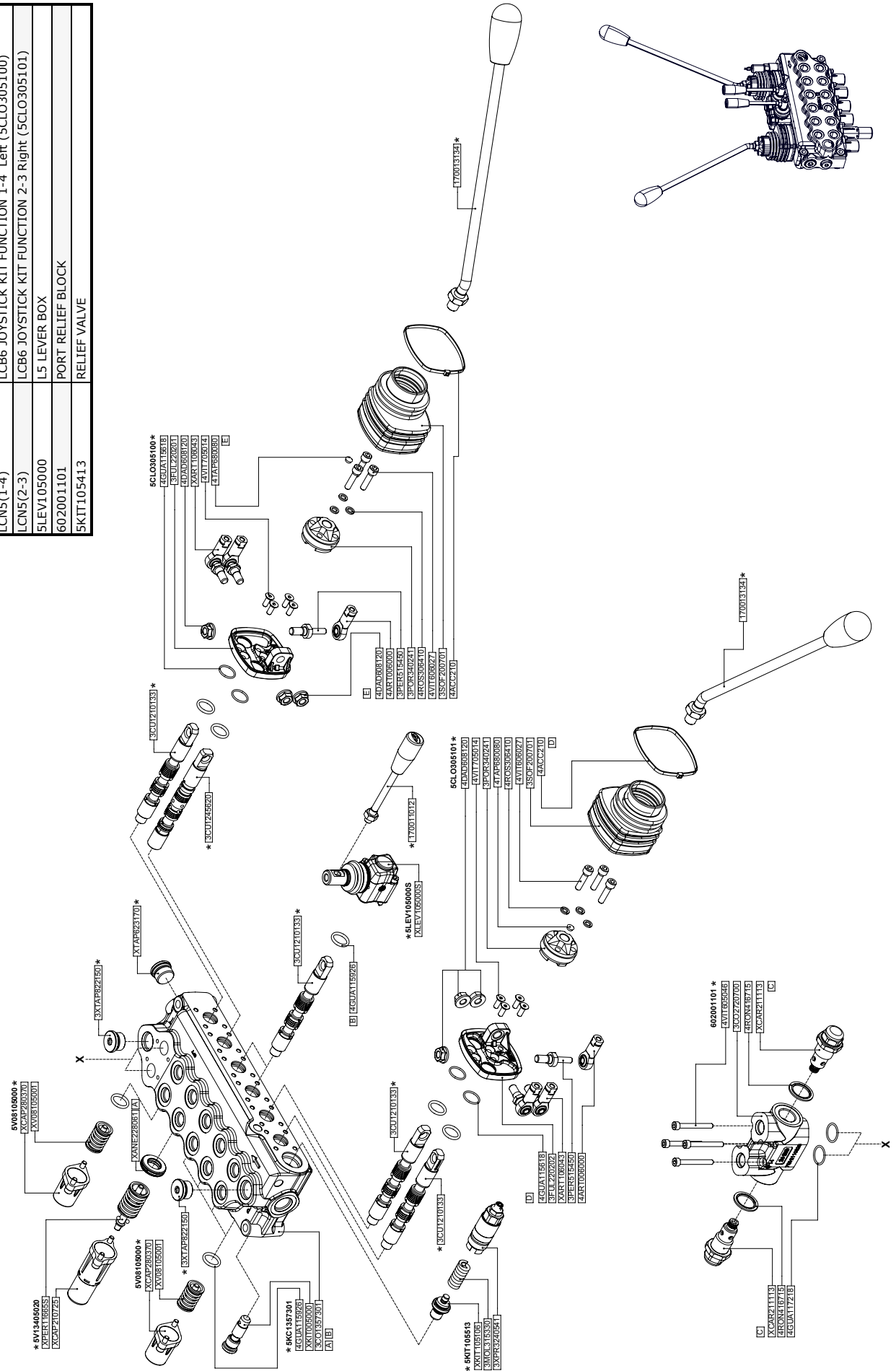

Hydraulic Hose Schematics

Open Center

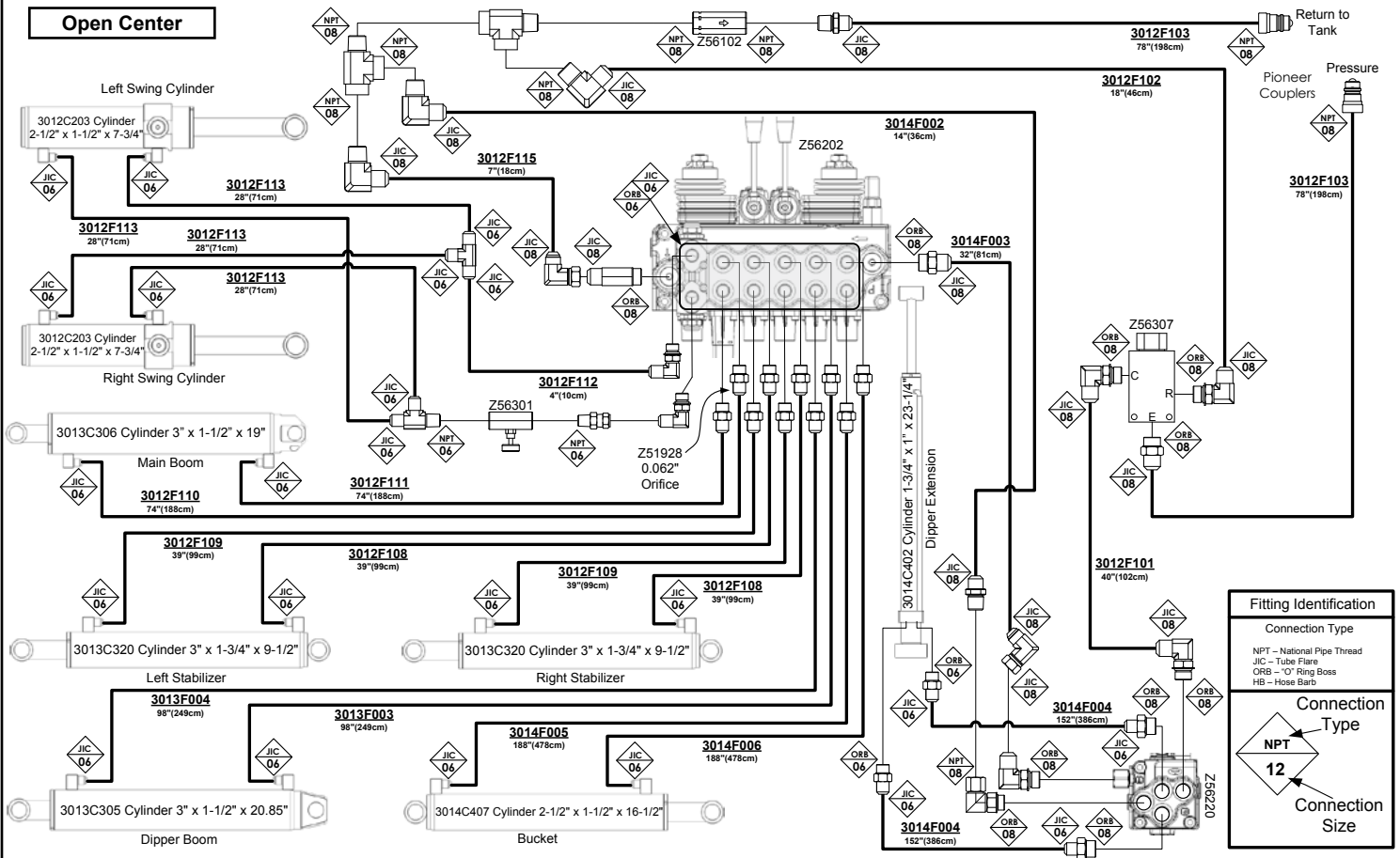

Fitting Identification	
Connection Type	
NPT	National Pipe Thread
JIC	Tube Flare
ORB	Ring Boss
HB	Hose Barb
Connection Type	
NPT	12
Connection Size	

Closed Center

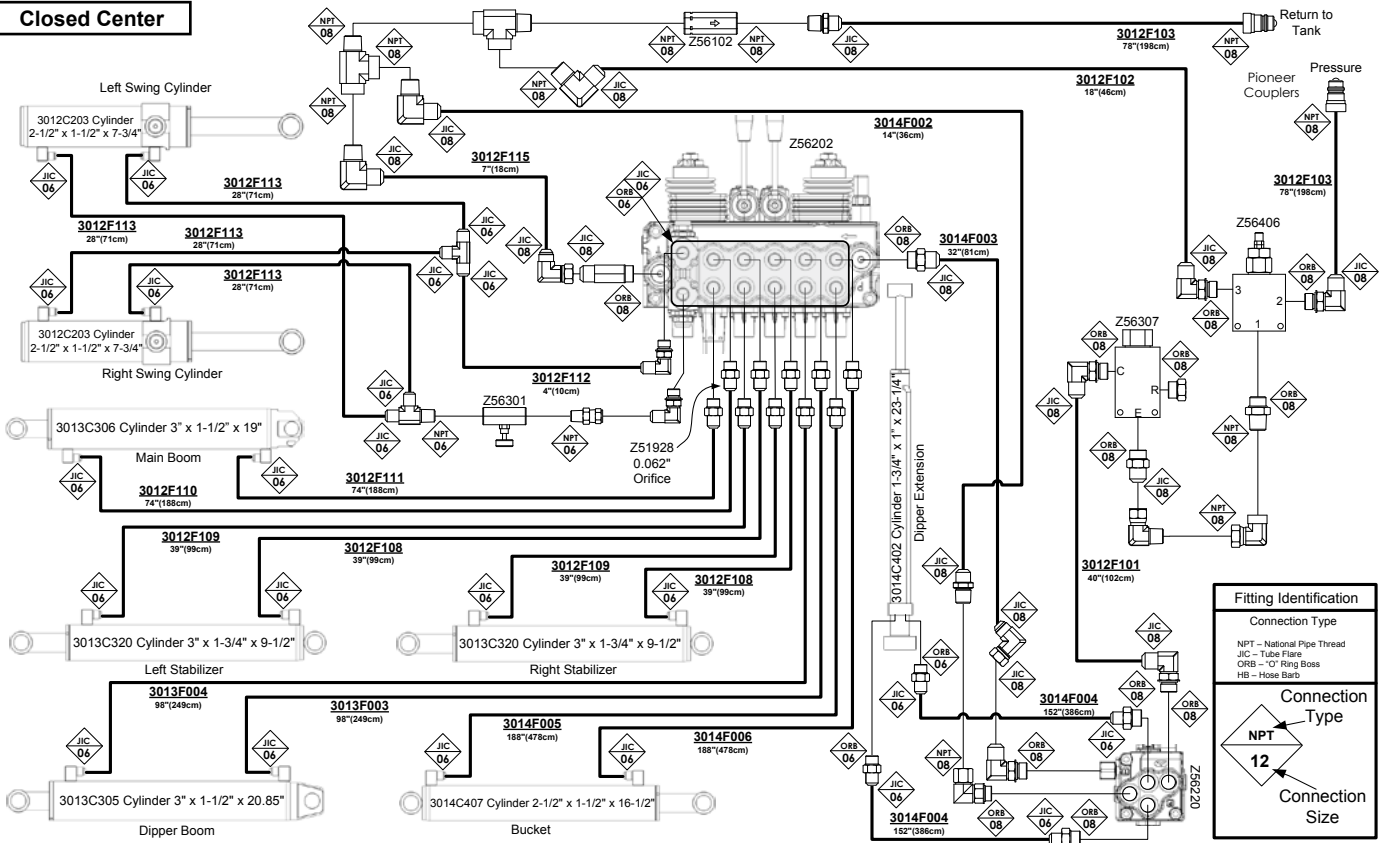

Fitting Identification	
Connection Type	
NPT	National Pipe Thread
JIC	Tube Flare
ORB	Ring Boss
HB	Hose Barb
Connection Type	
NPT	12
Connection Size	

Hydraulic Hose List

Part No.	Description	Qty
3012F101	1/2" Hose, FJIC08 x FJIC08 x 34	1
3012F102	1/2" Hose, FJIC08 x FJIC08 x 18	1
3012F103	1/2" Hose, Long 90 FJIC08 x MP08 x 78	2
3012F108	3/8" Hose, FJIC06 x Long 90 FJIC06 x 39	2
3012F109	3/8" Hose, FJIC06 x 90 FJIC06 x 39	2
3012F110	3/8" Hose, FJIC06 x Long 90 FJIC06 x 74	1
3012F111	3/8" Hose, FJIC06 x 90 FJIC06 x 74	1
3012F112	3/8" Hose, FJIC06 x FJIC06 x 4	1
3012F113	1/4" Hose, FJIC06 x FJIC06 x 28	4
3012F115	1/2" Hose, FJIC08 x FJIC08 x 7	1
3013F003	3/8" Hose, FJIC06 x Long 90 FJIC06 x 98	1
3013F004	3/8" Hose, FJIC06 x 90 FJIC06 x 98	1
3014F002	1/2" Hose, FJIC08 x 90 FJIC08 x 14	1
3014F003	1/2" Hose, FJIC08 x 90 FJIC08 x 32	1
3014F004	1/4" Hose, 90 FJIC06 x 90 FJIC06 x 152	2
3014F005	1/4" Hose, FJIC06 x 90 FJIC06 x 188	1
3014F006	1/4" Hose, FJIC06 x Long 90 FJIC06 x 188	1

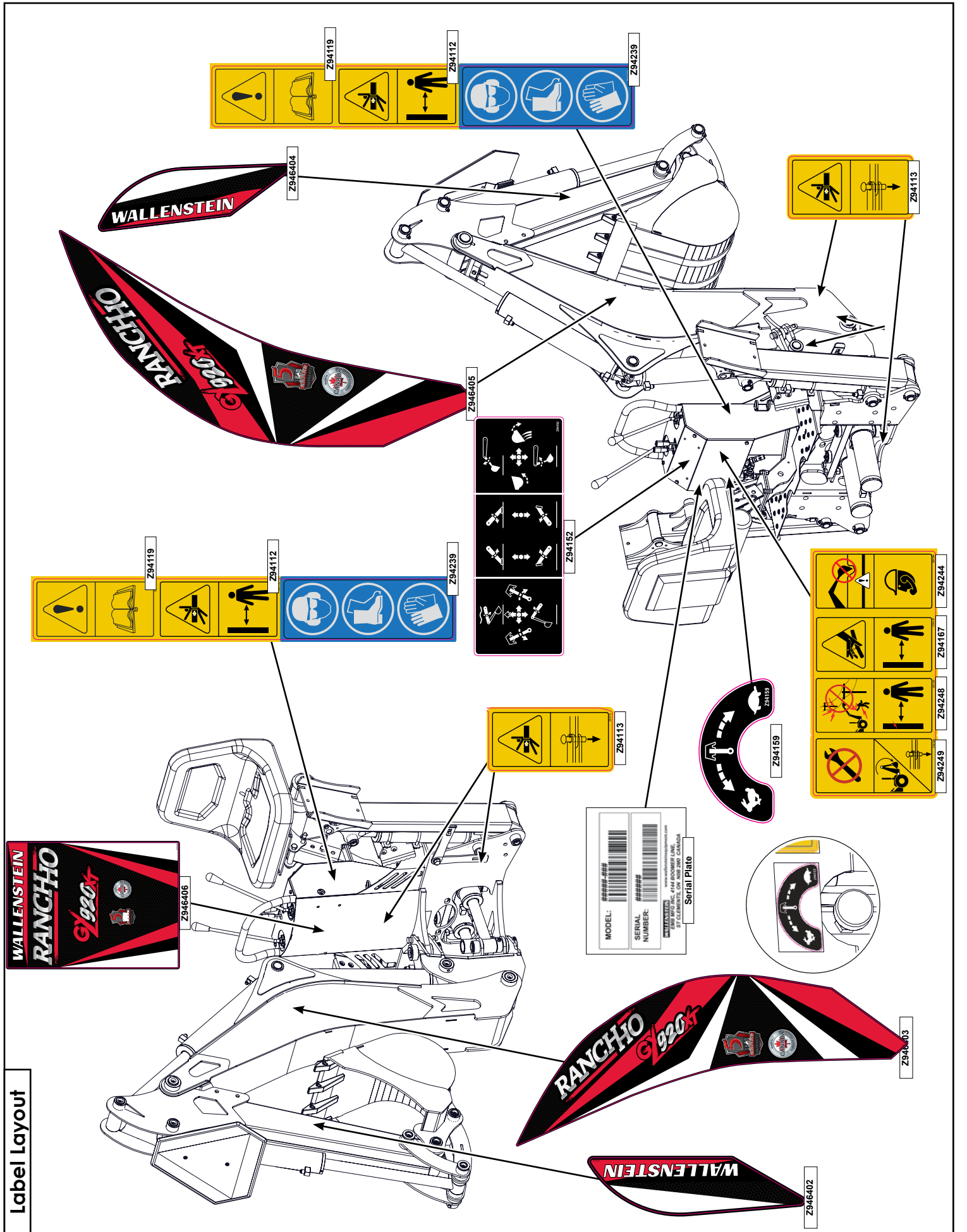

Label Layout

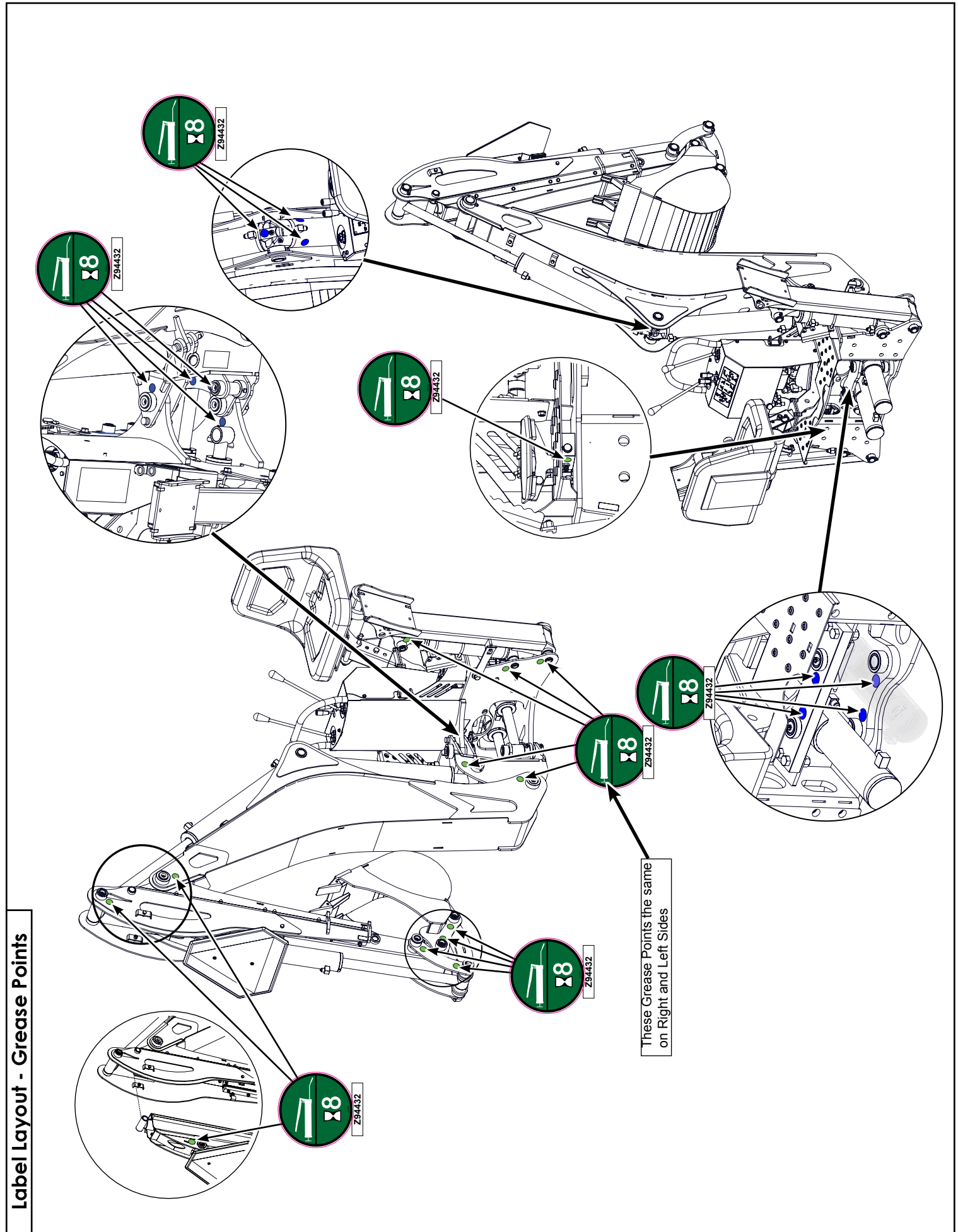

Label Layout - Grease Points

Accessories

PT300 3 Point Hitch

- Category I

BK2900 9" Bucket

- 3 teeth
- Bucket Volume: 0.8416 cubic ft

BK2120 12" Bucket

- 3 teeth
- Bucket Volume: 1.1694 cubic ft

BK2150 15" Bucket

- 4 teeth
- Bucket Volume: 1.4806 cubic ft

BK2180 18" Bucket

- 4 teeth
- Bucket Volume: 1.7912 cubic ft

BK2240 24" Bucket

- 5 teeth
- Bucket Volume: 2.413 cubic ft

BK2240D 24" Ditching Bucket

- No teeth
- Bucket Volume: 2.413 cubic ft

BT7220 Quick Change Bucket Adapter

Switches attachments quickly and easily with only one bolt and no hammering of pins.

BT7240 Vertical Stabilizer Kit

Allows digging closer to objects such as buildings and foundations while maintaining stability.

BT7270 Closed Center Kit

Provides for backhoe conversion from open center to closed center operation for tractors equipped with closed centre hydraulics.



EMB Manufacturing Inc.
4144 Boomer Line - St. Clements, On - N0B 2M0 - Canada
Ph: (519) 699-9283 - Fax: (519) 699-4146
www.embmfg.com

RANCHO SERIES BACKHOE

GE605, GX620, GX720, GX920 & GX920XT

OPERATOR'S MANUAL

Warning
Underground Utility Hazard
Contacting underground utilities can cause electrocution. You must contact an underground utility locating/marketing service before digging.

Caution
Stability Hazard
The tractor must have a front bucket loader installed before installing the subframe and backhoe. The front loader is required to offset the weight of the backhoe, as well as provide the stability required to operate the backhoe safely.

NOTICE
Operation Hazard
Wallenstein backhoes are designed to operate at a specific flow rate. Operating the backhoe above the specified flow rate will cause damage to the seals and will void the warranty.
GE605 3.5-6 gpm (13.3-22.8 lpm)
GX Series 5-7 gpm (18.9-26.5 lpm)

NOTICE
When mounting a GE605 or GX620 backhoe to a skid steer that has a flow rate greater than 8 GPM (32 lpm), BFC501 Flow Divider Kit is required to prevent damage to the seals and voiding the warranty. Do not run the skid steer in high flow mode.

**Keep this manual with the
Machine at all times** 

PRINTED IN CANADA
Rev: 160517
PART NUMBER: Z97103

#Z97103 BACKHOE OPERATORS MANUAL

Available as a download at
www.wallensteinequipment.com