



# WX515 Trailer Log Splitter Parts Manual

S/N 240001 & 240085



# Foreword

EMB Mfg. has prepared this parts manual to assist customers in ordering quality OEM replacement parts.

Proper and regular service and replacing old, worn or broken parts with the correct OEM parts are essential to prolonging the life of your EMB product. Please refer to this manual before ordering any replacement parts.

All information contained in this parts manual is based on the latest product specification available at the time of printing this manual. If your product differs from the specifications contained within this manual contact EMB Mfg. for information.

EMB reserves the right to alter specifications on their products at any time.

Reproduction of this parts manual of any kind is prohibited without prior written permission from EMB Mfg.

# Table of Contents

Cylinder	4
Valve and Fittings	4
Main Parts	5
Valve	6
Hub	8
Engine & Pump	9
Light Kit (Optional)	10
Decal Breakdown	12

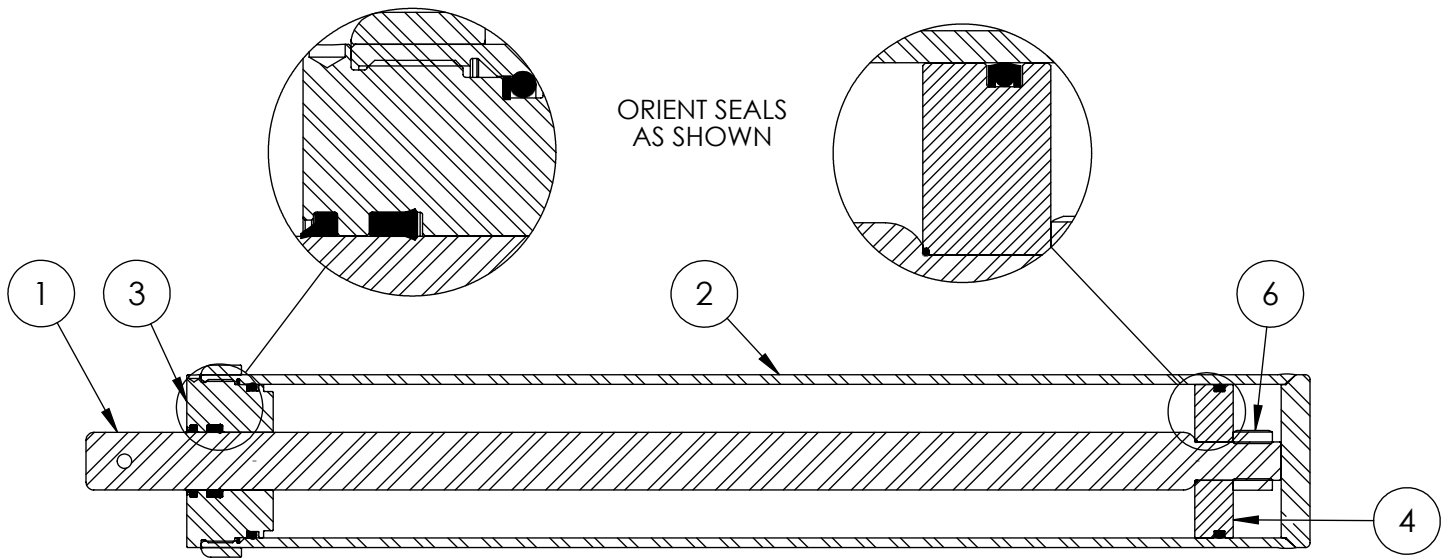

**4" x 24" STROKE CYLINDER PARTS**

ITEM	PART NO.	Description	QTY.
1	2011C1012	Rod, 1-1/2 x 1	1
2	2011C1014	Barrel, 4"	1
3	G400-150SA	4" Bore x 1-1/2" Rod Gland	1
4	P100-400SA	4" Bore Piston	1
5	SLK-4015	Seal Kit, 4 x 1-1/2	1
6	Z72292G8	Hex Lock Nut 1NF Grade 8	1

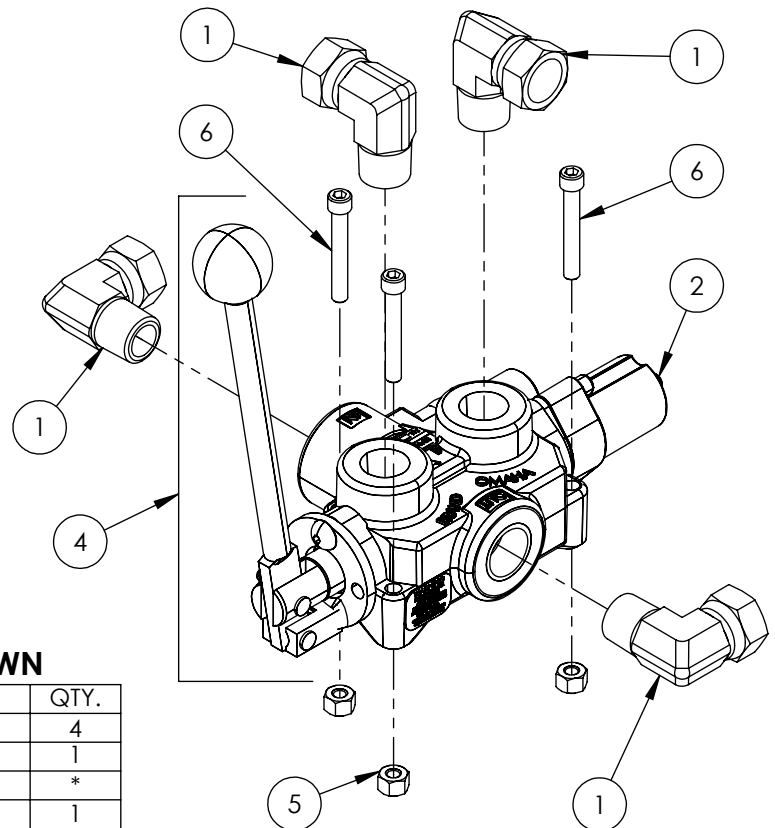

**VALVE AND FITTINGS PARTS BREAKDOWN**

ITEM	PART NO.	Description	QTY.
1	Z51331	Elbow 90 MP x FFX 0808	4
2	Z56209	Valve, Single Function Detent	1
3	*Z56210*	Valve, Closed Center	*
4	Z56915	Complete Handle Kit for Z56209	1
5	Z72111	Hex Lock Nut 1/4NC	3
6	Z75114	SHCS, 1/4NC x 1-3/4	3

\*CLOSED CENTER VALVE REQUIRED FOR "C" MODELS.\*

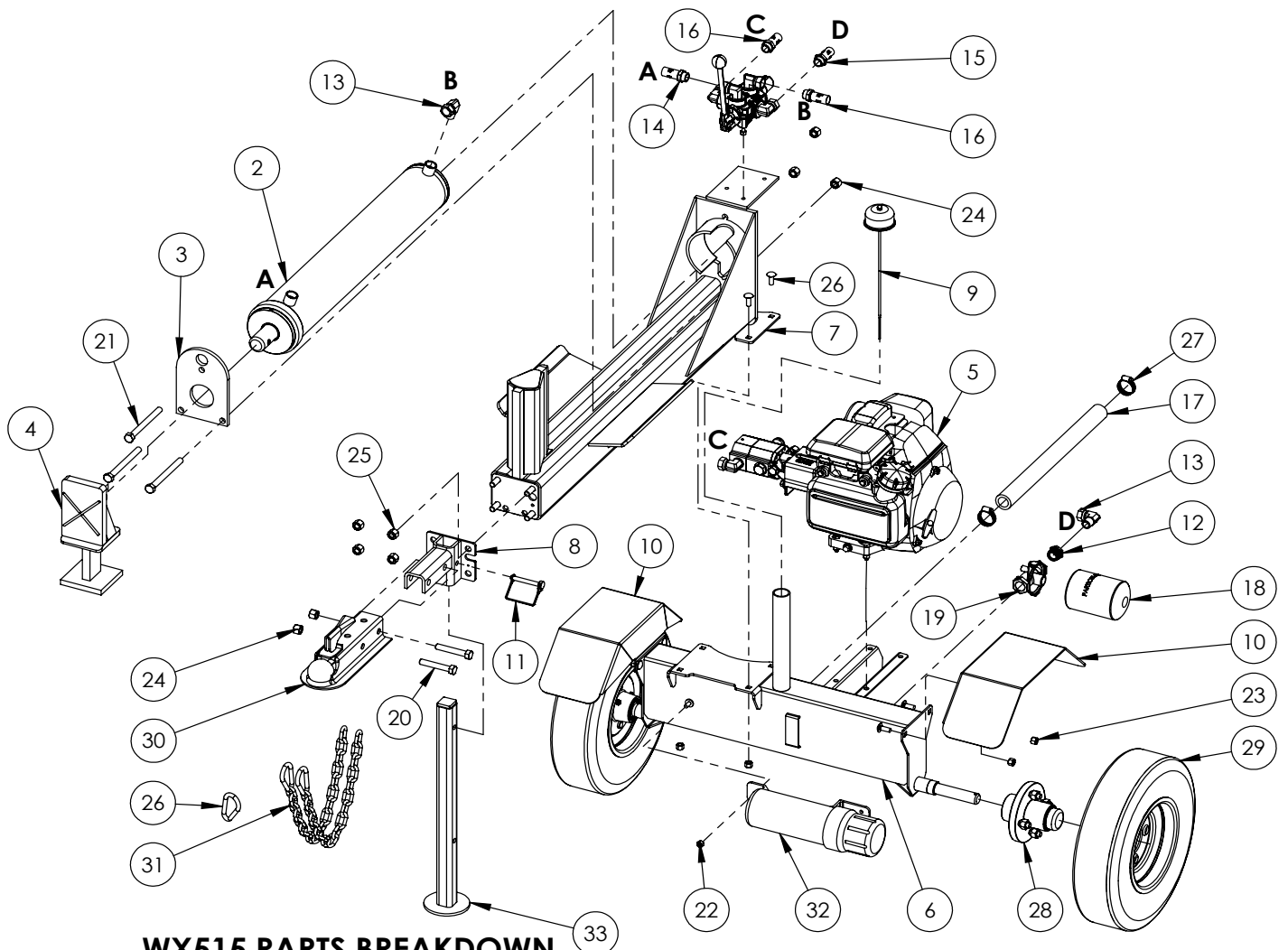

**WX515 PARTS BREAKDOWN**

ITEM	PART NO.	DESCRIPTION	QTY
2	2011C101	Cylinder, 4 x 24 x 1-1/2	1
3	2014S421	Plate, Cylinder Retaining (Bolt)	1
4	2051A101	Assembly, Push Block	1
5	2051A104	Assy, GC 5hp Engine to 11gpm Pump	1
6	2051W502	Tank Weldment, WX515	1
7	2052W702	WX520 Base	1
8	2052W704	Weldment, Hitch Mount	1
9	2054A402	Breather cap dipstick	1
10	2054W408	Weldment, Fender	2
11	Z12432	Snapper Pin 3/8 x 2-1/2	1
12	Z51221	Reducer FP x MP 1208	1
13	Z51331	Elbow 90 MP x FPX 0808	2
14	Z52301	1/2 Hose, MP08 x MP08 x 13"	1
15	Z52303	1/2 Hose, MP08 x MP08 x 33"	1
16	Z52305	1/2 Hose, MP08 x MP08 x 21"	2
17	Z52404	Suction Hose, 1" x 18"	1
18	Z55301	Oil Filter - 3/4 - Particulate	1
19	Z55302	Filter Cap, 3/4 x 3/4	1
20	Z71530	Hex Bolt 1/2NC x 3	2
21	Z71555	Hex Bolt 1/2NC x 5-1/2	3
22	Z72221	Hex Lock Nut 5/16NC	1
23	Z72231	Hex Lock Nut 3/8NC	8
24	Z72251	Hex Lock Nut 1/2NC	5
25	Z72251	Hex Lock Nut 1/2NC	4
26	Z76231	Carrige Bolt 3/8NC x 1	8
27	Z79401	Hose Clamp, # 16	2
28	Z91202	Assembly, 1000# 4-Bolt Hub	2
29	Z91301	4.80-8 LRB SportTrail	2
30	Z91614	2" Hitch Coupler	1
31	Z92303	Safety Chain 1/4 x 2'	2
32	Z96503	Manual Tube 3-1/2 Short	1
33	2054W406	Jack Stand, Front	1

ITEM	PART NO.	DESCRIPTION	QTY
40	2051S117	Cap, Push Block (Bolt)	1
41	2051W102	Push Block, Bolted	1
42	Z71325	Hex Bolt 3/8NC x 2-1/2	1
43	Z71576	Hex Bolt 1/2NF x 1-1/2	2
44	Z72231	Hex Lock Nut 3/8NC	1

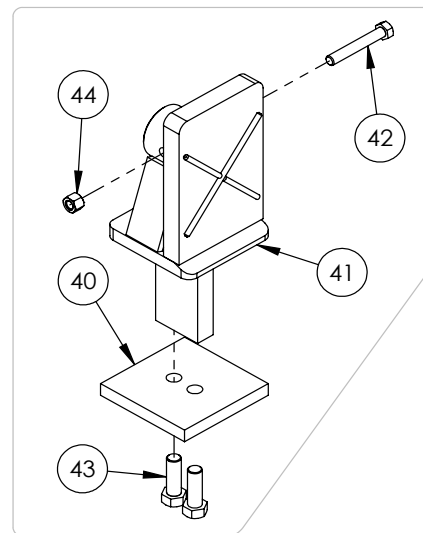

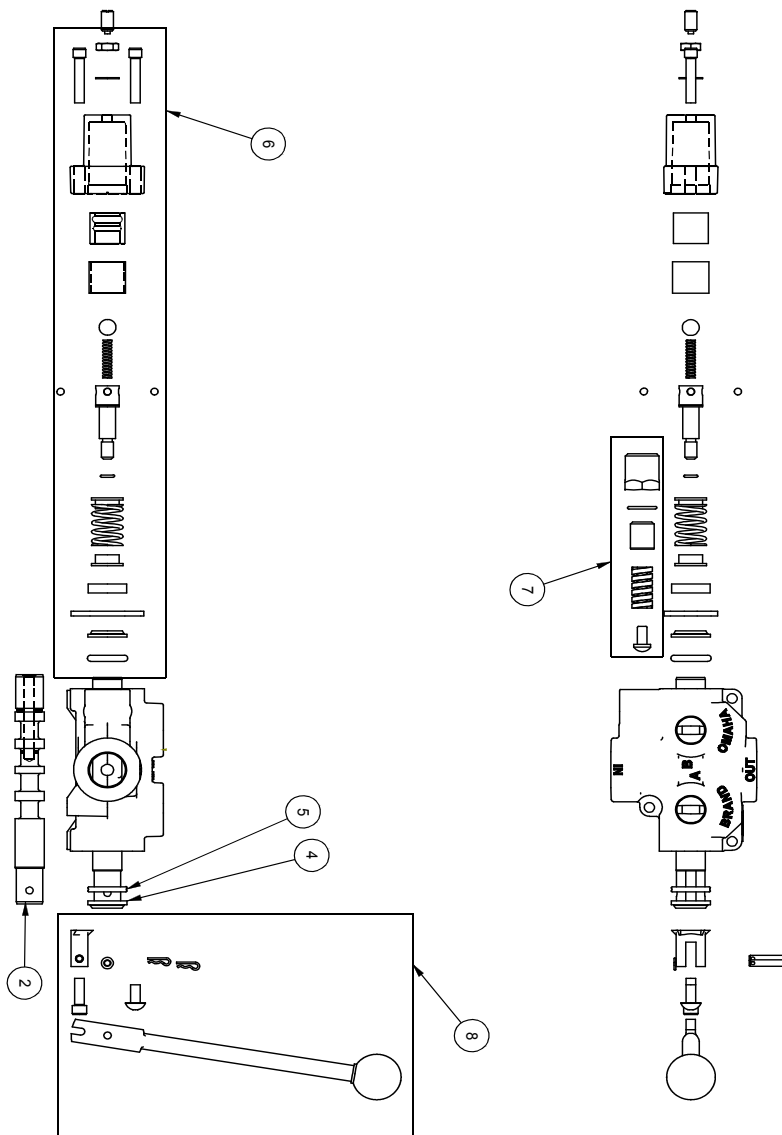

ITEM NO.	QTY.	PART NO.	DESCRIPTION
1	1	A0CASTB	AO CASTING
2	1	LS30474J	SPOOL
3	1	P1740	NAME TAG
4	1	SF305	WIPER
5	1	SF304	QUAD RING
6	1	SUB-LS	SUB-LS
		B5057	7/16 BALL
		DC7804	3/16 BALL
		SF306	RETAINER
		SF477L	SH LS ENDCAP
		XDC672	LS SLEEVE
		SF483	SPACER
		SF488	ALLEN SCREW
		SF489	CENTER STOP
		SF490	CENTERING SPRING
		SF492	HOUSING
		SF315	SPACER
		LS305	DETENT SPRING
		DC7383	O-RING 3.902
		SF498	O-RING, BLUE, METRIC
		LS306	LS WIPER
		SF502	5/16 LOCK WASHER
		SF503	PLUNGER, SPRING
		SF504	5/16 HEX JAM NUT
		SUB-R	RELIEF
		P1603	CAP NUT
		SF322	O-RING 2.016
		SF364A	ADJ. SCREW
		B505	SPRING
		SF361A	POPPET
		Z56915	HANDLE KIT
		SF377	RETAINER
		SF376	SEAL RETAINER
		SF367A	CLEVIS
		SF388	HANDLE
		SF389	PIN
		P1767	PIN CLIP
		HP5	MACH. SCREW
		SF311	KNOB
		SF308	CAP SCREW
		SF30374J	SPOOL
		P1654	WARNING TAG

ITEM NO.	QTY.	PART NO.	DESCRIPTION
1	1	B5057	7/16 BALL
2	4	DC7604	3/16 BALL
3	1	SF306	RETAINER
4	1	SF477L	SH LS ENDCAP
5	1	SF480	SD SLEEVE
6	1	SF483	SPACER
7	2	SF486	ALLEN SCREW
8	2	SF489	CENTER STOP
9	1	SF490	CENTERING SPRING
10	1	SF492	HOUSING
11	1	SF315	SPACER
12	1	LS305	DETENT SPRING
13	1	DC7583	O-RING 3-902
14	1	SF496	METRIC O-RING
15	1	LS306	LS WIPER
16	1	SF502	5/16 LOCK WASHER
17	1	SF503	SPRING PLUNGER
18	1	SF504	5/16 HEX JAM NUT

Note: This diagram is for reference only. Parts not sold separately.

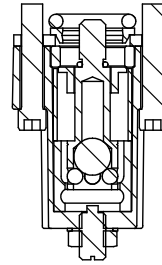
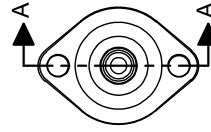
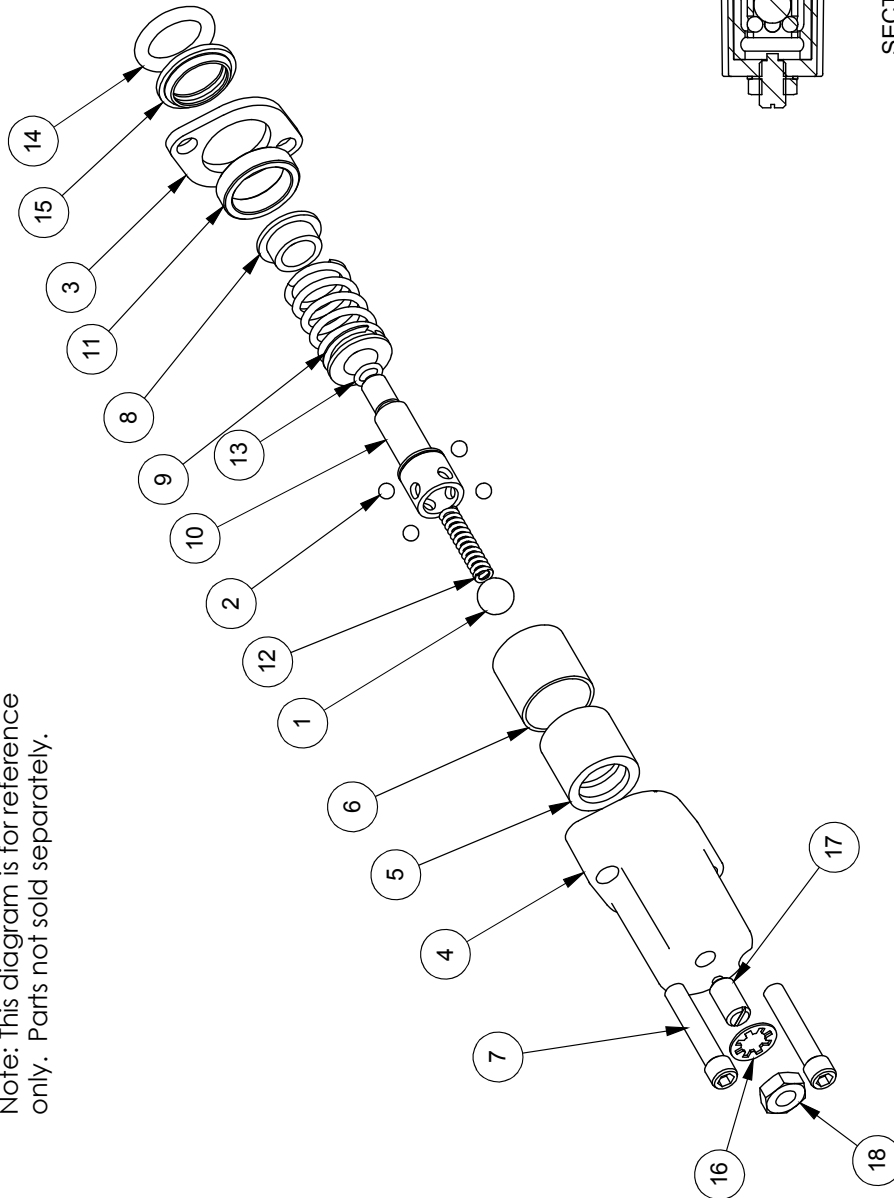

SECTION A-A

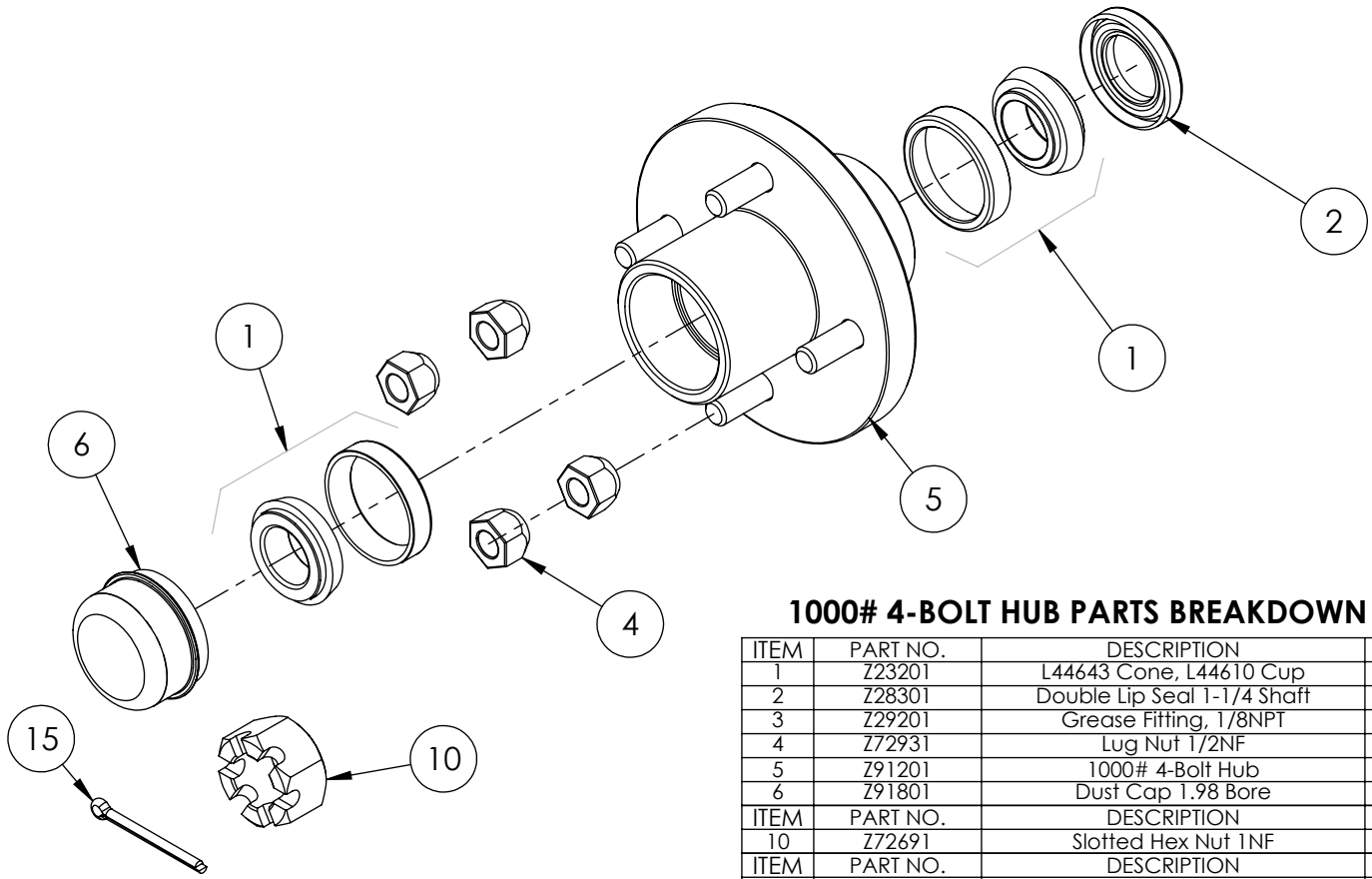

**1000# 4-BOLT HUB PARTS BREAKDOWN**

ITEM	PART NO.	DESCRIPTION	QTY
1	Z23201	L44643 Cone, L44610 Cup	2
2	Z28301	Double Lip Seal 1-1/4 Shaft	1
3	Z29201	Grease Fitting, 1/8NPT	1
4	Z72931	Lug Nut 1/2NF	4
5	Z91201	1000# 4-Bolt Hub	1
6	Z91801	Dust Cap 1.98 Bore	1
ITEM	PART NO.	DESCRIPTION	QTY
10	Z72691	Slotted Hex Nut 1NF	1
ITEM	PART NO.	DESCRIPTION	QTY
15	Z12322	Cotter Pin 3/16 X 2	1



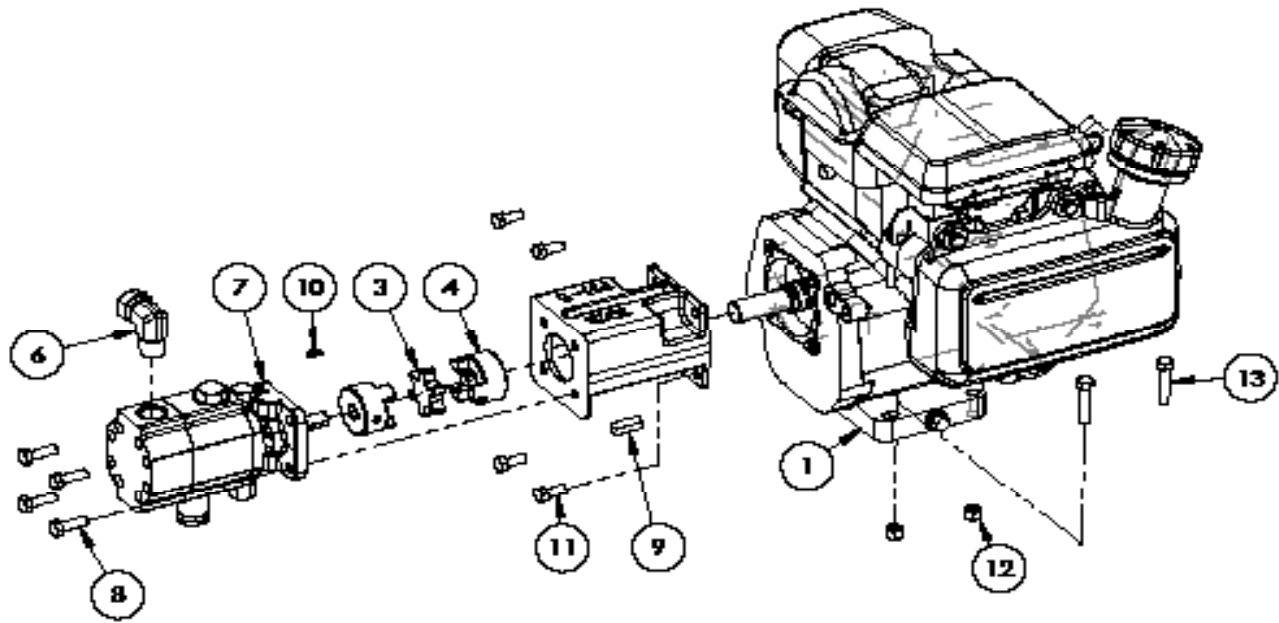

### 2051A104 PARTS BREAKDOWN

ITEM	PART NO.	DESCRIPTION	QTY
1	Z0306	Honda GC160 Engine	1
2	Z5301	Pump Mounting, PM-5	1
3	Z46408	Coupler Spider 1075	1
4	Z46406	Shaft Coupler 1075 x 3/4	1
5	Z46410	Shaft Coupler 1075 x 1/2	1
6	Z51381	Elbow 90 MP x FPK 0806	1
7	Z52204	Pump, 11 gpm Two-Stage	1
8	Z71210	Hex Bolt, 5/16NC x 1	4
9	Z46542	Key 5/16 x 5/16 x 1	1
10	Z46592	Woodruff Key, 1/8 x 1/2	1
11	Z71273	Hex Bolt, 5/16NF x 3/4	4
12	Z72221	Hex Lock Nut 5/16NC	4
13	Z71215	Hex Bolt, 5/16NC x 1-1/2	4

# WX TRAILER SPLITTER WIRING

## RIGHT SIDE

KEY	
Bl	- BLUE
Br	- BROWN
Gr	- GREEN
Rd	- RED
Yl	- YELLOW
Bk	- BLACK
Wh	- WHITE

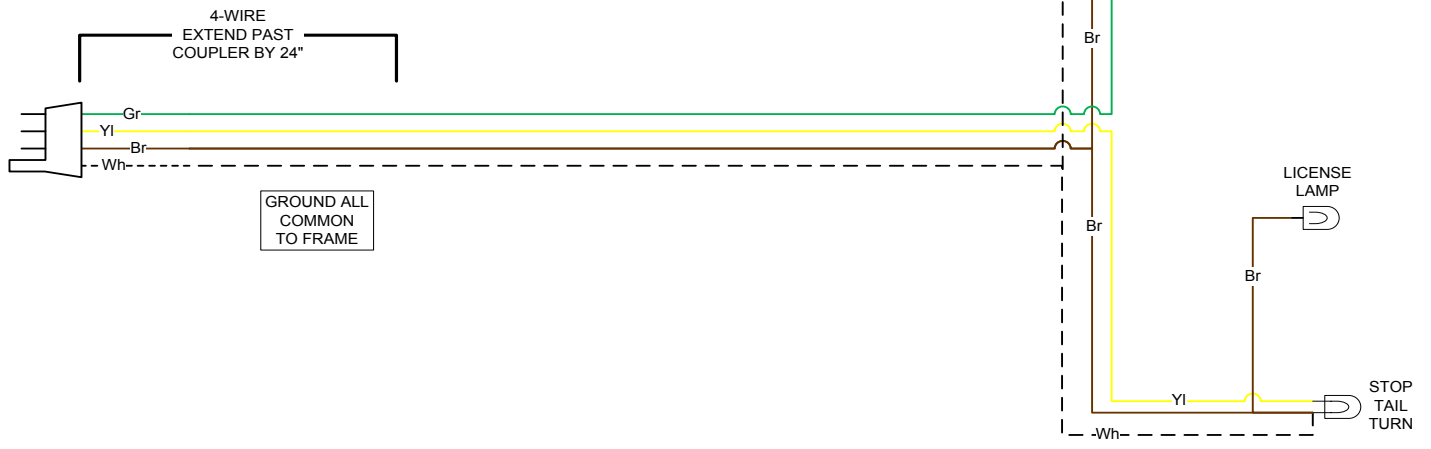

## LEFT SIDE

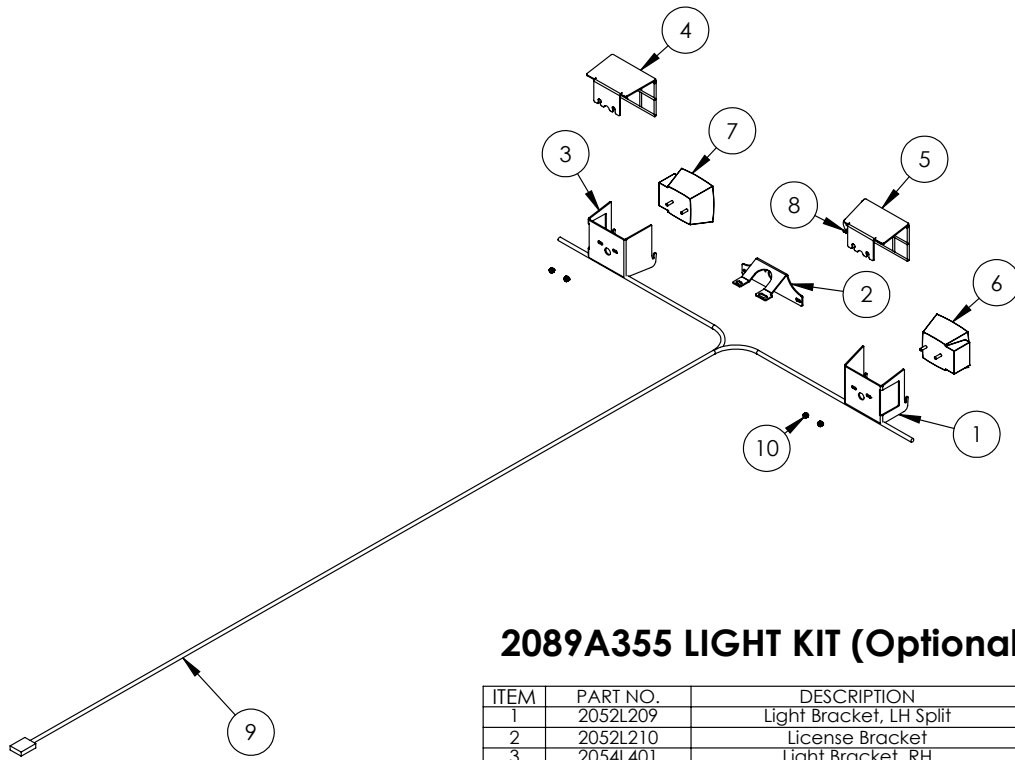

**2089A355 LIGHT KIT (Optional)**

ITEM	PART NO.	DESCRIPTION	QTY
1	2052L209	Light Bracket, LH Split	1
2	2052L210	License Bracket	1
3	2054L401	Light Bracket, RH	1
4	2054W403	Light Guard, RH	1
5	2054W404	Light Guard, LH	1
6	Z61106	Stop, Turn, Tail Light LH	1
7	Z61107	Stop, Turn, Tail Light RH	1
8	Z61301	License Lamp	1
9	Z62105	110" Wishbone Trailer Harness	1
10	Z72941	Serrated Washer Nut 1/4NC	4

## HORIZONTAL LOG SPLITTER DECAL BREAKDOWN

ITEM	PART NO.	DESCRIPTION	QTY
1	Z94039	CAUTION - Read Manual	1
2	Z94040	WARNING - Moving Wedge	2
3	Z94067	Clear Guide	2
4	Z94056	Wallenstein	2
5	Z94019	Made in Canada	3
6	Z94066	Apply Oil or Grease	1

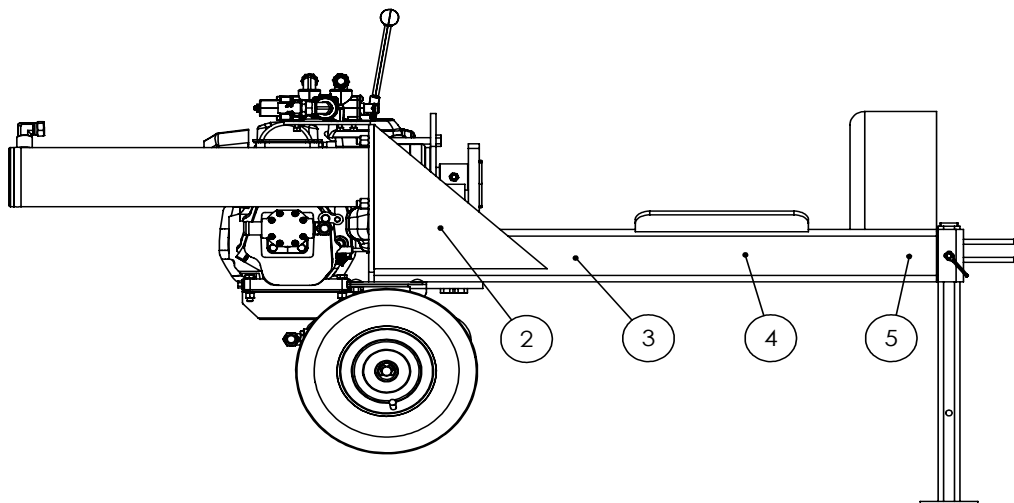
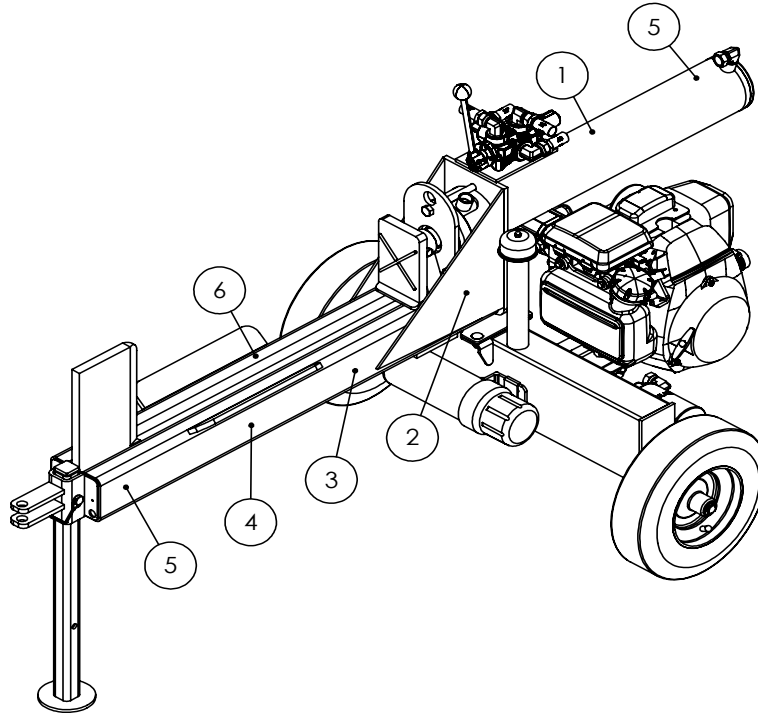

# Trailer Splitter Decals

Z94056



Z94067



Z94019



Z94066



Z94039

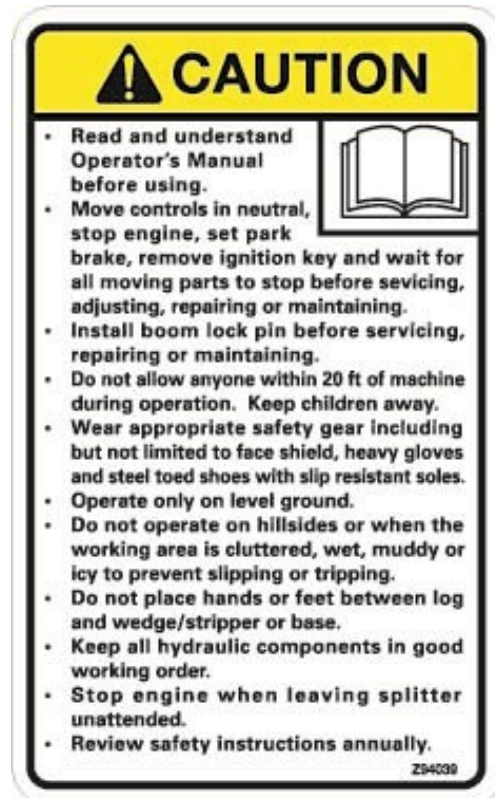

Z94040



## TWO PANEL HORIZONTAL LOG SPLITTER DECAL BREAKDOWN

ITEM	PART NO.	DESCRIPTION	QTY
1	Z94119	CAUTION - Read Manual	1
2	Z94123	Keep Feet Clear	1
3	Z94067	Clear Guide	2
4	Z94056	Wallenstein	2
5	Z94019	Made in Canada	3
6	Z94142	99 dB Sound Level	1
7	Z94124	Keep Hands Clear	1

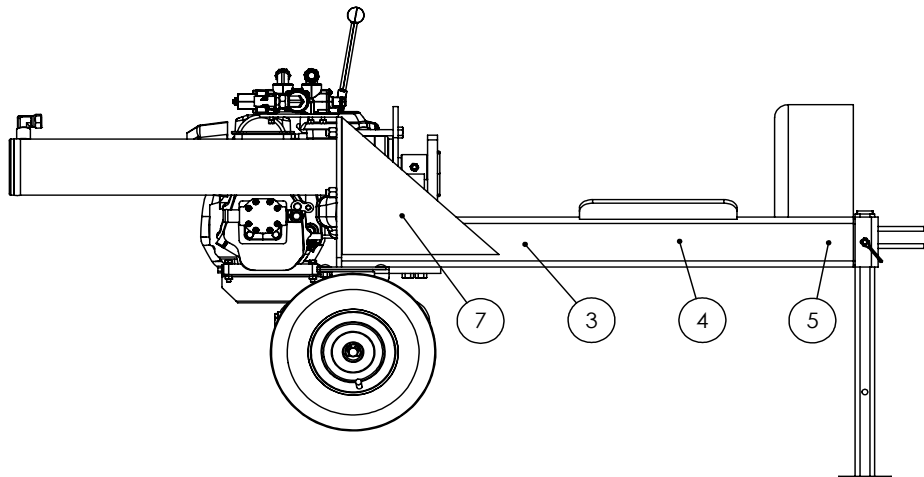
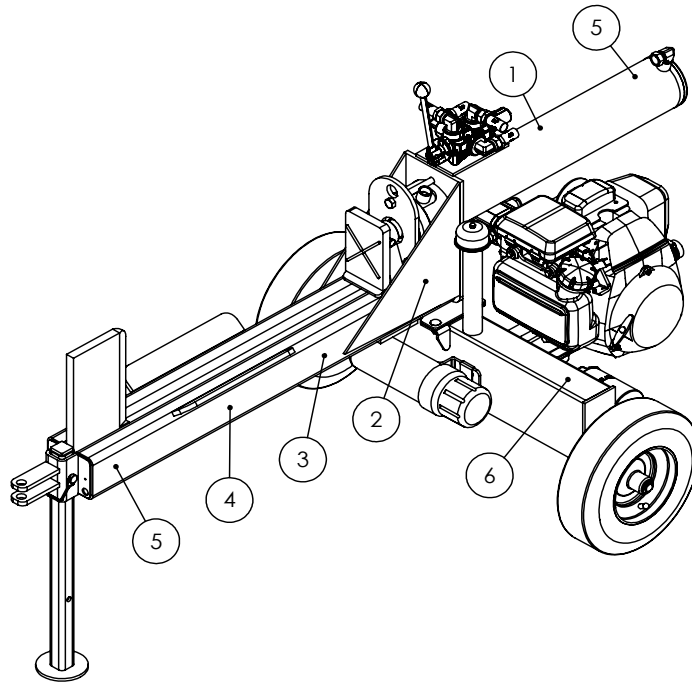

## Two Panel Trailer Splitter Decals

Z94019



Z94142



Z94067

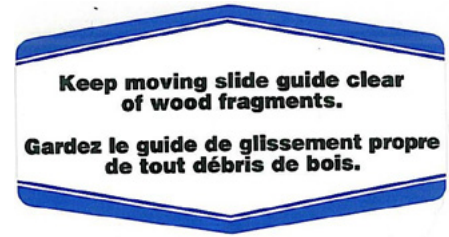

Z94056



Z94119



Z94123



Z94124





**WALLENSTEIN Products Manufactured by:**

**EMB MFG Inc.**

4144 Boomer Line  
St. Clements, Ontario  
Canada N0B 2M0  
Phone: 1-877-695-9283  
Fax: 519-699-4146  
[www.embmfg.com](http://www.embmfg.com)