



EMB Manufacturing Inc.  
4144 Boomer Line · St. Clements, On · N0B 2M0 · Canada  
Ph: (519) 699-9283 · Fax: (519) 699-4146  
[www.wallensteinequipment.com](http://www.wallensteinequipment.com)

# WX520 Trailer Log Splitter

## Parts Manual

Starting with S/N's  
**2E9US111ES250328 and on**  
**250328 and on**

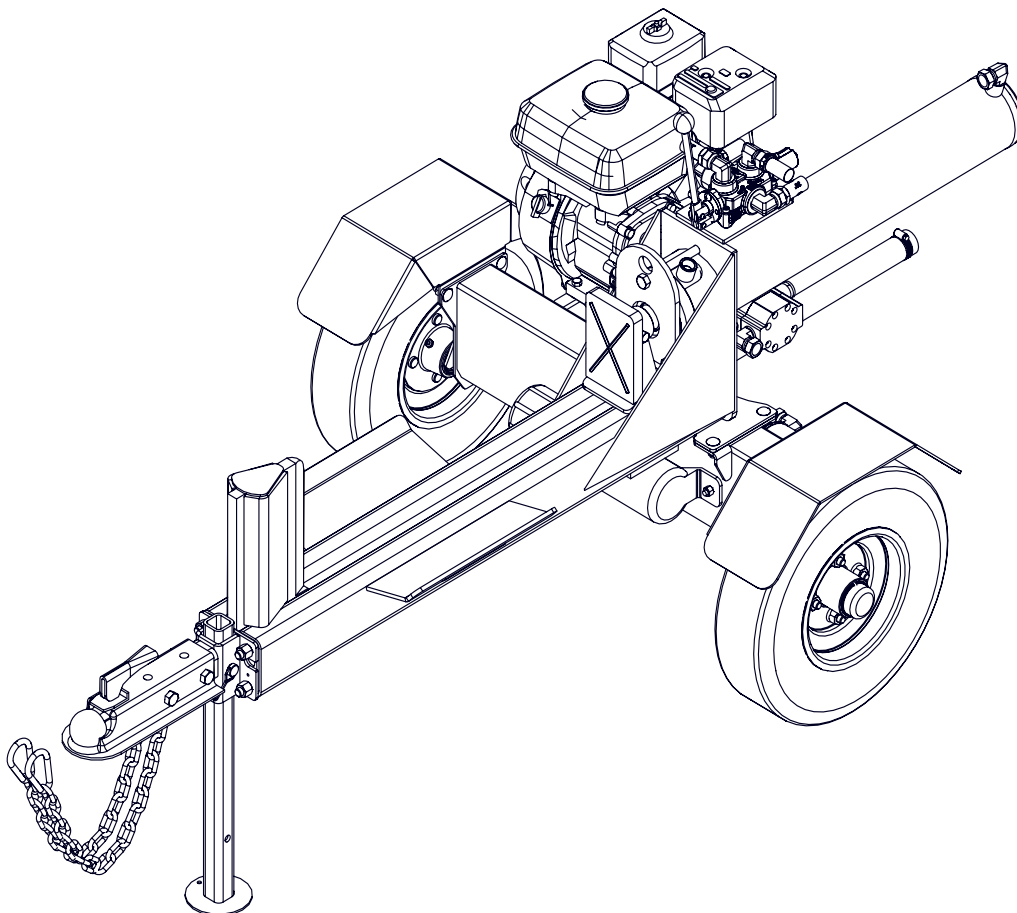

Refer to the operators  
manual for safe  
operation and  
maintenance

## Foreword

EMB Mfg. has prepared this parts manual to assist customers in ordering quality OEM replacement parts.

Proper and regular service and replacing old, worn or broken parts with the correct OEM parts are essential to prolonging the life of your EMB product. Please refer to this manual before ordering any replacement parts.

All information contained in this parts manual is based on the latest product specification available at the time of printing this manual. If your product differs from the specifications contained within this manual contact EMB Mfg. for information.

EMB reserves the right to alter specifications on their products at any time.

Reproduction of this parts manual of any kind is prohibited without prior written permission from EMB Mfg.

For parts and information please contact your dealer. If your dealer is no longer available please go to our website: <http://www.wallensteinequipment.com> and click on "FIND A DEALER NEAR YOU" for information on a local dealer.

## Table of Contents Page

<b>Bolt Torque.....</b>	<b>4</b>
<b>Hydraulic Fitting Torque .....</b>	<b>5</b>
<b>Wheel Lug Torque .....</b>	<b>5</b>
<b>Main Parts.....</b>	<b>6</b>
<b>Splitter Base.....</b>	<b>7</b>
<b>Splitter Tank.....</b>	<b>8</b>
<b>Hitch Assembly .....</b>	<b>9</b>
<b>Hub Assembly.....</b>	<b>10</b>
<b>Engine and Hydraulics Assembly .....</b>	<b>10</b>
<b>Cylinder Assembly .....</b>	<b>11</b>
<b>Valve Assembly.....</b>	<b>11</b>
<b>Valve Seal Kit.....</b>	<b>12</b>
<b>Hydraulic Hose List .....</b>	<b>12</b>
<b>Hydraulic Schematic .....</b>	<b>13</b>
<b>Label Layout.....</b>	<b>14</b>
<b>Accessories.....</b>	<b>15</b>

Maintenance should be performed by  
trained personnel only.



Refer to the operators  
manual for safe  
operation and  
maintenance

**Bolt Torque**

**CHECKING BOLT TORQUE**

The tables shown below give correct torque values for various bolts and capscrews. Tighten all bolts to the torques specified in chart unless otherwise noted. Check tightness of bolts periodically, using bolt torque chart as a guide. Replace hardware with the same strength bolt.

**ENGLISH TORQUE SPECIFICATIONS**

Bolt Diameter "A"	Bolt Torque*					
	SAE 2 (N.m) (lb-ft)		SAE 5 (N.m) (lb-ft)		SAE 8 (N.m) (lb-ft)	
1/4"	8	6	12	9	17	12
5/16"	13	10	25	19	36	27
3/8"	27	20	45	33	63	45
7/16"	41	30	72	53	100	75
1/2"	61	45	110	80	155	115
9/16"	95	60	155	115	220	165
5/8"	128	95	215	160	305	220
3/4"	225	165	390	290	540	400
7/8"	230	170	570	420	880	650
1"	345	225	850	630	1320	970

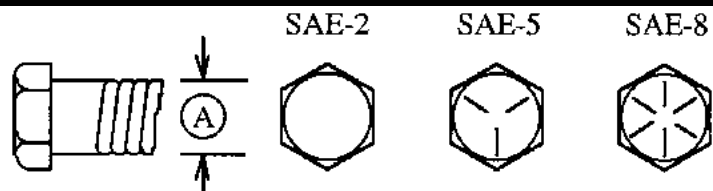

**METRIC TORQUE SPECIFICATIONS**

Bolt Diameter "A"	Bolt Torque*			
	8.8 (N.m) (lb-ft)		10.9 (N.m) (lb-ft)	
M3	0.5	0.4	1.8	1.3
M4	3	2.2	4.5	3.3
M5	6	4	9	7
M6	10	7	15	11
M8	25	18	35	26
M10	50	37	70	52
M12	90	66	125	92
M14	140	103	200	148
M16	225	166	310	229
M20	435	321	610	450
M24	750	553	1050	774
M30	1495	1103	2100	1550
M36	2600	1917	3675	2710

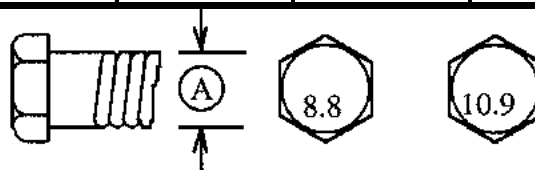

Torque figures indicated above are valid for non-greased or non-oiled threads and heads unless otherwise specified. Therefore, do not grease or oil bolts or capscrews unless otherwise specified in this manual. When using locking elements, increase torque values by 5%.

\* Torque value for bolts and capscrews are identified by their head markings.

### Hydraulic Fitting Torque

#### Tightening Flare Type Tube Fittings \*

1. Check flare and flare seat for defects that might cause leakage.
2. Align tube with fitting before tightening.
3. Lubricate connection and hand tighten swivel nut until snug.
4. To prevent twisting the tube(s), use two wrenches. Place one wrench on the connector body and with the second tighten the swivel nut to the torque shown.

Tube Size OD (in.)	Nut Size Across Flats (in.)	Torque Value*		Recommended Turns To Tighten (After Finger Tightening)	
		(N.m)	(lb-ft)	(Flats)	(Turn)
3/16	7/16	8	6	1	1/6
1/4	9/16	12	9	1	1/6
5/16	5/8	16	12	1	1/6
<b>3/8</b>	<b>11/16</b>	<b>24</b>	<b>18</b>	<b>1</b>	<b>1/6</b>
1/2	7/8	46	34	1	1/6
5/8	1	62	46	1	1/6
3/4	1-1/4	102	75	3/4	1/8
7/8	1-3/8	122	90	3/4	1/8

The torque values shown are based on lubricated connections as in reassembly.

### Wheel Lug Torque

It is extremely important safety procedure to apply and maintain proper wheel mounting torque on your trailer axle. Torque wrenches are the best method to assure the proper amount of torque is being applied to a fastener.

Wheel lugs should be torqued before first road use and after each wheel removal. Check and re torque after the first 16Km (10 miles), 40Km (25 miles), and again at 80Km (50 miles). Check periodically thereafter.

Note: Wheel lugs must be applied and maintained at the proper torque levels to prevent loose wheels, broken studs, and possible dangerous separation of wheels from your axle.

- Start all lugs by hand to prevent cross threading.
- Tighten lugs in sequence, per wheel lug torque sequence chart.
- The tightening of the fasteners should be done in stages. Following the recommended sequence, tighten fasteners per wheel torque requirements chart.

#### Wheel Torque Requirements

Wheel Size	Torque Unit	1st Stage	2nd Stage	3rd Stage
8"	ft-lbs	12 - 20	30 - 35	45 - 55
	Nm	16 - 26	39 - 45.5	58.5 - 71.5
12"	ft-lbs	20 - 25	35 - 40	50 - 60
	Nm	26 - 32.5	45.5 - 52	65 - 78
13"	ft-lbs	20 - 25	35 - 40	50 - 60
	Nm	26 - 32.5	45.5 - 52	65 - 78
14"	ft-lbs	20 - 25	50 - 60	90 - 120
	Nm	26 - 32.5	65 - 78	117 - 156
15"	ft-lbs	20 - 25	50 - 60	90 - 120
	Nm	26 - 32.5	65 - 78	117 - 156
16"	ft-lbs	20 - 25	50 - 60	90 - 120
	Nm	26 - 32.5	65 - 78	117 - 156

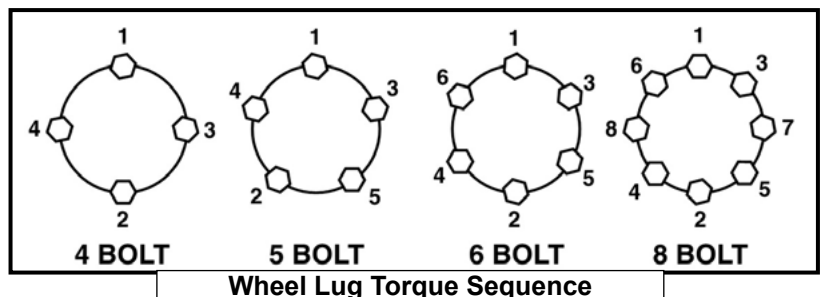

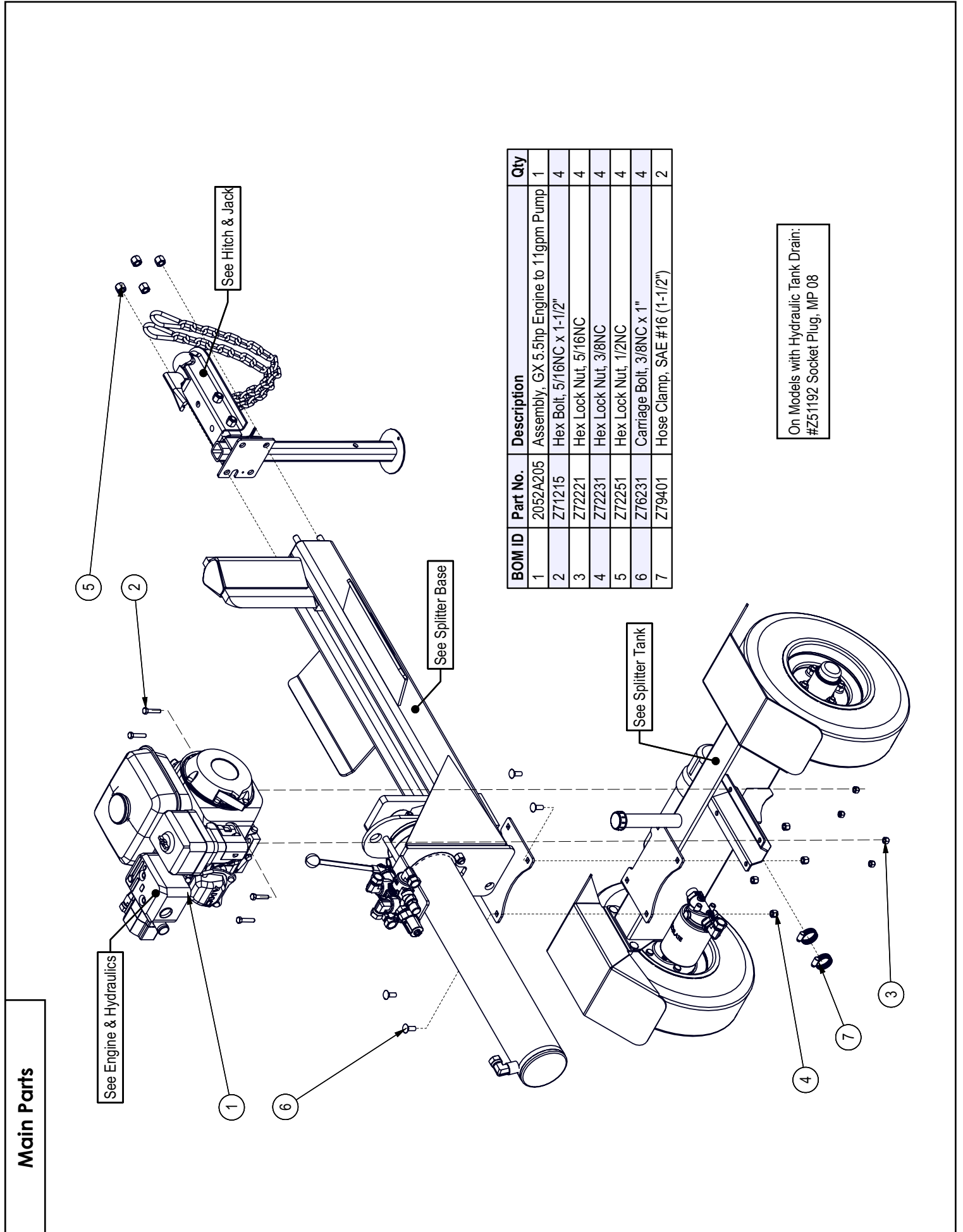

**Splitter Base**

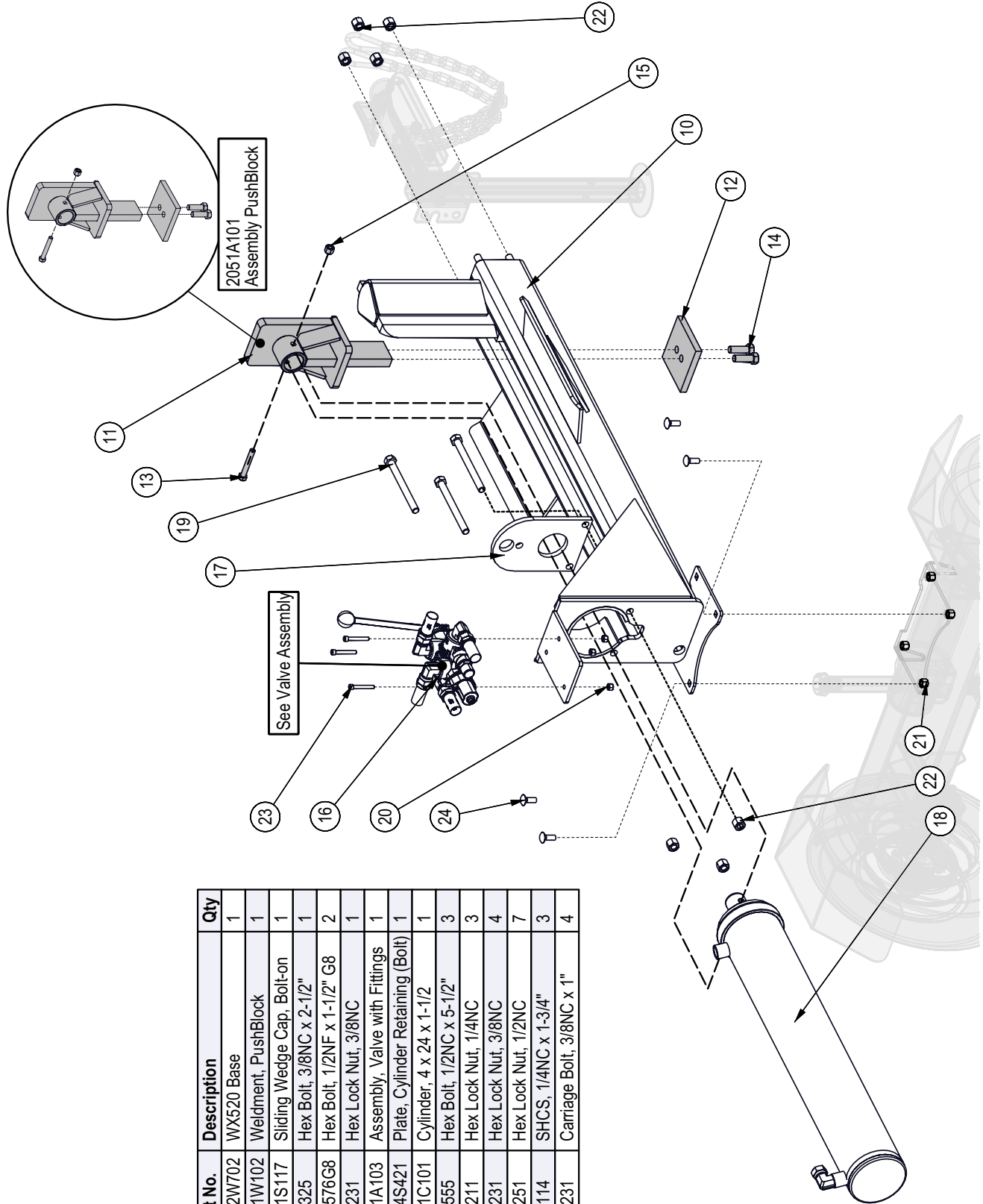

BOM ID	Part No.	Description	Qty
10	2052W702	WX520 Base	1
11	2051W102	Weldment, PushBlock	1
12	2051S117	Sliding Wedge Cap, Bolt-on	1
13	Z71325	Hex Bolt, 3/8NC x 2-1/2"	1
14	Z71576G8	Hex Bolt, 1/2NF x 1-1/2" G8	2
15	Z72231	Hex Lock Nut, 3/8NC	1
16	2011A103	Assembly, Valve with Fittings	1
17	2014S421	Plate, Cylinder Retaining (Bolt)	1
18	2011C101	Cylinder, 4 x 24 x 1-1/2"	1
19	Z71555	Hex Bolt, 1/2NC x 5-1/2"	3
20	Z72211	Hex Lock Nut, 1/4NC	3
21	Z72231	Hex Lock Nut, 3/8NC	4
22	Z72251	Hex Lock Nut, 1/2NC	7
23	Z75114	SHCS, 1/4NC x 1-3/4"	3
24	Z76231	Carriage Bolt, 3/8NC x 1"	4

**Splitter Tank**

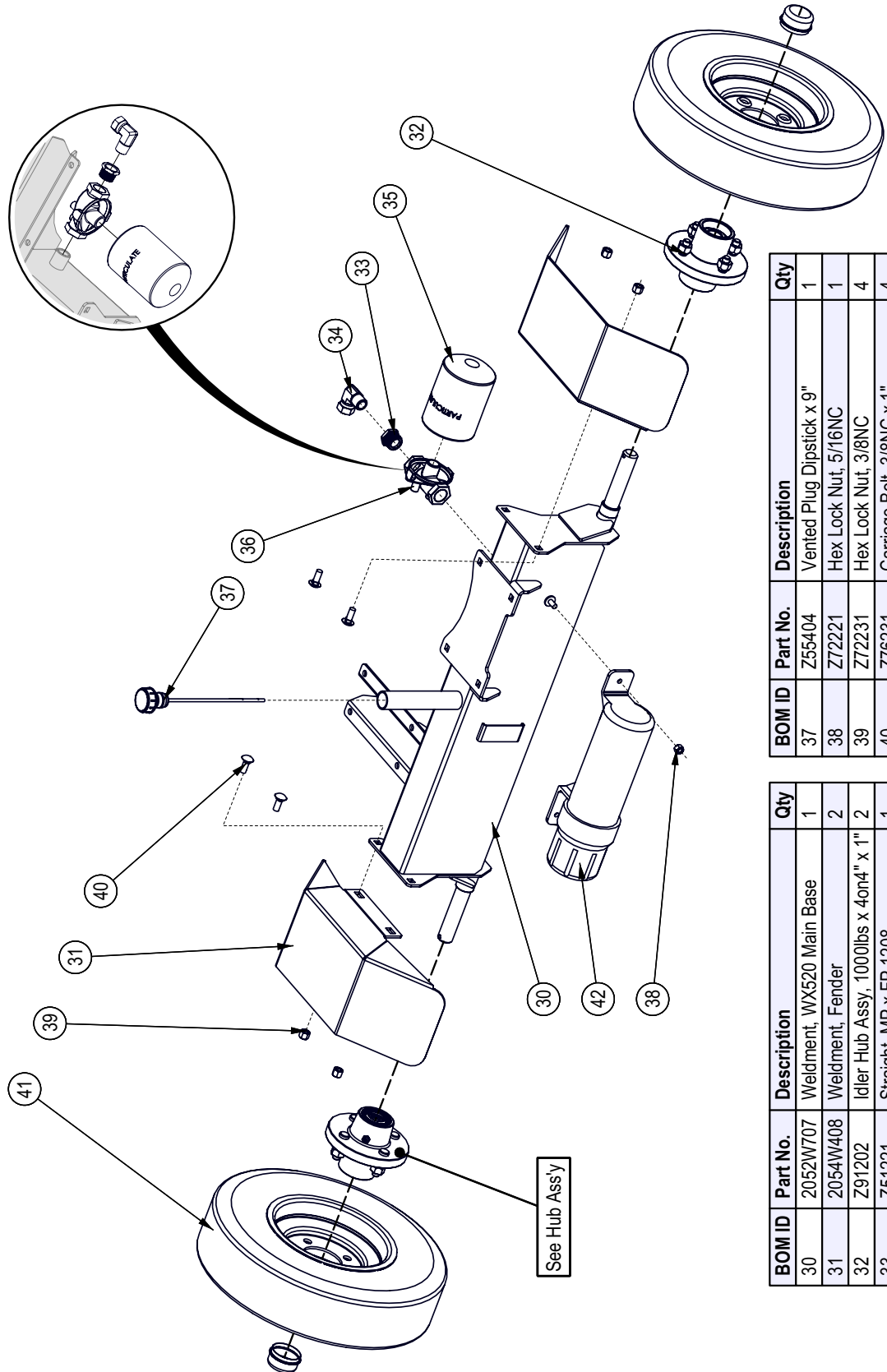

BOM ID	Part No.	Description	Qty
37	Z55404	Vented Plug Dipstick x 9"	1
38	Z72221	Hex Lock Nut, 5/16NC	1
39	Z72231	Hex Lock Nut, 3/8NC	4
40	Z76231	Carriage Bolt, 3/8NC x 1"	4
41	Z91301	4.80-8 LRB SportTrail 4on4"	2
42	Z96503	Manual Tube, 3-1/2" Short	1

BOM ID	Part No.	Description	Qty
30	2052W707	Weldment, WX520 Main Base	1
31	2054W408	Weldment, Fender	2
32	Z91202	Idler Hub Assy, 1000lbs x 4on4" x 1"	2
33	Z51221	Straight, MP x FP 1208	1
34	Z51331	Elbow 90, MP x FPX 0808	1
35	Z55301	Particulate Filter, FP12	1
36	Z55302	Filter Cap, MP12 x FP12	1



**Hitch Assembly**

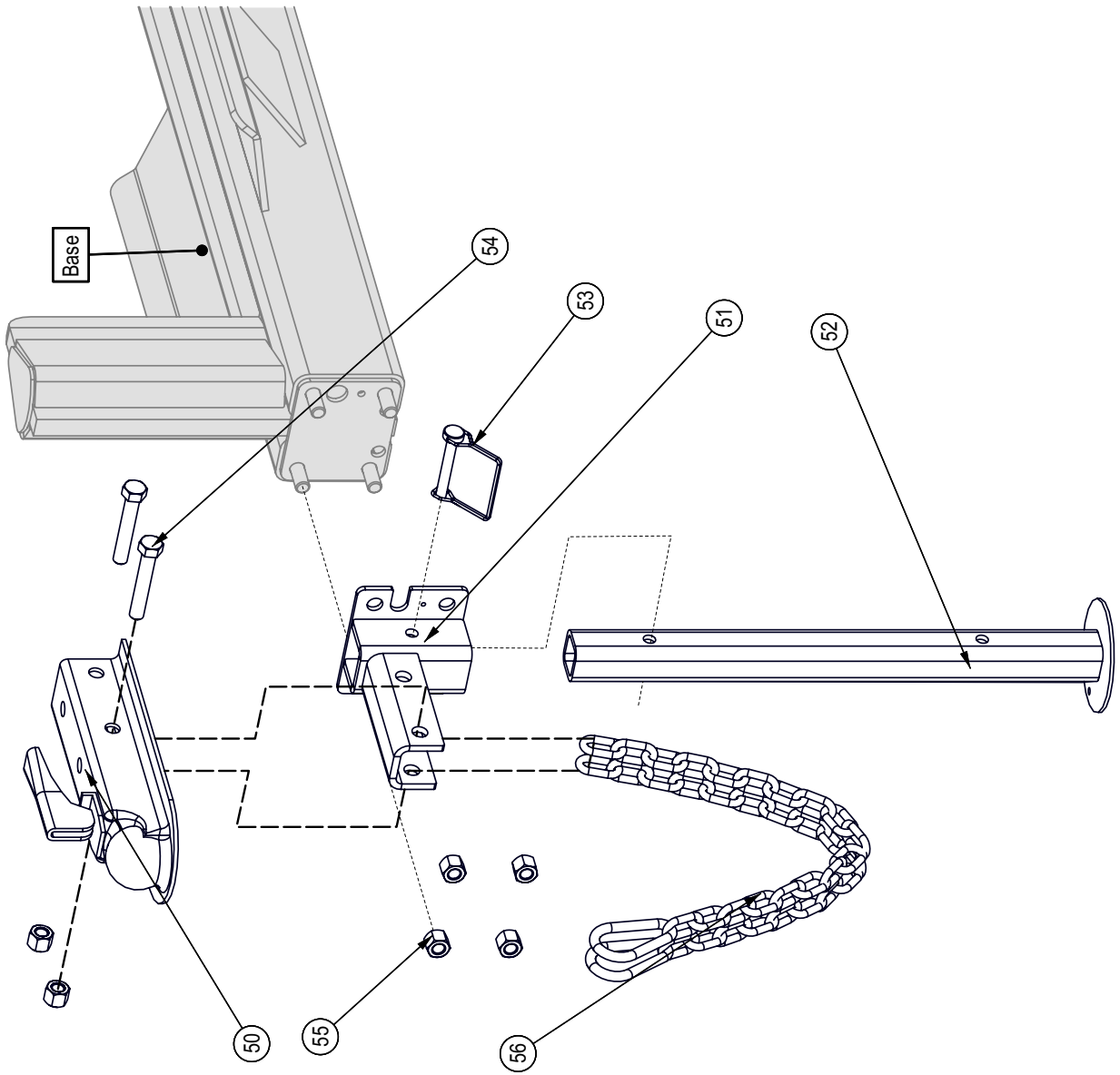

BOM ID	Part No.	Description	Qty
50	Z91614	Hitch Coupler, 2" Ball x 2" x 3500lbs	1
51	2052W704	Weldment, Hitch Mount	1
52	2052W206	Jack Stand, Front	1
53	Z12432	Snap Lock Pin, 3/8" x 2-1/2"	1
54	Z71530	Hex Bolt, 1/2NC x 3"	2
55	Z72251	Hex Lock Nut, 1/2NC	6
56	Z92303	Safety Chain, 1/4" x 2ft with Snap	2

### Hub Assembly

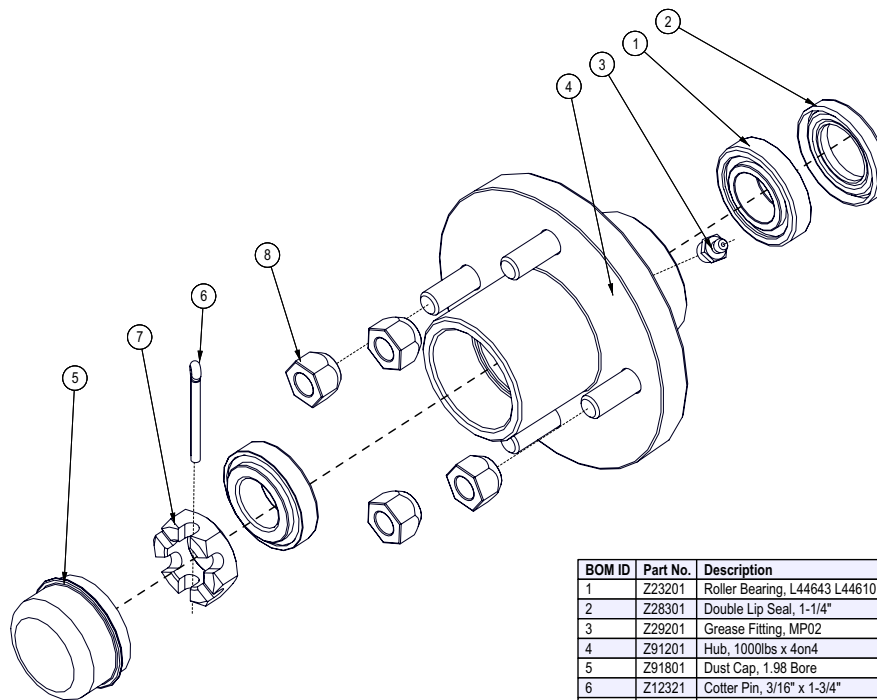

BOM ID	Part No.	Description	Qty
1	Z23201	Roller Bearing, L44643 L44610	2
2	Z28301	Double Lip Seal, 1-1/4"	1
3	Z29201	Grease Fitting, MP02	1
4	Z91201	Hub, 1000lbs x 4on4	1
5	Z91801	Dust Cap, 1.98 Bore	1
6	Z12321	Cotter Pin, 3/16" x 1-3/4"	1
7	Z72691	Castle Nut, 1NF x 9/16" Thick	1
8	Z72931	Lug Nut, 1/2NF	4

### Engine and Hydraulics Assembly

BOM ID	Part No.	Description	Qty
1	Z46406	Shaft Coupler, L075 x 3/4"	1
2	Z46408	Spider, L075	1
3	Z46410	Shaft Coupling, L075 x 1/2"	1
4	Z46521	Key, 3/16" x 3/16" x 7/8"	1
5	Z46592	Woodruff Key, 1/8" x 1/2"	1
6	Z47126	Honda GX160UTQH6, Rope	1
7	Z51331	Elbow 90, MP x FPX 0808	1
8	Z53204	Two-Stage Pump, 11GPM	1
9	Z53801	Pump Mount, PM-5	1
10	Z71210	Hex Bolt, 5/16NC x 1"	4
11	Z71273	Hex Bolt, 5/16NF x 3/4"	4
12	Z72221	Hex Lock Nut, 5/16NC	4
13	Z71215	Hex Bolt, 5/16NC x 1-1/2"	4

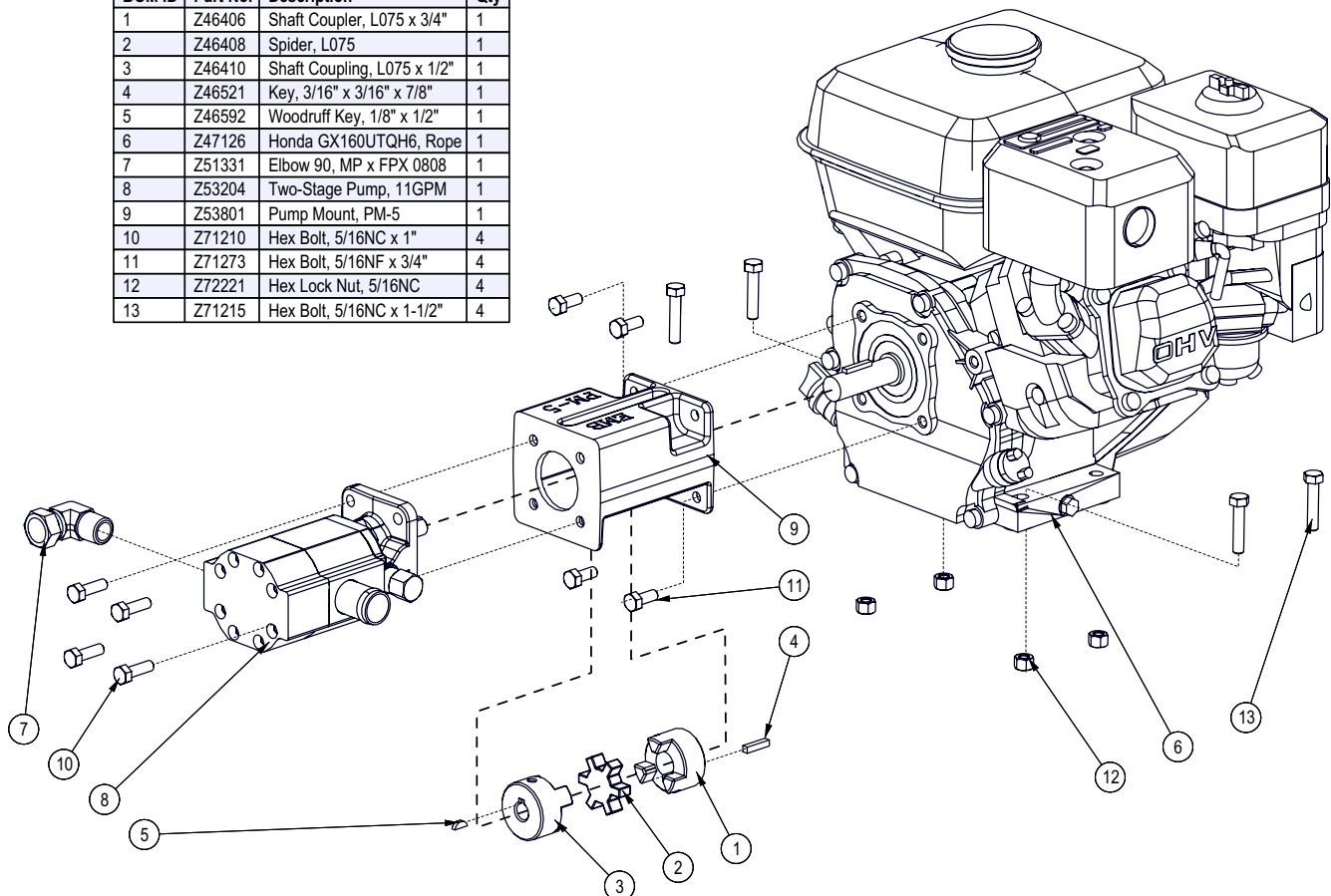

### Cylinder Assembly

#### Seal Kit #SLK-4015

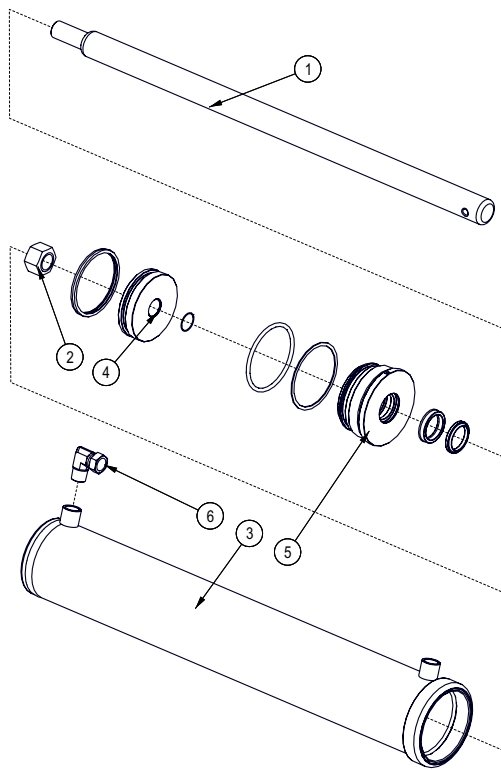

BOM ID	Part No.	Description	Qty
1	2011C1012	Rod, 1-1/2 x 1	1
2	Z72292G8	Hex Lock Nut 1NF Grade 8	1
3	2011C1014	Barrel, 4"	1
4	P100-400SP	Piston, 4" Bore	1
5	G400-150S	Gland, 4" x 1-1/2"	1
6	Z51331	Elbow 90, MP x FPX 0808	1

### Valve Assembly

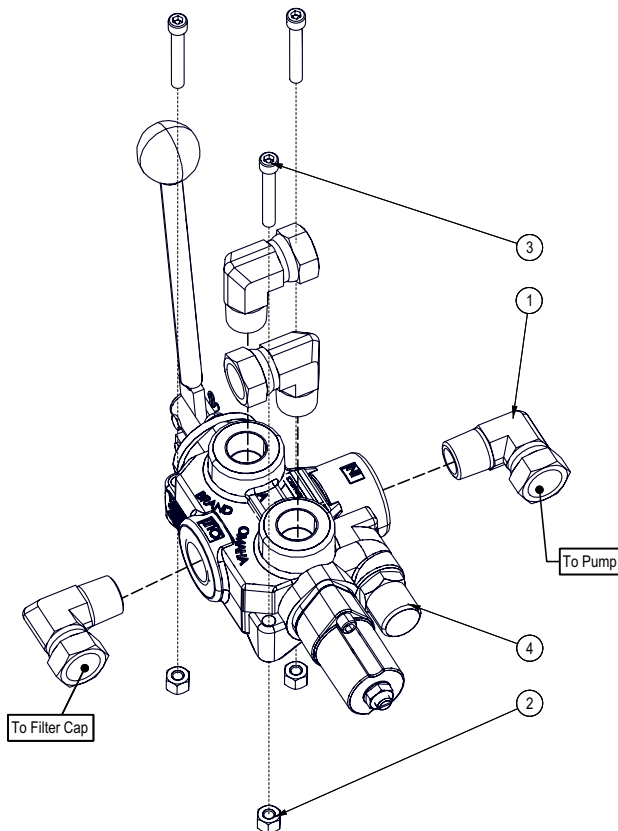

BOM ID	Part No.	Description	Qty
1	Z51331	Elbow 90, MP x FPX 0808	4
2	Z72211	Hex Lock Nut, 1/4NC	3
3	Z75114	SHCS, 1/4NC x 1-3/4"	3
4	Z56209	Single Spool Valve, OC Tandem SCDK x 18GPM	1

**Valve Seal Kit**

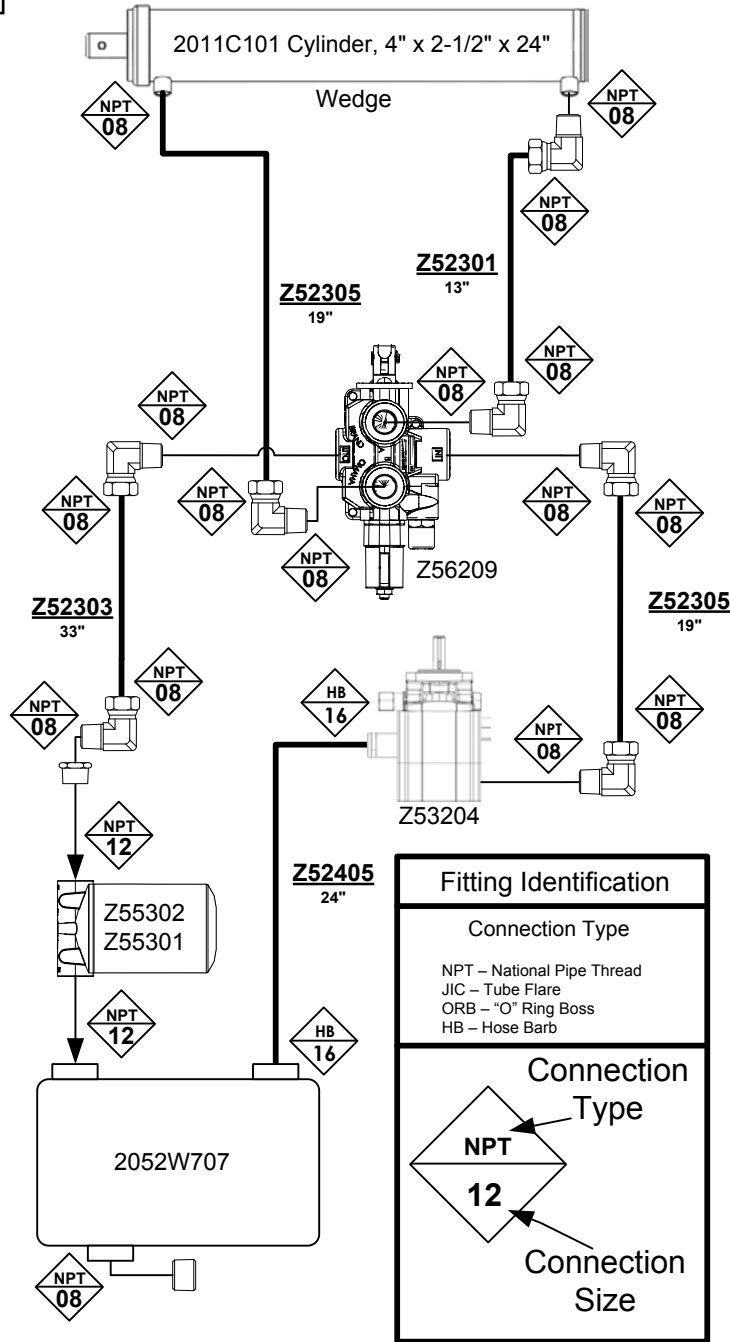

**Hydraulic Hose List**

Part No.	Description	Qty
Z52405	Suction Hose, 1 x 24	1
Z52301	1/2" Hose, MP08 x MP08 x 13	1
Z52305	1/2" Hose, MP08 x MP08 x 19	2
Z52303	1/2" Hose, MP08 x MP08 x 33	1

**Hydraulic Schematic**

Label Layout



WX520 Z94681 x 2



Z94239 x 1



Z94428 x 2

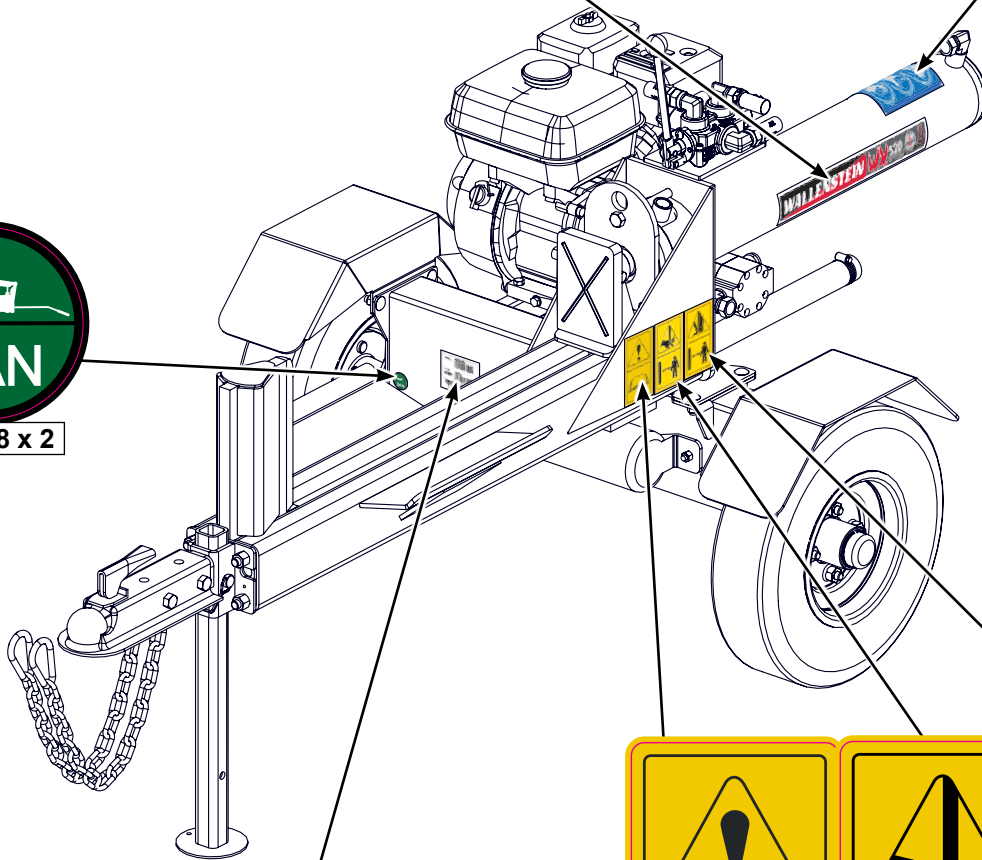

MODEL: #####

SERIAL NUMBER: #####

WALLENSTEIN [www.embmfg.com](http://www.embmfg.com)  
 EMB MFG INC, 4144 BOOMER LINE,  
 ST CLEMENTS, ON N0B 2M0 CANADA

Serial Location



Z94119 x 2



Z94124 x 2



Z94123 x 2

**Accessories**

Call your dealer for pricing and availability

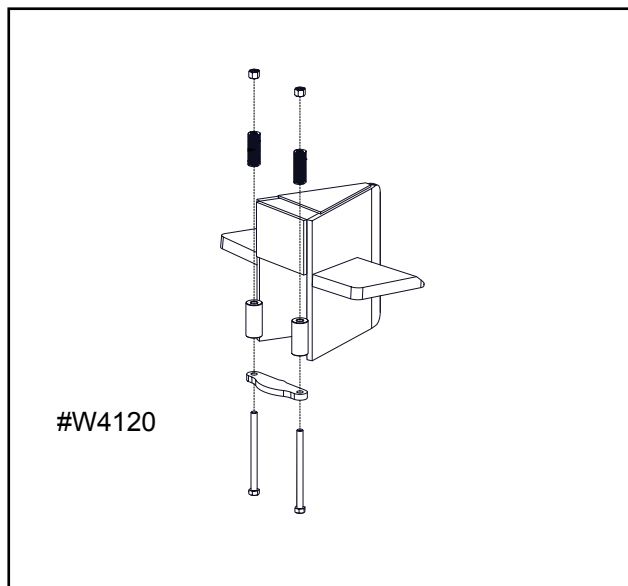

#W4120

**#W4120 4 Way Wedge**

Boost your productivity and make quick work out of logs by splitting four pieces at once. This is an ideal way to save time.

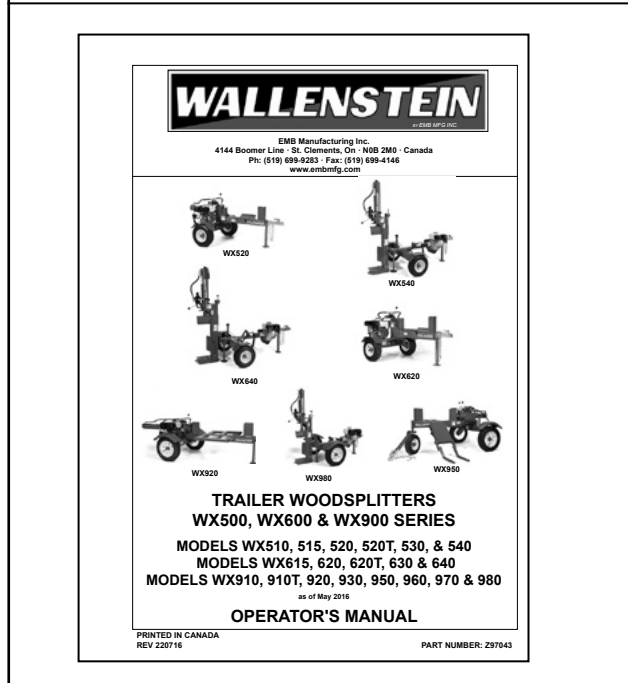

**#Z97043  
TRAILER WOODSPLITTER  
OPERATOR'S MANUAL**

Available as a download at  
[www.wallensteinequipment.com](http://www.wallensteinequipment.com)