

# OPERATOR'S MANUAL

---

## **BXS** Series **3PH Self-feed Chipper**

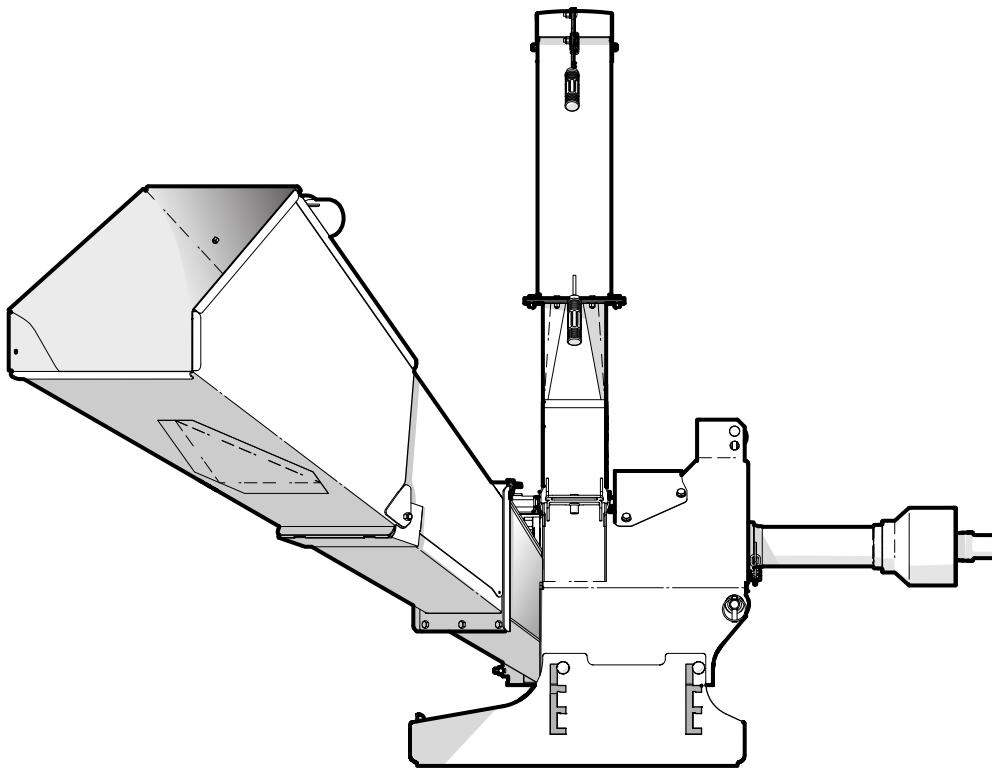

# 1. Foreword

## 1.1 Introduction

Congratulations on your choice of a Wallenstein **BXS Series Self-feed Chipper!**

This manual covers all of the BXS Series models:

- **BX36S**
- **BX52S**
- **BX72S**
- **BX102S**

Safe, efficient and trouble free operation of this Wallenstein product requires that anyone using or maintaining the machine reads and understands the Safety, Operation, Maintenance information contained within the Operator's Manual.

Keep this manual handy for frequent reference and to pass on to new operators or owners. Call your Wallenstein dealer or the Distributor if you need assistance, information or additional copies of the manuals.

Units of measurement in Wallenstein Equipment technical manuals are written as:  
US Customary (SI metric)

**Wallenstein Equipment Inc. • © 2021. All rights reserved.**

No part of this work may be copied, reproduced, replaced, distributed, published, displayed, modified, or transferred in any form or by any means except with the prior permission of Wallenstein Equipment Inc.

### **WARNING!**

**Do not attempt to start or operate the machine without thoroughly reviewing this manual for safe and proper operation.**

**Always keep this manual with the machine.**

W034

## Model Configuration

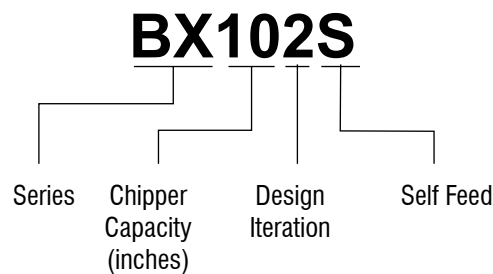

WallensteinEquipment.com

## Table of Contents

<b>1. Foreword .....</b>	<b>2</b>	<b>8. Service and Maintenance.....</b>	<b>32</b>
1.1 Introduction .....	2	8.1 Grease Type .....	32
1.2 Delivery Inspection Report.....	4	8.2 Maintenance Schedule .....	33
1.3 Serial Number Location .....	5	8.3 Grease Points .....	33
1.4 Types of Decals on the Machine .....	6	8.4 PTO Shaft Maintenance .....	35
<b>2. Safety .....</b>	<b>7</b>	8.5 Twig Breaker.....	35
2.1 Safety Alert Symbol .....	7	8.6 Rotor Blades .....	36
2.2 Signal Words .....	7	8.7 Ledger Knife .....	36
2.3 Why SAFETY is Important.....	7	<b>9. Troubleshooting.....</b>	<b>39</b>
2.4 Safety Rules .....	8	<b>10. Specifications .....</b>	<b>40</b>
2.5 Equipment Safety Guidelines .....	8	10.1 Machine Specifications .....	40
2.6 Safe Condition .....	9	10.2 Common Bolt Torque Values.....	41
2.7 Sign-Off Form .....	10	<b>11. Product Warranty .....</b>	<b>42</b>
<b>3. Safety Signs .....</b>	<b>11</b>	<b>12. Alphabetical Index .....</b>	<b>43</b>
3.1 Safety Sign Locations .....	11		
3.2 Safety Sign Explanations.....	13		
3.3 Replace Damaged Safety Signs.....	14		
<b>4. Familiarization.....</b>	<b>15</b>		
4.1 To the New Operator or Owner .....	15		
4.2 Operator Orientation .....	15		
4.3 Machine Components.....	16		
<b>5. Attach to a Tractor .....</b>	<b>18</b>		
5.1 Connect 3-point Hitch .....	18		
5.2 Size PTO Shaft Length .....	19		
5.3 Install PTO Shaft.....	22		
<b>6. Controls .....</b>	<b>23</b>		
6.1 Discharge Chute .....	23		
6.2 Discharge Chute Deflector.....	23		
6.3 Rotor Lock .....	24		
<b>7. Operating Instructions .....</b>	<b>25</b>		
7.1 Operating Safety Rules.....	25		
7.2 Machine Setup.....	26		
7.3 Adjust Ski Height .....	26		
7.4 Machine Break-In.....	27		
7.5 Pre-Operation Checks .....	27		
7.6 Starting Procedure.....	27		
7.7 Stopping.....	27		
7.8 Stopping in an Emergency.....	27		
7.9 Chipping Operation.....	28		
7.10 Unplugging the Chipper .....	28		
7.11 Transporting.....	30		
7.12 Storage .....	31		

## 1.2 Delivery Inspection Report

### Wallenstein BXS Series Roller Feed Chipper

To activate warranty, register your product at [WallensteinEquipment.com](http://WallensteinEquipment.com).

This form must be filled out by the dealer and signed by the dealer and customer at the time of delivery.

The product manuals have been received by me and I have been thoroughly instructed as to care, adjustments, safe operation, and applicable warranty policy.

I have thoroughly instructed the buyer on the equipment care, adjustments, safe operation and applicable warranty policy and reviewed the manuals.

Customer

Dealer

Address

Address

City, State/Province, ZIP/Postal Code

City, State/Province, ZIP/Postal Code

(        )  
Phone Number

(        )  
Phone Number

Contact Name

Model

Serial Number

Delivery date

### Dealer Inspection Checklist

- \_\_\_\_\_ Rotor turns freely and the blade clearance is correct.
- \_\_\_\_\_ All cutting edges are sharp and in good condition.
- \_\_\_\_\_ Discharge chute and deflector move freely.
- \_\_\_\_\_ Lock pins align and move freely.
- \_\_\_\_\_ All fasteners are tightened to the correct torque.
- \_\_\_\_\_ All grease points are lubricated.
- \_\_\_\_\_ Purchased accessories are included, if applicable.
- \_\_\_\_\_ Operator's Manual is in the storage tube.

### Safety Checks

- \_\_\_\_\_ All safety sign decals are applied and legible.
- \_\_\_\_\_ All guards, shields, and covers are installed and secure.
- \_\_\_\_\_ A retainer is installed through each hitch point.
- \_\_\_\_\_ SMV sign is installed.
- \_\_\_\_\_ Operating and safety instructions were reviewed.

### 1.3 Serial Number Location

Always provide the serial number of your Wallenstein product when ordering parts or requesting service or other information.

The Serial Number Plate location is shown in the illustration. **Please record the product Model and Serial Number in the space provided below for easy reference.**

The BX52S is shown, however the serial plate location is the same for all BXS Series machines.

Record Product Information Here	
Model:	
Serial Number:	

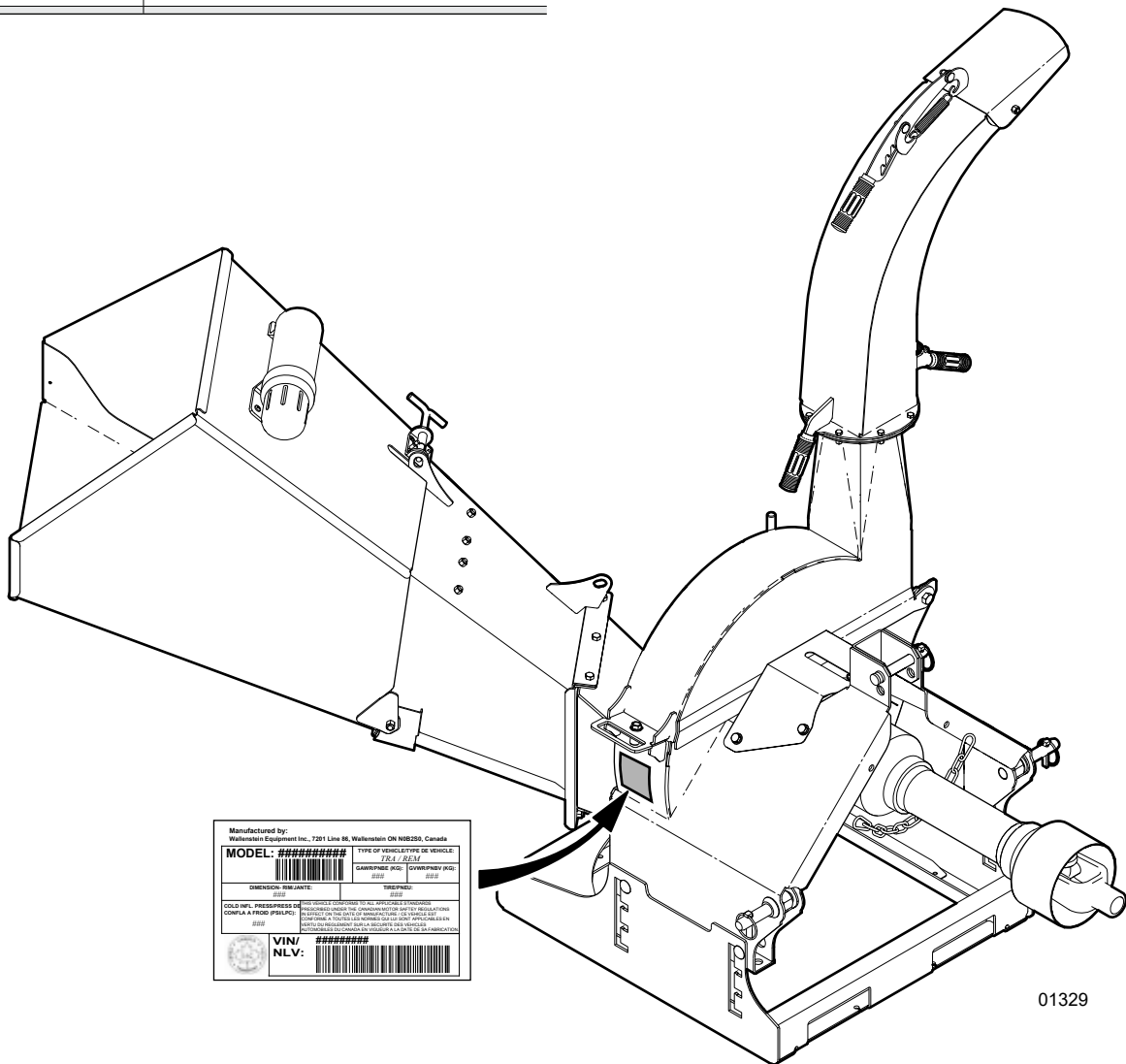
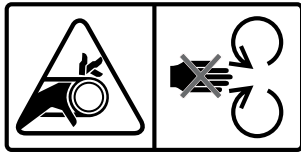

Fig. 1 – Serial Number Plate Location (Typical)

## 1.4 Types of Decals on the Machine

When getting familiar with the Wallenstein product, notice that there are numerous decals located on the machine. There are different types of decals for safety, information, and product identification. The following section explains what they are for and how to read them.

**Safety Sign Decals** have a yellow background and are generally two panel. They can be either vertical or horizontal.



**Safety Notice Decals** are pictorial with a blue background and generally rectangular with single or multiple symbols. This decal informs what Personal Protective Equipment is required for safe operation.



**Informative Decals** are generally pictorial with a white background and can vary in the number of panels. This type of decal provides additional information to the operator or explains the operation of a control.



**Product Decals** indicate machine model and serial number, and other important information.

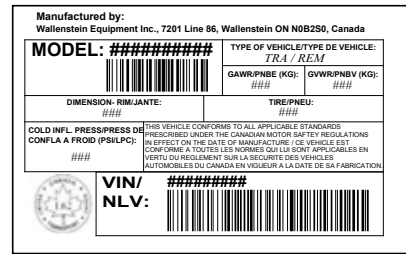

**Maintenance Decals** have a green background. The decal indicates a maintenance procedure and frequency interval.

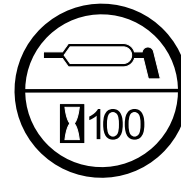

See the section on safety signs for safety decal definitions. For a complete illustration of decals and decal locations, download the parts manual for your model product at [WallensteinEquipment.com](http://WallensteinEquipment.com).

## 2. Safety

### 2.1 Safety Alert Symbol

This Safety Alert Symbol means:

**ATTENTION! BE ALERT!**

**YOUR SAFETY IS INVOLVED!**

The Safety Alert Symbol identifies important safety messages on the Wallenstein Wood Processor and in the manual.

When you see this symbol, be alert to the possibility of personal injury or death. Follow the instructions in the safety message.



### 2.2 Signal Words

The signal words **DANGER**, **WARNING** and **CAUTION** determine the seriousness level of the warning messages in this manual. The appropriate signal word for each message in this manual has been selected using the following guidelines:

#### **DANGER –**

Indicates an imminently hazardous situation that, if not avoided, **will** result in death or serious injury. This signal word is to be limited to the most extreme situations typically for machine components which, for functional purposes, cannot be guarded.

#### **WARNING –**

Indicates a potentially hazardous situation that, if not avoided, **could** result in death or serious injury, and includes hazards that are exposed when guards are removed. It may also be used to alert against unsafe practices.

#### **CAUTION –**

Indicates a potentially hazardous situation that, if not avoided, **may** result in minor or moderate injury. It may also be used to alert against unsafe practices.

**IMPORTANT** – To avoid confusing equipment protection with personal safety messages, a signal word **IMPORTANT** indicates a situation that if not avoided, could result in damage to the machine.

### 2.3 Why SAFETY is Important

- **Accidents disable and kill people.**
- **Accidents cost money.**
- **Accidents are preventable.**

**YOU** are responsible for the SAFE operation and maintenance of your Wallenstein product. **YOU** must make sure that anyone who is going to use, maintain or work around the machine is familiar with the operating and maintenance procedures and related **SAFETY** information contained in this manual. This manual alerts you to all good safety practices that should be used while using your Wallenstein equipment.

**YOU** are the key to safety. Good safety practices not only protect you but also the people around you. Make these practices a working part of your safety program. Be certain that **EVERYONE** using this equipment is familiar with the recommended operating and maintenance procedures and follows all the safety precautions.

**Do not risk injury or death by ignoring good safety practices.**

## 2.4 Safety Rules

- Provide operating instructions for this machine to all employees who are going to use it. An untrained operator is not qualified and can create the risk of possible serious injury or death.
- Read and follow ALL safety and operating instructions in this manual. The most important safety device on this equipment is a SAFE operator.
- Review safety related items annually with all personnel operating or performing maintenance.
- Always wear PPE when operating or servicing the machine. Hard hats, protective glasses, protective shoes, gloves, reflector type vests and ear protection are types of equipment that may be required.
- Avoid loose fitting clothing, loose or uncovered long hair, jewelry, and loose personal articles. These can get caught in moving parts. Jewelry may also ground a live circuit..
- Prolonged exposure to loud noise may cause permanent hearing loss! Power equipment with or without equipment attached can often be noisy enough to cause permanent, partial hearing loss.
- Wear hearing protection on a full-time basis if the noise in the operator's cab exceeds 80 dB. Noise over 85 dB on a long-term basis can cause severe hearing loss. Noise over 90 dB adjacent to the operator over a long-term basis may cause permanent, total hearing loss.



### **WARNING!**

**Hearing loss from loud noise (from engines, chain saws, radios, and other such sources close to the ear) is cumulative over a lifetime, without hope of natural recovery.**

- Keep a first-aid kit available for use should the need arise and know how to use it.
- Keep a fire extinguisher available for use should the need arise and know how to use it.



- **DO NOT** expect anyone to operate this machine unless they have read and understand all operation and safety instructions. An untrained operator is not qualified and can create the risk of possible serious injury or death. It is the machine owner's responsibility to make sure operators are properly trained.
- **DO NOT** allow riders during transport.
- **DO NOT** risk injury or death by ignoring good safety practices.

## 2.5 Equipment Safety Guidelines

Safety is one of the main concerns in designing and developing equipment. However, every year many accidents occur which could have been avoided by a few seconds of thought and a more careful approach to handling equipment.

Avoid hazards by observing the following precautions. Insist anyone working with you follow them as well.

- Keep all shields in place. If shield removal becomes necessary for repairs, replace the shield prior to use. In some cases, certain photographs or illustrations in this manual may show an assembly with a safety shield removed for clarity. However, equipment should never be used in this condition.
- Replace any safety sign or instruction sign that is not readable or is missing. **Location and explanation of safety signs starts on page 11.**
- Never consume alcohol or drugs while using this equipment. Alertness or coordination can be affected. Consult your doctor about using this machine while taking prescription medications.
- This equipment is dangerous to children and anyone unfamiliar with its operation. Do not allow persons to use or assemble this unit until they have read this manual and have developed a thorough understanding of the safety precautions and of how it works.
- The operator must be a responsible, properly trained and physically able person familiar with machinery and trained in this equipment's operations. If the elderly are assisting with work, their physical limitations need to be recognized and accommodated.
- Do not modify the equipment in any way. Unauthorized modification may result in serious injury or death and may impair the function and life of the equipment. Unapproved modifications void warranty.
- Never exceed the limits of a piece of machinery. If its ability to do a job, or to do so safely is in question – **DO NOT TRY IT.**



- An employer has the responsibility to train employees on equipment operation. When someone does not understand the basic operation of a piece of equipment, they can create dangerous situations very quickly. Operators must completely understand:
  - Safety section of this manual
  - Safety decals on the machine
  - Tractor operator's manual
- If this machine is loaned or rented, it is the owner's responsibility to make certain that prior to using, every operator is fully trained.
- Learn the controls and how to stop the tractor and machine quickly in an emergency.
- Clear working area of stones, branches or hidden obstacles that might be hooked or snagged, causing injury or damage.
- Determine where chips will be piled and ensure it does not interfere with safe operation of the machine
- Be aware of overhead hazards: branches, cables, electrical wires.
- Use this machine only in daylight or good artificial light.
- Be sure machine is properly mounted, adjusted and in good operating condition.
- Perform the **Pre-operation Checks** before starting work (see *Pre-Operation Checks on page 27*).

## 2.6 Safe Condition

The term **Safe Condition** is referenced throughout this manual. What this means is setting the machine in a state that makes it safe to load, service, maintain, or prepare for storage.

**Complete the following to place the machine in a Safe Condition before performing any service, maintenance work, or storage preparation:**

### Safe Condition

1. Lower the chipper to the ground.
2. Disengage the PTO.
3. Set the parking brake and turn off the tractor engine.  
Remove the ignition key.
4. Make sure all components have stopped moving.
5. Block and chock the tractor wheels.
6. If required, set the rotor lock.



## 3. Safety Signs

### 3.1 Safety Sign Locations

The top (or left-hand) panel shows the safety alert (the potential hazard), and the bottom (or right-hand) panel shows the message (how to avoid the hazard).

Practicing good safety means becoming familiar with safety signs and warnings and being aware of the situations that require alertness.

**Think SAFETY! Work SAFELY!**

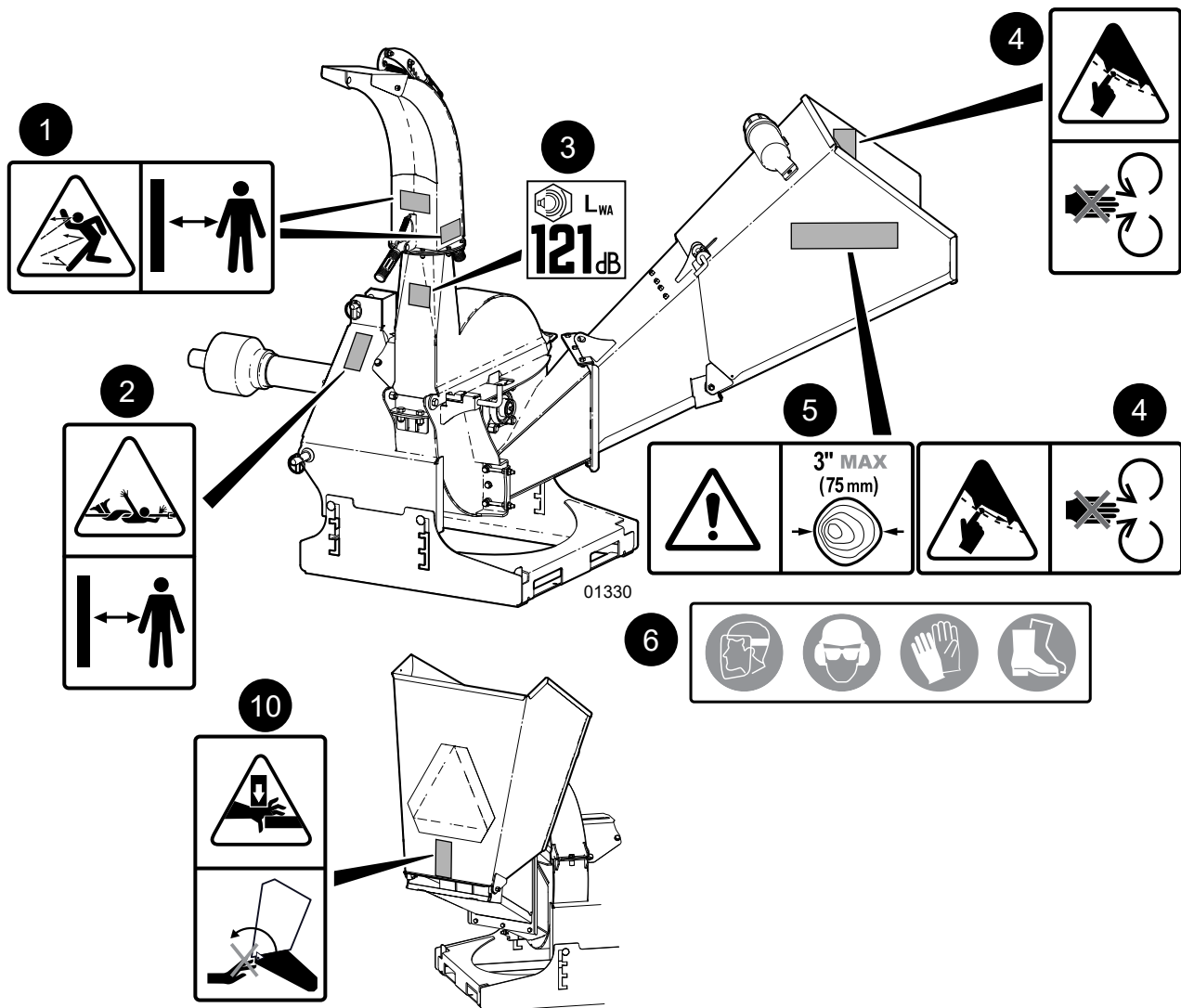
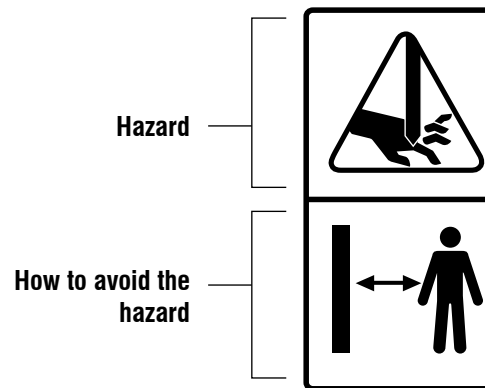

Fig. 2– Safety Sign Decal Locations

Safety

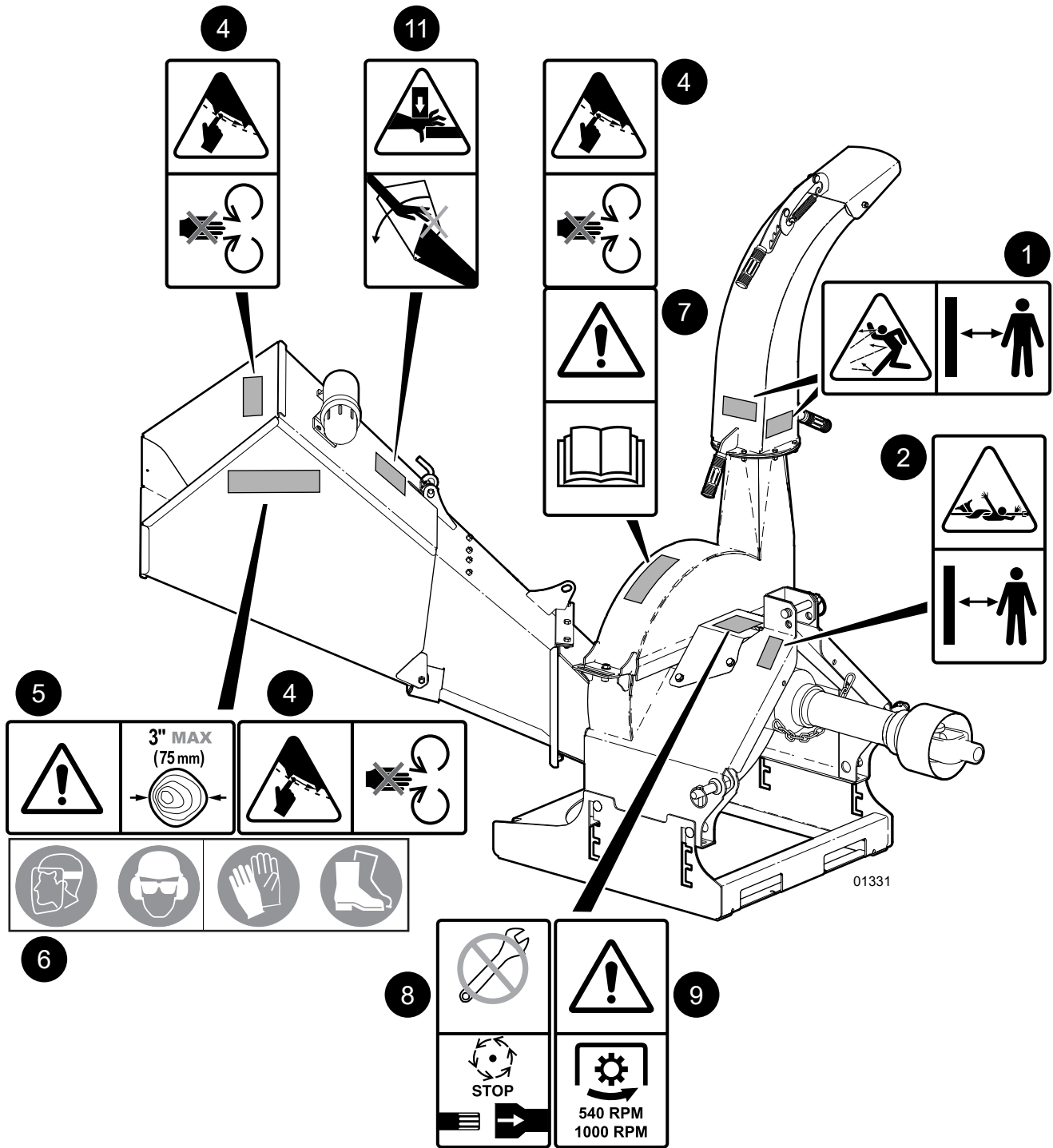

Fig. 3– Safety Sign Decal Locations

## 3.2 Safety Sign Explanations

**IMPORTANT!** If safety signs have been damaged, removed, become illegible or parts replaced without safety signs, new signs must be applied.

New safety signs are available from your authorized dealer.

### 1. WARNING!

#### Risk of injury from flying debris!

Stay clear of material discharge chute. Machine can expel wood chips fast enough to cause injury.

Do not point discharge at people, animals or buildings. Point chipper discharge away from work area and bystanders. Keep a safe distance from discharge.



### 2. WARNING!

#### Risk of entanglement in rotating drive line!

Stay clear of the PTO shaft when the chipper is operating. Do not operate chipper with PTO shaft cover removed. Keep hands, loose clothing, and long hair away from drive line while it is rotating.



### 3. CAUTION!

A noise declaration decal indicates the sound power (LWA) emitted by the machine when operating. For this chipper, it can be up to 121 decibels at close distances.

Always wear hearing protection when near the operating machine. Noise exposure over 85 dB on a long-term basis can cause severe hearing loss. Exposure over 90 dB over a long-term basis may cause permanent, total hearing loss.



### 4. WARNING!

#### Risk of fingers being severed or serious injury to hands in this area!

Keep hands and feet out of inlet and discharge openings while machine is operating.

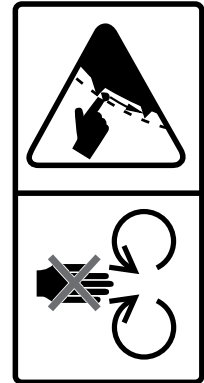

### 5. CAUTION!

#### Risk of personal injury!

Do not overload the chipper by placing material into the feed hopper larger than the size stated on the decal.

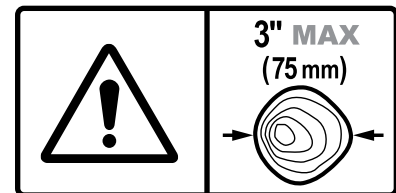

Machine damage could result.

### 6. CAUTION!

Always wear appropriate PPE during operation.

- A hard hat
- Hearing protection
- Protective glasses, goggles or face shield
- Protective shoes with slip resistant soles
- Heavy gloves



### 7. WARNING!

Refer to the operator's manual. Read ALL operating instructions in the manual. Learn the meaning of ALL safety signs on the machine before operating it!

The best safety feature is an informed operator.

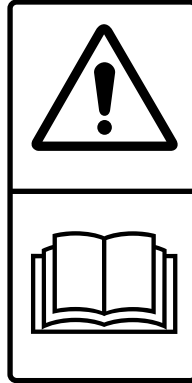

### 8. WARNING!

Risk of personal injury!

Stop the machine and disconnect the PTO shaft before performing any repair or maintenance procedure. Place the machine in a state that makes it safe to work on. See *Safe Condition* on page 7.

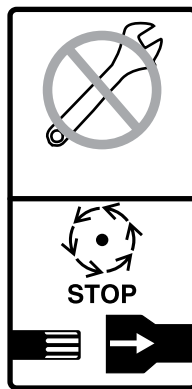

### 9. WARNING!

Risk of personal injury. Operate chipper at the correct PTO speed and direction.

Tractor PTO must operate at 540 or 1000 rpm, rotating in the direction of the arrow.

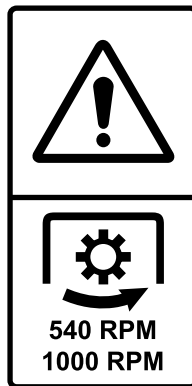

### 10. CAUTION!

Pinch point hazard.

On models where the hopper can be raised, be aware of pinch points. Keep hands clear to avoid injury.

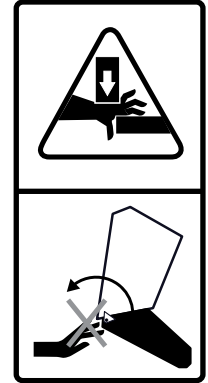

## 3.3 Replace Damaged Safety Signs

- Always replace safety signs that are missing or have become illegible. Replacement safety signs are available from your authorized distributor, dealer parts department, or the factory.
- Keep safety signs clean and legible at all times.
- Parts replaced that had a safety decal on them must also have the safety sign replaced.

### Procedure

Installation area must be clean and dry. Make sure the surface is free of grease or oil. Ambient temperature must be above 50 °F (10 °C).



*Determine exact position before removing the backing paper on the decal.*

1. Peel the decal off the backing sheet.
2. Align the decal with an edge on the machine if possible.
3. Starting on one edge, carefully press the center of the exposed sticky backing in place, smoothing it out as you work from one side to the other.
4. Use a squeegee, credit card or similar to smooth it out. Work from one end of the decal to the other end.

Small air pockets can be pierced with a pin and smoothed out using the piece of sign backing paper.

## 4. Familiarization

### 4.1 To the New Operator or Owner

Wallenstein BXS Series Wood Chippers are designed to chip and chop scrap lumber, small trees, brush, limbs and other wood debris. The chipped material is fine enough to be composted or used in a variety of ways.

**It is the responsibility of the owner or operator to read this manual and to train all other operators before they start working with the machine. Follow all safety instructions exactly. Safety is everyone's business. By following recommended procedures, a safe working environment is provided for the operator, bystanders and the area around the work site. Untrained operators are not qualified to use the machine.**

Many features incorporated into this machine are the result of suggestions made by customers like you. Read this manual carefully to learn how to use the chipper safely and how to set it to provide maximum field efficiency. By following these instructions in conjunction with a good maintenance program, your BX-S Wood Chipper will provide many years of trouble-free service.

**IMPORTANT! Make sure all operators understand how to place the machine in a Safe Condition before working with this machine. See page 7.**

### 4.2 Operator Orientation

**IMPORTANT! The directions for left-hand, right-hand, backward and forward mentioned throughout this manual are determined when sitting in the tractor seat, facing the direction of forward travel.**

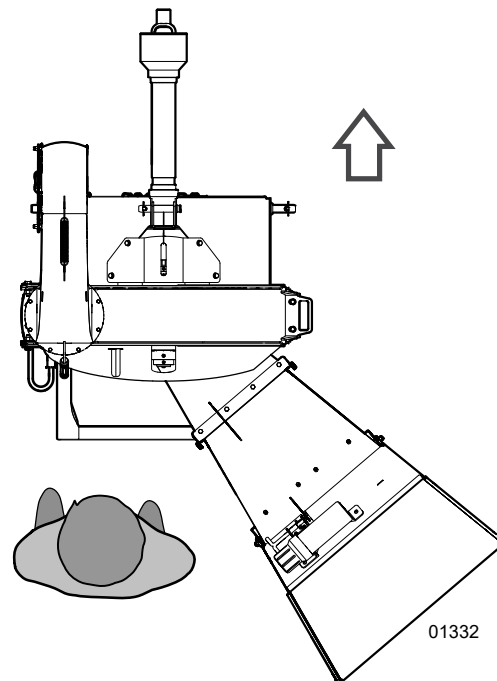

**Fig. 4**—Direction of forward travel





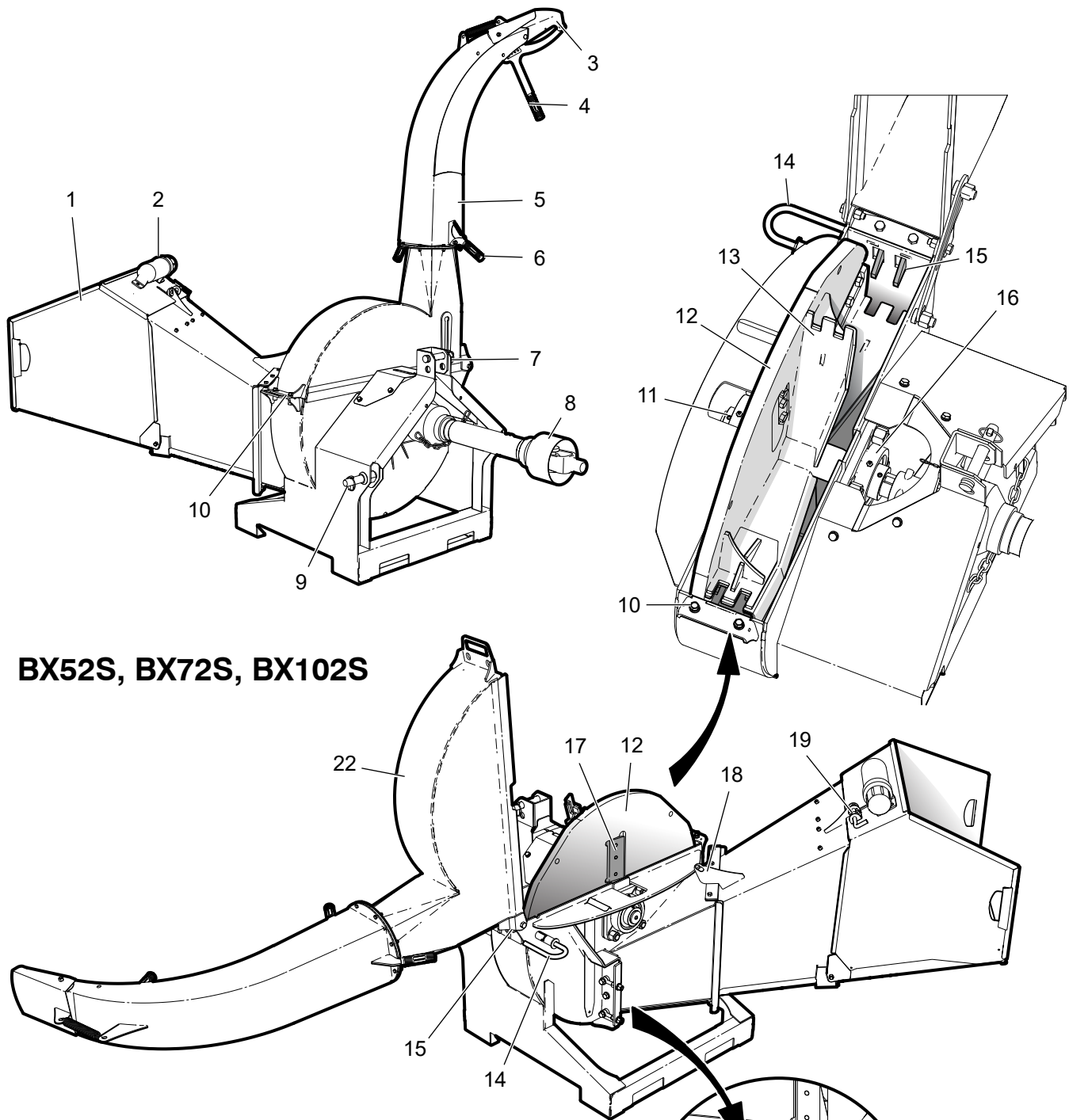

**BX52S, BX72S, BX102S**

**Fig. 6**—BX52S, BX72S, BX102S Machine Components

- |                                   |                             |
|-----------------------------------|-----------------------------|
| 1. Feed Hopper                    | 12. Rotor                   |
| 2. Operator's Manual Storage Tube | 13. Rotor Paddle            |
| 3. Hood Deflector                 | 14. Rotor Lock              |
| 4. Deflector Adjuster             | 15. Twig Breaker            |
| 5. Discharge Chute                | 16. Front Rotor Bearing     |
| 6. Discharge Chute Latch Handle   | 17. Rotor Blade             |
| 7. Top Link Pin                   | 18. Feed Hopper Latch Point |
| 8. PTO Shaft                      | 19. Feed Hopper Latch       |
| 9. Lower Link Pin                 | 20. Ledger Knife            |
| 10. Upper Rotor Housing Fastener  | 21. Ledger Knife Gauge      |
| 11. Rear Rotor Bearing            | 22. Upper Rotor Hood        |

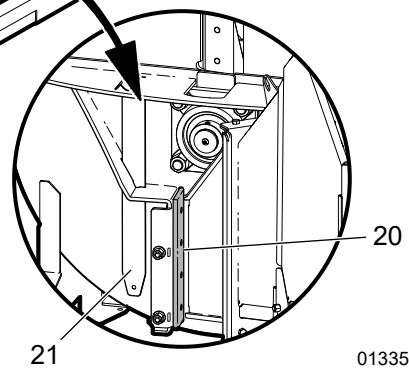

01335

## 5. Attach to a Tractor



Make sure the telescoping portion of the PTO shaft is greased and free of dirt.



The BX36S and BX52S lower ski is adjustable. Ski adjustment may be required to help make the PTO connection as level as possible. See *Machine Setup* on page 26.

### 5.1 Connect 3-point Hitch

#### **! WARNING!**

Never let anyone stand between the tractor and the implement during hitching. Too fast of an approach or the operator's foot slipping from the clutch can lead to injury or fatality to the person standing nearby.

W048

**IMPORTANT!** Removing the drawbar may be required for clearance.

For maximum PTO shaft life and safety, the PTO shaft should be as level as possible when the chipper is in the working position. See *Install PTO Shaft* on page 22.

- The BX36S, BX52S and BX72S are Category I, 3-point hitch, and Quick Hitch and iMatch™ compatible.
- BX102S is Category II, 3-point hitch only, and is also Quick Hitch and iMatch™ compatible.

Make sure there is enough room and clearance to safely reverse to the chipper.

#### Procedure

1. On the tractor, place the 3-point hitch lift arms in their full sway position, then reverse the tractor up to the chipper. The tractor needs to be exactly in-line with the mounting points of the chipper otherwise attaching the 3-point hitch may require moving the implement from side to side.
2. When reversing, lower/raise the lift arms so that they are level with the lower attachment points on the chipper.

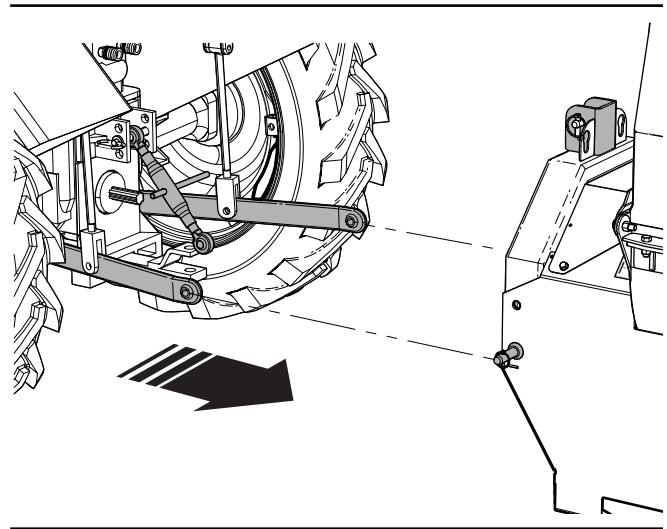

Fig. 7 – Back up in line with the chipper

3. Back up slowly and align the balls in the lift arms to the pins on the chipper.
4. Apply the tractor park brake.
5. Starting on one side, push the floating ball on the tractor's lift arms over the lower attachment pin on the chipper.
6. Do the other side in the same manner, keeping the lift arms even. Insert lynch pins on both sides to secure the chipper to the tractor.
7. Attach the tractor top link to the upper attachment point on the chipper. Insert the pin and lynch pin.
8. As with any implement, the turnbuckle on the top link may need to be adjusted to level the chipper. Raise the implement just off the ground to check. Adjust top link length as required.
9. If not already done, level the chipper from side to side using the lift arm jack-screw arm and the top link turnbuckle. The chipper frame should always be kept horizontal during operation.

## 5.2 Size PTO Shaft Length

**IMPORTANT!** The PTO shaft that came with your machine may need to be shortened. A longer shaft is supplied because tractor lift arms vary in length.

The PTO shaft must be free to telescope and not bottom out when going through its working range. It should never completely collapse in use. There should always be 2" (50 mm) of space for retract.

If the shaft bottoms out, the bearings on both ends can be overloaded and could fail causing damage or injury.

### **WARNING!**

Avoid the risk of personal injury or machine damage! Read the operator's manual before using this equipment. Carefully read all safety messages in the manual and follow all safety signs on the machine.

W081

### **CAUTION!**

Wear suitable eye protection when cutting steel tubes.

1. Remove the PTO shaft and mount the attachment on the tractor three-point hitch.
2. Start the tractor and raise the three-point hitch up off the ground until the machine's input shaft is level with the tractor PTO output shaft. **This is the shortest distance between the input and output shafts.**
3. Make sure tractor is shut off with parking brake applied.
4. Pull the PTO shaft apart and place one end on the tractor *output* spline. Place the other on the implement *input*.



Illustrations show a winch; however, the method is the same.

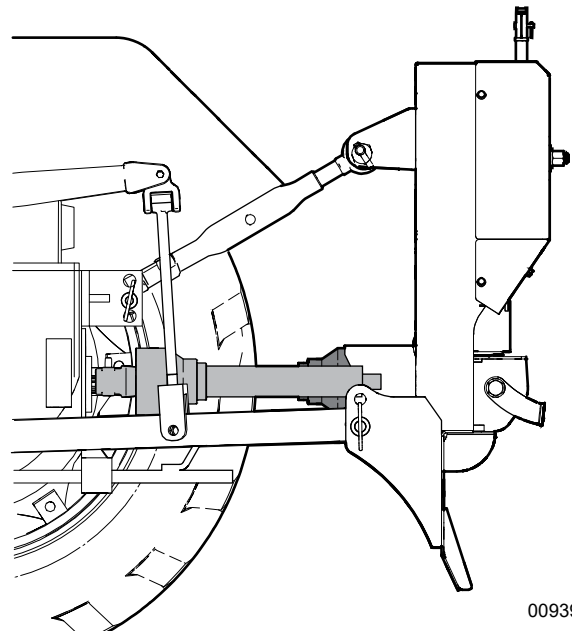

Fig. 8—Input shaft and output shaft

5. Lift the shaft ends up so that they are as parallel to each other as possible. Support them with blocking or tie them together. If the shafts are too long or there is not enough room to do this, see *Alternate Method* on page 21.

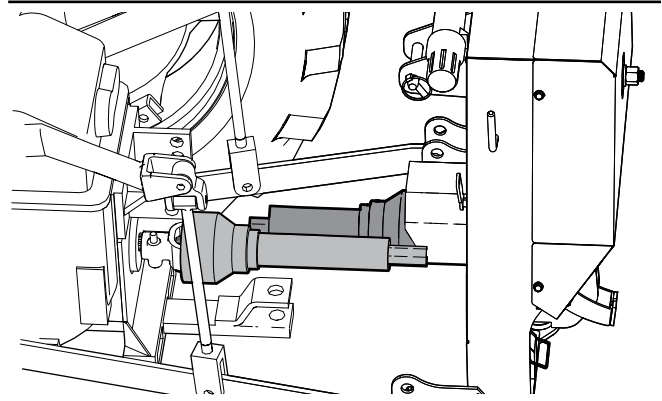

Fig. 9—Lift shaft ends up parallel

6. Using a straight edge, transfer a mark from the end of one tube section to the other section as shown.

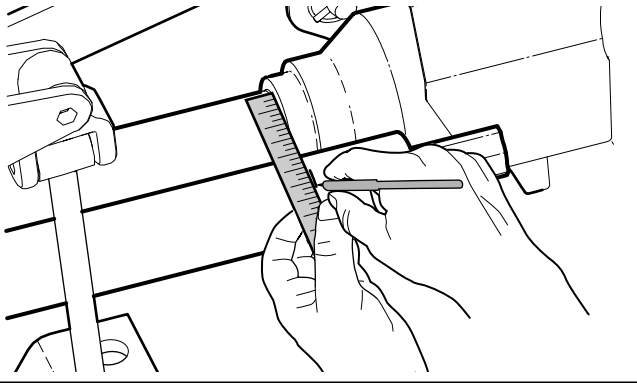

Fig. 10 – Transferring the mark

7. Add 2 inches (50 mm) to that measurement and place a second mark on the outer plastic tube. This is where the plastic shielding needs to be cut off.

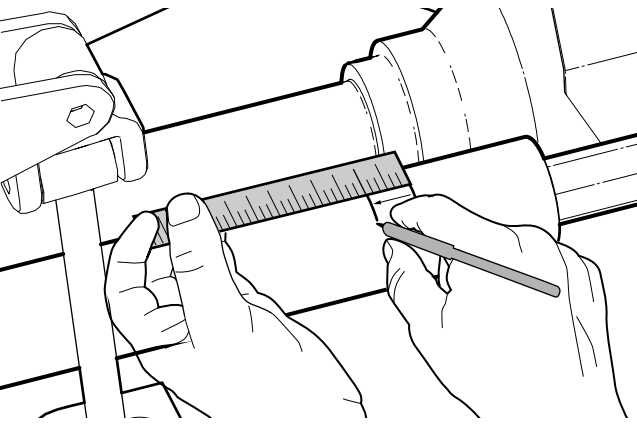

Fig. 11 – Place mark to cut plastic tube

8. Cut the plastic tube off at the mark, leaving the steel shaft inside.

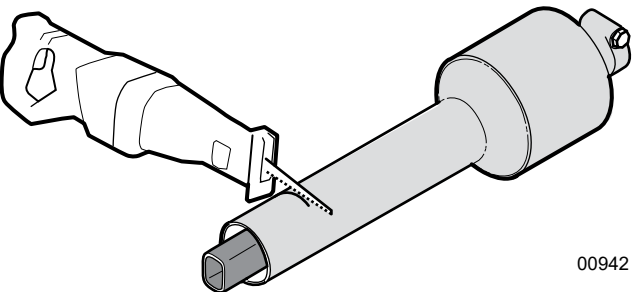

Fig. 12 – Cut plastic tube at the mark

9. Using the cut-off length of plastic tube as a guide, mark the steel tube. Align the end of the plastic tube with the end of the steel shaft.

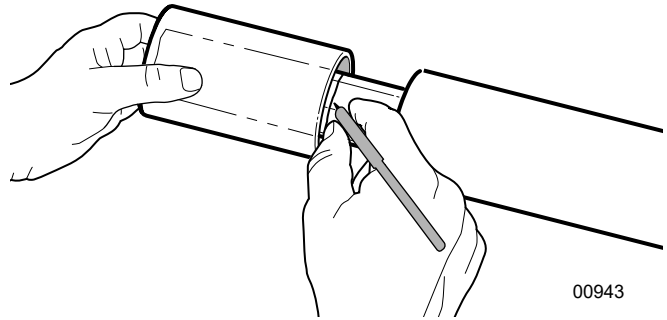

Fig. 13 – Marking steel tube.

10. Cut the steel tube off at the mark.  
11. Using the cut-off length of plastic tube to mark the remaining cuts, repeat this process for **BOTH** PTO shaft halves.



*Place the end of the steel shaft to be cut off in a vice so it is easier to control your cut.*

12. Remove the burrs from the edges of the steel shaft that were cut. Clean the steel shaft halves.  
13. Grease the inner tube so the tube halves slide together easier.

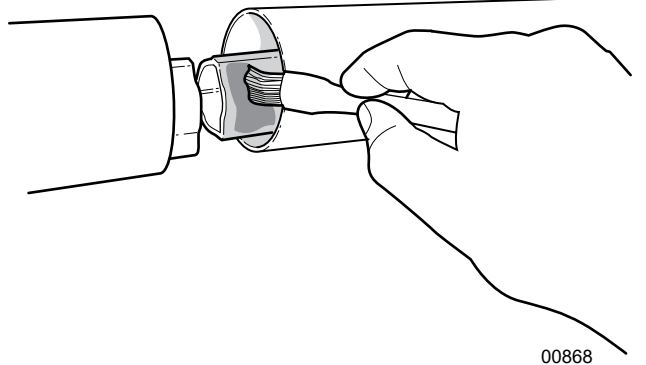

Fig. 14 – Grease the inner tube

14. Assemble the two halves of the PTO shaft.

**IMPORTANT!** Using a driveshaft not supplied with your machine may result in being assembled out of phase (universal joint yokes are not aligned with each other). Make sure driveshaft is assembled with u-joints in phase otherwise unbalances cause wear and eventually lead to failure.

- Make sure the shaft can telescope freely before installing. If it does not, separate the two parts and inspect for burrs or cuttings on the shaft ends.

**IMPORTANT!** The two PTO shaft halves should overlap inside at least 6" (150 mm).

### 5.2.1 Alternate Method

This method can be used if the two ends of the PTO shaft cannot be put close enough together to measure.

- Install the attachment on the tractor. Lift the attachment up so that the tractor output is level with implement input shaft.
- Take the PTO shaft that came with your machine, fully collapse it, and measure the distance between the locking yokes. Call this measurement **A**.

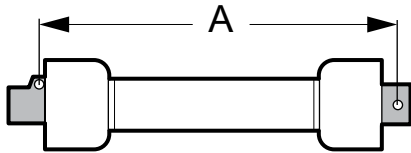

00586

Fig. 15—Measurement A

- Measure the distance between the grooves for the locking collars on each input. Subtract 2 inches (50 mm) from this measurement. Call this measurement **B**.

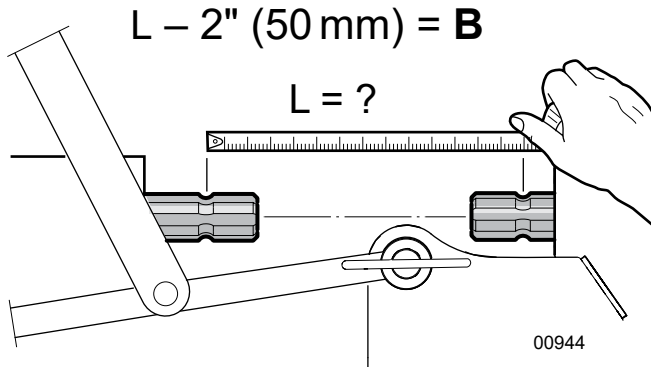

00944

Fig. 16—Measurement B

- If the collapsed length **A** is longer than measurement **B** from Step 3, the PTO shaft must be shortened.
- Subtract **B** from the uncut PTO shaft measurement **A**. ( $A - B$ )

The result is how much **BOTH** halves of the PTO shaft need to be shortened. Call this value **C**.

$$A - B = C$$

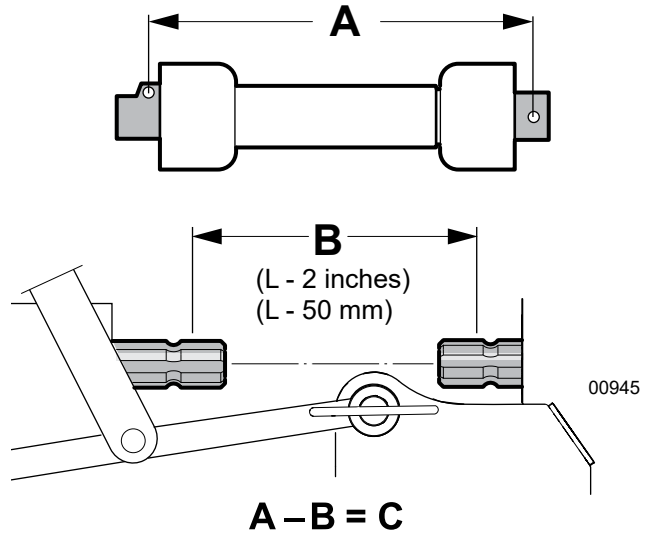

00945

Fig. 17—Value C = Cut Length

- Pull the PTO shaft apart, and then measure and cut the length **C** from both the outer plastic covers and the inner metal tubes.



Use the cut off piece of outer shielding to mark the inner tube. Leave the steel center tubes longer than the plastic outer tubes, otherwise they can be harder to put back together.

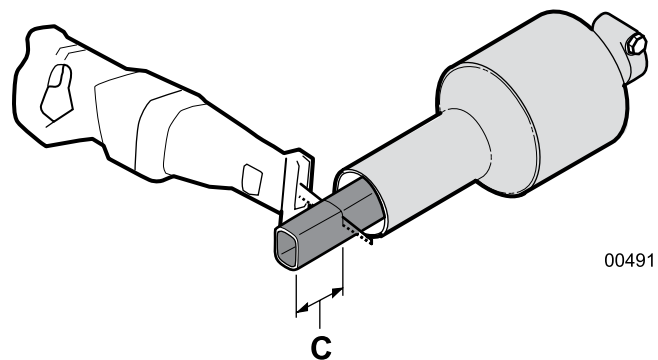

00491

Fig. 18—Cut off the Length C from both PTO Shaft halves

### 5.3 Install PTO Shaft

The implement must be mounted to the tractor, and fully lowered to the ground. Make sure tractor is shut off with parking brake applied.

Check to make sure the shielding on the PTO shaft is in good condition and able to turn freely, independent of the PTO shaft.

Make sure the PTO yoke ends are clean. Adding a small amount of lubricant on the splines can help them slide on.



A decal on the shielding indicates the tractor-end of the driveshaft.

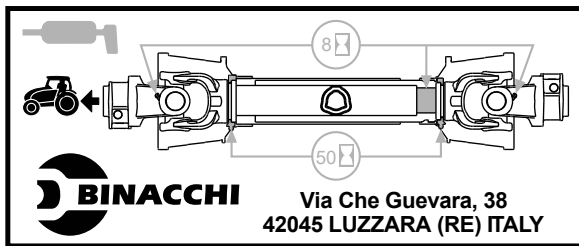

01655

1. Install the PTO shaft on the implement. Press the locking pin button and push the shaft end onto the input PTO. Connect the safety chain to the implement so that the shielding does not turn during operation.

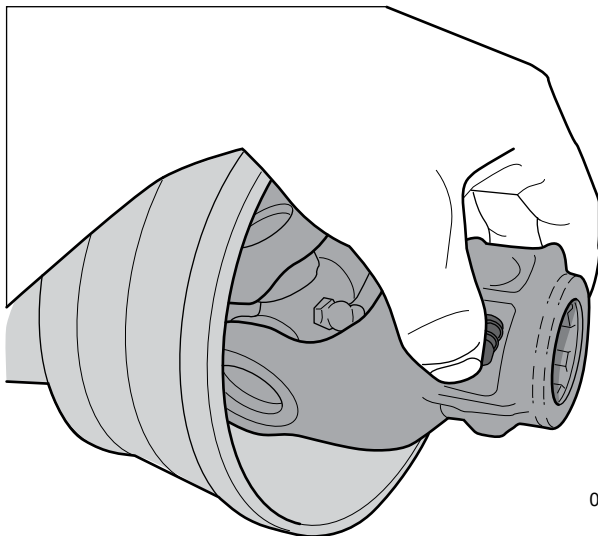

00866

Fig. 19—Locking Pin Button

2. Slide out the end of the PTO shaft up to the tractor output PTO, aligning the two shaft splines. Press the locking pin button and push the shaft end onto output PTO.
3. Once started, slide the shaft all the way on. You might hear a click and your button should retract to the original position.

4. To check that the shaft lock is fully seated, pull back on the shaft with your hands off the button.
5. Start the tractor and raise / lower the attachment to check clearances. A correctly sized shaft should never bottom out or come apart.

**IMPORTANT! Check driveshaft alignment. During operation, the working angle should not be greater than 15° between the tractor and the implement. Misalignment can cause premature wear and eventually failure.**

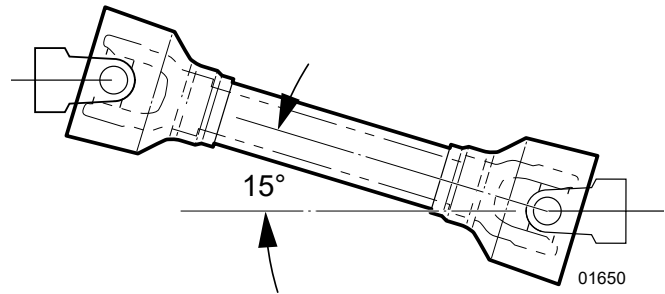
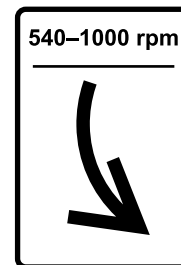

Fig. 20—Driveshaft Alignment

6. Check the rotation direction. A decal on the machine indicates correct rotation.



## 6. Controls

### 6.1 Discharge Chute

The discharge chute can rotate 360° and be locked at various lock points around the rotation. The BX36S model has one latch handle. The other models have a latch handle and an opposing grip handle.

#### BX36S

- Push the latch handle down to disengage the chute lock. Rotate the chute to the desired position, then release the handle. Make sure it locks at nearest lock point.

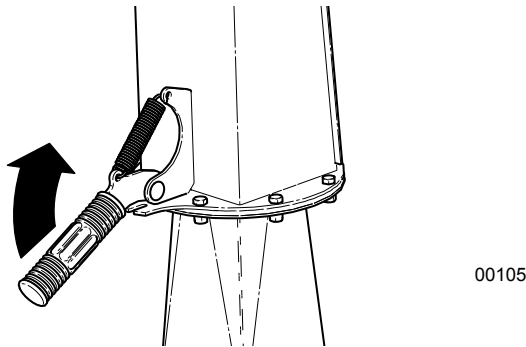

Fig. 21 – BX36S

#### BX52S, BX72S, and BX102S

- Push latch handle down to disengage the chute lock. Rotate the chute using the latch and grip handles to the desired position. Release the handles and make sure it locks at nearest lock point.

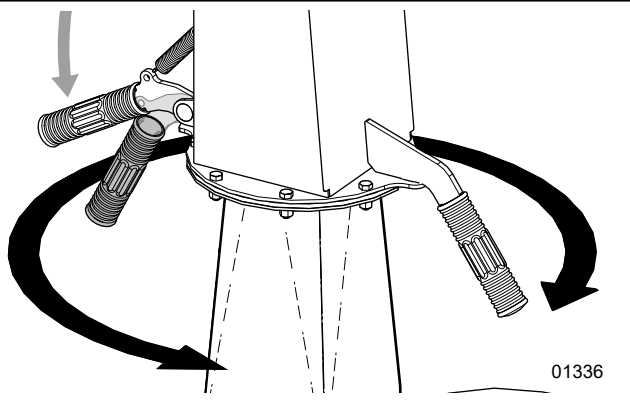

Fig. 22 – BX52S, BX72S, BX102S

### 6.2 Discharge Chute Deflector

The chute has a hood deflector on the end of it to direct wood chips.

#### BX36S

- The deflector has hand knobs on each side. Loosen the hand knobs, reposition the deflector, then tighten the hand knobs.

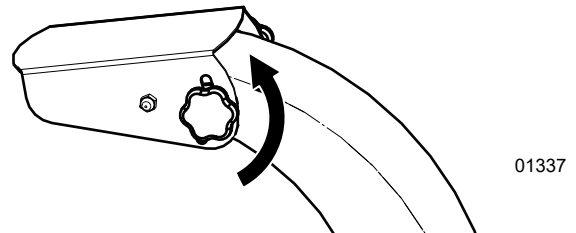

Fig. 23 – BX36S

#### BX52S, BX72S, BX102S

- The chute has a spring-tensioned hood deflector on the end of the chute held in position by a slotted position handle.
- Lift the handle slightly to clear the cogs, reposition the deflector, then lower it to lock it into one of the slots.

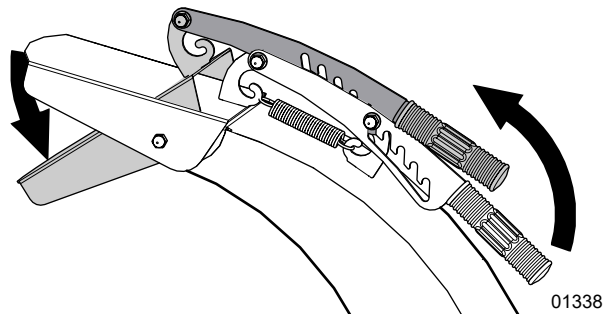

Fig. 24 – BX52S

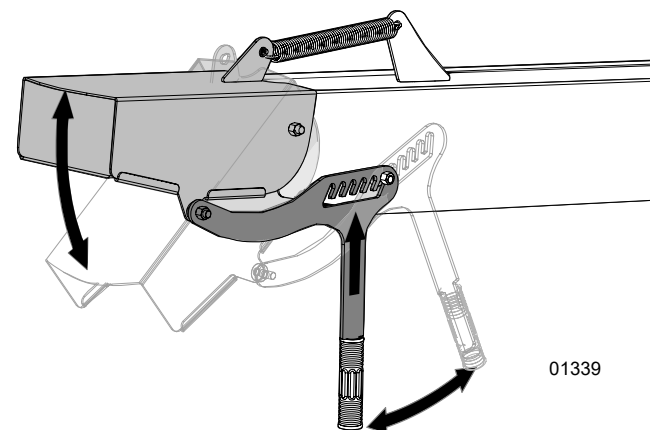

Fig. 25 – BX72S, BX102S

## 6.3 Rotor Lock

The Rotor Lock is used to secure the rotor from moving while the upper rotor housing is open. It can only be engaged when the rotor housing is open. The spring pin cannot be engaged when the rotor housing is closed. This prevents unintended use while in operation.

**The rotor lock pin should be used anytime the rotor housing is open to prevent potential injury.**

### 6.3.1 Set Rotor Lock

- First, place the chipper in a **Safe Condition**. See page 7.
- Open the upper housing.
- Turn the lock handle up so that the spring pulls the handle pin into the groove.

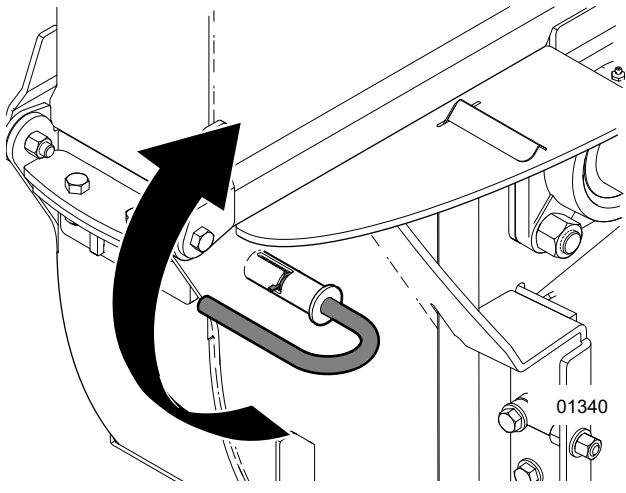

**Fig. 26**—Rotor Unlocked Position

- Allow the spring to pull the lock handle up against the rotor.
- Turn the rotor slowly by hand until the lock handle slips into one of the holes in the rotor.
- Verify that the pin is fully inserted, and the rotor does not turn.

### CAUTION!

**Avoid reaching into rotor compartment. Rotor chipper blades are very sharp. If reaching inside is necessary, use extreme care.**

W003

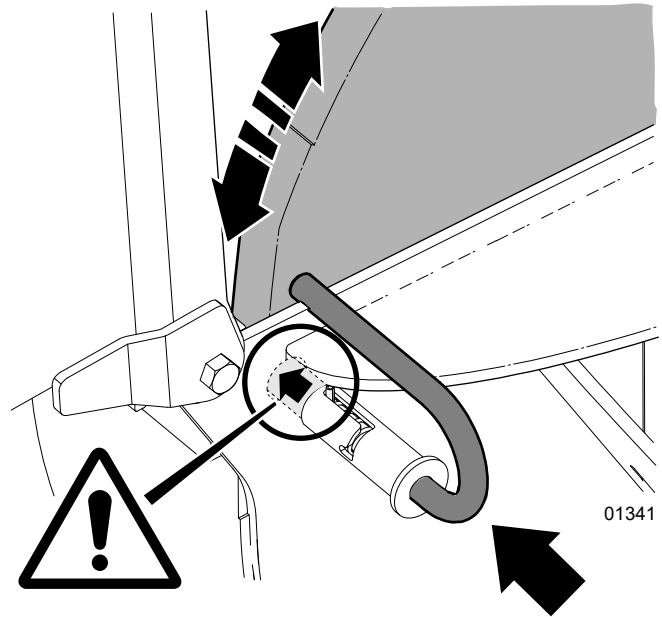

**Fig. 27**—Rotor Locked Position

- Reverse the above procedure to unlock the rotor.



*The upper housing cannot be closed with rotor lock engaged.*



## 7. Operating Instructions

### **WARNING!**

Never reach into the feed hopper. Doing so risks hands getting caught. Use a stick or branch to push in any material that does not move on its own.

If jammed, stop the engine, wait for the rotor to stop, then clear the jam.

W004

### **CAUTION!**



Hearing loss hazard. Prolonged exposure to loud noise may cause permanent hearing loss. Use suitable protection while operating the machine.

W016

**IMPORTANT!** Do not put metal objects, bottles, cans, rocks, glass or other foreign material into wood chipper. If such items happen to get into the chipper, stop machine and turn engine off. Wait for all moving parts to stop before removing material. Inspect machine for damaged or loose parts before resuming work.

**IMPORTANT!** Do not use PTO Cruise Control with this wood chipper. The chipper rotor slows and speeds up as material is fed in. Cruise control then attempts to adjust to changing flywheel speeds. These fluctuations in engine speed and torque can result in component failure.

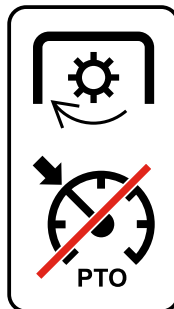

The operator has the responsibility of being familiar with and following all operating and safety procedures.

Although this machine is easy to use, each operator should review this section to become familiar with the detailed safety and operating procedures.

### 7.1 Operating Safety Rules

- Avoid loose fitting clothing, loose or uncovered long hair, jewelry, and loose personal articles. These can get caught in moving parts.

- Do not reach into rotor or feed hopper openings when the machine is running. Install and secure access covers before starting engine.
- Do not move or transport chipper when the rotor is turning.
- Keep the working area clean and free of debris to prevent tripping. Operate only on level ground.
- Do not point discharge at people, animals or buildings. Rotor can expel wood chips fast enough to cause injury.
- Be aware of the size and shape of the material. Crotchety branches and logs can move in unpredictable ways as they pass through the feed rollers and could cause injuries. Large curved pieces should be cut to smaller straighter sections.
- Do not work alone, it is safer to work in pairs in case an emergency arises.
- Never stand, sit, or climb onto any part of the chipper while it is running.
- Place chipper in a Safe Condition before servicing, adjusting, repairing, or unplugging.
- Always use the rotor lock to immobilize the rotor when attempting to clear a clog or changing chipper blades. See *page 24*.
- Do not run machine inside a closed building to prevent asphyxiation from engine exhaust.

### **CAUTION!**

Do not risk injury by working in an unsafe situation. Take steps to make the machine safe to work on before performing any maintenance or service procedure.

Follow steps listed to put the machine in a Safe Condition.

W049

#### Safe Condition

1. Lower the chipper to the ground.
2. Disengage the PTO.
3. Set the parking brake and turn off the tractor engine. Remove the ignition key.
4. Make sure all components have stopped moving.
5. Block and chock the tractor wheels.
6. If required, set the rotor lock.

## 7.2 Machine Setup

### Make sure:

- The chipper is properly attached to the tractor 3-point hitch.
- Correct length PTO shaft is installed.

### CAUTION!

Park the machine so prevailing winds blow exhaust gases / fumes away from the operator.

W006

1. Position the tractor and wood chipper at the work site in a clear, level work area.
2. Set the tractor brake and block / chock the wheels.
3. Make sure the area is clear of bystanders, especially children.
4. Lower the chipper to the ground. Make sure the machine is resting on the ground and is level and stable.
5. Lower the feed hopper (all models except the BX36S). While holding the feed hopper, release the latch pin from the tab, and carefully lower the hopper. Engage the spring loaded latch pin to secure the hopper.

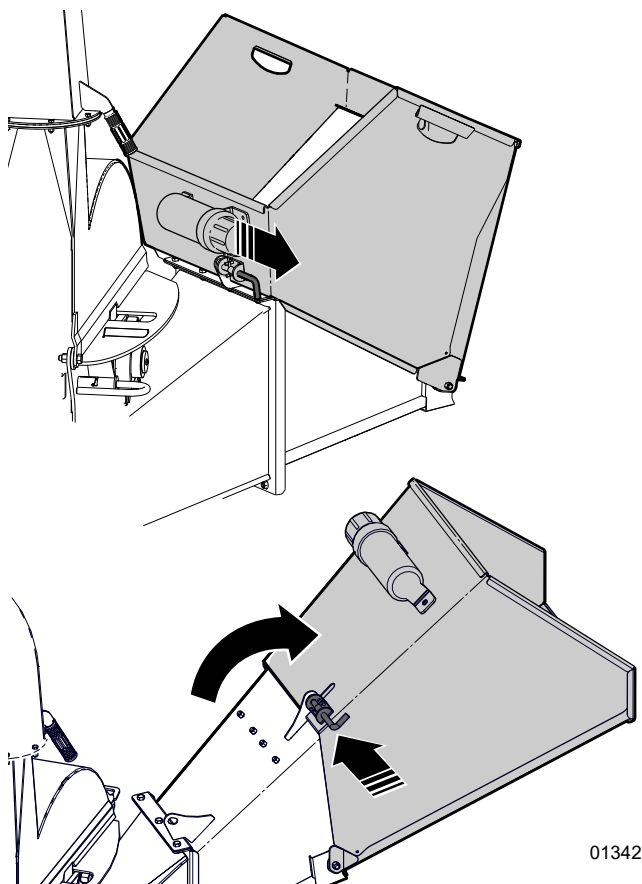

01342

Fig. 28—BX52S, BX72S, BX102S

6. Turn the discharge chute to the desired position and adjust the deflector as required.

**IMPORTANT!** The chipper must be resting on the ground during operation. Using the chipper with it raised up off the ground is dangerous and will result in damage to the machine.

## 7.3 Adjust Ski Height

### B36S, BX52S models

The ski can be adjusted up to 6" (15 cm) if required, to help align the PTO when attaching the chipper to the tractor. The PTO shaft should be as level as possible when the chipper is sitting on the ground (the working position).

**IMPORTANT!** Do not adjust ski height based on operator comfort. The PTO can be damaged if the working angle is too great.

#### To adjust the ski:

1. With the chipper connected to the tractor, raise it up off the ground.
2. Loosen the four hex nuts on the ski bolts.
3. Adjust the ski to the best height for PTO angle, then tighten the hex nuts.

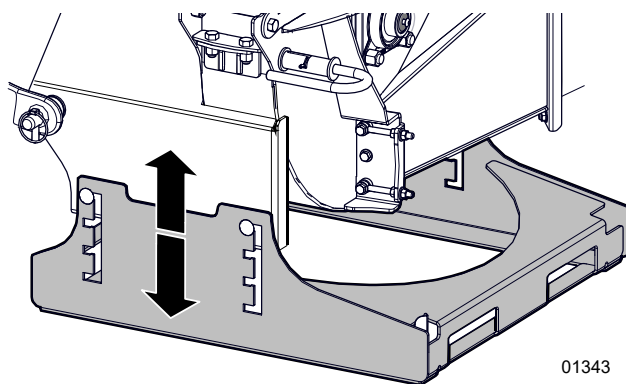

01343

Fig. 29—Adjust ski height

## 7.4 Machine Break-In

Although there are no operational restrictions on the Wood Chipper when used for the first time, it is recommended that the following mechanical items be checked.

Place the machine in the **Safe Condition** before checking any components. (See *Safe Condition on page 7*).

### After operating for 1 hour:

- Check that all fasteners and hardware are tight.
- Check condition of rotor bearings.
- Check the condition and clearance of the twig-breaker, rotor and stationary blades. Adjust or replace as required.
- Check for entangled material. Remove all entangled material before resuming work.
- Lubricate rotor bearings with one pump from a hand-held grease gun per bearing.

### After operating for 10 hours:

- Repeat steps listed above.
- Go to the normal servicing and maintenance schedule as defined in the Maintenance Section.

## 7.5 Pre-Operation Checks

Before operating the Wood Chipper and each time thereafter, check the following items.

Item to Check	
Check that the machine has been lubricated as outlined in the Maintenance Section.	
Check the rotor housing and discharge chute. Remove any blockages, twine, wire or other material that has become entangled .	
Check the condition and clearance of the twig breaker, rotor and ledger blades. Adjust or replace as required.	
Check that rotor bearings turn freely. Replace if they do not.	
Check and ensure that all covers, guards, and shields are in place, secure, and functioning as designed.	
Check and tighten all fasteners. Make sure the equipment is in good condition.	

## 7.6 Starting Procedure

After following all operating safety and preparation procedures, consider the chipper ready to operate.

1. Make sure all the chipper access covers are secure.
2. Start tractor and engage PTO. Set tractor at half throttle. Make sure the rotor is up to speed before beginning.
3. Increase engine speed to 540 or 1,000 rpm.
4. Ensure machine is stable before proceeding with work.

## 7.7 Stopping



**Be aware. Rotor continues to turn for a few revolutions after the PTO is disengaged. Wait for all parts to stop moving before opening any machine access.**

W005

1. Stop feeding material into the hopper.
2. Slow engine speed.
3. Disengage PTO.
4. Stop engine, remove ignition key.

## 7.8 Stopping in an Emergency

If an emergency occurs:

- **Activate the emergency PTO shutoff on the tractor (if available) or disengage the PTO**
- **Shut off the engine**
- **Correct emergency situation before restarting engine and resuming work.**

## 7.9 Chipping Operation

### Chipper Capacity

Model	Material Size
BX36S	3.5" (9 cm)
BX52S	5" (13 cm)
BX72S	7" (18 cm)
BX102S	10" (25 cm)

- Before beginning, ensure the motor is warmed up and the rotor is up to speed.
- Delimb large branches and trees and feed them in one at a time.
- Stand to the side of the feed hopper and slowly slide material in. Do not force it.

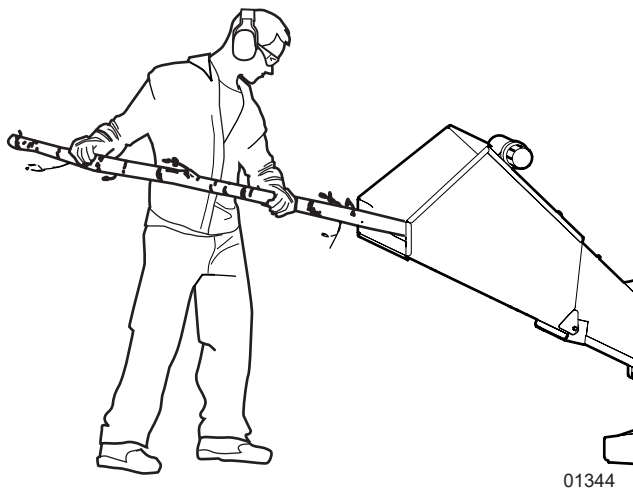

**Fig. 30**—Stand to Side of Feed Hopper

- Be aware of the size and shape of the material. Knotty, curved branches and logs can move in unpredictable ways as they pass through the feed rollers. Large curved pieces should be cut to smaller straighter sections.
- Very small diameter branches / limbs can be held together in a bundle and feed in simultaneously.
- Place short branches on top of longer ones, to avoid reaching into the hopper.
- Make sure the wood chip pile is contained and does not affect the immediate work area.

### **! WARNING!**

**Never reach into the feed hopper. Doing so risks hands getting caught. Use a stick or branch to push in any material that does not move on its own.**

**If jammed, stop the engine, wait for the rotor to stop, then clear the jam.**

W004

## 7.10 Unplugging the Chipper

The wood chipper is designed to handle a wide range of material sizes without any problem. However, in the event material gets lodged in the chipper, follow this procedure to clear the blockage.

### **! CAUTION!**

**Be aware. Rotor continues to turn for a few revolutions after the PTO is disengaged. Wait for all parts to stop moving before opening any machine access.**

W005

**Shut down the tractor and place the chipper in a Safe Condition before proceeding further. See page 7.**

1. Pull any remaining material out of the feed hopper and discharge hood.
2. Use a stick to poke loose any material jammed into the discharge hood. Be sure all the material is out and nothing is jammed or wedged between the input opening and the rotor.
3. Check that everyone is clear of machine before restarting the machine.
4. Start the tractor and resume working.

**If the chipper is still plugged, the jammed material must be removed by hand using the following steps.**

5. Open the upper rotor housing and engage the rotor lock.

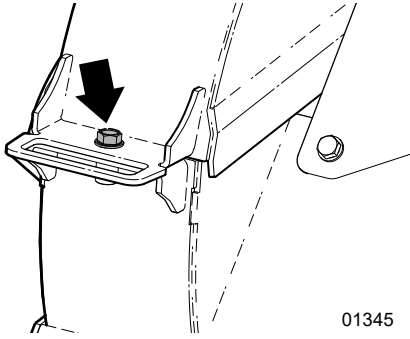

Fig. 31 – Rotor Housing Flange Bolt

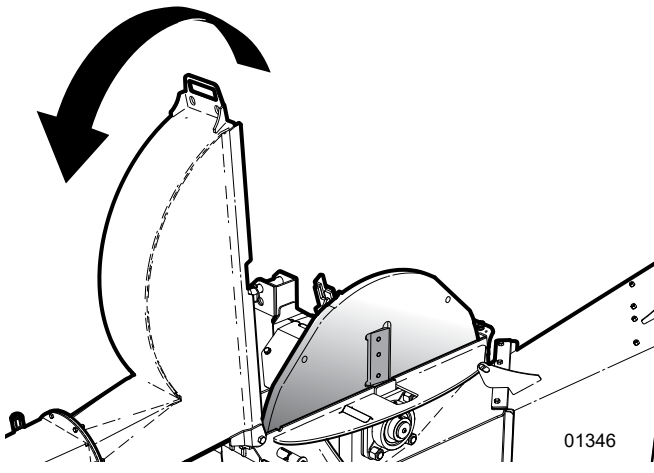

Fig. 32 – Open Upper Rotor Housing

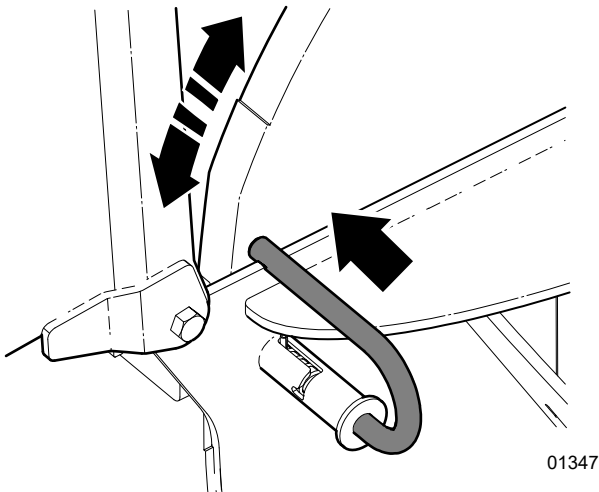

Fig. 33 – Engage Rotor Lock

## CAUTION!

Avoid reaching into rotor compartment. Rotor chipper blades are very sharp. If reaching inside is necessary, use extreme care.

W003

6. Remove jammed material from inside the rotor compartment.
7. Clean out the discharge chute.
8. Inspect the lower rotor housing and clean out any debris.
9. If required, rotate the rotor: disengage the rotor lock and **very carefully** and slowly turn the rotor by hand to be sure there is nothing jammed between the rotor and stationary blades. **Do not reach into the rotor housing while the rotor is moving or unlocked.**
10. Disengage the rotor lock to close the upper rotor housing. Fasten the rotor housing flange bolt..

## WARNING!

Machine shown with shields removed for illustrative purposes only. Never operate machine with shields removed.

W001

## 7.11 Transporting

- **Do not exceed a safe travel speed.**
- **Always follow and obey applicable highway rules and regulations.**
- **Be sure all lights, markers and SMV sign required by the traffic regulations are in place, clean and working.**
- **Check three-point hitch connections and ensure they are safely pinned with retainers.**
- **Never allow riders on the machine.**
- **Avoid rough terrain. Slow down when encountering rough conditions or cornering.**

### Prepare for Transport

1. Make sure all access covers are secured in place, and the rotor upper housing is bolted down.
2. Place the feed table in the stowed position.
3. Turn the discharge hood towards the tractor to reduce the width of the machine.
4. Clean all debris off the chipper. Falling debris could cause problems for other traffic.
5. Make sure the tractor is in safe working order.
6. Plan the route. Choose the most direct and safest path.

### Stow the Feed Hopper

(All models except the BX36S.) The feed chute folds up when not in use for transportation and storage.

1. Release the feed chute lock pin.
2. Grasp the front edge of the feed chute and fold it up to its vertical position.
3. Secure the feed table by engaging the latch pin into the pin tab.

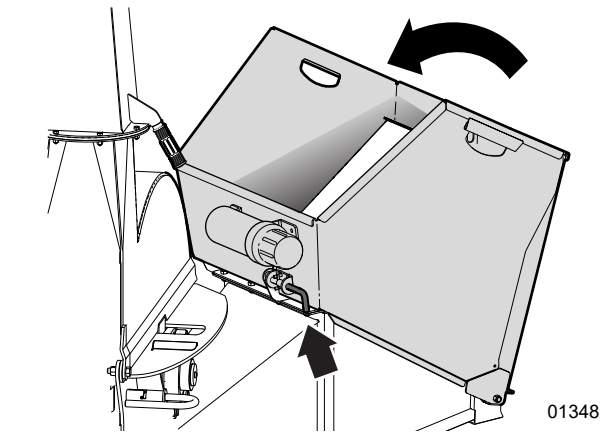

**Fig. 34**—Stowing the Feed Hopper

## 7.12 Storage

After the season's use or when the machine is not going to be used for a period, place the chipper in storage.

- Completely inspect all major systems.
- Replace or repair any worn or damaged components to prevent any unnecessary down time at the beginning of the next season.

**IMPORTANT!** If the chipper is equipped with the Power Pack option, refer to the engine owner's manual for storage preparation.

1. Remove all dirt, mud, and debris. Inspect all rotating parts for entangled material.
2. Wash off machine, then operate it for a few minutes to dry the inside the machine.
3. Lift the feed hopper up and lock it there (all models except BX36S).
4. Turn chute inward to reduce machine width.
5. Touch up all paint nicks and scratches to prevent rusting.
6. It is best to store the machine inside. If that is not possible, cover with a waterproof tarp.
7. Store in an area away from human activity.
8. Do not allow children to play around the stored unit.

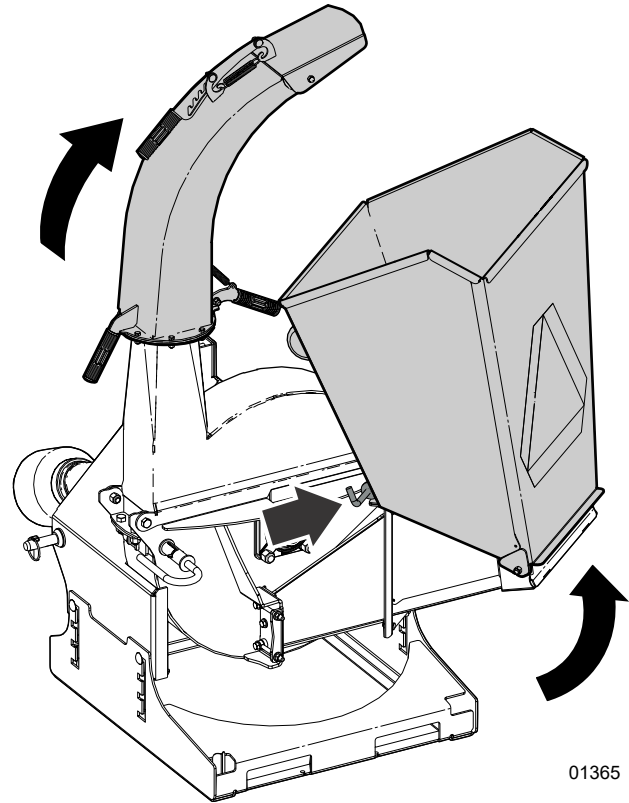

01365

Fig. 35—Feed hopper stored

## Removing from Storage

When removing this machine from storage, follow the Pre-operation Checks. (See page 27).



When lowering the feed hopper, be aware of the pinch point between the hopper and the sub chute.

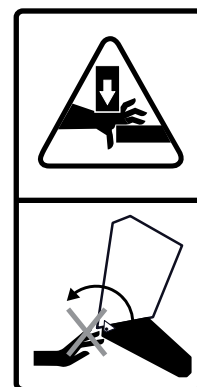

## 8. Service and Maintenance

- Follow good shop practices:
  - Keep service area clean and dry.
  - Be sure electrical outlets and tools are properly grounded.
  - Use adequate light for the job at hand.
- Never operate the tractor engine inside a closed building. The exhaust fumes may cause asphyxiation.
- Place machine in a Safe Condition before servicing or repairing. See *page 9*.
- Allow the machine to cool before performing maintenance. Components and oil may be hot enough to cause burn injury.
- Never work underneath equipment unless it is blocked securely.
- When performing any service or maintenance work always wear proper PPE for the job.
- Where replacement parts are necessary, genuine factory replacement parts must be used to restore equipment to original specifications. The manufacturer is not responsible for injuries or damages caused by use of unapproved parts or accessories.
- Inspect and tighten all bolts, nuts and screws. Check that all electrical and hydraulic connections are properly secured to ensure chipper is in a safe working condition.
- After completing a service procedure, make sure all covers and shields are reinstalled.
- When cleaning any parts, do not use gasoline or diesel fuel. Use a regular cleanser.
- Always use proper tools in good condition.

### WARNING!

**Risk of serious personal injury. Stop engine before performing ANY service or maintenance procedure. Reinstall all covers and shields removed before putting machine back into service.**

W033

### WARNING!

**Shut down the machine and allow it to cool before performing any service, maintenance, or inspection procedure. Engine components and oil may be hot enough to cause injury.**

**Make sure the machine is in a Safe Condition to work on. Review Maintenance Safety beforehand.**

W041

### Safe Condition

1. Lower the chipper to the ground.
2. Disengage the PTO.
3. Set the parking brake and turn off the tractor engine. Remove the ignition key.
4. Make sure all components have stopped moving.
5. Block and chock the tractor wheels.
6. If required, set the rotor lock..

## 8.1 Grease Type

Use an SAE multi-purpose high temperature grease with extreme pressure (EP) performance. Also acceptable is an SAE multipurpose lithium-based grease.



## 8.2 Maintenance Schedule

Perform maintenance procedures at time shown or hour interval, whichever comes first.

As required	
Remove entangled material from chipper.	
Lubricate hinges and pivot points.	
Every 8 hours or daily	
Grease PTO Shaft	See this page, and page 35
Perform Pre-operation check	See page 27
Every 50 hours or annually	
Check rotor blade sharpness	See page 36
Check ledger knife sharpness	See page 7
Check twig breaker	See page 35
Grease entire machine	See page 34
Every 100 hours or annually	
Wash and clean wood chipper. Remove entangled material, wood chips, small debris.	

## 8.3 Grease Points

**IMPORTANT! Use a hand-held grease gun for all greasing. Pump one shot of grease per fitting.**

- Wipe grease fitting with a clean cloth before greasing to avoid injecting dirt and grit.
- If fittings do not take grease, remove and clean them thoroughly. Replace grease fittings as necessary.

Location	Every 8 hours of operation
1	PTO Shaft Universal Joints
2	PTO Shaft Slip Joint

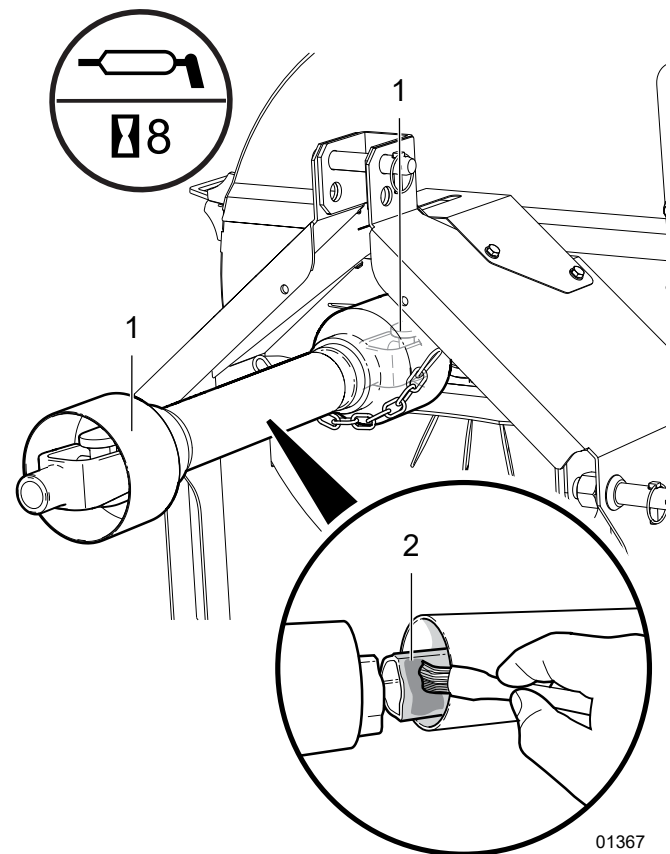
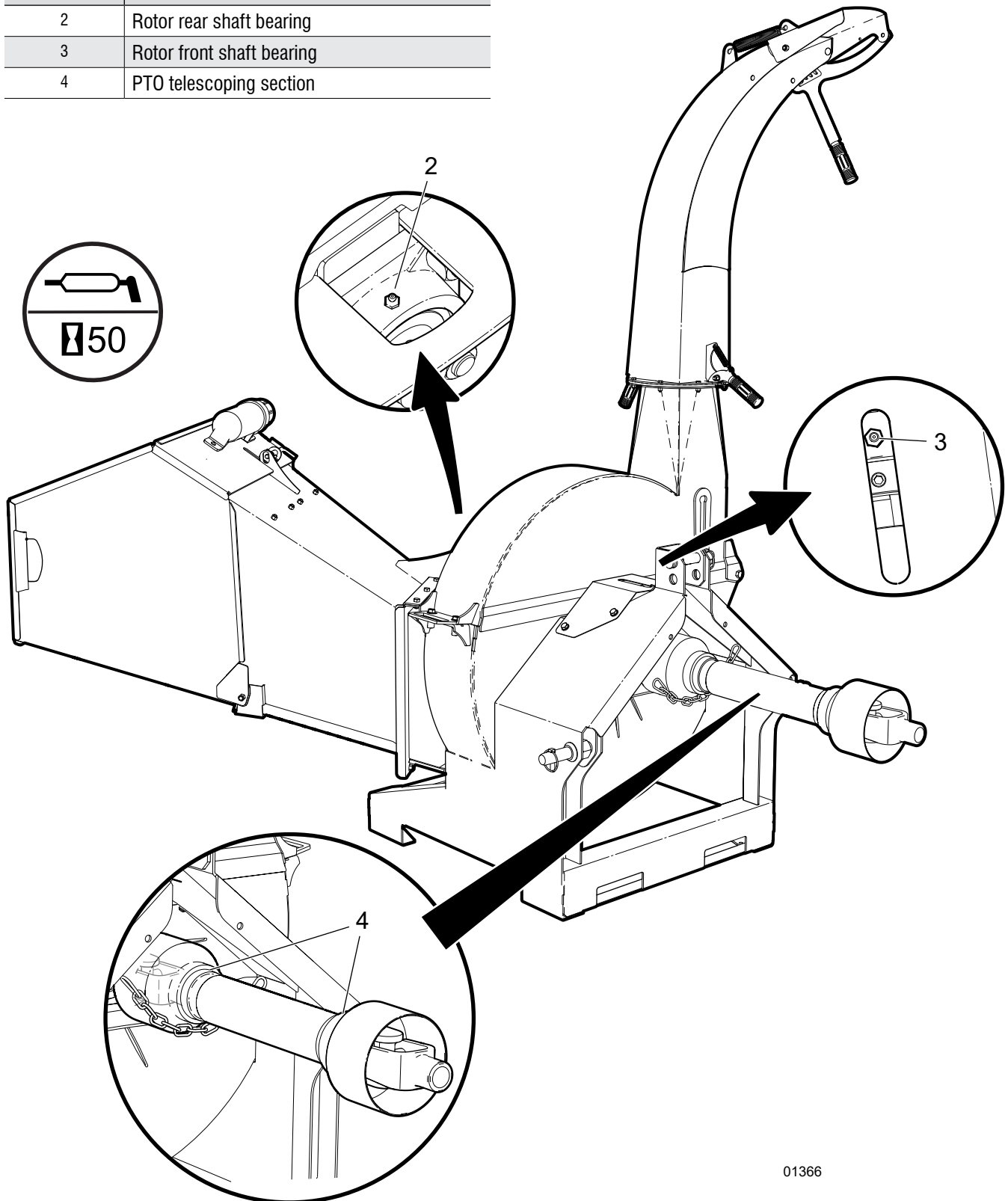

Fig. 36– 8-hour Grease Points

### Grease Points

Location	Every 50 hours or annually
2	Rotor rear shaft bearing
3	Rotor front shaft bearing
4	PTO telescoping section



01366

Fig. 37–50-hour Grease Points

## 8.4 PTO Shaft Maintenance

Grease the PTO shaft every 8 hours.

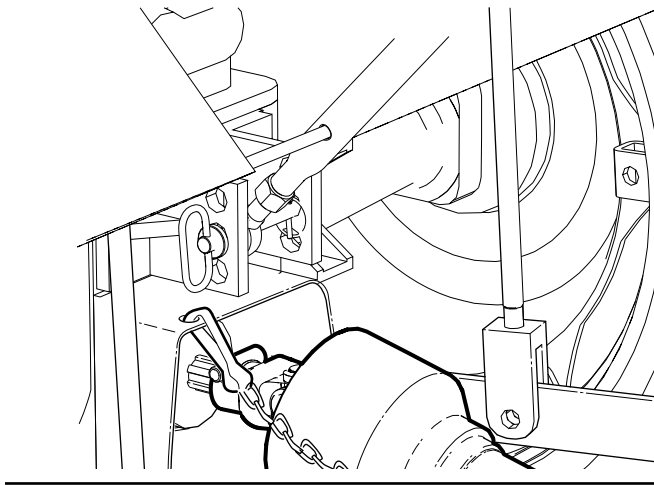

Fig. 38—PTO Shaft

The PTO shaft is designed to collapse and extend as the machine goes through its operational range.

Heavy-duty plastic shielding encloses the driving components. As a safety measure, it is designed to stay stationary as the drive shaft turns.

Annual disassembly, cleaning and inspection is recommended to make sure that all components function as intended.

### Shear Bolt

The PTO shaft has a shear bolt on the implement end, at the input yoke. The shear bolt is designed to break in the event the drive system is overloaded to protect other critical components.

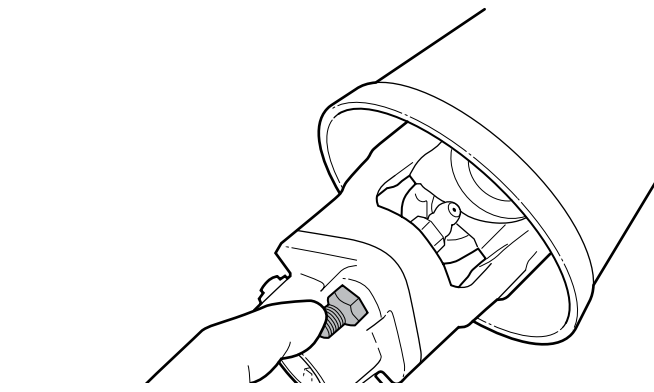

Fig. 39—PTO Shear Bolt

The drive system is designed to function well without failing the shear bolt. If it does fail, generally it is because material is being fed too fast or something very hard has been jammed into the rotor or between the blades.

Replace broken shear bolts with one the same size. Always determine the cause of the problem and correct it before resuming work. Shear bolts are available from your distributor or dealer.

## 8.5 Twig Breaker

Inspect the twig breaker for damage, bent or missing teeth every 50 hours.

The twig breaker is located inside the lower rotor housing. Material in the chipper is broken up into smaller pieces as the discharge paddles rotate past it.

A damaged or worn twig breaker should be replaced.

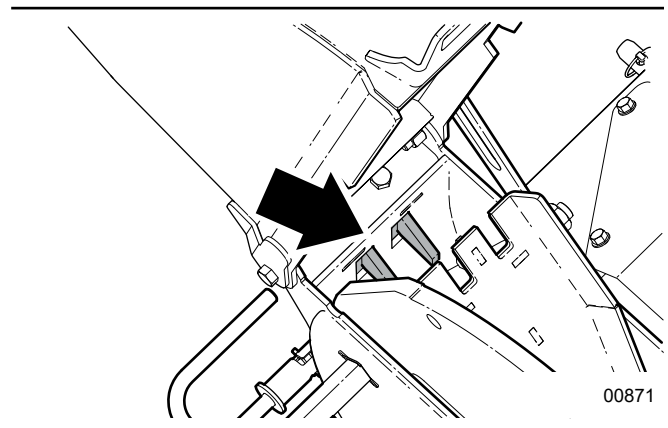

Fig. 40—Twig Breaker

## 8.6 Rotor Blades

### Check rotor blade sharpness daily.

If the chipper is not pulling the material or material has to be pushed into the chipper, the rotor blades are probably dull. Reverse or sharpen the blades if the cutting edge becomes dull.

Check blade sharpness more often if processing material with a lot of sand, soil or dirt in it.

Keeping the blades sharp reduces the amount of power required during operation.

### Sharpening Rotor Blades

1. Remove the blades from the rotor to sharpen. Sharpen at a 45° angle to provide the best cutting effect.

**IMPORTANT!** Make sure equal amount of material is removed from each blade when sharpening to maintain proper rotor balance.



**CAUTION!**

**Risk of getting hands pinched or wedged between lower rotor housing and rotor. Turn rotor slowly and be aware of hand positioning.**

W032

2. Install rotor blades with leading edge out, towards the ledger blade. Tighten the blade mounting bolts.

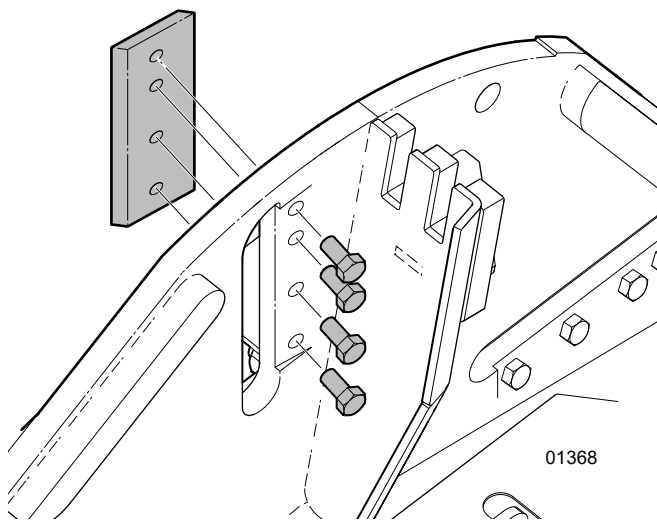

Fig. 41 – Changing rotor blade

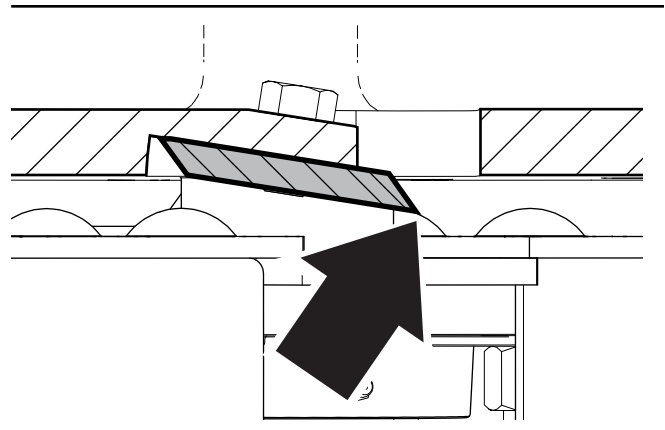

Fig. 42 – Rotor blade leading edge

## 8.7 Ledger Knife

**Observe ledger knife performance daily. Check the ledger knife sharpness every 50 hours.**

The ledger knife is bolted inside the lower rotor housing assembly. As the rotor turns, material fed into the chipper is sheared off at the ledger knife by the rotor blades.

When the corner of the ledger knife facing the rotor blade rounds over, the blade can be removed and re-installed with a different corner facing the rotor blade. Once all four corners have been rounded, remove the knife to sharpen or replace it.

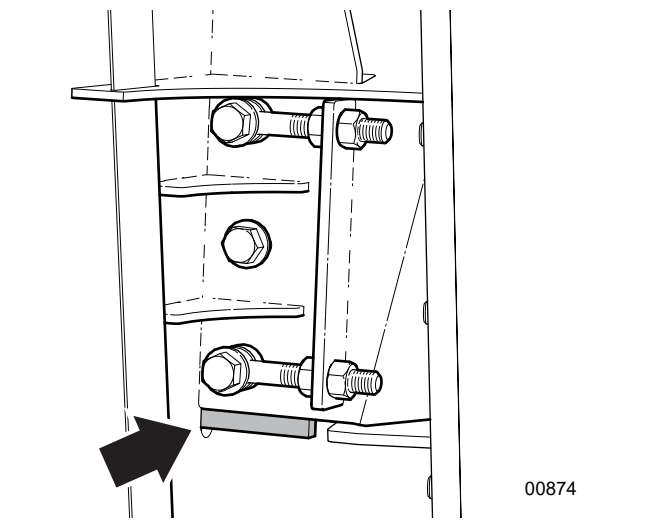

Fig. 43 – Ledger knife inside lower rotor housing

**To obtain the best chipper performance, check the clearance between the rotor blade and stationary ledger blade every 50 hours.**

### 8.7.1 Ledger Knife Clearance

Use the Ledger Setting Gauge to check knife clearance. **The thickness of the gauge is the correct ledger blade clearance.** If spacing is in excess of the gauge thickness, adjust the clearance.



*The actual clearance between the rotor blades and the ledger knife is 1/32"–1/16" (3/4 – 1-1/2 mm).*

#### Checking

1. Open the upper rotor housing.



**Risk of getting hands pinched or wedged between lower rotor housing and rotor. Turn rotor slowly and be aware of hand positioning.**

W032

2. Turn the rotor by hand so that one rotor blade edge is next to the ledger knife.
3. Slide the end of the ledger gauge down between the rotor blade and the ledger knife.

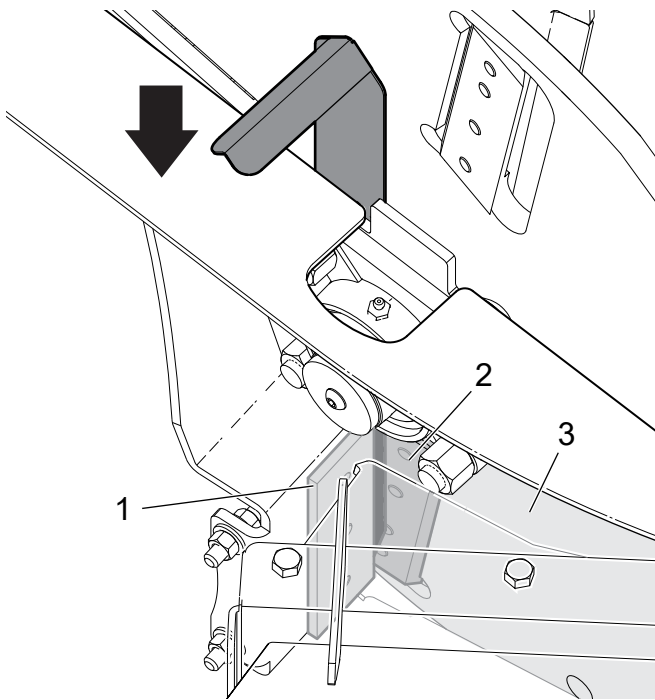

**Fig. 44**—Inserting Gauge

1. Ledger Knife
2. Rotor Blade
3. Rotor

4. Turn the rotor past the ledger knife with the gauge inserted between them to check clearance. The gauge should be tight. Check all four knives.

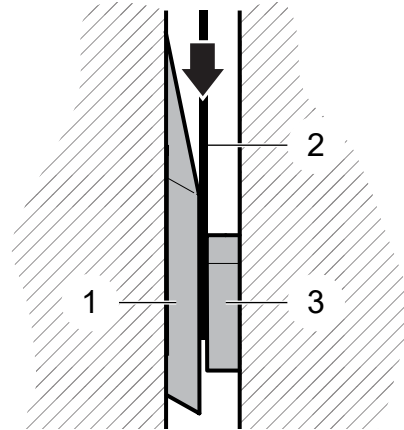

**Fig. 45**—Checking ledger knife clearance

1. Rotor Blades
2. Gauge
3. Ledger Knife

#### Adjusting – BX36S

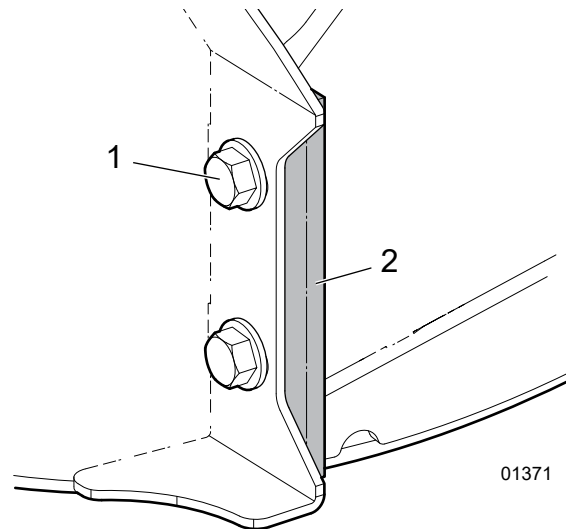
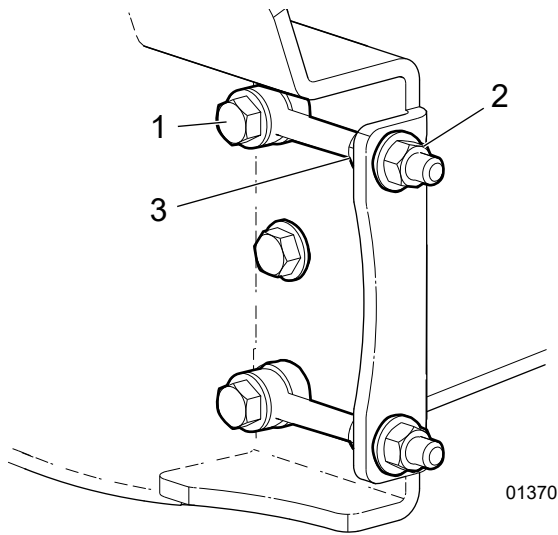

**Fig. 46**—BX36S Ledger Knife

1. Loosen off the securing bolts (1)
2. Adjust the Ledger Blade (2) inward so the spacing is correct. If using the gauge, snug the blade up against the gauge.
3. Tighten the securing bolts and remove the gauge.

**Adjusting – All other models**

(BX52S shown. Other models similar.)

**Fig. 47** – Adjusting Ledger Knife

1. Securing Bolts
2. Jam Nuts
3. Adjusting Nuts

1. Loosen the securing bolts (1).
2. Loosen the jam nuts on the outside of the ledger knife support (2).
3. Turn the adjuster nuts (3) clockwise so the ledger knife slides firmly up against the gauge inside the rotor housing. Move both adjusters evenly.
4. Remove the ledger knife gauge. Tighten the jam nuts. Tighten the securing bolts.

**Changing Ledger Knife**

(BX52S shown. Other models similar.)

**Procedure**

Remove the securing bolts to remove the ledger blade.

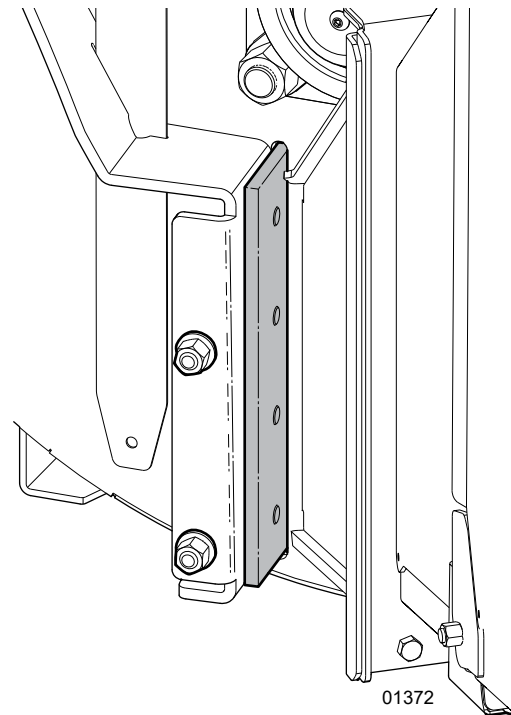
**Fig. 48** – Changing Ledger Knife

5. Rotate the ledger knife or replace it with a new or sharpened knife.
6. Hand-tighten the bolts.
7. Verify clearance before tightening. See page 37.

## 9. Troubleshooting

The following table lists some problems that may be encountered, with possible causes and solutions.

If a problem persists after reading through the Troubleshooting section, contact your local dealer, distributor or Wallenstein. Have the serial number ready.

Problem	Cause	Solution
<b>Rotor does not turn</b>	Obstructed discharge.	Clear debris from discharge chute.
	Rotor plugged.	Inspect and clear chipper hopper lower rotor housing and rotor.
	Broken shear bolt.	Replace it with a shear bolt that is the correct size and hardness. See the chipper Parts Manual.
<b>Material feeding in too slow</b>	Engine or rotor speed too low.	Set throttle to increase rotor rpm.
	Blades or knives are dull or clearance is incorrect.	Check rotor and ledger blades. Rotate, sharpen or replace. See page 36.
	Rotor blade knife edge angle incorrect.	Resharpener the rotor knives to specified 45° angle and check that blade is installed properly. See page 36.
	Obstructed discharge.	Clear debris from discharge chute.
<b>Unusual machine vibration while operating</b>	Broken or missing rotor blade.	Replace the rotor blade. See page 36.
	Rotor may be bent.	Check for rotor wobble. Replace the rotor.
	Rotor bearings failed.	Replace the rotor bearings.
	Loose fasteners.	Tighten fasteners to the correct torque. See page 41.
	PTO shaft yokes are out of phase. (It is recommended that Binacchi® PTO shafts are used to prevent this from occurring).	Set the yokes on each end of the PTO shaft to the same phase.
<b>Poor Chip Quality</b>	Dull blades.	Check rotor and ledger blades. Rotate, sharpen or replace. See page 36.
	Poor quality material.	Material is small or rotting. Mix with higher quality material.
	Space between the rotor blades and ledger knife is too large.	Use the ledger guide tool to check the clearance. See page 37.
<b>Machine requires excessive power or stalls</b>	Obstructed discharge.	Clear debris from discharge chute.
	Feeding in too much material.	Feed smaller amounts into the chipper hopper.
	Feeding material too quickly.	Feed larger material slowly into the chipper hopper.
	Rotor plugged.	Inspect and clear chipper hopper lower rotor housing and rotor.
	Green material does not discharge.	Allow material to dry or alternate between dry and wet material.
	Space between the rotor blades and ledger knife is too large.	Use the ledger guide tool to check the clearance. See page 37.
	Dull blades.	Check rotor and ledger blades. Rotate, sharpen or replace. See page 36.
<b>PTO shear bolt breaking</b>	Tractor cruise control function is on.	Turn off the tractor cruise control.
	Rotor knives are dull.	Rotate, sharpen, or replace the rotor knives. See page 36.
	Space between the rotor blades and ledger knife is too large.	Use the ledger guide tool to check the clearance. See page 37.
	Tractor PTO speed is set too low.	Increase the PTO speed to 540 or 1,000 rpm.
	PTO shaft angle is incorrect.	Adjust the PTO shaft angle to 15° or less from horizontal. See page 22.
	Shear bolt is incorrect.	Replace it with a shear bolt that is the correct size and hardness. See the chipper Parts Manual.
	Chipper is not on the ground.	Place the chipper on the ground.
	Three-point hitch is raised or lowered, while the chipper rotor is turning.	Wait for the chipper rotor to stop turning before raising or lowering the chipper.
	Tractor PTO spline and chipper PTO spline are not on parallel planes.	Adjust the toplink to align the tractor and chipper PTO spline planes.
	PTO shaft is too long.	Cut the PTO shaft to the correct length. See page 19.
	PTO shaft yokes are out of phase. (It is recommended that Binacchi® PTO shafts are used to prevent this from occurring).	Set the yokes on each end of the PTO shaft to the same phase.

# 10. Specifications

## 10.1 Machine Specifications<sup>1</sup>

Model	BX36S	BX52S	BX72S	BX102S
Drive System	Direct Drive, PTO with shear bolt	Direct Drive, PTO with shear bolt	Direct Drive, PTO with shear bolt	Direct Drive, PTO with shear bolt
HP Range	12–30 hp 9–22 kW	22–55 hp 16–41 kW	50–85 hp 37–63 kW	80–120 hp 60–89 kW
Chipper Capacity (diameter)	3.5" 9 cm	5" 13 cm	7" 17 cm	10" 25 cm
Chipper Housing Opening	3.5" x 9" 9 cm x 23 cm	5" x 10" 13 cm x 26 cm	7" x 12" 17 cm x 30 cm	10" x 15" 25 cm x 38 cm
Rotor Size	25" 63.5 cm	25" 63.5 cm	28" 71 cm	36" 91 cm
Number of Rotor Knives	4 segmented knives	4 segmented knives	4 full knives	4 segmented knives
Knife Type	4-bolt hardened / reversible	4-bolt hardened / reversible	4-bolt hardened / reversible	3-bolt hardened / reversible
Rotor Weight	96 lb 43.5 kg	125 lb 56.7 kg	175 lb 79.3 kg	400 lb 181.4 kg
Feeding System	Manual Feed	Manual Feed	Manual Feed	Manual Feed
PTO height (from ground)	13.44"–19.0" (adjustable) 34.13–42.26 cm	13.44"–19.0" (adjustable) 34.13–42.26 cm	19.0" 42.26 cm	23.0" 58.42 cm
Mounting System	3-Point Hitch Cat I (iMatch™ and Quick Hitch compatible)	3-Point Hitch Cat I (iMatch™ and Quick Hitch compatible)	3-Point Hitch Cat I (iMatch™ and Quick Hitch compatible)	3-Point Hitch Cat II (iMatch™ and Quick Hitch compatible)
Weight	395 lb 179 kg	505 lb 229 kg	728 lb 330.2 kg	1143 lb 518.5 kg
Dimensions (L x W x H)	55" x 45" x 60" 140 cm x 114 cm x 152 cm	43" x 55" x 66" 110 cm x 140 cm x 168 cm	64" x 70" x 82" 163 cm x 178 cm x 208 cm	71" x 71" x 89" 180 cm x 180 cm x 226 cm
Discharge Hood Rotation	360°	360°	360°	360°
Discharge Hood Height	60" 152 cm	66" 168 cm	82" 208 cm	89" 226 cm
Rated Speed	540–1000 rpm	540–1000 rpm	540–1000 rpm	540–1000 rpm
Standard Features	<ul style="list-style-type: none"> <li>Aggressive Self Feed System</li> <li>Multi Position, Locking Discharge Chute</li> <li>Reversible Rotor Blades</li> <li>Reversible Ledger Knife</li> <li>Manual Feed Hopper</li> <li>Ledger Knife Spacer Tool</li> <li>Bearing Protection Plates</li> <li>Four-position Rotor Lock</li> <li>Adjustable Ski Base</li> <li>Single Blade Twig Breaker</li> <li>270° Single Handle Exit Chute Rotation</li> <li>Dual Knob Easy Change Discharge Deflector</li> <li>Three-position Select 3-PH Lift Arm Width</li> </ul>	<ul style="list-style-type: none"> <li>Aggressive Self Feed System</li> <li>Multi Position, Locking Discharge Chute</li> <li>No Tools Fold Up Feed Hopper with latch</li> <li>Reversible Rotor Blades</li> <li>Reversible Ledger Knife</li> <li>Manual Feed Hopper</li> <li>Ledger Knife Spacer Tool</li> <li>Bearing Protection Plates</li> <li>Positive Adjust Ledger Knife</li> <li>Four-position Rotor Lock</li> <li>Adjustable Ski Base</li> <li>Dual Blade Twig Breaker</li> <li>270° Dual Handle Exit Chute Rotation</li> <li>Single Handle Easy Change Discharge Deflector</li> <li>Three Position Select 3-PH Lift Arm Width</li> </ul>	<ul style="list-style-type: none"> <li>Aggressive Self Feed System</li> <li>Multi Position, Locking Discharge Chute</li> <li>No Tools Fold Up Feed Hopper with latch</li> <li>Reversible Rotor Blades</li> <li>Reversible Ledger Knife</li> <li>Manual Feed Hopper</li> <li>Ledger Knife Spacer Tool</li> <li>Bearing Protection Plates</li> <li>Positive Adjust Ledger Knife</li> <li>Four-position Rotor Lock</li> <li>Dual Blade Twig Breaker</li> <li>270° Dual Handle Exit Chute Rotation</li> <li>Single Handle Easy Change Discharge Deflector</li> <li>Three Position Select 3-PH Lift Arm Width</li> </ul>	<ul style="list-style-type: none"> <li>Aggressive Self Feed System</li> <li>Multi Position, Locking Discharge Chute</li> <li>No Tools Fold Up Feed Hopper with latch</li> <li>Reversible Rotor Blades</li> <li>Reversible Ledger Knife</li> <li>Manual Feed Hopper</li> <li>Ledger Knife Spacer Tool</li> <li>Bearing Protection Plates</li> <li>Positive Adjust Ledger Knife</li> <li>Four-position Rotor Lock</li> <li>Dual Blade Twig Breaker</li> <li>270° Dual Handle Exit Chute Rotation</li> <li>Single Handle Easy Change Discharge Deflector</li> <li>Three Position Select 3-PH Lift Arm Width</li> </ul>

<sup>1</sup> Specifications are subject to change without notice.



## 10.2 Common Bolt Torque Values

### Checking Bolt Torque

The tables shown give correct torque values for various bolts and capscrews. Tighten all bolts to the torque values specified in the table, unless indicated otherwise. Check tightness of bolts periodically.

**IMPORTANT!** If replacing hardware, use fasteners of the same grade.

**IMPORTANT!** Torque figures indicated in the table are for non-greased or non-oiled threads. Do not grease or oil threads unless indicated otherwise. When using a thread locker, increase torque values by 5%.



*Bolt grades are identified by their head markings.*

Imperial Bolt Torque Specifications						
Bolt Diameter	Torque Value					
	SAE Gr. 2		SAE Gr. 5		SAE Gr. 8	
	lbf·ft	N·m	lbf·ft	N·m	lbf·ft	N·m
1/4"	6	8	9	12	12	17
5/16"	10	13	19	25	27	36
3/8"	20	27	33	45	45	63
7/16"	30	41	53	72	75	100
1/2"	45	61	80	110	115	155
9/16"	60	95	115	155	165	220
5/8"	95	128	160	215	220	305
3/4"	165	225	290	390	400	540
7/8"	170	230	420	570	650	880
1"	225	345	630	850	970	1320



Metric Bolt Torque Specifications				
Bolt Diameter	Torque Value			
	Gr. 8.8		Gr. 10.9	
	lbf·ft	N·m	lbf·ft	N·m
M3	0.4	0.5	1.3	1.8
M4	2.2	3	3.3	4.5
M6	7	10	11	15
M8	18	25	26	35
M10	37	50	52	70
M12	66	90	92	125
M14	83	112	116	158
M16	166	225	229	310
M20	321	435	450	610
M30	1,103	1 495	1,550	2 100



## 11. Product Warranty



### LIMITED WARRANTY

Wallenstein products are warranted to be free of defects in materials and workmanship under normal use and service, for a period of

**Five Years for Consumer Use**

**Two Years for Commercial/Rental Use**

from the date of purchase, when operated and maintained in accordance with the operating and maintenance instructions supplied with the unit. Warranty is limited to the repair of the product and/or replacement of parts.

This warranty is extended only to the original purchaser and is not transferable.

Repairs must be done by an authorized dealer. Products will be returned to the dealer at the customer's expense. Include the original purchase receipt with any claim.

**This warranty does not cover the following:**

- 1) Normal maintenance or adjustments
- 2) Normal replacement of wearable and service parts
- 3) Consequential damage, indirect damage, or loss of profits
- 4) Damages resulting from:
  - Misuse, negligence, accident, theft or fire
  - Use of improper or insufficient fuel, fluids or lubricants
  - Use of parts or aftermarket accessories other than genuine Wallenstein parts
  - Modifications, alteration, tampering or improper repair performed by parties other than an authorized dealer
  - Any device or accessories installed by parties other than an authorized dealer
- 5) Engines. Engines are covered by the manufacturer of the engine for the warranty period they specify. For the details of your engine warranty, see your engine owner's manual. Information about engine warranty and service is also available in the FAQ section at [www.wallensteinequipment.com](http://www.wallensteinequipment.com)

## 12. Alphabetical Index

<b>A</b>		Shear Bolt..... 35
Attach to a Tractor..... 18		Size..... 19
<b>C</b>		<b>R</b>
Common Bolt Torque Values..... 41		Replace Damaged Safety Signs ..... 14
Connect 3-point Hitch..... 18		Rotor Blades ..... 36
Controls..... 23		Sharpening ..... 36
Discharge Chute..... 23		Rotor does not turn ..... 39
Discharge Chute Deflector..... 23		Rotor Lock..... 24
Rotor Lock ..... 24		Set Rotor Lock..... 24
<b>D</b>		<b>S</b>
Delivery Inspection Report..... 4		Safety ..... 7
Discharge Chute ..... 23		How to Install Safety Signs ..... 14
Discharge Chute Deflector..... 23		Safe Condition ..... 9
<b>E</b>		Safety Alert Symbol ..... 7
Equipment Safety Guidelines..... 8		Signal Words ..... 7
<b>F</b>		Safety Alert Symbol..... 7
Familiarization ..... 15		Safety Rules..... 8
Operator Orientation ..... 15		Safety Signs ..... 11
To the New Operator or Owner..... 15		Safety Sign Explanations..... 13
<b>G</b>		Safety Sign Locations ..... 11
Grease Points ..... 33		Safety Sign Replacement ..... 14
Grease Type..... 32		Serial Number ..... 5
<b>L</b>		Service and Maintenance..... 32
Ledger Knife – Changing ..... 38		Ledger Knife – Changing ..... 38
Ledger Knife – Checking..... 36		Ledger Knife – Checking ..... 36
<b>M</b>		Ledger Knife Clearance..... 37
Machine Break-In..... 27		PTO Shaft Maintenance ..... 35
Machine requires excessive power or stalls..... 39		Shear Bolt..... 35
Machine Set-up ..... 26		Rotor Blades – Changing..... 36
Maintenance Schedule..... 33		Twig Breaker..... 35
Material feeding in too slow..... 39		Setting Rotor Lock..... 24
<b>O</b>		Sharpening Rotor Blades ..... 36
Operating Instructions		Shear Bolt ..... 35
Adjust Ski Height ..... 26		Specifications ..... 40
Chipper Plugged..... 28		Bolt torque ..... 41
Chipping Operation..... 28		Starting Procedure ..... 27
Machine Break-In..... 27		Stopping..... 27
Machine Set-up..... 26		Stopping in an Emergency..... 27
Pre-Operation Checklist..... 27		Storage
Starting Procedure..... 27		Removing from Storage..... 31
Stopping..... 27		Stowing the Feed Hopper ..... 30
Stopping in an Emergency..... 27		<b>T</b>
Operator Orientation ..... 15		Three-point Hitch
<b>P</b>		Category I and II ..... 18
Plugged Chipper ..... 28		Connect ..... 18
Poor Chip Quality..... 39		Transporting ..... 30
Pre-Operation Checks..... 27		Prepare for Transport..... 30
Prepare for Transport..... 30		Troubleshooting Guide..... 39
PTO Shaft		Twig Breaker ..... 35
Install ..... 22		<b>U</b>
<b>U</b>		Unusual machine vibration while operating..... 39
<b>W</b>		<b>W</b>
<b>W</b>		Warranty..... 42



[WallensteinEquipment.com](http://WallensteinEquipment.com)