

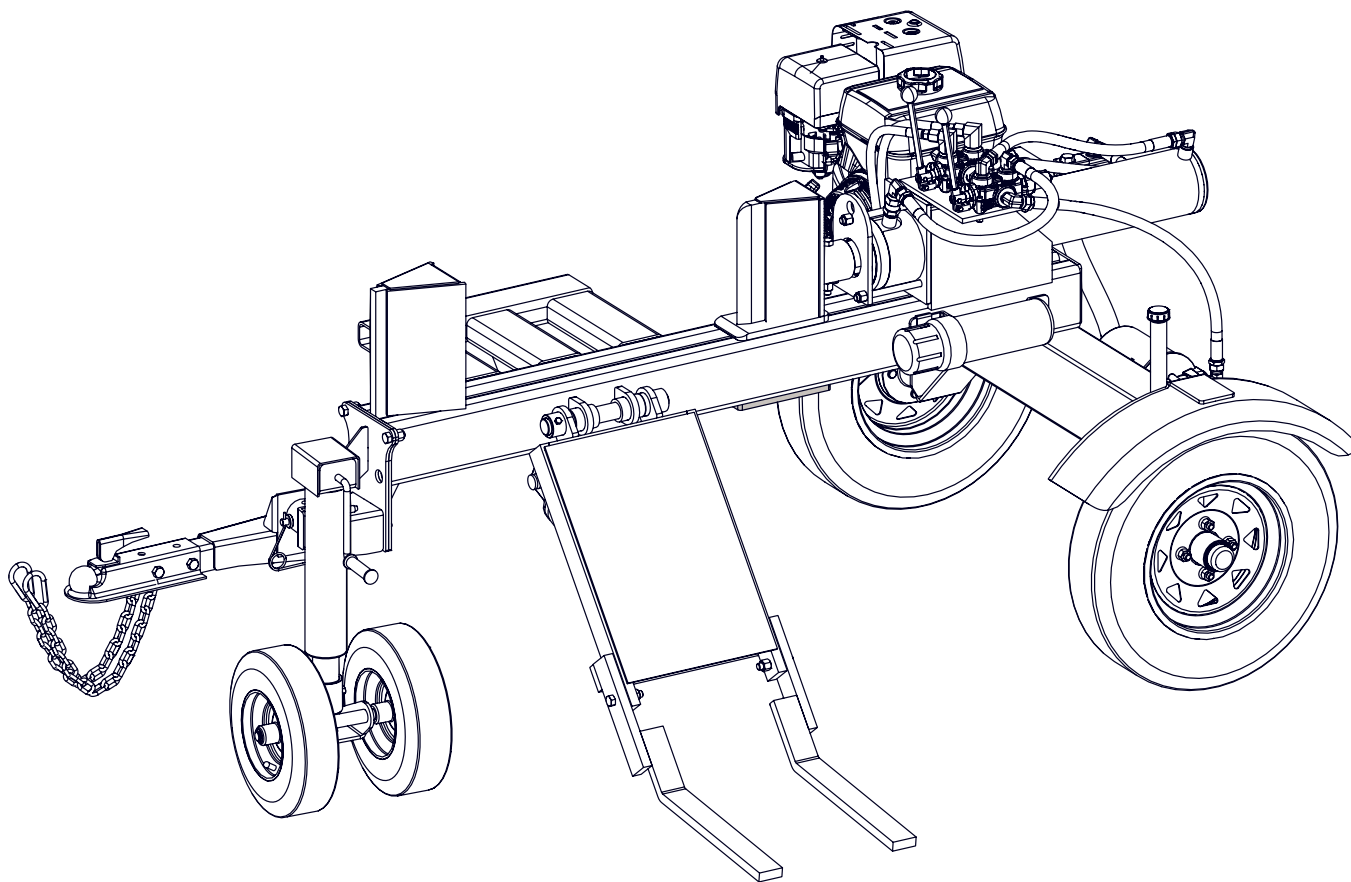

EMB Manufacturing Inc.  
4144 Boomer Line · St. Clements, On · N0B 2M0 · Canada  
Ph: (519) 699-9283 · Fax: (519) 699-4146  
www.wallensteinequipment.com

# WX950 Trailer Log Splitter Parts Manual

Starting with S/N 2E9US1111ES350072 & After  
350117 & After



Refer to the operators  
manual for safe  
operation and  
maintenance

## Foreword

EMB Mfg. has prepared this parts manual to assist customers in ordering quality OEM replacement parts.

Proper and regular service and replacing old, worn or broken parts with the correct OEM parts are essential to prolonging the life of your EMB product. Please refer to this manual before ordering any replacement parts.

All information contained in this parts manual is based on the latest product specification available at the time of printing this manual. If your product differs from the specifications contained within this manual contact EMB Mfg. for information.

EMB reserves the right to alter specifications on their products at any time.

Reproduction of this parts manual of any kind is prohibited without prior written permission from EMB Mfg.

For parts and information please contact your dealer. If your dealer is no longer available please go to our website: <http://www.wallensteinequipment.com> and click on "FIND A DEALER NEAR YOU" for information on a local dealer.

# Table of Contents

**Bolt Torque..... 4**

**Hydraulic Fitting Torque ..... 5**

**Wheel Lug Torque ..... 5**

**Main Parts..... 6**

**Hitch & Tongue..... 7**

**Dual Jockey Jack Assembly ..... 8**

**Sliding Wedge Assembly ..... 9**

**Hub Assembly ..... 10**

**Engine and Hydraulics Assembly ..... 10**

**Sliding Wedge Cylinder ..... 11**

**Lift Shelf Cylinder ..... 11**

**Valve Assembly..... 12**

**Z56209 Service Kits ..... 12**

**Z56211 Service Kits ..... 12**

**Hydraulic Schematic..... 13**

**Hydraulic Hose List ..... 13**

**Label Layout..... 14**

**Accessories..... 15**

Maintenance should be performed by trained personnel only.



Refer to the operators manual for safe operation and maintenance

**Bolt Torque**

**CHECKING BOLT TORQUE**

The tables shown below give correct torque values for various bolts and capscrews. Tighten all bolts to the torques specified in chart unless otherwise noted. Check tightness of bolts periodically, using bolt torque chart as a guide. Replace hardware with the same strength bolt.

**ENGLISH TORQUE SPECIFICATIONS**

Bolt Diameter "A"	Bolt Torque*					
	SAE 2 (N.m) (lb-ft)		SAE 5 (N.m) (lb-ft)		SAE 8 (N.m) (lb-ft)	
1/4"	8	6	12	9	17	12
5/16"	13	10	25	19	36	27
3/8"	27	20	45	33	63	45
7/16"	41	30	72	53	100	75
1/2"	61	45	110	80	155	115
9/16"	95	60	155	115	220	165
5/8"	128	95	215	160	305	220
3/4"	225	165	390	290	540	400
7/8"	230	170	570	420	880	650
1"	345	225	850	630	1320	970

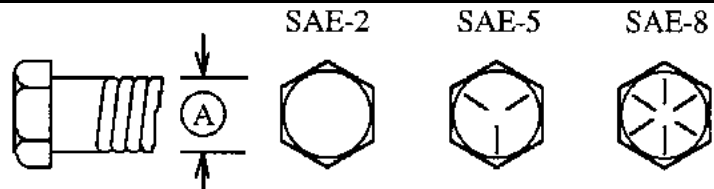

Torque figures indicated above are valid for non-greased or non-oiled threads and heads unless otherwise specified. Therefore, do not grease or oil bolts or capscrews unless otherwise specified in this manual. When using locking elements, increase torque values by 5%.

\* Torque value for bolts and capscrews are identified by their head markings.

**METRIC TORQUE SPECIFICATIONS**

Bolt Diameter "A"	Bolt Torque*			
	8.8 (N.m) (lb-ft)		10.9 (N.m) (lb-ft)	
M3	0.5	0.4	1.8	1.3
M4	3	2.2	4.5	3.3
M5	6	4	9	7
M6	10	7	15	11
M8	25	18	35	26
M10	50	37	70	52
M12	90	66	125	92
M14	140	103	200	148
M16	225	166	310	229
M20	435	321	610	450
M24	750	553	1050	774
M30	1495	1103	2100	1550
M36	2600	1917	3675	2710

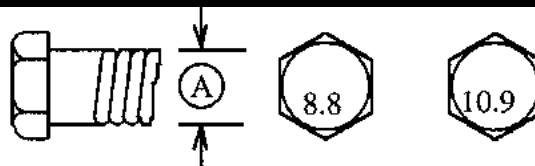

### Hydraulic Fitting Torque

#### Tightening Flare Type Tube Fittings \*

1. Check flare and flare seat for defects that might cause leakage.
2. Align tube with fitting before tightening.
3. Lubricate connection and hand tighten swivel nut until snug.
4. To prevent twisting the tube(s), use two wrenches. Place one wrench on the connector body and with the second tighten the swivel nut to the torque shown.

Tube Size OD (in.)	Nut Size Across Flats (in.)	Torque Value*		Recommended Turns To Tighten (After Finger Tightening)	
		(N.m)	(lb-ft)	(Flats)	(Turn)
3/16	7/16	8	6	1	1/6
1/4	9/16	12	9	1	1/6
5/16	5/8	16	12	1	1/6
<b>3/8</b>	<b>11/16</b>	<b>24</b>	<b>18</b>	<b>1</b>	<b>1/6</b>
1/2	7/8	46	34	1	1/6
5/8	1	62	46	1	1/6
3/4	1-1/4	102	75	3/4	1/8
7/8	1-3/8	122	90	3/4	1/8

The torque values shown are based on lubricated connections as in reassembly.

### Wheel Lug Torque

It is extremely important safety procedure to apply and maintain proper wheel mounting torque on your trailer axle. Torque wrenches are the best method to assure the proper amount of torque is being applied to a fastener.

Wheel lugs should be torqued before first road use and after each wheel removal. Check and re torque after the first 16Km (10 miles), 40Km (25 miles), and again at 80Km (50 miles). Check periodically thereafter.

Note: Wheel lugs must be applied and maintained at the proper torque levels to prevent loose wheels, broken studs, and possible dangerous separation of wheels from your axle.

- Start all lugs by hand to prevent cross threading.
- Tighten lugs in sequence, per wheel lug torque sequence chart.
- The tightening of the fasteners should be done in stages. Following the recommended sequence, tighten fasteners per wheel torque requirements chart.

Wheel Torque Requirements				
Wheel Size	Torque Unit	1st Stage	2nd Stage	3rd Stage
8"	ft-lbs	12 - 20	30 - 35	45 - 55
	Nm	16 - 26	39 - 45.5	58.5 - 71.5
12"	ft-lbs	20 - 25	35 - 40	50 - 60
	Nm	26 - 32.5	45.5 - 52	65 - 78
13"	ft-lbs	20 - 25	35 - 40	50 - 60
	Nm	26 - 32.5	45.5 - 52	65 - 78
14"	ft-lbs	20 - 25	50 - 60	90 - 120
	Nm	26 - 32.5	65 - 78	117 - 156
15"	ft-lbs	20 - 25	50 - 60	90 - 120
	Nm	26 - 32.5	65 - 78	117 - 156
16"	ft-lbs	20 - 25	50 - 60	90 - 120
	Nm	26 - 32.5	65 - 78	117 - 156

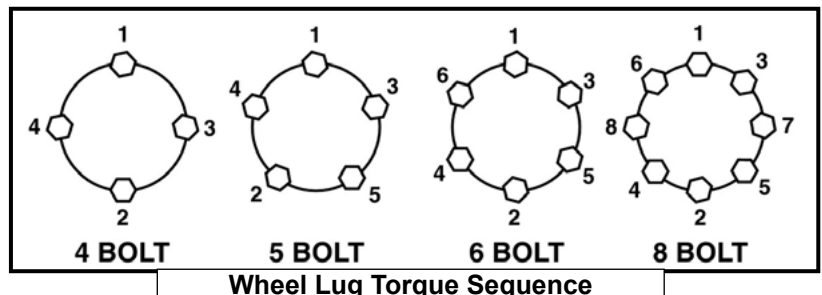

BOM ID	Part No.	Description	Qty
1	2058W821	Weldment, WX950 Trailer	1
2	2058W813	Weldment, Lift Shelf	1
3	2058W810	Weldment, WX950 Log Arm	1
4	2058C801	Cylinder, 3-1/2 x 8 X 1-1/2	1
5	Z91202	Idle Hub Assy, 1000lbs x 4 on 4" x 1" 2	2
6	2058W811	Weldment, Fender	2
7	Z91302	5.30-12 LRB Sport Trail 4on4"	2
8	Z55303	Particulate Filter, FP16	1
9	Z51223	Straight, MP x FP 1608	1
10	Z11141	Toplink Pin, 1" x 3-3/16" MOD	2
11	Z55304	Filter Cap, MP16 x FP16	1
12	Z55404	Vented Plug Dipstick x 9"	1
13	Z96503	Manual Tube, 3-1/2" Short	1
14	Z71560	Hex Bolt, 1/2NC x 6"	3
15	Z75114	SHCS, 1/4NC x 1-3/4"	6
16	2061A103	Assy, 9hp Engine to 16gpm Pump	1
17	2032S213	Plate, Cylinder Retaining	1
18	2055C501	Cylinder, 4-1/2 x 24 x 2-1/2	1
19	2054L412	Clamp, Two Hose	2
20	2058W815	Pin, Shelf Pivot	1
21	Z12140	Lynch Pin, 7/16"	2
22	Z51135	Elbow 90, MP x FP 0606	1
23	Z51312	Straight, MP x FPX 0808	1
24	Z51331	Elbow 90, MP x FPX 0808	3
25	Z71122	Hex Bolt, 1/4NC x 2-1/4"	1
26	2058A802	Wedge for WX950	1
27	Z71525	Hex Bolt, 1/2NC x 2-1/2	2
28	Z72211	Hex Lock Nut, 1/4NC	7
29	Z72221	Hex Lock Nut, 5/16NC	3
30	Z72231	Hex Lock Nut, 3/8NC	4
31	Z72251	Hex Lock Nut, 1/2NC	5
32	Z76231	Carriage Bolt, 3/8NC x 1"	4
33	Z79401	Hose Clamp, SAE #16 (1-1/2")	2

On Models with Hydraulic Tank Drain:  
#Z51192 Socket Plug, MP 08

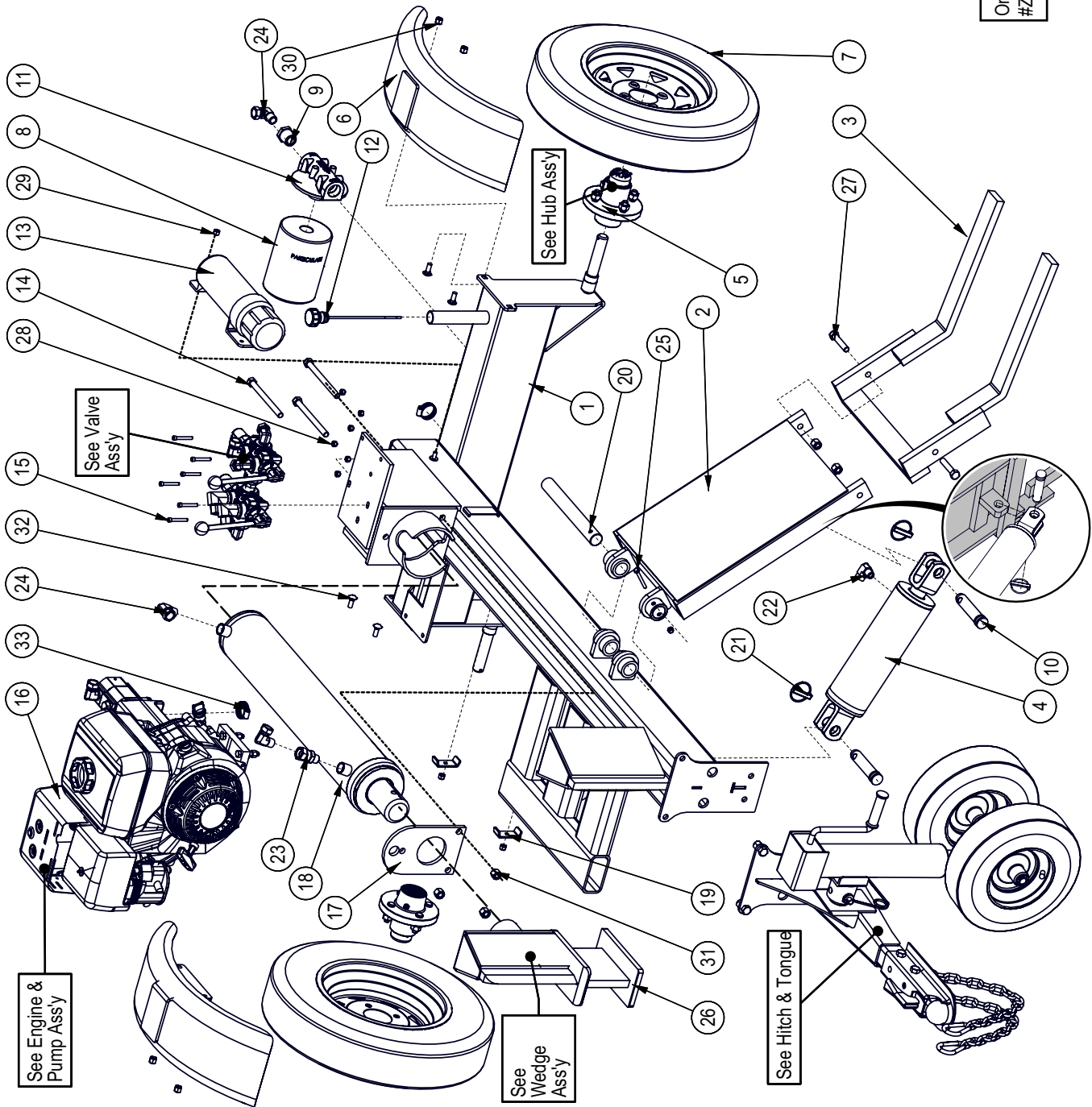

Main Parts

See Engine & Pump Assy

See Valve Assy

See Wedge Assy

See Hitch & Tongue

**Hitch & Tongue**

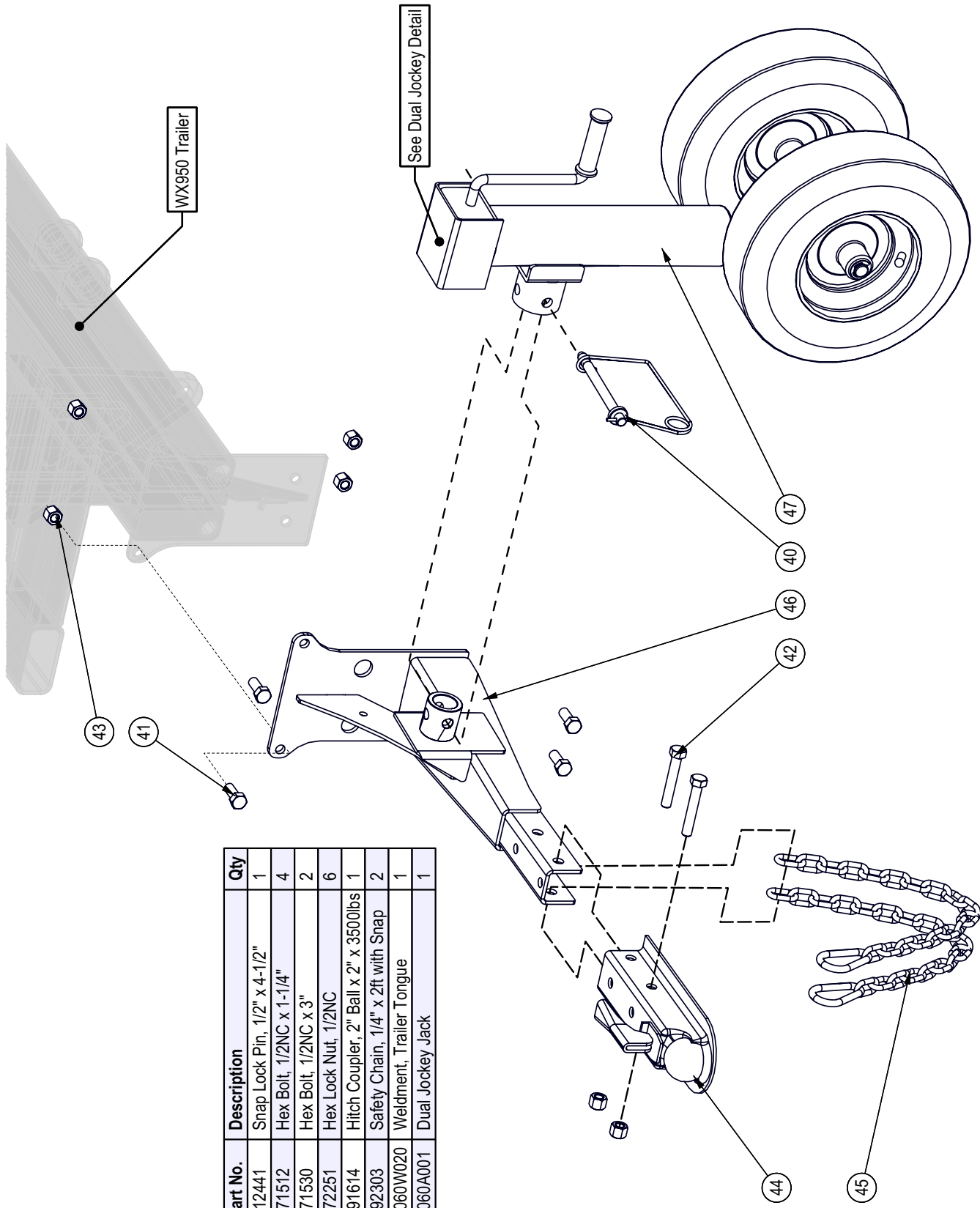

BOM ID	Part No.	Description	Qty
40	Z12441	Snap Lock Pin, 1/2" x 4-1/2"	1
41	Z71512	Hex Bolt, 1/2NC x 1-1/4"	4
42	Z71530	Hex Bolt, 1/2NC x 3"	2
43	Z72251	Hex Lock Nut, 1/2NC	6
44	Z91614	Hitch Coupler, 2" Ball x 2" x 3500lbs	1
45	Z92303	Safety Chain, 1/4" x 2ft with Snap	2
46	2060W020	Weldment, Trailer Tongue	1
47	2060A001	Dual Jockey Jack	1

Dual Jockey Jack Assembly

2060A001 DUAL JOCKEY JACK PARTS

BOM ID	Part No.	Description	Qty
50	Z12432	Snap Lock Pin, 3/8" x 2-1/2"	1
51	Z29202	Grease Fitting, 1/4NF	1
52	Z46203	E-Style Retaining Ring, 3/4"	2
53	Z71305	Hex Bolt, 3/8NC x 1/2"	1
54	Z71330	Hex Bolt, 3/8NC x 3"	1
55	Z72231	Hex Lock Nut, 3/8NC	1
56	Z91311	4.10-6NHS 2PR 290lbs Sawtooth x 3/4"	2
57	Z91515	Trailer Jack, Side Wind x 2000lbs No Foot	1
58	2060W022	Weldment, Jockey Pivot Foot	1
59	2060W023	Weldment, Dual Jockey Axle	1
60	2060L008	Washer, 3/8" Extra Wide	1

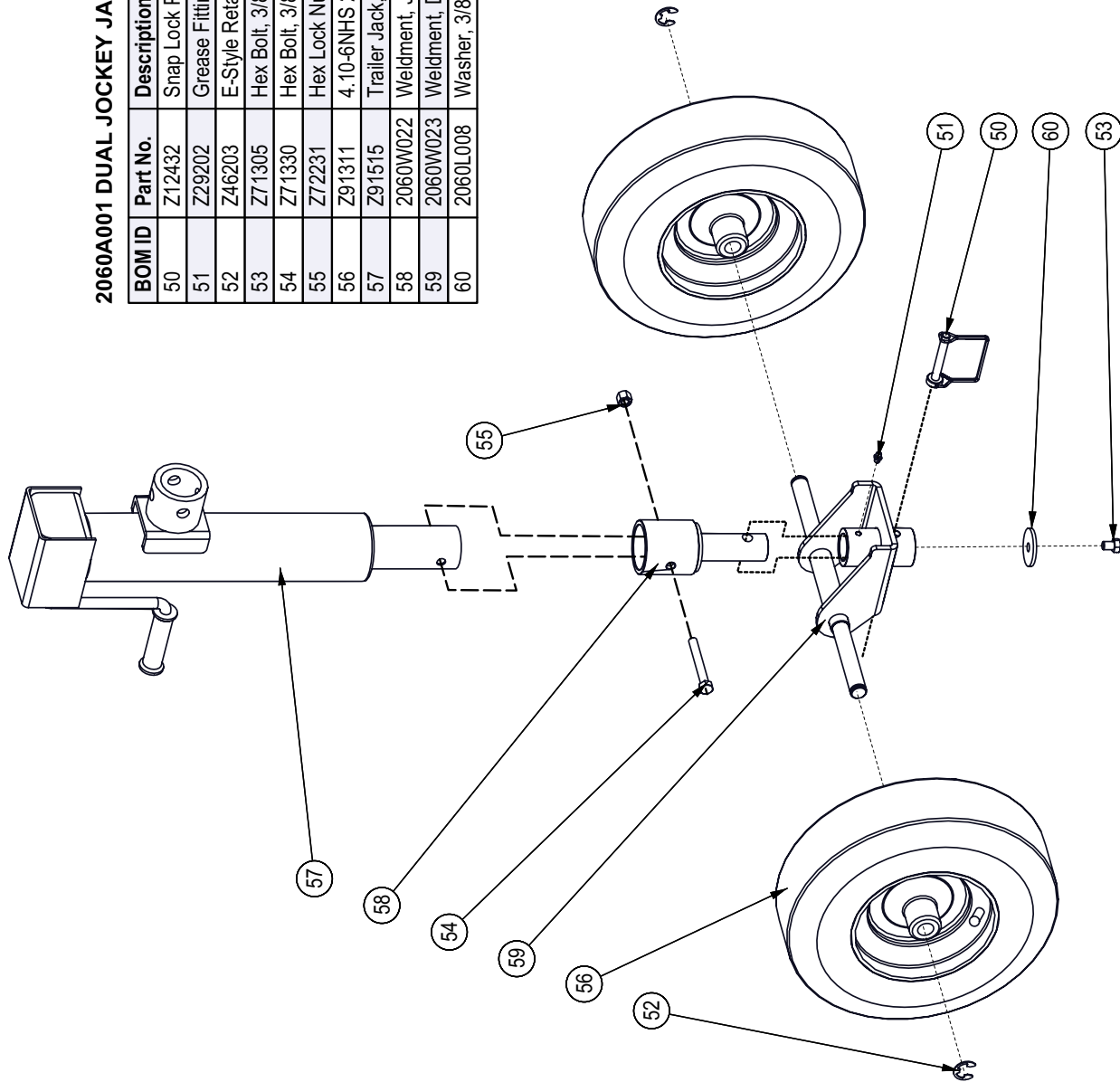



2058A802 SLIDING WEDGE PARTS

BOM ID	Part No.	Description	Qty
1	2058W803	Wedge Weldment for WX950	1
2	2014S414	Plate, Sliding Wedge Capture	1
3	Z71537	Hex Bolt, 1/2NC x 3-3/4"	1
4	Z71576G8	Hex Bolt, 1/2NF x 1-1/2" G8	4
5	Z72251	Hex Lock Nut, 1/2NC	1

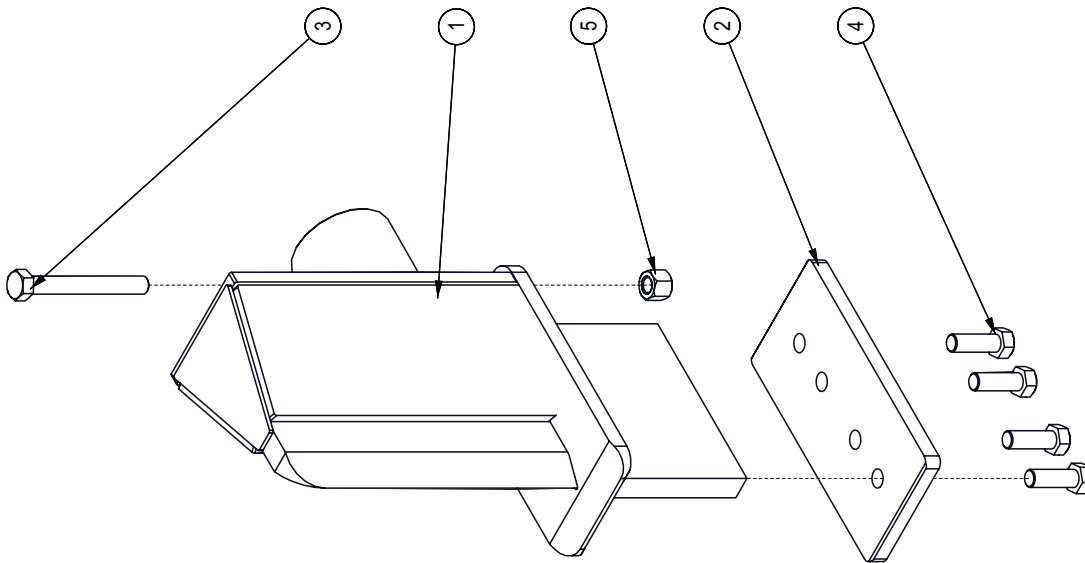

Sliding Wedge Assembly

**Hub Assembly**

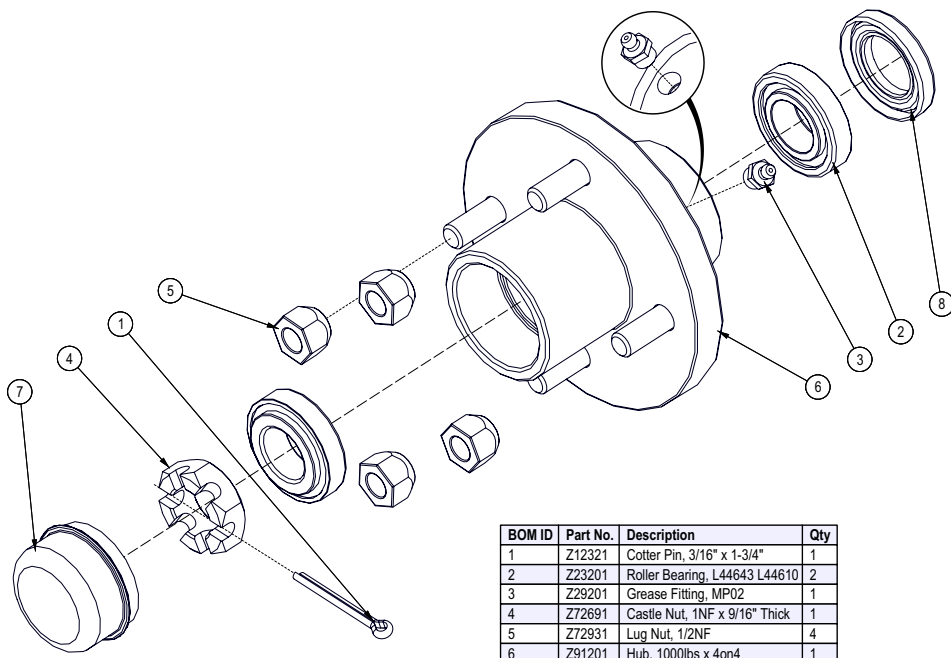

BOM ID	Part No.	Description	Qty
1	Z12321	Cotter Pin, 3/16" x 1-3/4"	1
2	Z23201	Roller Bearing, L44643 L44610	2
3	Z29201	Grease Fitting, MP02	1
4	Z72691	Castle Nut, 1NF x 9/16" Thick	1
5	Z72931	Lug Nut, 1/2NF	4
6	Z91201	Hub, 1000lbs x 4on4	1
7	Z91801	Dust Cap, 1.98 Bore	1
8	Z28301	Double Lip Seal, 1-1/4"	1

**Engine and Hydraulics Assembly**

BOM ID	Part No.	Description	Qty
1	Z46404	Shaft Coupling, L095 x 1"	1
2	Z46405	Spider, L095	1
3	Z46409	Shaft Coupling, L095 x 1/2"	1
4	Z46533	Key, 1/4" x 1/4" x 1"	1
5	Z46592	Woodruff Key, 1/8" x 1/2"	1
6	Z47135	Honda GX270UTQH6, Rope	1
7	Z51331	Elbow 90, MP x FPX 0808	1
8	Z53205	Two-Stage Pump, 16GPM	1
9	Z53802	Pump Mount, PM-9	1
10	Z71207	Hex Bolt, 5/16NC x 3/4"	4
11	Z71274	Hex Bolt, 5/16NF x 1"	2
12	Z71320	Hex Bolt, 3/8NC x 2"	4
13	Z72231	Hex Lock Nut, 3/8NC	4
14	Z71273	Hex Bolt, 5/16NF x 3/4"	2

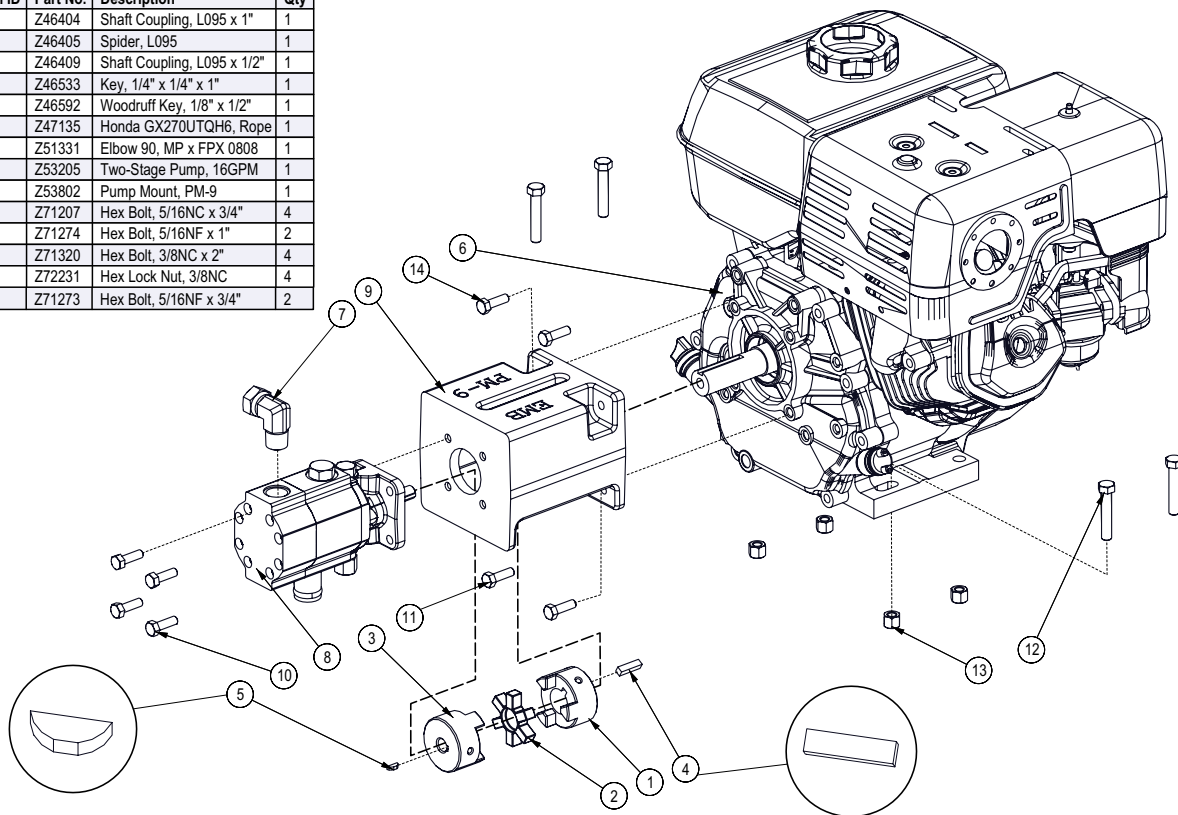

**Sliding Wedge Cylinder**

**Seal Kit #SLK-4525**

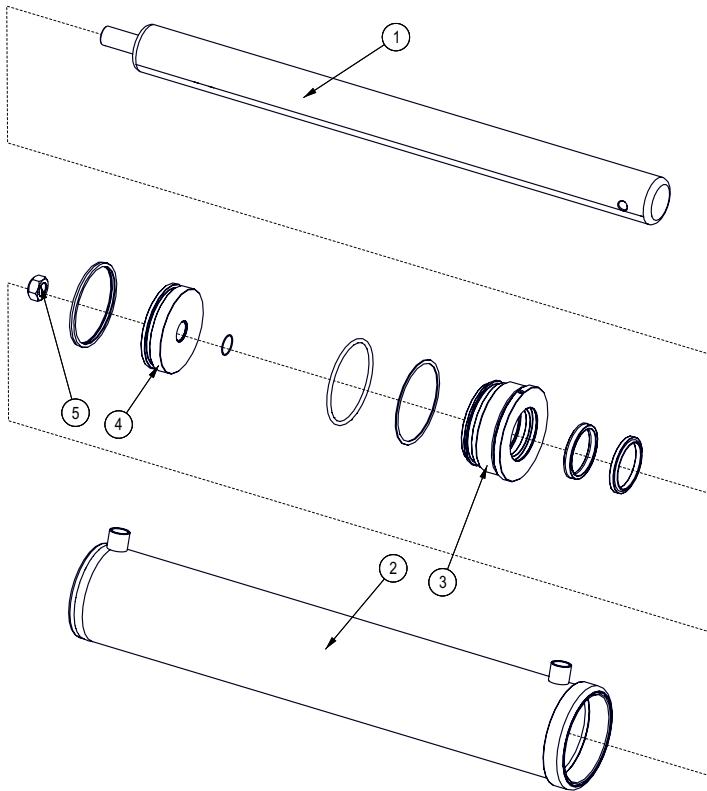

BOM ID	Part No.	Description	Qty
1	2055C5012	Rod, 2-1/2x 1	1
2	2055C5014	Barrel, 4-1/2"	1
3	G450-250S	Gland, 4-1/2" x 2-1/2"	1
4	P100-450SP	Piston, 4-1/2" Bore	1
5	Z72276	Hex Top-lock Nut, 3/4NF	1

**Lift Shelf Cylinder**

**Seal Kit #SLK-3515**

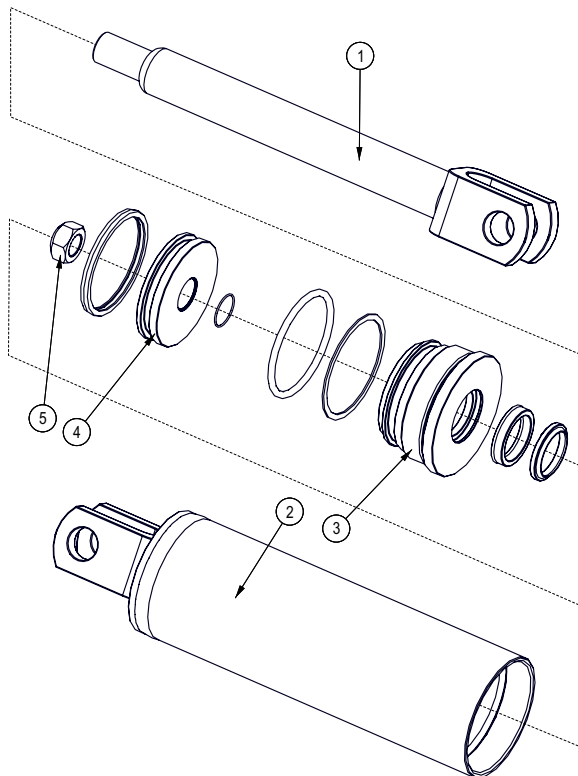

BOM ID	Part No.	Description	Qty
1	2058C8013	Rod, 1-1/2 x1	1
2	2058C8014	Barrel, 3-1/2"	1
3	G350-150S	Gland, 3-1/2" x 1-1/2"	1
4	P100-350SP	Piston, 3-1/2" Bore	1
5	Z72276	Hex Top-lock Nut, 3/4NF	1

**Valve Assembly**

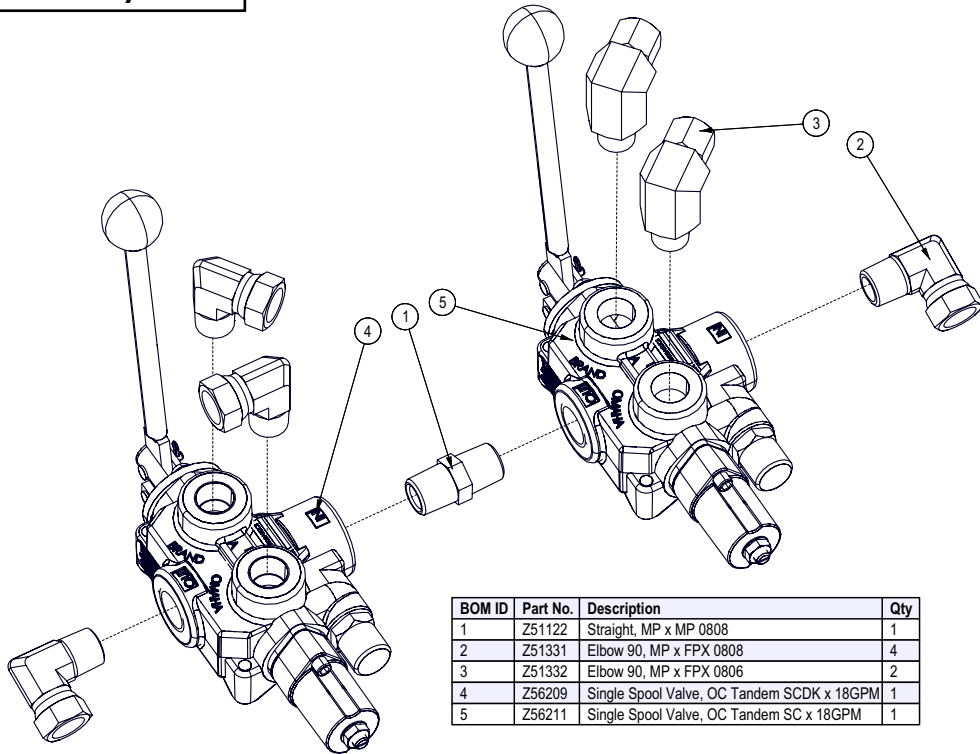

BOM ID	Part No.	Description	Qty
1	Z51122	Straight, MP x MP 0808	1
2	Z51331	Elbow 90, MP x FPX 0808	4
3	Z51332	Elbow 90, MP x FPX 0806	2
4	Z56209	Single Spool Valve, OC Tandem SCDK x 18GPM	1
5	Z56211	Single Spool Valve, OC Tandem SC x 18GPM	1

**Z56209 Service Kits**

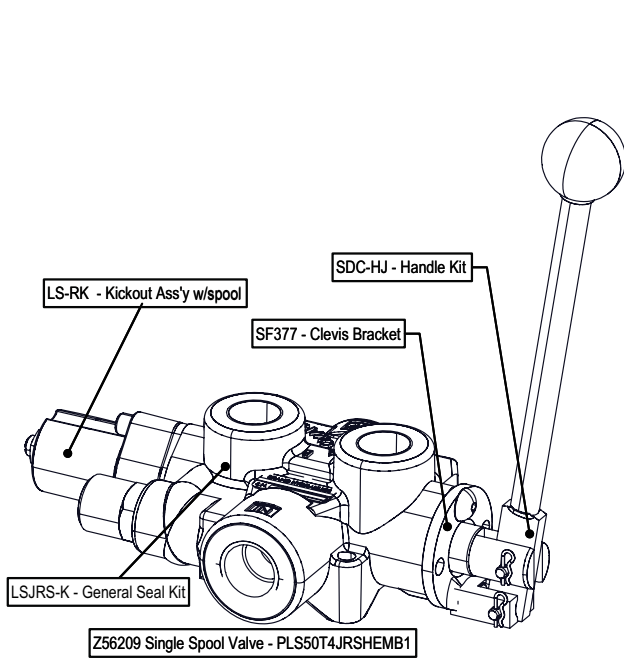

**Z56211 Service Kits**

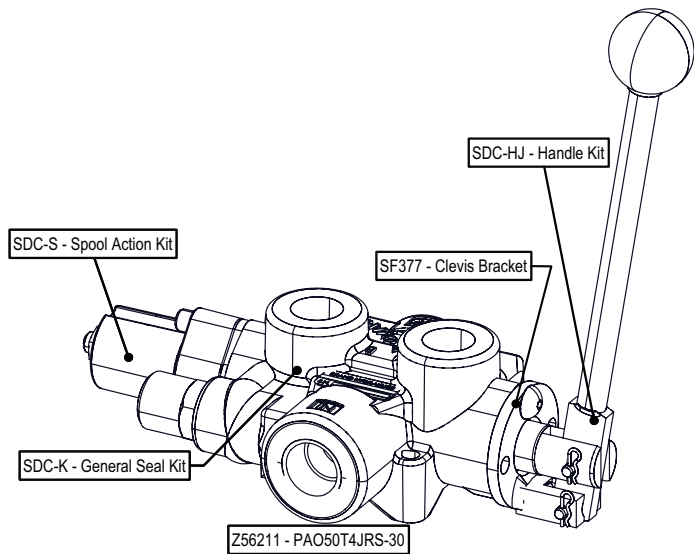

**Hydraulic Schematic**

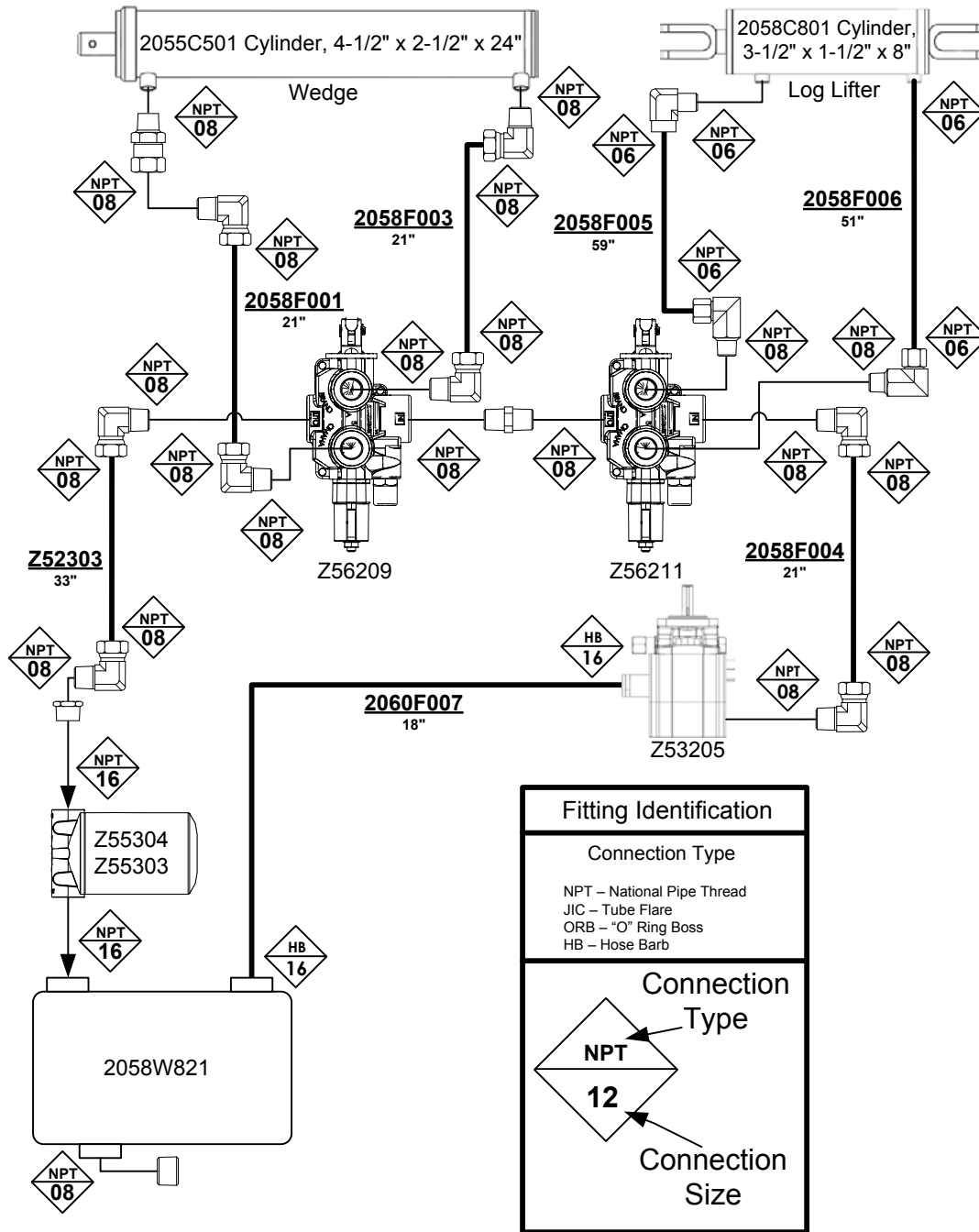

**Hydraulic Hose List**

PART NUMBER	DESCRIPTION	QTY
2058F001	1/2" Hose, MP08 x MP08 x 21"	1
2058F002	1/2" Hose, MP08 x MP08 x 24"	1
2058F003	1/2" Hose, MP08 x MP08 x 21"	1
2058F004	1/2" Hose, MP08 x MP08 x 21"	1
2058F005	3/8" Hose, MP06 x MP06 x 59"	1
2058F006	3/8" Hose, MP06 x MP06 x 51"	1
2060F007	Suction Hose, 1" x 18"	1

Label Layout



Z94056 x 2

WX950 Z94694 x 2



Z94239 x 1



Z94426 x 2

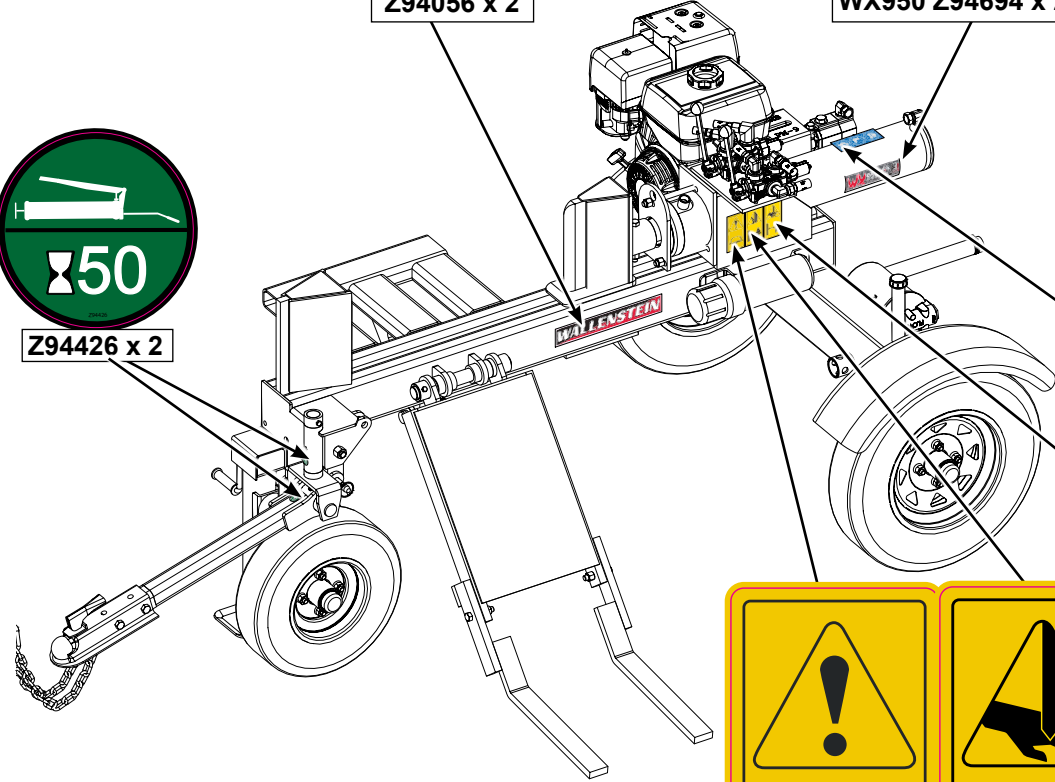

Z94119 x 2

Z94124 x 2

Z94123 x 2



Z94428 x 2

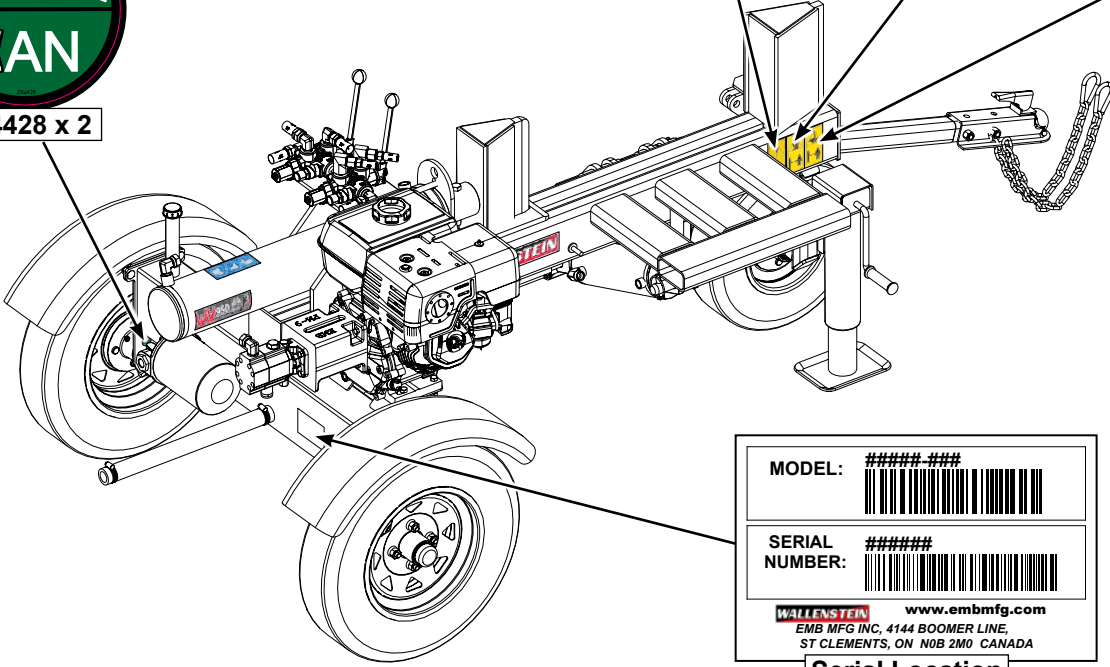

MODEL: #####

SERIAL NUMBER: #####

WALLENSTEIN www.embmfg.com  
 EMB MFG INC, 4144 BOOMER LINE,  
 ST CLEMENTS, ON N0B 2M0 CANADA

Serial Location

**Accessories**

Call your dealer for pricing and availability

**#4130 - 4 Way Wedge**

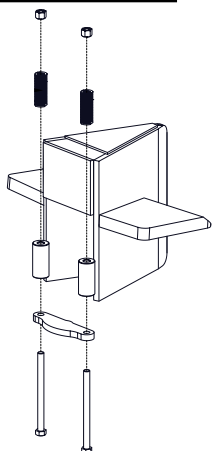

Boost your productivity and make quick work out of logs by splitting four pieces at once. This is an ideal way to save time.



**#Z97043  
TRAILER WOODSPLITTER  
OPERATOR'S MANUAL**

Available as a download at  
[www.wallensteinequipment.com](http://www.wallensteinequipment.com)