

# PARTS MANUAL

---

Serial Number 2E9US1114MS045083 to 2E9US1110PS045232, and 1100000 to 1101347

## WP845 Firewood Processor

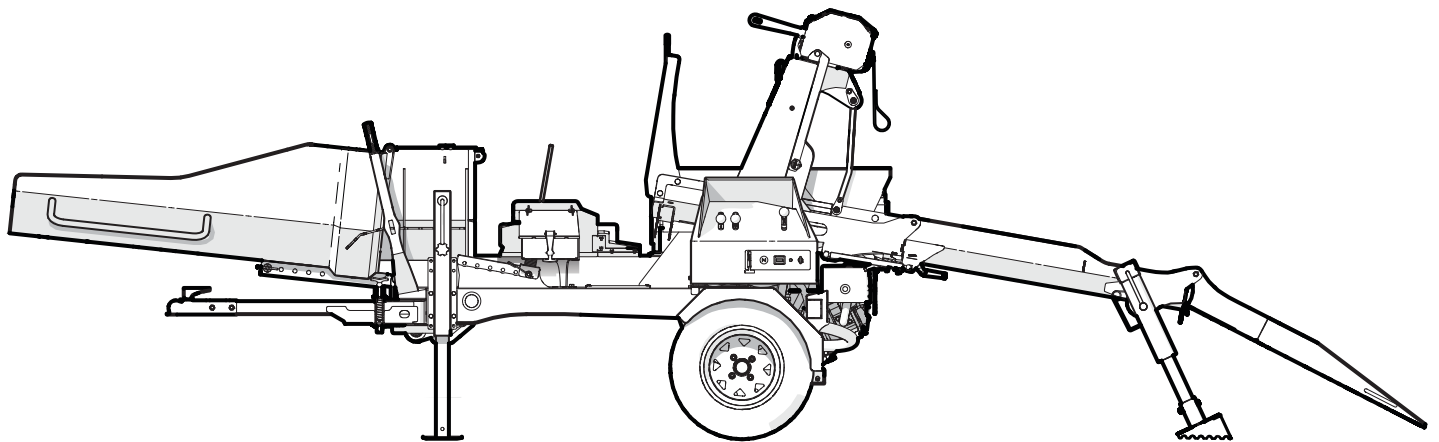

## Foreword

This Wallenstein parts manual is prepared to assist customers in ordering quality OEM replacement parts.

Regular maintenance combined with replacing old, worn or broken parts with the correct OEM parts is essential in prolonging the life of your Wallenstein product. Refer to this manual to identify replacement parts.

To order parts, contact your Wallenstein dealer or distributor. Have the product model and serial number handy.

If your dealer is no longer available, please go to [WallensteinEquipment.com](http://WallensteinEquipment.com). At the bottom of the page, select Dealer Locator.

All information contained in this parts manual is current as per the revision date at the bottom of the page. Wallenstein reserves the right to change product specifications at any time without notice.

If your product specifications differ from those contained in this manual, contact Wallenstein for current information.

Reproduction of information in this parts manual is prohibited without prior written permission from Wallenstein Equipment Inc.

Wallenstein Equipment Inc. • © 2022

### **WARNING!**

**For safety, operation, and maintenance information, see the Operator's Manual.**

**Maintenance should be performed by trained personnel only.**

### Serial Number Location

Always provide the model and serial number of your Wallenstein product when ordering parts or requesting service or other information. The serial number is on the product information plate as shown below.

**Record your product information here for future reference.**

**Model** \_\_\_\_\_

**Serial Number** \_\_\_\_\_

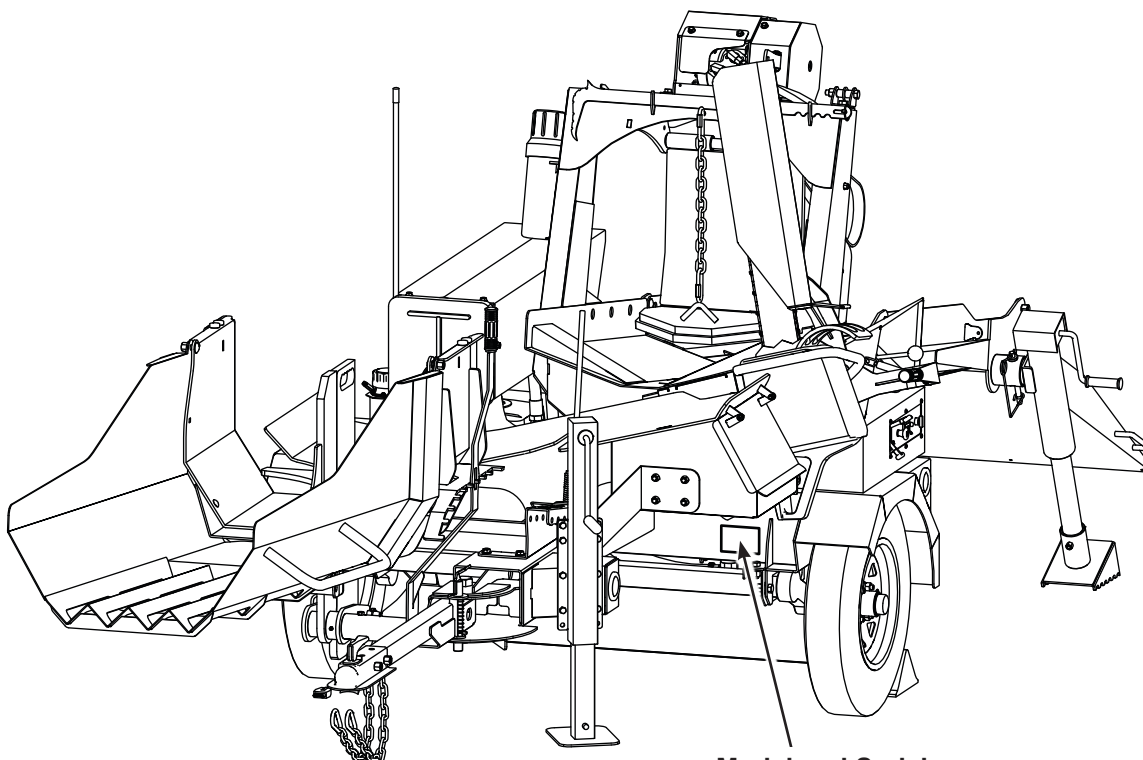

**Model and Serial Number Location**

[www.wallensteinequipment.com](http://www.wallensteinequipment.com)

## Contents

<b>Splitter Chute Assembly.....</b>	<b>4</b>
<b>Lead In Chute Assembly .....</b>	<b>5</b>
<b>Log Hold Down Assembly.....</b>	<b>6</b>
<b>Splitter Main Frame Assembly.....</b>	<b>7</b>
<b>Log Chute Assembly .....</b>	<b>8</b>
<b>Running Gear .....</b>	<b>9</b>
<b>Hydraulic Splitter Assembly .....</b>	<b>10</b>
<b>Engine and Pump Assembly.....</b>	<b>11</b>
<b>Hydraulic Winch.....</b>	<b>12</b>
<b>Winch Drum.....</b>	<b>13</b>
<b>Panel Assembly.....</b>	<b>14</b>
<b>Tool Box Lid.....</b>	<b>15</b>
<b>Cylinder.....</b>	<b>16</b>
<b>Hub Assembly .....</b>	<b>16</b>
<b>Lights and Harness.....</b>	<b>17</b>
<b>Valve Assembly .....</b>	<b>18</b>
<b>Hydraulic Circuit .....</b>	<b>19</b>
<b>Pivoting Chan Saw Holder .....</b>	<b>20</b>
<b>Decal Layout.....</b>	<b>21</b>
<b>Control Panel Decals .....</b>	<b>24</b>
<b>Accessories.....</b>	<b>25</b>
<b>Common Bolt Torque Values .....</b>	<b>26</b>
<b>Hydraulic Fitting Torque Values .....</b>	<b>27</b>
<b>Wheel Lug Torque Values.....</b>	<b>27</b>
<b>Hydraulic Fitting Torque Values .....</b>	<b>28</b>

**Splitter Chute Assembly**

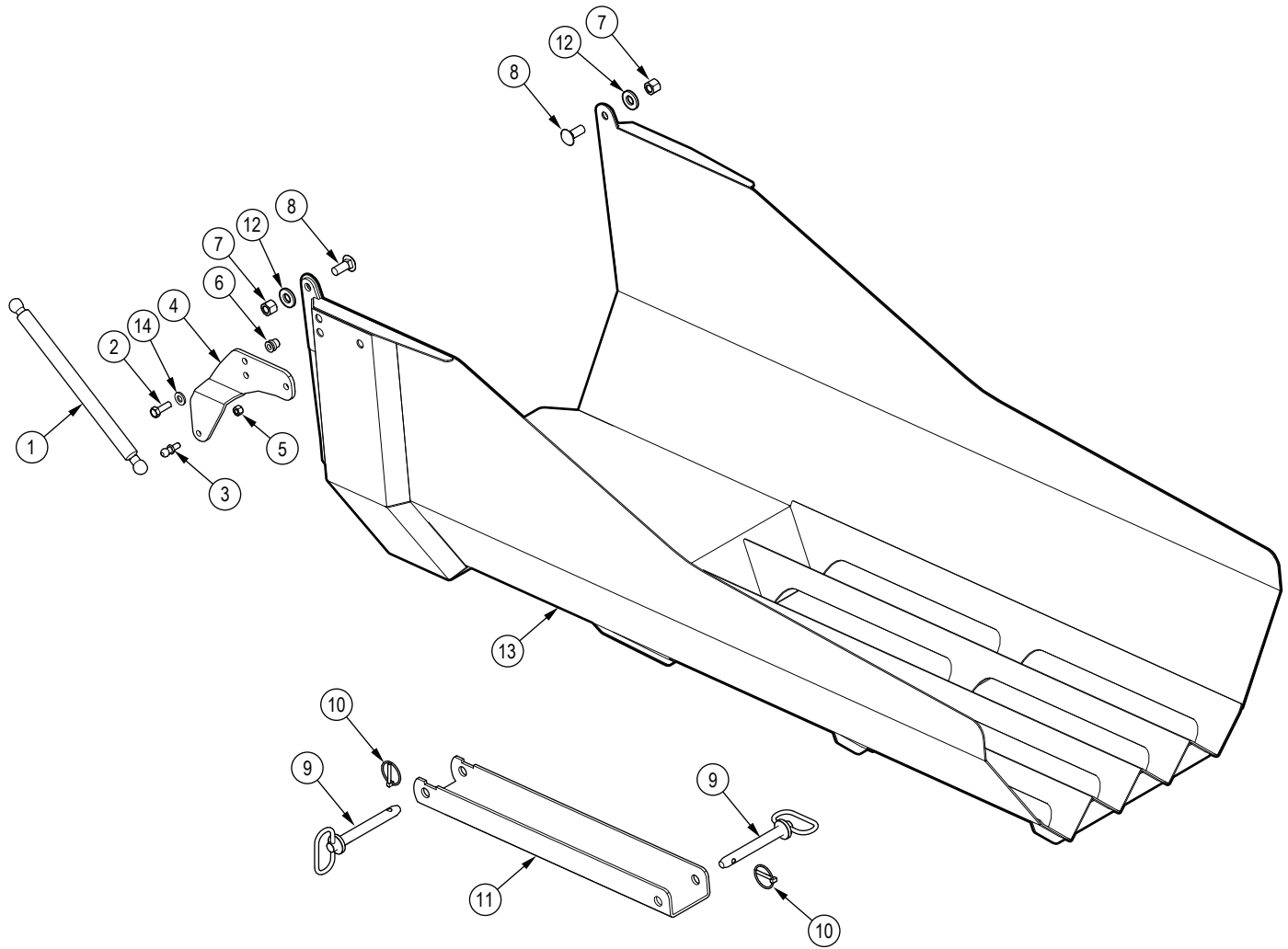

Item Number	Part No.	Description	Qty
1	Z34216	Gas Spring, 10mm OD	1
2	Z71212	Hex Bolt, 5/16NC x 1-1/4	3
3	Z34204	Ball Stud, 13mm x 5/16NC	2
4	2071L188	Plate, Spring Mount	1
5	Z72221	Hex Lock Nut, 5/16NC	2
6	Z72956	Rivet Nut, 5/16NC x 150	3
7	Z72251	Hex Lock Nut, 1/2NC	2

Item Number	Part No.	Description	Qty
8	Z76251	Carriage Bolt, 1/2NC x 1-1/2"	2
9	Z11232	Hitch Pin, 5/8" x 4-1/4"	2
10	Z12110	Lynch Pin, 3/16"	2
11	2071L164	Channel, Chute Adjust	1
12	Z73151G8	SAE Washer, 1/2" Grade 8	2
13	2251W044	Splitter Chute	1
14	Z73122G8	SAE Washer, 5/16" Grade 8	3

**Lead In Chute Assembly**

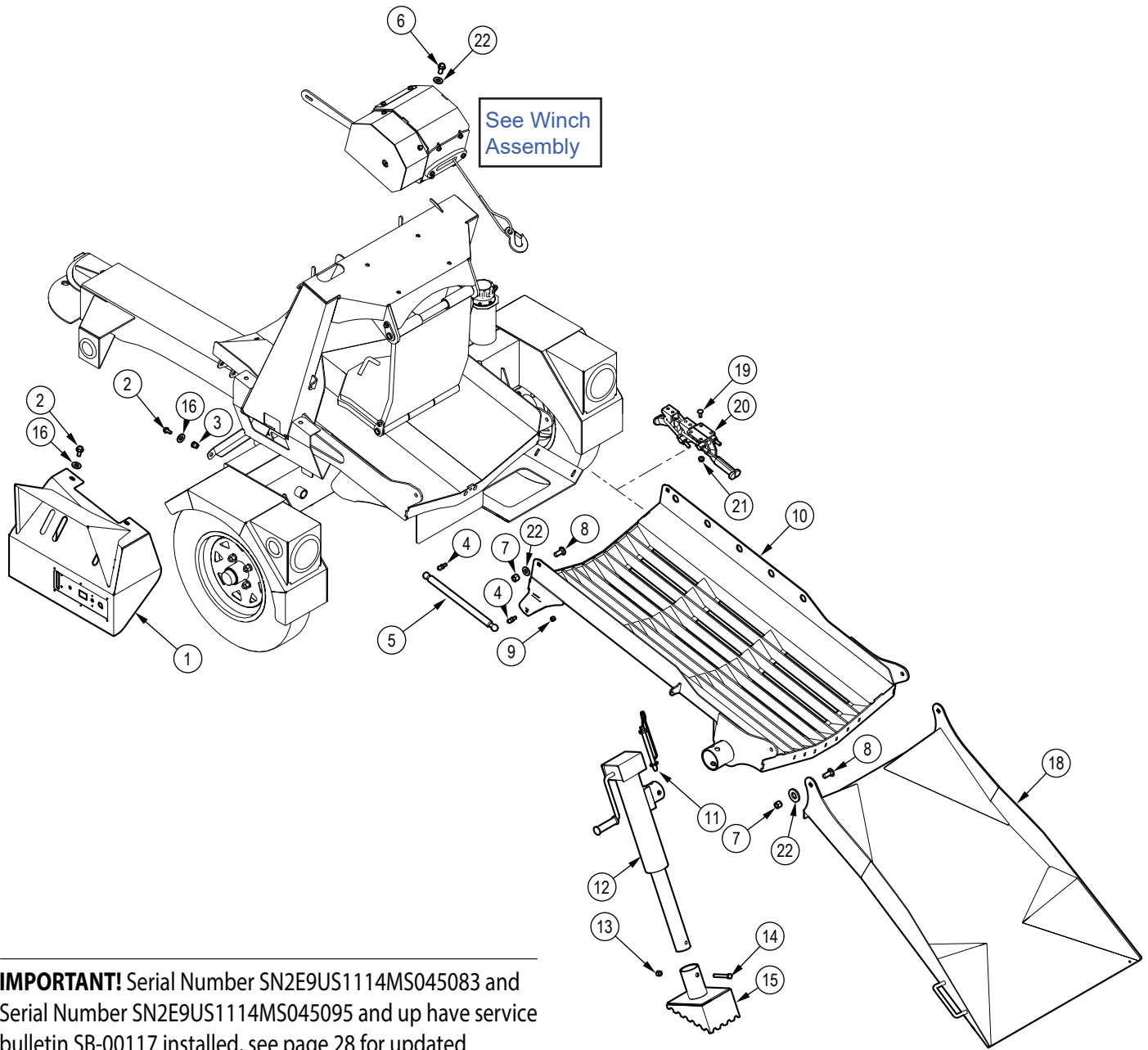

**IMPORTANT!** Serial Number SN2E9US1114MS045083 and Serial Number SN2E9US1114MS045095 and up have service bulletin SB-00117 installed, see page 28 for updated replacement parts.

Item No.	Part No.	Description	Qty
1	2251W043	Valve Cover	1
2	Z71212	Hex Bolt, 5/16NC x 1-1/4"	3
3	Z72956	Rivet Nut, 5/16NC x 150	3
4	Z34204	Ball Stud, 13mm x 5/16NC	4
5	Z34216	Gas Spring, 10mm	2
6	Z71515	Hex Bolt, 1/2NC x 1-1/2"	4
7	Z72251	Hex Lock Nut, 1/2NC	2
8	Z76259	Carriage Bolt, 1/2NC x 1-1/4"	4
9	Z72221	Hex Lock Nut, 5/16NC	2
10	2251W046	Chute, Log Loader Bottom	1

Item No.	Part No.	Description	Qty
11	Z12441	Snap Lock Pin, 1/2" x 4-1/2"	2
12	Z91515	Trailer Jack, Side Wind x 2000lbs No Foot	2
13	Z72231	Hex Lock Nut, 3/8NC	2
14	Z71330	Hex Bolt, 3/8NC x 3"	2
15	2071L204	Foot, Jack	2
16	Z73122G8	SAE Washer, 5/16" Grade 8	14
18	2251W055	Chute, Lead In	1
19	Z76211	Carriage Bolt, 1/4NC x 3/4"	12
20	Z19511	Handle Clamp, Latch Type x 2-Piece	2
21	Z72511	Serrated Flange Locknut, 1/4NC	12
22	Z73151G8	SAE Washer, 1/2" Grade 8	18

**Log Hold Down Assembly**

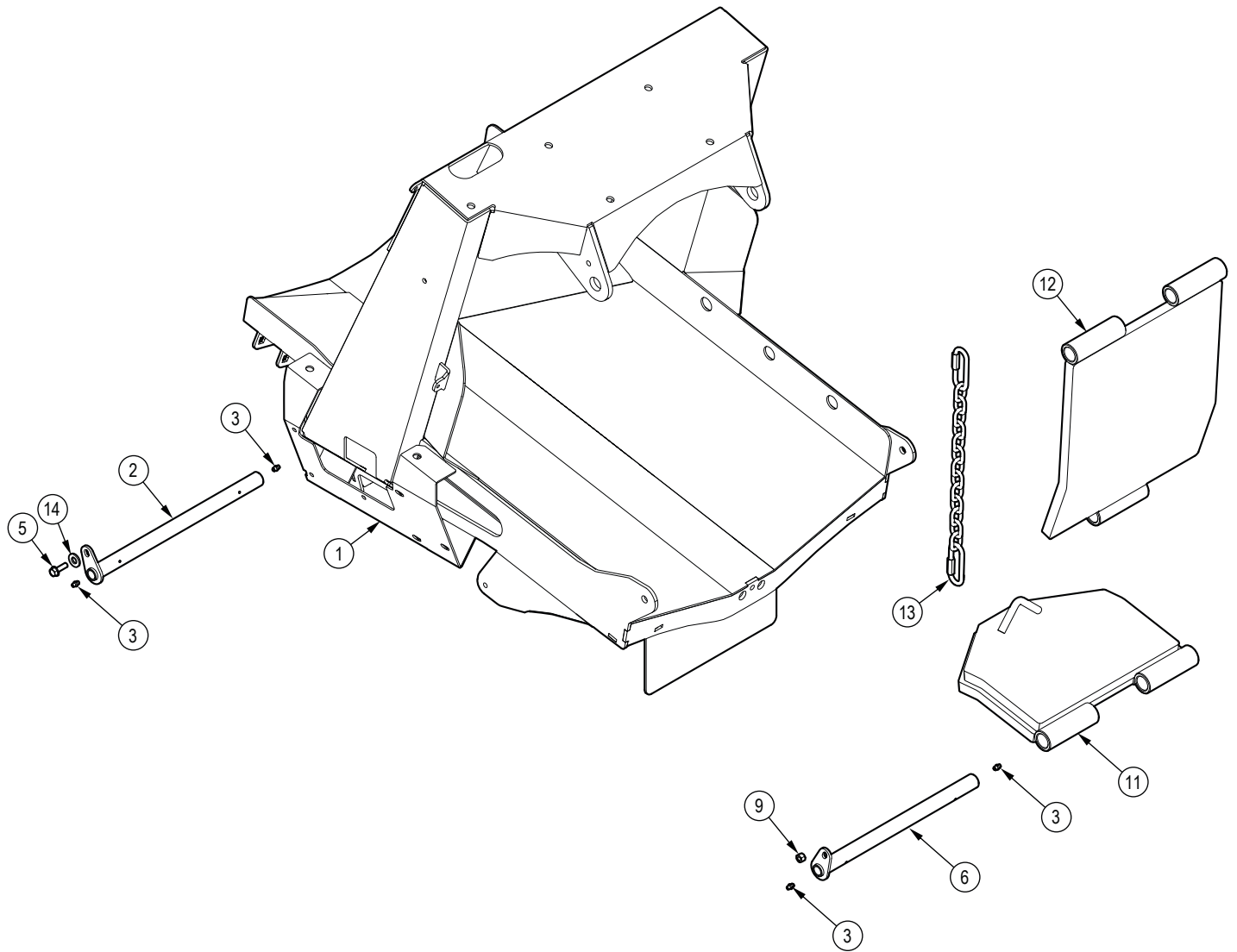

Item No.	Part No.	Description	Qty
1	2210W045	Chute, Log	1
2	2071W112	Pin, Log Hold Down	1
3	Z29202	Grease Fitting, 1/4NF	5
5	Z71212	Hex Bolt, 5/16NC x 1-1/4"	1
6	2071W136	Pin, Log Hold Down	1

Item No.	Part No.	Description	Qty
9	Z72223	Hex Lock Nut, 5/16NC	1
11	2071W102	Hold Down Bottom	1
12	2071W110	Plate, Hold Down Top	1
13	Z92311	Chain, 1/4" x 21" with Two Quicklinks	1
14	Z73122G8	SAE Washer, 5/16" Grade 8	2

**Splitter Main Frame Assembly**

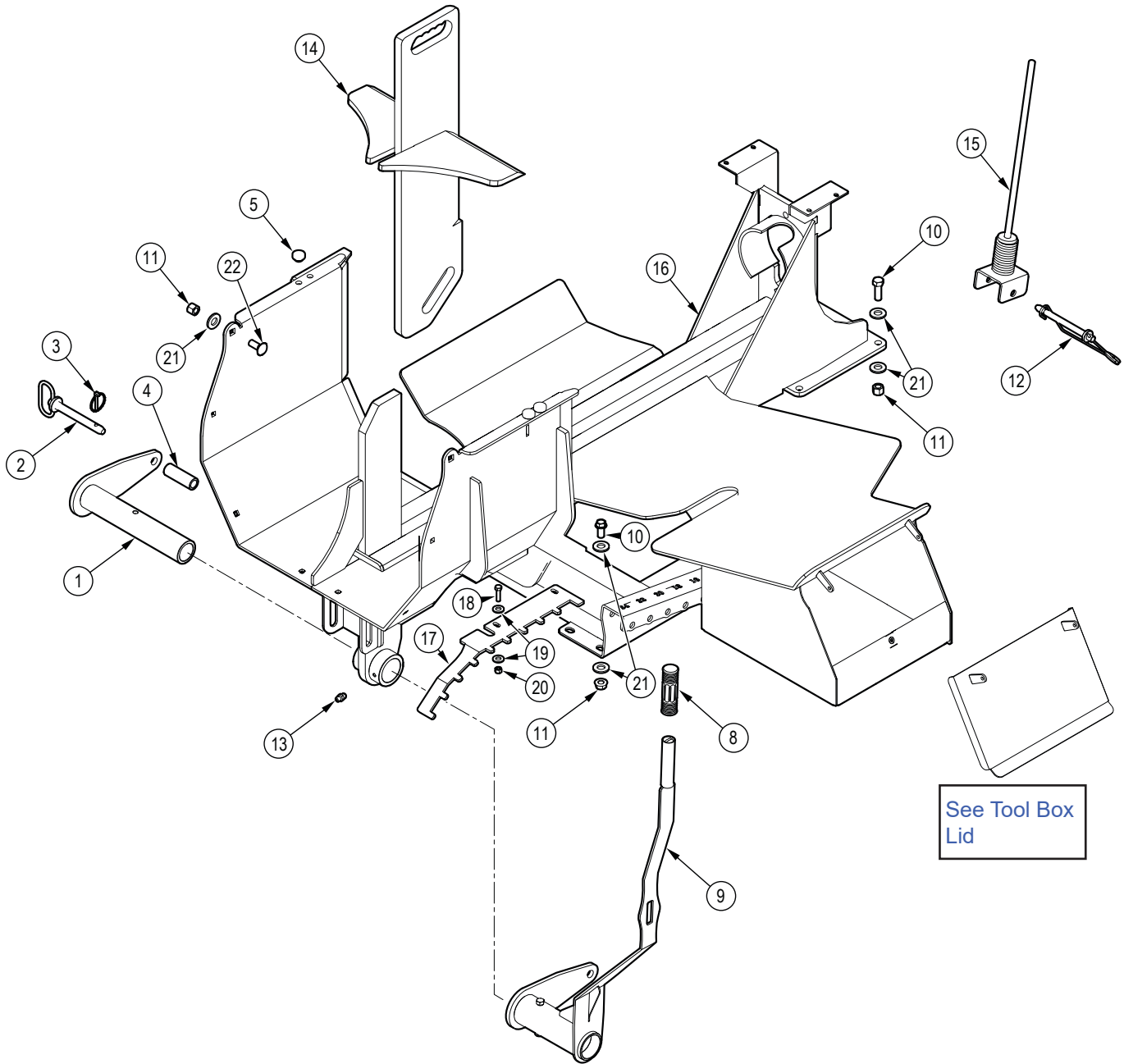

See Tool Box Lid

Item No.	Part No.	Description	Qty
1	2251W049	Pipe, Wedge Position Handle	1
2	Z11232	Hitch Pin, 5/8" x 4-1/4"	1
3	Z12110	Lynch Pin, 3/16"	1
4	2071M123	Roller Wedge Lift	1
5	Z19909	Rubber Bumper, 7/16" x 1"	4
8	Z19321	Handle Grip, 1"	1
9	2251W048	Wedge Position Handle	1
10	Z71515	Hex Bolt, 1/2NC x 1-1/2"	4
11	Z72251	Hex Lock Nut, 1/2NC	8
12	Z12441	Snap Lock Pin, 1/2" x 4-1/2"	1

Item No.	Part No.	Description	Qty
13	Z29202	Grease Fitting, 1/4NF	1
14	2071W532	Wedge 4 Way	1
15	2071W190	Rod Stop Whip	1
16	2251W057	Main Frame	1
17	2251W058	Rack, Wedge Lever	1
18	Z71212	Hex Bolt, 5/16NC x 1-1/4"	2
19	Z73122G8	SAE Washer, 5/16" Grade 8	7
20	Z72221	Hex Lock Nut, 5/16NC	4
21	Z73151G8	SAE Washer, 1/2" Grade 8	20
22	Z76251	Carriage Bolt, 1/2NC x 1-1/2"	4

Log Chute Assembly

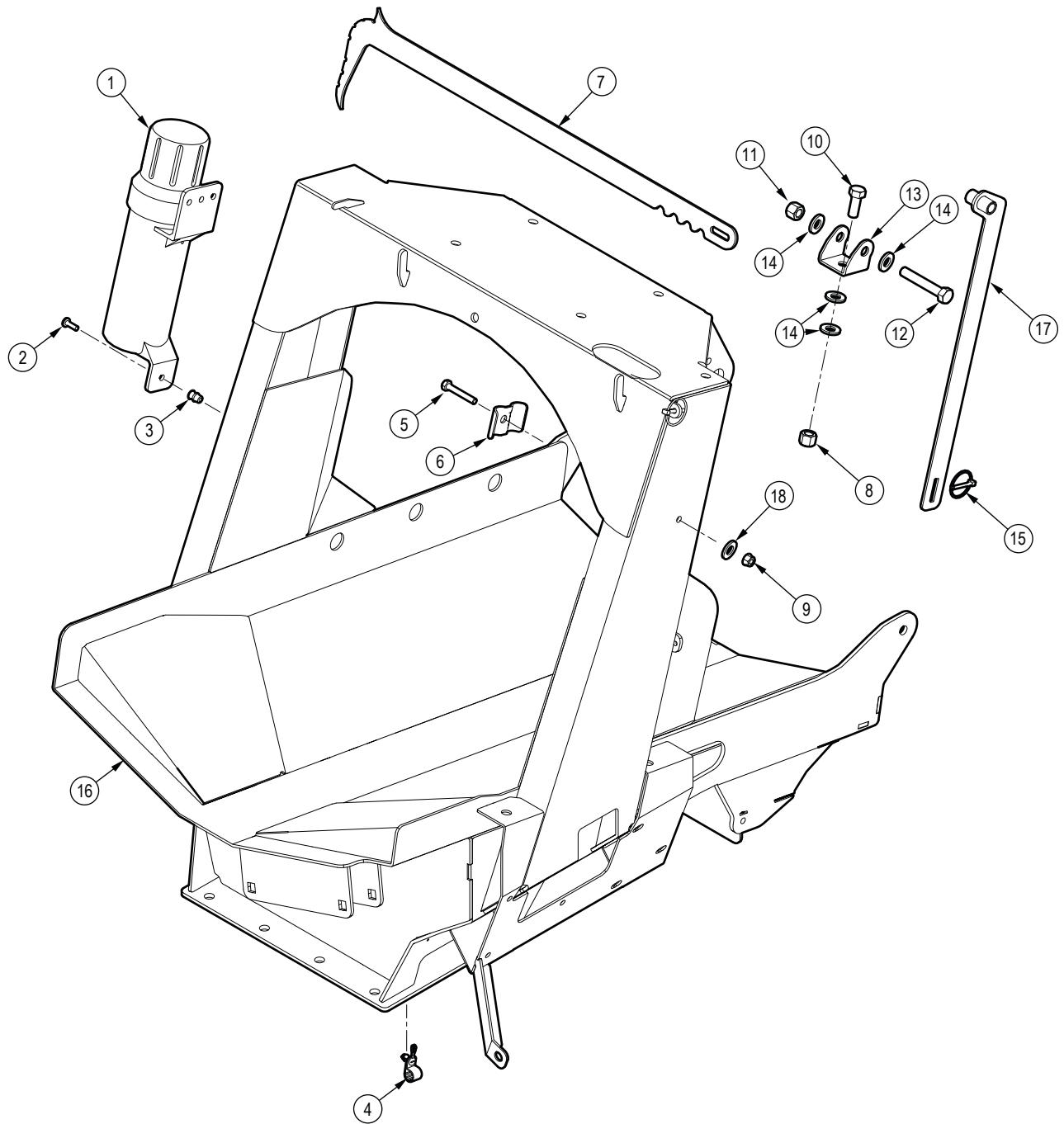

Item No.	Part No.	Description	Qty
1	Z96503	Manual Tube, 3-1/2" Short	1
2	Z78301	Machine Screw, 1/4NC x 3/4"	3
3	Z72962	Rivet Nut, 1/4NC x 260	3
4	Z62828	Cable Clamp, P-Type Push In 1/2"	2
5	Z71215	Hex Bolt, 5/16NC x 1 1/2"	1
6	2250L286	Hose Clamp, 2 x 3/8"	1
7	2250L223	Hookaroon, 30"	1
8	Z72251	Hex Lock Nut, 1/2NC	2
9	Z72221	Hex Lock Nut, 5/16NC	1

Item No.	Part No.	Description	Qty
10	Z71515	Hex Bolt, 1/2NC x 1-1/2"	1
12	Z71535	Hex Bolt, 1/2NC x 3 1/2"	1
13	2071L123	Clevis, Latch Mount	1
14	Z73151G8	SAE Washer, 1/2" Grade 8	4
15	Z12110	Lynch Pin, 3/16"	1
16	2251W054	Chute, Log	1
17	2071W121	Latch, Bottom Chute	1
18	Z73122G8	SAE Washer, 5/16" Grade 8	1



Running Gear

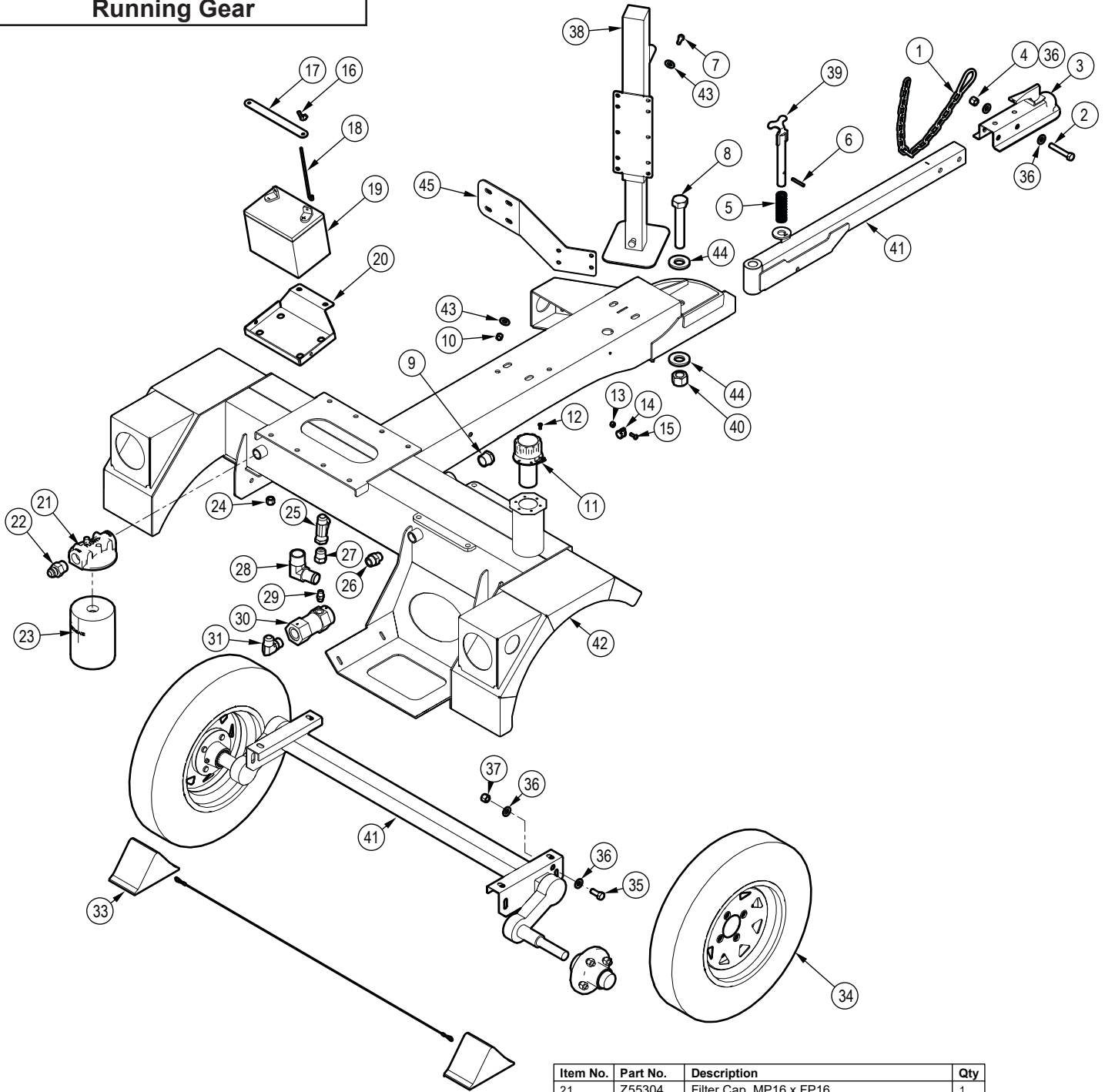

Item No.	Part No.	Description	Qty
1	Z92303	Safety Chain, 1/4" x 2ft with Snap	2
2	Z71535	Hex Bolt, 1/2NC x 3 1/2"	2
3	Z91614	Hitch Coupler, 2" Ball x 2" x 3500lbs	1
4	Z72251	Hex Lock Nut, 1/2NC	8
5	Z32307	Comp Spring, 1.100" OD x 3-1/2" x 0.080"	1
6	Z14172	Roll Pin, 1/4" x 1-3/4"	1
7	Z71310	Hex Bolt, 3/8NC x 1"	8
8	Z71919	Hex Bolt, 1NC x 6"	1
9	Z55901	Site Glass, MP16	1
10	Z72231	Hex Lock Nut, 3/8NC	8
11	Z55403	Filler Breather Cap x 400um Locking	1
12	Z78303	Machine Screw, #10NF x 1/2"	6
13	Z72211	Hex Lock Nut, 1/4NC	1
14	Z62819	Rubberized Wire Clamp, 1/2"	2
15	Z78301	Machine Screw, 1/4NC x 3/4"	2
16	Z72921	Wing Nut, 1/4NC	2
17	Z93207	Hold-Down Strap, 1" x 8-1/2"	1
18	Z93202	J-Hook, 1/4" x 7"	2
19	Z93204	Battery, 325CCA	1
20	2251L021	Tray, Battery	1

Item No.	Part No.	Description	Qty
21	Z55304	Filter Cap, MP16 x FP16	1
22	Z514403	Straight, MJIC x MP 1216	1
23	Z55303	Particulate Filter, FP16	1
25	Z51597	Tee, MJIC x FJIC x MJIC 121212	1
26	Z51613	Straight, MORB x MP 1212	1
27	Z514905	Straight, FJIC x MJIC 0612	1
28	Z511812	Elbow 90, MHB x MP 2020	1
29	Z51929	Straight, MJIC x MORB 0606 x 0.047" Orifice	1
30	Z56408	Dump Valve	1
31	Z516501	Elbow 90, MJIC x MORB 1212	1
33	Z91903	Wheel Chock	1
34	Z91322	5.30-12 LRC USA Trail 4on4" (E-Marked)	1
35	Z71515	Hex Bolt, 1/2NC x 1-1/2"	6
36	Z73151G8	SAE Washer, 1/2" Grade 8	16
38	1082W503	Jack Weldment	1
39	2251W040	Lock Pin	1
40	Z72291	Hex Lock Nut, 1NC	1
41	2251W539	Weldment, Pivot Tongue	1
42	2251W051	Weldment, WP845 Tank Base	1
43	Z73131G8	SAE Washer, 3/8" Grade 8	16
44	Z73191G8	SAE Washer, 1" Grade 8	2
45	2251L148	Brace, Toolbox	1

**Hydraulic Splitter Assembly**

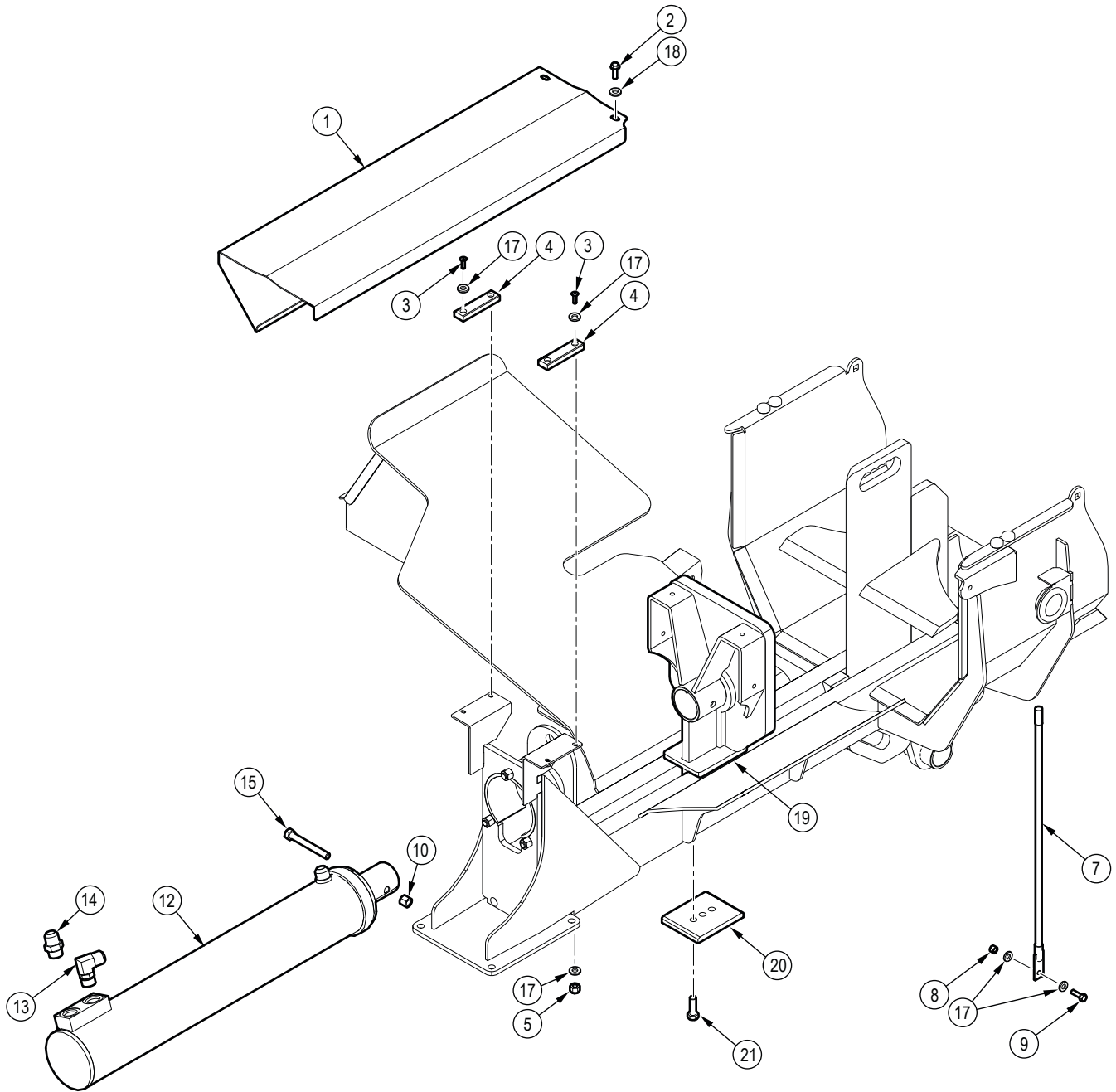

Item No.	Part No.	Description	Qty	Item No.	Part No.	Description	Qty
1	2251L009	Cover, Sliding	1	12	2251C001	Cylinder, 4-1/2 x 24 x 2-1/2	1
2	Z71212	Hex Bolt, 5/16NC x 1-1/4"	3	13	Z516501	Elbow 90, MJIC x MORB 1212	1
3	Z75214	FHCS, 1/4NC x 1-1/4"	4	14	Z516414	Straight, MJIC x MORB 1212	1
4	1022S208	Rotor Hood Slide	2	15	Z71540	Hex Bolt, 1/2NC x 4"	1
5	Z72221	Hex Lock Nut, 5/16NC	3	17	Z73111G8	SAE Washer, 1/4" Grade 8	6
7	Z19908	Blade Guide, 1/2" x 24"	1	18	Z73122G8	SAE Washer, 5/16" Grade 8	6
8	Z72211	Hex Lock Nut, 1/4NC	1	19	2251W038	Weldment, Hvy Push Block	1
9	Z71110	Hex Bolt, 1/4NC x 1"	1	20	2055S517	Cap, Push Block	1
10	Z72251	Hex Lock Nut, 1/2NC	1	21	Z71576G8	Hex Bolt, 1/2NF x 1-1/2" G8	3

**Engine and Pump Assembly**

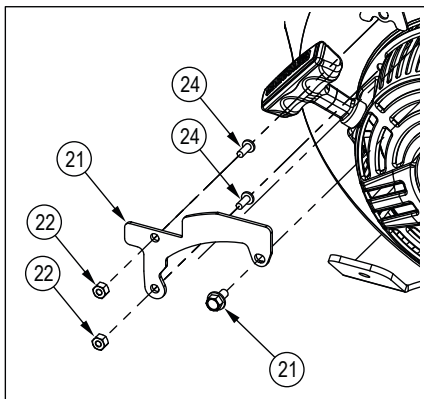
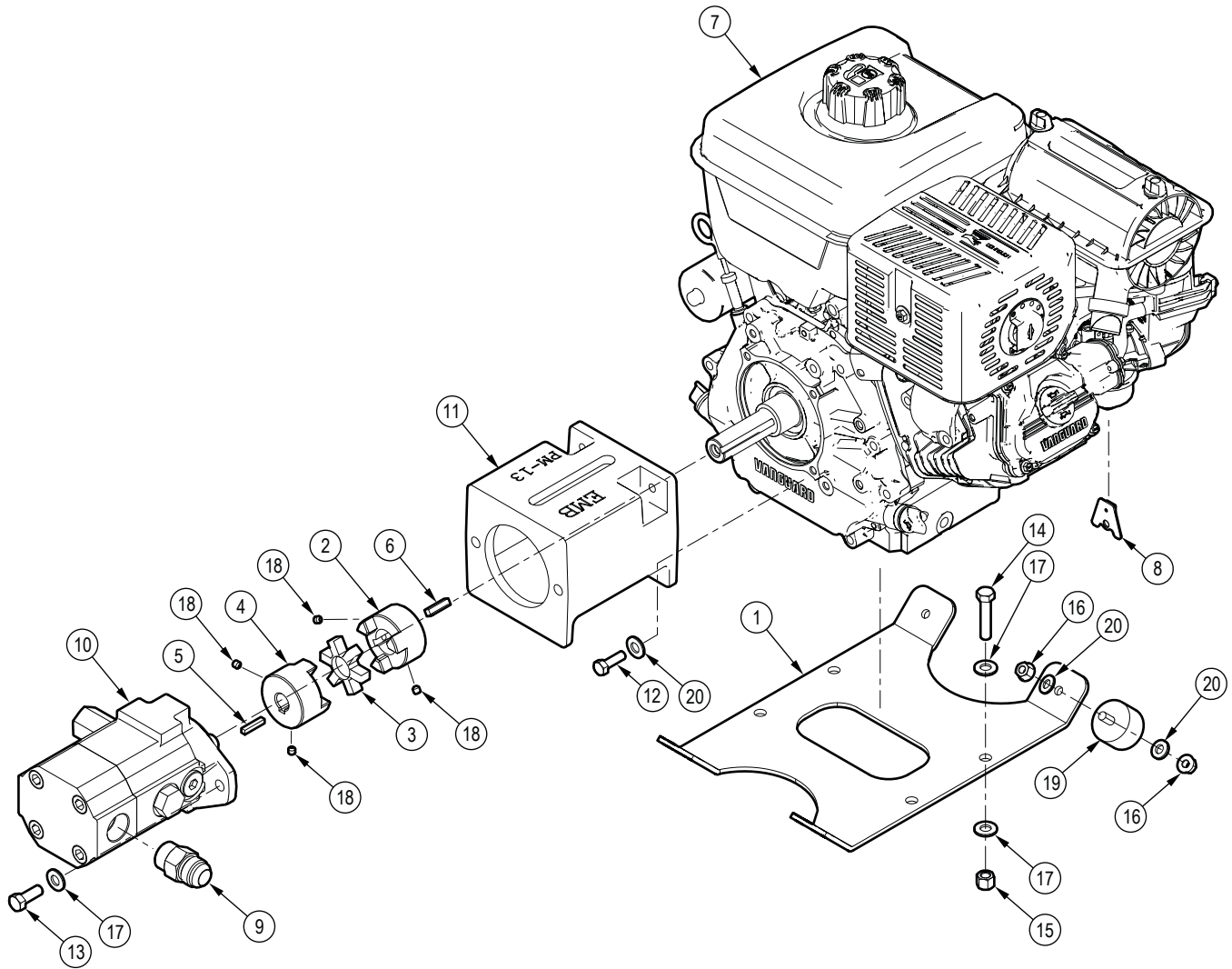

**Note:** SB-00122 only installed when necessary

Item No.	Part No.	Description	Qty
1	2251L019	Plate, Engine Mount	1
2	Z46404	Shaft Coupling, L095 x 1"	1
3	Z46405	Spider, L095	1
4	Z46419	Shaft Coupling, L095 x 5/8"	1
5	Z46522	Key, 3/16" x 3/16" x 1"	1
6	Z46533	Key, 1/4" x 1/4" x 1"	1
7	Z47764	Vanguard 400, Electric	1
8	Z47921	Casing Cable Clamp, Choke	1
9	Z514401	Straight, MJIC x MP 1212	1
10	Z53206	Two-Stage Pump, 22GPM	1

Item No.	Part No.	Description	Qty
11	Z53808	Pump Mount, PM-13	1
12	Z71274	Hex Bolt, 5/16NF x 1"	4
13	Z71310	Hex Bolt, 3/8NC x 1"	2
14	Z71317	Hex Bolt, 3/8NC x 1-3/4"	4
15	Z72231	Hex Lock Nut, 3/8NC	4
16	Z72221	Hex Lock Nut, 5/16NC	8
17	Z73131G8	SAE Washer, 3/8"	12
18	Z74111	Set Screw, 1/4NC x 1/4"	4
19	Z79933	Isolator, 1-9/16" Dia x 1" x 5/16NC	4
20	Z73122G8	SAE Washer, 5/16" Grade 8	12
21	2251L188	Choke Cable Extension Bracket	1
22	Z72204	Hex Lock Nut, #10NF	2
23	Z77631	Flange Bolt, M6 x1.0 x 12 mm	1
24	Z78303	Machine Screw, #10NF x 1/2"	2

Hydraulic Winch

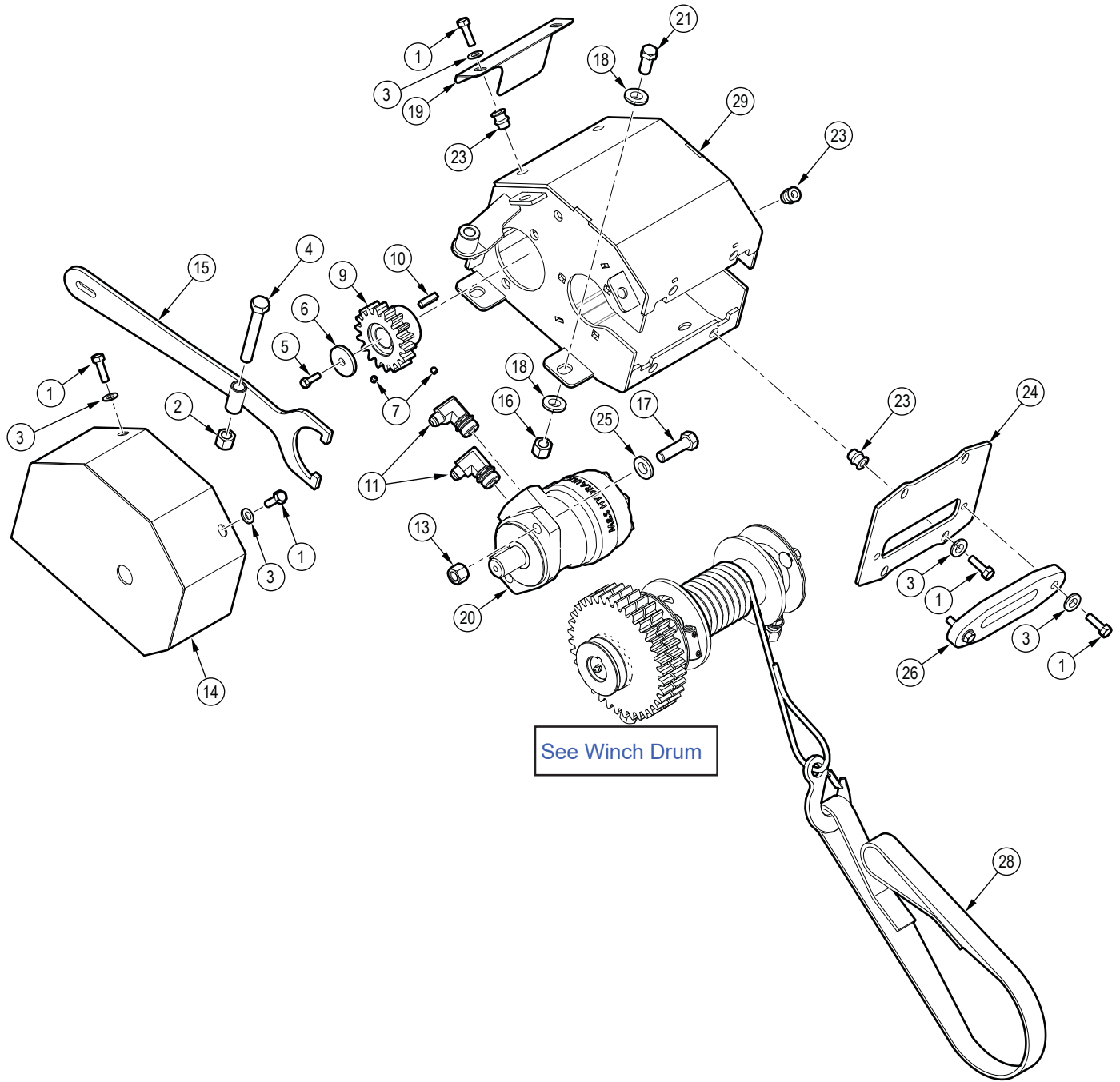

See Winch Drum

Item No.	Part No.	Description	Qty
1	Z71212	Hex Bolt, 5/16NC x 1-1/4"	11
2	Z72251	Hex Lock Nut, 1/2NC	11
3	Z73122G8	SAE Washer, 5/16" Grade 8	11
4	Z71535	Hex Bolt, 1/2NC x 3-1/2"	1
5	Z71107	Hex Bolt, 1/4NC x 3/4"	1
6	5081L114	Washer, Motor Shaft	1
7	Z74111	Set Screw, 1/4NC x 1/4"	2
9	5081M126	Drive Gear Hub	1
10	Z46533	Key, 1/4" x 1/4" x 1"	1
11	Z51656	Elbow 90, MJIC x MORB 0610	2
13	Z72251	Hex Lock Nut, 1/2NC	2
14	5081W111	Shield	1
15	5081W122	Handle, Winch Clutch	1

Item No.	Part No.	Description	Qty
16	Z73111G8	SAE Washer, 1/4" Grade 8	1
17	Z71517	Hex Bolt, 1/2NC x 1-3/4"	2
18	Z73151G8	SAE Washer, 1/2" Grade 8	10
19	5081L138	Guard	1
20	Z54109	Hydraulic Motor, 100CCR	1
21	Z71515	Hex Bolt, 1/2NC x 1-1/2"	4
23	Z72957	Rivet Nut, 5/16NC x 312	9
24	2251L071	Mount, Hawse Fairlead	1
26	2251M003	Synthetic Fairlead	1
28	Z92405	Winching Strap, 1" x 5ft	1
29	2251W018	Housing, Winch	1

Winch Drum

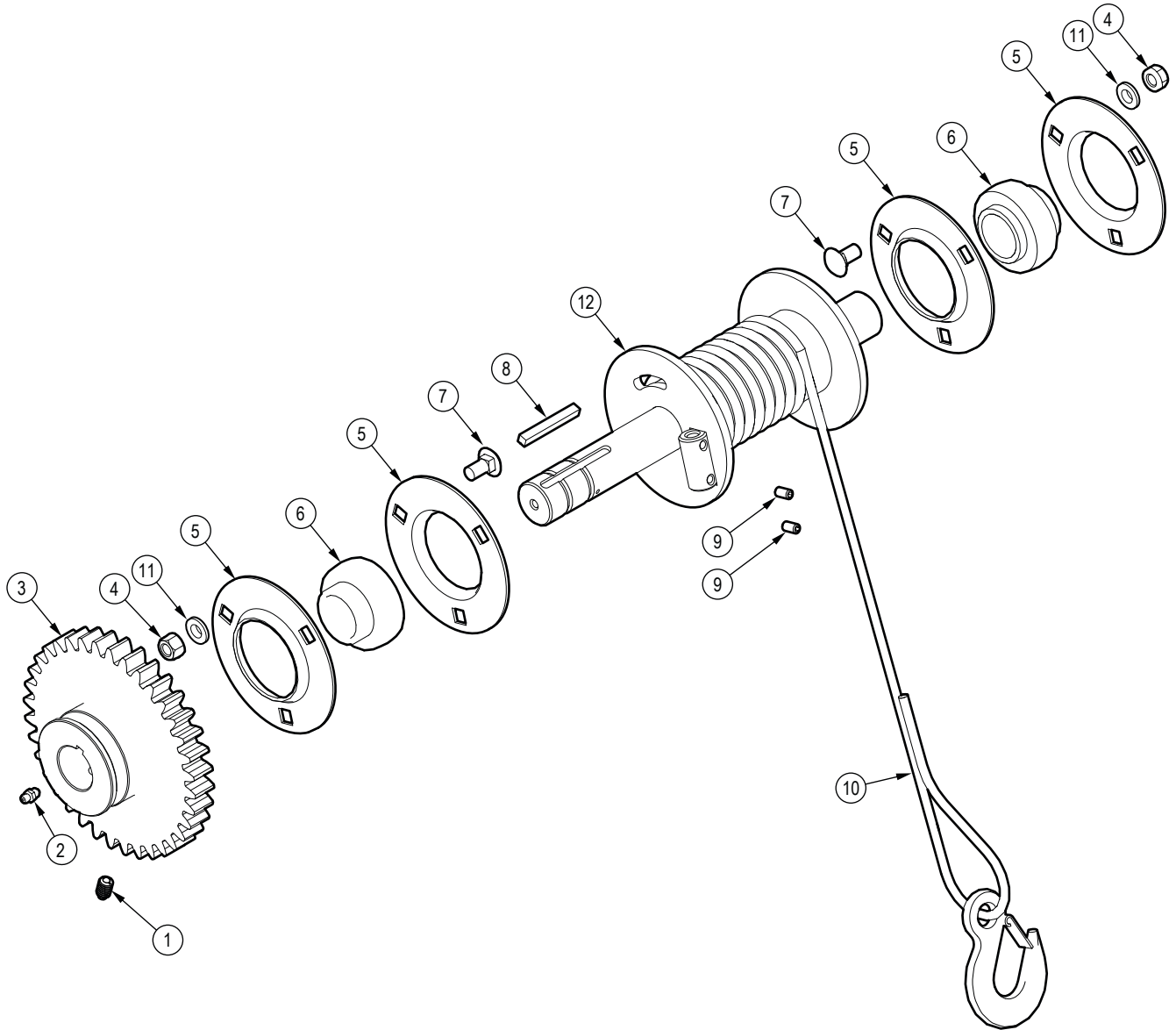

Item No.	Part No.	Description	Qty
1	Z34302	Spring Plunger, 3/8NC x 5/8" x 21 lbs	1
2	Z29202	Grease Fitting, 1/4NF	1
3	5081M125	Gear, Driven	1
4	Z72231	Hex Lock Nut, 3/8 NC	6
5	Z25301	3-Bolt Flange Bearing, PF206 x Flange Only	4
6	Z25207	Bearing Insert, UC206-20	2

Item No.	Part No.	Description	Qty
7	Z76231	Carriage Bolt, 3/8NC x 1"	6
8	Z46531	Key, 1/4" x 1/4" x 2"	1
9	Z74111	Set Screw, 1/4NC x 1/4"	2
10	Z92112	Synthetic Winch Rope, 1/4x50ft with Hook	1
11	Z73131G8	SAE Washer, 3/8" Grade 8	6
12	2251W019	Drum, Main Cable	1

**Panel Assembly**

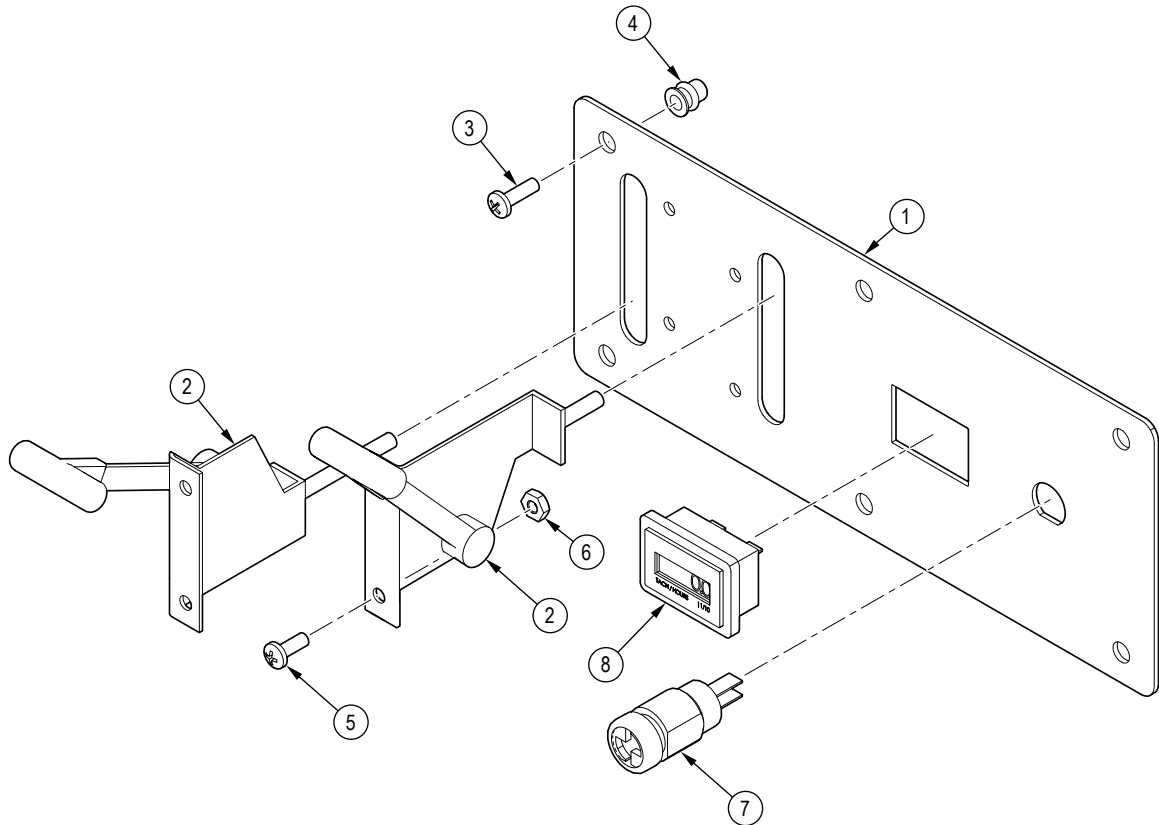

Item No.	Part No.	Description	Qty
1	2251L187	Plate, Remote Start	1
2	Z92116	Remote Throttle Cable, 66"	2
3	Z78312	Machine Screw, #10NC x 5/8"	6
4	Z72953	Rivet Nut, #10NC x 130	6
5	Z78303	Machine Screw, #10NF x 1/2"	4
6	Z72752	Machine Nut, #10NF	4

Item No.	Part No.	Description	Qty
7	Z47754	Vanguard Keyswitch Start	1
8	Z64612	Hour Meter Snap-Mount	1

## Tool Box Lid

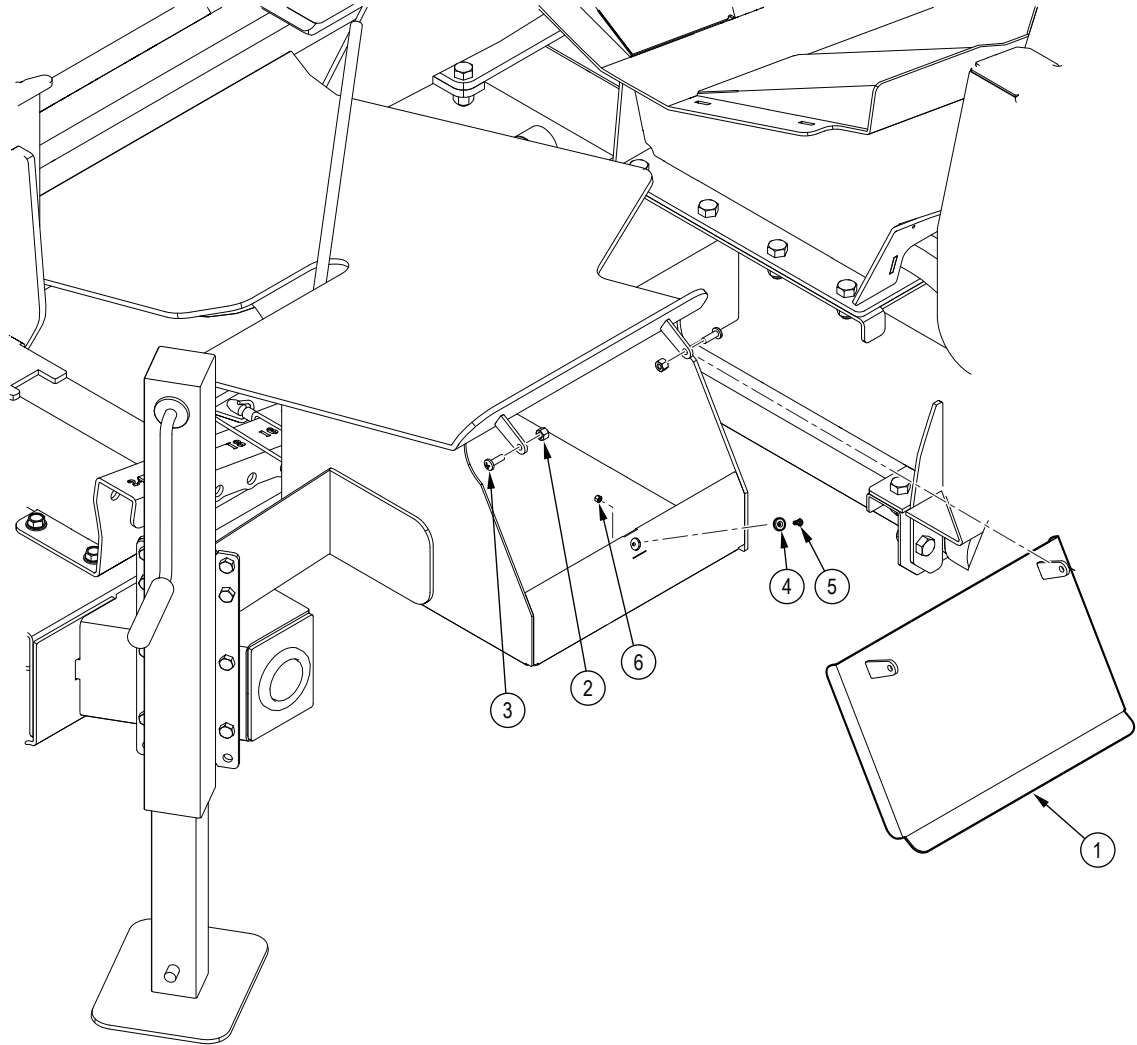

Item No.	Part No.	Description	Qty
1	2251W050	Lid, Toolbox	1
2	Z72211	Hex Lock Nut, 1/4NC	2
3	Z78301	Machine Screw, 1/4NC x 3/4"	2
4	Z19920	Puck Magnet 1-2 x 1-8	1
5	Z75207	FHCS, #4NC x 1/2"	1
6	Z72208	Hex Lock Nut, #4NC	1

**Cylinder**



Seal Kit #SLK-4525

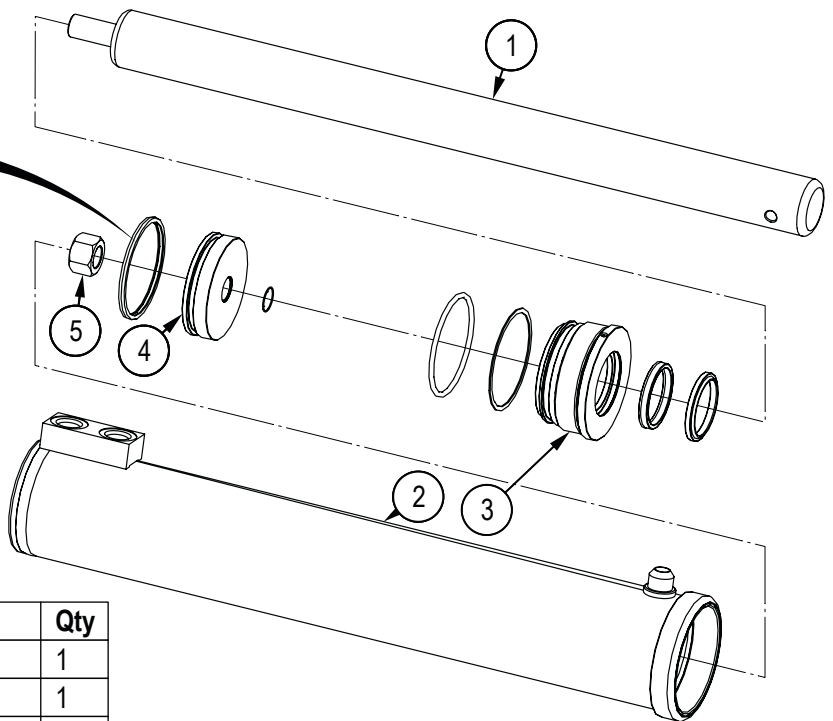

Item No.	Part No.	Description	Qty
1	2251C0012	Rod, 2-1/2x 1	1
2	2251C0014	Barrel, 4-1/2"	1
3	G450-250S	Gland, 4-1/2" x 2-1/2"	1
4	P100-450SP	Piston, 4-1/2" Bore	1
5	Z722909G8	Hex Top-lock Nut, 1-14NF G8	1

**Hub Assembly**

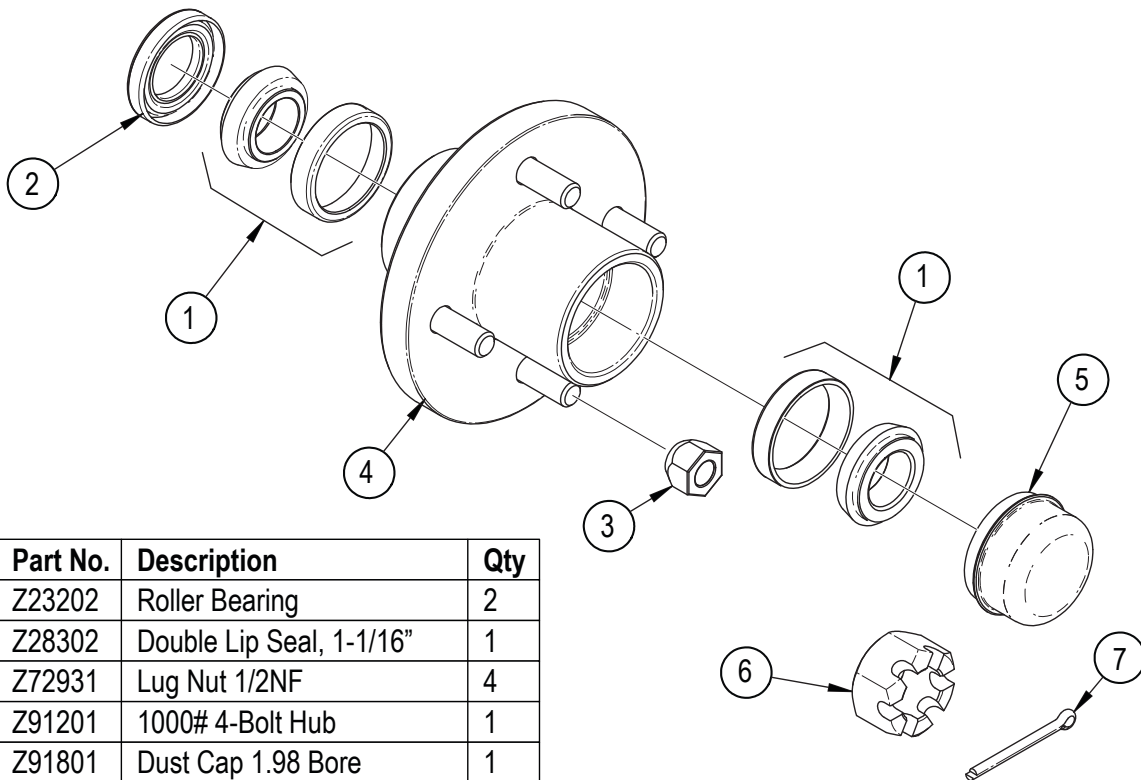

Item No.	Part No.	Description	Qty
1	Z23202	Roller Bearing	2
2	Z28302	Double Lip Seal, 1-1/16"	1
3	Z72931	Lug Nut 1/2NF	4
4	Z91201	1000# 4-Bolt Hub	1
5	Z91801	Dust Cap 1.98 Bore	1
6	Z72691	Slotted Hex Nut 1NF	1
7	Z12322	Cotter Pin 3/16 X 2	1



Lights and Harness

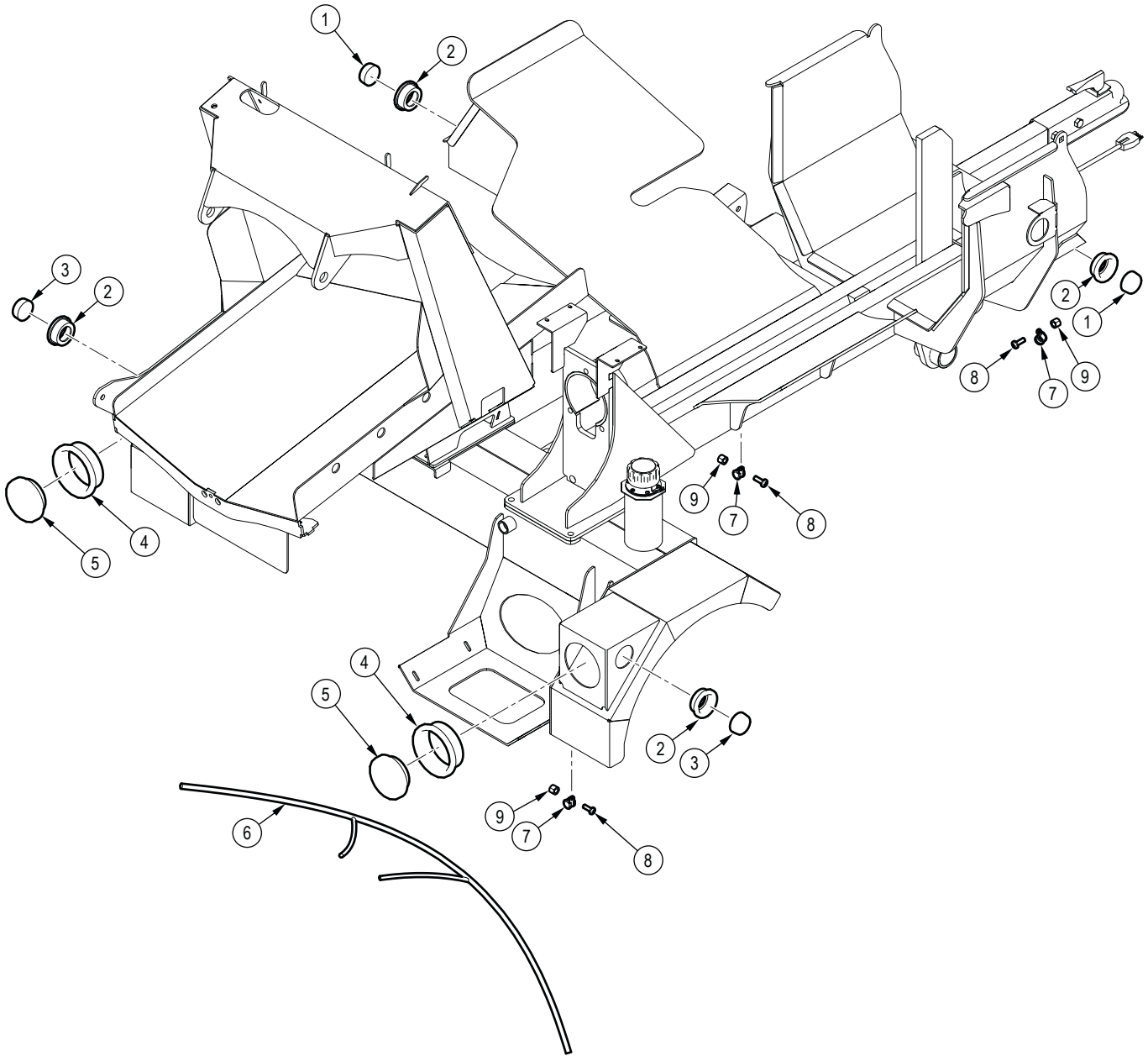

Item No.	Part No.	Description	Qty
1	Z61211	Marker LED, Round x Amber	2
2	Z61202	Grommet, Round x Open Back	4
3	Z61210	Marker LED, Round x Red	2
4	Z61116	Grommet, 4" Round x Open Back	2

Item No.	Part No.	Description	Qty
5	Z61115	STT LED, 4" Round	2
6	2251F022	Harness, WP840 VG Controls	1
7	Z62819	Rubberized Wire Clamp, 1/2"	3
8	Z78301	Machine Screw, 1/4NC x 3/4"	1
9	Z72211	Hex Lock Nut, 1/4NC	1

Valve Assembly

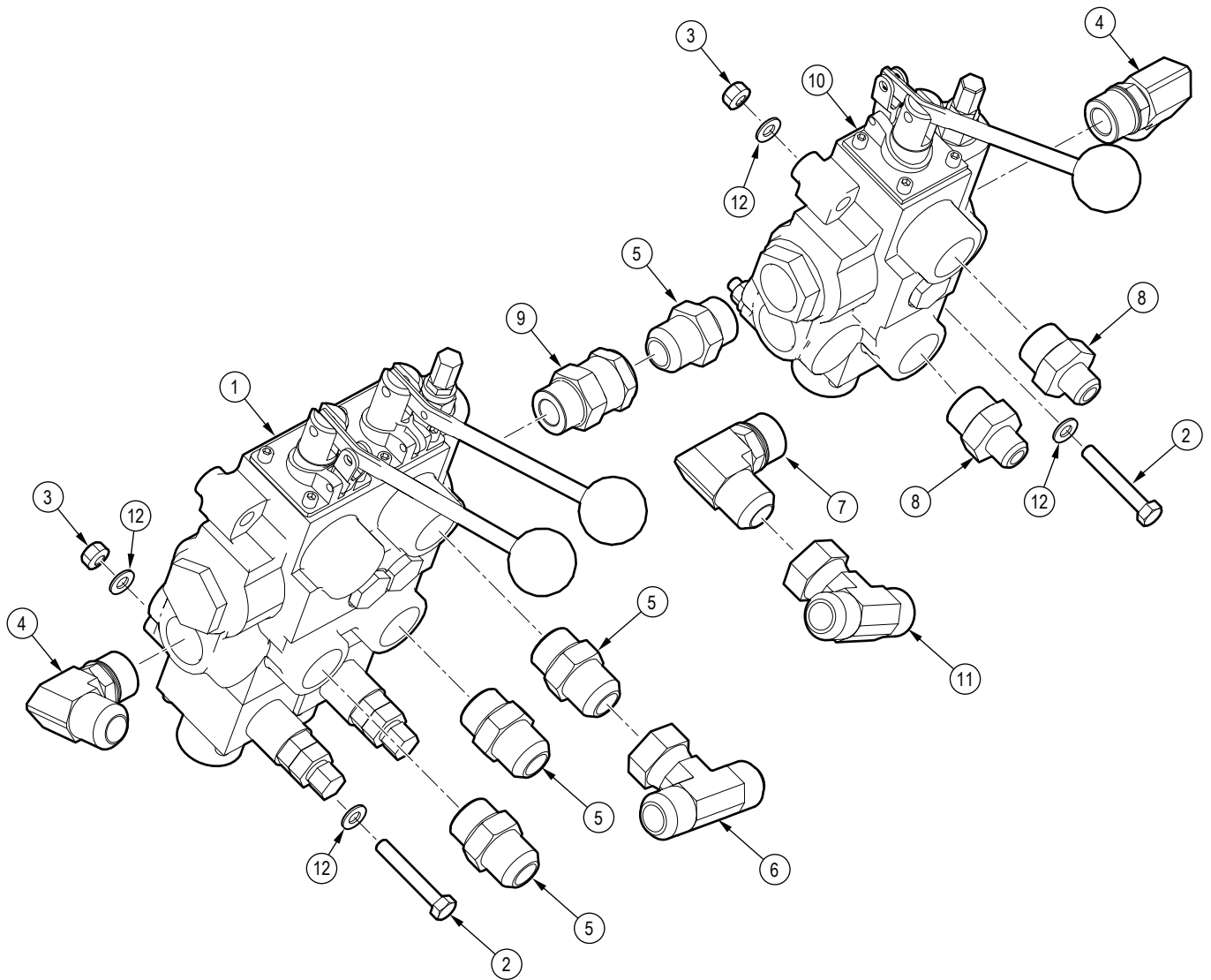

**IMPORTANT!** Serial Number SN2E9US1114MS045083 and Serial Number SN2E9US1114MS045095 and up have service bulletin SB-00117 installed, see page 28 for updated replacement parts.

Item No.	Part No.	Description	Qty
1	Z56213-1	Auto-Cycle Valve, VC x 25GPM Body Only	1
2	Z71220	Hex Bolt, 5/16NC x 2"	6
3	Z72221	Hex Lock Nut, 5/16NC	6
4	Z516501	Elbow 90, MJIC x MORB 1212	3
5	Z516414	Straight, MJIC x MORB 1212	4
6	Z51596	Tee, MJIC x MJIC x FJICX 121212	2

Item No.	Part No.	Description	Qty
8	Z516412	Straight, MJIC x MORB 0812	2
9	Z51764	Straight, MORB x FJICX 1212	1
10	Z56224	Single Spool Valve	1
12	Z73122G8	SAE Washer, 5/16" Grade 8	12

Hydraulic Circuit

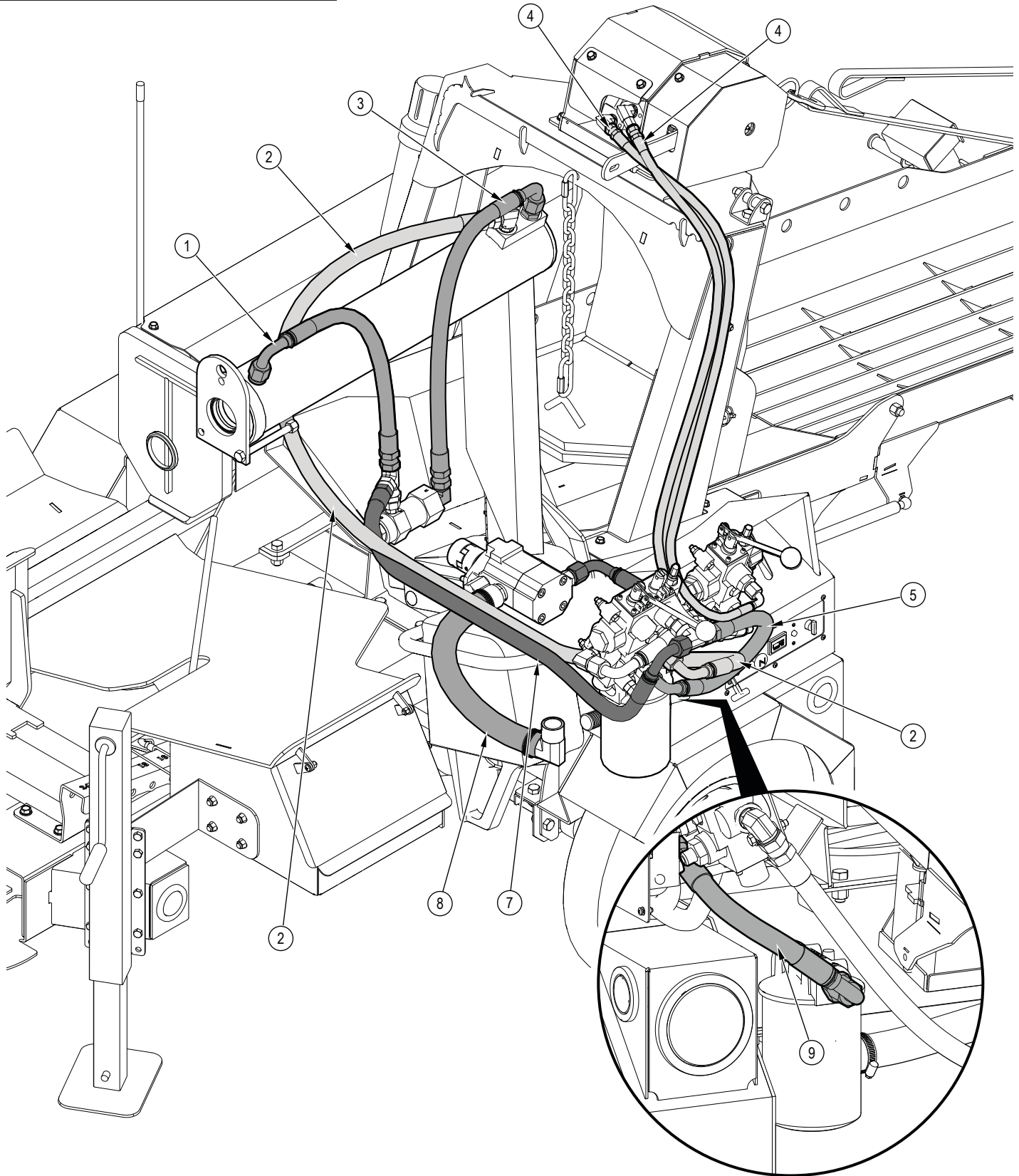

Item Number	Part No.	Description	Qty
1	2251F501	3/4" Hose x 16"	1
2	2251F510	3/4" Hose x 80"	1
3	2251F502	3/4" Hose x 33"	1
4	2251F007	3/8" Hose x 43"	2
5	2251F006	3/4" Hose x 17'	1

Item Number	Part No.	Description	Qty
7	2251F011	3/4" Hose x 34.5"	1
8	2251F018	Suction Hose, 1-1/4" x 20"	1
9	2251F021	3/4" Hose x 10"	1

Pivoting Chan Saw Holder

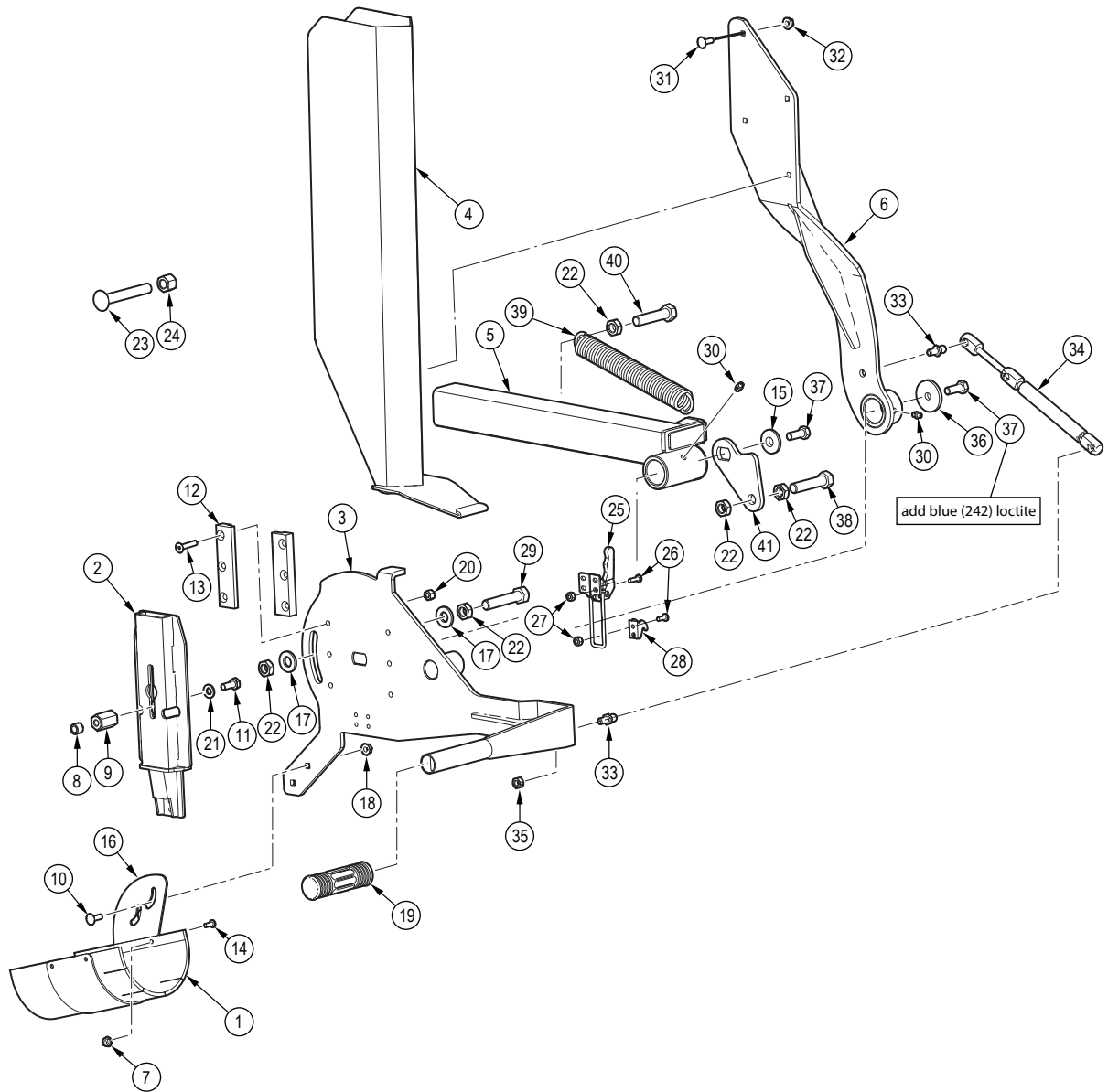

Item No.	Part No.	Description	Qty
1	2089S592	Debris Chute	1
2	2251W045	Universal Chain Saw Adapter	1
3	2251W047	Chain Saw Pivot	1
4	2089W553	Chain Saw Guard	1
5	2089W586	Chain Saw Pivot Base	1
6	2089W569	Guard Spine	1
7	Z72503	Serrated Flange Locknut, #10NF	7
8	2089M571	Bushing, Stihl Cover	2
9	2089M570	Bar Mounting Stud	9
10	Z76211	Carriage Bolt, 1/4NC x 3/4"	2
11	Z77150	Hex Bolt, M8x1.25 x 20mm	2
12	2251M009	Guide Gusset Block	2
13	Z75214	FHCS, 1/4NC x 1-1/4"	6
14	Z78303	Machine Screw, #10NF x 1/2"	4
15	2089L5501	Washer	1
18	Z72511	Serrated Flange Locknut, 1/4NC	2
19	Z19321	Handle Grip, 1"	1
20	Z72211	Hex Lock Nut, 1/4NC	6
21	Z73151	SAE Washer, 5/16"	2

Item No.	Part No.	Description	Qty
22	Z72351	Jam Nut, 1/2NC	5
23	Z762510	Carriage Bolt, 1/2NC x 3-1/2"	2
24	Z72251	Hex Lock Nut, 1/2NC	2
25	Z19516	Adjustable Draw Latch, 5" (GH-40820) Latch only	1
26	Z78324	Machine Screw, #10NF x 5/8"	6
27	Z72204	Hex Lock Nut, #10NF	6
28	Z19517	Catch for Z19516	1
29	Z71525	Hex Bolt, 1/2NC x 2-1/2"	1
30	Z29202	Grease Fitting, 1/4NF	2
31	Z76211	Carriage Bolt, 1/4NC x 3/4"	4
32	Z72511	Serrated Flange Locknut, 1/4NC	4
33	Z34208	Ball Stud, 10mm x 5/16NC	2
34	Z34209	Gas Spring, 8mm x 9.65" x 3.15" x 56 lbs	1
35	Z72223	Hex CTR-lock Nut, 5/16NC	1
36	2089L5555	Washer	1
37	Z71310	Hex Bolt, 3/8NC x 1"	1
38	Z71522	Hex Bolt, 1/2NC x 2-1/4"	1
39	Z31404	Extension Spring	1
40	Z71517	Hex Bolt, 1/2NC x 1-3/4"	1
41	2089L574	Pivot Stop Washer	1

### Decal Layout

**IMPORTANT!** If parts are replaced that have safety signs on them, new signs must be applied. Safety signs must always be replaced if they become damaged, are removed, or become illegible.

Safety signs are included in the product decal kit available from your authorized dealer. Decals are not available separately.

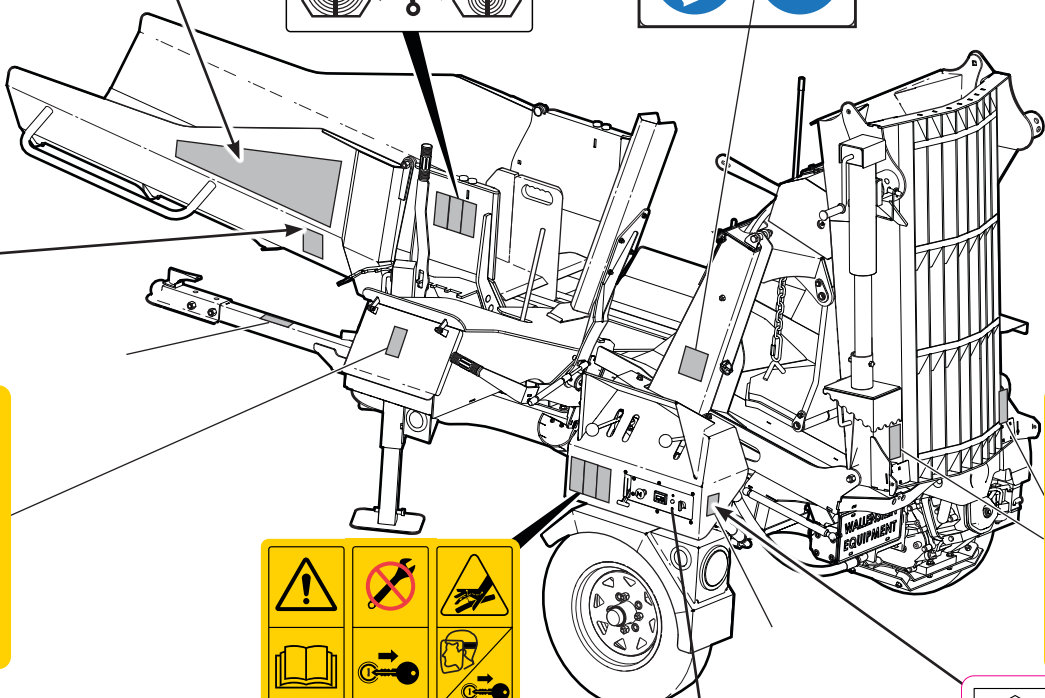
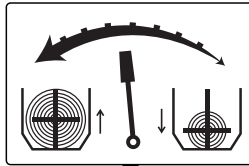
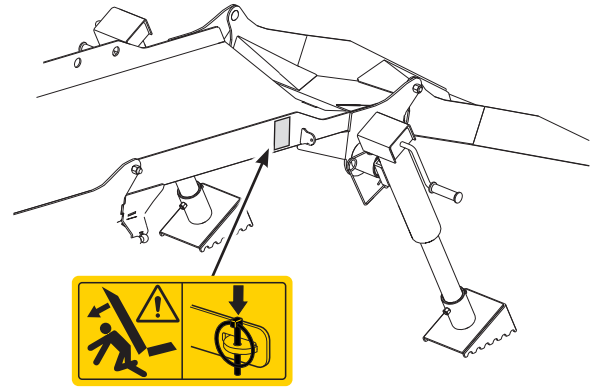

See Control Panel Decals

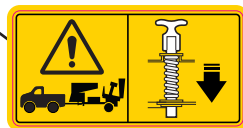
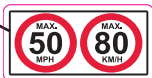
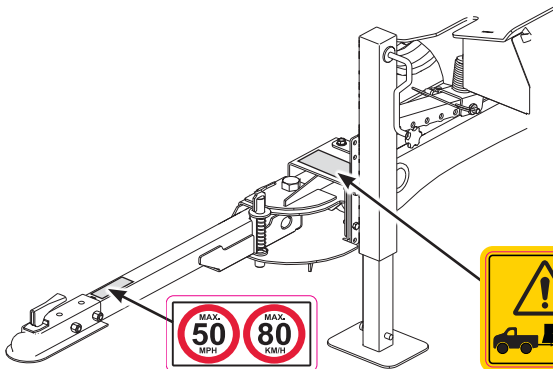
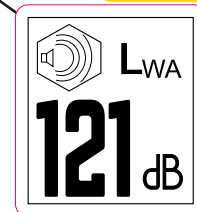

Decal Layout

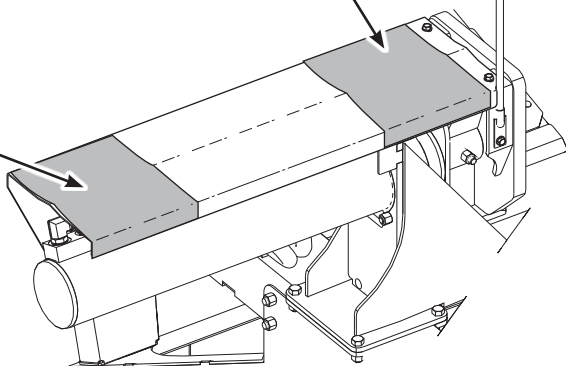
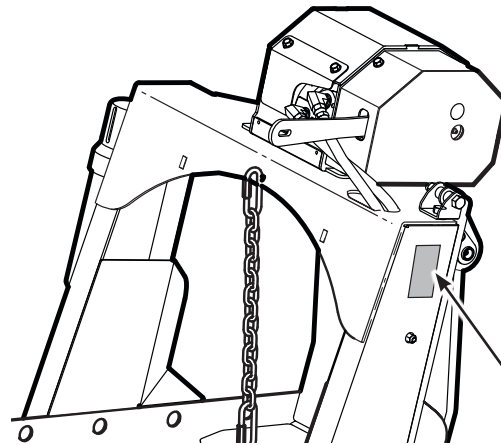
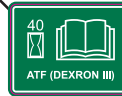
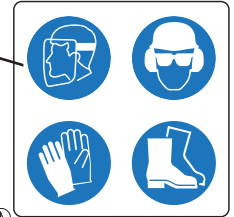
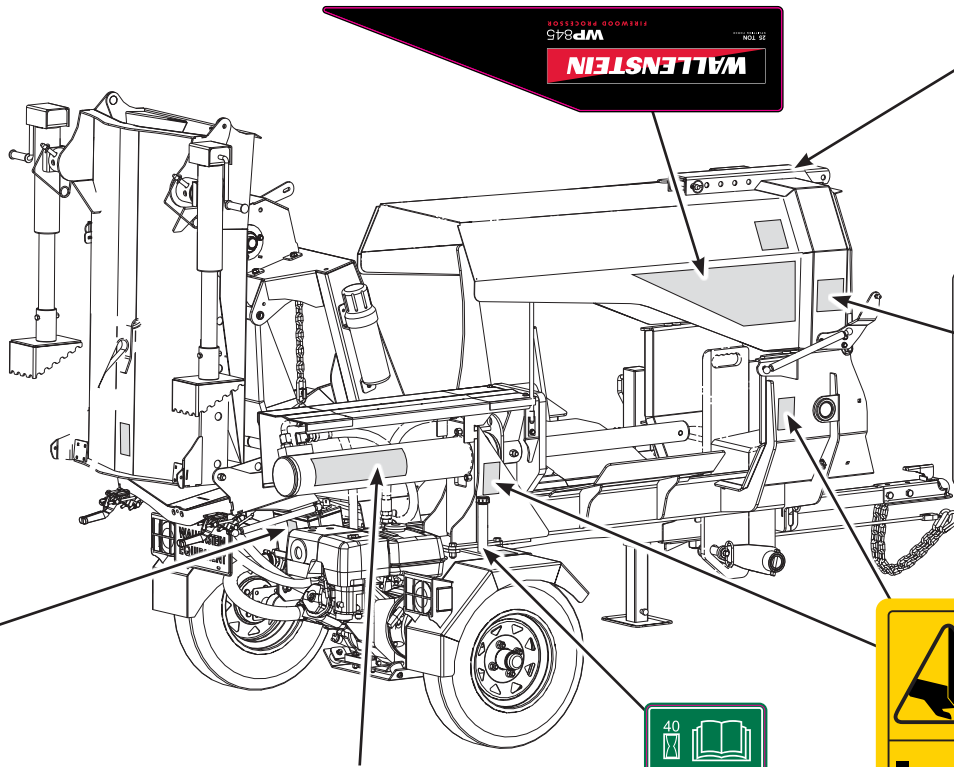
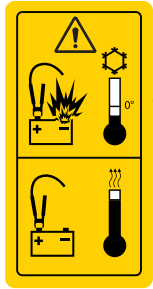

Decal Layout

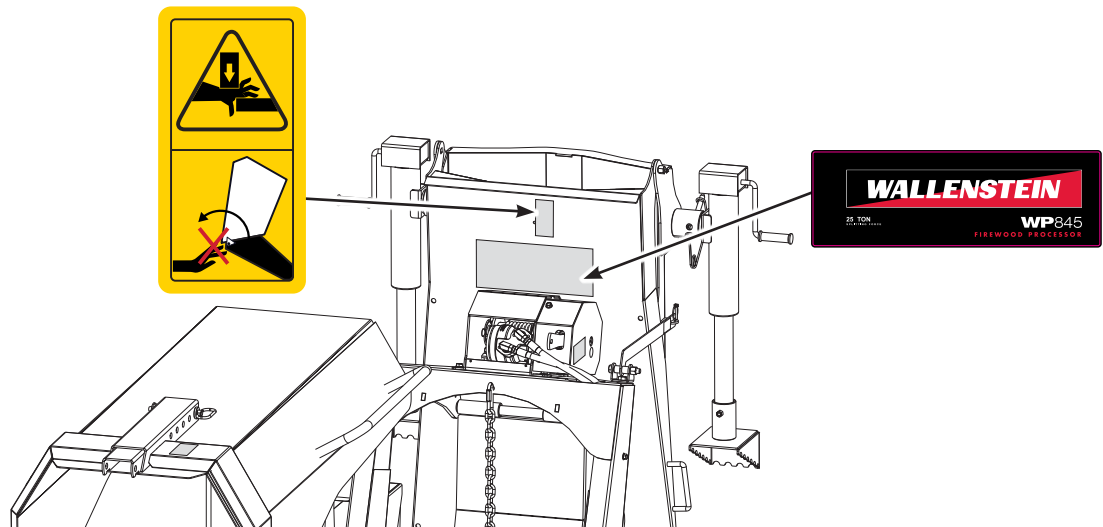
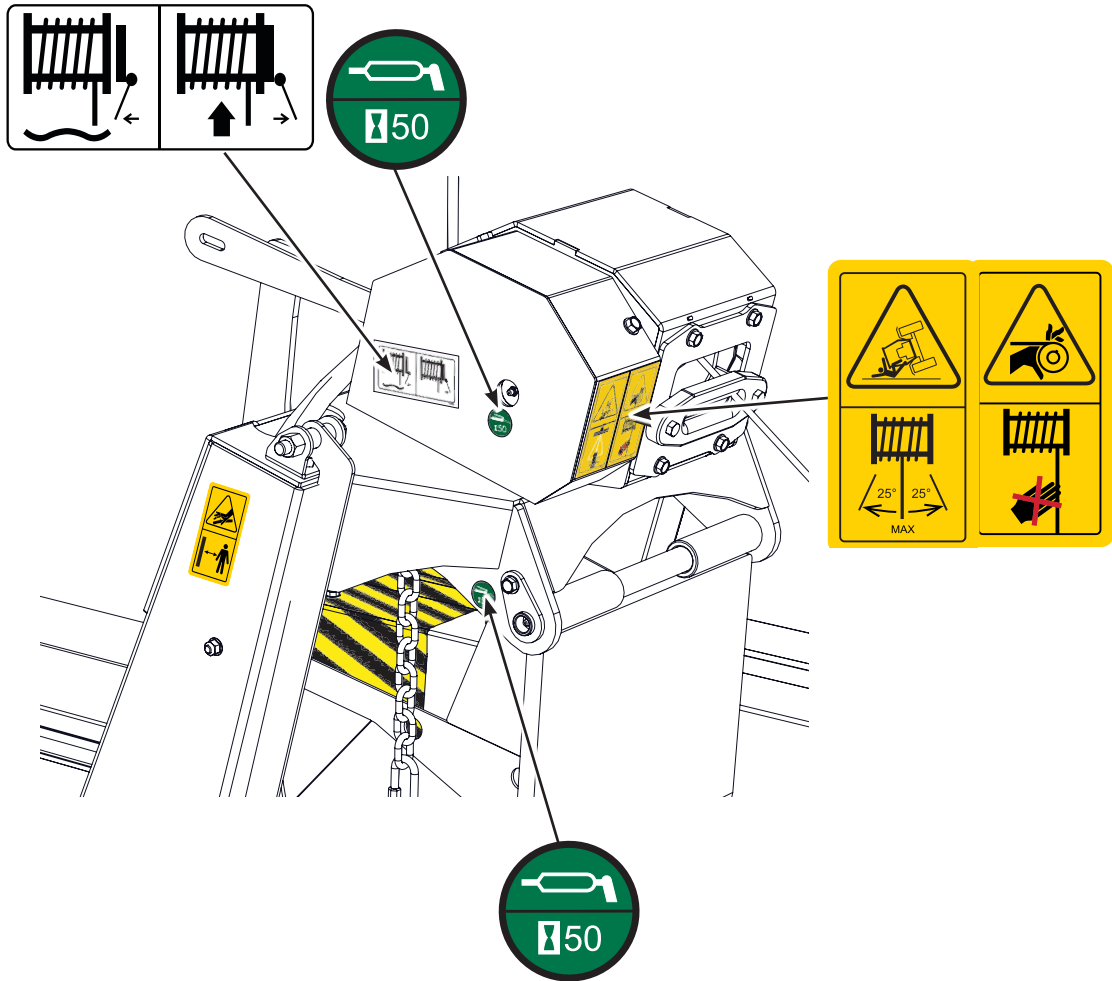

**Control Panel Decals**

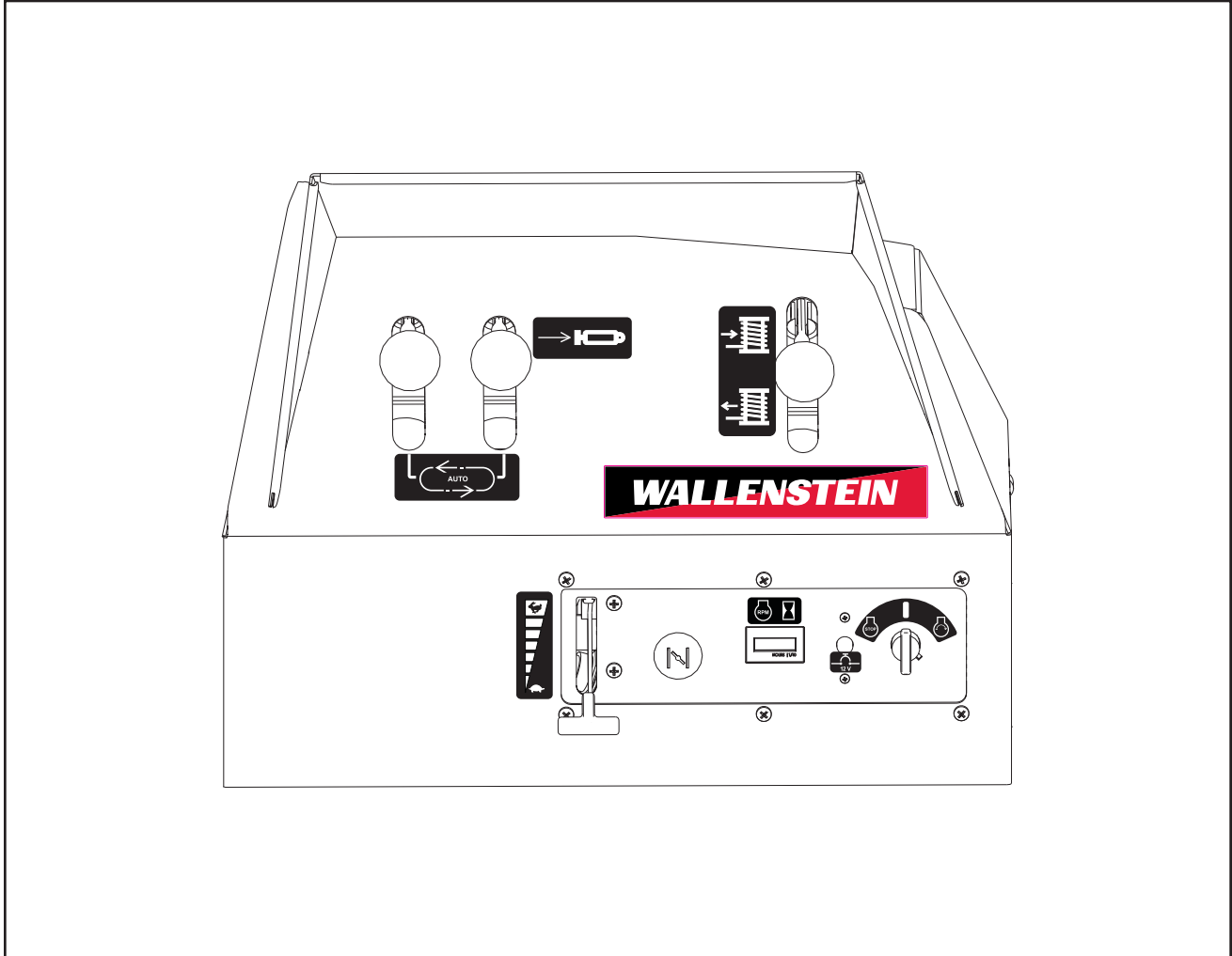



## Accessories

Call your dealer for pricing and availability

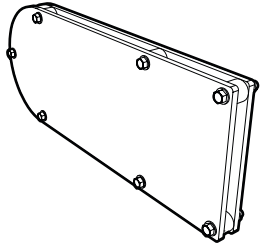

### P100 NYLON CHAINSAW HOLSTER

For models: **WP845, WP875**  
easy to install, fastens to Wood Processor

Nylon holder, safely holds your chainsaw keeping it off the ground and out of the way!

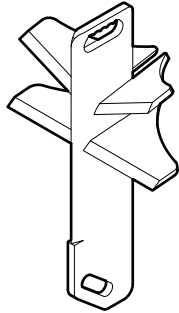

### P601 6-WAY WEDGE

Boost productivity and make quick work out of chunks by splitting into six pieces at once.

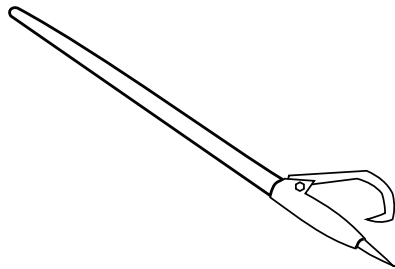

### 48" LOG PEAVEY – P/N Z99001

Helps to move those heavy log timbers into position, and finish getting your last logs through the Wood Processor!

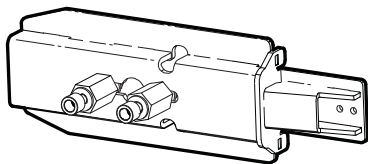

### P212 UNIVERSAL CHAIN SAW ADAPTOR

Save time by attaching a spare chain saw adaptor to a second saw.

## Common Bolt Torque Values

### Checking Bolt Torque

The tables shown give correct torque values for various bolts and capscrews. Tighten all bolts to the torque values specified in the table, unless indicated otherwise. Check tightness of bolts periodically.

**IMPORTANT!** If replacing hardware, use fasteners of the same grade.

**IMPORTANT!** Torque figures indicated in the table are for non-greased or non-oiled threads. Do not grease or oil threads unless indicated otherwise. When using a thread locker, increase torque values by 5%.

 **NOTE:** Bolt grades are identified by their head markings.

### Imperial Bolt Torque Specifications

Bolt Diameter	Torque Value					
	SAE Gr. 2		SAE Gr. 5		SAE Gr. 8	
	lbf•ft	N•m	lbf•ft	N•m	lbf•ft	N•m
1/4"	6	8	9	12	12	17
5/16"	10	13	19	25	27	36
3/8"	20	27	33	45	45	63
7/16"	30	41	53	72	75	100
1/2"	45	61	80	110	115	155
9/16"	60	95	115	155	165	220
5/8"	95	128	160	215	220	305
3/4"	165	225	290	390	400	540
7/8"	170	230	420	570	650	880
1"	225	345	630	850	970	1320



SAE Gr. 2



SAE Gr. 5



SAE Gr. 8

### Metric Bolt Torque Specifications

Bolt Diameter	Torque Value			
	Gr. 8.8		Gr. 10.9	
	lbf•ft	N•m	lbf•ft	N•m
M3	0.4	0.5	1.3	1.8
M4	2.2	3	3.3	4.5
M6	7	10	11	15
M8	18	25	26	35
M10	37	50	52	70
M12	66	90	92	125
M14	83	112	116	158
M16	166	225	229	310
M20	321	435	450	610
M30	1,103	1 495	1,550	2 100



8.8



10.9

### Hydraulic Fitting Torque Values

#### Tightening Flare Type Tube Fittings

1. Check flare and flare seat for defects that might cause leakage.
2. Align tube with fitting before tightening.
3. Hand-tighten swivel nut until snug.
4. To prevent twisting the tube, use two wrenches. Place one wrench on the connector body and tighten the swivel nut with the second. Torque to values shown.

If a torque wrench is not available, use the FFFT (Flats From Finger Tight) method.

Hydraulic Fitting Torque					
Tube Size OD	Hex Size Across Flats	Torque value		Flats From Finger Tight	
		lbf•ft	N•m	Flats	Turns
3/16	7/16	6	8	2	1/6
1/4	9/16	11–12	15–17	2	1/6
5/16	5/8	14–16	19–22	2	1/6
3/8	11/16	20–22	27–30	1-1/4	1/6
1/2	7/8	44–48	59–65	1	1/6
5/8	1	50–58	68–79	1	1/6
3/4	1-1/4	79–88	107–119	1	1/8
1	1-5/8	117–125	158–170	1	1/8

Values shown are for non-lubricated connections.

### Wheel Lug Torque Values

It is extremely important safety procedure to apply and maintain proper wheel mounting torque on your trailer axle. Torque wrenches are the best method to assure the proper amount of torque is being applied to a fastener.

Wheel lugs should be torqued before first road use and after each wheel removal. Check and re torque after the first 10 miles (16 km), 25 miles (40 km), and again at 50 miles (80 km). Check periodically thereafter.

**NOTE:** *Wheel lugs must be applied and maintained at the proper torque levels to prevent loose wheels, broken studs, and possible dangerous separation of wheels from your axle.*

- Start all lugs by hand to prevent cross threading.
- Tighten lugs in sequence, per wheel lug torque sequence chart.
- The tightening of the fasteners should be done in stages. Following the recommended sequence, tighten fasteners per wheel torque requirements chart.

Wheel Lug Nut Torque				
Wheel Size	Units	1st Stage	2nd Stage	3rd Stage
8"	lbf•ft N•m	12–20 16–26	30–35 39–45.5	45–55 58.5–71.5
12"	lbf•ft N•m	20–25 26–32.5	35–40 45.5–52	50–60 65–78
13"	lbf•ft N•m	20–25 26–32.5	35–40 45.5–52	50–60 65–78
14"	lbf•ft N•m	20–25 26–32.5	50–60 65–78	90–120 117–156
15"	lbf•ft N•m	20–25 26–32.5	50–60 65–78	90–120 117–156
16"	lbf•ft N•m	20–25 26–32.5	50–60 65–78	90–120 117–156

Wheel Lug Torque Pattern

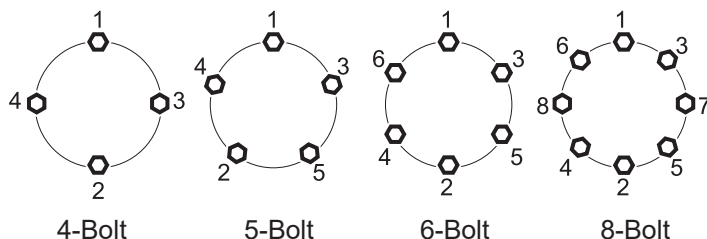

**Service Bulletin SB-00117**

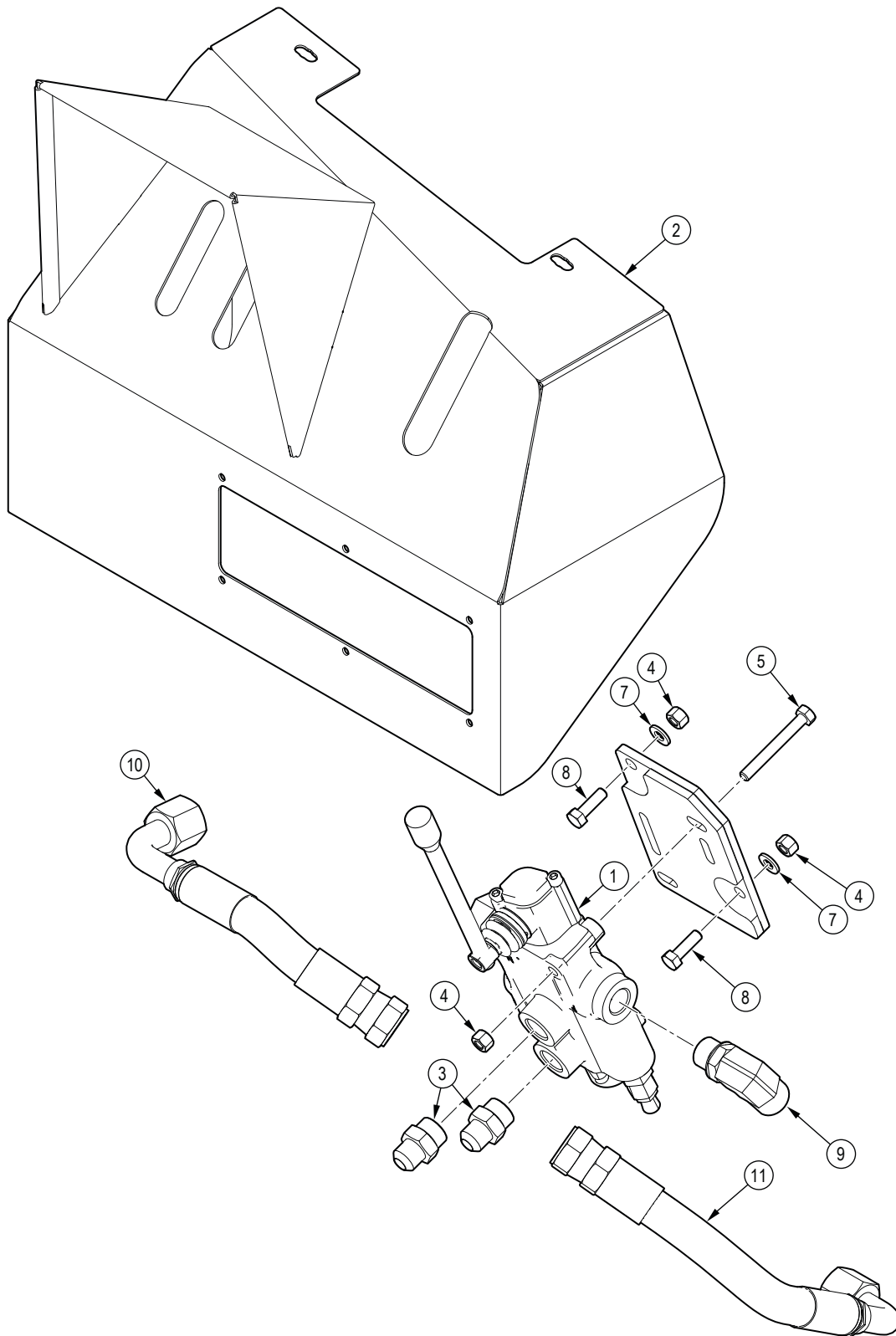

Item No.	Part No.	Description	Qty
1	Z56232	Single Spool Valve, OC Tandem PB	1
2	2251W059	Weldment, Valve Cover	1
3	Z51647	Straight, MJIC x MORB 0810	2
4	Z72221	Hex Lock Nut, 5/16NC	4
5	Z71225	Hex Bolt, 5/16NC x 2-1/2"	2

Item No.	Part No.	Description	Qty
7	Z73122G8	SAE Washer, 5/16" Grade 8	2
8	Z71210	Hex Bolt, 5/16NC x 1"	2
9	Z51654	Elbow 90, MJIC x MORB 1210	1
10	2251F023	3/4" Hose, FJIC12 x 90FJIC12 x 6"	1
11	2251F024	3/4" Hose, FJIC12 x 90FJIC12 x 9.5"	1