

EMB Manufacturing Inc.

4144 Boomer Line · St. Clements, On · N0B 2M0 · Canada
Ph: (519) 699-9283 · Fax: (519) 699-4146
www.embmfg.com

W4212 Splitter Folding Shelf #2073A151

W4212 is compatible with these models:

WX510	WX515	WX520	WX520T	WX615	WX620	WX620T
WX910	WX910T	WX920	WX930	WXR720		

Note: W4212 is not compatible and cannot be installed with W4211 Clamp On Shelf



This Safety Alert symbol means

ATTENTION! BECOME ALERT! YOUR SAFETY IS INVOLVED!

The Safety Alert symbol identifies important safety messages in this instruction, as well as on the machine and in the operators manual. When you see this symbol, be alert to the possibility of personal injury or death. Follow the instructions in the safety message.



Caution: this kit is constructed of heavy gauge steel, be sure to use caution moving and installing the kit, avoid dropping or pinching body parts on corners and edges of the kit.



Always wear the appropriate safety gear when installing this kit or working around the machine. This includes but is not limited to:

- Hard hat for protection to the head.
- Face mask for protection to the face and eyes from flying chips.
- Heavy gloves for protection from slivers, chips and pinching.
- Safety shoes with slip resistant soles and steel toes for protection from dropped logs and pieces of wood.



#W4212 SHOWN MOUNTED
ON WXR720

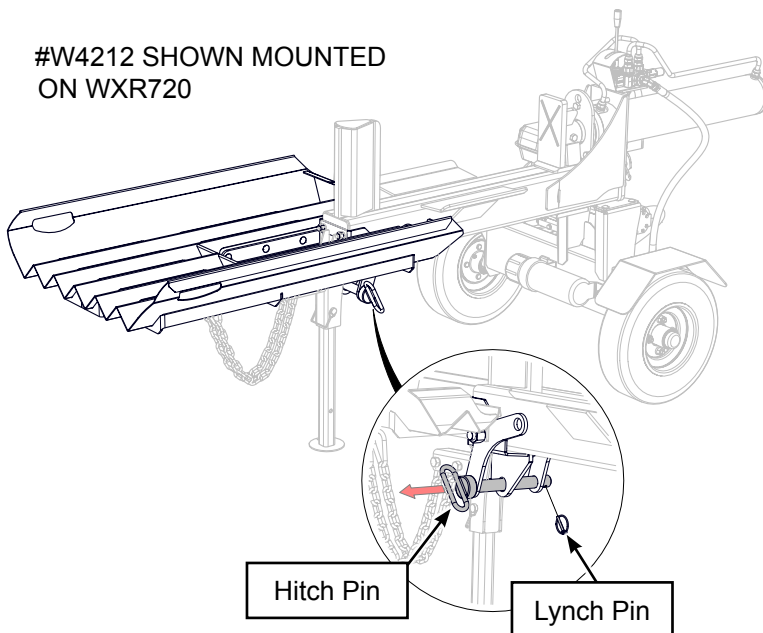

W4212 SPLITTER FOLDING SHELF:

The splitter folding shelf is designed to be easily installed and will help reduce back strain from repeated bending and lifting. The shelf catches the split wood of the end of the splitter, making it easier to retrieve for a secondary split.

The shelf can be folded up for transport and storage.

- Remove the lynch pin from the hitch pin,
- Carefully remove the hitch pin,
- Fold the shelf up,
- Reinsert the hitch pin, and secure with the lynch pin.

PRINTED IN CANADA
Rev: 180417

PART NUMBER: Z97823

over:

INSTALLATION INSTRUCTIONS

! Ensure your wood splitter and the area around it is clean and free of debris, resting on dry level ground, wheel chock applied and the engine shut off. Have the shelf kit and tools close by on a work surface.

Unpack the shelf kit. Lay the parts out on the work surface and use the parts list in the back of this manual to check that all parts are included. All hardware will be in a plastic bag attached to the main shelf.

Basic tools needed: 3/4" wrench or socket

1. Rotate the shelf base so the shelf will be in the "up" position during assembly.

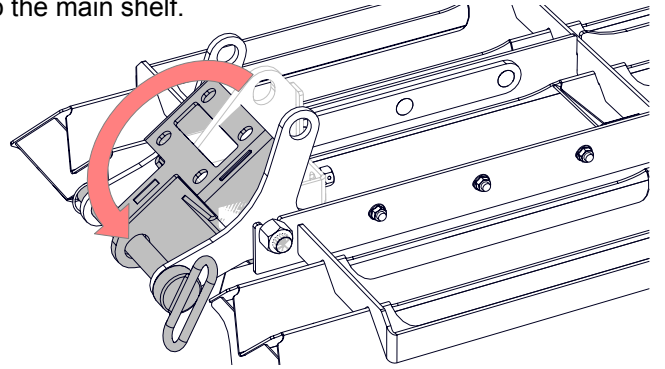

2. Support the wood splitter so the stand is not supporting any weight, then remove the stand/hitch assembly. Discard the nuts.

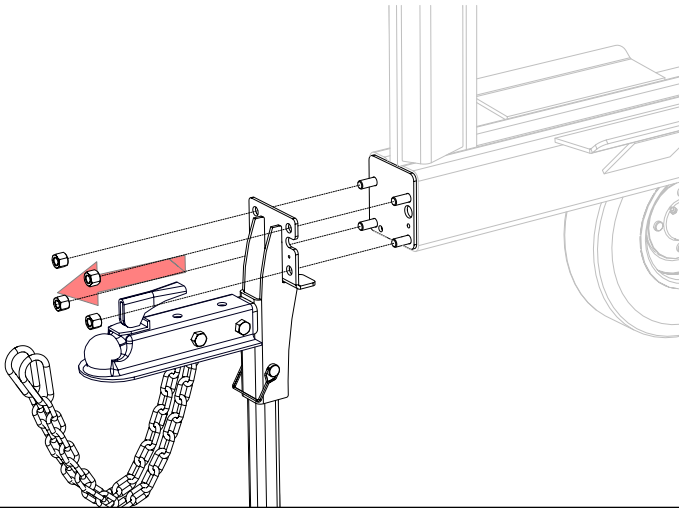

3. With a helper, position the shelf base on to the four mounting bolts. While your helper holds the shelf in place, fit the stand/hitch assembly over the shelf base. Secure the whole build with the four lock nuts supplied with the kit.

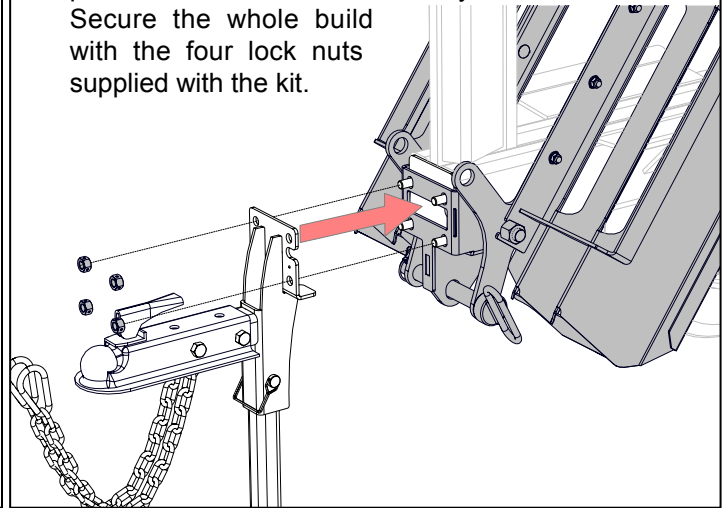

Parts

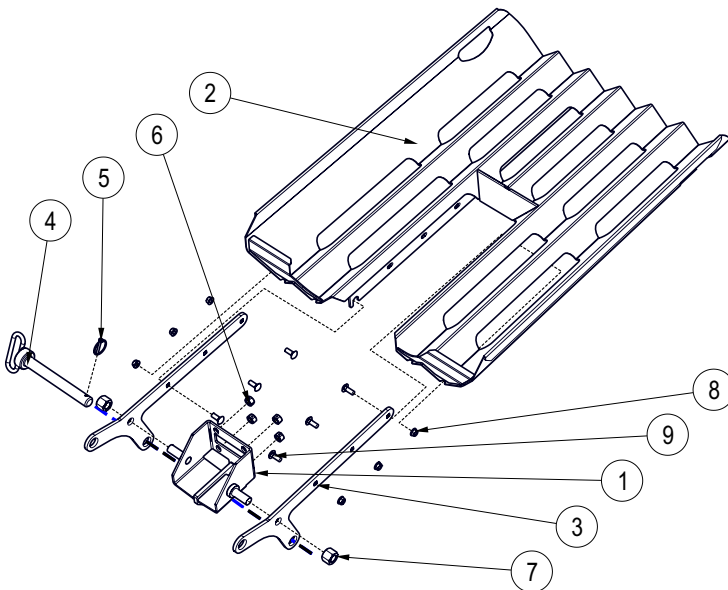

BOM ID	Part No.	Description	Qty
1	2073W051	Weldment, Shelf Base	1
2	2073W052	Weldment, Shelf Option	1
3	2073L053	Shelf Pivot Arm	2
4	Z11263	Hitch Pin, 1" x 7-1/2"	1
5	Z12110	Lynch Pin, 3/16"	1
6	Z72253	Hex CTR-lock Nut, 1/2NC	4
7	Z72271	Hex Lock Nut, 3/4NC	2
8	Z72531	Serrated Flange Locknut, 3/8NC	6
9	Z76231	Carriage Bolt, 3/8NC x 1"	6

! **Warning:** Only one worker should operate and load the splitter. A potentially dangerous pinching or crushing hazard arises when the worker loading the machine does not control the hydraulic ram.