



EMB Manufacturing Inc.
4144 Boomer Line · St. Clements, On · N0B 2M0 · Canada
Ph: (519) 699-9283 · Fax: (519) 699-4146
www.embmfg.com

BXMC32S Chipper - Shredder Parts Manual

Starting with S/N 1MC3201

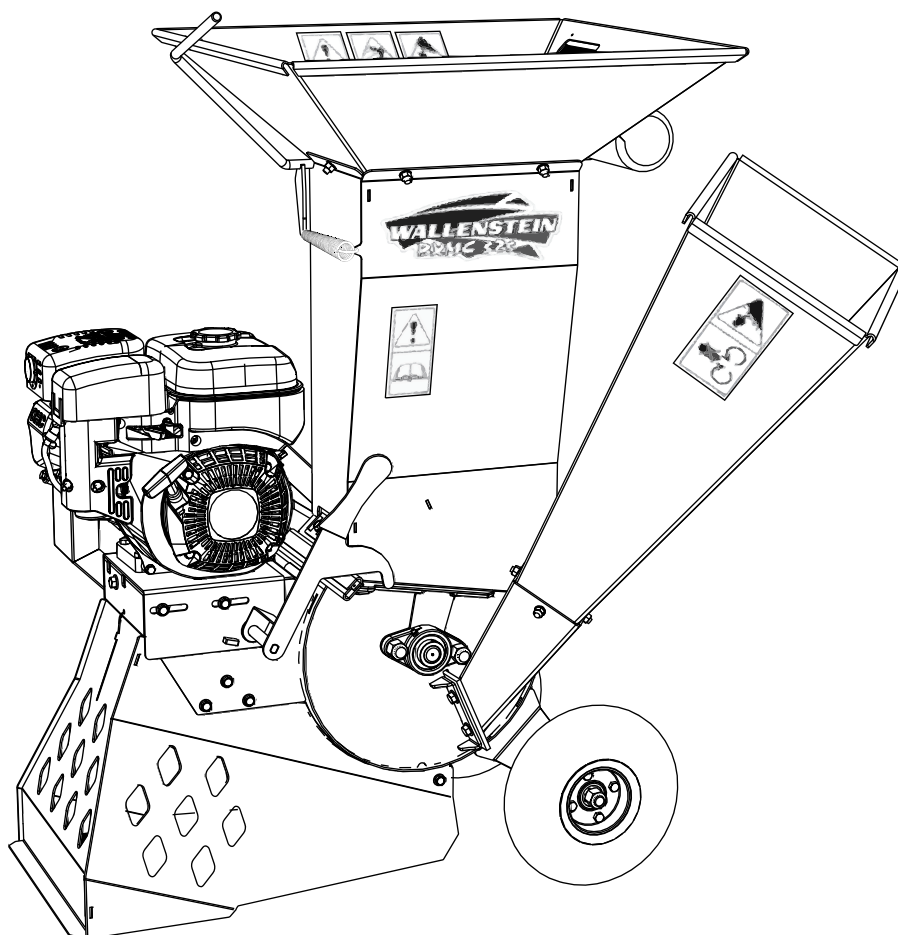

Table of Contents

DRIVE TRAIN.....	3
UPPER ROTOR ASSEMBLY	4
LOWER ROTOR ASSEMBLY	5
LABEL LAYOUT.....	6
ACCESSORIES.....	7

Foreword

EMB Mfg. has prepared this parts manual to assist customers in ordering quality OEM replacement parts.

Proper and regular service and replacing old, worn or broken parts with the correct Wallenstein parts are essential to prolonging the life of your Wallenstein product. Please refer to this manual before ordering any replacement parts.

All information contained in this parts manual is based on the latest product specification available at the time of printing this manual. If your product differs from the specifications contained within this manual contact EMB Mfg. for information.

EMB reserves the right to alter specifications on their products at any time.

Reproduction of this parts manual of any kind is prohibited without prior written permission from EMB Mfg.



Refer to the operators
manual for safe operation
and maintenance

For parts and information please contact your dealer. If your dealer is no longer available please go to our website: <http://www.embmfg.com> and click on "FIND A DEALER NEAR YOU" for information on a local dealer.

Upper Rotor Housing

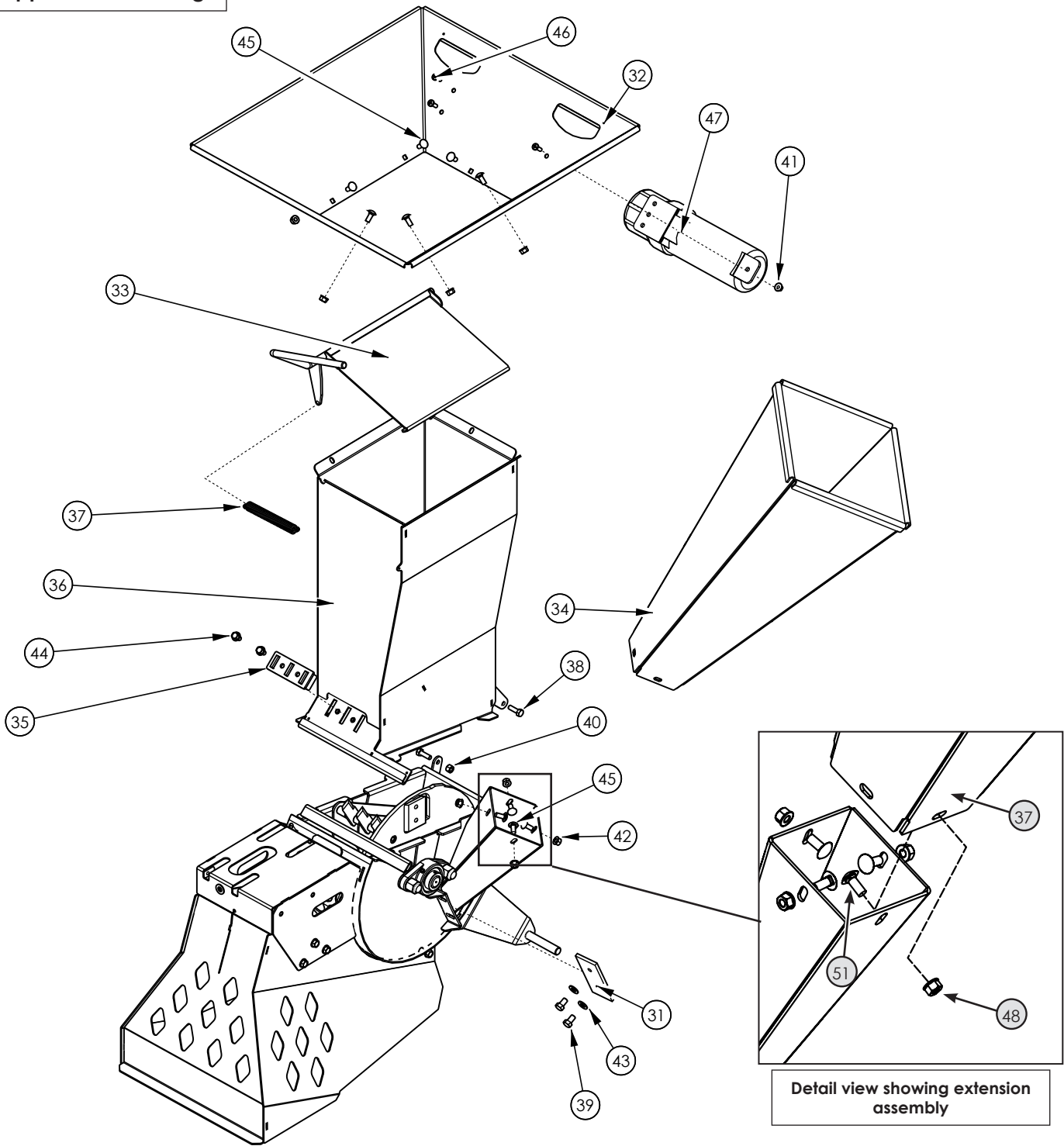

Item	Part Number	Description	Qty
31	1056M304	Knife, 3" Ledger	1
32	1073W106	Hopper	1
33	1073W107	Flap, Hopper	1
34	1073W112	Extension Weldment	1
35	1073W125	Chop Block	1
36	1074W104	Weldment, Upper Housing	1
37	Z31301	Spring 17mm x 140mm Medium	1
38	Z71210	Hex Bolt, 5/16NC x 1	2
39	Z71372G8	Hex Bolt, 3/8NF x 5/8 G8	2

Item	Part Number	Description	Qty
40	Z72221	Hex Lock Nut, 5/16NC	2
41	Z72511	Hex Flange Nut, 1/4NC	3
42	Z72521	Flange Nut 5/16NC	6
43	Z73131	Flat Washer, 3/8	2
44	Z76122	Flange Bolt, 5/16NC x 1/2	4
45	Z76221	Carriage Bolt, 5/16NC x 3/4	10
46	Z78301	Machine Screw, 1/4-20NC x 3/4	3
47	Z96503	Manual Tube 3-1/2 Short	1

Lower Rotor Housing

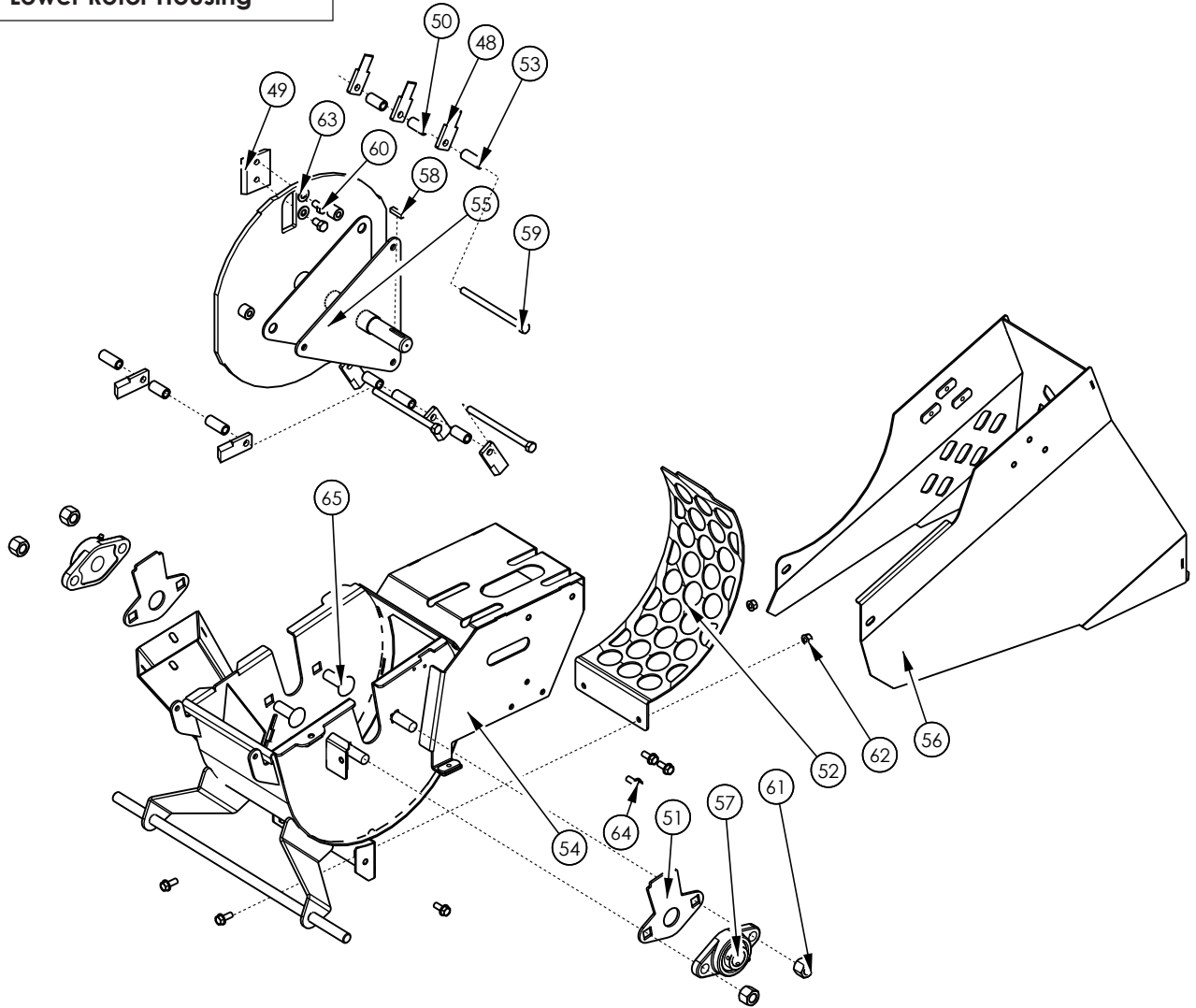

Item	Part Number	Description	Qty
48	1056M108	Knife,Shredder	8
49	1056M303	Knife, 3" Rotor	2
50	1073M104	Spacer, Shredder 1.25	5
51	1074L216	Bearing Cover Plate	2
52	1074L250	1-1/2" Round Screen	1
53	1074M105	Filler Spacer	4
54	1074W102	Weldment, Bottom Housing	1
55	1074W103	Rotor	1
56	1074W120	Shredder Guard	1
57	Z25101	FL 2-Bolt Flange Bearing 1"	2

Item	Part Number	Description	Qty
58	Z46533	Key, 1/4 x 1/4 x 1	1
59	Z71355G8	Hex Bolt, 3/8-16 x 5-1/2 G8	3
60	Z71372G8	Hex Bolt, 3/8NF x 5/8 G8	4
61	Z72261	Hex Lock Nut, 5/8NC	4
62	Z72521	Flange Nut 5/16NC	2
63	Z73131	Flat Washer, 3/8	5
64	Z76121	Flange Bolt, 5/16NC x 3/4	10
65	Z76262	Carriage Bolt, 5/8NC x 1-3/4	4

BXMC32S knife / spacer sequence

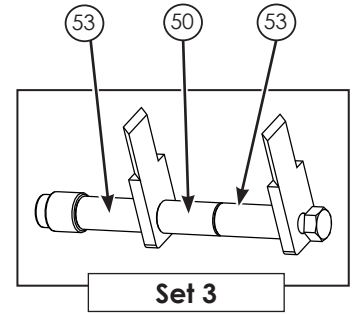
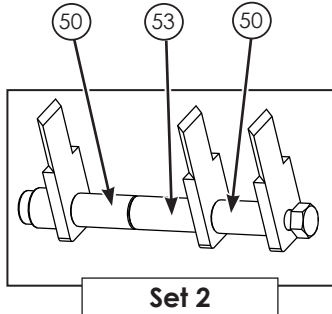
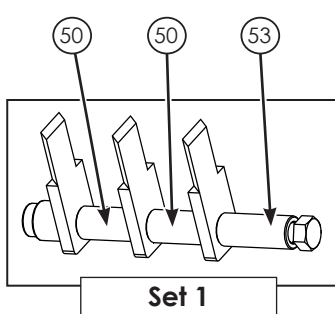

Label Layout

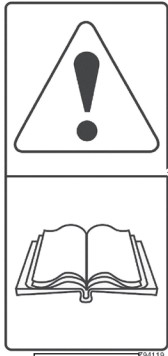

Z94119

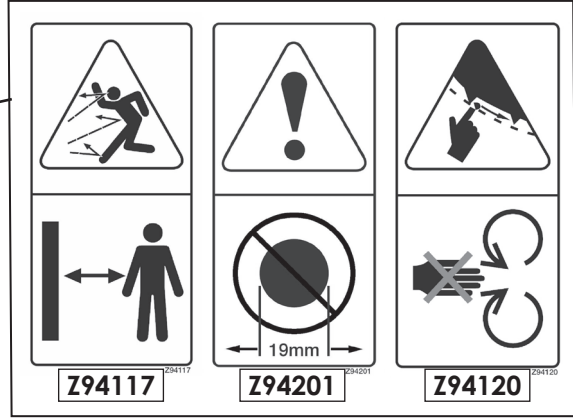

Z94117

Z94201

Z94120

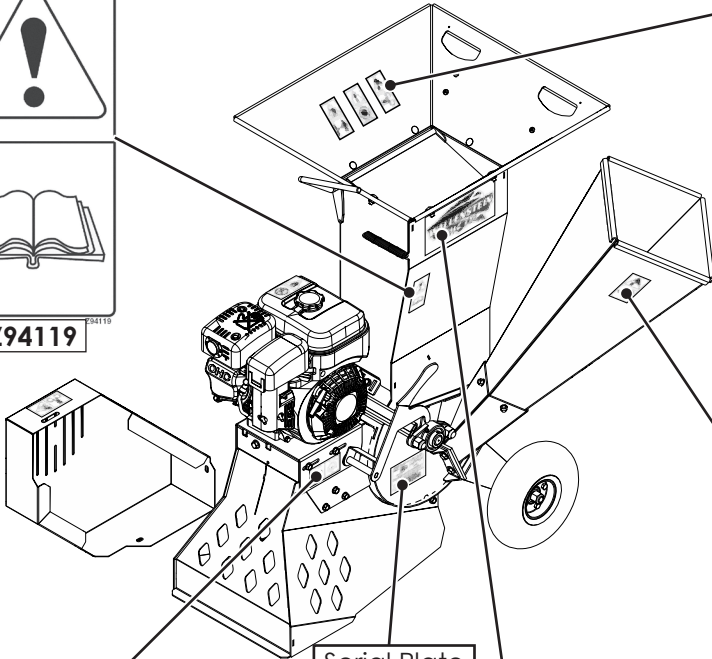

Serial Plate Location



Z94611

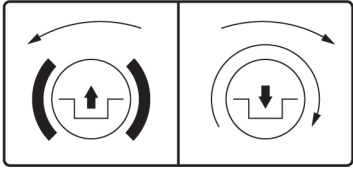

Z94410

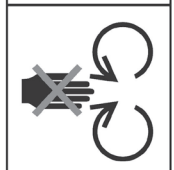
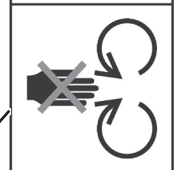

Z94120

Z94116



Z94617



Z94163

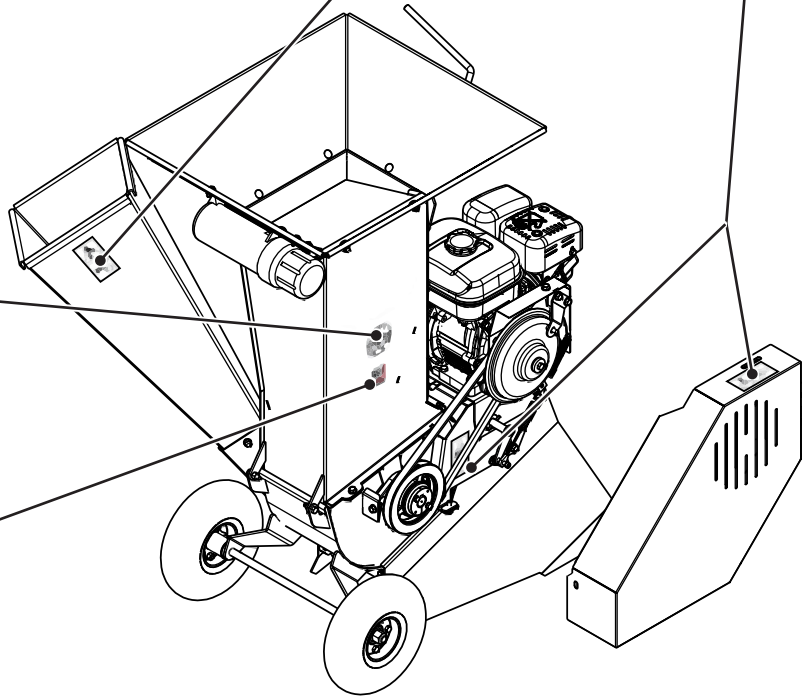

Accessories

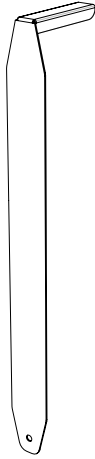

#1012L269 LEDGER CLEARANCE SETTING GAUGE

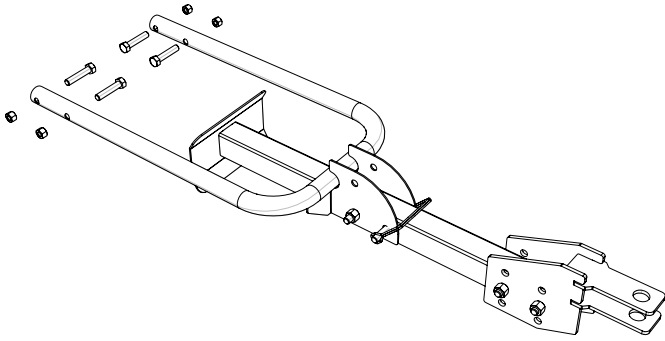

#1082A355 GARDEN TRACTOR HITCH

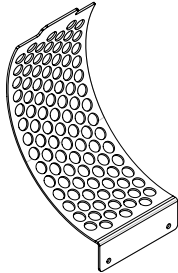

#1074L240 3/4" ROUND SCREEN (19MM)

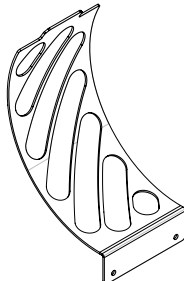

#1074L260 1 1/2" X 7.0 OBOURND WET SCREEN

Manual

WALLENSTEIN
BY EMB MFG INC.

EMB Manufacturing Inc.
4144 Boomer Line - St. Clements, On - N0B 2M0 - Canada
Ph: (519) 699-8283 - Fax: (519) 699-4146
www.embmfg.com

BXMC32B

BXMC32S

**CHIPPER-SHREDDER
MODELS BXMC32B & BXMC32S**

OPERATOR'S MANUAL

PRINTED IN CANADA
Rev: 231211

PART NUMBER: Z97061

Z97061

Available as a download at
www.embmfg.com