

# PARTS MANUAL

---

Serial Number 2E9US1110ES370010 and up

Serial Number 370016 to 370065, 100049, and 1100000 to 1100759

## WX970 TRAILER LOG SPLITTER

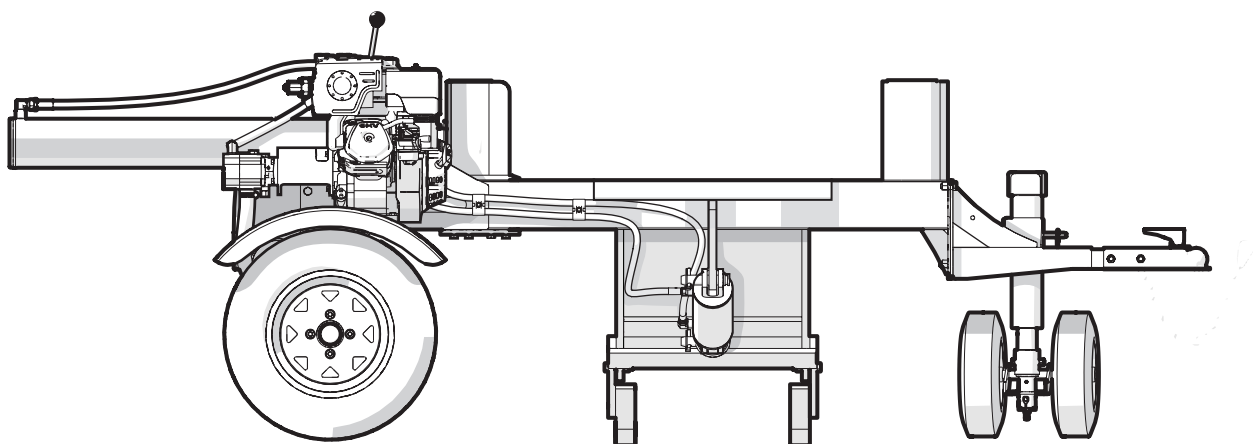

## Foreword

This Wallenstein parts manual is prepared to assist customers in ordering quality OEM replacement parts.

Regular maintenance combined with replacing old, worn or broken parts with the correct OEM parts is essential in prolonging the life of your Wallenstein product. Refer to this manual to identify replacement parts.

To order parts, contact your Wallenstein dealer or distributor. Have the product model and serial number handy.

If your dealer is no longer available, please go to our website: <http://wallensteinequipment.com> and click on the [Dealer Locator](#) to find the nearest dealer.

All information contained in this parts manual is current as per the revision date at the bottom of the page. Wallenstein reserves the right to change product specifications at any time without notice.

If your product specifications differ from those contained in this manual, contact Wallenstein for current information.

Reproduction of information in this parts manual is prohibited without prior written permission from Wallenstein Equipment Inc.

Wallenstein Equipment Inc. • © 2019

## WARNING!

**Refer to the operators manual for safe operation and maintenance.**

**Maintenance should be performed by trained personnel only.**

## Serial Number Location

Always provide the model and serial number of your Wallenstein product when ordering parts or requesting service or other information. This information is found on the product information plate as shown below.

**Record your product information here for future reference.**

**Model** \_\_\_\_\_

**Serial Number** \_\_\_\_\_

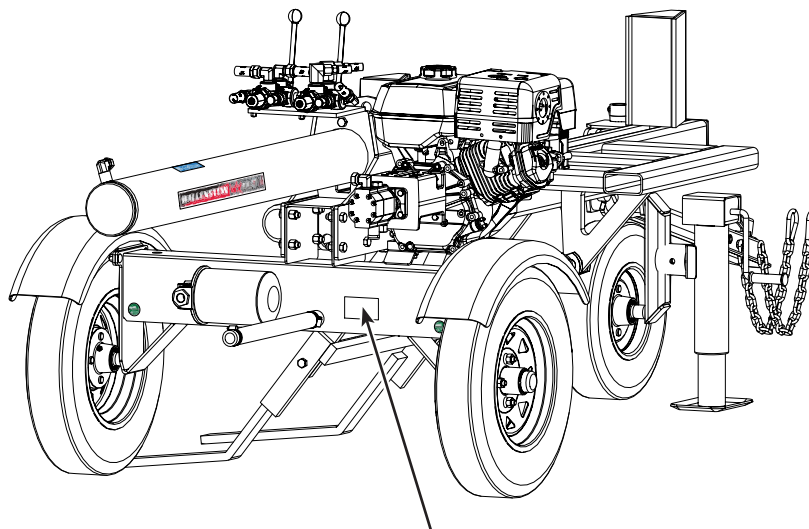

**Product Information Plate**

[www.wallensteinequipment.com](http://www.wallensteinequipment.com)

## Contents

<b>Main Parts .....</b>	<b>4</b>
<b>Tank and Trailer .....</b>	<b>5</b>
<b>Hitch &amp; Tongue .....</b>	<b>6</b>
<b>Dual Jockey Jack Assembly .....</b>	<b>7</b>
<b>Sliding Wedge Assembly .....</b>	<b>8</b>
<b>Hub Assembly .....</b>	<b>8</b>
<b>Engine and Hydraulics Assembly .....</b>	<b>9</b>
<b>Sliding Wedge Cylinder .....</b>	<b>10</b>
<b>Lift Shelf Cylinder .....</b>	<b>10</b>
<b>Valve Assembly .....</b>	<b>11</b>
<b>Z56209 Service Kits .....</b>	<b>11</b>
<b>Z56211 Service Kits .....</b>	<b>11</b>
<b>Hydraulic Circuit .....</b>	<b>12</b>
<b>Decal Layout .....</b>	<b>13</b>
<b>Accessories .....</b>	<b>14</b>
<b>Common Bolt Torque Values .....</b>	<b>15</b>
<b>Hydraulic Fitting Torque Values .....</b>	<b>16</b>
<b>Wheel Lug Torque Values .....</b>	<b>16</b>

Main Parts

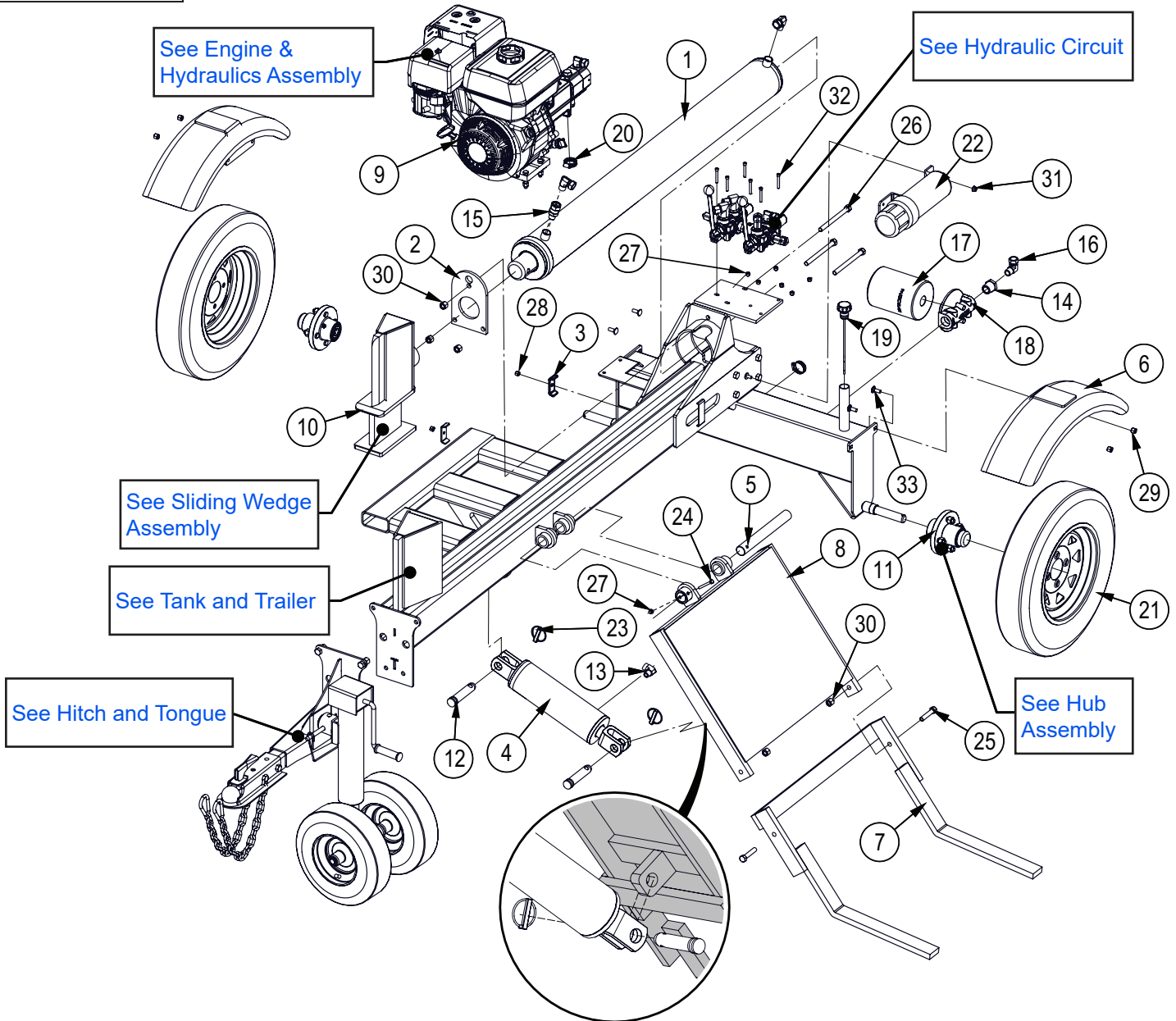

Item No.	Part No.	Description	Qty
1	2013C301	Cylinder, 4-1/2 x 48" x 2-1/2	1
2	2032S213	Plate, Cylinder Retaining	1
3	2054L412	Clamp, Two Hose	2
4	2058C801	Cylinder, 3-1/2 x 8 X 1-1/2	1
5	2058M815	Pin, Shelf Pivot	1
6	2058W811	Fender	2
7	2060W010	Log Arm	1
8	2060W013	Lift Shelf	1
9	2061A103	Assy, 9hp Engine to 16gpm Pump	1
10	2032A202	Wedge, Large Sliding Assy	1
11	Z91202	Idler Hub Assy, 1000lbs x 4on4" x 1"	2
12	Z11141	Toplink Pin, 1" x 3-3/16" MOD	2
13	Z51135	Elbow 90, MP x FP 0606	1
14	Z51223	Straight, MP x FP 1608	1
15	Z51312	Straight, MP x FPX 0808	1
16	Z51331	Elbow 90, MP x FPX 0808	3
17	Z55303	Particulate Filter, FP16	1

Item No.	Part No.	Description	Qty
18	Z55304	Filter Cap, MP16 x FP16	1
19	Z55404	Vented Plug Dipstick x 9"	1
20	Z79401	Hose Clamp, SAE #16 (1-1/2")	2
21	Z91302	5.30-12 LRB SportTrail 4on4"	2
22	Z96503	Manual Tube, 3-1/2" Short	1
23	Z12140	Lynch Pin, 7/16"	2
24	Z71122	Hex Bolt, 1/4NC x 2-1/4"	1
25	Z71525	Hex Bolt, 1/2NC x 2-1/2	2
26	Z71560	Hex Bolt, 1/2NC x 6"	3
27	Z72211	Hex Lock Nut, 1/4NC	7
28	Z72221	Hex Lock Nut, 5/16NC	2
29	Z72231	Hex Lock Nut, 3/8NC	4
30	Z72251	Hex Lock Nut, 1/2NC	5
31	Z72521	Serrated Flange Locknut, 5/16NC	1
32	Z75114	SHCS, 1/4NC x 1-3/4"	6
33	Z76231	Carriage Bolt, 3/8NC x 1"	4

**Tank and Trailer**

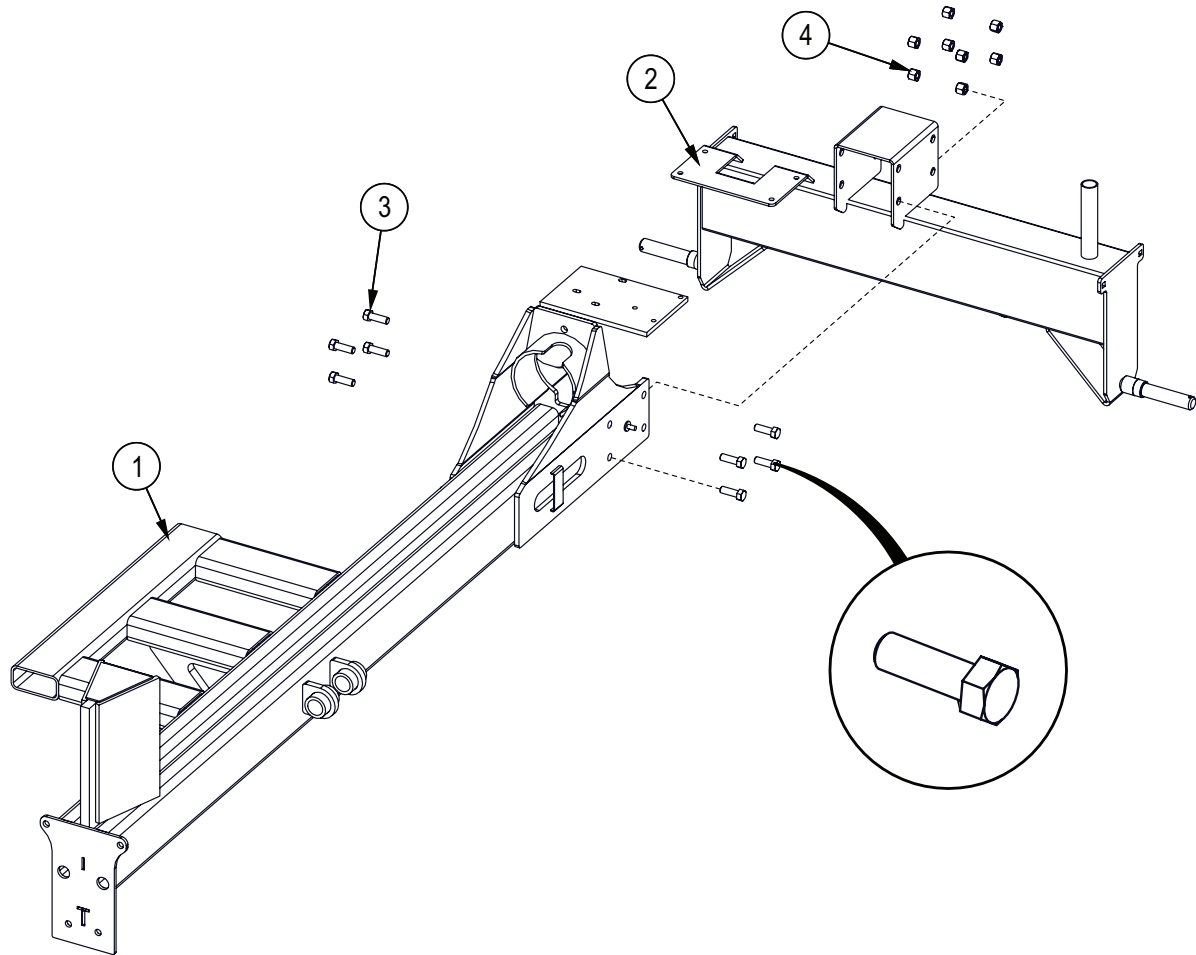

Item No.	Part No.	Description	Qty
1	2060W021	Main Trailer	1
2	2060W024	WX960 Tank	1
3	Z71515	Hex Bolt, 1/2NC x 1-1/2"	8
4	Z72251	Hex Lock Nut, 1/2NC	8

Hitch & Tongue

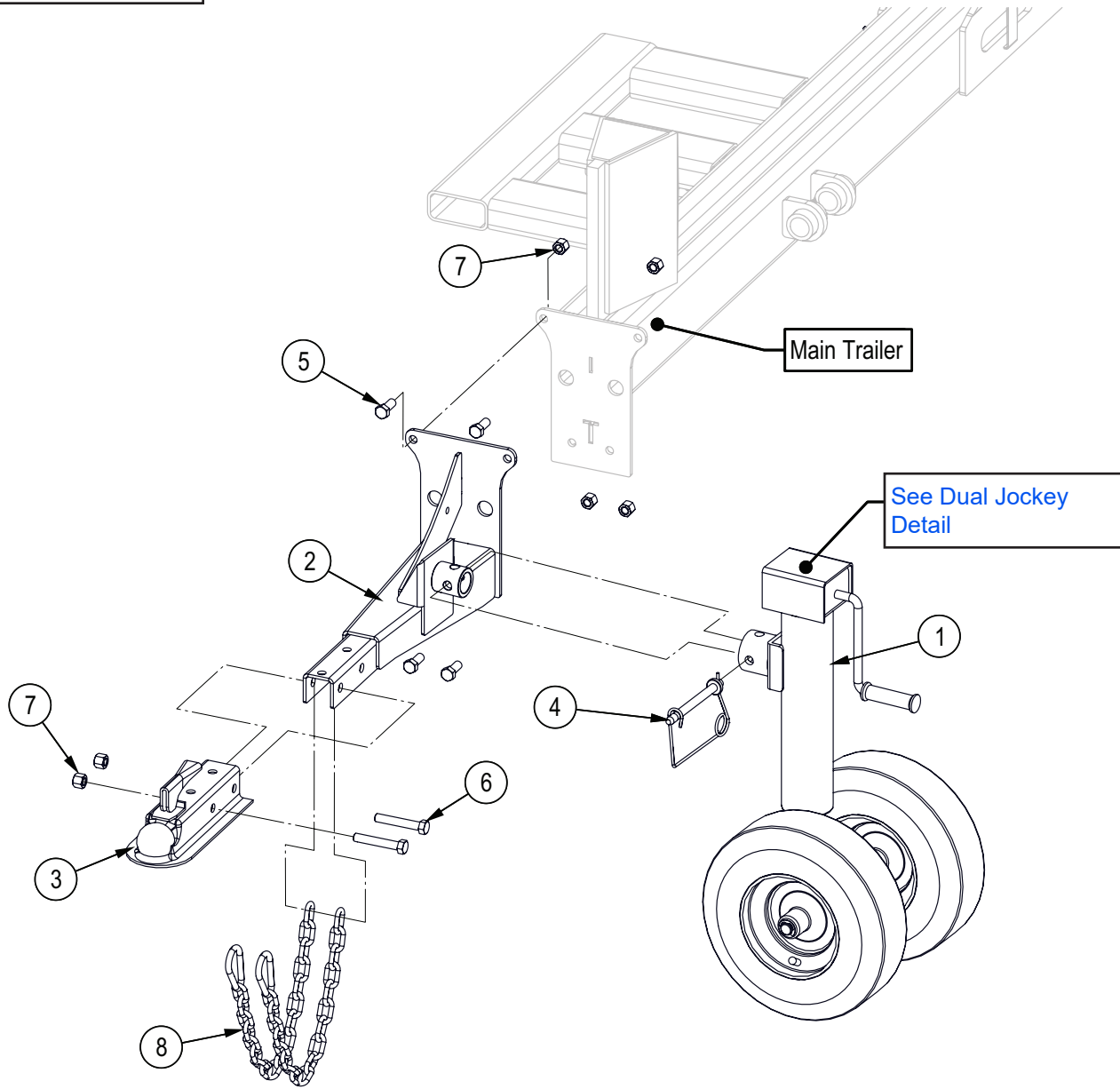

Item No.	Part No.	Description	Qty
1	2060A001	Dual Jockey Jack	1
2	2060W020	Trailer Tongue	1
3	Z91614	Hitch Coupler, 2" Ball x 2" x 3500lbs	1
4	Z12441	Snap Lock Pin, 1/2" x 4-1/2"	1
5	Z71512	Hex Bolt, 1/2NC x 1-1/4"	4
6	Z71530	Hex Bolt, 1/2NC x 3"	2
7	Z72251	Hex Lock Nut, 1/2NC	6
8	Z92303	Safety Chain, 1/4" x 2ft with Snap	2

## Dual Jockey Jack Assembly

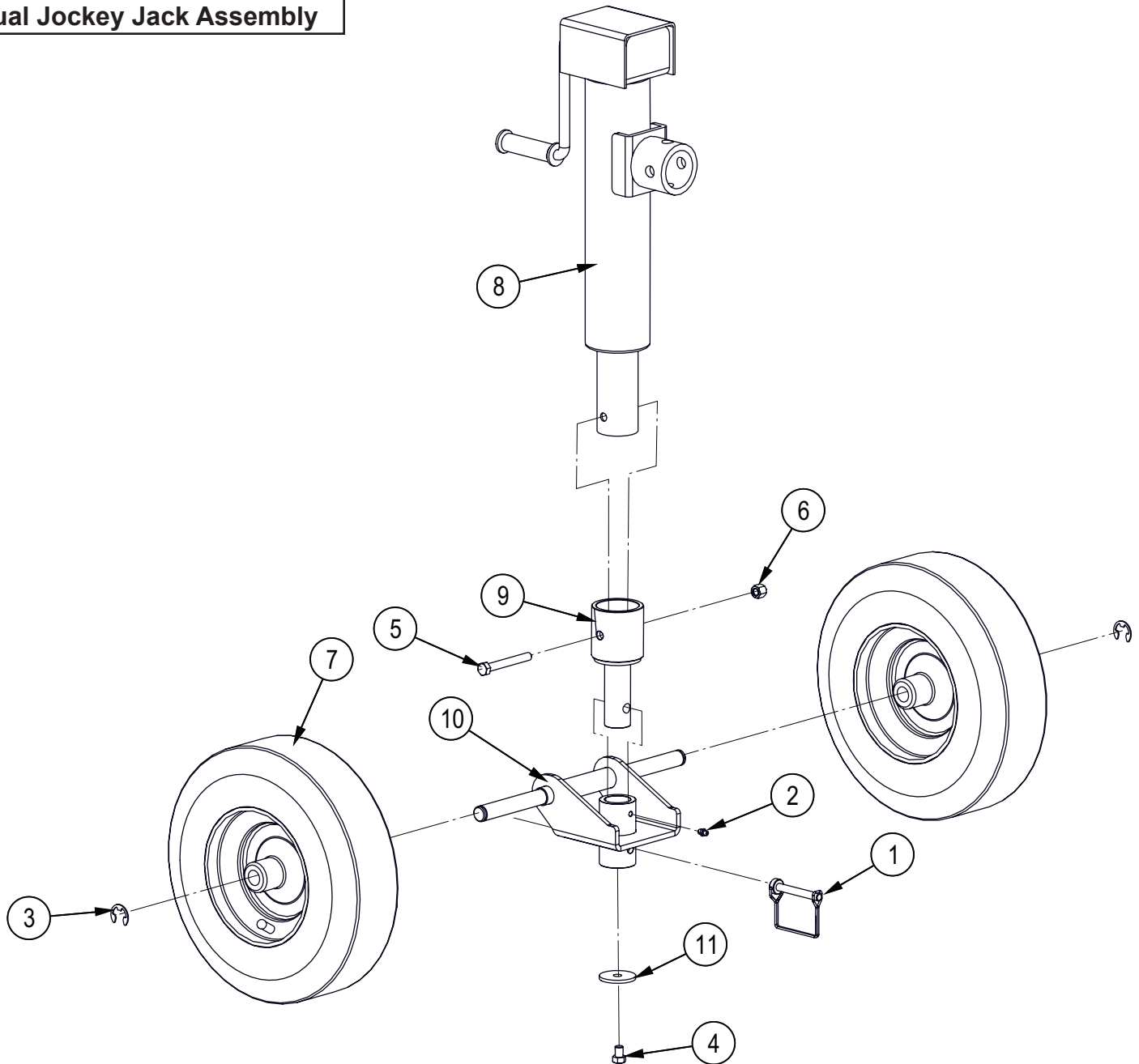

Item No.	Part No.	Description	Qty
1	Z12432	Snap Lock Pin, 3/8" x 2-1/2"	1
2	Z29202	Grease Fitting, 1/4NF	1
3	Z46203	E-Style Retaining Ring, 3/4"	2
4	Z71305	Hex Bolt, 3/8NC x 1/2"	1
5	Z71330	Hex Bolt, 3/8NC x 3"	1
6	Z72231	Hex Lock Nut, 3/8NC	1
7	Z91311	4.10-6NHS 2PR 290lbs Sawtooth x 3/4"	2
8	Z91515	Trailer Jack, Side Wind x 2000lbs No Foot	1
9	2060W022	Jockey Pivot Foot	1
10	2060W023	Dual Jockey Axle	1
11	2060L008	Washer, 3/8" Extra Wide	1

**Sliding Wedge Assembly**

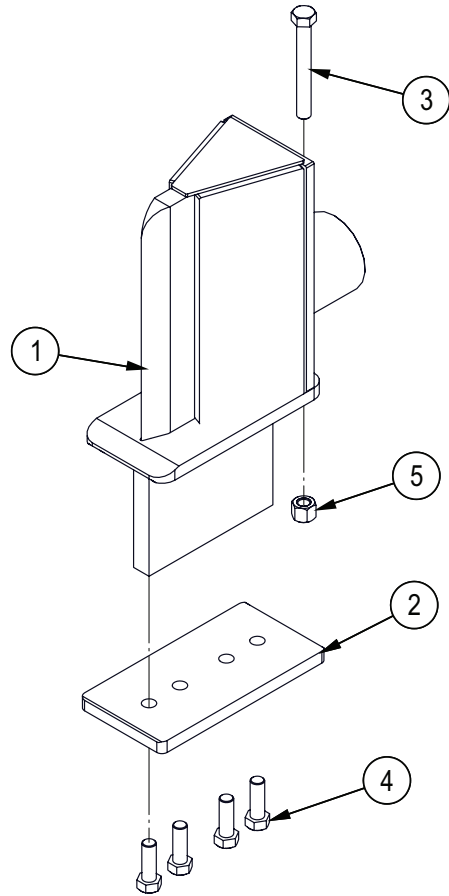

**2032A202 SLIDING WEDGE PARTS**

Item No.	Part No.	Description	Qty
1	2032W203	Wedge, Large Sliding	1
2	2014S414	Plate, Sliding Wedge Capture	1
3	Z71537	Hex Bolt, 1/2NC x 3-3/4"	1
4	Z71576G8	Hex Bolt, 1/2NF x 1-1/2" G8	4
5	Z72251	Hex Lock Nut, 1/2NC	1

**Hub Assembly**

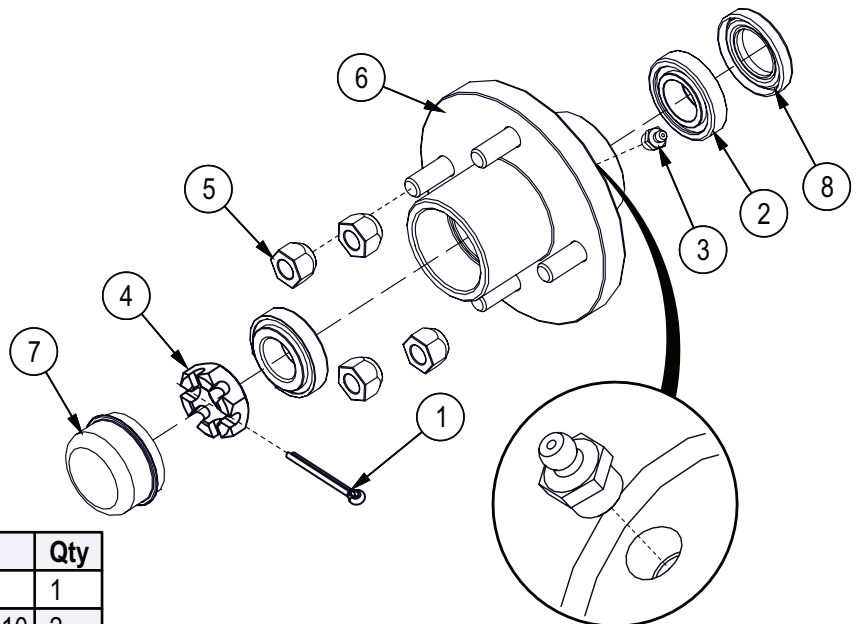

Item No.	Part No.	Description	Qty
1	Z12321	Cotter Pin, 3/16" x 1-3/4"	1
2	Z23201	Roller Bearing, L44643 L44610	2
3	Z29201	Grease Fitting, MP02	1
4	Z72691	Castle Nut, 1NF x 9/16" Thick	1
5	Z72931	Lug Nut, 1/2NF	4
6	Z91201	Hub, 1000lbs x 4on4	1
7	Z91801	Dust Cap, 1.98 Bore	1
8	Z28301	Double Lip Seal, 1-1/4"	1



**Engine and Hydraulics Assembly**

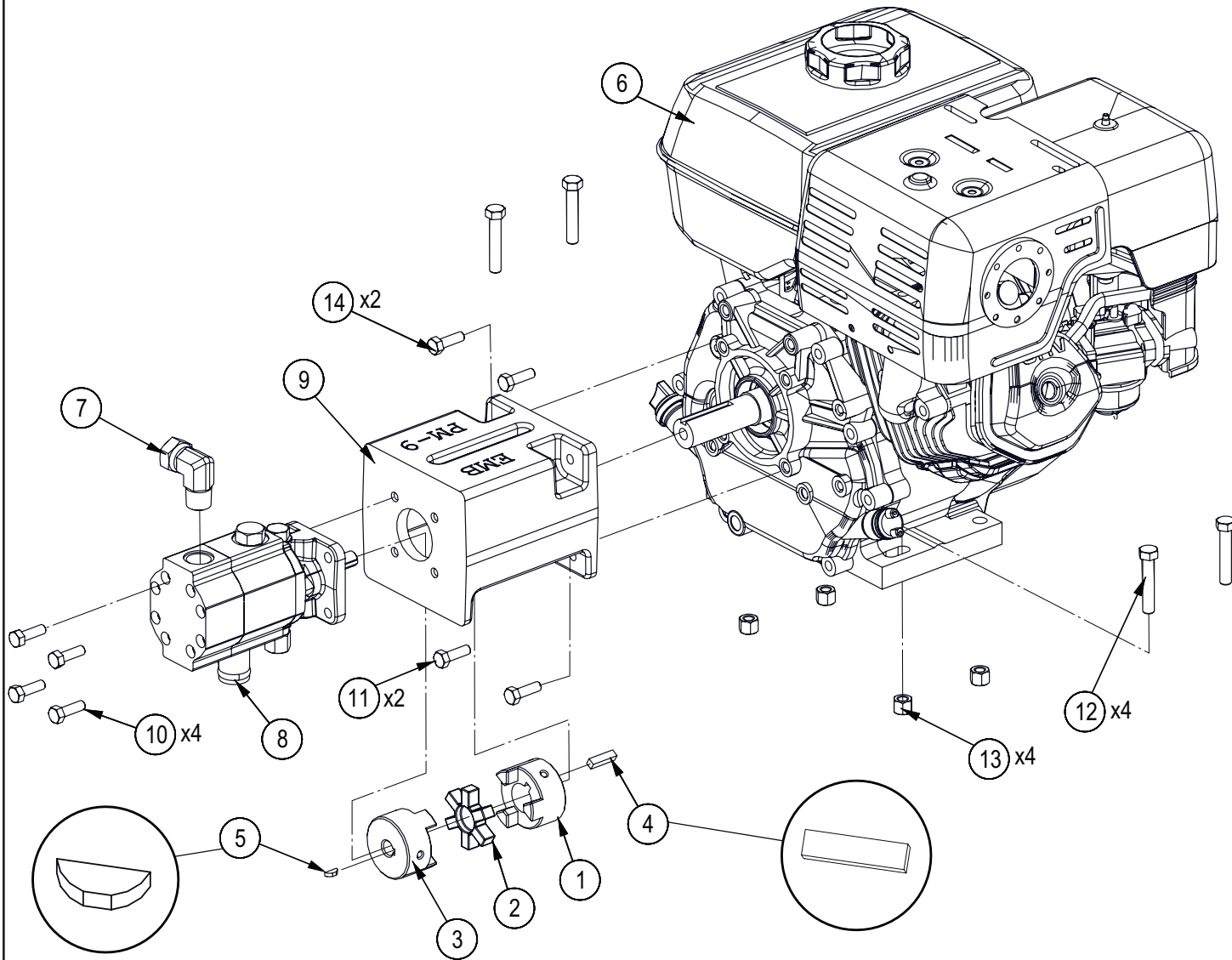

Item No.	Part No.	Description	Qty
1	Z46404	Shaft Coupling, L095 x 1"	1
2	Z46405	Spider, L095	1
3	Z46409	Shaft Coupling, L095 x 1/2"	1
4	Z46533	Key, 1/4" x 1/4" x 1"	1
5	Z46592	Woodruff Key, 1/8" x 1/2"	1
6	Z47135	Honda GX270UTQH6, Rope	1
7	Z51331	Elbow 90, MP x FPX 0808	1
8	Z53205	Two-Stage Pump, 16GPM	1
9	Z53802	Pump Mount, PM-9	1
10	Z71207	Hex Bolt, 5/16NC x 3/4"	4
11	Z71274	Hex Bolt, 5/16NF x 1"	2
12	Z71320	Hex Bolt, 3/8NC x 2"	4
13	Z72231	Hex Lock Nut, 3/8NC	4
14	Z71273	Hex Bolt, 5/16NF x 3/4"	2

**Sliding Wedge Cylinder**

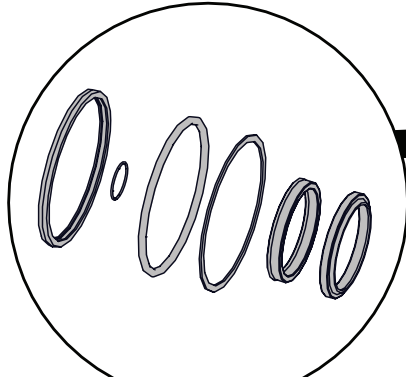

Seal Kit #SLK4525

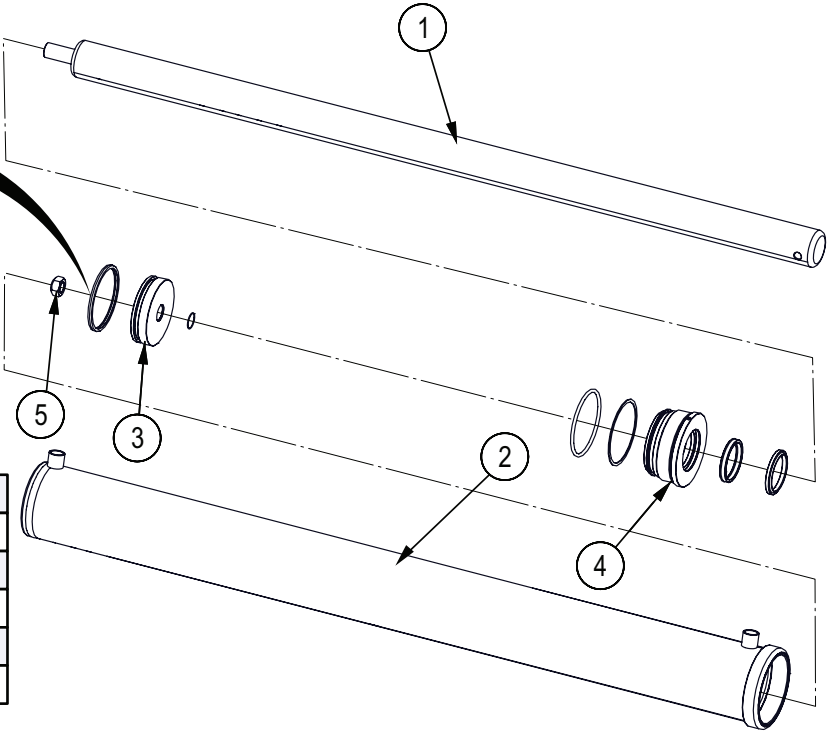

Item No.	Part No.	Description	Qty
1	2013C3012	Rod, 2-1/2 x 1	1
2	2013C3014	Barrel, 4-1/2"	1
3	P100-450SP	Piston, 4-1/2" Bore	1
4	G450-250S	Gland, 4-1/2" x 2-1/2"	1
5	Z72276	Hex Top-lock Nut, 3/4NF	1

**Lift Shelf Cylinder**

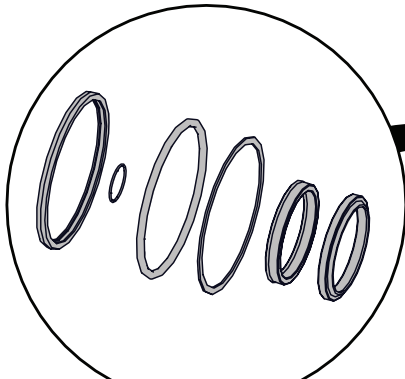

Seal Kit #SLK3515

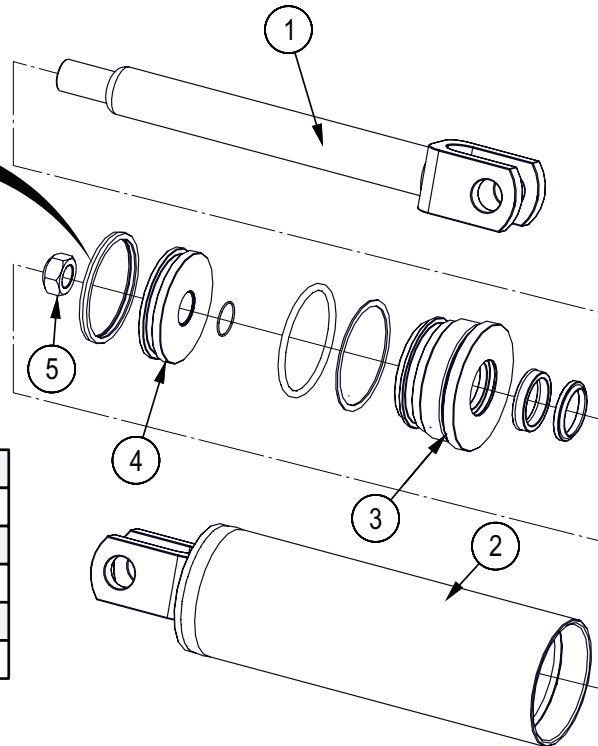

Item No.	Part No.	Description	Qty
1	2058C8013	Rod, 1-1/2 x 1	1
2	2058C8014	Barrel, 3-1/2"	1
3	G350-150S	Gland, 3-1/2" x 1-1/2"	1
4	P100-350SP	Piston, 3-1/2" Bore	1
5	Z72276	Hex Top-lock Nut, 3/4NF	1

**Valve Assembly**

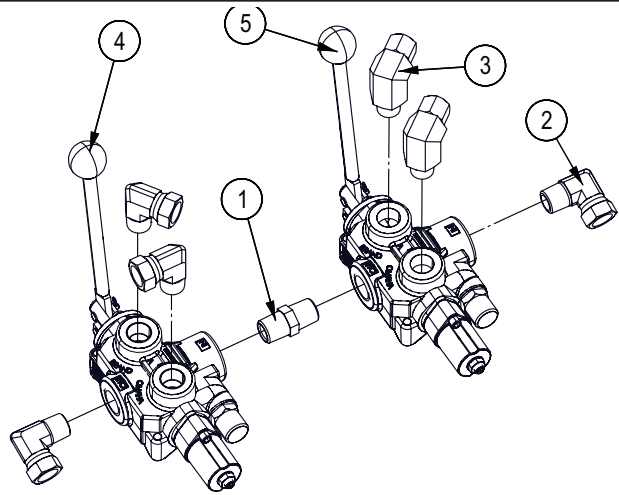

Item No.	Part No.	Description	Qty
1	Z51122	Straight, MP x MP 0808	1
2	Z51331	Elbow 90, MP x FPX 0808	4
3	Z51332	Elbow 90, MP x FPX 0806	2
4	Z56209	Single Spool Valve, OC Tandem SCDK x 18GPM	1
5	Z56211	Single Spool Valve, OC Tandem SC x 18GPM	1

**Z56209 Service Kits**

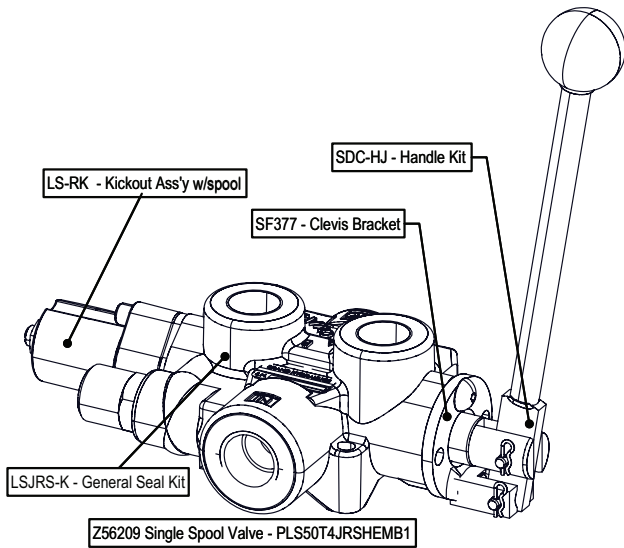

**Z56211 Service Kits**

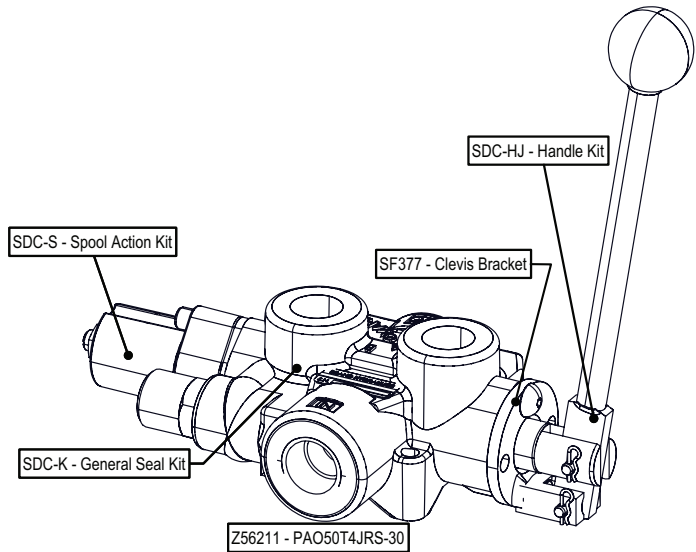

Hydraulic Circuit

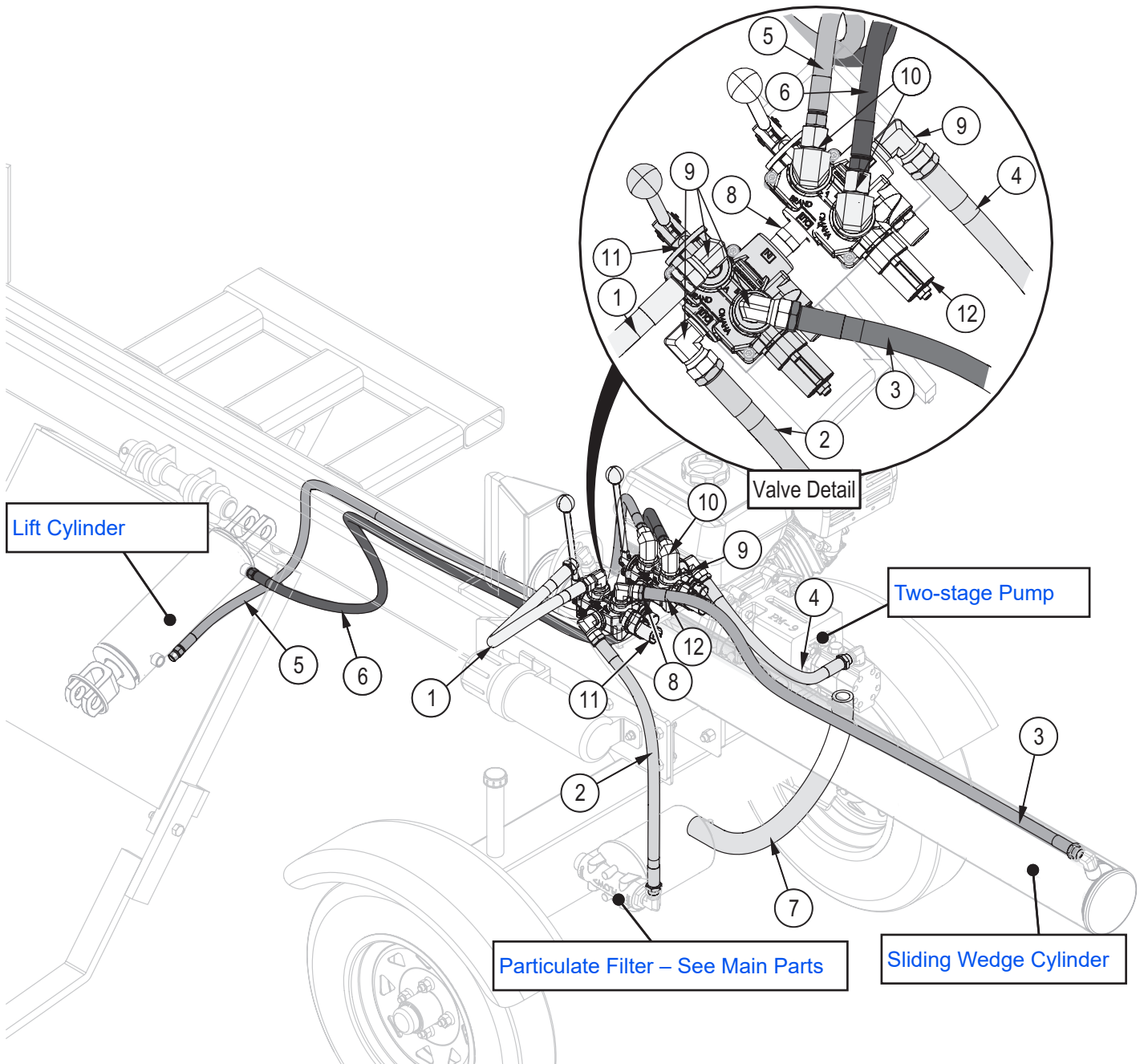

Item No.	Part No.	Description	Qty
1	2060F001	1/2" Hose, MP08 x MP08 x 21"	1
2	2060F002	1/2" Hose, MP08 x MP08 x 19.5"	1
3	2060F003	1/2" Hose, MP08 x MP08 x 45"	1
4	2060F004	1/2" Hose, MP08 x MP08 x 13"	1
5	2060F005	3/8" Hose, MP06 x MP06 x 70"	1
6	2060F006	3/8" Hose, MP06 x MP06 x 63"	1
7	2060F007	Suction Hose, 1" x 18"	1
8	Z51122	Straight, MP x MP 0808	1
9	Z51331	Elbow 90, MP x FPX 0808	4
10	Z51332	Elbow 90, MP x FPX 0806	2
11	Z56209	Single Spool Valve, OC Tandem SCDK x 18GPM	1
12	Z56211	Single Spool Valve, OC Tandem SC x 18GPM	1

### Decal Layout

**IMPORTANT!** If parts are replaced that have safety signs on them, new signs must be applied. Safety signs must always be replaced if they become damaged, are removed, or become illegible.

Safety signs are included in the product decal kit available from your authorized dealer. Decals are not available separately.

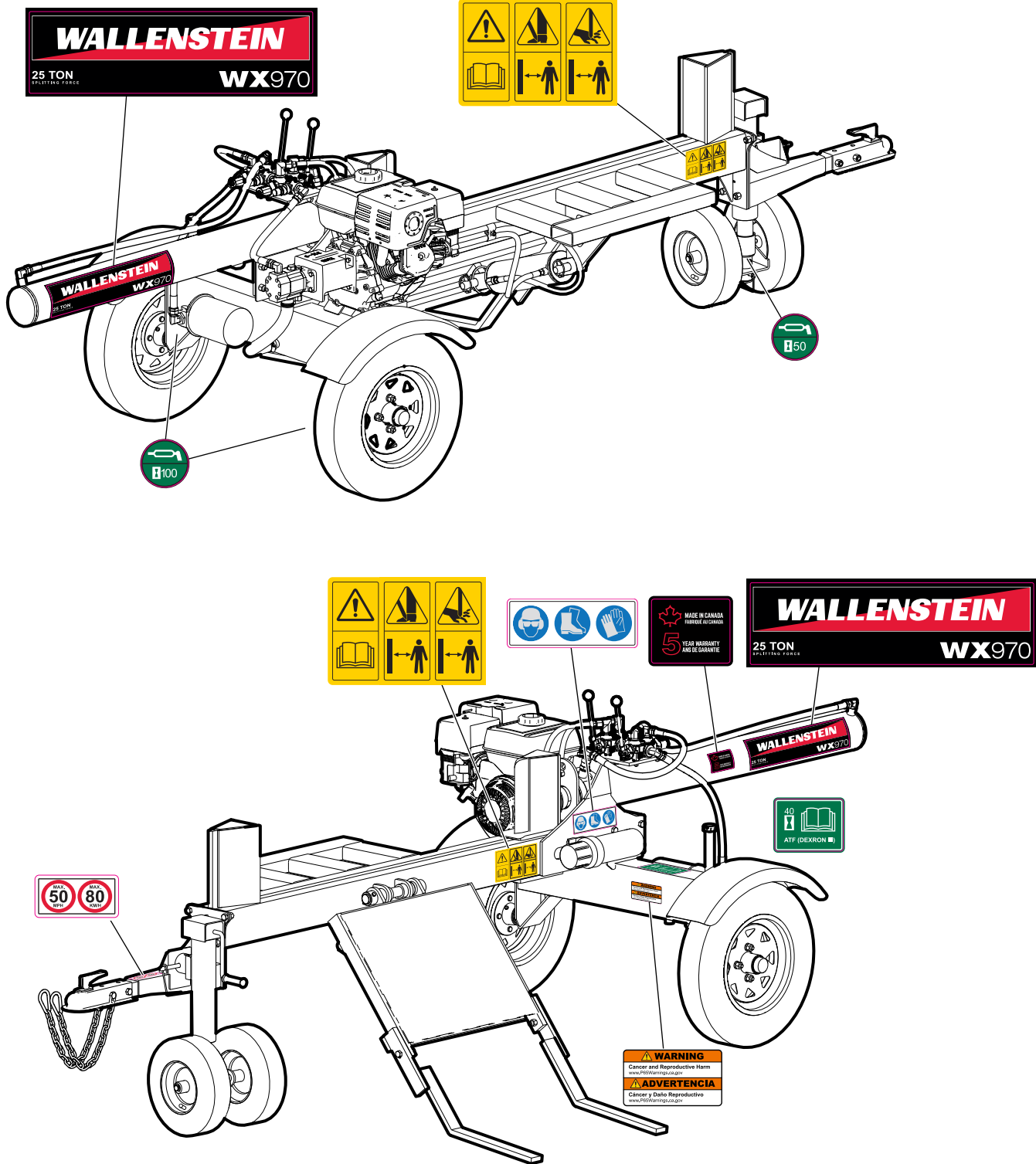

**Accessories**

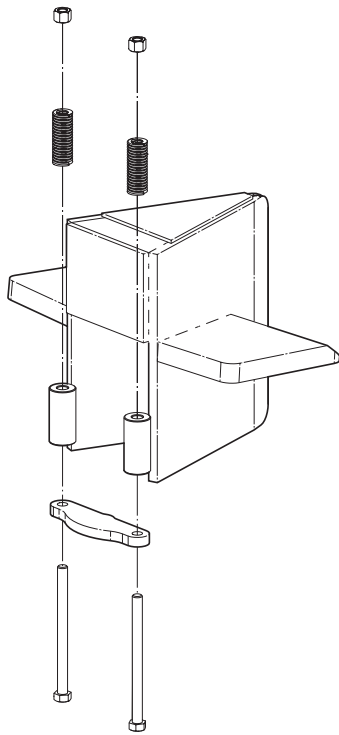

**4-Way Wedge – P/N 4130**

Boost productivity and make quick work out of logs by splitting four pieces at once.

Call your dealer for pricing and availability

## Common Bolt Torque Values

### Checking Bolt Torque

The tables shown give correct torque values for various bolts and capscrews. Tighten all bolts to the torque values specified in the table, unless indicated otherwise. Check tightness of bolts periodically.

**IMPORTANT!** If replacing hardware, use fasteners of the same grade.

**IMPORTANT!** Torque figures indicated in the table are for non-greased or non-oiled threads. Do not grease or oil threads unless indicated otherwise. When using a thread locker, increase torque values by 5%.

 **NOTE:** Bolt grades are identified by their head markings.

### Imperial Bolt Torque Specifications

Bolt Diameter	Torque Value					
	SAE Gr. 2		SAE Gr. 5		SAE Gr. 8	
	lbf·ft	N·m	lbf·ft	N·m	lbf·ft	N·m
1/4"	6	8	9	12	12	17
5/16"	10	13	19	25	27	36
3/8"	20	27	33	45	45	63
7/16"	30	41	53	72	75	100
1/2"	45	61	80	110	115	155
9/16"	60	95	115	155	165	220
5/8"	95	128	160	215	220	305
3/4"	165	225	290	390	400	540
7/8"	170	230	420	570	650	880
1"	225	345	630	850	970	1320



SAE Gr. 2



SAE Gr. 5



SAE Gr. 8

### Metric Bolt Torque Specifications

Bolt Diameter	Torque Value			
	Gr. 8.8		Gr. 10.9	
	lbf·ft	N·m	lbf·ft	N·m
M3	0.4	0.5	1.3	1.8
M4	2.2	3	3.3	4.5
M6	7	10	11	15
M8	18	25	26	35
M10	37	50	52	70
M12	66	90	92	125
M14	83	112	116	158
M16	166	225	229	310
M20	321	435	450	610
M30	1,103	1 495	1,550	2 100



8.8



10.9

### Hydraulic Fitting Torque Values

#### Tightening Flare Type Tube Fittings

1. Check flare and flare seat for defects that might cause leakage.
2. Align tube with fitting before tightening.
3. Hand-tighten swivel nut until snug.
4. To prevent twisting the tube, use two wrenches. Place one wrench on the connector body and tighten the swivel nut with the second. Torque to values shown.

If a torque wrench is not available, use the FFFT (Flats From Finger Tight) method.

Hydraulic Fitting Torque					
Tube Size OD	Hex Size Across Flats	Torque value		Flats From Finger Tight	
		lbf•ft	N•m	Flats	Turns
3/16	7/16	6	8	2	1/6
1/4	9/16	11–12	15–17	2	1/6
5/16	5/8	14–16	19–22	2	1/6
3/8	11/16	20–22	27–30	1-1/4	1/6
1/2	7/8	44–48	59–65	1	1/6
5/8	1	50–58	68–79	1	1/6
3/4	1-1/4	79–88	107–119	1	1/8
1	1-5/8	117–125	158–170	1	1/8

Values shown are for non-lubricated connections.

### Wheel Lug Torque Values

It is extremely important safety procedure to apply and maintain proper wheel mounting torque on your trailer axle. Torque wrenches are the best method to assure the proper amount of torque is being applied to a fastener.

Wheel lugs should be torqued before first road use and after each wheel removal. Check and re torque after the first 10 miles (16 km), 25 miles (40 km), and again at 50 miles (80 km). Check periodically thereafter.

**NOTE:** *Wheel lugs must be applied and maintained at the proper torque levels to prevent loose wheels, broken studs, and possible dangerous separation of wheels from your axle.*

- Start all lugs by hand to prevent cross threading.
- Tighten lugs in sequence, per wheel lug torque sequence chart.
- The tightening of the fasteners should be done in stages. Following the recommended sequence, tighten fasteners per wheel torque requirements chart.

Wheel Lug Nut Torque				
Wheel Size	Units	1st Stage	2nd Stage	3rd Stage
8"	lbf•ft N•m	12–20 16–26	30–35 39–45.5	45–55 58.5–71.5
12"	lbf•ft N•m	20–25 26–32.5	35–40 45.5–52	50–60 65–78
13"	lbf•ft N•m	20–25 26–32.5	35–40 45.5–52	50–60 65–78
14"	lbf•ft N•m	20–25 26–32.5	50–60 65–78	90–120 117–156
15"	lbf•ft N•m	20–25 26–32.5	50–60 65–78	90–120 117–156
16"	lbf•ft N•m	20–25 26–32.5	50–60 65–78	90–120 117–156

Wheel Lug Torque Pattern

