

OPERATOR'S MANUAL

BXMC3409B: serial number up to 1100779

BXMC34 Series **Cart Chipper-Shredder**

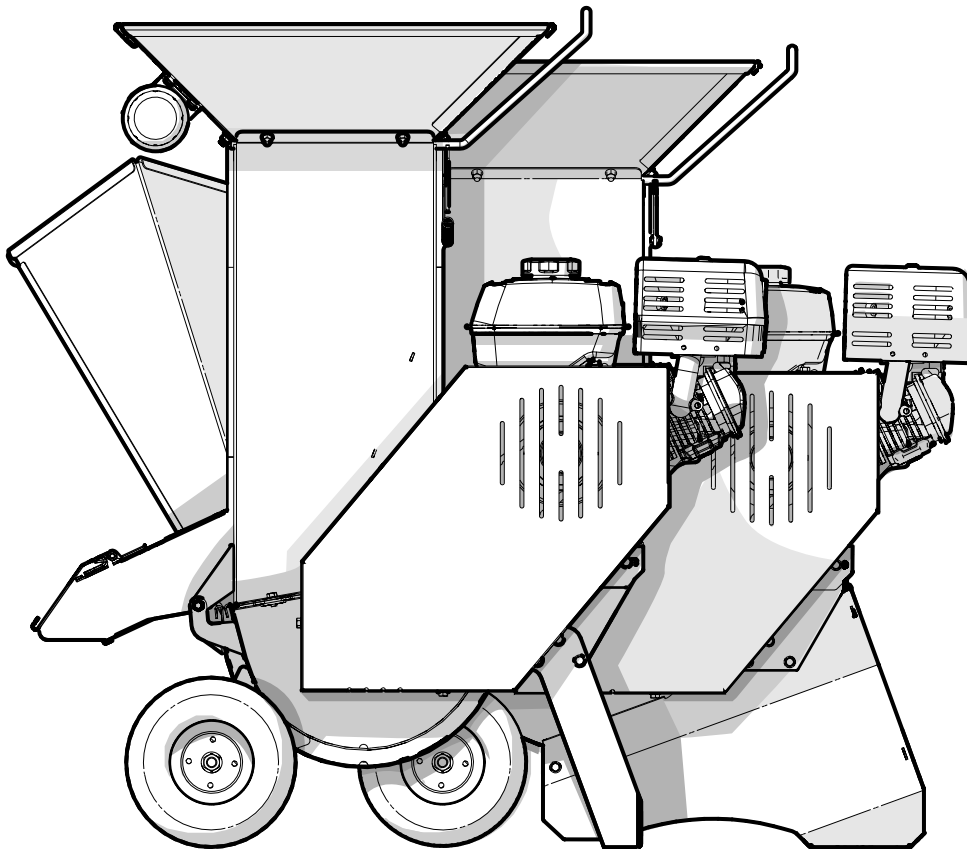

Rev October-2021

Part Number: Z97113_En

WALLENSTEIN

1. Foreword

1.1 Introduction

Congratulations on choosing a Wallenstein BXMC Cart Chipper-Shredder!

This manual covers the following models:

Model	Discharge Type
BXMC34S BXMC3409S	Bottom Discharge
BXMC34B BXMC3409B	Blower Discharge

These machines are designed and manufactured to chip and shred wood in a fast and efficient manner for homeowners and landscapers.

- The BXMC Series of chipper-shredders feature a large shredder feed hopper. The shredder chamber contains three sets of four swinging knives for mulching leaves and brush up to 3/4" (19 mm) in diameter.
- The chipper portion of the BXMC Series feature a large rotor with two knives. The angled chipper hopper can accept wood material up to 3" (75 mm) in diameter.
- A gas engine and a V-belt drive system power the rotor. The BXMC brake / clutch system is designed to provide longer belt life, and braking clutch capability that quickly and safely stops the rotor when the drive is disengaged. The system provides a positive, fail-safe brake that meets current European and US safety requirements.
- The BXMC34 models feature a Honda® GX200 engine with 5.5 hp (4.1 kW) @ 3600 rpm.
- The BXMC3409 models feature a Honda® GX270 engine with 8.5 hp (6.3 kW) @ 3600 rpm.
- Chipper-Shredder 'S' models direct the wood mulch into a discharge cage under the motor. The machine must be moved periodically as mulch builds up underneath.
- Chipper-Shredder 'B' models direct wood mulch out a discharge chute. The (included) mulch bag can be attached to the chute. The (included) Jockey wheel can be used to move the chipper around the site.

Review all safety, operation and maintenance information contained in this manual.

Keep this manual handy for reference. Pass it on to new operators or owners. Call your Wallenstein dealer or the Distributor if you need assistance, information or additional copies of this manual.



WARNING!

Do not attempt to start or operate the machine without thoroughly reviewing this manual for safe and proper operation.

Always keep this manual with the machine.

W034

Wallenstein Equipment Inc. • © 2021. All rights reserved.

No part of this work may be copied, reproduced, replaced, distributed, published, displayed, modified, or transferred in any form or by any means except with the prior permission of Wallenstein Equipment Inc.

Table of Contents

1. Foreword	2	7. Service and Maintenance.....	33
1.1 Introduction.....	2	7.1 Fluids and Lubricants	33
1.2 Delivery Inspection Report.....	4	7.2 Maintenance Schedule	33
1.3 Serial Number Location	5	7.3 Grease Points.....	34
1.4 Types of Decals on the Machine	6	7.4 Drive Belt Replacement.....	35
2. Safety	7	7.5 Drive Belt, Tensioning.....	36
2.1 Safety Alert Symbol.....	7	7.6 Drive Belt Alignment.....	36
1.5 Signal Words.....	7	7.7 Rotor Blades – Checking	38
2.2 Why is SAFETY important?	8	7.8 Rotor Blades – Changing.....	39
2.3 Safety Rules.....	8	7.9 Ledger Knife – Clearance.....	39
2.4 Equipment Safety Guidelines	8	7.10 Ledger Knife – Adjusting.....	39
2.5 Safety Training	9	7.11 Shredder Knives – Changing.....	40
2.6 Be Prepared	9	7.12 Chop Block	41
2.7 Operating Safety.....	9	7.13 Twig Breaker	41
2.8 Transport Safety.....	10	7.14 Mulching Screen	42
2.9 Refueling Safety	10	8. Troubleshooting.....	43
2.10 Gas Engine Safety	10	9. Specifications	45
2.11 Maintenance Safety.....	11	9.1 Machine Specifications.....	45
2.12 Sign-Off Form	12	9.2 Common Bolt Torque Values	46
3. Safety Signs	13	10. Accessories.....	47
3.1 Safety Sign Locations.....	13	10.1 Warranty.....	48
3.2 Safety Sign Explanations	14	11. Alphabetical Index	49
3.3 Replace Damaged Safety Signs	15		
4. Familiarization.....	16		
4.1 To the New Operator	16		
4.2 Machine Components.....	16		
5. Controls	21		
5.1 Engine Controls.....	21		
5.2 Shredder Hopper Flap.....	22		
5.3 Clutch Actuator Lever	23		
6. Operation.....	24		
6.1 Before Starting the Engine	24		
6.2 Pre-operation Checklist	25		
6.3 Machine Break-in Period.....	25		
6.4 Fuel Level Check	25		
6.5 Engine Oil Level Check.....	26		
6.6 Machine Set-up.....	26		
6.7 Starting the Engine	26		
6.8 Stopping Procedure.....	27		
6.9 Stopping in an Emergency.....	27		
6.10 Engaging Drive.....	28		
6.11 Chipping Operation.....	28		
6.12 Shredding Operation.....	29		
6.13 Moving the Chipper	29		
6.14 Mulch Collector Bag	30		
6.15 Jockey Wheel.....	31		
6.16 Unplugging the Chipper	31		
6.17 Placing Chipper in Storage.....	32		

1.2 Delivery Inspection Report

This form must be filled out by the dealer at the time of delivery, then signed by the dealer and customer.

Wallenstein BXMC34 Series Cart Chipper-shredder

To activate warranty, register your product at:
www.wallensteinequipment.com

The product manuals have been received by me and I have been thoroughly instructed as to care, adjustments, safe operation, and applicable warranty policy.

I have thoroughly instructed the buyer on the equipment care, adjustments, safe operation and applicable warranty policy and reviewed the manuals.

Customer

Dealer

Address

Address

City, State/Province, ZIP/Postal Code

City, State/Province, ZIP/Postal Code

()

Phone Number

()

Phone Number

Contact Name

Model

Serial Number

Delivery date

Dealer Inspection Checklist

- _____ Rotor turns freely and the blade clearance is correct.
- _____ All cutting edges are sharp and in good condition.
- _____ Discharge chute and deflector move freely.
- _____ Drive lever functions correctly.
- _____ Drivebelt tension and alignment is correct
- _____ Engine oil level is correct
- _____ All fasteners are tightened to the correct torque.
- _____ Rotor bearings are lubricated.
- _____ Wheels inspected and tire pressure checked.
- _____ Operator's Manual is in the storage tube.

Safety Checks

- _____ All safety sign decals are applied and legible.
- _____ All guards, shields, and covers are installed and secure.
- _____ Operating and safety instructions were reviewed.

1.3 Serial Number Location

Always provide the serial number of your Wallenstein product when ordering parts or requesting service or other information.

The Serial Number Plate location is shown in the illustration. **Please record the product Model and Serial Number in the space provided below for easy reference.**

Record Product Information Here	
Model:	
Serial Number:	

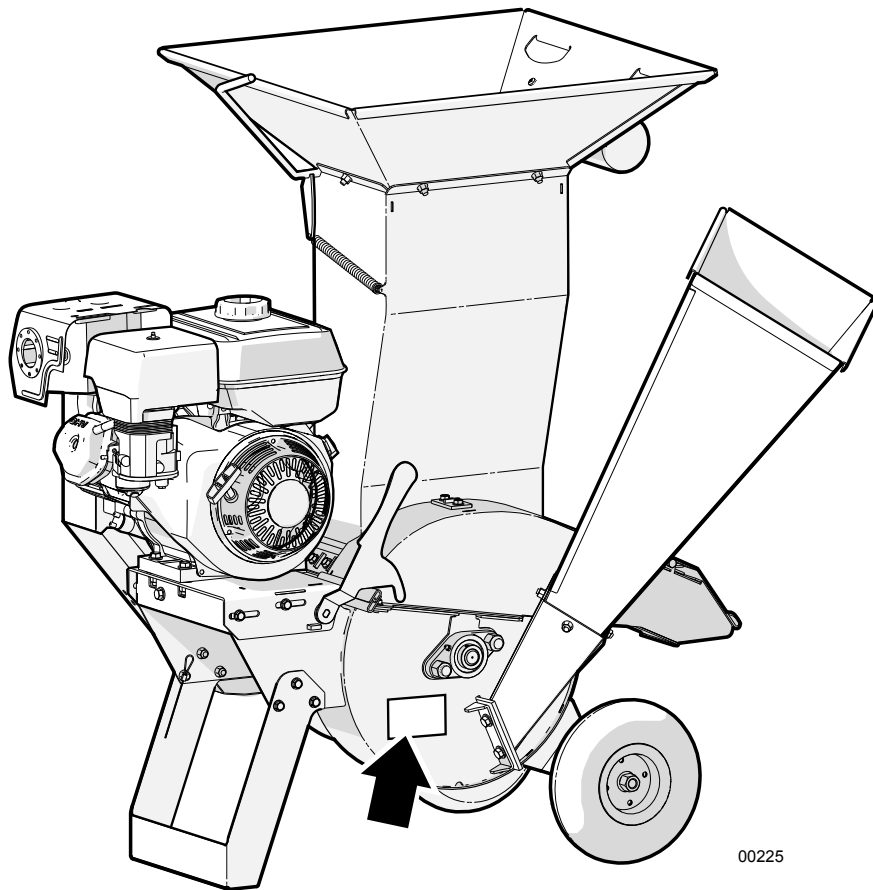
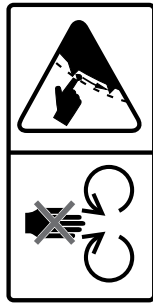

Fig. 1 – Serial Number Plate Location (Typical)

1.4 Types of Decals on the Machine

When getting familiar with the Wallenstein product, notice that there are numerous decals located on the machine. There are different types of decals for safety, information, and product identification. The following section explains what they are for and how to read them.

Safety Sign Decals have a yellow background and are generally two panel. They can be either vertical or horizontal.



Safety Notice Decals are pictorial with a blue background and generally rectangular with single or multiple symbols. This decal informs the operator of what Personal Protective Equipment is required for safe operation.



Informative Decals are generally pictorial with a white background and can vary in the number of panels. This type of decal explains how a control works.

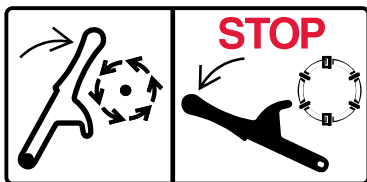

Product Decals indicate machine model and serial number, and other important information.

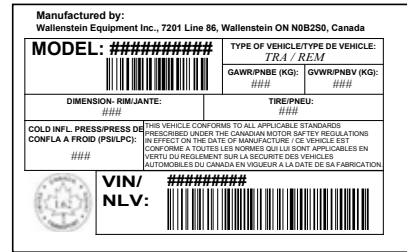

Maintenance Decals have a green background. The decal indicates a maintenance procedure and frequency interval.

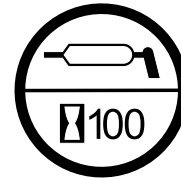

See the section on safety signs for safety decal definitions. For a complete illustration of decals and decal locations, download the parts manual for your model product at www.wallensteinequipment.com.

2. Safety

2.1 Safety Alert Symbol

This Symbol means:

**ATTENTION! BE ALERT!
YOUR SAFETY IS INVOLVED!**

The Safety Alert Symbol identifies important safety messages on the Wallenstein product and in the manual.

When you see this symbol, be alert to the possibility of personal injury or death! Follow the instructions in the safety message.



1.5 Signal Words

The signal words **DANGER**, **WARNING** and **CAUTION** determine the seriousness level of the warning messages in this manual. The appropriate signal word for each message in this manual has been selected using the following guidelines:

DANGER –

Indicates an imminently hazardous situation that, if not avoided, **will** result in death or serious injury. This signal word is to be limited to the most extreme situations typically for machine components which, for functional purposes, cannot be guarded.

WARNING –

Indicates a potentially hazardous situation that, if not avoided, **could** result in death or serious injury, and includes hazards that are exposed when guards are removed. It may also be used to alert against unsafe practices.

CAUTION –

Indicates a potentially hazardous situation that, if not avoided, **may** result in minor or moderate injury. It may also be used to alert against unsafe practices.

IMPORTANT – To avoid confusing equipment protection with personal safety messages, a signal word **IMPORTANT** indicates a situation that if not avoided, could result in damage to the machine.

2.2 Why is SAFETY important?

Three Big Reasons:

- Accidents Disable and Kill
- Accidents Cost
- Accidents Can Be Avoided



The policy of Wallenstein Equipment Inc. is to produce products that are safe and reliable. However, even when using well-engineered equipment, there is always an element of risk. To minimize the risks and always promote safety, this section of the operator's manual details safety rules that must always be followed and obeyed.

YOU are responsible for the SAFE operation and maintenance of your Wallenstein Wood Chipper. **YOU** must ensure that you and anyone else who is going to use, maintain or work around the wood chipper be familiar with the operating and maintenance procedures and related safety information contained in this manual. This manual provides good safety practices that should be followed while using the wood chipper.

Remember, **YOU** are the key to safety. Good safety practices not only protect you but also the people around you. Make these practices a working part of your safety program. Be certain that **EVERYONE** using this equipment is familiar with the recommended use and maintenance procedures and follows all the safety precautions.

Do not risk injury or death by ignoring good safety practices.

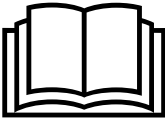
2.3 Safety Rules

- **DO** give operating instructions to operators or employees before allowing them to operate the machine.
- **DO** read and understand ALL Safety and Operating instructions in the manual and follow them. The most important safety device on this equipment is a SAFE operator. 
- **DO** review safety related items annually with all personnel who are operating the machine or performing maintenance.
- **DO** wear appropriate Personal Protective Equipment (PPE). The suggested equipment includes but is not limited to the following:
 - Hearing Protection
 - Protective glasses, goggles, or face shield

- **DO** have a first-aid kit available for use should the need arise.



- **DO** read and understand all safety signs located on the machine before operating, servicing, adjusting, or cleaning.
- **DO** inspect and secure all guards before starting.
- **DO** check input and discharge chutes, engine intake and exhaust. Make sure they are clear of debris prior to starting the machine.
- **DO** inspect and secure all guards before starting.
- **DO** have a fire extinguisher available for use should the need arise. Know how to use it.



- **DO NOT** touch hot engine parts, muffler cover, engine body, engine oil, and so on during operation or if the engine was recently shut off. Contact may cause burns.
- **DO NOT** expect a person who has not read and understood all operation and safety instructions to use the machine. An untrained operator is not qualified and is exposed to possible serious injury or death. It is the owner's responsibility to make sure to the operator has familiarity and understanding of the machine.
- **DO NOT** risk injury or death by ignoring good safety practices.
- **DO** think SAFETY! Work SAFELY!

2.4 Equipment Safety Guidelines

- Make sure the machine is in a **Safe Condition** before performing any service work, maintenance procedures, or storage preparation. A Safe Condition for the machine involves the following:

 **SAFE CONDITION**

- Disengage the drive.
- Shut off engine.
- Make sure all moving parts have stopped.
- Remove spark plug cable.
- Turn fuel valve off.
- Block or chock wheels.

- Never use equipment with safety shields removed. Keep all shields in place. If shield removal becomes necessary for repairs, reinstall the shield prior to use.

- Replace any safety sign or instruction sign that is not readable or is missing. Location of safety signs is indicated in this manual.
- Do not allow anyone other than a responsible, properly trained and physically able person to operate this machine. This equipment is dangerous to children and persons unfamiliar with its operation.
- Do not modify the equipment in any way. Unauthorized modification may result in serious injury or death and may impair the function and life of the equipment.
- Never exceed the limits of the machine. If its ability to do the job or to do it safely is in question—**STOP IMMEDIATELY!**
- Determine where chips are piled and ensure the location does not interfere with safe operation of the machine.
- Determine a safe work area location:
 - Area must be clear of stones, branches or hidden obstacles that might cause a tripping, hooking, or snagging hazard.
 - Ground should be firm and level.
- Be aware of overhead hazards such as branches, cables, or electrical wires.
- Operate only in daylight or good artificial light.
- Make sure machine is properly adjusted and in good operating condition.
- Store fuel well away from the material pile.
- Perform the **Pre-operation Checklist** procedure before starting work. See *page 24*.

2.5 Safety Training

- The best safety feature is an informed, careful operator—we ask you to be that kind of operator. It is the operator's responsibility to read, understand and follow ALL safety and operation instructions in the manual.



- Train all new personnel and review instructions frequently with existing workers. Only properly trained and physically able operators should use this equipment. **A person who has not read and understood all operation and safety instructions is not qualified to use the machine.** Untrained operators expose themselves and bystanders to possible serious injury or death. If elderly people are assisting with the work, their physical limitations need to be recognized and accommodated.
- Learn the controls and how to stop the machine quickly in an emergency.
- If this machine is loaned or rented, it is the machine owner's responsibility to make certain that every operator:
 - reads and understands the owner's manual
 - is instructed in safe and proper use of the equipment
 - understands and knows how to perform the Safe Condition procedure

2.6 Be Prepared

- Wear appropriate personal protective equipment. Tie back long hair, remove jewelry, and avoid loose fitting clothing. Prolonged exposure to loud noise can cause permanent hearing loss! Wear hearing protection on a full-time basis when using this machine.
- Keep bystanders at safe distance at least 20 ft (6 m) from work zone. Mark the zone with safety cones.

2.7 Operating Safety

Read and obey the safety signs on the machine. Clean or replace them if they are not legible.

There is no substitute for a cautious, safe-minded operator who recognizes potential hazards and follows reasonable safety practices. This machine must be used with all its safety equipment properly installed to minimize the chance of accidents.

- Close and secure rotor cover, guards, deflectors and shields before starting and operating.
- Read and understand operator's manual before starting. Review safety instructions annually.
- Use care when feeding material into the chipper-shredder. Do not put metal objects, bottles, cans, rocks, glass or other foreign material into wood chipper. If such items happen to get into the chipper, stop machine and turn engine off. Wait for all moving parts to stop before removing material. Inspect machine for damaged or loose parts before resuming work.
- Personal protective equipment is recommended during assembly, installation, operation, adjustment, maintaining, repairing, removal, or moving. Do not allow long hair, loose-fitting clothing, or jewelry to be around moving parts.
- Do not allow anyone within the work or danger zone during operation. Ejected wood chips can cause injuries. Keep children away.
- Never place any part of your body where it would be in danger if machine movement should occur during assembly, installation, operation, maintenance, repairing, unplugging, or moving.
- Before servicing or repairing the machine, place it in a **Safe Condition**. See *page 8*.

- Do not operate on hillsides or when working area is cluttered, wet, muddy or icy to prevent slipping and tripping. Operate only on level ground.
- Position machine so prevailing winds blow engine exhaust fumes away from operator's station.
- Never use engine-powered machinery indoors. Gas engine exhaust contains toxic carbon monoxide, which cannot be smelled or seen. Breathing carbon monoxide can be lethal.
- Stop engine when leaving the machine unattended.
- Never consume alcohol or drugs which can hinder alertness or coordination while operating this equipment. Consult your doctor about operating this machine while taking prescription medications.
- Never allow children or unauthorized people to operate or be around this machine.
- Do not reach into rotor or feed hopper openings when the engine is running. Install and secure access covers before starting engine.
- Keep the working area clean and free of debris to prevent tripping.
- Do not point discharge at people, animals or buildings. Rotor can expel wood chips fast enough to cause injury.

2.8 Transport Safety

- Comply with local laws governing safety and transporting of machinery on public roads.
- Turn the engine and fuel supply off before transporting the machine.
- Inspect tires for cuts or damage. Check tire pressure and adjust if required.
- Do not allow riders on this machine at any time. There is no safe place for any riders.
- Make sure the fuel tank cap is tight to prevent spills while transporting.
- Clean all debris off the chipper.
- Before transporting, perform a walk-around inspection to ensure everything is safe.

2.9 Refueling Safety

- Engine fuel is highly flammable. Handle with care.
- Fill fuel tank outdoors.
- Stop the engine before refueling. Allow engine to cool for five minutes. Clean up spilled fuel before restarting engine.
- Do not overfill the fuel tank.
- If fuel is spilled, wipe it away carefully and wait until the fuel has dried before starting the engine.

- Do not refuel the machine while smoking or when near open flame or sparks.



- After refueling, make sure that the fuel cap is secured to prevent spillage.
- Prevent fires by keeping machine clean of accumulated trash, grease, and debris.

2.10 Gas Engine Safety



Before starting the engine, review the safety, operating, and maintenance instructions in the engine manual.

W019

- **DO NOT** operate engine in an enclosed area. Exhaust gases contain odorless and deadly carbon monoxide that can cause death by asphyxiation.
- **DO NOT** place hands or feet near moving or rotating parts.
- **DO NOT** store, spill, or use gasoline near an open flame, or devices such as a stove, furnace, or water heater which use a pilot light or devices which can create a spark.
- **DO NOT** refuel indoors where area is not well ventilated.
- **DO NOT** choke carburetor to stop engine. Whenever possible, gradually reduce engine speed before stopping.
- **DO NOT** run engine above rated speeds. This may result in injury.
- **DO NOT** tamper with governor springs, governor links or other parts which may increase the governed speed.
- **DO NOT** tamper with the engine as set by the original equipment manufacturer.
- **DO NOT** check for spark with spark plug or spark plug wire removed.
- **DO NOT** crank engine with spark plug removed. If engine is flooded, crank until engine starts.
- **DO NOT** operate engine with an accumulation of grass, leaves, dirt or other combustible materials in the muffler area.
- **DO NOT** use this engine on any forest covered, brush covered, or grass covered unimproved land unless a spark arrester is installed on the muffler. The arrester must be maintained in effective working order by the operator. In the state of California, the above is required by law (Section 4442 of the California Public Resources Code). Other states may have similar laws. Federal laws apply on federal land.

- **DO NOT** touch hot muffler, engine body or cooling fins. Contact may cause burns.
- **DO NOT** run engine with air cleaner or air cleaner cover removed.

Be sure to:

- Remove the wire from the spark plug when servicing the engine or equipment to prevent accidental starting. Disconnect the (-) ground wire from the battery terminal.
- Keep engine cooling fins and governor parts free of grass and other debris that can affect engine speed.
- Examine muffler periodically to be sure it is functioning effectively. A worn or leaking muffler should be repaired or replaced as necessary.
- Use fresh gasoline. Old fuel can clog carburetor and cause leakage.
- Check fuel lines and fittings frequently for cracks or leaks. Replace if necessary.

2.11 Maintenance Safety

- Follow good shop practices:
 - Keep service area clean and dry.
 - Be sure electrical outlets and tools are properly grounded.
 - Use adequate light for the job at hand.



- Never operate the machine in a closed building. The exhaust fumes may cause asphyxiation.
- Before servicing or repairing, place the machine in a **Safe Condition**. See *page 8*.
- Allow the engine to cool before performing maintenance. Engine components and oil may be hot enough to cause injury.
- Never work under equipment unless it is properly supported.
- When performing any service or maintenance work always use personal protective equipment.
- Have a fire extinguisher and first aid kit readily accessible while performing maintenance on this equipment.
- Where replacement parts are necessary, use only OEM parts to restore your equipment to original specifications. The manufacturer is not responsible for injuries or damages caused by use of unapproved parts or accessories.
- Inspect and tighten all bolts, nuts and screws. Check that all electrical and fuel connections are properly secured.
- When completing a maintenance or service function, make sure all safety shields and devices are installed before placing chipper in service.
- When cleaning any parts, do not use gasoline. Use a cleanser designed for that purpose.
- Always use proper tools in good condition. Make sure you understand how to use them, before performing any service work.

3. Safety Signs

3.1 Safety Sign Locations

The top (or left-hand) panel shows the safety alert (the potential hazard), and the bottom (or right-hand) panel shows the message (how to avoid the hazard).

Practicing good safety means becoming familiar with safety signs and warnings and being aware of the situations that require alertness.

Think SAFETY! Work SAFELY!

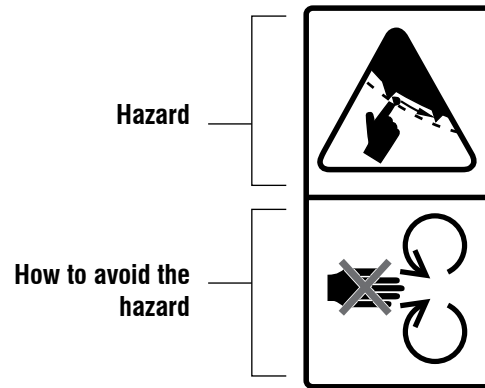

Safety

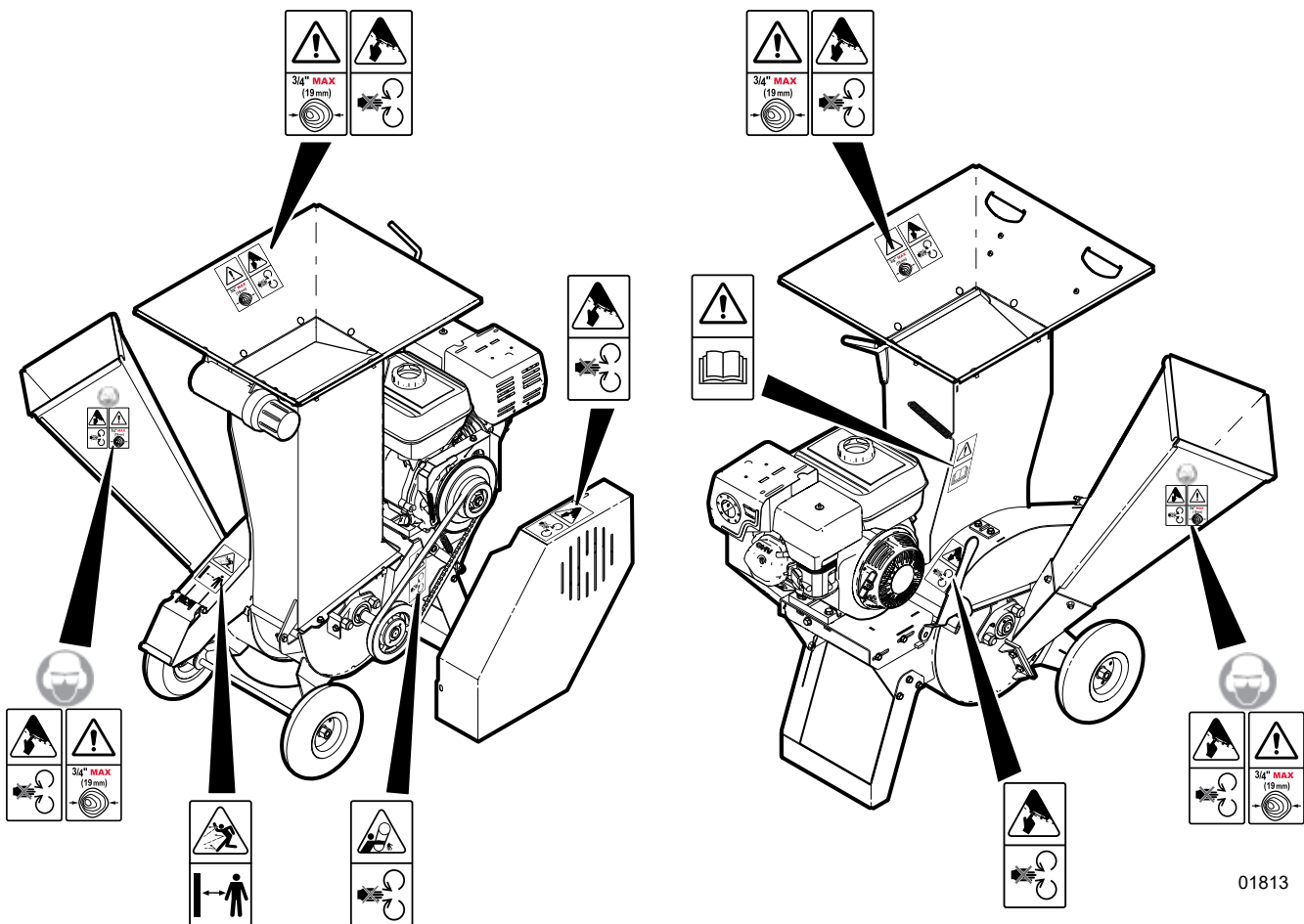

01813

Fig. 2—BXMC Safety Decals (Typical for all models)

3.2 Safety Sign Explanations

IMPORTANT! If safety signs have been damaged, removed, become illegible or parts replaced without safety signs, new signs must be applied.

New safety signs are available from your authorized dealer.

1. CAUTION!!

Risk of personal injury or equipment damage.

Do not put material larger than 3.0" (75 mm) diameter into the chipper. Attempting to chip anything larger could stall the engine, damage the machine or cause personal injury.



2. CAUTION!

Risk of injury from flying objects.

Stay clear of material discharge chute. Machine can expel wood chips fast enough to cause injury. Do not point discharge at people, animals, or buildings.



3. WARNING!

Risk of serious injury.

Keep hands and feet out of inlet and discharge openings while machine is operating.

Wait for all moving parts to come to a complete stop before clearing obstructions.

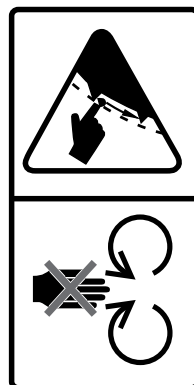

4. CAUTION!

Refer to the operator's manual for important safety information.

Understand ALL operating instructions in the manual and understand ALL safety signs located on the machine. The most important safety device on this equipment is an informed operator.

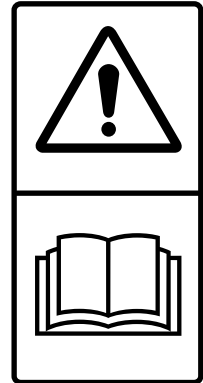

5. WARNING!

Risk of serious injury or death if hands or limbs are caught in rotating parts.

Do not operate machine without shields in place. If shield is removed, replace it before operating machine.

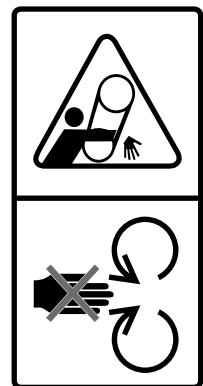

6. CAUTION!

Risk of personal injury or equipment damage.

Do not put material larger than 3/4" (19 mm) diameter into the Shredder. Attempting to shred anything larger could stall the engine, damage the machine or cause personal injury.



7. CAUTION!

Personal Protective Equipment (PPE) is required when operating this machine.

Failure to wear PPE can result in personal injury



IMPORTANT! If parts are replaced that have safety signs on them, new signs must be applied. Safety signs must always be replaced if they become damaged, are removed, or become illegible.

Safety signs are included in the product decal kit available from your authorized dealer. Decals are not available separately.

3.3 Replace Damaged Safety Signs

- Always replace safety signs that are missing or have become illegible. Replacement safety signs are available from your authorized distributor, dealer parts department, or the factory.
- Always keep safety signs clean and legible.
- Parts replaced that had a safety decal on them must also have the safety sign replaced.

Procedure

Installation area must be clean and dry. Make sure the surface is free of grease or oil. Ambient temperature must be above 50 °F (10 °C).



Determine exact position before removing the backing paper on the decal.

1. Peel the decal off the backing sheet.
2. Align the decal with an edge on the machine if possible.
3. Starting on one edge, carefully press the center of the exposed sticky backing in place, smoothing it out as you work from one side to the other.
4. Use a squeegee, credit card or similar to smooth it out. Work from one end of the decal to the other end.

Small air pockets can be pierced with a pin and smoothed out using the piece of sign backing paper.

4. Familiarization

Wallenstein wood chipper-shredders are designed to chip and chop small trees, brush, limbs and other wood debris. The chipped material is fine enough to be composted or used in a variety of ways.

IMPORTANT! Do not put metal objects, bottles, cans, rocks, glass or other foreign material into wood chipper. If such items happen to get into the chipper, stop machine and turn engine off. Wait for all moving parts to stop before removing material. Inspect machine for damaged or loose parts before resuming work.

4.1 To the New Operator

It is the responsibility of the owner or operator to read this manual and to train all other operators before they start working with the machine. Follow all safety instructions exactly.

By following recommended procedures, a safe working environment is provided for the operator, bystanders and the area around the work site. Untrained operators are not qualified to use the machine.

Many features incorporated into this machine are the result of suggestions made by customers like you. Read this manual carefully to learn how to use the machine safely and provide maximum operating efficiency. By following the instructions in conjunction with a good maintenance program, your wood chipper can provide many years of trouble-free service.

IMPORTANT! Make sure all operators understand how to put the machine in a Safe Condition before working with this machine. See Safe Condition *page 8*.

4.1.1 Operator Orientation

IMPORTANT! When describing controls, the directions for left-hand, right-hand, backward and forward as mentioned throughout this manual, are determined when standing at the feed hopper with hands placed in the handholds.

4.1.2 Training

Each operator must be trained in the proper set-up and operating procedures before operating the machine.

1. Move the unit to a large open area to allow the operator to become familiar with control functions and machine response.
2. Do not allow untrained operators to use the machine. They can endanger themselves and others, or damage property and the machine.

4.1.3 Job Site Familiarization

It is the responsibility of the operator to be thoroughly familiar with the work site prior to starting.

1. Check for close or cramped work space. Be sure there is sufficient space and clearance for the machine to operate.
2. Organize the working area to minimize movement.
3. Position the machine so prevailing winds blow engine exhaust fumes away from operator.

4.2 Machine Components

The Wallenstein Chipper-Shredder rotor has blades and knives for chipping and shredding wood and brush. Feed hoppers supply the material into the rotor for chipping and into the knives for shredding.

The chipper rotor is designed with two blades to provide uniform chip size. The shredder rotor is equipped with three sets of swinging knives to provide a fine mulch. A chop-block in the shredder compartment shreds the material as it moves through the machine.

A gas engine provides power to the rotor through a V-belt drive system. A braking clutch on the engine stops the rotor when the drive is disengaged.

BXMC34B

BXMC3409B

1. Shredder Feed Hopper
2. Shredder Hopper Flap Handle
3. Shredder Hopper Flap
4. Handholds
5. Chipper Feed Hopper
6. Twig Breaker
7. Ledger knife
8. Operator's Manual Tube
9. Discharge Chute
10. Tires – 4.10-3.50 Rubber
11. Clutch Actuator Lever
12. BXMC34B – Honda® GX200;
BXMC3409B – Honda® GX270
13. Front Leg Support
14. Jockey Wheel
15. Mulch Collector Bag (not shown)

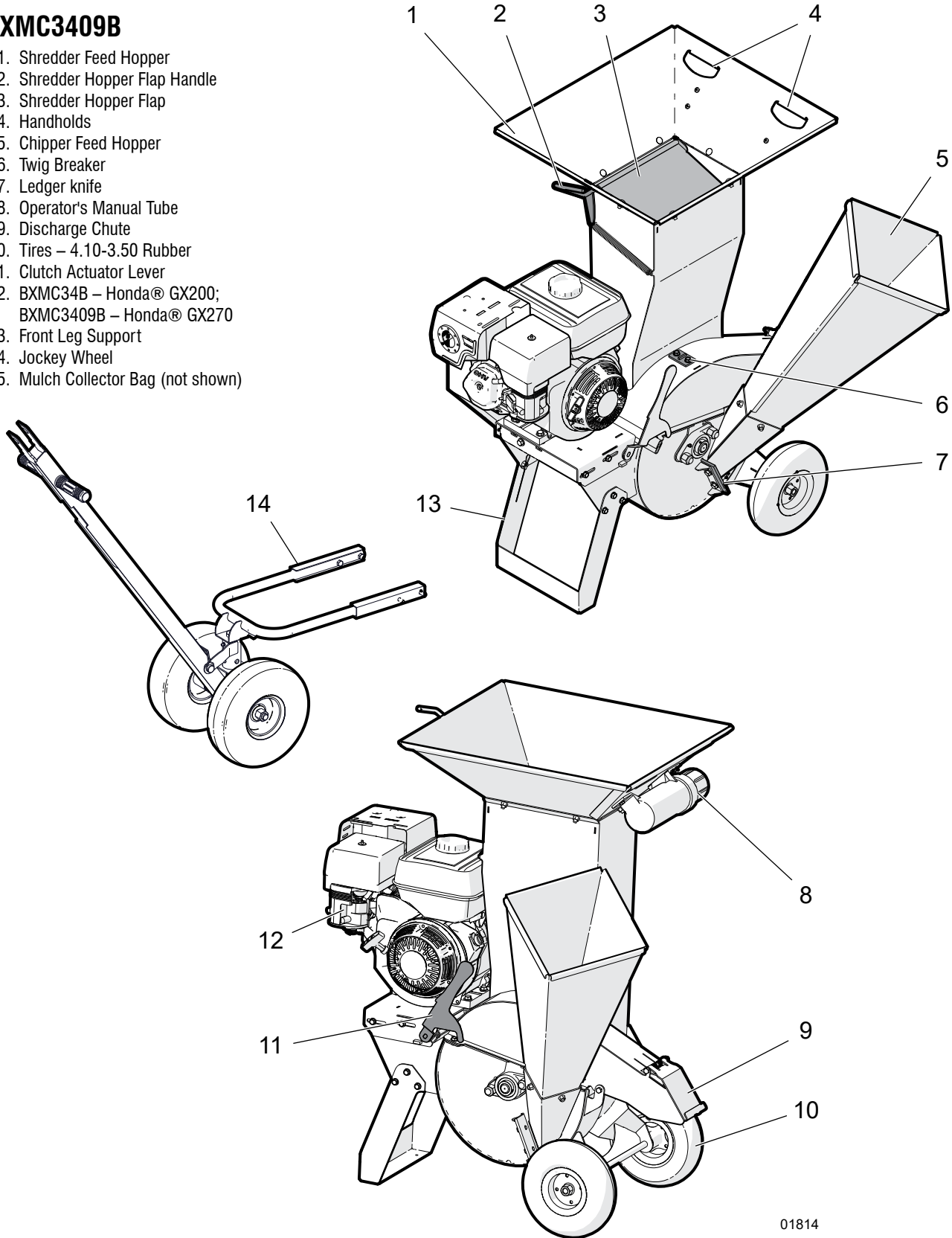

01814

Fig. 3–BXMC34B, BXMC3409B Components

BXMC34B

BXMC3409B

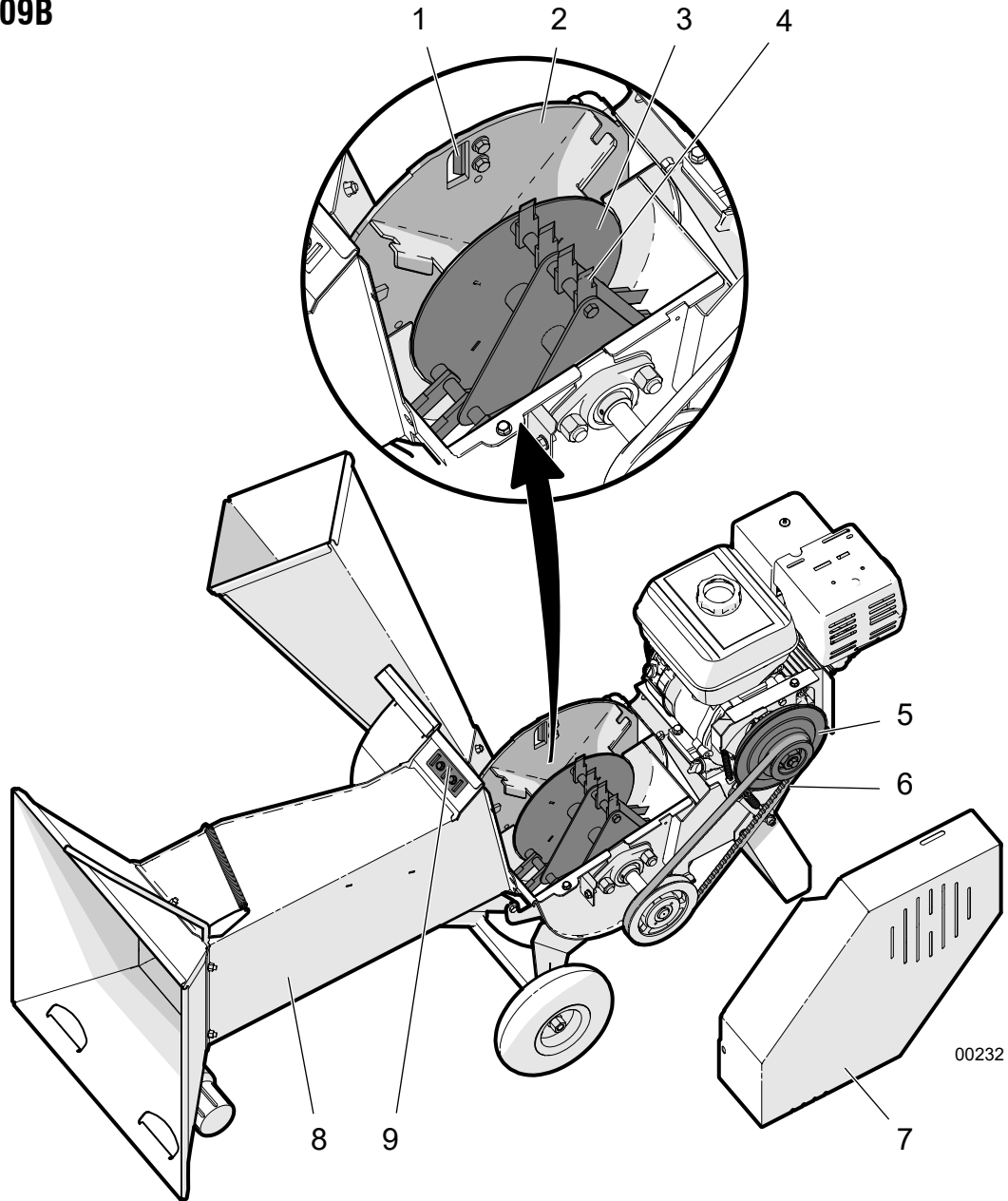

Fig. 4 – BXMC34B, BXMC3409B Components

- 1. Rotor Knife
- 2. Rotor
- 3. Chipper Rotor Plate
- 4. Shredder Knives
- 5. Brake Clutch
- 6. Drivebelt
- 7. Drivebelt Guard
- 8. Upper Rotor Housing
- 9. Chop Block

BXMC34S

BXMC3409S

1. Shredder Hopper Flap Handle
2. Shredder Feed Hopper
3. Shredder Hopper Flap
4. Handholds
5. Chipper Feed Hopper
6. Ledger knife
7. Operator's Manual Tube
8. Tires – 4.10-3.50 Rubber
9. Clutch Actuator Lever
10. BXMC34B – Honda® GX200;
BXMC3409B – Honda® GX270
11. Shredder Guard

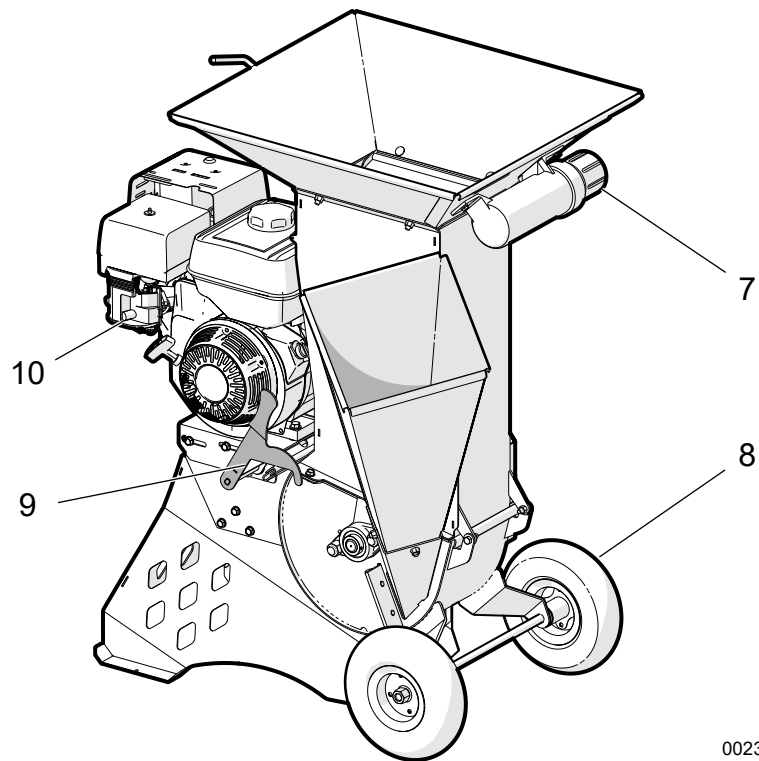
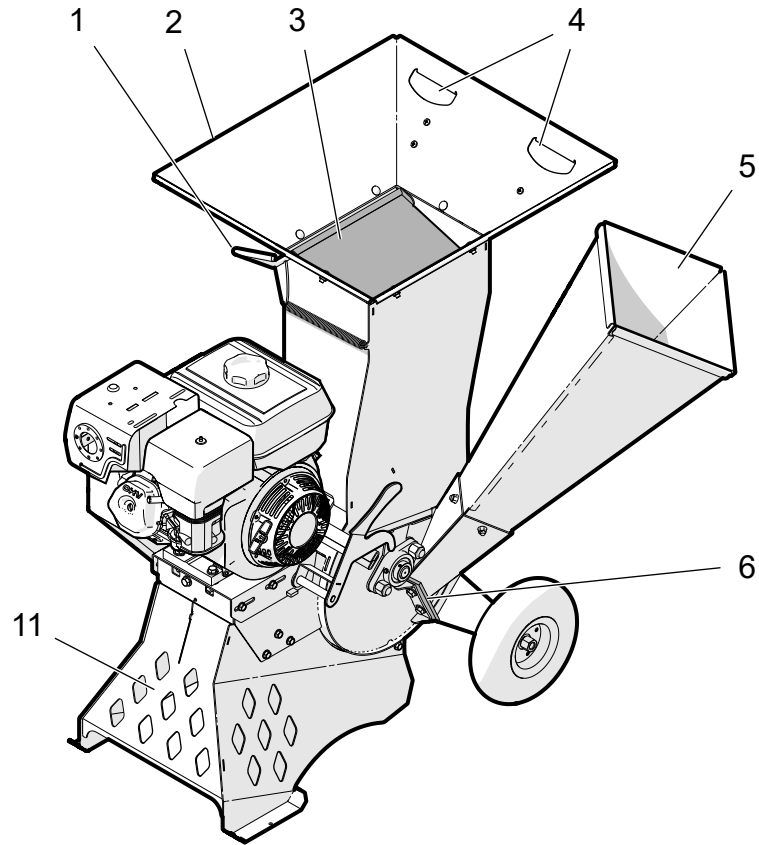

00233

Fig. 5 – BXMC34S, BXMC3409S Components

BXMC34S

BXMC3409S

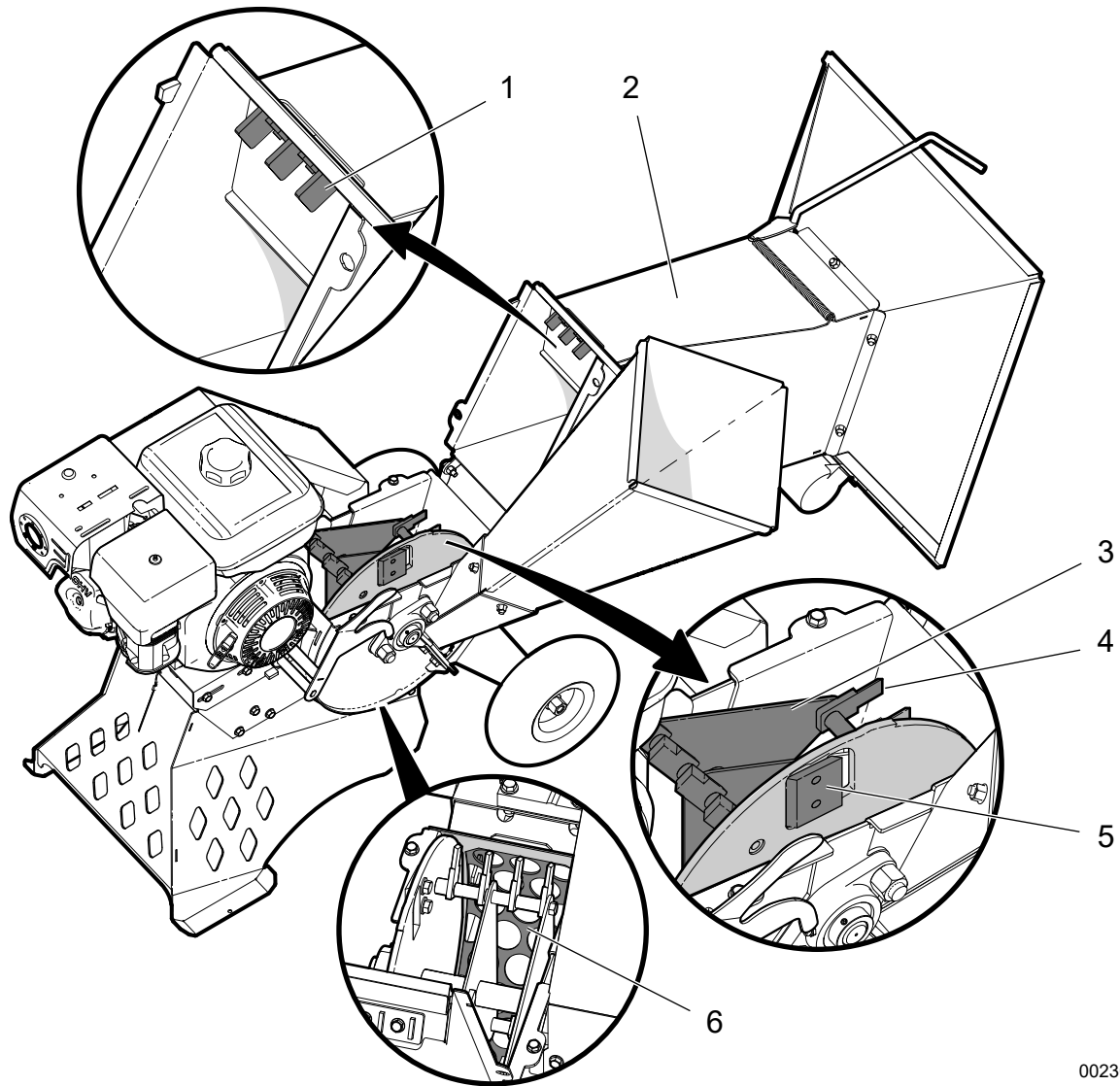

00230

Fig. 6–BXMC34S, BXMC3409S Components

- 1. Chop Block
- 2. Upper Rotor Housing
- 3. Chipper Rotor Plate
- 4. Shredder Knives
- 5. Rotor Knife
- 6. Screen

5. Controls

IMPORTANT! Before starting to work with the chipper, become familiar with the location and function of all controls.

5.1 Engine Controls

Refer to the engine manual for further explanation on engine controls.

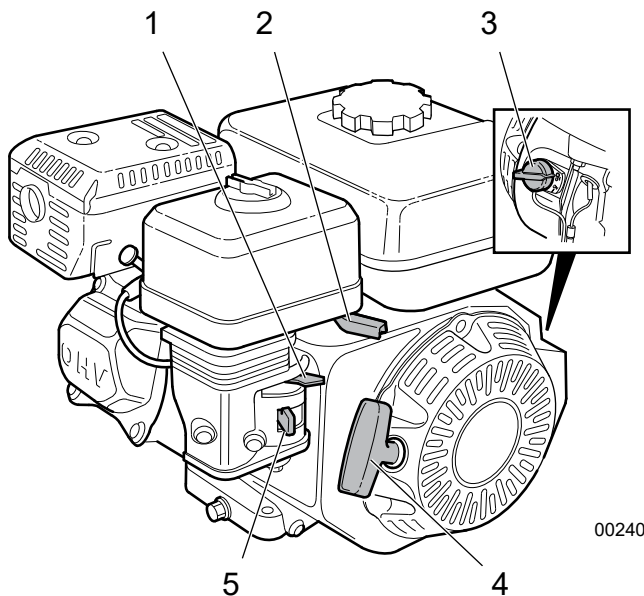

Fig. 7—Engine Controls

1. Choke Lever
2. Throttle Lever
3. Ignition Switch
4. Starting Rope
5. Fuel Valve Lever

5.1.1 Ignition Switch

This rotary switch controls the ignition system.

- The engine operates in the ON position. Turn the switch to **ON** before starting the engine,
- To stop the engine, turn the switch counterclockwise to **OFF**.

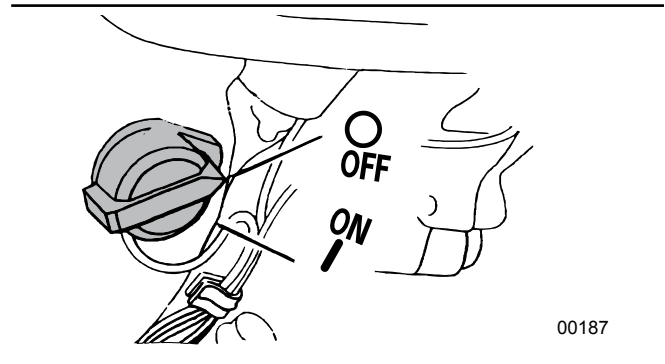

Fig. 8—Ignition Switch Positions

5.1.2 Choke Lever

The choke lever opens and closes the choke valve in the carburetor.

- Move the choke lever to **CLOSED** when starting a cold engine.
- Move the choke lever to **OPEN** after the engine starts.
- When restarting a warm engine, leave the lever in the **OPEN** position.

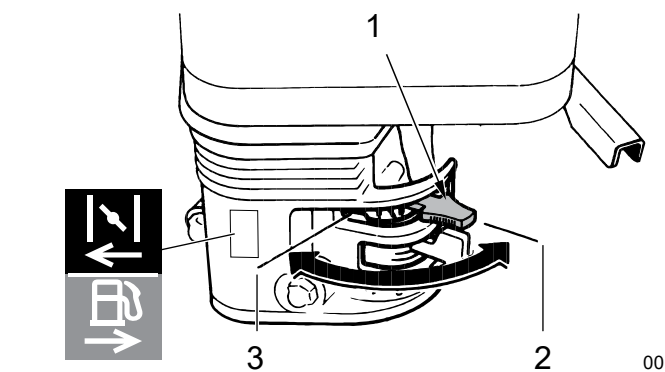

Fig. 9—Carburetor Choke Lever

1. Choke Lever
2. Choke OPEN
3. Choke CLOSED

5.1.3 Fuel Shut-off Valve

The engine is equipped with a fuel shut-off valve between the fuel tank and the carburetor.

- Slide the fuel valve lever to **ON** to open the fuel valve. Turn it to **OFF** to turn the fuel valve off.
- Turn the fuel valve off when not in use or when transporting.

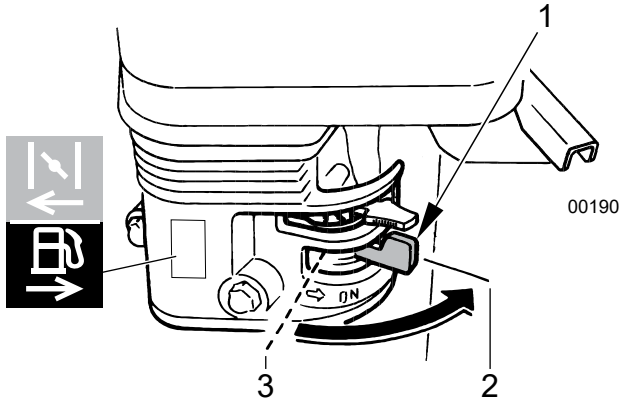

Fig. 10–Fuel Shut Off Valve

1. Fuel Shut-off Valve Lever
2. Fuel ON
3. Fuel OFF

5.1.4 Throttle Lever

This lever controls the engine speed. Move the lever from side to side to increase or decrease engine rpm. **Always operate the chipper with the throttle lever in the MAX position.**

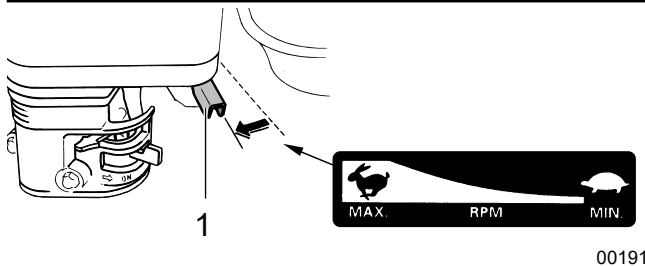

Fig. 11–Engine Throttle Control

1. Throttle Lever

5.1.5 Recoil Starter

To start the engine, pull the starter grip out lightly until resistance is felt, then pull briskly in the direction of the arrow as shown below. Return the starter grip gently.

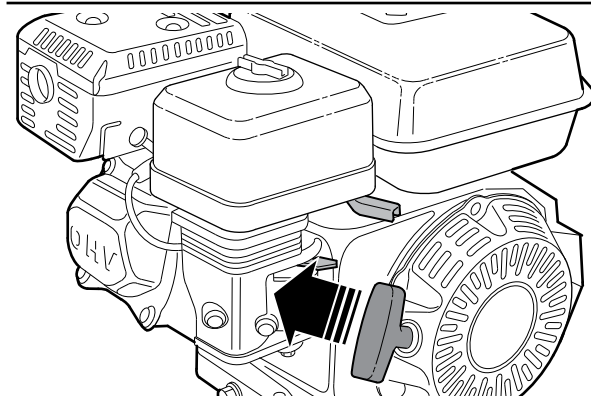

Fig. 12–Recoil Starter

5.2 Shredder Hopper Flap

The shredder hopper has a spring-loaded flap to control the material flow into the shredder rotor. The flap also prevents material from flying back out while it is being shredded.

Use the hopper flap handle to control the flap position and how much and how fast the material is delivered into the shredder.

- Push the flap handle down to open the flap and allow the material to drop into the shredding rotor.
- Release the flapper handle and the spring returns the flap into its closed position.

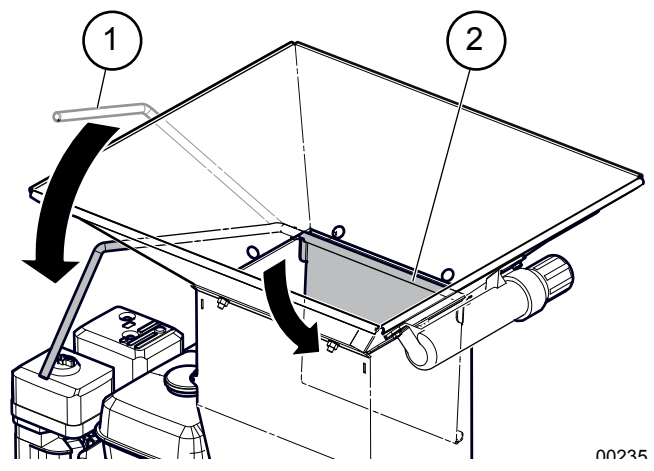

Fig. 13–Shredder Hopper Flap

1. Hopper Flap Handle
2. Shredder Hopper Flap

5.2.1 Shredder Hopper Handholds

The shredder hopper has handhold openings used to move the chipper.

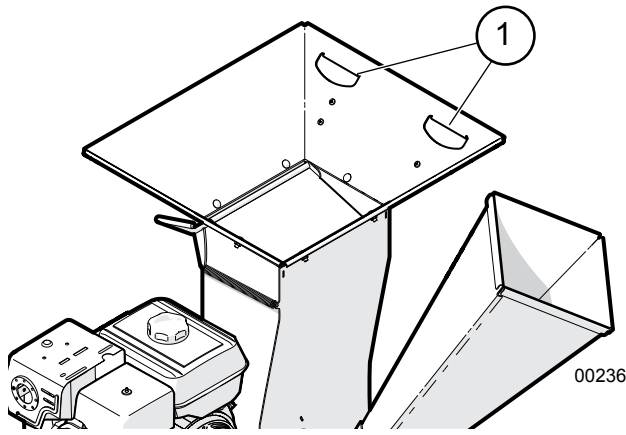
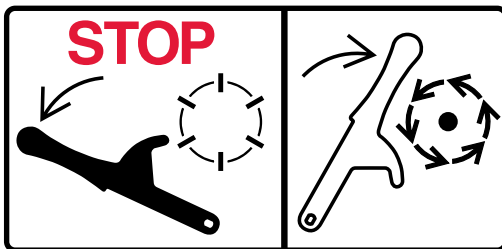

Fig. 14—Shredder Hopper Handholds

- 1. Handholds

5.3 Clutch Actuator Lever

The clutch lever engages / disengages the drive system.



5.3.1 Drive Position

- Push the lever fully toward the rotor housing to engage the chipper-shredder drive system.

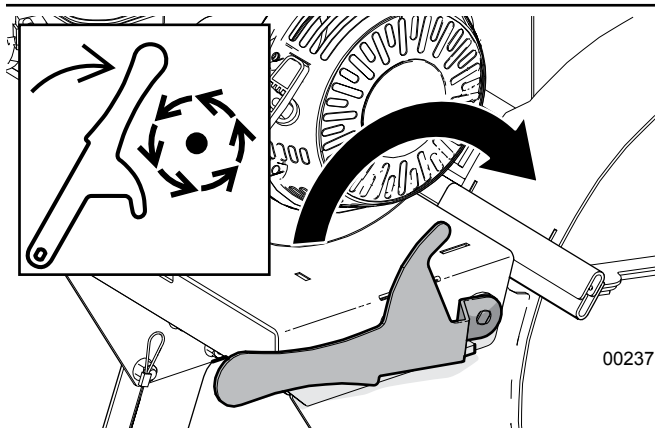

Fig. 15—Engaging Drive System

NOTE: *With the drive engaged, opening the upper rotor housing is prevented.*

5.3.2 Stop Position

- Moving the lever fully away from the rotor housing disengages the drive system, applies the brake clutch, and stops the rotor.

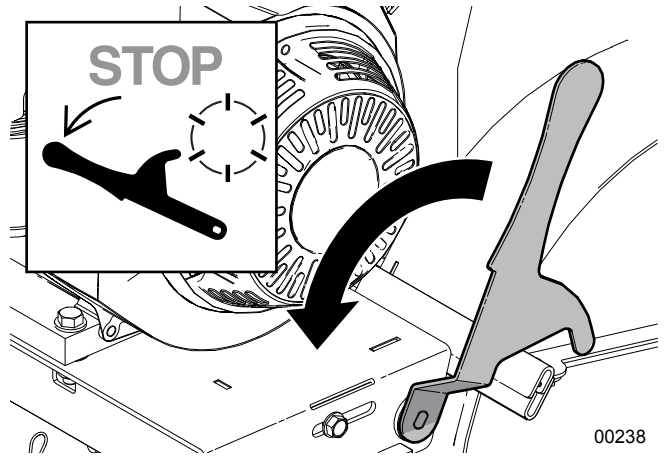

Fig. 16—Disengaging Drive System

6. Operation

CAUTION!



Hearing loss hazard. Prolonged exposure to loud noise may cause permanent hearing loss. Use suitable protection while operating the machine.

W016

The operator has the responsibility of being familiar with and following all operating and safety procedures.

Although this machine is easy to use, each operator should review this section to get familiar with the detailed safety and operating procedures.

Before beginning work, it may be helpful to sort the material into separate piles for chipping and shredding.

- The chipper (1) has a **3" (76 mm)** diameter maximum capacity.
- The shredder (2) has a **3/4" (19 mm)** diameter maximum capacity.

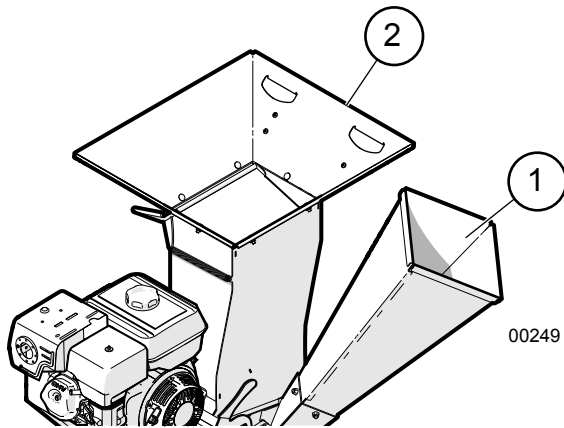

Fig. 17–Chipper and Shredder Hoppers

1. Chipper Hopper
2. Shredder Hopper

Always wear appropriate PPE whenever operating the machine.

Do not place metal, bottles, cans, rocks, glass or other solid material into the wood chipper. If something like this gets into the machine, stop immediately to remove it and perform a detailed inspection.

If opening any guards for inspection, always put the machine in a **Safe Condition** as follows:

SAFE CONDITION

- Disengage the drive.
- Shut off engine.
- Make sure all moving parts have stopped.
- Remove spark plug cable.
- Turn fuel valve off.
- Block or chock wheels.

Inspect machine for damaged or loosened parts, repair or replace parts as required before resuming work.

6.1 Before Starting the Engine

1. Check the engine oil level. See *page 26*.
2. Check the fuel level. See *page 25*.
3. Check the engine air cleaner. See engine manual.
4. Review the Safety Rules on *page 9*.
5. Clear the area of bystanders, especially small children.
6. Make sure each operator is trained and familiar with the set up and operation of the wood chipper.
7. Perform the Pre-operation Checklist. See next page.
8. Survey the work site and place the chipper in a clear, level work area.

6.2 Pre-operation Checklist

Check the following each time the chipper-shredder is used:

Pre-operation Checklist	✓
Check the rotor main shaft bearings have been lubricated. See <i>page 34</i> .	
Check the tension and alignment of the drive belt. Adjust as required. See <i>page 35</i> .	
Check the rotor housing and discharge chute. Remove any blockages, twine, wire or other material that has become entangled.	
Check the condition and clearance of the twig breaker, rotor and stationary blades. Adjust or replace as required. See <i>page 38</i> .	
Check and ensure that all covers, guards and shields are in place, secured, and can function as designed.	
Check and tighten all fasteners. Make sure the equipment is in good condition.	
Check that appropriate equipment for personal protection is available and being used.	
Check that jewelry, loose-fitting clothing are not worn. Make sure long hair is tied back.	

6.3 Machine Break-in Period

Although there are no operational restrictions on the Wallenstein Chipper-Shredder when used for the first time, it is recommended that the following items be checked:

A. After operating for 1 hour:

1. Torque all fasteners and hardware.
2. Check condition of rotor bearings.
3. Check the condition and clearance of the knives, chop-block and stationary blades. Adjust or replace as required.
4. Check drive belt tension and pulley alignment.
5. Check the condition of the hopper flap in the shredder feed hopper. The hopper flap must move freely back into position to ensure the safety of the operator by preventing wood from flying out.
6. Check for entangled material. Remove all entangled material before resuming work.
7. Check engine fluid levels. Top up as required.

B. After operating for 10 hours:

8. Repeat all previous steps.
9. Perform all the checks in the Pre-operation Checklist. See *page 24*.

C. After operating for 20 hours:

10. Change engine oil. Refer to engine manufacturer's manual included in the manual tube.

6.4 Fuel Level Check

Check the fuel level every time the chipper is used.

Starting with a full tank helps to eliminate or reduce operating interruptions for refueling.

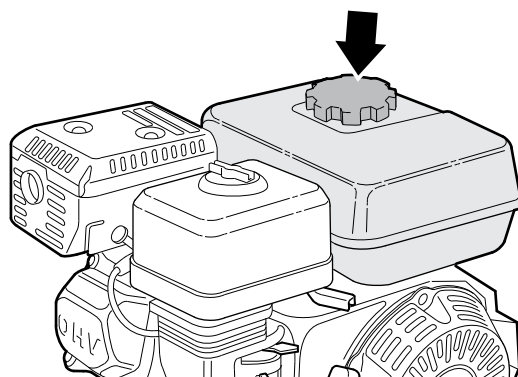

Fig. 18—Fuel Level Check

6.4.1 Refueling

Refer to engine manufacturer's manual for fuel tank capacity.

⚠ WARNING!



Fuel vapors can explode causing injury or death. Do not smoke while refueling. Keep sparks, flames, and hot components away.

W027

Refuel in a well-ventilated area with the engine stopped. If the engine has been running, allow it to cool first. Never refuel the engine inside a building where gasoline fumes can encounter flames or sparks.

Do not fill the fuel tank completely. Fill tank to approximately 1 inch (25 mm) below the top of the fuel tank to allow for fuel expansion. It may be necessary to lower the fuel level depending on operating conditions. After refueling, tighten the fuel tank cap securely.

For fuel specification, see *Engine Fuel* on page 33. Refer to the engine manual for additional information on fuels.

6.5 Engine Oil Level Check

Check engine oil level daily.

Check with the machine parked on level ground and the engine stopped.

IMPORTANT! Running the engine with a low oil level can cause engine damage that is not covered by warranty.

1. Remove the filler cap/dipstick and wipe it clean.
2. Insert and remove the dipstick **without** screwing it into the filler neck.
3. Check the oil level shown on the dipstick.
4. If the oil level is low, fill to the edge of the oil filler hole.
SAE 10W-30 is recommended for general use.
5. Screw in the filler cap/dipstick securely.

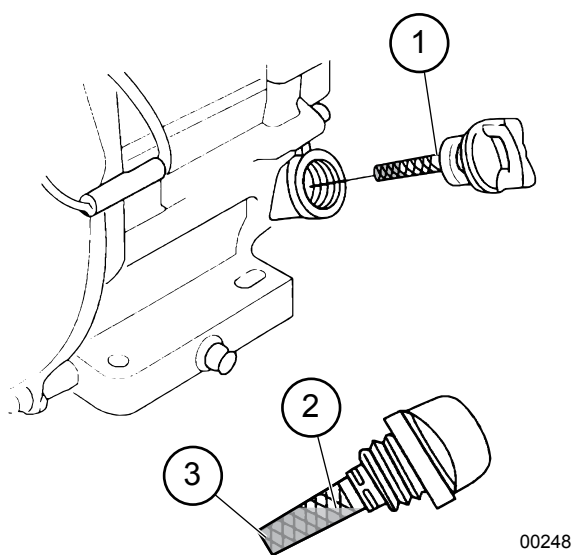

Fig. 19—Engine Oil Level Check

1. Filler Cap/Dipstick
2. Upper Oil Level Limit
3. Low Oil Level Limit

6.6 Machine Set-up



Do not use chipper/shredder on uneven ground. Machine may tip over resulting in personal injury or damage to the machine. Chipper/shredder must be resting on the level and stable ground during operation.

W038

1. Position the chipper / shredder at the work site close to the brush pile.

IMPORTANT! Position the machine so the prevailing wind blows engine exhaust away from the operator.

2. Ensure that the machine is resting on the ground and is level and stable, and the work area is free of debris.
3. If the machine is attached to a lawn tractor, apply the brakes and chock the wheels.
4. Ensure the feed hoppers are free of debris (to prevent jamming at start up).

BXMC34B / BXMC3409B

5. Position the discharge chute as required, pointing away from people or animals.

BXMC34S / BXMC3409S

6. Check that the appropriate shredder screen is installed. Position the machine.

6.7 Starting the Engine

NOTE: For additional engine information, refer to the engine manufacturer owner's manual in the manual tube.

1. If the engine is cold, pull out (close) the choke. To start a warm engine, leave the choke pushed in.
2. Move the throttle lever up to 1/4 throttle position.
3. If the engine is cold, close the choke (push choke lever to the left). To start a warm engine, leave the choke open (choke lever pushed to the right).

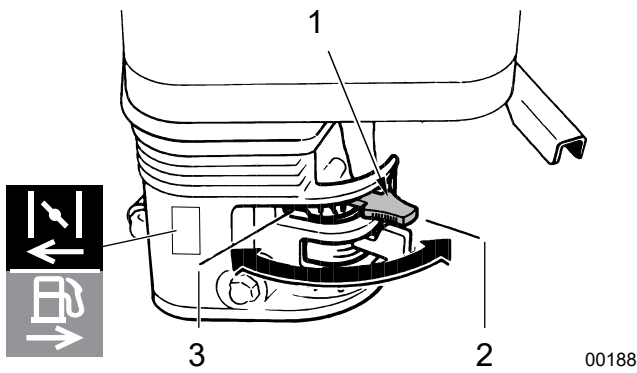

Fig. 20–Choke Lever

1. Choke Lever
2. Choke Open Position
3. Choke Closed Position

4. Move the throttle lever away from the **MIN.** position, about 1/3 of the way toward the **MAX** position.

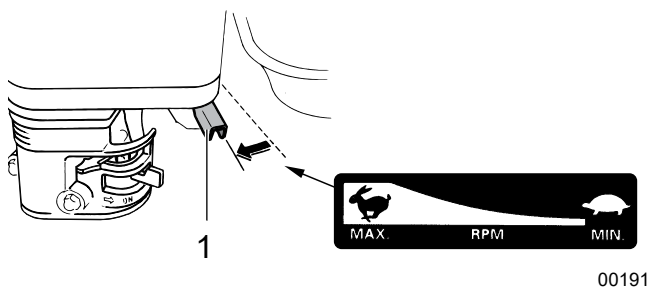

Fig. 21–Engine Throttle

1. Throttle Lever

5. Turn the engine ignition switch to the **ON** position.

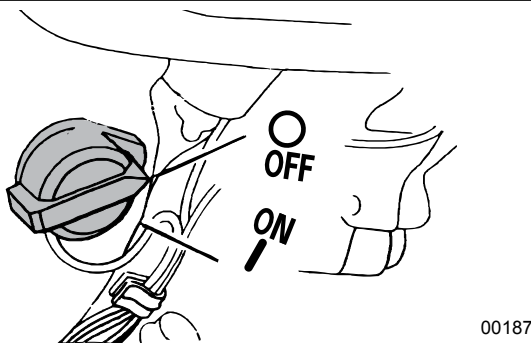

Fig. 22–Ignition Switch

6. Pull the starter grip out lightly until resistance is felt, then pull briskly in the direction of the arrow as shown below. Return the starter grip gently.

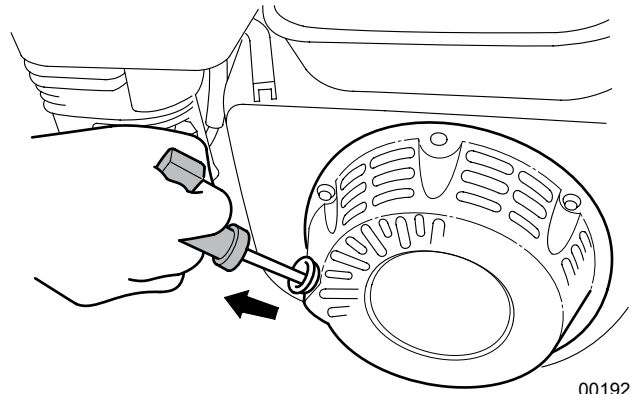

Fig. 23–Recoil Starter

IMPORTANT! Do not allow the starter grip to snap back against the engine. Return it gently to prevent damage to the starter.

- Leave the engine operating at low throttle for a few minutes to allow it to warm up.
- Gradually push the choke control lever open (to the left) as the engine warms.

IMPORTANT! Engine should be warmed up before putting to work.

- Once the engine is warmed, increase the throttle setting to **MAX**.

6.8 Stopping Procedure

1. Stop feeding material into the hopper. Allow the machine to run for a few minutes so the chipper clears itself.
2. Decrease engine speed to **MIN**.
3. Disengage the drive system.
4. Turn the ignition switch **OFF**.

6.9 Stopping in an Emergency

In an emergency:

- Turn the ignition switch **OFF**.
- Correct fault situation before restarting engine and resuming work.

6.10 Engaging Drive

The clutch lever engages / disengages the drive system.

IMPORTANT! Make sure rotor housing and hoppers are clear before engaging clutch. Engage slowly. Engaging the drive too quickly may cause the engine to stall.

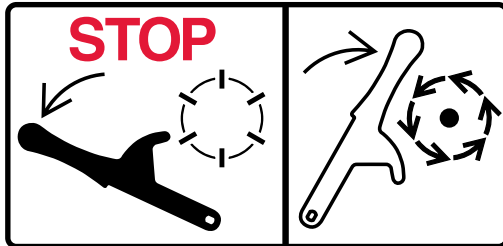

- Push the lever fully toward the rotor housing to engage the chipper-shredder drive system.

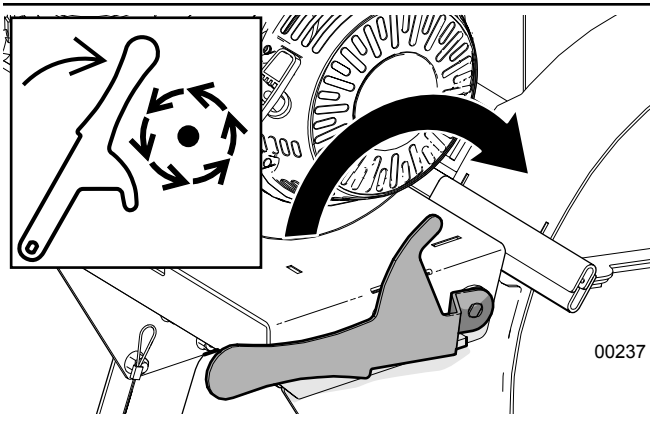

Fig. 24—Engaging Drive System

NOTE: When the rotor drive is engaged, the upper rotor housing cannot be opened.
When the rotor drive is disengaged, the clutch brake engages and stops the rotor.

6.11 Chipping Operation

! WARNING!



Never reach into the feed hopper when the chipper is operating. Doing so risks contacting knives on the rotor and causing serious injury.

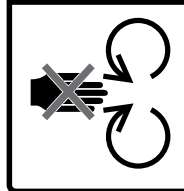

Use a stick or branch to push any material in that does not move on its own. If the jam persists, stop the engine and clear the jam.

W039

- When the rotor is up to speed, carefully slide the material into the chipper feed hopper and into the rotor. The rotor will tend to draw the material through.

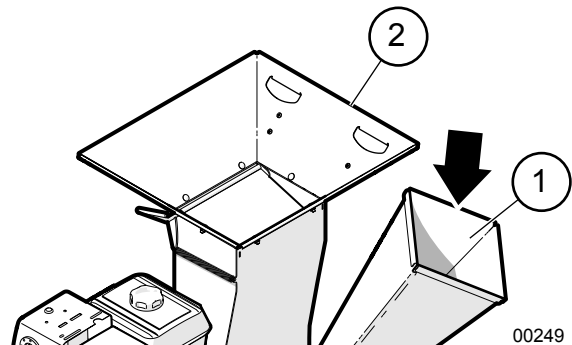

Fig. 25—Chipper Operation

1. Chipper Feed Hopper
2. Shredder Feed Hopper

- Feed the material into the hopper at a slow, steady rate.
- If the rotor begins to slow down, stop feeding material. Let the rotor get back up to speed, then continue.
- Do not reach into the chipper feed hopper further than the hopper opening.
- Use a stick or branch to push any material in that does not move on its own.

NOTE: Brush or limbs less than 3/4" (19 mm) in diameter can be fed through the shredder.

6.12 Shredding Operation

WARNING!

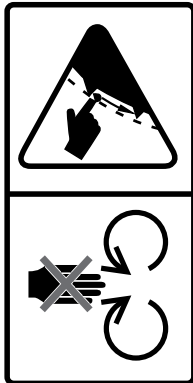

Never reach into the feed hopper when the chipper is operating. Doing so risks contacting knives on the rotor and causing serious injury.

Use a stick or branch to push any material in that does not move on its own. If the jam persists, stop the engine and clear the jam.

W039

- When the rotor is up to speed, fill up the shredder feed hopper with material to be shredded.

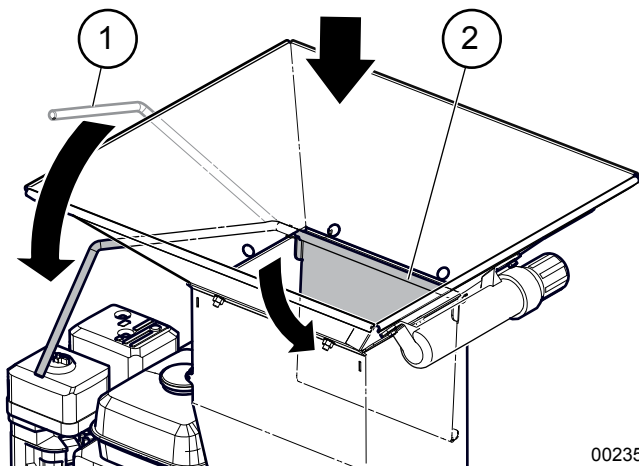

00235

Fig. 26–Shredder Hopper

1. Hopper Flap Handle
2. Shredder Hopper Flap

- Use the hopper flap handle to open the flap. Control how much and how fast the material is delivered into the shredder by varying the flap opening.
- If the shredder begins to slow down, close the hopper flap and let the shredder get back up to speed. Open the hopper flap back up to continue.
- Do not reach into the shredder feed hopper further than the flap.
- Use a stick or branch to push any material in that does not move on its own.
- Release the handle and the flap will close. Ensure the flap is closed between feeds to keep flying material contained in the shredder housing. **Do not prop the flap open.**

6.13 Moving the Chipper

IMPORTANT! The engine manufacturer recommends turning the engine off before tilting the chipper. Tilting it can cause a low oil level situation.

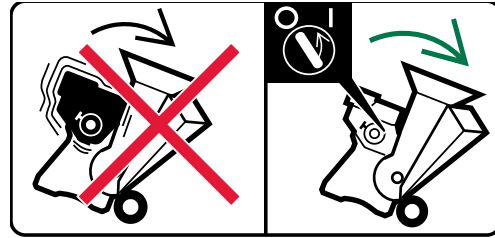

The chipper-shredder is designed to be moved easily by leaning it back on its wheels using the handholds in the shredder intake chute.

- Shut the engine down and disengaged the clutch before moving.
- Lean the chipper back onto its wheels and reposition.

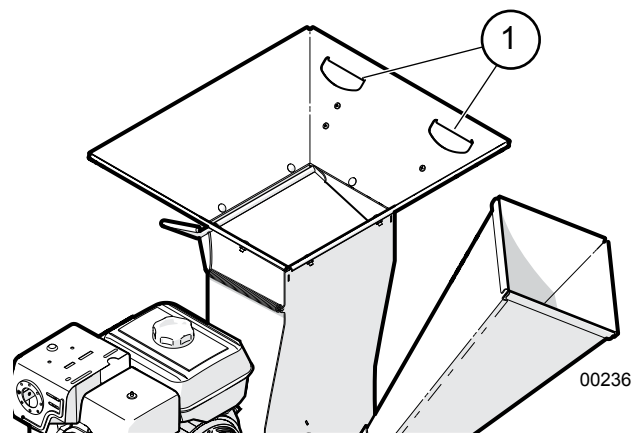

00236

Fig. 27–Shredder Hopper Handholds

1. Handholds

- On the BXMC34S and BXMC3409S models, the wood mulch is directed into the discharge cage under the motor. The machine must be moved periodically to prevent plugging as mulch builds up.

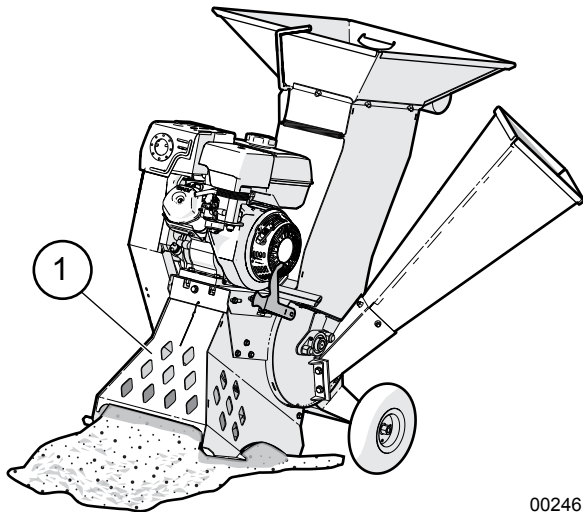

00246

Fig. 28—BXMC34S and BXMC3409S

1. Discharge Cage

6.14 Mulch Collector Bag

The BXMC34B and BXMC3409B models include a Mulch Collector Bag. Attach it to the discharge chute. The collector bag holds 2.7 ft³ (28 L) of material. The porous fabric allows air from the rotor to pass through without restricting collection of the mulch.

- To install the collector bag, lift the spring-loaded deflector and slip the bag over the end of the discharge chute.

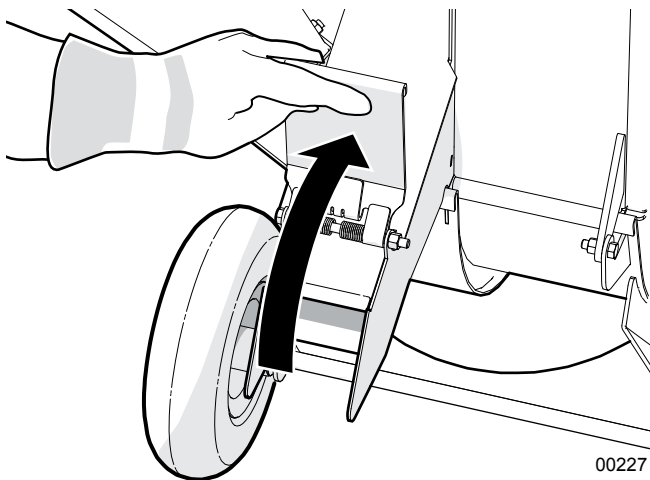

00227

Fig. 29—Spring-loaded Deflector

- Use the strap on the end of the bag to securely attach it to the chute.

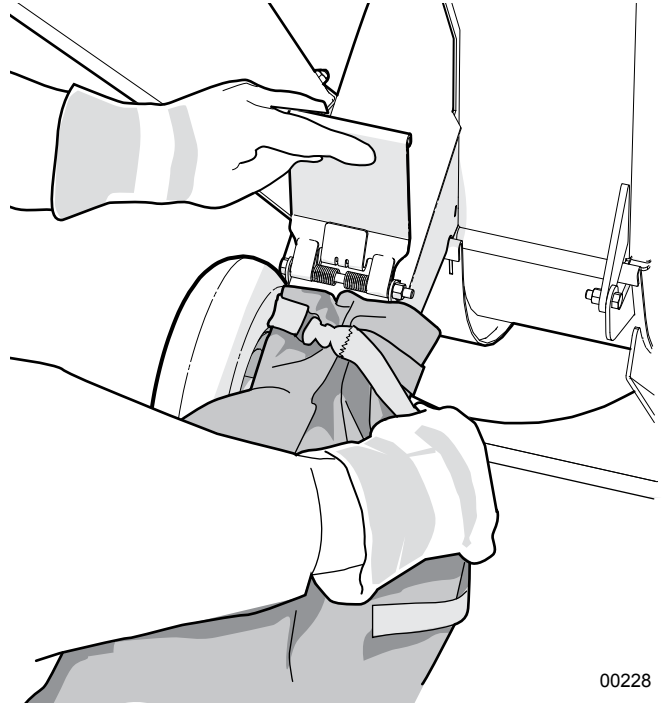

00228

Fig. 30—Installing Collector Bag

- When full, loosen the strap and remove the bag from the chute to empty it.
- Unzip the bottom of the bag to spread the chips and mulch over the desired area.

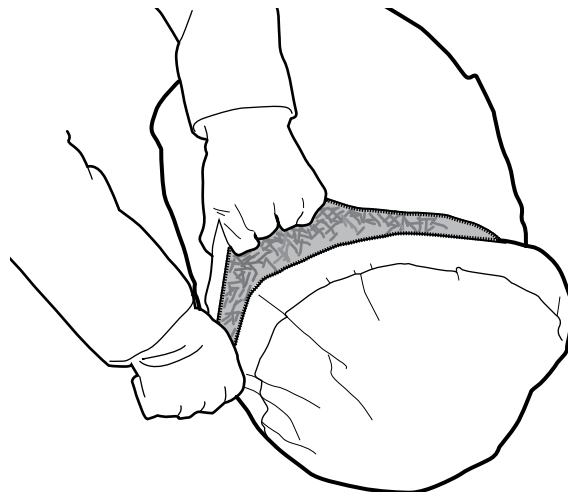

00229

Fig. 31—Emptying Collector Bag

- Zip up the end of the bag and re-attach it to the discharge chute.

Operating without a Collector Bag

The BXMC34B and BXMC3409B models can be used without a collector bag.

- Be sure that the deflector is down, so the mulch is directed to the ground.
- Position the chipper at the work site so the mulched material is accessible.

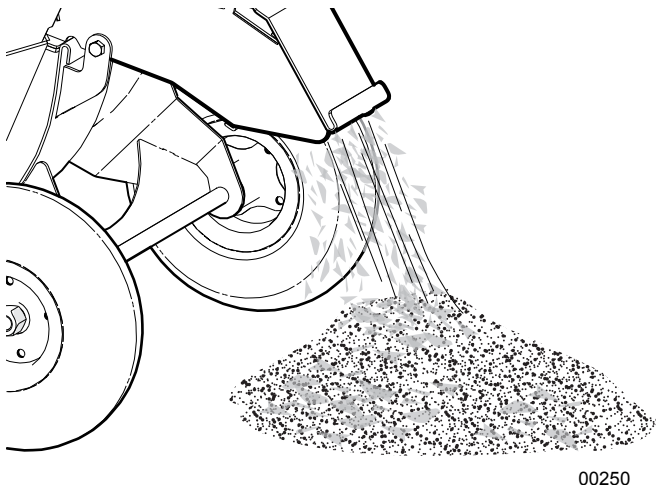

Fig. 32—Using Chipper without Collector Bag

6.15 Jockey Wheel

The BXMC34B and BXMC3409B models include a Jockey Wheel to make it easier to move the chipper around the site.

- The handle tips up when not in use.
- Wheels can be turned and locked, if working on an incline.
- Use the handle to tow the chipper around the work site with a garden tractor or ATV.

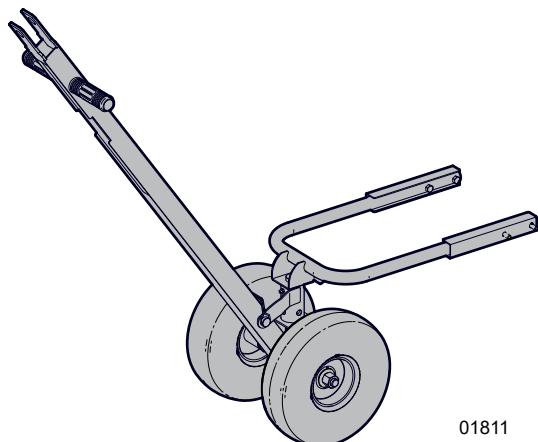

Fig. 33—Jockey Wheel

Remove the front leg support to install the Jockey Wheel. Use four of the support fasteners to connect it to the chipper frame.

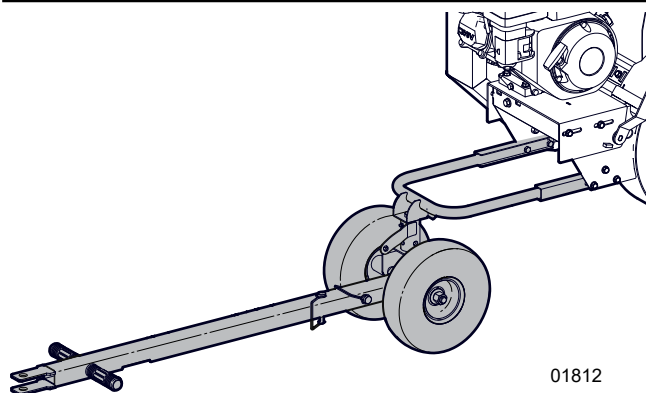

Fig. 34—Jockey Wheel Installation

6.16 Unplugging the Chipper

Although the machine is designed to handle a wide variety of material without any problem, occasionally it could plug up. If that happens, follow this procedure to clear it:

1. Turn the engine off and wait for all moving parts to stop.
2. Pull material out of the chipper and shredder feed hoppers. Make sure nothing is jammed or wedged between the input opening and the rotor.
3. On the BXMC34B / BXMC3409B models, pull the material out of the discharge chute as well. Use a stick to poke loose any material jammed into the discharge chute.
4. On the BXMC34S / BXMC3409S models, tilt the chipper backwards and remove all the material on the underside from the screen.
5. Start the engine, engage the drive system and check to see if the jam is cleared.

Jam not Cleared

6. Turn the engine off and wait for all moving parts to stop.
7. Remove the two upper rotor housing bolts (1) and carefully open the housing (2).
8. Remove material from inside the rotor compartment.

CAUTION!

Avoid reaching into rotor compartment. Rotor chipper blades are very sharp. If reaching inside is necessary, use extreme care.

W003

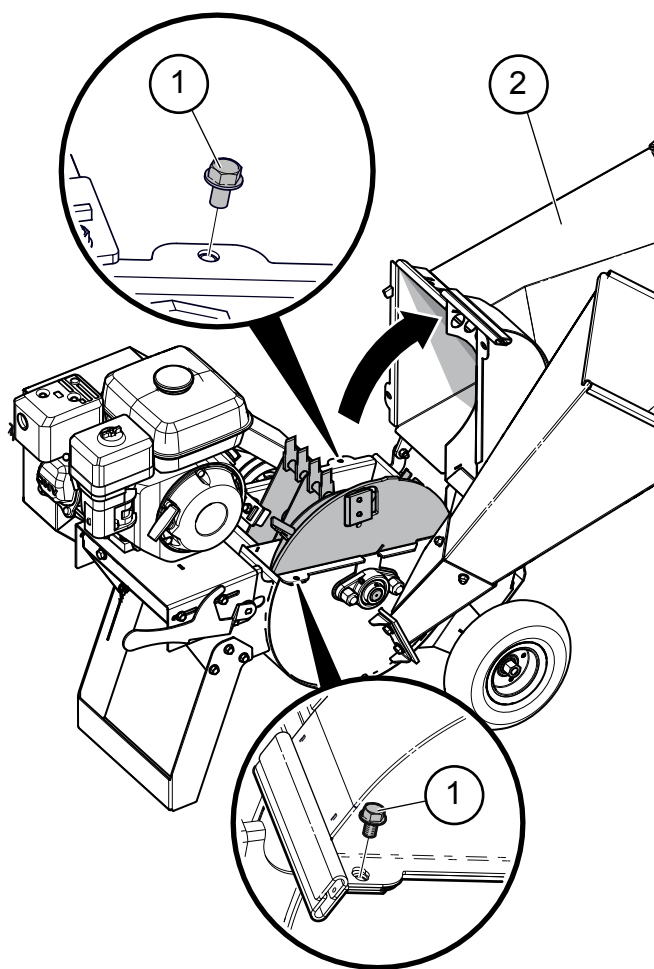

Fig. 35—Opening Upper Rotor Housing

1. Upper Rotor Housing Bolts
2. Upper Rotor Housing

9. Clean out the discharge area, rotor and screen.
10. If required, rotate the rotor **very carefully** and slowly by hand to be sure there is nothing jammed between the rotor and stationary blades. **Do not reach into the rotor housing if the rotor is moving.**

11. Close and secure rotor cover. Tighten fasteners to their specified torque.
12. Start the engine. Engage the drive system and verify material is cleared before resuming.

6.17 Placing Chipper in Storage

After the season's use or when the machine is going to be put away in storage, it should be thoroughly inspected and prepared. Replace or repair any worn or damaged components to prevent any unnecessary down time at the beginning of the next season.

Store the chipper in an area away from human activity. It is best to store the machine indoors. If that is not possible, cover it with a water-proof tarp.

IMPORTANT! Review the engine owner's manual to prepare the engine for storage.

Follow this procedure before storing:

1. Clear all material from the machine.
2. On BXMC34B and BXMC3409B models, remove collector bag, if installed. Wash it and store in a dry location.
3. Thoroughly clean the machine to remove all dirt, mud and debris.
4. Lubricate the rotor bearings to remove any water residue from washing.
5. Inspect all rotating parts and remove any entangled material.
6. Add fuel stabilizer to the fuel tank. Start the engine and leave it operating for a few minutes to make sure the treatment gets throughout the fuel system.
7. Engage the drive system and let it run a few minutes to dry any moisture inside the machine from washing.
8. Fill the fuel tank to prevent condensation. Check the engine manual for any additional storage requirements.
9. Turn the fuel valve off.
10. Touch up all paint nicks and scratches to prevent rusting.

6.17.1 Removing from Storage

1. Check through the measures listed in the Pre-operation Checklist. See *page 24*.
2. Review the Operating Safety on *page 9*.
3. Turn the fuel valve on.

7. Service and Maintenance

WARNING!

Risk of serious personal injury. Stop engine before performing ANY service or maintenance procedure. Reinstall all covers and shields removed before putting machine back into service.

W033

WARNING!

Shut down the machine and allow it to cool before performing any service, maintenance, or inspection procedure. Engine components and oil may be hot enough to cause injury.

Make sure the machine is in a Safe Condition to work on. Review Maintenance Safety beforehand.

W041

IMPORTANT! Refer to the engine manufacturer's manual for maintenance and service information.

7.1 Fluids and Lubricants

1. Engine Oil

SAE 10W-30 motor oil is recommended for general use. Refer to the engine manufacturer's manual for additional information on engine oils.

2. Grease

Use an SAE multi-purpose high temperature grease with extreme pressure (EP) performance. Also acceptable is an SAE multipurpose lithium-based grease.

3. Engine Fuel

This engine is certified to operate on unleaded gasoline with a pump octane rating of 86 or higher (a research octane rating of 91 or higher). Refer to the engine manufacturer's manual for additional information on engine fuels.

4. Storing Lubricants

Your machine can operate at top efficiency only if clean lubricants are used. Use clean containers to handle all lubricants. Store them in an area protected from dust, moisture and other contaminants.

7.2 Maintenance Schedule

Perform maintenance procedures at time shown or hour interval, whichever comes first.

As Required

Visually check drive belt tension.

Remove entangled material from chipper.

Check that all fasteners are tight.

Every 8 hours or Daily

Check engine oil level. *See page 26*

Perform Pre-operation check. *See page 24*

Periodically inspect shredder blades, rotor blades, chop block, ledger knife, and (BXMC34B / BXMC3409B) twig breaker. —

Every 50 hours or Annually

Clean engine air filter. *See engine manual*

Check drive belt tension and sheave alignment. *See page 35*

Check rotor blade sharpness. *See page 38*

Check ledger knife sharpness. *See page 39*

Check twig breaker. *See page 41*

Every 100 hours or Annually

Change engine oil. *See engine manual*

Change engine air filter. *See engine manual*

Clean machine. Remove debris and entangled material. —

Change fuel filter. *See engine manual*

Grease rotor bearings. *See page 34*

7.3 Grease Points

Use a hand-held grease gun for all greasing. Pump one shot of grease per fitting.

- Wipe grease fitting with a clean cloth before greasing to avoid injecting dirt and grit.
- If fittings do not take grease, remove and clean them thoroughly. Replace grease fittings as necessary.

Location	Grease Points – Every 100 hours of operation or annually
1, 2	Rotor Main Shaft Bearings

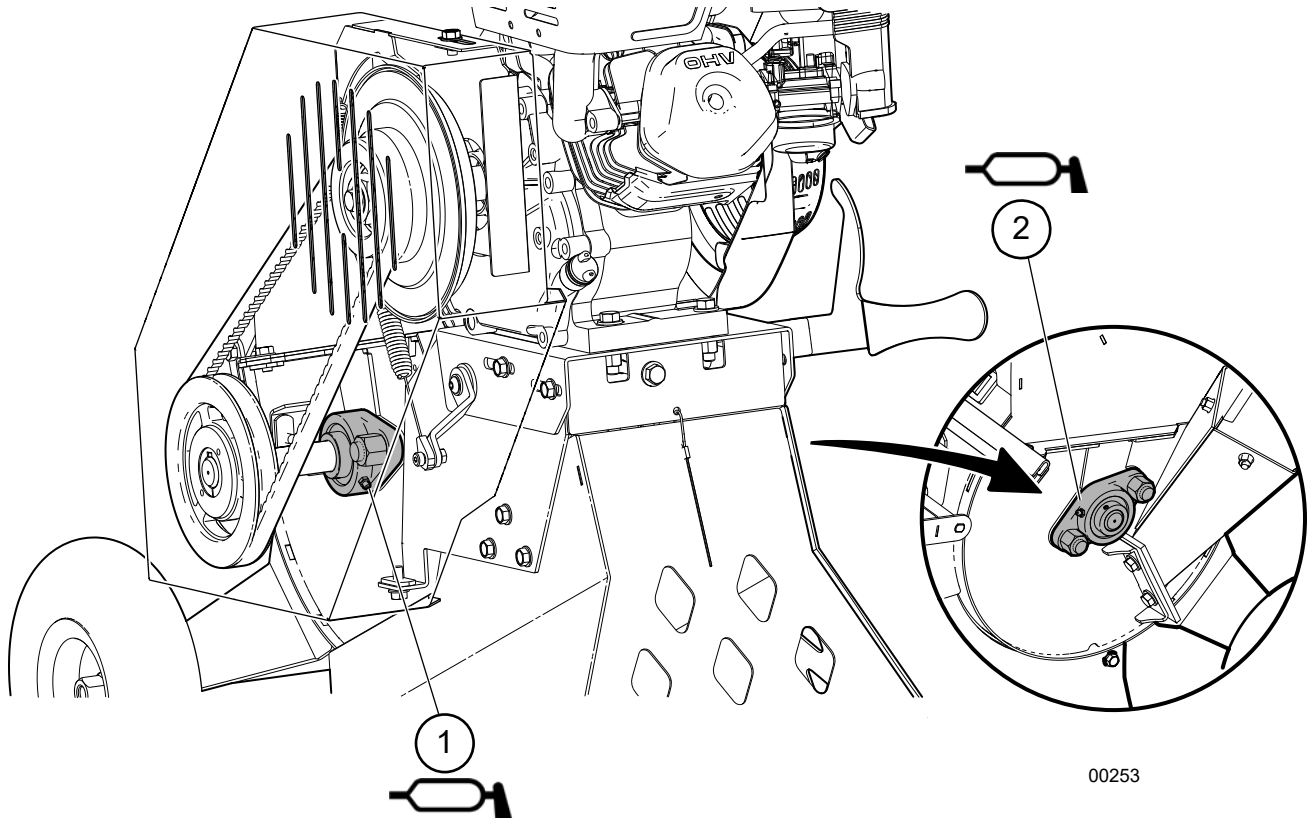

Fig. 36–Rotor Main Shaft Bearings

7.4 Drive Belt Replacement

The clutch on the engine shaft has an internal brake. When engaged, it brakes the engine pulley to stop the belt drive and rotor plate pulley. When the belt is in disrepair or loose, the ability to stop the rotor quickly may be affected. It is important to periodically check belt tension and condition. **Frayed, cracked or worn drive belts should be replaced.**

IMPORTANT! If changing or removing drive belt, always set correct belt tension. Make sure engine and rotor sheaves align properly.

Check drive belt tension every 100 hours of operation.

Make sure the engine is off and components are cool to touch beforehand.

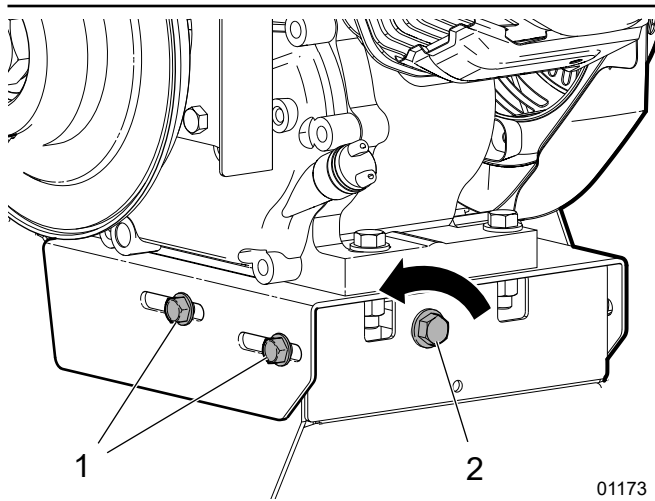

Fig. 37—Engine Mount

1. Engine Mount Bolts
2. Belt Tension Adjuster

1. Remove the drive belt shield.
2. Loosen the four bolts (1) that hold the engine mount to the main frame.
3. Turn the belt tensioning bolt (2) counterclockwise to loosen the belt. Slide the engine back and remove the belt.
4. Install the new belt, slide the engine forward, and set correct drive belt tension. See *Tensioning Drive Belt* to follow.

IMPORTANT! Check sheave alignment after changing the drive belt.

BXMC34S, BXMC34B Models

These machines are equipped with the Honda® GX200 engine, and the clutch/brake actuator assembly must be removed to replace the drive belt.

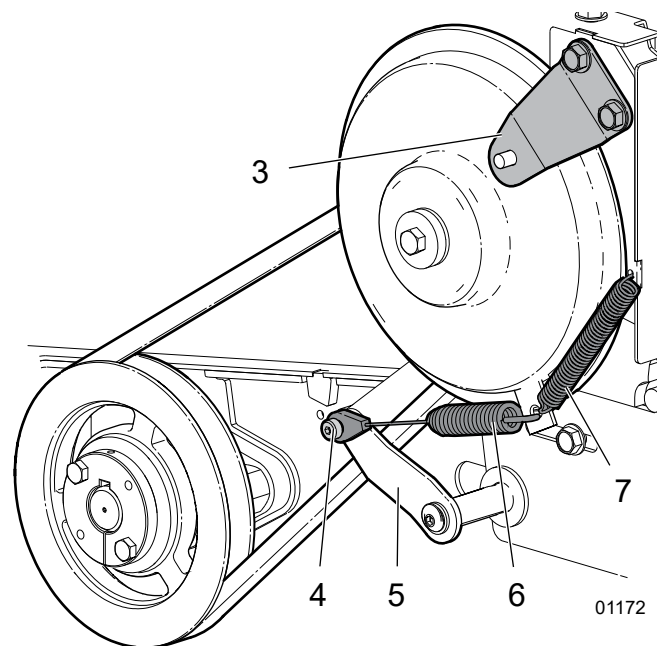

Fig. 38—Clutch/brake Actuator

1. Remove the clutch keep (3) from the shield mount.
2. Remove the shoulder bolt (4) from the actuator foot (5). Unhook from brake / clutch actuator cable (6).
3. Unhook the return spring (7) from the shield mount and brake / clutch.
4. Remove the old belt off the rotor sheave-end first, then the brake / clutch end. Install the new belt in the reverse order.
5. Install the clutch keep (3) and bolts. Make sure the peg on the brake clutch is in the slot in the clutch keep.
6. Install the new belt and slide the engine forward. See *Tensioning* to follow.

IMPORTANT! Check sheave alignment after changing the drive belt.

7.5 Drive Belt, Tensioning

Drive belt deflection should be no more than 1/4"–3/8" (6 mm–10 mm).

For accurate measurement use a drive belt tension gauge. If one is not available, the following method can be used.

1. Push on the drive belt by hand to check its deflection. Correct belt deflection is 1/4"–3/8" (6 mm–10 mm).

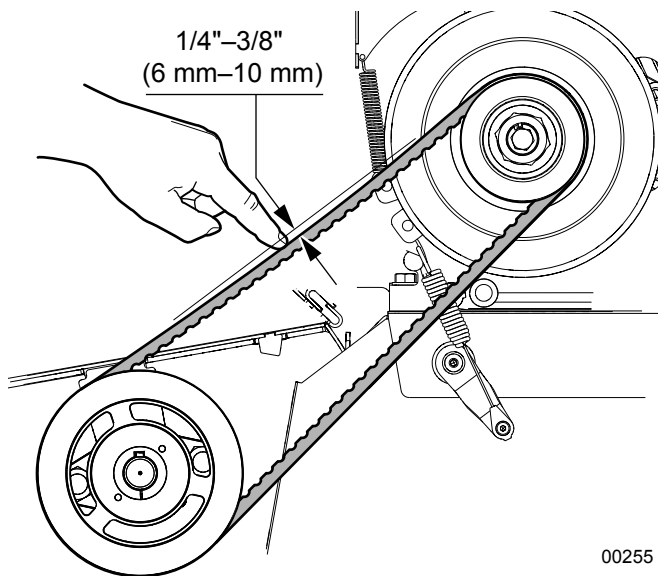

Fig. 39—Checking Drive Belt Tension

2. If the belt requires adjustment, loosen (do not remove) the four bolts that hold the engine mount to the main frame (1).

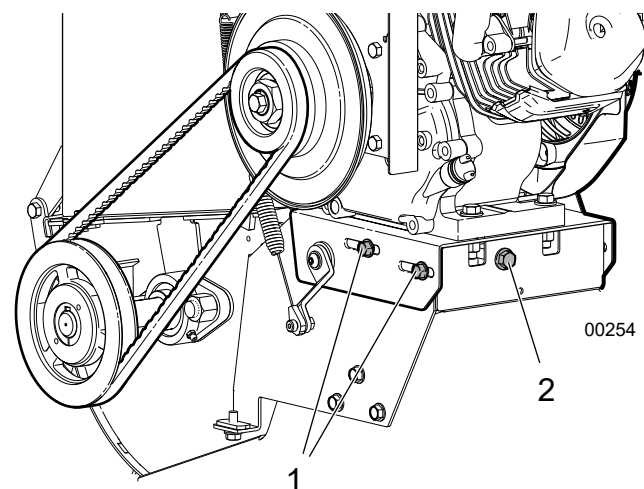

Fig. 40—Drive belt Tension Adjustment

1. Engine Mount Bolts
2. Belt Tension Adjuster Bolt

3. Pull the engine back to snug up the belt, then tighten the bolts on the opposite side from the belt.
4. Turn the belt tension adjuster bolt (2) clockwise to tighten the belt. Turn it counterclockwise to loosen the belt. Check and adjust belt tension accordingly. Be aware of belt alignment when adjusting belt tension. See *Drive Belt Alignment* to follow.
5. Recheck belt tension. Once set correctly, tighten up all four engine mount bolts. Re-install the belt shield.
6. Recheck belt tension after 10 hours of operation.

7.6 Drive Belt Alignment

Observe drive belt alignment every 8 hours of operation.

Belt misalignment can occur from incorrect sheave offset or sheave angle misalignment.

Sheave *angle* adjustment can only be corrected on the engine shaft sheave. Sheave *offset* adjustment is done on the rotor sheave. Make your adjustment as accurate as possible. For accurate measurements use a laser alignment tool. If one is not available, the following method can be used.

Place a straight edge along the front face of the rotor sheave and engine clutch sheave. The gap between the drive belt along the length of the straight edge must be equal. Adjust accordingly.

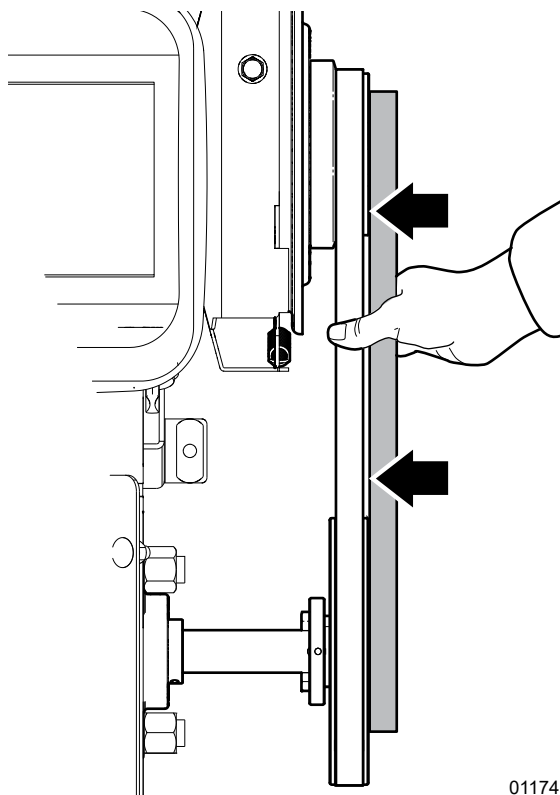

Fig. 41—Sheave Alignment

If the gap is not even along the length of the belt, determine whether the engine is square to the chipper frame. It may also be that the rotor sheave has moved in or out on the shaft.

7.6.1 Sheave Angle Misalignment

After changing the drive belt, the angle of the engine mount can shift resulting in poor belt alignment.

Maximum sheave angle misalignment is 0.5 degrees.

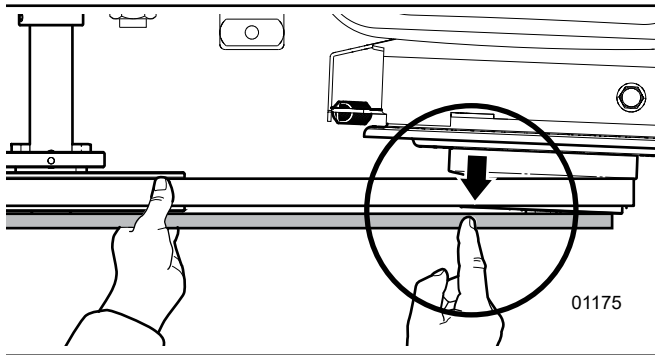

Fig. 42—Engine Mount Misalignment

1. First, make sure the bolts fastening the engine to the mount are tight. Make sure the engine is square to the base and the bolts are properly torqued to **33 lbf•ft (45 N•m)**.

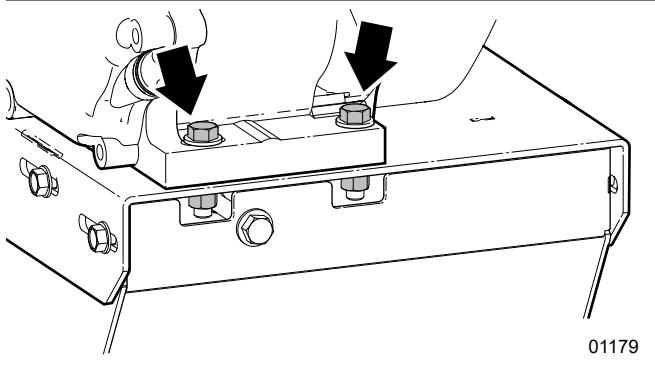

Fig. 43—Engine bolts

2. If the engine is sitting squarely on the base plate, loosen the four mounting bolts.

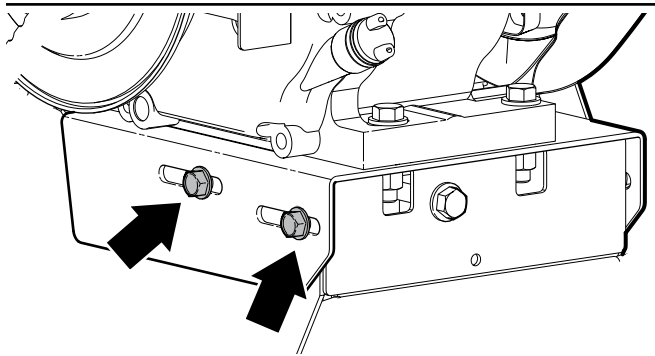

Fig. 44—Engine Mount Bolts

3. Slide the plate until the belt is snug, but not tight. Hand-tighten the bolts on one side.
4. Use the belt tension adjuster to pull the engine one way or the other. Recheck sheave alignment after each adjustment. Tighten the last two bolts when alignment is correct.

7.6.2 Rotor Sheave Offset Adjustment

The maximum offset misalignment is 1/32" (1 mm).

If the rotor sheave loosens on the shaft, it can become misaligned with the engine clutch, resulting in poor belt alignment.

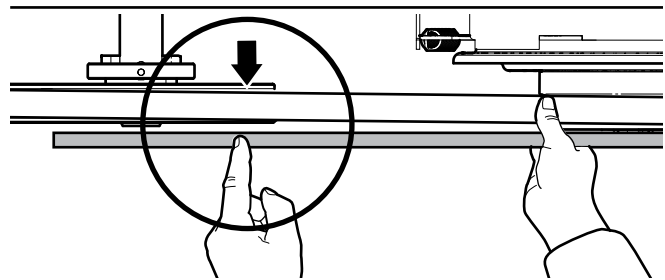
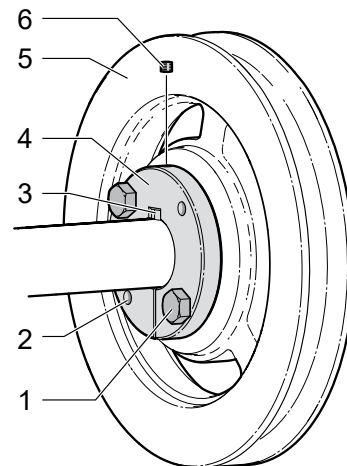

Fig. 45—Rotor Sheave Misalignment

1. Remove the drive belt.



01178

Fig. 46—Rotor Sheave

- | | |
|--------------------------|---------------|
| 1. Sheave Bolts | 4. Sheave Hub |
| 2. Threaded Puller Holes | 5. Sheave |
| 3. Shaft key | 6. Set Screw |
2. Remove the set screw from the sheave (5).
 3. Remove the sheave bolts (1) and thread them into the puller holes on the tapered sheave hub (2).
 4. Turn in the bolts evenly in 1/4-turn increments to pull the hub and the sheave slightly apart so they can move on the shaft.

5. Lightly tap the sheave hub with a block of wood to move it in or out on the shaft so it is re-aligned with engine clutch sheave. Confirm with the straight edge along the face of the engine clutch and rotor sheave.
6. Once aligned, insert the hub bolts and snug them up to the sheave. Recheck alignment.
7. Tighten hub bolts evenly in 1/4-turn increments until firmly seated. Install and tighten the set screw.
8. Re-check the alignment again with the straight edge once the bolts are tight. Re-check belt tension.
9. Reinstall the guard.

7.7 Rotor Blades – Checking

Observe rotor blade performance daily. Check sharpness every 50 hours.

The rotor is equipped with two opposing blades. The rotor blades shear material off as they rotate past the stationary ledger knife. Keep the blades sharp for optimum performance. Sharp blades reduce the amount of power required during operation. Periodic inspection is recommended.

 **NOTE:** Check the sharpness of the knives more frequently if processing material with a lot of sand, soil or grit in it. Reverse or sharpen the knives if performance diminishes. If sharpening or replacing a blade, do the opposing one as well.

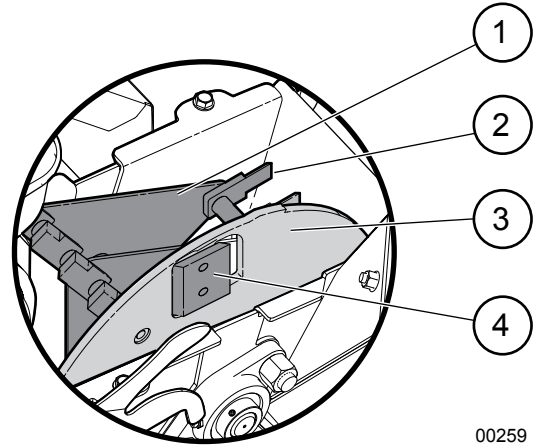

00259

Fig. 47 – Rotor

1. Shredder
2. Shredder Knives
3. Rotor
4. Rotor Blades

WARNING!

Machine shown with shields removed for illustrative purposes only. Never operate machine with shields removed.

W001

Remove the blades from the rotor to sharpen them. Always sharpen the blade edge at a 45° angle to provide the best cutting effect as the rotor turns.

7.8 Rotor Blades – Changing

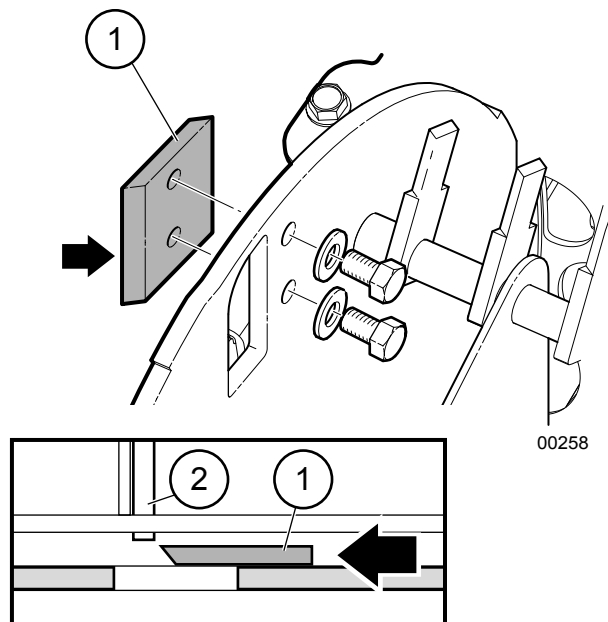

Fig. 48– Sharpening / Changing Rotor Blades

1. Rotor Blade
2. Ledger Knife

Procedure

1. Open the rotor housing to manually rotate the rotor plate so one of the blades is accessible. Rotating the rotor requires lifting the clutch lever off the brake position slightly.

NOTE: *Rotating the rotor requires lifting the clutch lever off the brake position slightly. Brake should be re-engaged to lock rotor before attempting to loosen bolts.*

2. Release the clutch lever so the brake engages to lock the rotor. Remove the bolts and the blade.
3. Lift the clutch lever off the brake position slightly to rotate the rotor and remove the other one.
4. If sharpening the blades, sharpen both evenly. Sharpen or rotate each in the same manner. If a blade needs to be replaced, replace both blades.

IMPORTANT! Treat both blades equally to help the rotor stay balanced as it turns.

5. Install the blades with the leading edge out. Apply blue Loctite® to the bolt threads and torque-tighten bolts to **47 lbf•ft (66 N•m)**.

7.9 Ledger Knife – Clearance

Observe ledger knife performance daily. Check sharpness every 50 hours.

The ledger knife is bolted inside the lower rotor housing assembly. As the rotor turns, material fed into the chipper is sheared off at the ledger knife by the rotor blades. Sharp knives provide optimum performance and reduce the amount of power required during operation. Periodic inspection is recommended.

When the corner of the ledger knife facing the rotor blade rounds over, the blade can be removed and re-installed with a different corner facing the rotor blade. Once all four corners have been rounded, remove the knife to sharpen or replace it.

The clearance between the rotor blades and the ledger knife should be kept at 1/32–1/16" (.76–1.52 mm) to obtain the best performance.

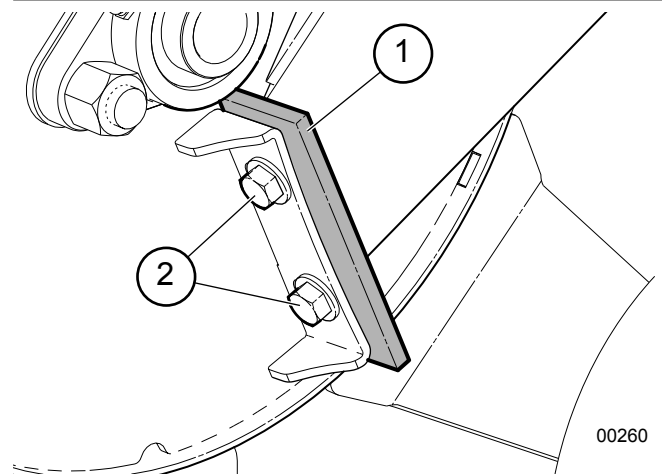

Fig. 49– Ledger Knife in Lower Rotor Housing

1. Ledger knife
2. Mounting Bolts / Washers

7.10 Ledger Knife – Adjusting

Procedure

1. Remove the ledger knife from the chipper and turn, rotate, or sharpen it.

NOTE: *If the ledger knife is worn enough that the proper clearance cannot be set, replace it.*

2. Apply blue Loctite® to the bolt threads and install the ledger knife. Hand-tighten the bolts for now.
3. Set the clearance between the ledger and rotor blades from 1/32–1/16" (.76–1.52 mm).

 **NOTE:** A Ledger Clearance Setting Gauge is available from your dealer to make this task easier.

4. Torque-tighten bolts to **47 lbf•ft (66 N•m)**.

7.11 Shredder Knives – Changing

The shredder rotor has three sets of swinging knives mounted on it. Each knife has a beveled edge that cuts, chops and mulches the material as it moves around the rotor compartment. As the knives pass the chop block, the material is mulched.

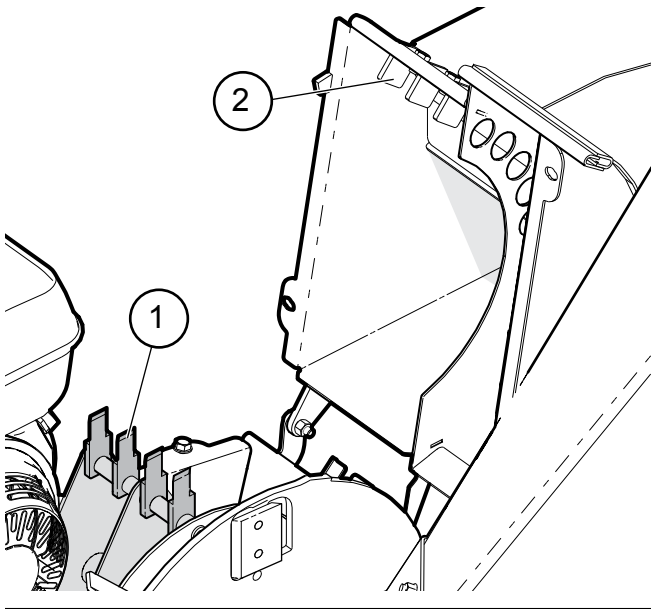

Fig. 50 – Shredder Knives and Chop Block

1. Shredder Knives
2. Chop Block

On the BXMC34B and BXMC3409B models, four holes in the divider at the top of the rotor keep the material inside the rotor housing until it becomes fine enough to move through the holes to the rotor paddles and expelled out the discharge chute.

On the BXMC34S and BXMC3409S models, the material stays in the rotor housing until it is fine enough to escape through the holes in the screen at the bottom of the rotor frame.

Shredder knives can be reversed when dull or removed and sharpened. If the knives are damaged or cannot be sharpened, they should be replaced.

Sharp knives provide optimum performance and reduce the amount of power required during operation. Periodic inspection is recommended.

Procedure

1. Open the rotor housing and manually rotate chipper rotor plate so that one set of shredder knives is fully exposed.
2. Loosen the through bolt that holds the set of shredder knives and spacers to the shredder plate.
3. Slowly remove the bolt and catch the knives and spacers as they become free.
4. Reverse the knife and replace or replace with new or re-sharpened knives.

IMPORTANT! Make sure the knives and spacers are installed in the correct manner. Improper installation decreases performance of the shredder.

5. Apply blue Loctite to the threads of the through bolt. Torque-tighten bolts to **47 lbf•ft (66 N•m)**.
6. Repeat steps for second and third sets of shredder knives.

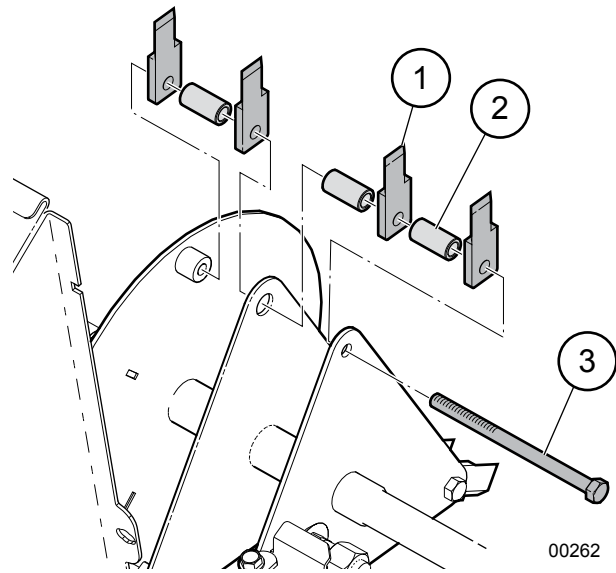

Fig. 51 – Shredder Knives

1. Shredder Knives
2. Spacers
3. Through Bolt

7.12 Chop Block

The Chop Block is bolted on at the bottom of the upper rotor housing. As the shredder knives pass through the chop block, the tabs break material into smaller pieces and turn it into mulch.

When inspecting the chop block, look for damage such as gouges, bent, or missing teeth. A damaged chop block should be replaced. If teeth are showing wear, remove the chop block, rotate it and install it so the teeth wear on the other side.

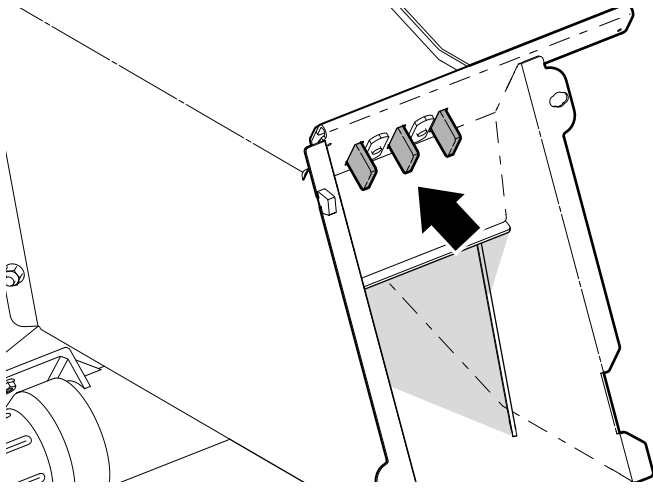

Fig. 52 – Chop Block on Upper Rotor Housing

7.13 Twig Breaker

(BXMC34B, BXMC3409B only)

The Twig Breaker is bolted on the discharge chute, beside the upper rotor housing. As the discharge paddles pass around by the twig breaker, material is further broken up as it exits the discharge chute.

When inspecting the twig breaker, look for damage such as gouges, a bent, or missing tooth. A damaged twig breaker should be replaced. If the twig breaker tooth is showing wear, remove it and rotate it around to wear on the other side.

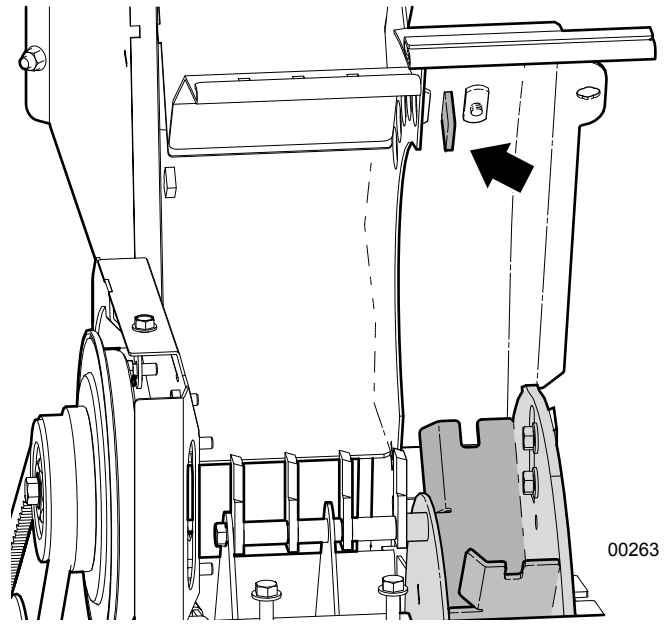

Fig. 53 – Twig Breaker

7.14 Mulching Screen

(BXMC34S, BXMC3409S only)

The BXMC34S and BXMC3409S models discharge material through the mulching screen in the bottom of the rotor frame. The screen retains the wood material inside the rotor chamber until it is small enough to exit through the holes and drop to the ground under the rotor.

The standard screen has 1-1/2" (38 mm) holes for general purpose mulching. Two optional screens are available:

- 3/4" (19 mm) holes for a finer mulch
- 1-1/2" x 7.0" (38 mm x 178 mm) slotted holes for wet material.

To change the mulching screen:

1. Carefully tilt the machine back, so the hoppers are resting on the ground and the bottom of the machine is exposed.
2. Remove the two mounting nuts and bolts that hold the screen into the bottom housing (2).
3. Pull the bottom of the screen outward and down to remove it.
4. Reverse steps to install.

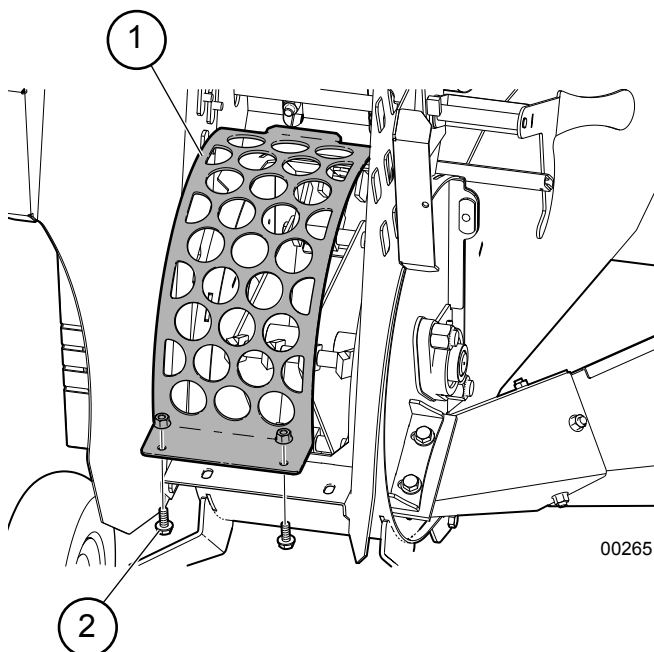

Fig. 54—Mulching Screen

1. Mulching Screen
2. Mounting Bolts

8. Troubleshooting

The following table lists some problems that may be encountered, with possible causes and solutions.

If a problem persists after reading through the Troubleshooting section, contact your local dealer, distributor or Wallenstein Equipment. Have the serial number ready.

Engine related issues

Refer to the engine owner's manual included in the manual tube.

Problem	Cause	Solution
Rotor does not turn.	Obstructed discharge.	Clear debris from discharge chute (BXMC34B and BXMC3409B) or material screen (BXMC34S and BXMC3409S).
	Rotor plugged.	Inspect and clear chipper hopper lower rotor housing and rotor.
	Loose belt.	Follow tension adjustment procedure and tighten belt.
	Brake clutch spring broken.	Remove belt shield and inspect.
	Broken belt.	See belt replacement procedure <i>page 35</i> .
Material feeding in too slow.	Engine or rotor speed too low.	Set throttle to increase rotor rpm.
	Blades or knives are dull or clearance incorrect.	Check rotor and ledger knives. Rotate, sharpen or replace.
	Rotor blade knife edge angle incorrect.	Re-sharpen rotor knives to specified 45° angle and check that blade is installed properly.
	Collector bag full.	Detach bag and empty.
	Screen plugged / discharge cage is full (BXMC34S and BXMC3409S)	Move chipper to new location and clear screen.
	Obstructed discharge.	Clear debris from discharge chute or material screen.
Unusual machine vibration while operating.	Broken or missing ledger knife or knife.	Inspect. Replace if damaged.
	Rotor may be bent.	Check for rotor wobble. Replace rotor.
Mulch size too coarse.	Chop block or twig breaker damaged.	Inspect. Replace if damaged.
	Broken or missing ledger knife or knife.	Replace.
	Knives in shredder improperly installed.	Check installation of knives and adjust as required. See <i>page 40</i> .
	Improper mulch screen installed.	Replace with properly sized screen.
Mulch too fine.	Improper mulch screen installed.	Replace with properly sized screen.
Machine requires excessive power or stalls.	Obstructed discharge.	Clear debris from discharge
	Clutch being engaged too quickly.	Engage clutch slowly. Make sure rotor housing and hoppers are clear before engaging.
	Collector bag full.	Detach and empty bag.
	Feeding in too much material.	Feed smaller amounts into shredder hopper.
	Feeding material too quickly.	Feed larger material slowly into chipper hopper.
	Rotor plugged.	Inspect and clear chipper hopper lower rotor housing and rotor.
	Green material does not discharge.	Allow material to dry or alternate between dry and wet material. On BXMC34S and BXMC3409S, use the wet material screen.
	Space between rotor blade and ledger knife too large.	Use ledger gauge tool to check clearance. See <i>page 39</i> .
	Dull blades.	Check rotor and ledger knives. Rotate, sharpen or replace. See <i>page 39</i> .
	Engine problem.	Refer to engine manufacturer's manual.

Problem	Cause	Solution
Noisy drive belt, premature wear.	Drive belts loose or worn.	Inspect drive belts. Adjust tension or replace if needed. See <i>page 35</i> .
	Wrong replacement belt.	Inspect drive belts. Replace. See <i>page 35</i> .
	Rotor plugged.	Inspect and clear chipper hopper, lower rotor housing, and rotor.
	Rotor bearings.	Check and replace if required.
Poor Chip Quality.	Dull blades.	Check rotor and ledger knives. Rotate, sharpen or replace. See <i>page 39</i>
	Drive belts loose or worn.	Inspect drive belts. Adjust or replace if needed. See <i>page 35</i> .
	Poor quality material.	Material is small or rotting. Mix with higher quality material.
	Knife clearance incorrect.	Check and adjust as required. See <i>page 40</i> .

9. Specifications

9.1 Machine Specifications¹

Model	BXMC34B	BXMC34S	BXMC3409B	BXMC3409S
Engine	Honda® GX200		Honda® GX270	
Horsepower	5.5 hp (4.1 kW) @ 3600 rpm		8.5 hp (6.3 kW) @ 3600 rpm	
Drive System	Brake-Clutch with Belt Drive			
Number Of Rotor Blades	2 Offset			
Blade Type	Hardened Tool Steel			
Number of Shredder Knives	12 (3 Sets of 4 knives)			
Shredder Knife Type	Hardened Steel			
Rotor Specifications	40 lb (18.2 kg) 16 in (406 mm)	28 lb (12.7 kg) 14 in (356 mm)	40 lb (18.2 kg) 16 in (406 mm)	28 lb (12.7 kg) 14 in (356 mm)
Feeding System	Manual – Chipper and Shredder Hopper			
Shredder Capacity	3-1/2 X 5 in Opening; 3/4 in Max Diameter Material (9 X 13 cm Opening; 19 mm Max Diameter Material)			
Chipper Capacity	6 X 7 in Opening; 3 in Max Diameter Material (15 X 18 cm Opening; 7.6 cm Max Diameter Material)			
Discharge	Blower Discharge	Bottom Discharge Screen 1-1/2 in (38 mm) Holes	Blower Discharge	Bottom Discharge Screen 1-1/2 in (38 mm) Holes
Machine Type	Consumer Yard Equipment			
Tires	4.10 X 3.5 Rubber			
Dimensions Length x Width x Height	43 x 40 x 49 in (110 x 102 x 125 cm)	43 x 38 x 47 in (110 x 97 x 120 cm)	45 x 39 x 49 in (114 x 99 x 125 cm)	45 x 37 x 47 in (114 x 94 x 120 cm)
Weight	270 lb (122.5 kg)	250 lb (114 kg)	295 Lb (134 kg)	275 Lb (125 kg)
Accessories	Garden Trailer Hitch			
	—	Discharge Screens – 3/4 in (19 mm) Round Holes; 1-1/2 x 7 in (38 mm x 178 mm) Slotted Holes	—	Discharge Screens – 3/4 in (19 mm) Round Holes; 1-1/2 x 7 in (38 mm x 178 mm) Slotted Holes
	Ledger Clearance Setting Gauge			

¹ Specifications subject to change without notice

9.2 Common Bolt Torque Values

Checking Bolt Torque

The tables shown give correct torque values for various bolts and capscrews. Tighten all bolts to the torque values specified in the table, unless indicated otherwise. Check tightness of bolts periodically.

IMPORTANT! If replacing hardware, use fasteners of the same grade.

IMPORTANT! Torque figures indicated in the table are for non-greased or non-oiled threads. Do not grease or oil threads unless indicated otherwise. When using a thread locker, increase torque values by 5%.

 **NOTE:** Bolt grades are identified by their head markings.

Imperial Bolt Torque Specifications						
Bolt Diameter	Torque Value					
	SAE Gr. 2		SAE Gr. 5		SAE Gr. 8	
	lbf•ft	N•m	lbf•ft	N•m	lbf•ft	N•m
1/4"	6	8	9	12	12	17
5/16"	10	13	19	25	27	36
3/8"	20	27	33	45	45	63
7/16"	30	41	53	72	75	100
1/2"	45	61	80	110	115	155
9/16"	60	95	115	155	165	220
5/8"	95	128	160	215	220	305
3/4"	165	225	290	390	400	540
7/8"	170	230	420	570	650	880
1"	225	345	630	850	970	1320



Metric Bolt Torque Specifications				
Bolt Diameter	Torque Value			
	Gr. 8.8		Gr. 10.9	
	lbf•ft	N•m	lbf•ft	N•m
M3	0.4	0.5	1.3	1.8
M4	2.2	3	3.3	4.5
M6	7	10	11	15
M8	18	25	26	35
M10	37	50	52	70
M12	66	90	92	125
M14	83	112	116	158
M16	166	225	229	310
M20	321	435	450	610
M30	1,103	1 495	1,550	2 100

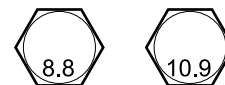

10. Accessories

Call your dealer for pricing and availability.

The parts manual for this product can be found at:
www.wallensteinequipment.com. Select *Manuals*, then Product Model and the document type.

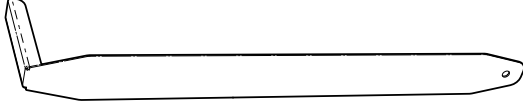
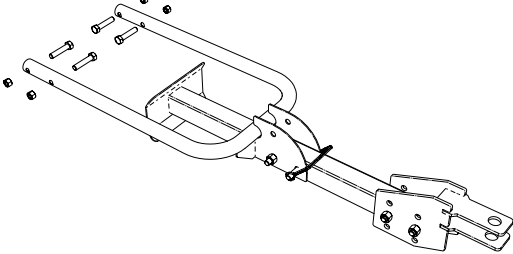
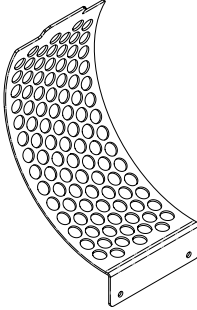
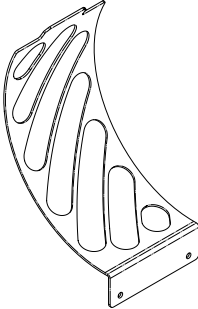
	<p>Ledger Clearance Setting Gauge – P/N 1012L269</p> <p>Used to set the critical clearances between the ledger knife and the rotor chipper blade.</p>
	<p>Garden Tractor Hitch – P/N 1082A355</p> <p>Used to tow the chipper around the work site with a garden tractor or ATV.</p>
	<p>Screen 3/4" (19 mm) Round Holes – P/N 1074L240</p> <p>For BXMC34S and BXMC3409S models only.</p> <p>Produces a finer mulch.</p>
	<p>Screen 1-1/2" x 7" (38 mm x 178 mm) Slotted Holes – P/N 1074L260</p> <p>For BXMC34S and BXMC3409S models only.</p> <p>Helps to prevent clogs when working with wet material.</p>

10.1 Warranty



LIMITED WARRANTY

Wallenstein products are warranted to be free of defects in materials and workmanship under normal use and service, for a period of

Five Years for Consumer Use

Two Years for Commercial/Rental Use

from the date of purchase, when operated and maintained in accordance with the operating and maintenance instructions supplied with the unit. Warranty is limited to the repair of the product and/or replacement of parts.

This warranty is extended only to the original purchaser and is not transferable.

Repairs must be done by an authorized dealer. Products will be returned to the dealer at the customer's expense. Include the original purchase receipt with any claim.

This warranty does not cover the following:

- 1) Normal maintenance or adjustments
- 2) Normal replacement of wearable and service parts
- 3) Consequential damage, indirect damage, or loss of profits
- 4) Damages resulting from:
 - Misuse, negligence, accident, theft or fire
 - Use of improper or insufficient fuel, fluids or lubricants
 - Use of parts or aftermarket accessories other than genuine Wallenstein parts
 - Modifications, alteration, tampering or improper repair performed by parties other than an authorized dealer
 - Any device or accessories installed by parties other than an authorized dealer
- 5) Engines. Engines are covered by the manufacturer of the engine for the warranty period they specify. For the details of your engine warranty, see your engine owner's manual. Information about engine warranty and service is also available in the FAQ section at www.wallensteinequipment.com

rev. Nov-2018

11. Alphabetical Index

A	
Accessories.....	47
Garden Tractor Hitch.....	47
Ledger Clearance Setting Gauge.....	47
Screen 1-1/2" x 7" (38 mm x 178 mm) Slotted Holes.....	47
Screen 3/4" (19 mm) Round Holes.....	47
B	
Before Starting the Engine.....	24
Bolt torque.....	46
Break-in.....	25
C	
Checking Bolt Torque.....	46
Chipper Severely Plugged.....	32
Chipping Operation.....	28
Choke Lever.....	21
Chop Block.....	41
Controls.....	21
Clutch Actuator Lever.....	23
Drive Position.....	23
Stop Position.....	23
Engine Controls.....	21
Choke Lever.....	21
Fuel Shut-off Valve.....	22
Ignition Switch.....	21
Throttle Lever.....	22
Shredder Hopper Flap.....	22
D	
Drive Belt Alignment.....	36
Drive Belt Replacement	
BXMC34S, BXMC34B Models.....	35
Drive Belt Alignment.....	36
Drive Belt, Tensioning.....	36
Drive Belt Tension.....	35
Drive Belt, Tensioning.....	36
E	
Engaging Drive.....	28
Engine.....	33
Engine Controls.....	21
Fuel Shut-off Valve.....	22
Ignition Switch.....	21
Recoil Starter.....	22
Throttle Lever.....	22
Engine Fuel.....	33
Engine Mount Misalignment.....	37
Engine Oil.....	33
Engine Oil Level Check.....	26
Equipment Safety Guidelines.....	8
F	
Familiarization.....	16
Job Site Familiarization.....	16
Machine Components.....	16
BXMC34B / BXMC3409B.....	17
BXMC34S / BXMC3409S.....	19
Operator Orientation.....	16
To the New Operator.....	16
Training.....	16
Fluids.....	33
Foreword	
Delivery Inspection Report.....	4
Types of Decals on the Machine.....	6
Fuel Level – Checking.....	25
Fuel Shut-off Valve.....	22
G	
Gas Motor Safety.....	10
Grease.....	33
Grease Points.....	34
I	
Ignition Switch.....	21
Informative Labels.....	6
Introduction.....	2
J	
Jockey Wheel.....	31
L	
Ledger Knife – Clearance.....	39
Lubricants.....	33
M	
Machine Components.....	16
Maintenance Decals.....	6
Maintenance Schedule.....	33
Moving the Chipper.....	29
Mulch Collector Bag.....	30
Mulching Screen.....	42
O	
Opening Upper Rotor Housing.....	32
Operating Safety.....	9
Operation.....	24
Before Starting the Engine.....	24
Chipper Plugged.....	31
Chipper Severely Plugged.....	32
Chipping Operation.....	28
Collector Bag.....	30
Engaging Drive.....	28
Engine Oil Level Check.....	26
Fuel Level Check.....	25
Jockey Wheel.....	31
Machine Break-In.....	25
Machine Set-up.....	26
Moving the Chipper.....	29
Placing Chipper in Storage.....	32
Pre-operation Checklist.....	25
Refueling.....	25
Removing from Storage.....	32
Shredding Operation.....	29
Starting the Engine.....	26
Stopping in an Emergency.....	27
Stopping Procedure.....	27
Unplugging the Chipper.....	31
Operator Orientation.....	16

P		Twig Breaker 41
Personal Protective Equipment (PPE) 8		
PPE 8		
Pre-operation Checklist 25		
Product Labels 6		
R		
Refueling 25		
Refueling Safety 10		
Replacing Damaged Safety Signs 15		
Rotor Blades 38		
Rotor Blades – Changing 39		
Rotor Sheave Misalignment 37		
S		
Safe Condition 8, 11, 24		
Safety 7		
Equipment Safety Guidelines 8		
Gas Motor Safety 10		
How to Install Safety Signs 15		
Maintenance Safety 11		
Operating Safety 9		
Personal Protective Equipment (PPE) 8		
Preparation 9		
Refueling Safety 10		
Safety Alert Symbol 7		
Safety Do's and Don'ts 8		
Safety Training 9		
Signal Words 7		
Transport Safety 10		
Safety Alert Symbol 7		
Safety Notice Labels 6		
Safety Signs 13		
Safety Sign Locations 13		
Safety signs, installing 15		
Safety Training 9		
Serial number 5		
Service and Maintenance 33		
Chop Block 41		
Drive Belt Tension 35		
Grease Points 34		
Ledger Knife – Adjusting 39		
Ledger Knife – Checking 39		
Maintenance Schedule 33		
Mulching Screen 42		
Rotor Blades – Changing 39		
Rotor Blades – Checking 38		
Sheave Alignment 36		
Shredder Knives – Changing 40		
Twig Breaker 41		
Shredder Hopper Flap 22		
Shredder Knives – Changing 40		
Shredding Operation 29		
Sign-off form 12		
Specifications 45		
Starter 22		
Starting the Engine 26		
Stopping in an Emergency 27		
Stopping procedure 27		
Storage 32		
T		
Troubleshooting 43		
		U
		Understanding Safety Decals 13
		Unplugging the Chipper 31
		W
		Warranty 48



A series of horizontal lines for writing, starting from the top of the page and extending downwards. The lines are evenly spaced and cover most of the page's width.

WALLENSTEIN