

# OPERATOR'S MANUAL

---

Serial number 1103118 and up

## WX15H / WX20H Log Splitter

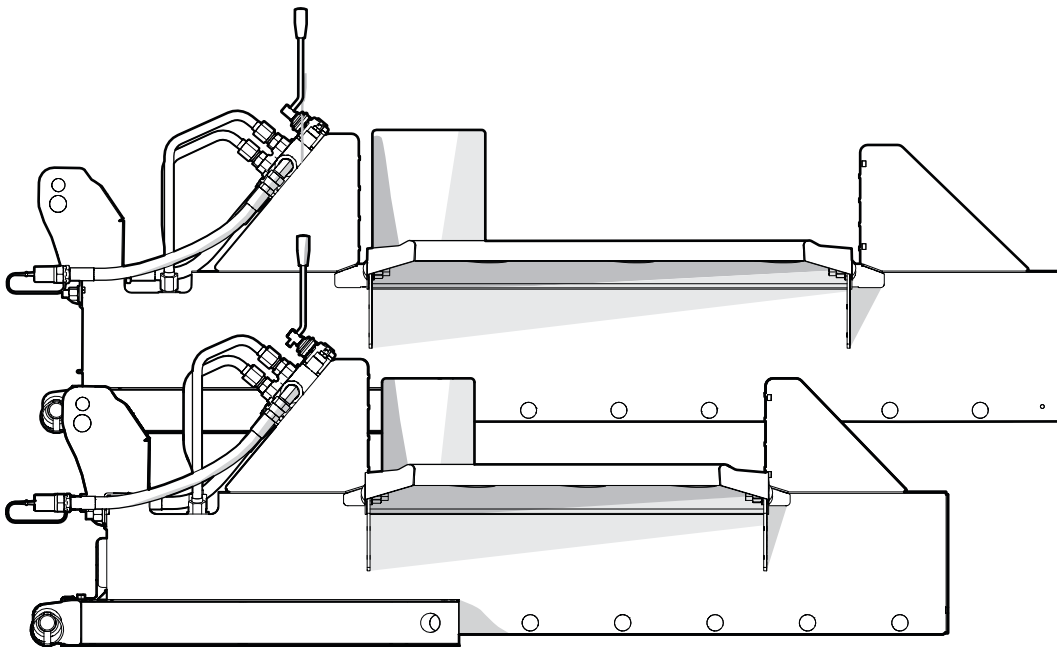

---

Revision: Oct-2024

Document Number: Z97170\_En

**WALLENSTEIN**

# Table of Contents

<b>1. Introduction .....</b>	<b>3</b>	<b>9. Service and Maintenance.....</b>	<b>31</b>
1.1 Delivery Inspection Report .....	4	9.1 Service and Maintenance Safety.....	31
1.2 Serial Number Location.....	5	9.2 Hydraulic System Maintenance Safety.....	32
1.3 Types of Labels on the Machine.....	6	9.3 Maintenance Schedule.....	33
<b>2. Safety .....</b>	<b>7</b>	9.4 Clean the Machine .....	33
2.1 Safety Alert Symbol .....	7	9.5 End of Service Life.....	33
2.2 Why Safety is Important.....	7	<b>10. Troubleshooting.....</b>	<b>34</b>
2.3 Signal Words .....	7	<b>11. Specifications .....</b>	<b>35</b>
2.4 Safety Rules .....	8	11.1 Machine Specifications.....	35
2.5 Equipment Safety Guidelines.....	9	11.2 Hydraulic System Specifications .....	35
2.6 Safe Condition .....	9	11.3 Bolt Torque.....	36
2.7 Safety Training.....	9	11.4 Hydraulic Fitting Torque .....	37
2.8 Training Record .....	10	<b>12. Warranty.....</b>	<b>38</b>
2.9 Work Site.....	11	<b>13. Index.....</b>	<b>39</b>
<b>3. Safety Labels .....</b>	<b>13</b>		
3.1 Replace a Safety Label.....	13		
3.2 Safety Label Locations.....	14		
3.3 Safety Label Definitions.....	16		
<b>4. Familiarization .....</b>	<b>18</b>		
4.1 New Operator .....	18		
4.2 Training .....	18		
4.3 Operator Orientation.....	18		
4.4 Machine Components.....	19		
<b>5. Controls .....</b>	<b>20</b>		
5.1 Splitter Control.....	20		
<b>6. Operation .....</b>	<b>21</b>		
6.1 Operation Safety .....	21		
6.2 Hydraulic System Operation Safety .....	22		
6.3 Pre-Start Checklist.....	23		
6.4 Machine Break-In.....	23		
6.5 Set Up the Machine.....	23		
6.6 Connect the Machine to a Tractor.....	24		
6.7 Disconnect the Machine from a Tractor .....	26		
6.8 Start the Machine.....	26		
6.9 Stop the Machine.....	26		
6.10 Emergency Stop .....	27		
6.11 Operate the Log Splitter.....	27		
<b>7. Transport.....</b>	<b>29</b>		
7.1 Transport Safety .....	29		
7.2 Prepare the Machine for Transport .....	29		
<b>8. Storage.....</b>	<b>30</b>		
8.1 Storage Safety .....	30		
8.2 Put the Machine in Storage .....	30		
8.3 Remove the Machine from Storage .....	30		

# 1. Introduction

## **WARNING!**

**Do not start or operate the machine before you read this manual. Make sure that you fully understand all the safety, operation, and maintenance information before you operate the machine.**

**Keep this manual with the machine at all times and available for frequent reference.**

W034

**IMPORTANT! The machine is only compatible with tractors that have an open-centre hydraulic system. If your tractor has a closed-centre hydraulic system, the machine needs a different valve. Contact your local Wallenstein dealer or Wallenstein Equipment.**

**Congratulations on your choice of a Wallenstein WX15H or WX20H Log Splitter!**

This high-quality machine is designed and manufactured to meet the needs of homeowners or small businesses.

WX15H and WX20H log splitters are tractor-mounted hydraulic-powered machines that are designed to split logs in two directions. The double-sided wedge can split a log when it extends and when it retracts, which increases productivity.

Model	Splitting force	Tractor compatibility
WX15V	15 tons	Category one or two (CAT I or CAT II)
WX20V	20 tons	Category one or two (CAT I or CAT II)

For safe, efficient, and problem-free operation of this Wallenstein Equipment product, make sure that everyone who uses or maintains the machine reads and understands the information in this manual and the tractor manufacturer's manual.

For information about the accessories, go to [WallensteinEquipment.com](http://WallensteinEquipment.com).

Keep this manual available for frequent reference and to give to new operators.

Units of measurement in Wallenstein technical manuals are written as: US Customary (SI metric)

For support or service, contact your local Wallenstein dealer or Wallenstein Equipment.

This manual is subject to change without notice. For the most current information, go to [WallensteinEquipment.com](http://WallensteinEquipment.com).

**Wallenstein Equipment Inc. • © 2024. All rights reserved.**

No part of this work may be copied, reproduced, replaced, distributed, published, displayed, modified, or transferred in any form or by any means except with the prior permission of Wallenstein Equipment Inc.



## 1.1 Delivery Inspection Report

### Wallenstein WX15H / WX20H Log Splitter

To register your product and start the warranty, go to [WallensteinEquipment.com](http://WallensteinEquipment.com).

This form must be completed by the dealer at the time of delivery, and then signed by the dealer and customer.

I received the product manuals and was thoroughly instructed about the care, adjustments, safe operation, and applicable warranty policy.

I thoroughly instructed the customer about the equipment care, adjustments, safe operation, and applicable warranty policy, and reviewed the manuals with them.

Customer

Dealer

Address

Address

City, State/Province, ZIP/Postal Code

City, State/Province, ZIP/Postal Code

( )

( )

Phone Number

Phone Number

Contact Name

Model

Serial Number

Delivery date

### Dealer Inspection Checklist

- \_\_\_\_\_ Three-point hitch connects to the tractor correctly.
- \_\_\_\_\_ Machine controls function correctly.
- \_\_\_\_\_ All fasteners are torqued to the correct specifications.
- \_\_\_\_\_ Hydraulic system and cylinders function correctly.
- \_\_\_\_\_ Hydraulic controls move freely.
- \_\_\_\_\_ Hydraulic connections are tight, and tubes, hoses, and fittings are in good condition.
- \_\_\_\_\_ There are no hydraulic leaks.
- \_\_\_\_\_ Operator's Manual is in the document tube.
- \_\_\_\_\_ Purchased accessories are included, if applicable.

### Safety Checks

- \_\_\_\_\_ All safety labels are applied and legible.
- \_\_\_\_\_ All guards and shields are installed.
- \_\_\_\_\_ A retainer (linchpin) is installed through each hitch connection.
- \_\_\_\_\_ Operation and safety instructions were reviewed.

## 1.2 Serial Number Location

Always provide the model and serial number of your Wallenstein product when you order parts, or request service or other information. The product information plate location is shown in the following illustration.

**Record the model and serial number of your product here:**

<b>Model</b>	
<b>Serial Number</b>	

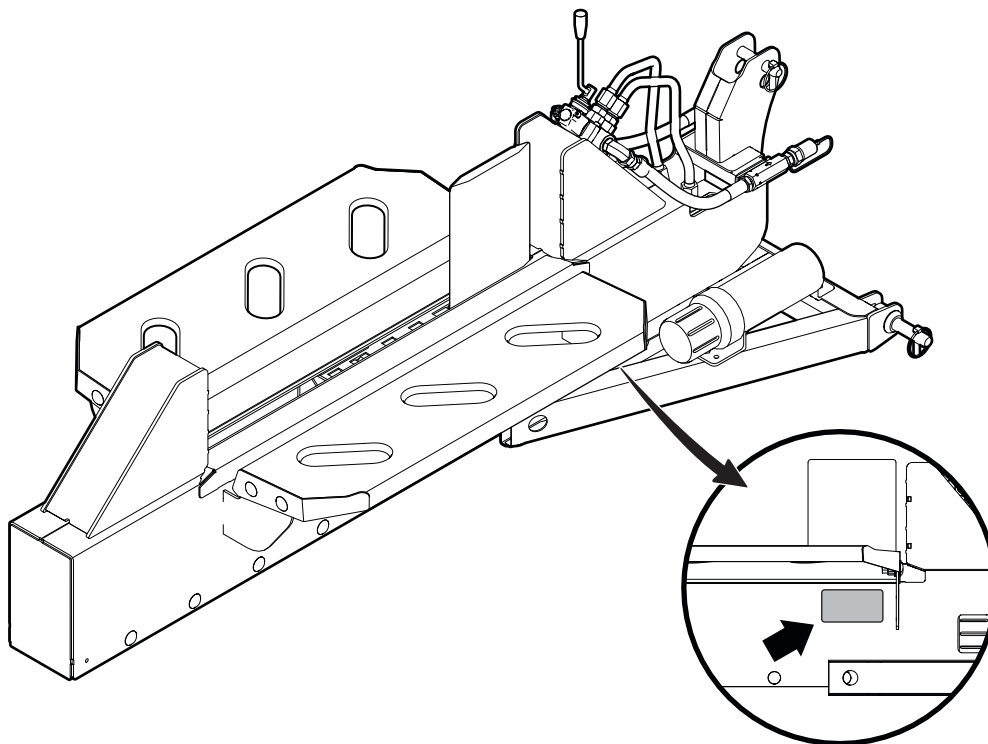
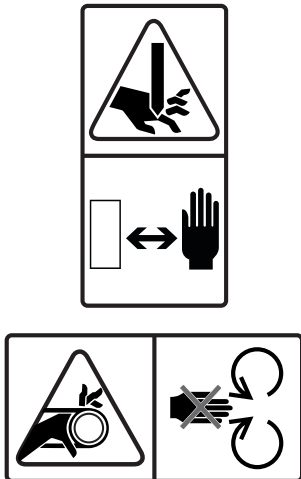

**Figure 1** – Product identification plate location (typical)

## 1.3 Types of Labels on the Machine

There are different types of labels on your Wallenstein product. The labels are for safety, information, and product identification. This section explains what the labels are for and how to read them.

**Safety labels** are pictorial with a yellow background and have two panels. They can be vertical or horizontal.



**Mandatory action labels** are pictorial with a blue background and usually rectangular with single or multiple symbols. This label shows the type of personal protective equipment (PPE) that is necessary for safe operation.



**Information labels** are usually pictorial with a white or black background and the number of panels can be different. This type of label gives the operator information or shows the operation of a control.

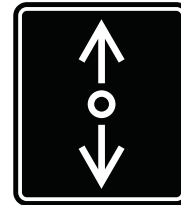

**Product labels** show the machine model and serial number. For more product information, scan the quick response (QR) code.



**Maintenance labels** have a green background and the number of panels can be different. This label shows the type of maintenance and how frequently it is necessary.

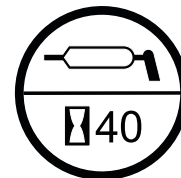

For safety label definitions, see *Safety Label Definitions* on page 16. For a complete illustration of labels and label locations, download the parts manual for your Wallenstein product at [WallensteinEquipment.com](http://WallensteinEquipment.com).

## 2. Safety

Read and make sure that you fully understand all the safety information before you operate, service, or maintain a machine.

### 2.1 Safety Alert Symbol

Look for this safety alert symbol on the machine and in the machine information.



When you see this symbol, it means:

**There is a hazard! Be careful!**  
**Your safety is involved!**

The safety alert symbol identifies important safety messages that you need to understand. Safety messages show or tell you about hazards that can or will make you ill, cause you serious injury, or kill you. **Always obey the instructions in a safety message.**

### 2.2 Why Safety is Important

- **Accidents disable and kill people.**
- **Accidents cost money.**
- **Accidents are preventable.**

**You** are responsible for the safe operation and maintenance of your Wallenstein Equipment product. **You** must make sure that you and anyone who uses, maintains, or works around the machine is familiar with the operation and maintenance procedures and related **safety information** in this manual. Obey the safety best practices in this manual when you operate or maintain your machine.

**You** are responsible for your own safety and the safety of the people around you. Most accidents can be prevented. **Do not ignore safety instructions and best practices.**

### 2.3 Signal Words

The signal words **DANGER**, **WARNING** and **CAUTION** identify the severity of a hazard to anyone who uses the machine. The applicable signal word for each message is selected based on the following guidelines:

#### DANGER

Identifies a hazardous situation that, if not avoided, **will** result in serious injury or death. This signal word is used to tell anyone who uses the machine about the most hazardous situations and machine components that cannot be guarded against.

#### WARNING

Identifies a hazardous situation that, if not avoided, **can** result in serious injury or death. This signal word includes hazards that occur when guards are removed and can be used to tell anyone who uses the machine about unsafe practices.

#### CAUTION

Identifies a hazardous situation that, if not avoided, **can** result in minor or moderate injury. It can also be used to tell anyone who uses the machine about unsafe practices.

**IMPORTANT** – Identifies a situation that could result in damage to the machine or property but is not a personal injury hazard.



---

Provides additional information that is helpful.

---

## 2.4 Safety Rules

### **WARNING!**

**Put on the necessary hearing protection before you operate the machine. Long exposure to loud noise can cause permanent hearing loss.**

W016

Wallenstein Equipment puts considerable effort into designing products that are safe to use; however, it is also the responsibility of the operator to use the equipment safely.

For safety information that is specific to machine operation, service, or maintenance, see the applicable section in this manual.

- It is the operator's responsibility to read, understand, and follow ALL safety and operation instructions in this manual.
- If you do not understand any part of this manual or need assistance, contact your local Wallenstein dealer or Wallenstein Equipment.
- Do not let anyone use this machine before they read this manual. The operator must fully understand the safety precautions and how the machine operates. Review the safety instructions with all the operators annually.
- Operators must be responsible, physically able, and know how to use the machine. Each operator must be trained before they use the machine. Before operation, evaluate the physical and/or mental limitations of each operator to make sure that they can use the machine safely. Do not let a child operate the machine.
- Make sure that all users understand the safety labels on the machine before they operate, service, adjust, or clean it. For safety label definitions, see *Safety Label Definitions on page 16*.
- Learn the controls and how to stop the machine quickly in an emergency. For instructions, see *Emergency Stop on page 27*.
- Keep a first-aid kit available and know how to use the contents of it.
- Keep a fire extinguisher available and know how to use it.



- Put on the applicable PPE before you operate, service, or maintain the machine. This includes, but is not limited to:
  - Heavy gloves.
  - Hearing protection.
  - Protective goggles and/or a face shield.
  - Protective shoes with steel toes and slip resistant soles.
- Long exposure to loud noise can cause permanent hearing loss. Power equipment, with or without a vehicle attached, can make a quantity of noise that is sufficient to cause permanent, partial hearing loss.
- Put on hearing protection and keep it on if the noise in the operator's position is greater than 80 dB. Noise that is louder than 85 dB on a long-term basis can cause severe hearing loss. Noise that is greater than 90 dB and adjacent to the operator on a long-term basis can cause permanent, total hearing loss.
- Remove all loose clothing, jewelry, or loose personal articles. Keep long hair tied up and covered. Loose items can get caught in moving parts and cause personal injury. Jewelry can ground a live electrical circuit and cause personal injury and machine damage.
- Do not consume alcohol or drugs before or during machine operation. Alertness or coordination can be affected. When you take prescription medications, speak with your doctor before you operate the machine.
- Only use the machine in daylight or good artificial light.
- Make sure that all guards and shields are installed. If it is necessary to remove a guard or shield for repair, install the guard or shield before you use the machine.
- Do not let anyone ride on the machine during transport.
- Keep bystanders a minimum of 10 ft (3 m) from the work zone. Use safety cones to identify the work zone perimeter.
- Stop the tractor engine and hydraulic system before you leave the machine unattended. Keep the tractor ignition key with you.
- Do not let anyone get on the tractor during machine operation. Only one person must operate the tractor and the machine.
- Always connect the machine to a tractor three-point hitch (3PH) before you operate it.





## 2.5 Equipment Safety Guidelines

Safety is one of the primary concerns in equipment design and development. However, every year there are accidents that can be prevented. Handle equipment carefully and fully understand the hazards. Everyone who works with the equipment must obey the following precautions to prevent hazards.

Obey the following precautions to avoid hazards. Make sure that anyone who works with you obeys them as well.

- Replace safety or instruction labels that are not readable or are missing. For locations and definitions, see *Safety Labels on page 13*.
- Do not change the equipment in any way. Unapproved changes can result in serious injury or death. In addition, unapproved changes can cause incorrect machine operation and decrease the service life of the machine. If anyone makes an unapproved change to the machine, the warranty is immediately void.
- Make sure that the machine is correctly stationed, adjusted, and in good condition.
- Keep the machine free of accumulated grease and debris to prevent fires and machine damage.
- Make sure that the logs and split-wood pile do not prevent the safe operation of the machine.
- Look for and keep away from overhead hazards (for example; branches, cables, and electrical wires).
- Do not exceed the limitations of the machine. If the machine does not operate normally or you feel unsafe, stop the machine!

## 2.6 Safe Condition

References are made to **safe condition** throughout this manual. Safe condition means that you put the machine in a state that makes it safe to service or maintain.

**Before you start any service or maintenance, do the following:**

### SAFE CONDITION

1. On the machine, fully retract the wedge.
2. Stop the tractor.  
For more information, see the tractor manufacturer's manual.
3. Disengage the tractor remote hydraulic system.
4. Operate the tractor hydraulic controls to release the pressure.
5. Apply the tractor parking brake.
6. Remove the tractor ignition key.  
Keep the ignition key with you to prevent someone from starting the tractor.
7. Use a block to support the machine and prevent movement.
8. Wait for the hydraulic fluid to cool.
9. Disconnect the two hydraulic hoses from the tractor.  
For instructions, see *Disconnect the Machine from a Tractor on page 26*.

## 2.7 Safety Training

An untrained operator can cause serious injury or death to themselves or other people who are nearby. Review the safety instructions with all users. To keep a record of safety training, see the *Training Record on page 10*.

- When someone does not understand the operation of a machine, they can create dangerous situations very quickly. Operators must understand the safety information in this manual and the safety labels that are on the machine.
- It is the owner's responsibility to provide instruction to everyone who is going to operate the machine. This machine is dangerous to anyone who does not know how to operate it safely.
- It is the owner's responsibility to make sure that each operator does the following before they operate the machine:
  - Reads and understands this manual.
  - Receives instruction in the safe and correct use of the machine.
  - Understands and knows how to set the machine to a **Safe Condition**.  
For instructions, see *Safe Condition*.

## 2.8 Training Record

Everyone who uses this machine must read and fully understand all safety and operation information in this manual. An untrained operator should not use this machine.

The following form can be used to record the completed training.

The design and manufacture of this product conforms to the applicable provisions in the following standards:

- ANSI/OPEI B71.7:2018 Powered Consumer Ram-Type Log Splitters - Safety Specifications
- ISO 4254-1:2013 Agricultural machinery – Safety
- ISO 3600:2022 Operator’s Manual – Machinery for Agriculture, Forestry & Lawn Equipment

### Training Record Form

Date	Owner’s signature	Operator or technician’s signature

## 2.9 Work Site



**The operator must be fully familiar with the work site before starting work. It is the operator's responsibility to prevent unsafe situations and make every effort to prevent accidents.**

W112

### 2.9.1 Select a Work Site

Select a safe work area and machine location:

- The ground should be firm and level.
- Make sure that there is sufficient space and clearance for the operator, the machine, and the split-wood pile.
- Remove all stones, branches, or hidden obstacles that can cause a hazard.
- Make sure that there are no overhead hazards such as branches, cables, or electrical wires.
- Select a location for the logs and split wood. Make sure that the logs and split-wood pile do not prevent the safe operation of the machine.
- Park the tractor and machine in a position where the prevailing winds blow the tractor engine exhaust away from the operator.

### 2.9.2 Create a Safe Work Area

Read and obey the instructions for safe operation of the machine.

Keep bystanders and workers safe from hazards. Obey the following important guidelines:

- Use safety cones to identify the work zone perimeter. The work zone perimeter must be a minimum of 10 ft (3 m) away from any hazard in the work zone. The area outside the work zone perimeter is the safe zone.
- Do not let people approach the work zone during machine operation. Everyone must signal and make eye contact with the operator before they approach the work zone.
- Keep all bystanders in the safe zone. Do not let bystanders in the work zone.
- Only the operator can let people enter the work zone. The operator must make sure that it is safe for a person to enter the work zone.
- When there are two or more workers, they must agree on a system of hand-signals to use for communication.
- The operator must make eye contact with coworkers and use the agreed system of hand signals. The operator must always be aware of their coworkers and know where they are.
- If there is fuel on the work site, store it far away from the machine and wood material.
- It is very important to be careful when you work near stacked logs. Stacked logs can move suddenly in unknown directions.
- Select a location to pile the logs and split wood. The split-wood pile should be on level ground. Make sure that the split-wood pile does not cause interference with safe operation of the machine
- Cut and remove all tree limbs and branches from the logs before they are put onto the machine.

A safe work area is divided into two zones:

#### 1. Safe Zone

The safe zone is the area outside the work zone perimeter (a minimum of 10 ft [3 m] away from any hazard). People who are not directly involved with the work can be in this area. There are minimal hazards in the safe zone.

#### 2. Work Zone

The work zone is the area between the hazard zone and the safe zone. People who help with the work and put on the necessary PPE can be in this zone. It is possible that there are hazards in the work zone.

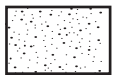

1. Safe zone



2. Work zone

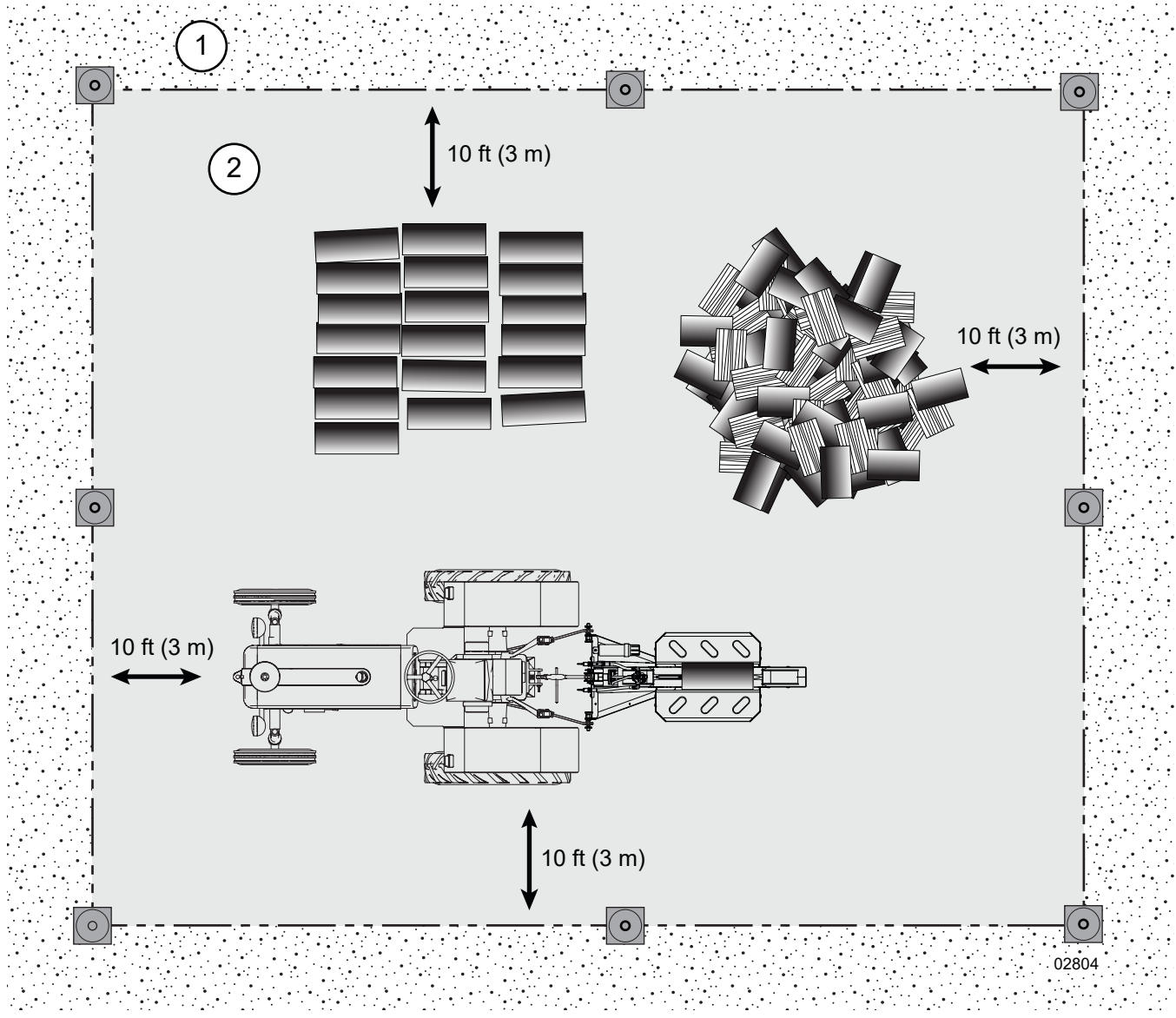

Figure 2—Example of a safe work area

## 3. Safety Labels

### WARNING!

Replace all safety labels that are missing, damaged, or illegible. If a component is replaced and it has a safety label on it, apply a safety label to the new component. If a person operates a machine with missing, damaged, or illegible safety labels it puts them at risk of serious injury or death.

W100

Learn what the safety labels mean and know the safety hazards. A safety label can be vertical or horizontal. Vertical safety labels have a top panel and a bottom panel. Horizontal safety labels have a left-side panel and a right-side panel. The top or left-side panel shows the safety alert (possible hazard), and the bottom or right-side panel shows the action message (how to prevent illness, injury, or death).

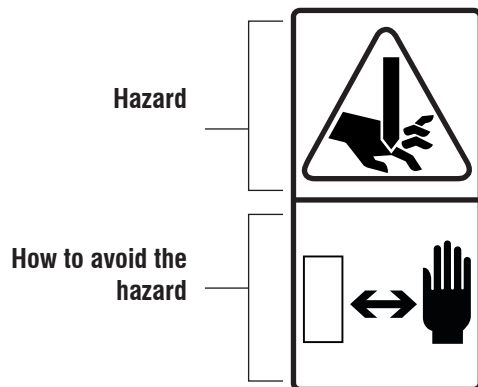

**Think SAFETY! Work SAFELY!**

### 3.1 Replace a Safety Label

- Always replace safety labels that are missing or have become illegible. Replacement safety labels are available from your local Wallenstein dealer or Wallenstein Equipment.
- Keep the safety labels clean and legible at all times.
- When a part that has a safety label on it is replaced, the correct safety label must be applied to the replacement part.

#### 3.1.1 Conditions

- The installation area must be clean and dry.
- The application surface must be clean and free of grease or oil.
- The ambient temperature must be above 50 °F (10 °C).

#### 3.1.2 Tool

Use a squeegee, plastic card, or similar tool to smooth the label.

#### 3.1.3 Procedure

1. Identify the label location.
2. Peel the label off the backing paper.
3. Hold the label above the location where you are going to apply it.  
Align the edges of the label with an edge of the machine.
4. Start at one edge and carefully press the center of the adhesive side of the label onto the machine.
5. Use an applicable tool to apply and smooth the label. Apply the label from one side to the other.
6. If there are small air pockets:
  - a. Use a pin to pierce the air pocket.
  - b. Use a piece of label backing paper to press the air pocket flat.

### 3.2 Safety Label Locations

The WX20H is shown, but the WX15H safety labels are the same.

Numbers correspond with the *Safety Label Definitions* on page 16.

Safety

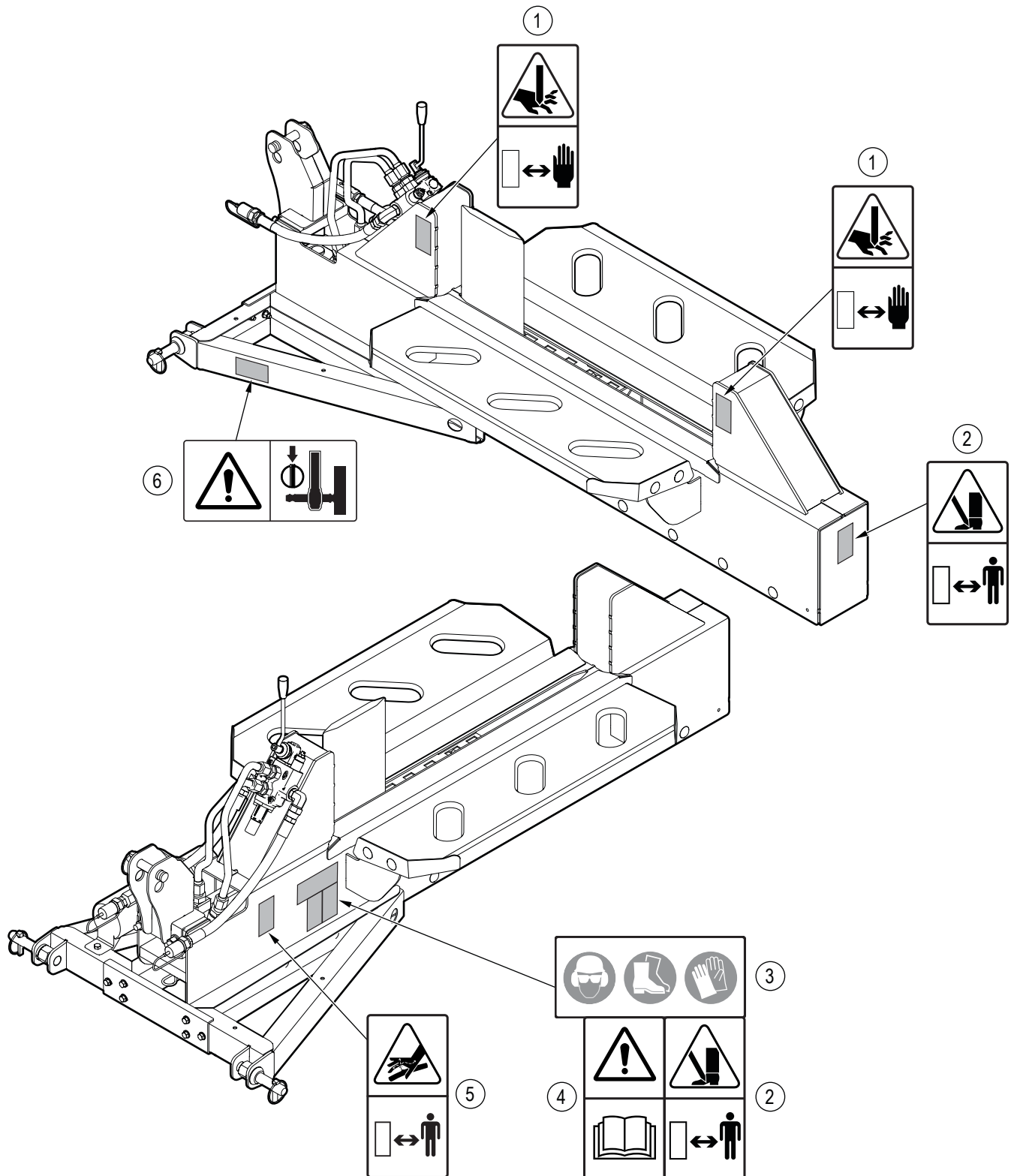

Figure 3—Safety label locations- left side (WX20H shown)

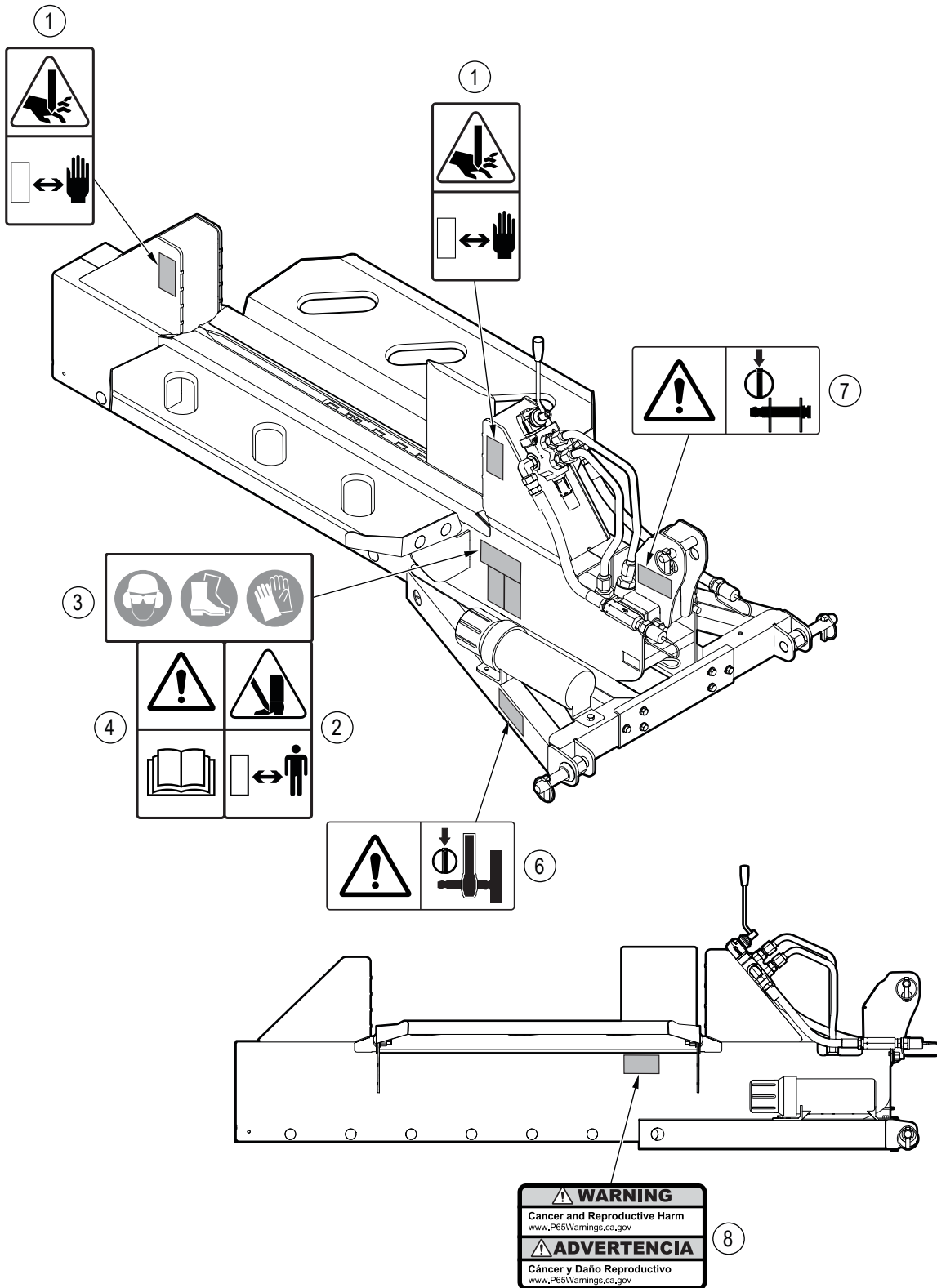

Figure 4—Safety label locations- right side (WX20H shown)

### 3.3 Safety Label Definitions

#### 1. Warning!

##### Crush, pinch, cut, or sever hazard

Hands or fingers can be crushed, pinched, cut, or severed in this area.

Keep your hands away from all moving parts. Wait for all moving parts to stop before you load or remove material. Put the machine in a safe condition before you remove a blockage.

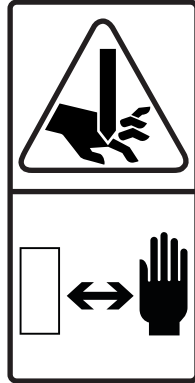

#### 2. Warning!

##### Impact and crush hazard

Feet and toes can be hit or crushed by material that falls from the machine.

Keep feet away from the area where the material falls. It is necessary for everyone who operates or works near the machine to put on the correct protective footwear.

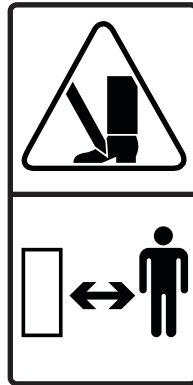

#### 3. Warning!

##### Put on the necessary PPE

For example:

- A hard hat.
- Heavy gloves.
- Hearing protection.
- Protective footwear with steel toes and slip resistant soles.
- Protective goggles or a face shield.



#### 4. Caution!

##### Read the Operator's Manual

There is important safety information and instructions in the Operator's Manual.

Read all the safety information and instructions in the Operator's Manual. Know what all the safety labels mean.

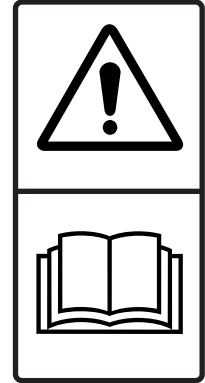

#### 5. Warning!

##### High-pressure injection hazard

Injection of pressurized hydraulic fluid can cause serious illness, injury, or death.

If you think there is a hydraulic fluid leak, move away from the area. Do not use your hands to inspect for hydraulic fluid leaks. Put on the correct hand and eye protection, and always use a piece of cardboard or wood to find a leak.



#### 6. Warning!

##### Impact and crush hazard

A tractor side link can disconnect from the machine if it is not safely connected. If a side link disconnects from the machine, the machine can fall and cause serious injury.

After you put a side link on the machine, put a linchpin through the machine connection pin. Make sure that each side link is connected correctly.

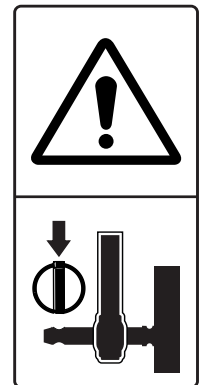



## 7. Warning!

### Impact and crush hazard

The machine can disconnect from the top link if the top link is not safely connected. If the machine disconnects from the top link, the machine can fall and cause serious injury.

Install a top-link pin through the top link and the machine top-link connection. Then install a linchpin through the top-link pin to keep the top-link pin in position. Make sure that the top link is connected correctly.

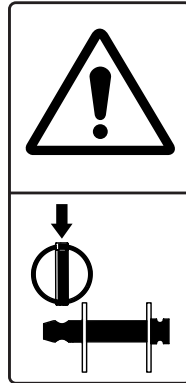

## 8. Warning!

### Risk of cancer and reproductive harm

The machine materials contain chemicals or machine operation can produce gases or dust that are identified by the state of California as causes of cancer, birth defects, or other reproductive harm.

This warning is a requirement of the state of California, USA to comply with Proposition 65: the Safe Drinking Water and Toxic Enforcement Act of 1986.



## 4. Familiarization

The Wallenstein WX15H and WX20H log splitters are designed to split logs into firewood.

When a log is put onto the split bed, the operator extends or retracts the double-sided wedge to split the log. The operator can then put another log onto the split bed and split the log from the other direction. The tractor remote hydraulic system provides power to the machine hydraulic system to move the double-sided wedge.

### 4.1 New Operator

#### WARNING!

Make sure that all operators understand how to put the machine in a safe condition before they start any service or maintenance work. For instructions, see *Safe Condition* on page 9.

It is the responsibility of the owner and the operator to read this manual, and to train all operators before they work with the machine. Obey all safety instructions.

Only a fully trained operator is approved to use the machine. A person who operates the machine without the correct training is a danger to themselves and others, and can cause property damage.

### 4.2 Training

Each operator must be trained in the correct operation procedures before they use the machine. Use the form on page 10 to keep a training record.

1. Teach the new operator the control locations, functions, and movement directions.
2. Put the machine in a large open area and let the new operator learn the control functions and machine responses.
3. After the new operator knows and is comfortable with the machine, they can start the work.

### 4.3 Operator Orientation

**IMPORTANT!** The directions that are referred to in this manual (left side, right side, front, and rear) are identified from the tractor seat or standing at the operator controls, facing the direction of forward machine travel.

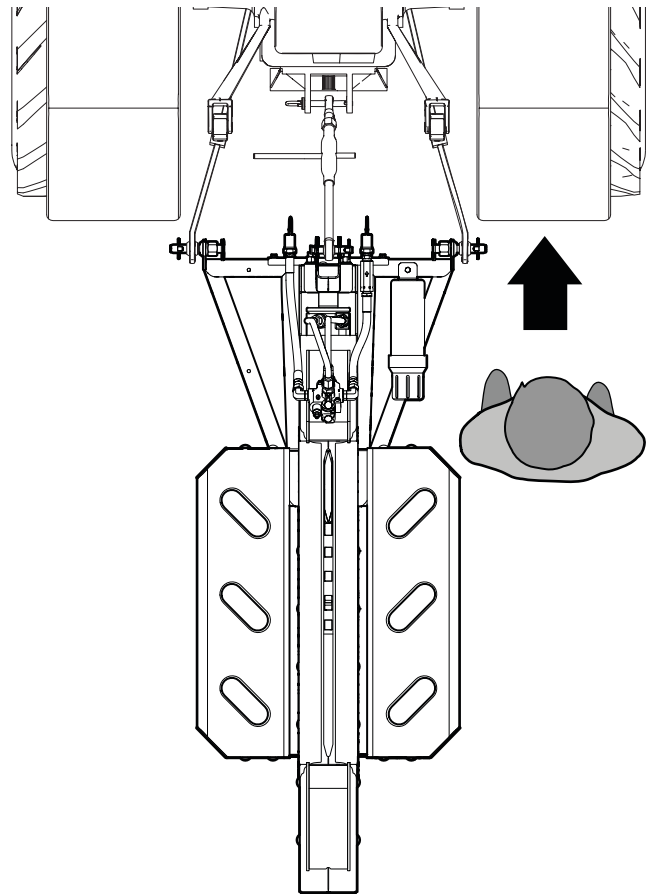
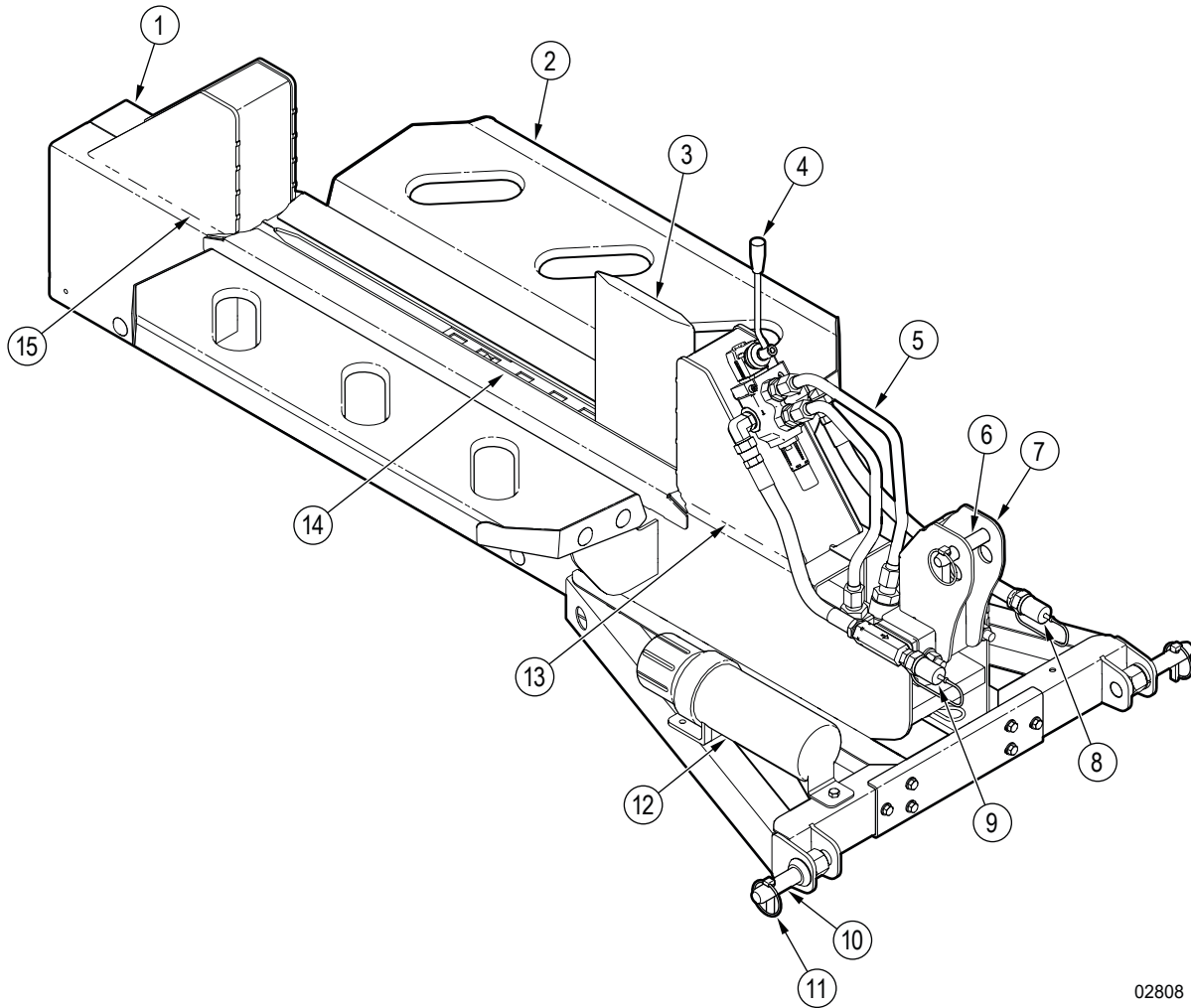

Figure 5—Operator orientation - direction of forward machine travel

## 4.4 Machine Components

Know the machine components before you operate, service, or maintain the machine.



02808

**Figure 6**—Machine components (WX20H shown)

- |                            |  |                           |
|----------------------------|--|---------------------------|
| 1. Frame                   | 6. Top-link hitch pin (removable)      | 11. Linchpin (1 of 3)     |
| 2. Log shelf (1 of 2)      | 7. Top link connection                 | 12. Document storage tube |
| 3. Double-sided wedge      | 8. Hydraulic hose - pressure (red cap) | 13. Front stop block      |
| 4. Splitter control        | 9. Hydraulic hose - return (black cap) | 14. Split bed             |
| 5. Hydraulic tube (1 of 2) | 10. Side-link hitch pin (1 of 2)       | 15. Rear stop block       |

## 5. Controls

### WARNING!

Do not operate the machine until you know the location of all the controls and how to use them correctly.

### 5.1 Splitter Control

The splitter control extends or retracts the double-sided wedge to split a log.

The splitter-control has the following functions:

- |                |   |
|----------------|---|
| <b>Extend</b>  | Push and hold the splitter control toward the rear of the machine to extend the wedge.<br>When you release the splitter control, it goes to the <b>Neutral</b> position and the wedge stops.  |
| <b>Neutral</b> | When the splitter control is in the center of the hydraulic valve, it is in the <b>Neutral</b> position. In this position, the wedge is stopped.<br>Logs can be put onto or removed from the machine when the splitter control is in the <b>Neutral</b> position.<br>You can move the splitter control to <b>Neutral</b> at any time to stop the wedge. |
| <b>Retract</b> | Pull and hold the splitter control toward the front of the machine to retract the wedge.<br>When you release the splitter control, it goes to the <b>Neutral</b> position and the wedge stops.  |

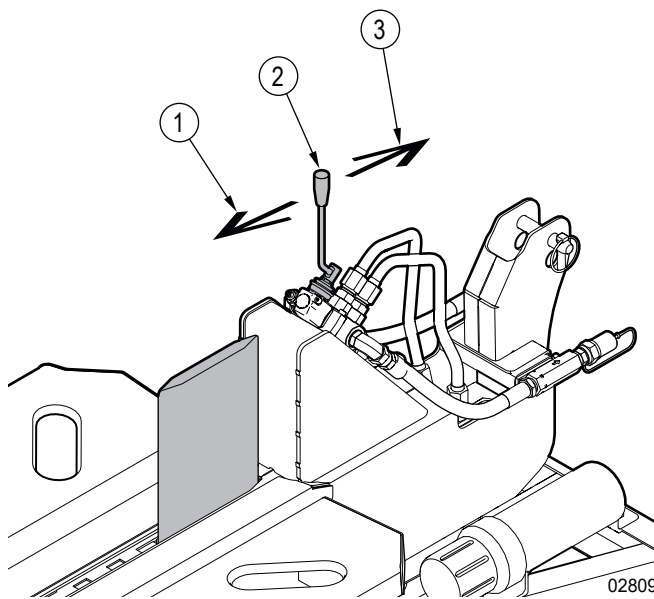

Figure 7 – Splitter control

1. Extend
2. Neutral
3. Retract

## 6. Operation

It is the operator's responsibility to know and obey all the operation and safety procedures.

### 6.1 Operation Safety

#### **WARNING!**

Put on the personal protective equipment (PPE) that is necessary to do the work safely.

This includes, but is not limited to hearing protection, heavy gloves, a face shield, and protective footwear.

W135

#### **WARNING!**

Do not let anyone get on the tractor during machine operation. The tractor can move unexpectedly and cause serious injury or death. Only one person must operate the tractor and the machine.

#### **WARNING!**

Only one person must handle the logs or split wood and operate the machine. A second person can be pinched, crushed, or have their hand or fingers severed by the wedge.

#### **WARNING!**

Always connect the machine to a tractor three-point hitch (3PH) before you operate it. If you try to operate the machine when it is not connected to a tractor, there are hazards that can cause serious injury or death.

#### **CAUTION!**

Do not split more than one log at one time. A log can be pushed out of the machine and cause personal injury.

#### **CAUTION!**

Do not split wood across the grain. Some types of wood can burst or splinter. Pieces of wood can become projectiles that are impact and cut hazards. Projectiles can cause personal injury.

#### **CAUTION!**

Wait for all movement to stop before you put a log on the machine or remove split wood or debris from the machine. When the wedge moves it can cut, sever, pinch, or crush your fingers or hands.

- Read and understand this manual before you start the machine. Review all safety information annually.
- Park the tractor in a clear location on dry, level ground. Do not operate the machine on a hillside or area that is cluttered, wet, muddy, or icy to prevent slips, trips, and falls.  
For more information, see *Work Site on page 11*.
- Keep the work area clean and free of debris.
- Only operate the tractor in a location that has good air flow. Engine exhaust gases contain carbon monoxide (an odorless gas) that can cause asphyxiation.
- Install all the guards and shields before you start the machine.
- Stop the tractor engine before you leave the machine unattended.
- Do not stand, sit, or climb on any part of the machine, especially while the tractor engine is on.
- Do not operate the machine alone. Always have a minimum of two trained people:
  - There should be one operator and one spotter present during machine operation. The operator and spotter must know all the machine safety, controls, and operation functions.
  - The operator must be in control of the machine and tractor at all times. The spotter must stay outside of the hazard zone during machine operation.
- Keep bystanders a minimum of 10 ft (3 m) from the tractor, machine, logs, and the split-wood pile. Use safety cones to identify the work zone perimeter.
- Do not step over or straddle the machine.
- Hold the sides of a log when you put it on the machine. Do not hold the cut ends of a log.

- Keep your hands, feet, clothing, and long hair away from the machine during operation.
- Know the movement and turn radius of the tractor and machine.
- Only move the tractor straight up or straight down a slope. Do not move across a slope. Lower the machine for stability.

## 6.2 Hydraulic System Operation Safety

### WARNING!

Pressurized hydraulic fluid can penetrate the skin or eyes and cause serious illness, injury, or death.

- **Make sure that all hydraulic connections are tight before you apply pressure to the hydraulic system.**
- **Put on the correct hand and eye protection and always use a piece of cardboard or wood to find a leak. Do not use your hands.**
- **If a high-pressure stream of hydraulic fluid penetrates your skin, get immediate medical attention from a doctor who is familiar with this type of injury. Serious infection or a toxic reaction can occur.**

W040

### CAUTION!

Keep exposed skin away from the hoses, fittings, and other hydraulic-system components. The hydraulic fluid becomes hot during operation, which causes the hoses, fittings, and other components to become hot.

**IMPORTANT!** Optimal hydraulic fluid temperatures are between 120° F and 140° F (50° C and 60° C). If the hydraulic fluid temperature is higher than 180° F (82° C), it can damage the seals and degrade the hydraulic fluid. High hydraulic fluid temperatures often indicate that there is a problem.

The hydraulic system is a closed-loop system that provides pressurized hydraulic fluid to the splitter control.

For more information, see *Hydraulic System Maintenance Safety* on page 32.

- Keep all the hydraulic system components clean and in good condition.

- Immediately replace a hydraulic hose or tube that shows signs of swelling, wear, leaks, or damage. A swollen, worn, damaged, or leaking hose or tube can burst and cause a hazardous, unsafe condition.

- High-pressure hydraulic fluid leaks:

- Do not use your hand to check for hydraulic fluid leaks. Injection of pressurized hydraulic fluid can cause serious illness, injury, or death. Put on heavy gloves and use a piece of cardboard or wood to check for leaks.



- Put on the correct eye protection before you inspect for a high-pressure hydraulic fluid leak.



- Get medical attention immediately if you are injured by a concentrated high-pressure stream of hydraulic fluid. Serious infection or a toxic reaction can occur after hydraulic fluid pierces the skin.
- Do not bend or hit high-pressure hydraulic hoses or tubes.
- Make sure that the hydraulic hoses do not rub on anything and the routing prevents damage.
- Do not adjust a pressure relief valve or other pressure-limiting device to a pressure that is more than the maximum pressure specification.

## 6.3 Pre-Start Checklist

Do the following before you start the machine the first time and each time after that.

Items to Complete	✓
Read and obey the <i>Operation Safety on page 21</i> and <i>Hydraulic System Operation Safety on page 22</i> .	
Examine the wedge and stop blocks. Make sure that they are in good condition and that the wedge moves freely.	
Use a safe method to check the hydraulic hoses, tubes, and fittings for leaks. If necessary, tighten the fittings or replace the components. Move a hose if it is pinched or rubs on something. For more information, see <i>Hydraulic Fitting Torque on page 37</i> .	
Remove anything that is entangled on the machine. For example, branches or vines.	
Install all the guards and shields. If a guard or shield is damaged, replace it.	
Make sure that all the fasteners are installed and torqued to the correct specifications. For more information, see <i>Bolt Torque on page 36</i> .	
Make sure that the operator and spotter put on the necessary PPE. The PPE must be in good condition.	
Make sure that the operator and spotter do not have loose-fitting clothing or jewelry on, and that long hair is tied up.	
Make sure that there are no bystanders inside the work zone and the spotter is not near a hazard. For zone definitions, see <i>Work Site on page 11</i> .	
Make sure that the tractor parking brake is applied correctly.	
Make sure that the machine is safely connected to the three-point hitch (3PH).	

## 6.4 Machine Break-In

Before and during the first eight hours of operation, do the following tasks.

### 6.4.1 Before First Use

1. Read and understand all safety information in this manual and the tractor manufacturer's manual.
2. Review the *Machine Components on page 19*.
3. Review the operation and function of the *Controls on page 20*.
4. Do the tasks in the *Pre-Start Checklist on page 23*.

### 6.4.2 After One to Five Hours of Operation

- Examine the wedge and stop blocks. Make sure that they are in good condition and that the wedge moves freely.
- Use a safe method to check the hydraulic hoses, tubes, and fittings for leaks. If necessary, tighten the fittings or replace damaged components. Move a hose if it is pinched or rubs on something. For more information, see *Hydraulic Fitting Torque on page 37*.
- Remove anything that is entangled on the machine. For example, branches or vines.
- Make sure that all the fasteners are installed and torqued to the correct specifications. For more information, see *Bolt Torque on page 36*.

### 6.4.3 After Eight Hours of Operation

- Complete the tasks that are listed under *After One to Five Hours of Operation*.
- Continue with the regular *Maintenance Schedule on page 33*.

## 6.5 Set Up the Machine



**WARNING!**

**Before you set up the machine, read and understand the *Hydraulic System Operation Safety on page 22*. The machine hydraulic hoses must be connected to the tractor's rear remote hydraulic system.**

1. Connect the machine to a tractor.  
See *Connect the Machine to a Tractor on page 24*.
2. Select a work site and set up a safe work area.  
For more information, see *Work Site on page 11*.
3. Stop the tractor engine, apply the parking brake, remove the key and keep it with you.

## 6.6 Connect the Machine to a Tractor

### WARNING!

Pressurized hydraulic fluid can penetrate the skin or eyes and cause serious illness, injury, or death.

- Make sure that all hydraulic connections are tight before you apply pressure to the hydraulic system.
- Put on the correct hand and eye protection and always use a piece of cardboard or wood to find a leak. Do not use your hands.
- If a high-pressure stream of hydraulic fluid penetrates your skin, get immediate medical attention from a doctor who is familiar with this type of injury. Serious infection or a toxic reaction can occur.

W040

### WARNING!

Keep people out of the area between the tractor and the machine during the connection procedure. If the driver goes too fast, cannot stop, or their foot accidentally moves off the clutch, people who are in this area can be seriously injured or killed.

W048

### CAUTION!

Before you connect the two hydraulic hoses between the tractor and the log splitter, read and understand all the hydraulic system information in the tractor manufacturer's manual. If you connect the hydraulic hoses incorrectly, there is a risk of personal injury or machine damage.

**IMPORTANT!** The machine and tractor hydraulic hose quick-connect fittings must be the same type. If necessary, change the machine quick-connect fittings to the same type as the tractor. A ball and socket quick-connect fitting and a poppet quick-connect fitting will connect; however, this connection does not provide hydraulic fluid flow that is dependable.



Category one (CAT I) three-point hitch pins and a top link are factory installed. CAT II hitch pins and a top link are included, but not installed.

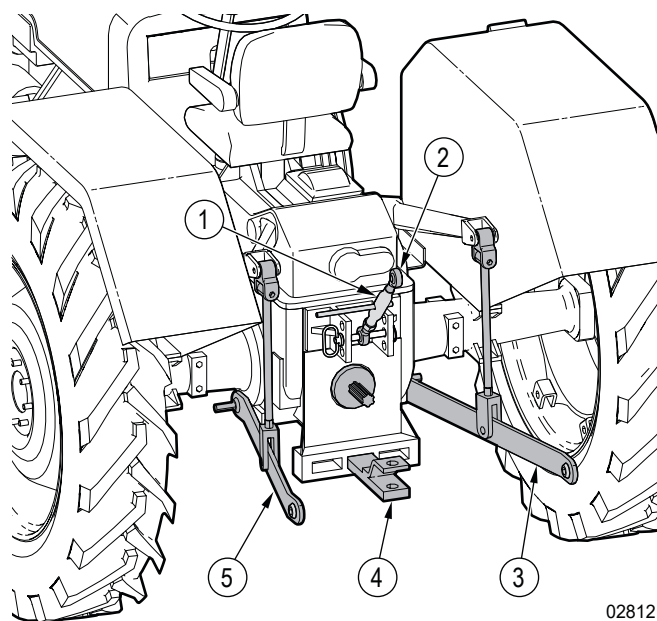

02812

**Figure 8**—Tractor three-point hitch components (example)

- |                         |                        |
|-------------------------|------------------------|
| 1. Top link turnbuckle  | 4. Drawbar             |
| 2. Top link             | 5. Left side side-link |
| 3. Right side side-link |                        |

Make sure that there is space and clearance to safely reverse the tractor to the machine.

1. Align the rear of the tractor with the machine
2. Slowly, reverse the tractor until the three-point hitch (3PH) is a minimum of 6 ft (2 m) away from the machine.
3. Fully lower the 3PH side links.  
If necessary, you can lift the side links by hand. You cannot lower the side links by hand because of the hydraulic pressure.
4. Stop the tractor engine, apply the parking brake, disengage the remote hydraulic connections, remove the key and keep it with you.  
Make sure that the hydraulic system is off.
5. Connect the machine to the 3PH side links:
  - a. On the 3PH, move the two side links to align with the machine hitch pins.
  - b. If it is necessary to prevent interference with the machine, fully retract or remove the tractor drawbar.
  - c. Carefully, reverse the tractor to the machine.  
Align the 3PH side links with the machine hitch pins.
  - d. Do step 4 again.
  - e. On the left side of the machine, remove the linchpin from the hitch pin.
  - f. Install the left side link on the hitch pin.
  - g. Install the linchpin through the hitch pin.
  - h. Do steps e. to g. on the right side of the machine.



**6. Connect the 3PH top link:**

- a. Put the free end of the 3PH top link between the two sides of the machine top-link connection.
- b. Put a hitch pin through the two sides of the machine top-link connection and the top link.
- c. Install a linchpin through the hitch pin.
- d. Adjust the top link until the machine is level.  
Keep the machine level during operation.

**7. Connect the two hydraulic hoses:**

- a. Use a clean cloth to remove dirt and debris from the hydraulic hose fittings.
- b. Connect the hoses to the correct tractor remote hydraulic connections (pressure and return).
- c. Route the hoses along the 3PH and use clips or plastic tie wraps to hold the hoses in position.  
Make sure that the hoses do not bind and are not kinked or pinched.

**8. Start the tractor and engage the remote hydraulic connections. The tractor must provide continuous hydraulic fluid flow to the machine. Keep the parking brake applied.**

**9. Push and hold the splitter control in the **Extend** position.**

**10. Do one of the following:**

- If the wedge extends, the hydraulic hoses are connected correctly. Continue with step 11.
- If the wedge does not extend or makes unusual or loud noise, the hydraulic hoses are not connected correctly. Do steps 2 to 4 of the procedure to *Disconnect the Machine from a Tractor* on page 26, and then do steps 7 to 10 of this procedure again.

**11. Slowly, lift and lower the machine through the full range of movement. Make sure that the machine, hydraulic hoses, and 3PH components move freely.**

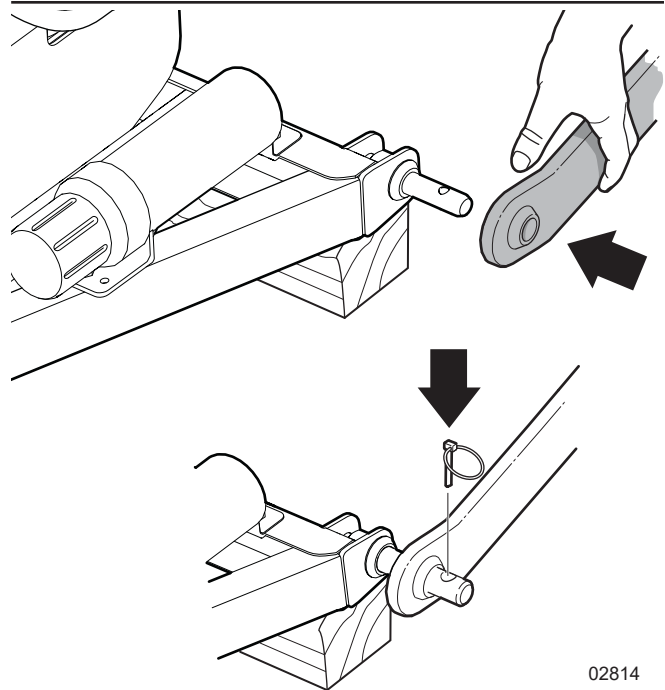

02814

**Figure 10**—Install a side link and linchpin

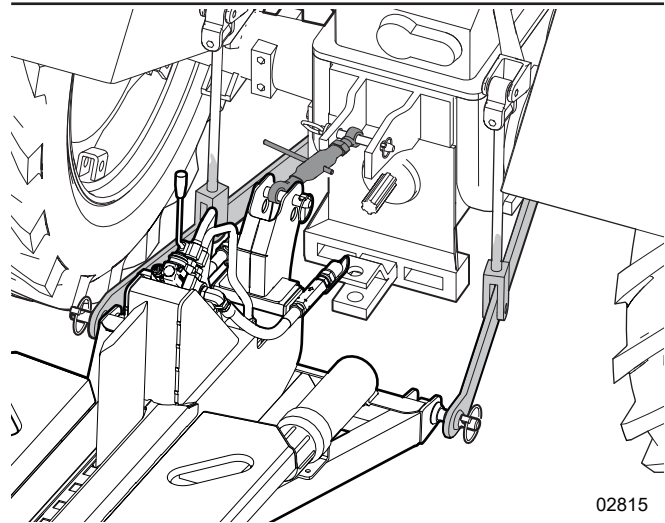

02815

**Figure 11**—Connected to a tractor

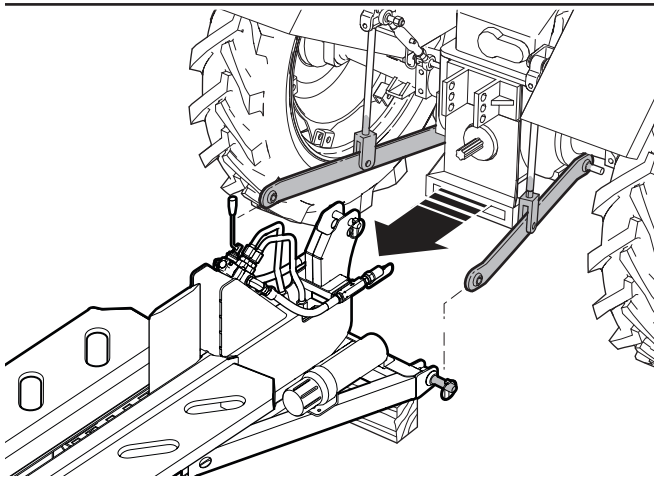

**Figure 9**—Align the tractor with the machine

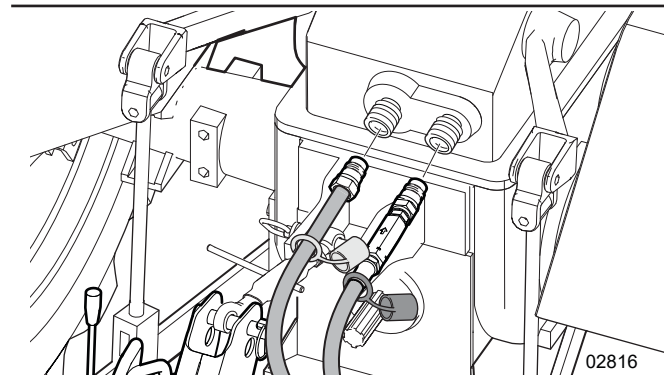

02816

**Figure 12**—Connect the hydraulic hoses

## 6.7 Disconnect the Machine from a Tractor

### CAUTION!

After you stop the tractor, operate each hydraulic control to release the hydraulic pressure. Make sure that you release the hydraulic pressure before you loosen a hydraulic hose connection. A thin, high pressure stream of hydraulic fluid can penetrate your skin and cause serious illness, injury, or death.



It is easier to disconnect or connect the machine to your tractor if you put the machine on blocks or a skid. The machine must be in a level position.

Always park the machine on level, dry ground that is free of debris and other foreign objects before you disconnect from the tractor.

1. Fully retract the wedge. Wait for all movement to stop.  
For more information, see *Splitter Control* on page 20.
2. Carefully, lower the three-point hitch (3PH) side links fully or until the machine touches the blocks or ground.
3. Stop the tractor engine, apply the parking brake, disengage the remote hydraulic connections, remove the key and keep it with you.  
Make sure that the hydraulic system is off.
4. Operate the tractor hydraulic controls to release the pressure.
5. Disconnect the two hydraulic hoses from the tractor.
6. Adjust the top link until the machine is fully on the ground.
7. Disconnect the 3PH top link:
  - a. Remove the linchpin and hitch pin from the top-link and machine top-link connection.
  - b. Put the top link in its storage position on the tractor.
  - c. Install the hitch pin through the machine top-link connection.
  - d. Install the linchpin in the hitch pin.
8. Disconnect the 3PH side links:
  - a. On the right side of the machine, remove the linchpin from the hitch pin.
  - b. Remove the left side link from the hitch pin.
  - c. Install the linchpin through the hitch pin.
  - d. Do steps a. to c. on the left side of the machine.
9. Move the two side links fully to the side (toward each tire).
10. Slowly, drive the tractor forward, away from the machine.

## 6.8 Start the Machine

### WARNING!

Before you start the machine, read and understand all the safety information in this manual and the tractor manufacturer's manual.

### WARNING!

Apply the tractor parking brake before you start the machine. If the parking brake is not applied, the tractor can move unexpectedly and cause serious injury or death.

1. Set up the machine.  
For instructions, see *Set Up the Machine* on page 23.
2. Do all tasks in the *Pre-Start Checklist* on page 23.
3. Move the splitter control to the **Neutral** position.  
For more information, see *Splitter Control* on page 20.
4. Start the tractor.  
For more information, see the tractor manufacturer's manual.
5. Set the tractor throttle to the correct speed for your tractor. The hydraulic fluid flow rate must be between **8 gpm (30 Lpm) and 20 gpm (76 Lpm)**.
6. Engage the tractor rear remote hydraulic connections and set them to continuous flow.

## 6.9 Stop the Machine

1. Fully retract the wedge. Wait for all movement to stop.  
For more information, see *Splitter Control* on page 20.
2. Move the splitter control to the **Neutral** position.  
For more information, see *Splitter Control* on page 20.
3. Stop the tractor.  
For instructions, see the tractor manufacturer's manual.
4. Apply the tractor parking brake.
5. Disengage the tractor rear remote hydraulic connections.
6. Operate the tractor hydraulic controls to release the pressure.

## 6.10 Emergency Stop

1. Stop the tractor.  
For instructions, see the tractor manufacturer's manual.
2. Apply the tractor parking brake.
3. Disengage the tractor rear remote hydraulic connections and make sure that the tractor hydraulic system is off.  
For instructions, see the tractor manufacturer's manual.
4. Remove the tractor ignition key and keep it with you.  
Do not let anyone start the tractor until the emergency situation is resolved.
5. If it is safe to do, operate the tractor and machine hydraulic controls to release the pressure.

## 6.11 Operate the Log Splitter

### **! WARNING!**

Put on the personal protective equipment (PPE) that is necessary to do the work safely.

This includes, but is not limited to, hearing protection, heavy gloves, a face shield, and protective footwear.

W135

### **! WARNING!**

Do not let anyone get on the tractor during machine operation. The tractor can move unexpectedly and cause serious injury or death. Only one person must operate the tractor and the machine.

### **! WARNING!**

Only one person must handle the logs or split wood and operate the machine. A second person can be pinched, crushed, or have their hand or fingers severed by the wedge.

### **! WARNING!**

Always connect the machine to a tractor three-point hitch (3PH) before you operate it. If you try to operate the machine when it is not connected to a tractor, there are hazards that can cause serious injury or death.

### **! CAUTION!**

Do not split more than one log at one time. A log can be pushed out of the machine and cause personal injury.

### **! CAUTION!**

Do not split wood across the grain. Some types of wood can burst or splinter. Pieces of wood can become projectiles that are impact and cut hazards. Projectiles can cause personal injury.

### **! CAUTION!**

Wait for all movement to stop before you put a log on the machine or remove split wood or debris from the machine. When the wedge moves it can cut, sever, pinch, or crush your fingers or hands.

Hold the sides of a log when you put it on the machine. Do not hold the cut ends of the log.

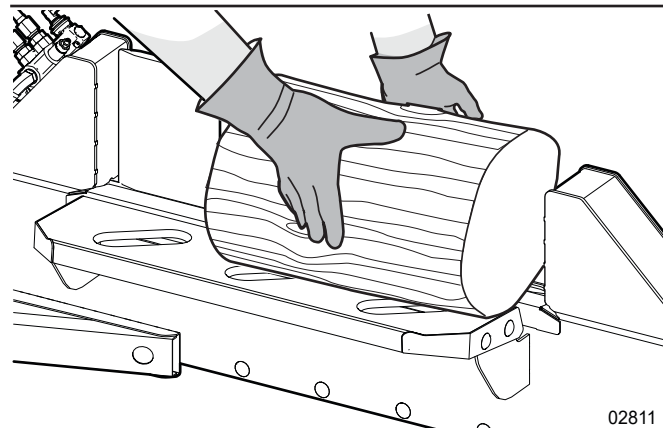

02811

Figure 13—Hold the sides of the log

### 6.11.1 Prepare the Material

- Remove all tree limbs and branches from the logs.
- Cut the logs across the grain. Make the ends of the log as flat as possible.
- Cut the logs to the correct length for the split bed.  
For more information, see *Machine Specifications* on page 35.

## 6.11.2 Split a Log

**IMPORTANT!** Release the splitter control immediately when the wedge gets to the fully extended or retracted position. If you hold the splitter control after the wedge is fully extended or retracted, the hydraulic fluid will become too hot.



When a log is cut unevenly, put the flattest edge of the log toward a stop block.

For more information, see *Figure 14*.

1. Set up the machine.  
For instructions, see *Set Up the Machine on page 23*.
2. Prepare the material.  
For instructions, see *Prepare the Material on page 27*.
3. Start the machine.  
For instructions, see *Start the Machine on page 26*.
4. Put a log on the split bed between the wedge and a stop block.  
Hold the sides of the log and put the flattest end of the log against the stop block.
5. Move away from the split bed.
6. Push and hold the splitter control in the **Extend** or **Retract** position (the direction that is applicable) to split the log.
7. Release the splitter control when the log splits or the wedge stops (gets to the fully extended or retracted position).
8. Remove the split wood from the machine. Put it on the split-wood pile.
9. Do steps 4 to 8 again, until the work is complete.

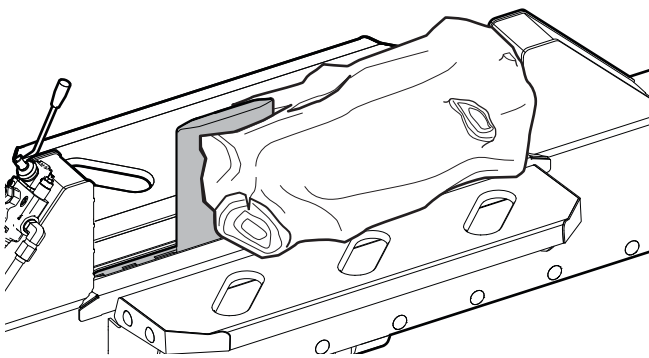

**Figure 14**—Split a log

## 6.11.3 Remove a Blockage

### **WARNING!**

Put the machine in a safe condition before you remove a blockage. Do not reach into the machine when it is not in a safe condition. When the machine is not in a safe condition, there are impact, crush, and sever hazards that can cause serious injury or death.

### **CAUTION!**

Put on thick work gloves before you remove a blockage. Thick work gloves give some protection from sharp objects and splinters.

If material collects on the machine, remove the blockage:

1. Set the machine to a safe condition.  
For instructions, see *Safe Condition on page 9*.
2. Remove all material from the split bed.
3. Remove all material from around the wedge.

## 7. Transport

**IMPORTANT!** Equipment that is transported on a public roadway must comply with the local laws that govern the safety and transport of machinery.

Before you take a WX15H or WX20H on a public roadway, make sure that the tractor has the necessary lights, reflectors, and markings, and that they are in good condition.

For specific requirements, contact your local transportation authority.

### 7.1 Transport Safety



Before you transport the machine, make sure that the machine is safely connected to the tractor, there is a retainer through each hitch connection, and the machine is off the ground.

**IMPORTANT!** If the hydraulic hoses are not connected to the tractor remote hydraulic connections, use a safe method to keep them on the machine and prevent movement.

- Do not let people ride on the machine.
- Move at a safe travel speed. Decrease your speed for rough terrain and around corners.
- Plan your route to stay away from heavy traffic.
- Make sure that all the guards and shields are installed.
- Remove all debris from the machine.
- After the machine is ready for transport, do a circle check to make sure that everything is safe.

### 7.2 Prepare the Machine for Transport

Select the applicable procedure to prepare the machine for transport.

#### 7.2.1 The Machine is Connected to a Tractor

1. Fully retract the wedge. Wait for all movement to stop.
2. Remove all logs, split wood, and debris from the machine.
3. Lower the machine for more stability.  
The machine must be a sufficient distance above the ground. Make sure that no objects on the ground will touch the machine during transport.
4. Do a circle check.  
Make sure that the slow-moving vehicle (SMV) sign is attached to the tractor and is in good condition.

#### 7.2.2 The Machine is not Connected to a Tractor

1. Remove all debris from the machine.
2. Connect the machine to a tractor.  
See *Connect the Machine to a Tractor* on page 24.
3. Lift the machine until it is a sufficient distance above the ground.  
Make sure that no objects on the ground will touch the machine during transport.
4. Do a circle check.  
Make sure that the slow-moving vehicle (SMV) sign is attached to the tractor and is in good condition.

## 8. Storage

At the end of the season or when the machine is not going to be used for long period of time, store the machine correctly to prevent damage.

### 8.1 Storage Safety



**Do not let children play on or around the stored machine. If children play on or around the machine it can result in serious injury or death.**

W105

- Store the machine in a dry, level location away from human activity.
- Store the machine indoors, where possible.
- If necessary, support the frame with planks.

### 8.2 Put the Machine in Storage

1. Move the machine to the storage location.
2. Disconnect the machine from the tractor.  
For instructions, see *Disconnect the Machine from a Tractor on page 26*.
3. Remove all entangled material.  
Check all moving parts for entangled material.
4. Clean the machine.  
For instructions, see *Clean the Machine on page 33*.
5. Paint areas where the paint has been removed. For example, scratches or damage.

If the machine must be stored outdoors, cover the machine with a waterproof tarp.

The machine should be stored indoors, if possible. An all-weather cover is available as an accessory. To purchase a cover, go to [WallensteinEquipment.com](http://WallensteinEquipment.com).

### 8.3 Remove the Machine from Storage

1. Do all the tasks in the *Pre-Start Checklist on page 23*.
2. Do the necessary maintenance.  
For maintenance information, see the *Maintenance Schedule on page 33*.

## 9. Service and Maintenance

Regular preventive maintenance can improve performance and prolong the life of the machine. Machine maintenance is your responsibility.

### 9.1 Service and Maintenance Safety

#### **WARNING!**

**Before you start service or maintenance:**

- **Set the machine to a safe condition.**
- **Wait for the machine to cool. Hot fluids and hydraulic system components can cause burns.**
- **Read and understand all the service and maintenance safety information.**

#### **WARNING!**

**Put on the personal protective equipment (PPE) that is necessary to do the work safely.**

**This includes, but is not limited to, hearing protection, heavy gloves, a face shield, and protective footwear.**

W135

#### **WARNING!**

**After service or maintenance, install all the guards and shields. Do not operate the machine with any guard or shield removed.**

- Use good shop practices:
  - Keep the work area clean and dry.
  - Ground electrical outlets and tools.
  - Have sufficient light for good visibility.
- Use tools that are in good condition and correct for the task. Make sure that you know how to use the tools before you use them.
- Only operate the tractor in a location that has good air flow. Engine exhaust gases contain carbon monoxide (an odorless gas) that can cause asphyxiation.
- Do not work under equipment unless it is safely supported with blocks.
- Do not do service or maintenance work alone. Always have a minimum of two people in case an emergency situation occurs.

- Keep a fire extinguisher and first aid kit available at all times.
- When service or maintenance is complete, do the following:
  - Install all the guards and shields.
  - Torque all the fasteners to the correct specifications.
  - Make sure that all the hydraulic fittings are connected correctly and in good condition.
- Do not use gasoline or diesel fuel to clean parts. Use the correct cleaning product.
- When replacement parts are necessary, use genuine factory replacement parts to restore your machine to the original specifications. The manufacturer cannot be responsible for injuries or damages caused by the use of unapproved parts and/or accessories.

**Put the machine in a safe condition before you start any service or maintenance:**

#### **SAFE CONDITION**

1. On the machine, fully retract the wedge.
2. Stop the tractor.  
For more information, see the tractor manufacturer's manual.
3. Disengage the tractor remote hydraulic system.
4. Operate the tractor hydraulic controls to release the pressure.
5. Apply the tractor parking brake.
6. Remove the tractor ignition key.  
Keep the ignition key with you to prevent someone from starting the tractor.
7. Use a block to support the machine and prevent movement.
8. Wait for the hydraulic fluid to cool.
9. Disconnect the two hydraulic hoses from the tractor.  
For instructions, see *Disconnect the Machine from a Tractor* on page 26.

## 9.2 Hydraulic System Maintenance Safety

### WARNING!

Pressurized hydraulic fluid can penetrate the skin or eyes and cause serious illness, injury, or death.

- Make sure that all hydraulic connections are tight before you apply pressure to the hydraulic system.
- Put on the correct hand and eye protection and always use a piece of cardboard or wood to find a leak. Do not use your hands.
- If a high-pressure stream of hydraulic fluid penetrates your skin, get immediate medical attention from a doctor who is familiar with this type of injury. Serious infection or a toxic reaction can occur.

W040

### CAUTION!

Keep exposed skin away from the hoses, fittings, and other hydraulic-system components. The hydraulic fluid becomes hot during operation, which causes the hoses, fittings, and other components to become hot. Wait for the hydraulic fluid and hydraulic-system components to cool before you start maintenance, service, or troubleshooting.

**IMPORTANT!** Optimal hydraulic fluid temperatures are between 120° F and 140° F (50° C and 60° C). If the hydraulic fluid temperature is higher than 180° F (82° C), it can damage the seals and degrade the hydraulic fluid. High hydraulic fluid temperatures often indicate that there is a problem.

The hydraulic system provides pressurized hydraulic fluid to the splitter control through the hydraulic cylinder. The hydraulic system makes the wedge extend or retract.

For more information, see *Hydraulic System Operation Safety* on page 22.

- Make sure that all hydraulic system components are kept clean and in good condition.
- Release the pressure on the hydraulic system before you work with it. The hydraulic system operates under very high pressure.

- Before you apply pressure to the hydraulic system, make sure that all the connections are tight, and the hoses, tubes, and fittings are not damaged.
- Immediately replace a hydraulic hose that shows signs of swelling, wear, leaks, or damage. A swollen, worn, damaged, or leaking hose can break and cause a dangerous condition.  
For more information, see *Hydraulic Hose Specifications* on page 35.

- High-pressure hydraulic fluid leaks:

- Do not use your hand to check for hydraulic fluid leaks. Injection of pressurized hydraulic fluid can cause serious illness, injury, or death. Put on heavy gloves and use a piece of cardboard or wood to check for leaks.



- Put on the correct eye protection before you do an inspection for a high-pressure hydraulic leak.

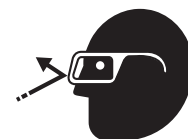

- Get medical attention immediately if you are injured by a concentrated high-pressure stream of hydraulic fluid. Serious infection or a toxic reaction can occur after hydraulic fluid pierces the skin.
- Do not make any temporary repairs to the hydraulic hoses, tubes, or fittings. Do not use tape, clamps, or cements to try a repair. This can cause sudden failure and create a dangerous condition.
- Do not bend or strike high-pressure hoses or tubes.
- Do not install a high-pressure hose or tube that is bent or damaged.
- Make sure that the hydraulic hoses do not rub on anything and the routing prevents damage.
- Do not adjust a pressure relief valve or other pressure-limiting device to a pressure that is more than the maximum pressure specification.



## 9.3 Maintenance Schedule

Do maintenance tasks at the specified time or hour interval, whichever comes first.

Task	8 hours or daily	100 hours or annually	Reference
Torque all the fasteners to the correct specifications.	●		See page 36.
Torque the hydraulic fittings to the correct specifications.	●		See page 37.
Remove all debris and entangled material.	●		N/A.
Clean the machine.		●	See page 33.

## 9.4 Clean the Machine

**IMPORTANT!** Do not use gasoline, diesel fuel, or thinners to clean the machine. Harsh chemicals can damage the machine finish.

**IMPORTANT!** Do not direct the spray from a pressure washer onto the product identification plate.

**A pressure washer can damage the label.**

1. Use a hose or pressure washer and mild detergent to remove dust, dirt, and debris.
2. Use a clean, soft cloth, that is dampened with water to remove dirt from the product identification plate.

## 9.5 End of Service Life

When the machine is at the end of its service life (EoSL), take it to an approved location for recycling.

# 10. Troubleshooting



## WARNING!

**Before troubleshooting, read and understand the *Service and Maintenance Safety on page 31*. Set the machine to a safe condition.**

If you find a problem that is difficult to solve, even after reading this information, please contact your local Wallenstein dealer or Wallenstein Equipment. When you contact someone, please have the serial number of your product available. To find the serial number on your machine, see *Serial Number Location on page 5*.

The following table lists some of the problems that can occur and gives possible causes and solutions.

Problem	Possible cause	Solution
<b>The wedge moves slowly or does not move (there is an unusual or loud noise).</b>	There is no hydraulic fluid pressure.	The tractor hydraulic fluid filter is blocked. Change the hydraulic filter.
		The tractor hydraulic fluid level is low. Add hydraulic fluid to the system.
		The tractor hydraulic system relief pressure is set too low. Contact an approved technician to verify and adjust the pressure relief setting.
	The hydraulic hoses are connected incorrectly.	Disconnect the two hydraulic hoses, and then connect them to the opposite tractor connections. See <i>Disconnect the Machine from a Tractor on page 26</i> . Alternative method: change the tractor remote hydraulic fluid flow to the opposite direction.
	The wedge is blocked.	Set the machine to a safe condition and remove the blockage. See <i>Remove a Blockage on page 28</i> .
<b>The wedge does not stop when the splitter control is released.</b>	The tractor engine speed is low.	Increase the engine speed (throttle).
	The splitter control is damaged.	Repair or replace the splitter control. Contact an approved technician.
<b>The wedge stops when it touches the log.</b>	The tractor hydraulic fluid is contaminated.	Change the hydraulic fluid and filter.
	The tractor hydraulic pump does not operate correctly.	Repair or replace the hydraulic pump. Contact an approved technician.
	The hydraulic-cylinder seals are worn or damaged.	Replace the hydraulic-cylinder seals. Contact an approved technician.
<b>A hydraulic hose, tube, or fitting has a leak.</b>	The tractor hydraulic system pressure relief is set too low.	Contact an approved technician to verify and adjust the pressure relief setting.
	The hydraulic hose or tube is worn or damaged, or a fitting is loose.	Repair or replace the hydraulic hose or tube, or tighten the fitting. Contact an approved technician.
<b>The hydraulic cylinder has a leak.</b>	The hydraulic cylinder seals are worn or damaged.	Replace the hydraulic-cylinder seals. Contact an approved technician.

# 11. Specifications<sup>1</sup>

For available accessories, go to [WallensteinEquipment.com](http://WallensteinEquipment.com).

## 11.1 Machine Specifications

Parameter	WX15H	WX20H
Compatibility	Tractor	
Split force	15 ton	20 ton
Cylinder stroke	19" (48 cm)	24" (61 cm)
Cylinder diameter	3.5" (9 cm)	4" (10 cm)
Split bed orientation	Horizontal	
Wedge type	Double-sided	
Wedge height	7.4" (19 cm)	9.4" (24 cm)
Three-point hitch	Cat I or Cat II	
Average cycle time	3.6 seconds	6.6 seconds
Total cycle time <sup>2</sup> (11 gpm hydraulic fluid flow)	7.15 seconds	13.2 seconds
Total weight	280 lb (127 kg)	360 lb (163 kg)
Dimensions (L x W x H)	61.2" x 32.2" x 26.7" (155.5 cm x 81.8 cm x 67.8 cm)	70.1" x 32.7" x 28.4" (178.1 cm x 83.1 cm x 72.1 cm)

## 11.2 Hydraulic System Specifications

The following table provides information about the machine's hydraulic system. When you repair or replace parts, make sure that the new components have the correct specifications.

### 11.2.1 Hydraulic Hose Specifications

Parameter	Type	Operation Pressure
High-pressure tube	SAE J524 hardline tube 5/8" (15.9 mm) inside diameter	3,000 psi (maximum 3,200 psi)
High-pressure hose	SAE 100R17 braided 1/2" (12.5 mm) inside diameter (SAE -8) 3/8" (10 mm) inside diameter (SAE -6)	3,000 psi (maximum 3,200 psi)

### 11.2.2 Hydraulic Fluid Flow Rate

Hydraulic fluid flow rate must be between **8 gpm (30 Lpm)** and **20 gpm (76 Lpm)**.

### 11.2.3 Hydraulic System Relief Pressure

Set the hydraulic system relief pressure at **3200 psi (221 bar)**.

<sup>1</sup> Specifications are subject to change without notice.

<sup>2</sup> Cycle time depends on the tractor remote hydraulic fluid flow rate.

## 11.3 Bolt Torque

**IMPORTANT!** If you replace hardware, use fasteners of the same grade.

**IMPORTANT!** The torque specifications in these tables are for non-greased or non-oiled threads. Do not grease or oil fastener threads unless otherwise indicated. When using a thread lock, increase the specified torque 5%.



Bolt grades are identified by the marks on top of the bolt head.

These bolt torque specification tables provide the correct torque settings for common bolts and capscrews. Tighten all bolts to the torque that is specified in the table, unless otherwise indicated. Check the bolt tightness periodically.

### Imperial Bolt Torque Specifications

Bolt Diameter	Torque					
	SAE Gr. 2		SAE Gr. 5		SAE Gr. 8	
	lbf•ft	N•m	lbf•ft	N•m	lbf•ft	N•m
<b>1/4 inch</b>	6	8	9	12	12	17
<b>5/16 inch</b>	10	13	19	25	27	36
<b>3/8 inch</b>	20	27	33	45	45	63
<b>7/16 inch</b>	30	41	53	72	75	100
<b>1/2 inch</b>	45	61	80	110	115	155
<b>9/16 inch</b>	60	95	115	155	165	220
<b>5/8 inch</b>	95	128	160	215	220	305
<b>3/4 inch</b>	165	225	290	390	400	540
<b>7/8 inch</b>	170	230	420	570	650	880



SAE Gr. 2



SAE Gr. 5



SAE Gr. 8

### Metric Bolt Torque Specifications

Bolt Diameter	Torque			
	Gr. 8.8		Gr. 10.9	
	lbf•ft	N•m	lbf•ft	N•m
<b>M3</b>	0.4	0.5	1.3	1.8
<b>M4</b>	2.2	3	3.3	4.5
<b>M6</b>	7	10	11	15
<b>M8</b>	18	25	26	35
<b>M10</b>	37	50	52	70
<b>M12</b>	66	90	92	125
<b>M14</b>	83	112	116	158
<b>M16</b>	166	225	229	310
<b>M20</b>	321	435	450	610
<b>M30</b>	1,103	1,495	1,550	2,100



8.8



10.9

## 11.4 Hydraulic Fitting Torque

Tighten flare-type tube fittings:

1. Check the flare and flare seat for defects that might cause leaks.
2. Align the tube with the fitting before tightening.
3. Hand-tighten the swivel nut until it is snug.
4. To prevent the tube from twisting, use two wrenches. Place one wrench on the connector body and tighten the swivel nut with the second wrench. Torque the fitting to the correct specification.

If a torque wrench is not available, use the flats from finger tight (FFFT) method.

Hydraulic Fitting Torque Specifications					
Tube size OD	Hex size across flats	Torque		Flats from finger tight	
		lbf•ft	N•m	Flats	Turns
3/16	7/16	6	8	2	1/6
1/4	9/16	11–12	15–17	2	1/6
5/16	5/8	14–16	19–22	2	1/6
3/8	11/16	20–22	27–30	1-1/4	1/6
1/2	7/8	44–48	59–65	1	1/6
5/8	1	50–58	68–79	1	1/6
3/4	1-1/4	79–88	107–119	1	1/8
1	1-5/8	117–125	158–170	1	1/8

Specifications are for non-lubricated connections.

## 12. Warranty



### LIMITED WARRANTY

Wallenstein products are warranted to be free of defects in materials and workmanship under normal use and service, for a period of

**Five Years for Consumer Use**

**Two Years for Commercial/Rental Use**

from the date of purchase, when operated and maintained in accordance with the operating and maintenance instructions supplied with the unit. Warranty is limited to the repair of the product and/or replacement of parts.

This warranty is extended only to the original purchaser and is not transferable.

Repairs must be done by an authorized dealer. Products will be returned to the dealer at the customer's expense. Include the original purchase receipt with any claim.

**This warranty does not cover the following:**

- 1) Normal maintenance or adjustments
- 2) Normal replacement of wearable and service parts
- 3) Consequential damage, indirect damage, or loss of profits
- 4) Damages resulting from:
  - Misuse, negligence, accident, theft or fire
  - Use of improper or insufficient fuel, fluids or lubricants
  - Use of parts or aftermarket accessories other than genuine Wallenstein parts
  - Modifications, alteration, tampering or improper repair performed by parties other than an authorized dealer
  - Any device or accessories installed by parties other than an authorized dealer
- 5) Engines. Engines are covered by the manufacturer of the engine for the warranty period they specify. For the details of your engine warranty, see your engine owner's manual. Information about engine warranty and service is also available in the FAQ section at [www.wallensteinequipment.com](http://www.wallensteinequipment.com)

# 13. Index

	<b>A</b>			<b>M</b>
Accessories .....		3	Machine .....	
	<b>B</b>		Break in .....	23
Blockage, remove .....		28	Clean .....	33
Bolt torque .....		36	Components .....	19
Break-in .....		23	Emergency stop .....	27
	<b>C</b>		Operate .....	21
Checklist .....			Prepare for transport .....	29
Dealer inspection .....		4	Setup .....	23
Pre-start .....		23	Specifications .....	35
Clean the machine .....		33	Start .....	26
Components, machine .....		19	Maintenance· See Service and Maintenance	
Connect to tractor .....		24	Maintenance schedule .....	33
Controls .....		20	Material, prepare .....	27
Splitter .....		20		
	<b>D</b>			<b>N</b>
Delivery inspection .....			New operator .....	18
Dealer inspection checklist .....		4	Training .....	18
Delivery inspection report .....		4		
Dimensions .....		35		<b>O</b>
Disconnect from tractor .....		26	Operation .....	21
	<b>E</b>		Break-in .....	23
Emergency stop .....		27	Emergency stop .....	27
End of service life .....		33	Hydraulic system safety .....	22
Equipment guidelines, safety .....		9	Operate the log splitter .....	27
	<b>F</b>		Operation safety .....	21
Familiarization .....		18	Pre-start checklist .....	23
Form, training record .....		10	Set up the machine .....	23
	<b>H</b>		Start the machine .....	26
Hydraulic system .....			Stop the machine .....	26
Fitting torque .....		37	Emergency stop .....	27
Maintenance safety .....		32	Operator .....	
Operation safety .....		22	New .....	18
Specifications .....		35	Orientation .....	18
	<b>I</b>		Training .....	18
Inspection .....				<b>P</b>
Dealer checklist .....		4	Prepare the material .....	27
Delivery report .....		4	Pre-start checklist .....	23
Introduction .....		3	Product identification plate location .....	5
	<b>L</b>			<b>R</b>
Labels .....			Register your product .....	4
Information labels .....		6	Remove a blockage .....	28
Maintenance labels .....		6	Report, delivery inspection .....	4
Mandatory action labels .....		6		
Product labels .....		6		<b>S</b>
Replace a safety label .....		13	Safe condition .....	9
Safety labels .....		6	Safety .....	7
Definitions .....		16	Alert symbol .....	7
Locations .....		14	Equipment guidelines .....	9
Types .....		6	Hydraulic system .....	
			Maintenance .....	32
			Operation .....	22
			Operation .....	21
			Rules .....	8
			Safe condition .....	9
			Service and maintenance .....	31
			Signal words .....	7
			Storage .....	30

Training.....	9
Transport.....	29
Work site.....	11
Safety labels.....	13
Definitions.....	16
Locations.....	14
Replace.....	13
Serial number location.....	5
Service and maintenance.....	31
Clean the machine.....	33
Maintenance schedule.....	33
Safety.....	31
Service life, end of.....	33
Set up the machine.....	23
Specifications.....	35
Hydraulic system.....	35
Machine.....	35
Torque	
Bolt.....	36
Hydraulic fittings.....	37
Split a log.....	28
Splitter control.....	20
Start the machine.....	26
Stop the machine.....	26
Emergency stop.....	27
Storage.....	30
Put in storage.....	30
Remove from storage.....	30
Safety.....	30

**T**

Torque specifications	
Bolt torque.....	36
Hydraulic fitting torque.....	37
Total weight.....	35
Tractor	
Connect machine.....	24
Disconnect machine.....	26
Training	
New operator.....	18
Record.....	10
Safety.....	9
Transport.....	29
Prepare for.....	29
Safety.....	29
Troubleshooting.....	34
Types of labels.....	6

**W**

Warranty.....	38
Start the warranty.....	4
Website.....	3
Work site.....	11
Create a safe work area.....	11
Example of a safe work area.....	12
Safe zone.....	11
Select a work site.....	11
Work zone.....	11

**Z**

Zones	
Safe zone.....	11
Work zone.....	11











**MAKING WORK FEEL MORE LIKE PLAY™**

[WallensteinEquipment.com](http://WallensteinEquipment.com)

