

OPERATOR'S MANUAL

Serial numbers 1100643 and up

WXR545PL

Log Splitter

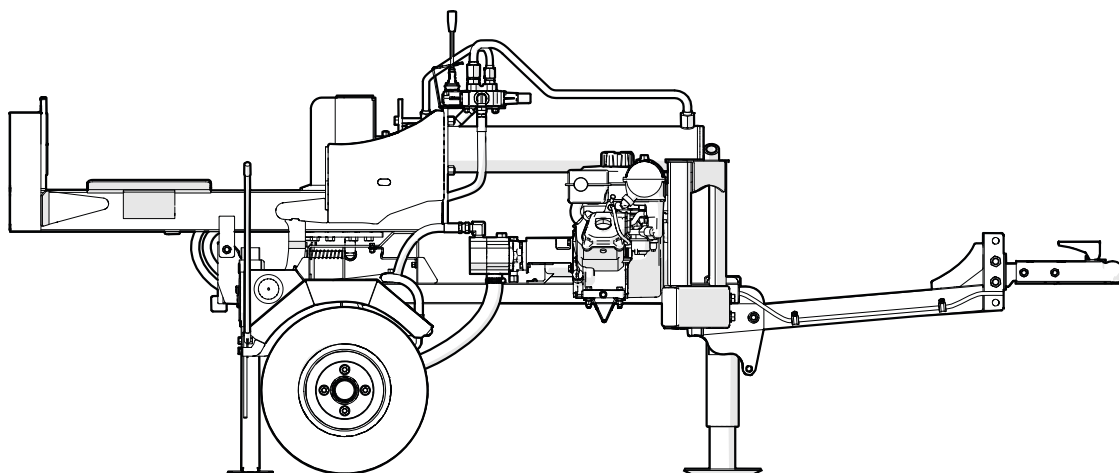

Rev Jun-2023

Part Number: Z97127_En

WALLENSTEIN

Table of Contents

1. Introduction	3	7. Transport.....	31
1.1 Delivery Inspection Report	4	7.1 Transport Safety	31
1.2 Serial Number Location.....	5	7.2 Prepare for Transport.....	31
1.3 Decal Information	6	7.3 Connect to a Tow Vehicle	32
2. Safety	7	8. Storage.....	33
2.1 Safety Alert Symbol	7	8.1 Place the Machine in Storage.....	33
2.2 Signal Words.....	7	8.2 Remove the Machine from Storage	33
2.3 Why Safety is Important.....	8	9. Service and Maintenance.....	34
2.4 Safety Rules	8	9.1 Maintenance Safety	34
2.5 Equipment Safety Guidelines.....	9	9.2 Fluids and Lubricants.....	34
2.6 Safety Training.....	9	9.3 Maintenance Schedule.....	36
2.7 Refueling Safety.....	9	9.4 Grease Points	37
2.8 Tire Safety	9	9.5 Change the Hydraulic Fluid.....	38
2.9 Hydraulic Safety	10	9.6 Change the Hydraulic Fluid Filter	38
2.10 Engine Safety	10	9.7 Engine Air Filter.....	39
2.11 Be Prepared.....	11	10. Troubleshooting.....	40
2.12 Sign-Off Form.....	12	11. Specifications	41
3. Safety Signs.....	13	11.1 Machine Specifications	41
3.1 Safety Sign Locations	13	11.2 Bolt Torque.....	42
3.2 Safety Sign Explanations.....	14	11.3 Hydraulic Fitting Torque	43
4. Familiarization	15	11.4 Lug Nut Torque.....	43
4.1 To the New Operator.....	15	12. Warranty.....	44
4.2 Machine Components.....	16	13. Index.....	45
5. Controls	17		
5.1 Engine Controls	17		
5.2 Splitter Control.....	19		
5.3 Stroke Limiter Accessory.....	20		
5.4 Splitter Bed Spring Latch.....	21		
6. Operating Instructions	22		
6.1 Operating Safety	22		
6.2 Before Starting the Engine.....	22		
6.3 Pre-operation Checklist.....	23		
6.4 Machine Break-In.....	23		
6.5 Check the Engine Oil Level	24		
6.6 Check the Hydraulic Fluid Level.....	25		
6.7 Check the Fuel Level	25		
6.8 Machine Setup.....	26		
6.9 Start the Machine.....	26		
6.10 Stop the Machine.....	27		
6.11 Emergency Stop	27		
6.12 Log Placement.....	27		
6.13 Split Wood.....	28		

1. Introduction

WARNING!

Do not attempt to start or operate the machine before you read this manual thoroughly. Make sure that you understand how to operate the machine correctly and safely before you use it.

Keep this manual with the machine at all times.

W034

Congratulations on choosing a **Wallenstein WXR545PL Log Splitter!**

This high-quality machine is designed and manufactured to meet the needs of an efficient wood splitting operation.

The 22-ton WXR Series log splitters feature Wallenstein *2x2-Speed Firebolt* Technology. Splitting cycle time is reduced using a high-volume, two-stage hydraulic pump and a regenerative control valve. The splitter control has two positions that provide either high speed or high power.

This manual covers the WXR545PL log splitter. The WXR545PL features horizontal, 20° angled, and vertical splitting.

Information that is specific to a model is noted. Otherwise, the information in this manual applies to all of the listed models.

Units of measurement in Wallenstein Equipment technical manuals are written as:
US Customary (SI metric).

Keep this manual handy for frequent reference and to pass on to new operators or owners. Call your Wallenstein dealer or distributor if you need assistance, information or additional copies of the manuals.

Wallenstein Equipment Inc. • © 2023. All rights reserved.

No part of this work may be copied, reproduced, replaced, distributed, published, displayed, modified, or transferred in any form or by any means except with the prior permission of Wallenstein Equipment Inc.

Review all safety, operation and maintenance information contained in this manual.

 WARNING
Cancer and Reproductive Harm www.P65Warnings.ca.gov
 ADVERTENCIA
Cáncer y Daño Reproductivo www.P65Warnings.ca.gov



1.1 Delivery Inspection Report

Wallenstein WXR545PL Log Splitter

To register your product and start the warranty, go to WallensteinEquipment.com.

This form must be completed by the dealer at the time of delivery, and then signed by the dealer and customer.

I received the product manuals and was thoroughly instructed about the care, adjustments, safe operation, and applicable warranty policy.

I thoroughly instructed the customer about the equipment care, adjustments, safe operation, and applicable warranty policy, and reviewed the manuals with them.

_____	Customer
_____	Address
_____	City, State/Province, ZIP/Postal Code
(_____)	Phone Number
_____	Contact Name
_____	Model
_____	Serial Number
_____	Delivery date

_____	Dealer
_____	Address
_____	City, State/Province, ZIP/Postal Code
(_____)	Phone Number

Dealer Inspection Checklist

- _____ Horizontal and vertical pivot moves freely.
- _____ All support stands move freely.
- _____ Machine controls function correctly.
- _____ All fasteners are tightened to the correct torque.
- _____ All grease points are lubricated.
- _____ Purchased accessories are included, if applicable.
- _____ Operator's Manual is in the storage tube.
- _____ Hydraulic system and cylinders function correctly.
- _____ Hydraulic controls move freely.
- _____ Hydraulic fluid reservoir level is correct.
- _____ Hydraulic connections are tight, and hoses and fittings are in good condition.
- _____ There are no hydraulic leaks.
- _____ Engine starts and runs, and fluid levels are correct.

- _____ Tire pressure is correct (see the tire sidewall).
- _____ Tires are in good condition.

Safety Checks

- _____ All safety sign decals are applied and legible.
- _____ All guards, shields, and covers are installed and secure.
- _____ Wheel lug nuts are tightened to the correct torque.
- _____ A retainer is installed through each hitch point.
- _____ Safety chains are on the ball-mount hitch.
- _____ Rear reflectors are present and not damaged.
- _____ Operating and safety instructions were reviewed.
- _____ All lights operate correctly (for example; running, brake, turn signal, license plate).

1.2 Serial Number Location

Always provide the model and serial number of your Wallenstein product when ordering parts, or requesting service or other information. The product information plate location is shown in the illustration.

Record the product Model and Serial Number in the spaces provided below for future reference.

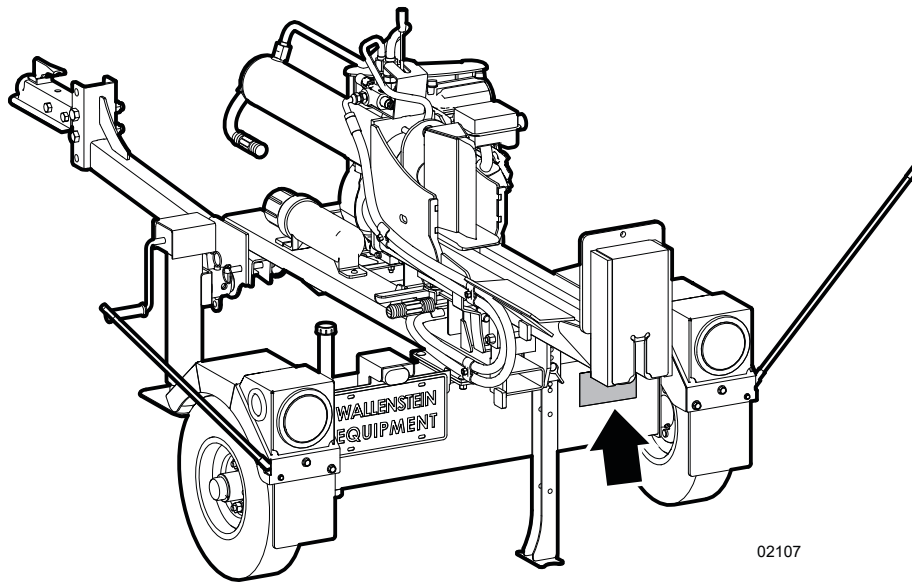

Figure 1 – Product Information plate location

Record Product Information Here	
Model:	WXR545PL
Serial Number:	

1.3 Decal Information

When getting familiar with the Wallenstein product, notice that there are numerous decals located on the machine. There are different types of decals for safety, information, and product identification. The following section explains what they are for and how to read them.

Safety Decals are pictorial with a yellow background and generally two panel. The top (or left-hand) panel shows the safety alert (the potential hazard), and the bottom (or right-hand) panel shows the message (how to avoid the hazard).

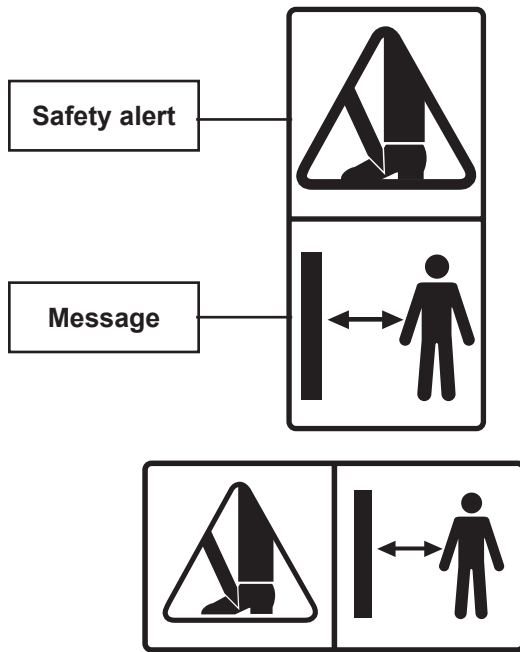

Safety Notice Decals are pictorial with a blue background and generally rectangular with single or multiple symbols. This decal informs what Personal Protective Equipment is required for safe operation.



Informative Decals are generally pictorial with a white background and can vary in the number of panels. This type of decal explains the operation of a control.

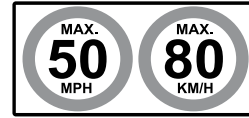

Product Decals indicate the machine model and serial number. For more product information, scan the quick response (QR) code.



Maintenance Decals have a green background and can vary to the number of panels. This decal shows the type of maintenance necessary and frequency interval.

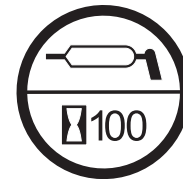

For safety sign decal definitions, see *Safety Sign Explanations on page 14*. For an illustration that shows all the decals and decal locations, go to WallensteinEquipment.com and download the Parts Manual for your Wallenstein product.

2. Safety

2.1 Safety Alert Symbol

This Safety Alert Symbol means:

ATTENTION! BE ALERT!

YOUR SAFETY IS INVOLVED!

The **Safety Alert Symbol** identifies important safety messages on the Wallenstein log splitter and in the manual. When you see this symbol, be alert to the possibility of personal injury or death. Follow the instructions in the safety message.



2.2 Signal Words

The signal words **DANGER**, **WARNING** and **CAUTION** determine the seriousness level of the warning messages in this manual. The appropriate signal word for each message in this manual has been selected using the following guidelines:

DANGER –

Indicates an imminently hazardous situation that, if not avoided, **will** result in death or serious injury. This signal word is to be limited to the most extreme situations typically for machine components which, for functional purposes, cannot be guarded.

WARNING –

Indicates a potentially hazardous situation that, if not avoided, **could** result in death or serious injury, and includes hazards that are exposed when guards are removed. It may also be used to alert against unsafe practices.

CAUTION –

Indicates a potentially hazardous situation that, if not avoided, **may** result in minor or moderate injury. It may also be used to alert against unsafe practices.

IMPORTANT – To avoid confusing equipment protection with personal safety messages, a signal word **IMPORTANT** indicates a situation that if not avoided, could result in damage to the machine.

2.3 Why Safety is Important



- **Accidents Disable and Kill**
- **Accidents Cost**
- **Accidents Can Be Avoided**

YOU are responsible for the SAFE operation and maintenance of your Wallenstein product. **YOU** must make sure that you and anyone else who is going to use, maintain, or work around the machine is familiar with the operating and maintenance procedures and related **SAFETY** information contained in this manual. This manual provides good safety practices that should be followed while using this machine.

Remember, **YOU** are the key to safety. Good safety practices not only protect you but also the people around you. Make these practices a working part of your safety program. Make sure that **EVERYONE** who uses this machine is familiar with the recommended operating and maintenance procedures and complies with all the safety precautions. Most accidents can be prevented.

Do not risk injury or death by ignoring good safety practices.

2.4 Safety Rules

- Give operating instructions to operators or employees before allowing them to operate the machine, and REVIEW annually thereafter.
- Read and understand ALL Safety and Operating instructions in the manual and follow them. The most important safety device on this equipment is a SAFE operator. 
- Review safety related items annually with all personnel who are operating the machine or performing maintenance
- Wear appropriate Personal Protective Equipment (PPE). The suggested equipment includes but is not limited to the following:
 - Hearing Protection
 - Protective glasses, goggles or face shield
 - Heavy work gloves
 - Protective shoes with slip resistant soles
- Keep a first-aid kit available for use should the need arise and know how to use it. 
- Read and understand all safety signs located on the machine before operating, servicing, adjusting, or cleaning.
- Inspect and secure all guards before starting.
- Check engine intake and exhaust. Make sure they are clear of debris prior to starting the machine.
- Inspect and secure all guards before starting.
- Have a fire extinguisher available for use should the need arise. Know how to use it. 
- Do not touch hot engine parts, muffler cover, hydraulic hoses, engine body, engine oil, and so on during operation or if the engine was recently shut off. Contact may cause burns.
- Do not expect a person who has not learned all operation and safety instructions to use the machine. An untrained operator is not qualified and is exposed to possible serious injury or death. It is the owner's responsibility to make sure to the operator has familiarity and understanding of the machine.
- Do not allow riders during transport.
- Do not risk injury or death by ignoring good safety practices. Think SAFETY! Work SAFELY!

2.5 Equipment Safety Guidelines

Always place the machine in a **Safe Condition** before performing any service work, maintenance procedures, or storage preparation.

SAFE CONDITION

- Stop the engine.
 - Make sure all moving parts have stopped.
 - Remove the wire from the spark plug. Keep the wire away from the spark plug.
 - Block the wheels.
- Never use equipment with safety shields removed. Keep all shields in place. If shield removal becomes necessary for repairs, reinstall the shield prior to use.
 - Replace any safety sign or instruction sign that is not readable or is missing. Location of safety signs is indicated in this manual.
 - Do not allow anyone other than a responsible, properly trained and physically able person to operate this machine. This equipment is dangerous to children and persons unfamiliar with its operation.
 - Do not modify the equipment in any way. Unauthorized modification may result in serious injury or death and may impair the function and life of the equipment.
 - Never exceed the limits of the machine. If its ability to do the job or to do it safely is in question—**STOP IMMEDIATELY!**

2.6 Safety Training

- The best safety feature is an informed, careful operator—we ask you be that kind of operator. It is the operator's responsibility to read, understand and follow ALL safety and operation instructions in the manual.
- 
- Train all new personnel and review instructions frequently with existing workers. Only properly trained and physically able operators should use this equipment. **A person who has not read and understood all operation and safety instructions is not qualified to use the machine.** Untrained operators expose themselves and bystanders to possible serious injury or death. If elderly people are assisting with the work, their physical limitations need to be recognized and accommodated.

- Learn the controls and how to stop the machine quickly in an emergency.
- If this machine is loaned or rented, it is the machine owner's responsibility to make certain that every operator:
 - Reads and understands the owner's manual
 - Is instructed in safe and proper use of the equipment
 - Understands and knows how to perform the Safe Condition procedure

2.7 Refueling Safety

- Engine fuel is highly flammable. Handle with care.
 - Fill fuel tank outdoors.
 - Stop the engine before refueling. Allow engine to cool for five minutes. Clean up spilled fuel before restarting engine.
 - Do not overfill the fuel tank.
 - If fuel is spilled, wipe it away carefully and wait until the fuel has dried before starting the engine.
 - Do not refuel the machine while smoking or when near open flame or sparks.
- 
- After refueling, make sure that the fuel cap is secured to prevent spillage.
 - Prevent fires by keeping machine clean of accumulated trash, grease, and debris.

2.8 Tire Safety

- Failure to follow proper procedures when mounting a tire on a wheel or rim can produce an explosion which may result in serious injury or death.
- Do not attempt to mount a tire unless you have the proper equipment and experience to do the job.
- Have a qualified tire dealer or repair service perform required tire maintenance.
- When replacing worn tires, make sure they meet the original tire specifications. Never install undersized tires.

2.9 Hydraulic Safety

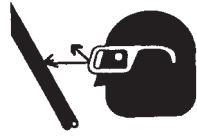
- Make sure that all the components in the hydraulic system are kept in good condition and are clean.
- Before applying pressure to the system, make sure all components are tight, and that lines, hoses and couplings are not damaged. 
- Do not attempt any makeshift repairs to the hydraulic lines, fittings or hoses by using tapes, clamps or cements. The hydraulic system operates under extremely high pressure. Such repairs can fail suddenly and create a hazardous and unsafe condition.
- Wear proper hand and eye protection when searching for a high-pressure hydraulic leak. Use a piece of wood or cardboard as a backstop instead of hands to isolate and identify a leak. 
- If injured by a concentrated high-pressure stream of hydraulic fluid, seek medical attention immediately. Serious infection or toxic reaction can develop from hydraulic fluid piercing the skin surface.
- Relieve pressure in the hydraulic system before working on it.

2.10 Engine Safety

CAUTION!

Before starting the engine, review the safety, operating, and maintenance instructions in the engine manual.

W019

IMPORTANT! In some regions, when an engine is used on any forest covered, brush covered, or grass covered unimproved land it is required by law to have a spark arrestor installed on the muffler. A spark arrestor traps exhaust particles that are expelled from the engine. It is the responsibility of the operator to comply with the local laws and regulations. To purchase a spark arrestor, contact your local Wallenstein dealer or distributor.

- **DO NOT** refuel indoors where area is not well ventilated.
- **DO NOT** refuel while engine is running. Allow engine to cool for five minutes before refueling. Store fuel in approved safety containers.
- **DO NOT** remove fuel tank cap while engine is running.
- **DO NOT** operate engine if gasoline is spilled. Move machine away from the spill and avoid engine ignition until gasoline has evaporated.
- **DO NOT** smoke while filling fuel tank.
- **DO NOT** choke carburetor to stop engine. Whenever possible, gradually reduce engine speed before stopping.
- **DO NOT** run engine above rated speeds. This may result in injury.
- **DO NOT** tamper with governor springs, governor links or other parts which may increase the governed speed.
- **DO NOT** tamper with the engine as set by the original equipment manufacturer.
- **DO NOT** check for spark with spark plug or spark plug wire removed.
- **DO NOT** crank engine with spark plug removed. If engine is flooded, crank until engine starts.
- **DO NOT** strike flywheel with a hard object or metal tool as this may cause flywheel to shatter in operation. Use proper tools to service engine.
- **DO NOT** operate engine without a muffler. Inspect periodically and replace, if necessary.
- **DO NOT** operate engine with an accumulation of grass, leaves, dirt or other combustible materials in the muffler area.
- **DO NOT** touch hot muffler, engine body or cooling fins. Contact may cause burns.
- **DO NOT** run engine with air cleaner or air cleaner cover removed.

Be sure to:

- Remove the wire from the spark plug when servicing the engine or equipment to prevent accidental starting.
- Keep engine cooling fins and governor parts free of grass and other debris that can affect engine speed.
- Examine muffler periodically to be sure it is functioning effectively. A worn or leaking muffler should be repaired or replaced as necessary.
- Use fresh gasoline. Old fuel can clog carburetor and cause leakage.
- Check fuel lines and fittings frequently for cracks or leaks. Replace if necessary.

- **DO NOT** operate engine in an enclosed area. Exhaust gases contain odorless and deadly carbon monoxide that can cause death by asphyxiation.
- **DO NOT** place hands or feet near moving or rotating parts.
- **DO NOT** store, spill, or use gasoline near an open flame, or devices such as a stove, furnace, or water heater which use a pilot light or devices which can create a spark.

2.11 Be Prepared

- Determine where the split wood is going to be piled ahead of time. Make sure it does not interfere with safe loading of wood into the splitter.
- Precut logs so wood is ready to load into the splitter. Do not run a chainsaw and the splitter at the same time.
- Determine a safe work area location:
 - Area must be clear of stones, branches or hidden obstacles that might cause a tripping, hooking or snagging hazard.
 - Ground should be firm and level.
- Operate only in daylight or good artificial light.
- Make sure machine is properly adjusted and in good operating condition.
- Store fuel well away from the wood pile.
- Perform the **Pre-operation Checklist** procedure before starting work (see *on page 23*).
- Do not operate on hillsides or when working area is cluttered, wet, muddy or icy to prevent slipping and tripping. Operate only on level ground.
- Position machine so prevailing winds blow engine exhaust fumes away from operator's station.
- Do not operate machine inside a closed building to prevent asphyxiation from engine exhaust.
- Stop engine when leaving the machine unattended.

3. Safety Signs

WARNING!

Risk of personal injury. Replace safety signs that are removed, damaged, or illegible. If a part with a safety sign on it is replaced, a new safety sign must be applied.

W100

3.1 Safety Sign Locations

The types of safety signs and locations on the equipment are shown in the illustrations that follow. Good safety requires that you familiarize yourself with the various safety signs, the type of warning and the area, or particular function related to that area, that requires your SAFETY AWARENESS.

Think SAFETY! Work SAFELY!

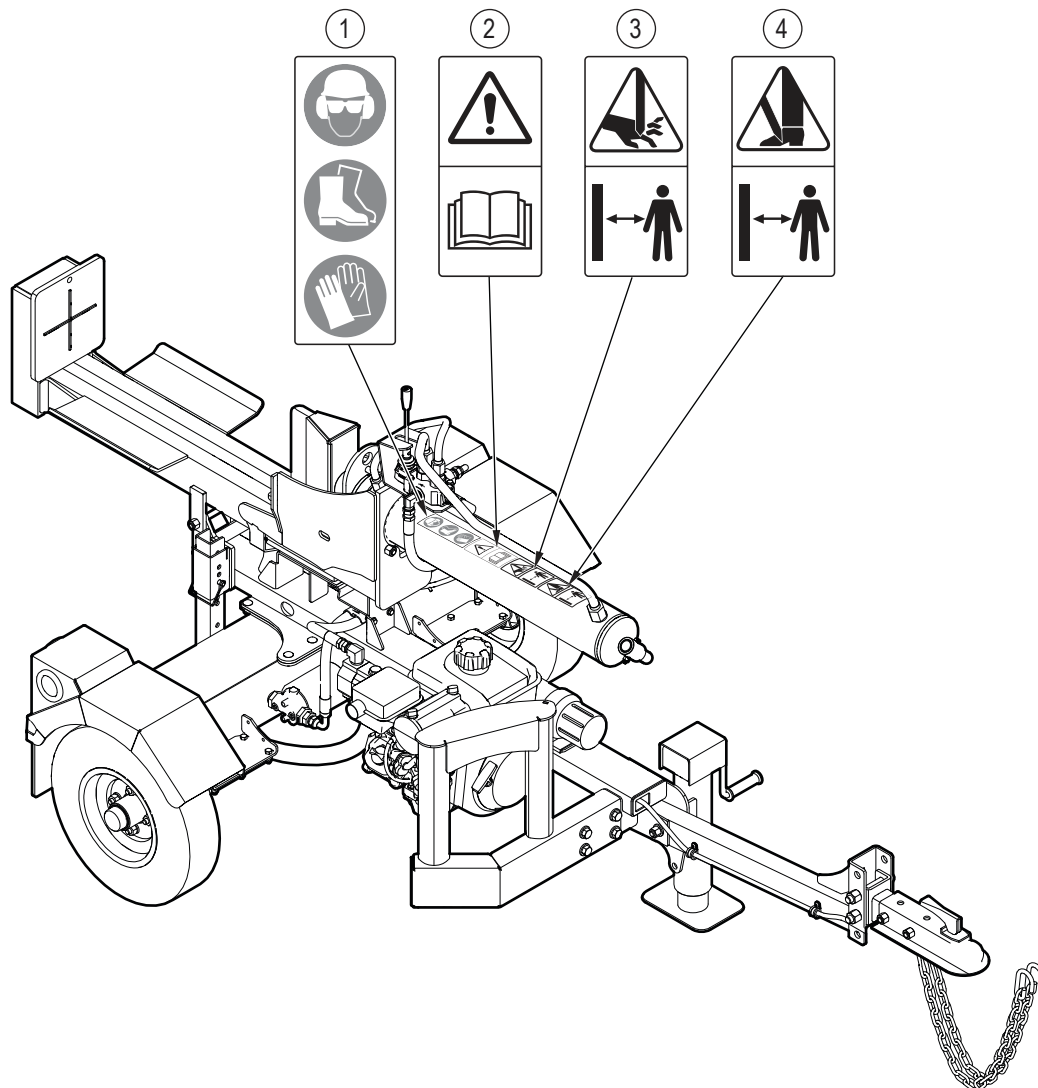

Figure 2—Safety sign locations

3.2 Safety Sign Explanations

1. WARNING!

Always wear appropriate Personal Protective Equipment when using this machine. For example:

- A hard hat
- Heavy gloves
- Hearing protection
- Protective shoes with slip resistant soles
- Protective glasses, goggles or face shield



2. CAUTION!

Refer to the operator's manual. Read ALL operating instructions in the manual and learn the meaning of ALL safety signs on the machine.

The best safety feature is an informed operator.

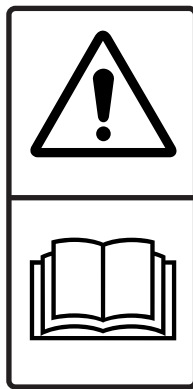

3. WARNING!

Pinch point / crushing danger! Keep your hands away from all moving parts during and after split operation! Never try to clear a jammed log with your hands! Wait for all moving parts to come to a complete stop before loading or clearing obstructions.



4. WARNING!

Keep feet away from falling split wood. Always wear steel toed foot wear while machine is operating to avoid serious personal injury.



IMPORTANT! If parts are replaced that have safety signs on them, new signs must be applied. Safety signs must always be replaced if they become damaged, are removed, or become illegible.

Safety signs are included in the product decal kit available from your authorized dealer. Decals are not available separately.

3.2.1 Replacing Damaged Safety Signs

- Always keep safety signs clean and legible.
- Replace safety signs that are missing or have become illegible.
- Parts that were replaced with a safety decal on them must also have the safety sign replaced.
- Replacement safety signs are available from your authorized Distributor, Dealer Parts Department, or Wallenstein Equipment.

Procedure

1. Be sure that the installation area is clean and dry.
2. Be sure temperature is above 50 °F (10 °C).
3. Determine exact position before removing from the backing paper.
4. Pull the decal off the backing sheet, align the sign over the specified area, then carefully press the exposed sticky backing in place.
5. Use a piece of the backing paper to smooth the decal out, pressing from the center outwards.
6. Small air pockets can be pierced with a pin and smoothed out using the piece of sign backing paper.

4. Familiarization

4.1 To the New Operator

It is the responsibility of the owner or operator to read this manual and to train all other operators before they start working with the machine. Follow all safety instructions exactly.

By following recommended procedures, a safe working environment is provided for the operator, bystanders and the area around the work site. Untrained operators are not qualified to use the machine.

Many features incorporated into this machine are the result of suggestions made by customers like you. Read this manual carefully to learn how to use the machine safely and provide maximum operating efficiency. By following the instructions in conjunction with a good maintenance program, your log splitter can provide many years of trouble-free service.

IMPORTANT! Make sure all operators understand how to put the log splitter in a Safe Condition before working with this machine. See Safe Condition on *page 9*.

4.1.1 Training

Each operator must be trained in the proper set-up and operating procedures before using the machine.

1. Move the unit to a large open area to allow the operator to become familiar with control functions and machine response.
2. Do not allow untrained operators to use the machine. They can endanger themselves and others, or damage property and the machine.

4.1.2 Job Site Familiarization

It is the responsibility of the operator to be thoroughly familiar with the work site prior to starting.

1. Check for close or cramped work space. Be sure there is sufficient space and clearance for the machine to operate.
2. Organize the working area to minimize movement.
3. Position the machine so prevailing winds blow engine exhaust fumes away from operator's station.

4.2 Machine Components

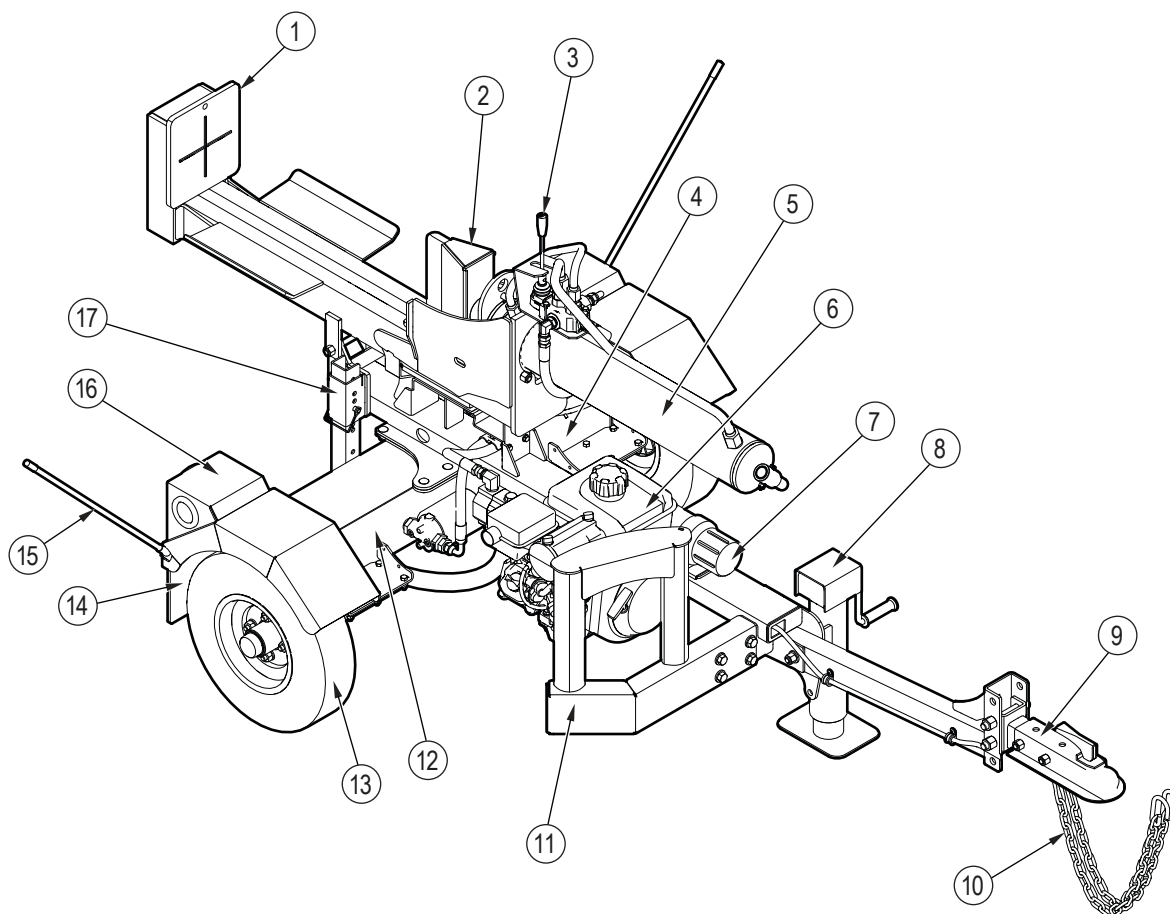

02086

Figure 3—WXR545PL log splitter components

1. Tiltting splitter bed
2. Splitting wedge
3. Splitter control lever
4. Splitter bed spring latch
5. Hydraulic cylinder
6. Engine
7. Operator's Manual storage tube
8. Front jack stand
9. Trailer tongue
10. Safety chains
11. Engine guard
12. Hydraulic fluid reservoir
13. 4.80-8 LRB SportTrail tire
14. Mud flap
15. Width guides
16. Lights
17. Rear jack stand

5. Controls

WARNING!

Do not operate the machine until you are thoroughly familiar with the position and function of the various controls. Read the operator's manual thoroughly. Your safety is involved!

W065

5.1 Engine Controls

WARNING!

Before starting the engine, read and understand the safety and operating information under *Engine Safety on page 10*.

IMPORTANT! For complete information about the engine controls, see the engine manufacturer's manual.

5.1.1 Throttle Control and Fuel Shutoff

The throttle control and fuel shutoff lever has the following functions:



Fast
Engine speed is fast.



Slow
Engine speed is slow.



Fuel shutoff closed



STOP
The engine is stopped.

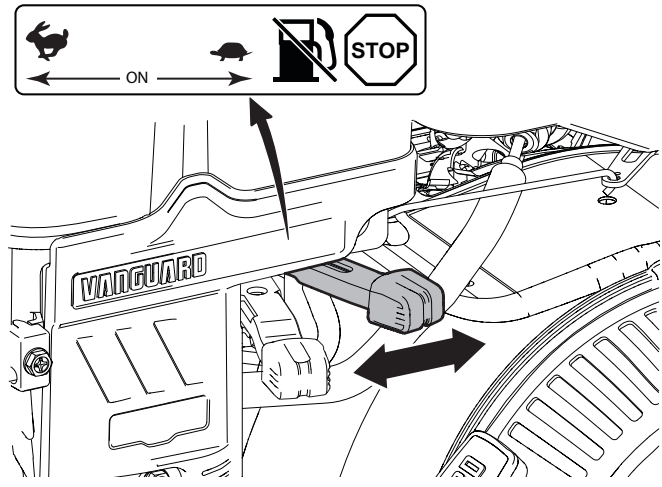
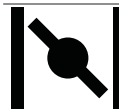

Figure 4—Engine throttle control and fuel shutoff

5.1.2 Choke Control

The choke control lever has the following functions:



Closed
Close the choke to start a cold engine.



Open
Open the choke when the engine is warm.

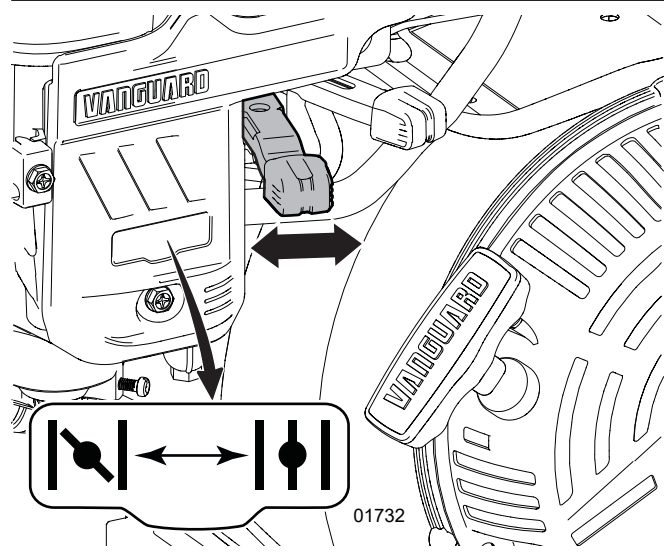

Figure 5—Engine choke control

5.1.3 Rewind Start

! WARNING!

Fast retraction of the starter cord (called kickback) pulls your hand and arm toward the engine faster than you can let go of the handle. Serious bodily harm (for example; bruises, sprains, fractures, and broken bones) can result.

When starting the engine, pull the starter cord slowly until you feel resistance, and then pull it rapidly to avoid kickback.

W102

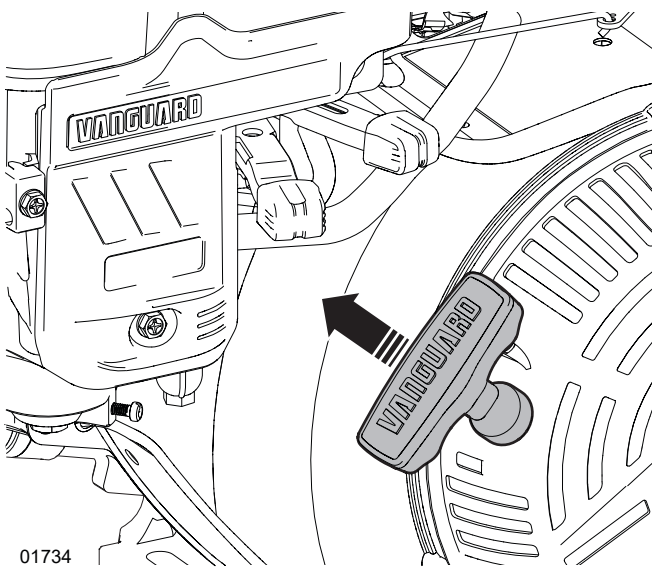

01734

Figure 6—Rewind-start handle

5.2 Splitter Control

The WXR Series log splitters are equipped with **2X2-Speed FIREBOLT** technology. The FIREBOLT system consists of a two-stage hydraulic pump and a regenerative control valve.

The splitter control has two extend positions that provide either High speed (2) or High power (1).

When retracting the splitter control, the lever is held back automatically until the splitting wedge or push block returns, providing hands-free operation.

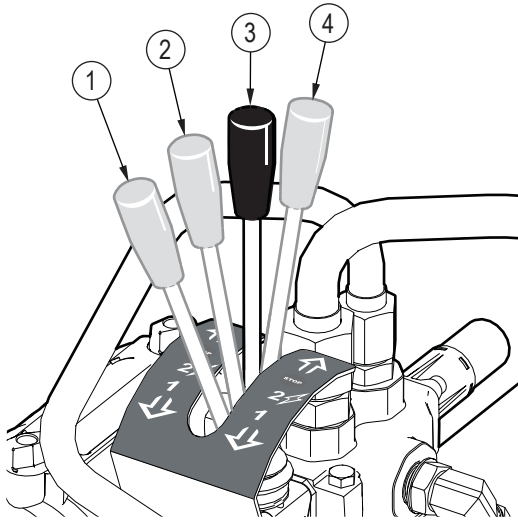

Figure 7—Splitter-control valve

1. High power
2. High speed
3. Stop
4. Retract

High Power Position

- Push the splitter-control lever fully forward to the high power position for maximum power. The cylinder extends at a slower speed but provides higher power to push the wedge or push block through the wood.
- Releasing the lever returns it to the stop position.

High Speed Position

- Pushing the lever forward to the high speed position provides a higher cylinder extension speed. In this position the cylinder extends at high speed, but lower power.
- Releasing the lever returns it to the stop position.

Stop Position

- The stop position is when the splitter-control valve is in neutral. The wedge or push block stops moving when the lever is moved to this position. The valve lever spring-returns to the stop position when released from either the extend position, or auto-retract.
- The splitter-control lever can be moved to stop at any time.

Retract Position

- Pull the lever fully backwards to retract the wedge or push block. The splitter-control valve holds the lever in retract allowing a hands-free return cycle.
- The valve lever returns to the stop position when wedge or push block is fully retracted.
- The lever can be moved out of the retract position and into the stop position at any time.

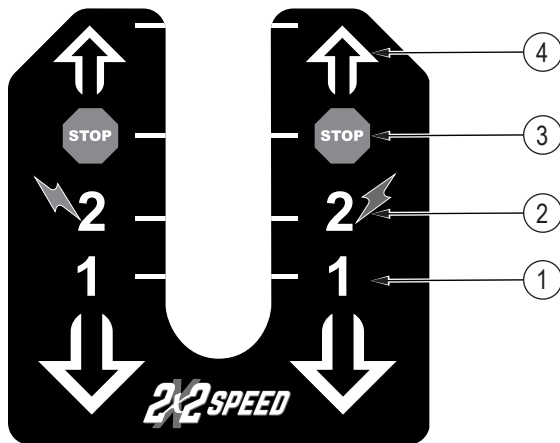

Figure 8—Splitter controls

1. High power
2. High speed
3. Stop
4. Retract

5.3 Stroke Limiter Accessory

The Stroke Limiter accessory improves productivity when splitting shorter pieces. It stops the cylinder from fully returning to the home position.

5.3.1 Stroke Limiter Adjustment

1. Place a typical sized log on the splitter bed, then start the log splitter.
2. Using the hydraulic control, move the splitting wedge up to the log, but stop approximately 3" (8 cm) from it.
3. Shut off the engine. Make sure the splitter-control lever is in the stop position.
4. Loosen the hex set screw on the rod adjusting collar, and move the rod up to the splitting wedge or push block (this is the set position at which the splitting wedge or push block stops on the return cycle). Tighten the hex screw.
5. Test the set up by cycling the splitting wedge through its path. Split a log then put the hydraulic lever into the retract position. The lever should trip the hydraulic control and the splitting wedge should stop at the set position. Adjust as required.

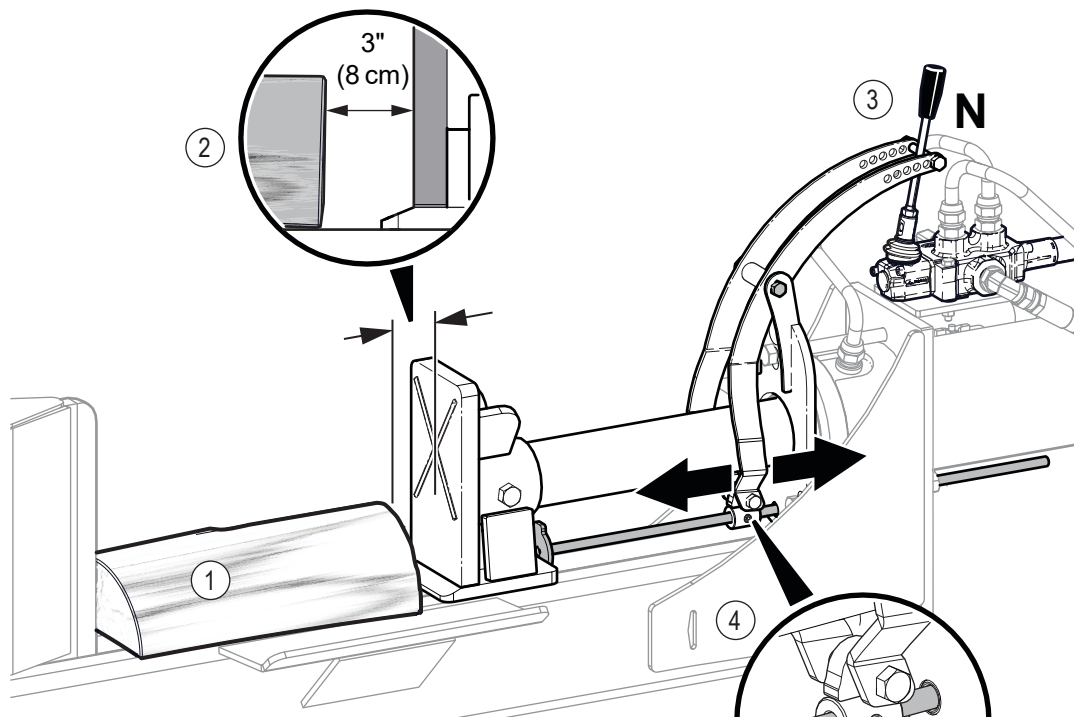

Figure 9—Set the stroke limiter accessory

5.4 Splitter Bed Spring Latch

Use the splitter bed spring latch to turn the splitter bed. The splitter bed can be turned to split wood horizontally, vertically, or on an angle.

5.4.1 Turn the Splitter Bed

1. Pull and hold the splitter bed spring latch to release the lock mechanism.
2. Use the handle to turn the splitter bed.
The angled position is 20 degrees from the horizontal position.
The vertical position is 90 degrees from the horizontal position.
3. When the splitter bed is in position, release the splitter bed spring latch.

Image of spring latch and handle

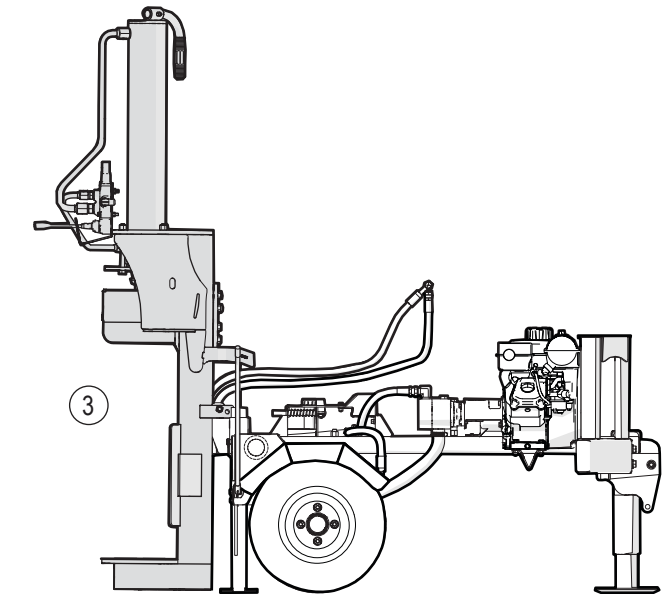
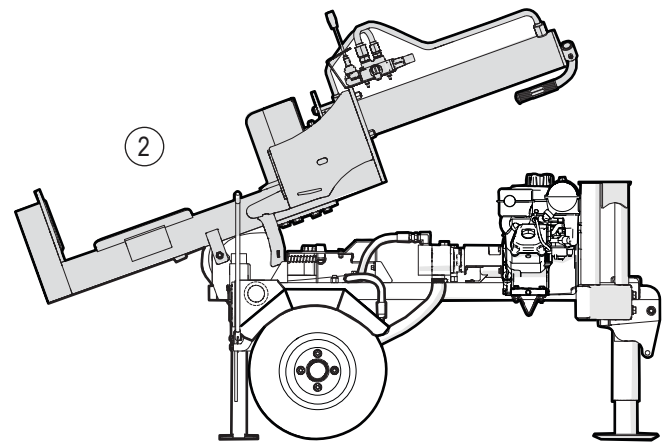
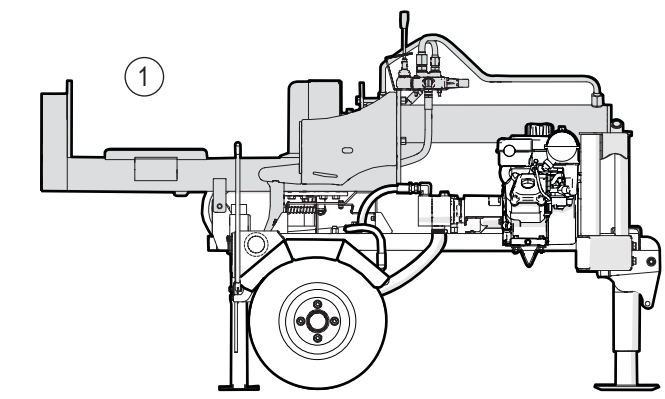

Figure 10—Splitter bed positions

1. Horizontal
2. Angled
3. Vertical

6. Operating Instructions

Wallenstein WXR Series log splitters are self-contained machines designed to push wood through a wedge to split it. The WXR545PL splitter can be used in the vertical, angled, or horizontal configuration.

The operator has the responsibility of being familiar with all operating and safety procedures and following them.

6.1 Operating Safety

Read and obey the safety signs on the machine. Clean or replace them if they are not legible.

There is no substitute for a cautious, safe-minded operator who recognizes potential hazards and follows reasonable safety practices. This machine must be used with all its safety equipment properly installed to minimize the chance of accidents.

- Wear appropriate personal protective equipment. Tie back long hair, remove jewelry, and avoid loose fitting clothing. Prolonged exposure to loud noise can cause permanent hearing loss! Wear hearing protection on a full-time basis when using this machine.
 - The operator must be in control of the machine at all times. Read and understand owner's manual before starting. Review safety instructions annually.
 - Never use engine-powered machinery indoors. Gas engine exhaust contains toxic carbon monoxide, which cannot be smelled or seen. Breathing carbon monoxide can be lethal.
 - Make sure all guards, deflectors and shields are in place before starting and operating.
 - Keep hands out of splitting area. Do not rest hands on the log being split.
 - Do not step over or straddle splitter during operation.
 - Do not try to split more than one log at a time. The logs can fly out and cause injury.
 - Keep your fingers and hands away from cracks in the log that can open while splitting.
 - Always load logs by grasping the bark side, not the cut ends.
 - Do not reach into or load the splitter when the wedge is in motion.
 - Do not try to split logs across the grain. Some types of wood can burst or splinter causing pieces to be thrown causing injury.
 - For uneven cut logs, always place the square cut end against the splitting wedge.
- Never place any part of your body where it would be in danger if machine movement should occur during assembly, installation, operation, maintenance, repairing or moving.
 - Before servicing or repairing the machine, place it in a **Safe Condition**. See *page 9*.

6.2 Before Starting the Engine

1. Check the engine oil level. See *page 24*.
2. Check the hydraulic fluid level. See *page 25*.
3. Check the fuel level. See *page 25*.
4. Check the engine air filter. See *page 39*.
5. Review the Safety Rules on *page 8*.
6. Clear the area of bystanders, especially small children.
7. Make sure each operator is trained and familiar with the set up and operation of the log splitter.
8. Follow the Pre-Operation Checklist.
9. Review the Controls. See *page 17*.
10. Survey the work site and place the log splitter in a clear, level work area.
11. Set up the machine. See *Machine Setup on page 26*.

6.3 Pre-operation Checklist

Efficient and safe operation of the Wallenstein log splitter requires that each operator reads and understands the operating procedures and all related safety precautions outlined in this section.

A Pre-operation Checklist is provided for the operator. The checklist is important for both personal safety and keeping the log splitter in good mechanical condition.

Before operating the machine and each time thereafter, the following areas should be checked off:

Pre-operation Checklist	✓
Check engine oil level. Top level up as required.	
Check hydraulic fluid level. Top level up as required.	
Check and lubricate the machine following the schedule outlined in the Maintenance section.	
Check the wedge and block. Be sure they are not damaged or broken and is not badly worn. Repair or replace as required.	
Check and remove any entangled material.	
Check for hydraulic leaks. Tighten connections or replace components to stop leaks.	
Check and ensure that all covers, guards and shields are in place, secured, and can function as designed.	
Check and inspect tires, wheels, and hubs.	
Check and tighten all fasteners. Make sure the equipment is in good condition.	
Check that appropriate equipment for personal protection is being used and in good condition.	
Check that jewelry, loose-fitting clothing are not worn. Make sure long hair is tied back.	

6.4 Machine Break-In

Although there are no operational restrictions on the log splitter when used for the first time, it is recommended that the following items be checked:

Review the engine owner's manual for break-in recommendations. Place the machine in a **Safe Condition** before checking any components. To see how to do that, refer to *Safe Condition on page 9*.

After One Hour of Operation

1. Check that the push block or wedge is adequately lubricated.
2. Check all nuts, bolts and other fasteners. Tighten to their specified torque level.
3. Check hydraulic system for leaks. Tighten all leaking fittings and replace any leaking components.
4. Check machine fluid levels—Fuel, engine oil, and hydraulic fluid reservoir. Top up as required.
5. Check for entangled material. Remove all entangled material before resuming work.
6. Check tire pressure. Inflate as required.

After Five Hours of Operation

- Change the engine oil.
For instructions, see the engine manufacturer's manual.

After Eight Hours of Operation

- Complete the tasks listed under *After One Hour of Operation*.

6.5 Check the Engine Oil Level

IMPORTANT! For more information about engine oil, see the engine manufacturer's manual and *Engine Oil on page 34*.

Operating the engine with a low oil level can cause engine damage that is not covered by the warranty.



The engine must be in a level position for the dipstick to show the oil level correctly.

Check the engine oil level before each use.

1. Park the machine on level ground.
2. Stop the machine.
For instructions, see *Stop the Machine on page 27*.
3. Pull out the oil-level dipstick and wipe it clean.
4. Fully insert the oil-level dipstick.
5. Pull out the oil-level dipstick and check the oil level.
The oil level is correct when oil is visible on the dipstick from the end to the full (upper) mark.
6. Do one of the following:
 - If the oil level is correct, continue with step 7.
 - If the oil level is low, add oil until the oil-level is at the full (upper) mark. For instructions, see *Add Oil to the Engine*.
7. Insert and secure the oil-level dipstick.

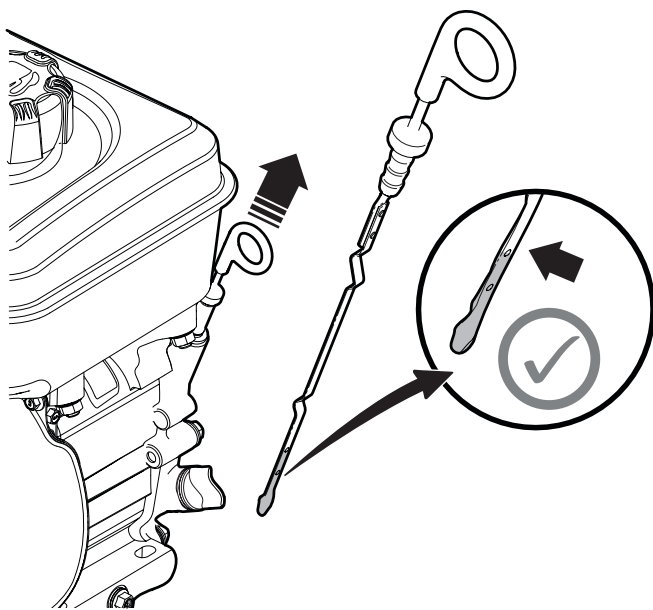

Figure 11—Check the engine oil level

6.5.1 Add Oil to the Engine

IMPORTANT! For more information about engine oil, see the engine manufacturer's manual and *Engine Oil on page 34*.

The engine has three oil-fill locations. The two most accessible locations are shown in the following image. The third location is on the opposite side of the engine, below the dipstick.

1. Check the engine oil level to make sure that the oil level is low. For instructions, see *Check the Engine Oil Level*.
2. Turn an oil-fill cap counterclockwise to remove it.
3. Use a clean funnel to slowly add the correct type and amount of oil. **Do not overfill.**
4. Wait a minimum of one minute.
5. Remove the funnel, and then check the engine oil level.
6. Install and secure the oil-fill cap to prevent spillage.

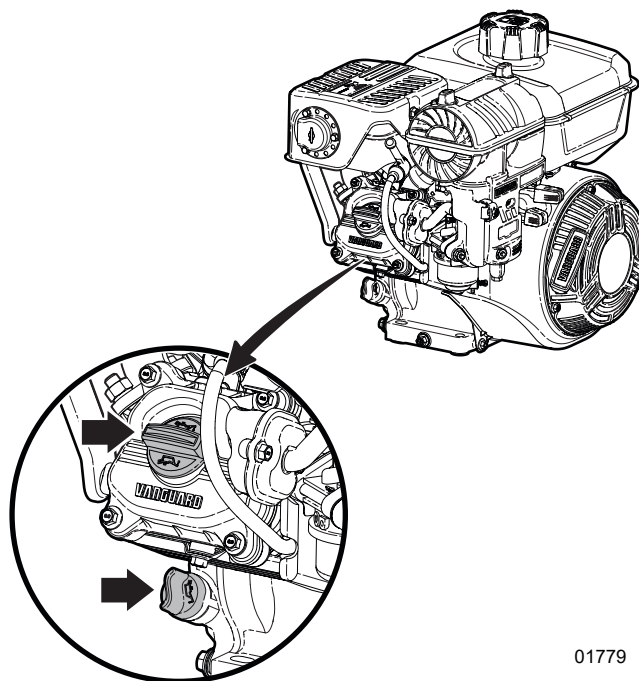

01779

Figure 12—Engine oil-fill locations

6.6 Check the Hydraulic Fluid Level

Check hydraulic fluid level every 40 hours or weekly.

Check with the machine parked on level ground and the engine stopped.

The proper level is when the fluid is visible at the full (upper) mark on the dipstick.

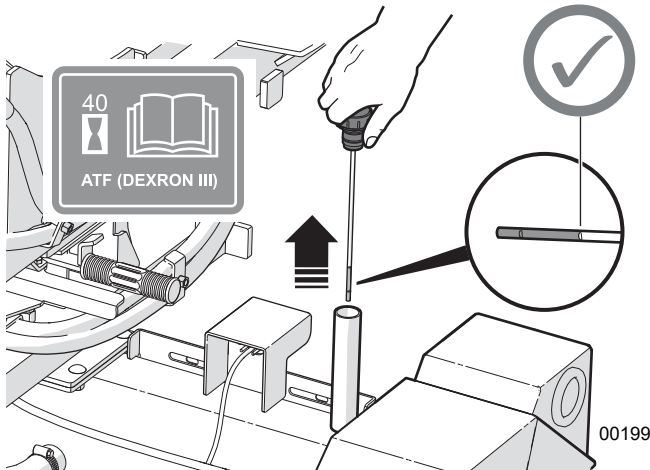

Figure 13—Hydraulic fluid tank level dipstick

IMPORTANT! Do not operate machine if the fluid level is not visible on the dipstick. The pump and other components can be damaged.

Do not overfill the tank past the full mark.

IMPORTANT! Always check fluid levels after changing filters or servicing hydraulic components.

IMPORTANT! The hydraulic fluid quality should be inspected every 40 hours. If the fluid is dirty or smells burnt, it should be replaced.

IMPORTANT! Be aware of high fluid temperatures. Temperatures higher than 180 °F (82 °C) could cause seal damage and degrade fluid quality.

6.6.1 Add Hydraulic Fluid

The hydraulic system uses **Dexron® III ATF**.

1. Clean the area around filler cap and remove it.
2. Use a clean funnel and add fluid until the level is at the full mark on the dipstick.
3. Install filler cap securely. Wipe up any spilled fluid.

6.7 Check the Fuel Level

Check the fuel level daily.

Starting with a full tank helps to eliminate or reduce operating interruptions for refueling.

The fuel tank is located on the engine. Avoid running the tank dry.

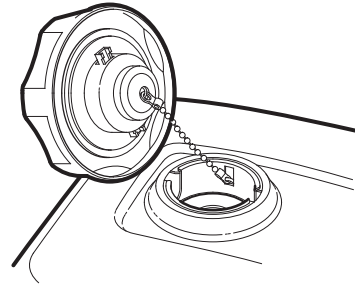

Figure 14—Fuel cap

6.7.1 Add Fuel to the Engine

Fuel tank capacity: **0.82 US gal (3.1 L)**.

! WARNING!



Never smoke or vape while working with fuel. Fuel vapors can explode causing injury or death. Keep sparks, flames, and hot components away.

W027

Refuel in a well-ventilated area with the engine stopped. If the engine has been running, allow it to cool first. Never refuel the engine inside a building where gasoline fumes can come in contact with flames or sparks.

For fuel specification, see *Fluids and Lubricants* on page 34. Refer to the engine manual for additional information on fuels.

1. Clean the area around fuel tank cap. **Fill the tank to 1/2" (12 mm) below bottom of filler neck to provide space for any fuel expansion.** Do not overfill.
2. Install fuel fill cap securely and wipe up any spilled fuel.

6.8 Machine Setup

IMPORTANT! Park the log splitter on a level, dry work area free of debris and other objects.

Position the splitter so the prevailing wind blows engine exhaust away from the operator.



If using a tow vehicle, leaving the splitter attached to it provides greater stability.

1. Position the splitter next to the wood to be split.
2. If no tow vehicle is available, lower the front jack stand and the rear jack stand. You can block the wheels for more stability.
3. Make sure working area is clear of stones, branches or other obstacles.
4. Precut logs to desired block size, ready to load onto splitter bed.
5. Determine where the split wood is going to be piled. Make sure that the location does not interfere with loading the splitter.

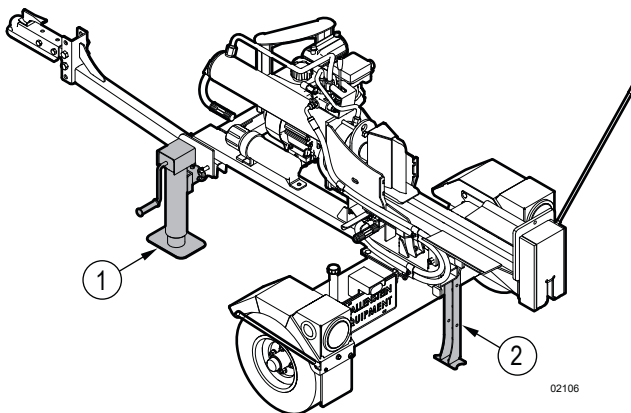

Figure 15—Setup the machine

1. Front jack stand
2. Rear jack stand

6.9 Start the Machine



WARNING!

Fast retraction of the starter cord (called kickback) pulls your hand and arm toward the engine faster than you can let go of the handle. Serious bodily harm (for example; bruises, sprains, fractures, and broken bones) can result.

When starting the engine, pull the starter cord slowly until you feel resistance, and then pull it rapidly to avoid kickback.

W102



WARNING!

Before you start the machine, read and understand all of the safety information in this manual and the engine manufacturer's manual.

IMPORTANT! If the engine does not start after repeated attempts, contact your local dealer or go to VanguardPower.com.

Before you start the machine, see the information under *Controls* on page 17.

1. Complete the tasks described in the *Pre-operation Checklist* on page 23.
2. Make sure that the machine is set up correctly, level, and in a stable position.
3. Move the hydraulic controls to the neutral position (out of detent).
4. Move the choke control to the **Closed** position.
5. Move the throttle control to the **Fast** position.
6. Firmly grip the starter-cord handle.
7. Pull the starter cord out slowly until you feel resistance, and then pull it rapidly.
8. When the engine warms up, move the choke control to the **Open** position.

6.10 Stop the Machine

IMPORTANT! Do not choke the carburetor to stop the engine.

1. Stop loading material onto the splitter bed.
2. Move the hydraulic controls to neutral.
3. Move the engine throttle control to the **STOP** position to turn off the engine and close the fuel shutoff valve.
4. Activate each hydraulic control two or three times to relieve the hydraulic system pressure.

6.11 Emergency Stop

In the event of an emergency:

1. Move the hydraulic controls to neutral.
2. Move the engine throttle control to the **STOP** position to turn off the engine and close the fuel shutoff valve.
3. Remove the cause of the emergency before starting the engine and resuming work.

6.12 Log Placement

! WARNING!

Risk of pinching or crushing hazard between the wedge or push block and the log!

**Never place hands at the ends of the log.
Always grasp logs by the sides when loading or removing.**

W035

- **Always grasp the log by the sides not the ends when placing in or removing logs from the splitter.** This minimizes the chance of the operator getting fingers, hands or arm between the wedge / push block and the log.
- Any logs or debris remaining on the splitter bed should only be removed after it is safe to do so.

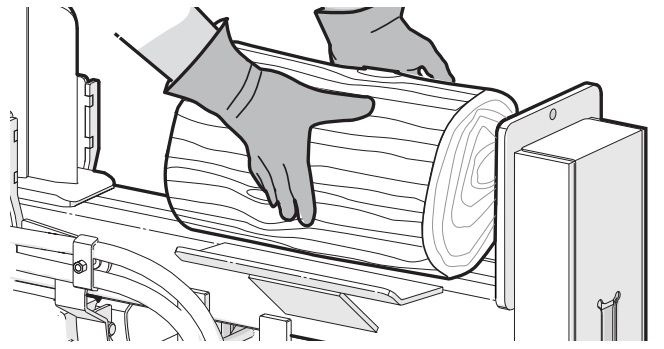

Figure 16—Correct log placement

6.13 Split Wood

WARNING!

Hands can be pinched, cut, crushed, or severed. If two or more people load or operate the machine together, a person can be seriously injured.

Only one person must load and operate the machine.

W036

IMPORTANT! Do not hold the splitter-control lever to extend or retract the cylinder once it has reached the end of its stroke. Doing so can overheat the fluid and could damage the engine.

The WXR545PL log splitter can split wood in three different positions: Horizontally, vertically, or on an angle. To change the splitter bed position, see *Splitter Bed Spring Latch* on page 21.

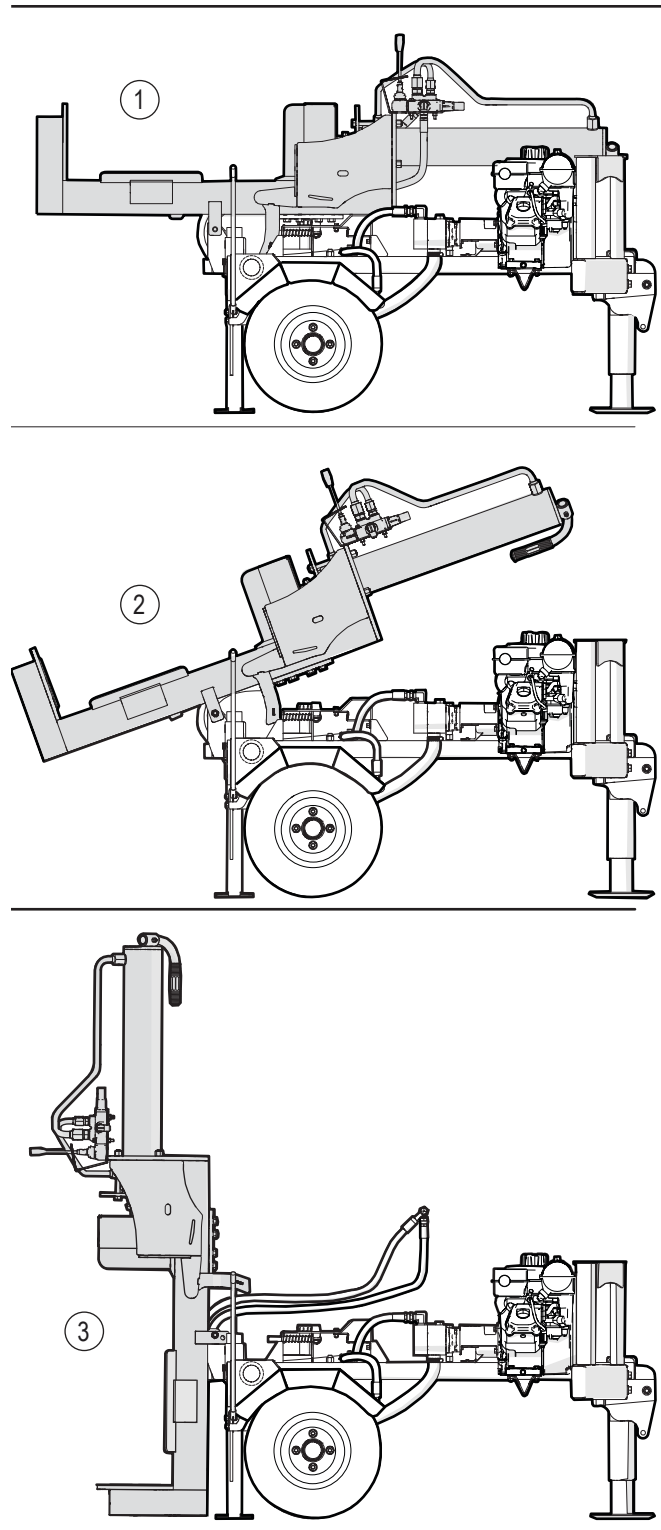

Figure 17—Splitter bed positions

1. Horizontal
2. Angled
3. Vertical

6.13.1 Split Wood Horizontally

WARNING!

Hands can be pinched, cut, crushed, or severed. If two or more people load or operate the machine together, a person can be seriously injured.

Only one person must load and operate the machine.

W036

1. Put wood or a log on the splitter.
2. Move control lever to the **High speed** position until push block or wedge starts to split the wood.
3. If the wedge slows, push control lever forward to **High power** position and hold to split wood.
4. Release the lever when the log splits or cylinder reaches full stroke and stops.
5. Pull the lever to the **Retract** position to retract the push block or splitting wedge. The detent holds the lever until the cylinder fully retracts, allowing hands-free operation.
6. If the log is large enough to require another split, reposition and repeat steps 1-5.
7. Pile the split wood close to the working area, but do not allow pieces to pile up and clutter the area. A cluttered working area can lead to tripping and an accident.

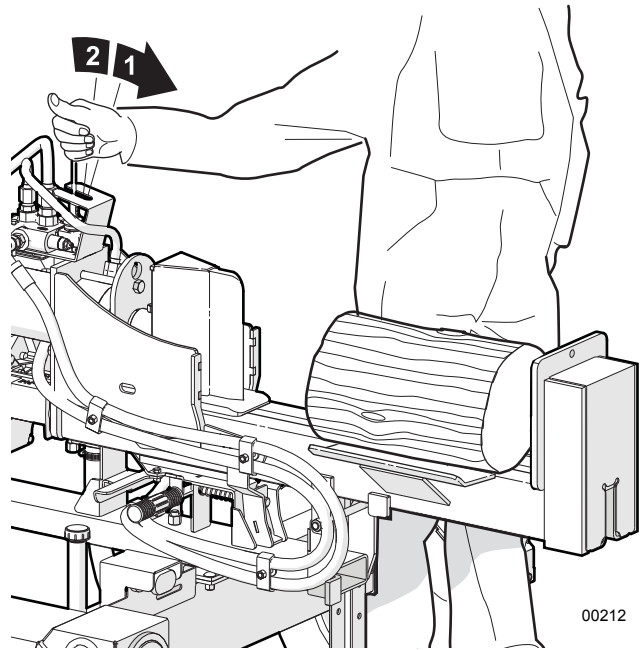

Figure 19—High speed position (2), High power position (1)

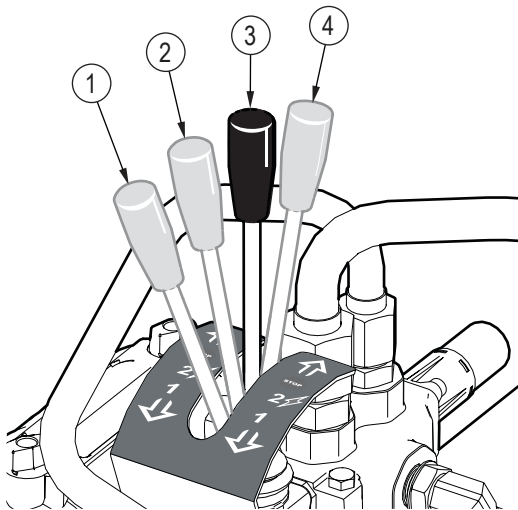

Figure 18—Splitter-control valve

1. High power
2. High speed
3. Stop
4. Retract

6.13.2 Split Wood on an Angle

! WARNING!

Hands can be pinched, cut, crushed, or severed. If two or more people load or operate the machine together, a person can be seriously injured.

Only one person must load and operate the machine.

W036

1. Pull and hold the splitter bed spring latch to release the lock mechanism.
2. Use the handle to turn the splitter bed. The angled position is 20 degrees from the horizontal position.
3. When the splitter bed is in position, release the splitter bed spring latch.
4. Repeat steps 1-7 from *Split Wood Horizontally*.

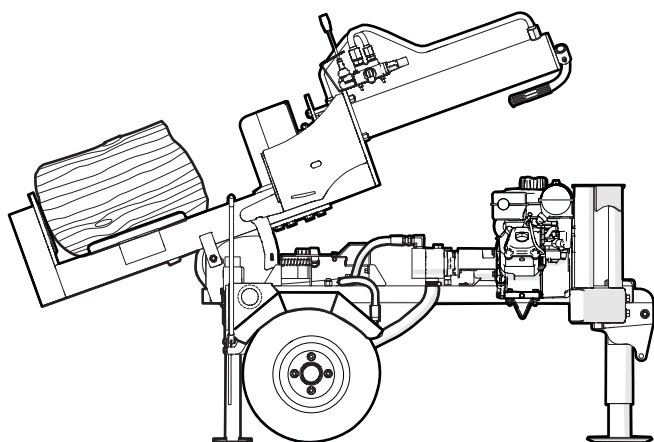

Figure 20—Split wood on an angle

6.13.3 Split Wood Vertically

! WARNING!

Hands can be pinched, cut, crushed, or severed. If two or more people load or operate the machine together, a person can be seriously injured.

Only one person must load and operate the machine.

W036



In the vertical position, the base of the splitter bed lifts the wheels so that the log splitter does not move.

1. Pull and hold the splitter bed spring latch to release the lock mechanism.
2. Use the handle to turn the splitter bed. The vertical position is 90 degrees from the horizontal position.
3. When the splitter bed is in position, release the splitter bed spring latch.
4. Repeat steps 1-7 from *Split Wood Horizontally*.

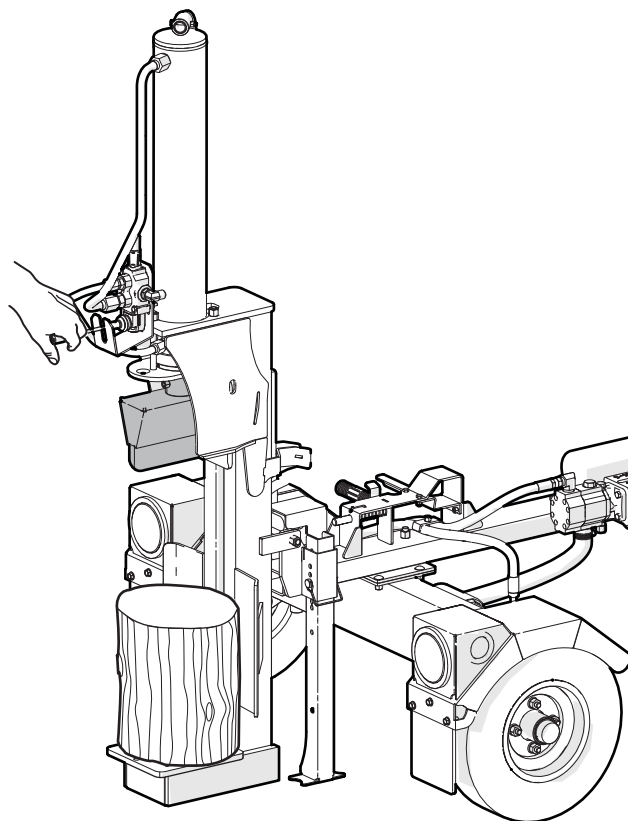

Figure 21—Split wood vertically

7. Transport

7.1 Transport Safety

- Comply with local laws governing safety and transporting of machinery on public roads.
- Do not exceed 50 mph (80 km/h) when towing this machine. Slow down for rough terrain and cornering.
- Do not transport or move the log splitter with the engine running.
- Be sure the trailer is hitched correctly to the towing vehicle and a retainer is used through the hitch mechanism.
- Always attach safety chains between the hitch and the towing vehicle. Cross the chains underneath the trailer tongue.
- Check wheel lugs and tighten if required. Inspect rims for damage.
- Inspect tires for cuts or damage. Check tire pressure and adjust if required.
- Ensure the stability jacks are raised and secured with the latch pin.
- Make sure tow vehicle is fitted with the correct size (2 in) towing ball.
- Make sure fuel and hydraulic tank caps are on tight to prevent spills while transporting.
- Clean all debris off the splitter. Remove any tools or other loose items.
- Check that all the lights, reflectors and other lighting requirements are installed and in good working condition.
- Never allow riders on the machine.
- Be a safe and courteous driver. Always yield to oncoming traffic in all situations, including narrow bridges and intersections.
- Watch for other traffic when near or crossing roadways.
- Do not drink and drive.
- Before transporting, perform an inspection to make sure everything is safe.

7.2 Prepare for Transport

- Make sure the splitter bed is in the horizontal position. The splitter bed spring latch must be locked. For instructions, see *Splitter Bed Spring Latch* on page 21.

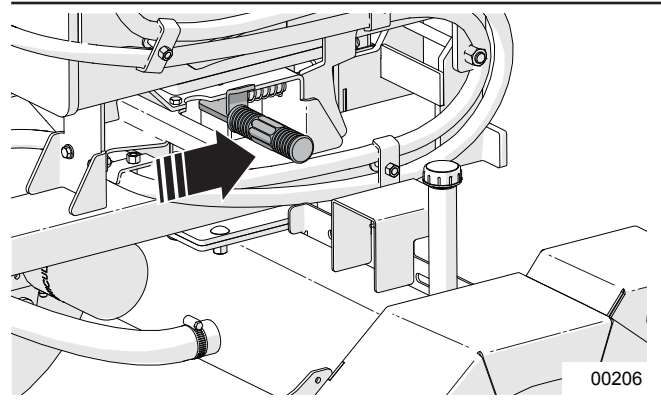

Figure 22—Lock the splitter bed spring latch

- Turn the fuel OFF when transporting.
- Clean all debris from the splitter that could fall off in transport.
- Check tire pressure. Inspect for cuts or damaged rims.
- Check lug nuts and re-torque as necessary. Inspect again after 20–25 mi (32–40 km). Check weekly. See *page 43*.
- Inspect and replace any axle dust caps that are missing, damaged or leaking.
- Always be in compliance with all applicable local regulations when transporting.

7.3 Connect to a Tow Vehicle

1. Keep bystanders clear of the machine.
2. Make sure there is enough room and clearance to safely back up to the machine.
3. Slowly back the tow vehicle until the coupler on the hitch and ball are aligned.

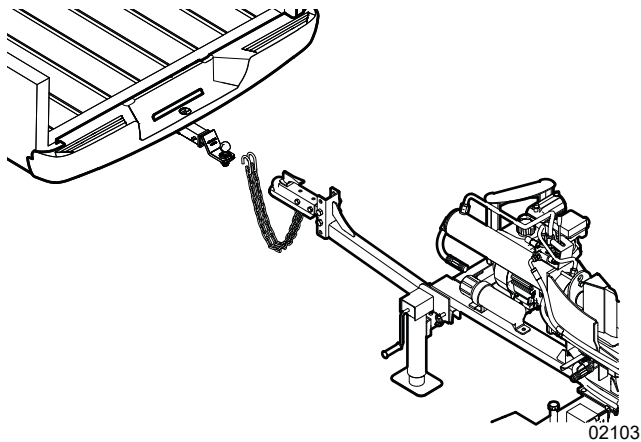

Figure 23—Align the machine with the hitch

4. Lift the hitch and place the coupler over the ball on the hitch.
5. Flip the latch to lock the coupler around the ball.
6. Raise the rear jack stand and secure with the snap lock pin.
7. Cross safety chains under trailer tongue and attach securely to the tow vehicle hitch.
8. Connect the wiring harness for the lights (as equipped).
9. Reverse the above procedure when unhooking.

8. Storage

8.1 Place the Machine in Storage

After the season's use and the log splitter is going to be put away in storage, it should be thoroughly inspected and prepared. Repair or replace any worn or damaged components to prevent any unnecessary down time at the start of next season. The log splitter can have a long, trouble-free life by following these steps:

IMPORTANT! Refer to the engine manufacturer's manual for information specific to engine storage.

1. Fully retract the cylinder ram.
2. Do one of the following:
 - If the machine will be in storage for one to three months, add stabilizer to the engine fuel and drain the carburetor.
 - If the machine will be in storage for longer than three months, replace the engine fuel with an alkylate or appropriate engineered fuel. These fuel types prevent the buildup of insoluble solids (deposits) in the engine. For more information, *Engine Fuel on page 35*. For instructions, see *Replace the Engine Fuel*.
3. Thoroughly wash the machine using a pressure washer to remove all dirt, mud, debris, and residue.
4. Inspect the wedge, cylinder ram, push block and wear plates for damage or entangled material. Repair or replace damaged parts. Remove all entangled material.
5. Touch up all paint nicks and scratches to prevent rusting.
6. Turn the fuel valve off.
7. Store the machine in an area away from human activity.
8. Select an area that is dry, level and free of debris to park the log splitter.
9. If the log splitter is not stored inside a building, cover with a waterproof tarp. Tie securely in place.
10. Do not allow children to play on or around the stored machine.

8.1.1 Replace the Engine Fuel



Before you replace the fuel, read and understand the information under *Engine Safety on page 10*.

1. Remove the current fuel from the engine.
Operate the machine until the fuel tank is empty or drain the fuel tank and properly dispose of the fuel.
2. Add new fuel to the engine.
For instructions, see *Add Fuel to the Engine on page 25*.
3. Start the machine.
For instructions, see *Start the Machine on page 26*.
4. Wait five to 10 minutes for the fuel to flush the carburetor.
5. Stop the machine.
For instructions, see *Stop the Machine on page 27*.

8.2 Remove the Machine from Storage

1. Review and follow the Pre-operation Checklist. See the *Pre-operation Checklist on page 23*
2. Review safety and operation procedures. See *page 7*.

9. Service and Maintenance

WARNING!

Risk of serious personal injury. Stop engine before performing ANY service or maintenance procedure. Reinstall all covers and shields removed before putting machine back into service.

W033

IMPORTANT! Refer to the engine manufacturer's manual for engine maintenance and service information.

9.1 Maintenance Safety

- Follow good shop practices:
 - Keep service area clean and dry.
 - Be sure electrical outlets and tools are properly grounded.
 - Use adequate light for the job at hand.
- Never operate the machine or the towing vehicle in a closed building. The exhaust fumes may cause asphyxiation.
- Before servicing or repairing, place the machine in a **Safe Condition**. See page 9.
- Allow the engine to cool before performing maintenance. Engine components and oil may be hot enough to cause injury.
- Never work under equipment unless it is properly supported.
- When performing any service or maintenance work always use personal protective equipment.
- Where replacement parts are necessary, use only OEM parts to restore your equipment to original specifications. The manufacturer is not responsible for injuries or damages caused by use of unapproved parts or accessories.
- Inspect and tighten all bolts, nuts and screws. Check that all electrical and fuel connections are properly secured.
- When completing a maintenance or service function, make sure all safety shields and devices are installed before placing splitter in service.
- When cleaning any parts, do not use gasoline. Use a cleanser designed for that purpose.
- Always use proper tools in good condition. Make sure you understand how to use them, before performing any service work.



9.2 Fluids and Lubricants

The machine requires various fluids and lubricants for operation and maintenance.

9.2.1 Lubricant Handling and Storage

For optimum machine efficiency, use clean lubricants and clean containers to handle all lubricants. Store lubricants in an area that is protected from dust, moisture, and other contaminants.

9.2.2 Engine Oil

For engine maintenance and service information, see the engine manufacturer's manual.

Briggs & Stratton® Warranty Certified oils are recommended for the best engine performance. However, other high-quality detergent oils are permitted if they are classified for service SF, SG, SH, SJ, or higher. Do not use special additives.

Outdoor temperatures determine the required engine oil viscosity. Select the best oil viscosity for the expected outdoor temperature range. Use the following chart as a guide:

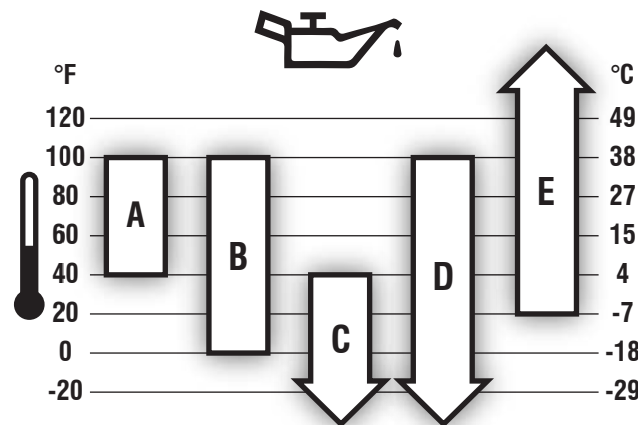

01802

A	SAE 30 – Below 40 °F (4 °C) the use of SAE 30 results in hard starting.
B	10W-30 – Above 80 °F (27 °C) the use of 10W-30 may cause increased oil consumption. Check the oil level frequently.
C	5W-30
D	Synthetic 5W-30
E	Vanguard® Synthetic 15W-50

9.2.3 Engine Fuel

For complete fuel information and use at high altitudes, see the engine manufacturer's manual.

Fuel must meet the following specifications:

- Clean, fresh, unleaded gasoline.
- Minimum of 87 octane / 87 AKI (91 RON).
- Gasoline with up to 10% ethanol (gasohol) is acceptable if the fuel is fresh (less than three months old).

If the machine will be in storage for longer than three months, replace the fuel with one of the following fuel types:

- An alkylate fuel
- An engineered fuel that is high octane, ethanol-free, and formulated with power detergent to prevent the buildup of insoluble solids (deposits).

For instructions, see *Replace the Engine Fuel on page 33*.

Use an SAE multi-purpose high temperature grease with extreme pressure (EP) performance. An SAE multipurpose lithium-based grease is an acceptable substitute.

9.2.4 Hydraulic Fluid

Use Dexron® III automatic transmission fluid (ATF) for all operating conditions.

The following ATFs are acceptable substitutes:

- Dexron VI
- Mercon®

9.3 Maintenance Schedule

IMPORTANT! For more information, see the engine manufacturer's manual.

Complete maintenance tasks at the specified time or hour interval, whichever comes first.

Task	As required	8 hours or daily	40 hours or annually	100 hours or annually	200 hours or annually	Annually	600 hours or every three years	Reference
Check the condition of all hydraulic lines, hoses and fittings.	●							N/A ¹
Remove any entangled material from splitter.	●							N/A
Check that all fasteners are tight.	●							N/A
Check the engine oil level.		●						See page 24
Check the fuel level.		●						See page 25
Clean around the muffler and controls.		●						N/A
Check the hydraulic fluid level.			●					See page 25
Inspect the hydraulic fluid quality.			●					See page 25
Grease the frame slide, hinges, and pivot points.			●					See page 37
Grease the axle bearings.				●				See page 37
Check the tire pressure.				●				See the tire sidewall.
Change the hydraulic fluid and filter.				●				See page 38
Clean the machine.				●				N/A
Service the exhaust system.				●				See the engine manual.
Clean the engine air filter ² .					●			See page 39
Change the engine oil.					●			See the engine manual.
Replace the engine spark plug.						●		See the engine manual.
Service the engine cooling system.						●		See the engine manual.
Service the engine fuel system.						●		See the engine manual.
Change the engine air filter.							●	See page 26

¹ N/A indicates that a reference is not applicable

² In dusty conditions or when airborne debris is present, clean more often.

9.4 Grease Points

Use a hand-held grease gun for all greasing. Pump one shot of grease per fitting.

- Wipe grease fitting with a clean cloth before greasing to avoid injecting dirt and grit.
- If fittings do not take grease, remove and clean them thoroughly. Replace grease fittings as necessary.

Location	Every 40 hours of operation or annually
1	Frame slide

Location	Every 100 hours of operation or annually
2	Axle bearings, one per wheel

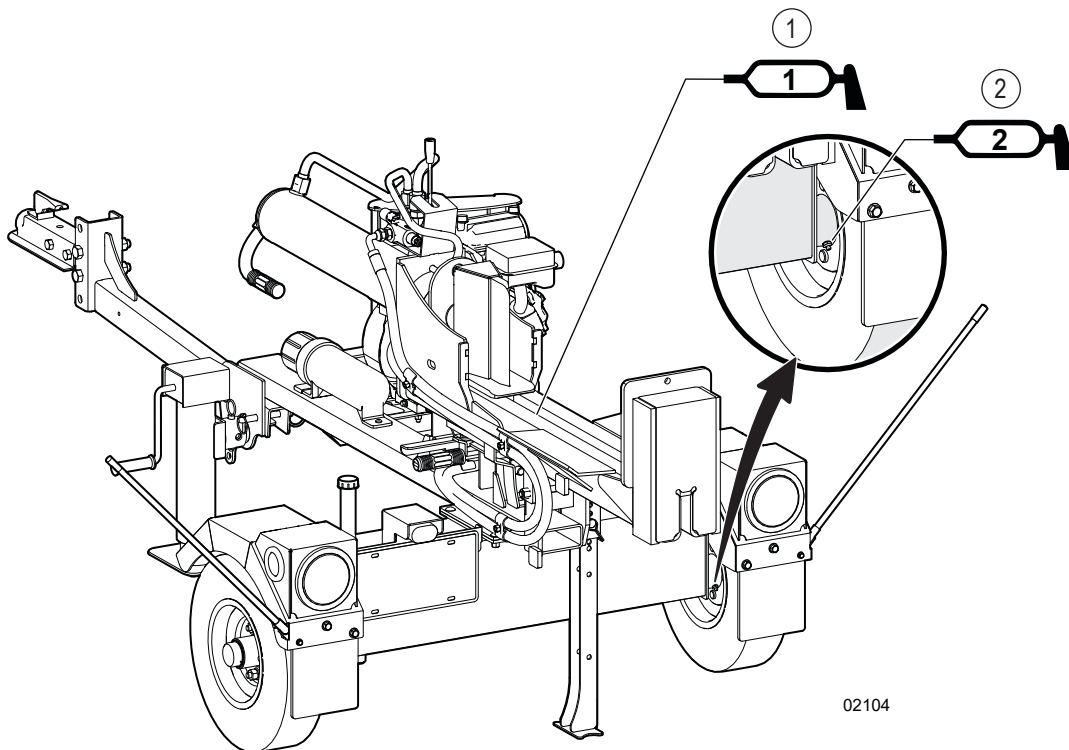

Figure 24—Grease points

9.5 Change the Hydraulic Fluid



Risk of burns to exposed skin. Hydraulic oil becomes hot during operation. Hoses, lines, and other parts become hot as well. Wait for the oil and components to cool before starting any maintenance or inspection work.

W028

Change the hydraulic fluid at 100 hours of operation or annually.

- Hydraulic fluid type: **Dexron® III ATF**
- Hydraulic reservoir volume: **3.9 US gal (15 L)**. An extra 1/2 gal (1–2 liters) may be required to top up the circuit.

There are two hydraulic tank drain plugs located under the machine. Both must be removed to fully drain the tank. Place the machine in a **Safe Condition**. See *page 9*.

A 3/8" hex key is required to remove the drain plugs.



Earlier models had one drain plug.

Procedure

- Place a drain pan of suitable capacity under the drain plugs.
- Clean the area around drains and remove the drain plugs.
- Allow the fluid to fully drain, then flush the tank.
- Dispose of used fluid in an environmentally safe manner.
- Replace the plug and fill the tank with clean fluid, up to the full mark on the dipstick.
- Start the machine up and cycle hydraulic functions to purge air from the system.
- Stop the engine and recheck the fluid level. Top up to the full mark.

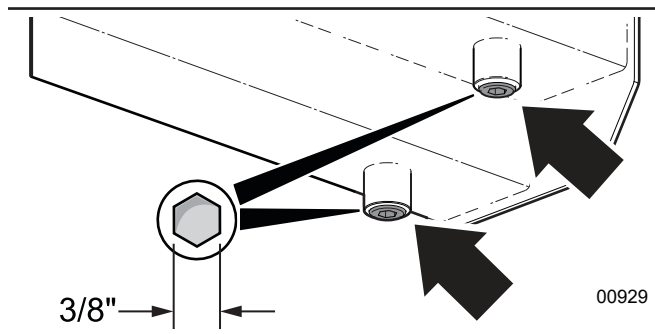

Figure 25—Hydraulic fluid tank drain plugs

9.6 Change the Hydraulic Fluid Filter



Risk of burns to exposed skin. Hydraulic oil becomes hot during operation. Hoses, lines, and other parts become hot as well. Wait for the oil and components to cool before starting any maintenance or inspection work.

W028

Change hydraulic fluid filter at 100 hours of operation or annually.

The filter is located on the side of the hydraulic fluid tank.

Place the machine in a **Safe Condition**. See *page 9*.

Procedure

- Place a drain pan of suitable capacity under the filter head.
- Remove the fluid filter. A fluid filter wrench may be necessary.
- Apply a light coat of clean fluid to the seal and install the new filter. Hand tighten only.
- Run the machine for 1–2 minutes and operate the cylinder. Do an inspection for fluid leaks.
- If a leak is found, shut off the machine and correct it.
- Check hydraulic reservoir fluid level. Top up as required.
- Dispose of spilled fluid in an environmentally safe manner.

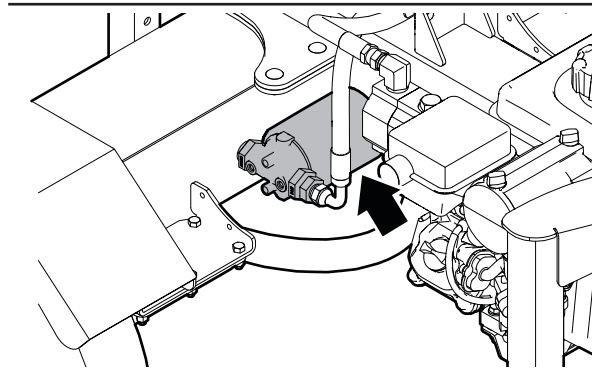

Figure 26—Hydraulic fluid filter

9.7 Engine Air Filter

IMPORTANT! Operating the engine without an air filter, or with a damaged air filter, can allow dirt to enter the engine, causing rapid engine wear. This type of damage is not covered by warranty.

Clean the air filter every 200 hours of operation or annually.

A dirty air filter can restrict air flow to the carburetor, reducing the engine performance. If the engine is operated in very dusty areas, clean the air filter more often than specified.

1. Turn the two air-filter cover fasteners to loosen them.
2. Remove the cover.
3. Remove the air filter.
4. Gently tap the air filter on a hard surface to loosen and remove dust and debris.
If the air filter is excessively dirty or damaged, replace it with a new air filter.
5. Install the air filter in the engine.
6. Install the cover.
7. Tighten the two air-filter cover fasteners.

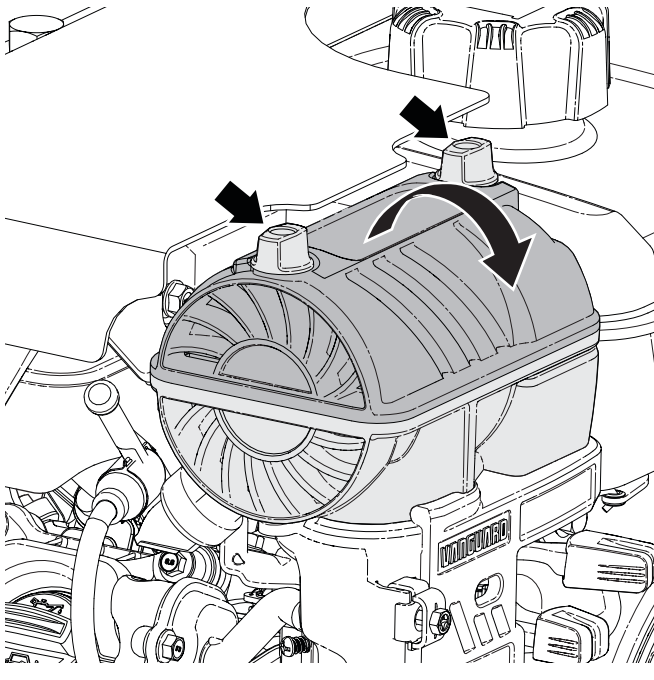

Figure 27 – Engine air filter

10. Troubleshooting

The following table lists some problems that may be encountered, with possible causes and solutions.

If a problem persists after reading through the Troubleshooting section, contact the local dealer, distributor or Wallenstein Equipment. Have the machine serial number ready.

Problem	Cause	Solution
The engine is difficult to start or the performance is reduced.	The engine fuel. Not all fuel is the same.	Change the fuel provider or brand.
The cylinder rod moves slowly or does not move. There is a screeching or hissing noise.	There is no hydraulic fluid pressure.	The hydraulic fluid filter is plugged. Change the filter. Low hydraulic fluid level. Add fluid.
	Wood is jammed around wedge.	The system relief pressure setting is too low. Call your local Wallenstein dealer or distributor. Shut off the machine and safely remove the wood.
	Low engine speed.	Check that the throttle is set to maximum. Check that the choke is off.
The splitter-control handle does not go to neutral after the rod is fully retracted.	The valve detent is set too tight.	Adjustment is necessary to the detent on the splitter control.
	The hydraulic fluid is cold.	Allow the machine to warm up.
	The hydraulic fluid is contaminated.	Change the hydraulic fluid and filter.
The splitter-control handle goes to neutral before the rod is fully retracted.	The detent is set too loose.	Adjustment is necessary to the detent on the splitter control.
Splitter-control handle does not go to neutral when released.	The splitter control may be damaged.	The splitter control may need service or replacement. Call your local Wallenstein dealer or distributor.
The cylinder stops on contact with wood.	The second stage on the pump is not functioning.	The pump may need service or replacement. Call your local Wallenstein dealer or distributor.
The wedge or push block jumps.	The wedge or push block frame is jamming.	Lubricate the slider wear plates.
A hydraulic hose is leaking.	The hose is worn or damaged.	Replace the hose.
The cylinder is leaking.	The seals are worn.	Seal replacement may be necessary. Call your local Wallenstein dealer or distributor.

11. Specifications

For engine specifications, see the engine manufacturer's manual.

For available accessories, go to WallensteinEquipment.com.

11.1 Machine Specifications¹

Model	WXR545PL
Mounting	Trailer mounted
Engine make and horsepower (displacement)	Vanguard® 6.5 hp (203 cc)
Cylinder diameter	4.0 " (101.6 mm)
Cylinder stroke	24" (610 mm)
Splitting force	22 ton
Valve type	Four position, spring-loaded to neutral
Hydraulic pump type	Two stage
Hydraulic pump flow	11 gpm (42 Lpm)
Bed height	24" (61 cm)
Wedge height	9" (23 cm)
Tire size	4.80-8 LRB SportTrail 4on4
Tire type	Highway
Safety chains	Standard
Ball hitch size	2.0"
Splitter Orientation	Horizontal / vertical / angled
Average cycle time	5 seconds
Full cycle time	10.3 seconds
Weight	625 lb (283 kg)
Dimensions (L x W x H)	108 x 49 x 45 in
	274 x 124 x 114 cm

¹ Specifications subject to change without notice.

11.2 Bolt Torque

IMPORTANT! If you replace hardware, use fasteners of the same grade.

IMPORTANT! The torque specifications in these tables are for non-greased or non-oiled threads. Do not grease or oil fastener threads unless otherwise indicated. When using a thread lock, increase the specified torque 5%.



Bolt grades are identified by the marks on top of the bolt head.

These bolt torque specification tables provide the correct torque settings for common bolts and capscrews. Tighten all bolts to the torque that is specified in the table, unless otherwise indicated. Check the bolt tightness periodically.

Imperial Bolt Torque Specifications						
Bolt Diameter	Torque					
	SAE Gr. 2		SAE Gr. 5		SAE Gr. 8	
	lbf•ft	N•m	lbf•ft	N•m	lbf•ft	N•m
1/4 inch	6	8	9	12	12	17
5/16 inch	10	13	19	25	27	36
3/8 inch	20	27	33	45	45	63
7/16 inch	30	41	53	72	75	100
1/2 inch	45	61	80	110	115	155
9/16 inch	60	95	115	155	165	220
5/8 inch	95	128	160	215	220	305
3/4 inch	165	225	290	390	400	540
7/8 inch	170	230	420	570	650	880



SAE Gr. 2



SAE Gr. 5



SAE Gr. 8

Metric Bolt Torque Specifications				
Bolt Diameter	Torque			
	Gr. 8.8		Gr. 10.9	
	lbf•ft	N•m	lbf•ft	N•m
M3	0.4	0.5	1.3	1.8
M4	2.2	3	3.3	4.5
M6	7	10	11	15
M8	18	25	26	35
M10	37	50	52	70
M12	66	90	92	125
M14	83	112	116	158
M16	166	225	229	310
M20	321	435	450	610
M30	1,103	1,495	1,550	2,100



8.8



10.9

11.3 Hydraulic Fitting Torque

Tighten flare-type tube fittings:

1. Check the flare and flare seat for defects that might cause leaks.
2. Align the tube with the fitting before tightening.
3. Hand-tighten the swivel nut until it is snug.
4. To prevent the tube from twisting, use two wrenches. Place one wrench on the connector body and tighten the swivel nut with the second wrench. Torque the fitting to the correct specification.

If a torque wrench is not available, use the flats from finger tight (FFFT) method.

Hydraulic Fitting Torque Specifications					
Tube size OD	Hex size across flats	Torque		Flats from finger tight	
		lbf•ft	N•m	Flats	Turns
3/16	7/16	6	8	2	1/6
1/4	9/16	11–12	15–17	2	1/6
5/16	5/8	14–16	19–22	2	1/6
3/8	11/16	20–22	27–30	1-1/4	1/6
1/2	7/8	44–48	59–65	1	1/6
5/8	1	50–58	68–79	1	1/6
3/4	1-1/4	79–88	107–119	1	1/8
1	1-5/8	117–125	158–170	1	1/8

Specifications are for non-lubricated connections.

11.4 Lug Nut Torque



WARNING!

Wheel lug nuts must be installed and kept at the correct torque to prevent loose wheels, broken studs, or possible separation of a wheel from the axle.

It is an extremely important safety procedure to apply and maintain the correct torque on lug nuts that secure the wheel to the trailer axle. A calibrated torque wrench is the best tool to make sure that the correct amount of torque is applied to a fastener.

Tighten wheel lug nuts to the correct torque before the first use and after each wheel removal. After a wheel is installed, check and torque the lug nuts after the first 10 miles (16 km), 25 miles (40 km), and 50 miles (80 km). Check the lug nut torque periodically thereafter.

- Start all lug nuts onto the threads by hand.
- Tighten lug nuts in stages, following the pattern shown below the Lug Nut Torque Specifications table.

Lug Nut Torque Specifications				
Wheel size	Units	First stage	Second stage	Third stage
8 inch	lbf•ft N•m	12–20 16–26	30–35 39–45.5	45–55 58.5–71.5
12 inch	lbf•ft N•m	20–25 26–32.5	35–40 45.5–52	50–60 65–78
13 inch	lbf•ft N•m	20–25 26–32.5	35–40 45.5–52	50–60 65–78
14 inch	lbf•ft N•m	20–25 26–32.5	50–60 65–78	90–120 117–156
15 inch	lbf•ft N•m	20–25 26–32.5	50–60 65–78	90–120 117–156
16 inch	lbf•ft N•m	20–25 26–32.5	50–60 65–78	90–120 117–156

Lug nut torque pattern:

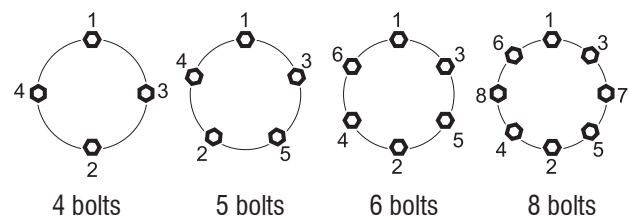

12. Warranty



LIMITED WARRANTY

Wallenstein products are warranted to be free of defects in materials and workmanship under normal use and service, for a period of

Five Years for Consumer Use

Two Years for Commercial/Rental Use

from the date of purchase, when operated and maintained in accordance with the operating and maintenance instructions supplied with the unit. Warranty is limited to the repair of the product and/or replacement of parts.

This warranty is extended only to the original purchaser and is not transferable.

Repairs must be done by an authorized dealer. Products will be returned to the dealer at the customer's expense. Include the original purchase receipt with any claim.

This warranty does not cover the following:

- 1) Normal maintenance or adjustments
- 2) Normal replacement of wearable and service parts
- 3) Consequential damage, indirect damage, or loss of profits
- 4) Damages resulting from:
 - Misuse, negligence, accident, theft or fire
 - Use of improper or insufficient fuel, fluids or lubricants
 - Use of parts or aftermarket accessories other than genuine Wallenstein parts
 - Modifications, alteration, tampering or improper repair performed by parties other than an authorized dealer
 - Any device or accessories installed by parties other than an authorized dealer
- 5) Engines. Engines are covered by the manufacturer of the engine for the warranty period they specify. For the details of your engine warranty, see your engine owner's manual. Information about engine warranty and service is also available in the FAQ section at www.wallensteinequipment.com

13. Index

A		Fuel Level - Checking 24
Add Fuel to the Engine..... 24		
Add Hydraulic Fluid to the Tank 24		
Add Oil to the Engine 23		
Adjust		
Log Splitter Angle..... 28		
Stroke Limiter Adjustment..... 20		
B		
Bolt torque..... 41		
Break-in..... 22		
C		
Checking Bolt Torque 41		
Check the Engine Oil Level..... 23		
Check the Fuel Level 24		
Check the Hydraulic Fluid Level..... 24		
Choke Control 17		
Connecting a Tow Vehicle 31		
Controls..... 17		
Engine Controls 17		
Splitter Control 19		
Stroke Limiter Accessory 20		
D		
Dealer Inspection Checklist..... 4		
Delivery Inspection Report 4		
E		
Emergency Stop..... 26		
Engine		
Add Fuel to the Engine 24		
Add Oil to the Engine..... 23		
Check the Engine Oil Level 23		
Check the Fuel Level..... 24		
Controls 17		
Engine Fuel..... 34		
Engine Air Filter..... 25		
Engine Controls..... 17		
Choke Control..... 17		
Engine Fuel 34		
Engine Oil..... 33		
Engine Safety..... 10		
Equipment Safety Guidelines..... 9		
F		
Familiarization 15		
Job Site Familiarization..... 15		
Machine Components..... 16		
To the New Operator..... 15		
Training..... 15		
Fluid		
Hydraulic..... 34		
Fluids and Lubricants..... 33		
Foreword		
Delivery inspection report 4		
Fuel, engine		
Replace..... 32		
Shutoff 17		
Specifications..... 34		
G		
Grease Points 36		
H		
Hydraulic Fitting Torque 42		
Hydraulic Fluid 34		
Add Hydraulic Fluid..... 24		
Change the Hydraulic Fluid 37		
Change the Hydraulic Fluid Filter 37		
Check the Hydraulic Fluid Level 24		
Type..... 34		
Hydraulic Fluid Tank..... 37		
I		
Inspection		
Dealer Inspection Checklist 4		
Introduction 3		
J		
Job Site Familiarization 15		
L		
Log Placement 26		
M		
Machine Components 16		
Machine Set-up 25		
Machine Specifications 40		
Maintenance..... 33		
Maintenance Decals..... 6		
Maintenance Safety 33		
Maintenance Schedule..... 35		
O		
Oil		
Engine..... 33		
Operating Instructions		
Engine Oil Level Check 23		
Stopping the Engine 26		
Operating Safety 21		
Operation		
Emergency stop..... 26		
Starting the Engine 26		
Stop machine..... 26		
P		
Personal Protective Equipment (PPE) 8		
Pre-operation 22		
Product Labels 6		
Product Warranty 43		
Putting Log splitter in Storage		
Removing from Storage..... 32		
R		
Refueling 24		
Refueling Safety..... 9		
Replace engine fuel 32		
Replacing Damaged Safety Signs 14		

S

Safe Condition.....	9
Safety.....	7
Equipment Safety Guidelines.....	9
Gas Motor Safety.....	10
Hydraulic Safety.....	10
Operating Safety.....	21
Personal Protective Equipment (PPE).....	8
Refuelling Safety.....	9
Safety Alert Symbol.....	7
Safety Training.....	9
Signal Words.....	7
Tire Safety.....	9
Transport Safety.....	9
Safety Alert Symbol.....	7
Safety Decals.....	13
Safety Sign Explanations.....	14
Safety Sign Locations.....	13
Safety Signs.....	13
Replacing Damaged Safety Signs.....	14
Safety Training.....	9
Serial Number Location.....	5
Service and Maintenance.....	33
Change the Hydraulic Fluid.....	37
Change the Hydraulic Fluid Filter.....	37
Electrical System.....	38
Engine Air Filter.....	38
Grease Points.....	36
Maintenance Schedule.....	35
Specifications.....	40
Splitter Control.....	19
Splitter Operation.....	
Machine Break-In.....	22
Operating Instructions.....	21
Pre-operation Checklist.....	22
Split Wood.....	27
Split Wood Horizontally.....	27
Split Wood on an Angle.....	28
Split Wood Vertically.....	29
Storage.....	
Place the Machine in Storage.....	32
Remove the Machine from Storage.....	32
Replace the Engine Fuel.....	32
Stroke Limiter Accessory.....	20

T

Throttle control, engine.....	17
Transport.....	30
Connect to a Tow Vehicle.....	31
Prepare for Transport.....	30
Transport Safety.....	30
Troubleshooting.....	39
Troubleshooting Guide.....	39

W

Warranty.....	43
Wheel Lug Torque.....	42



MAKING WORK FEEL MORE LIKE PLAY™

WallensteinEquipment.com

