

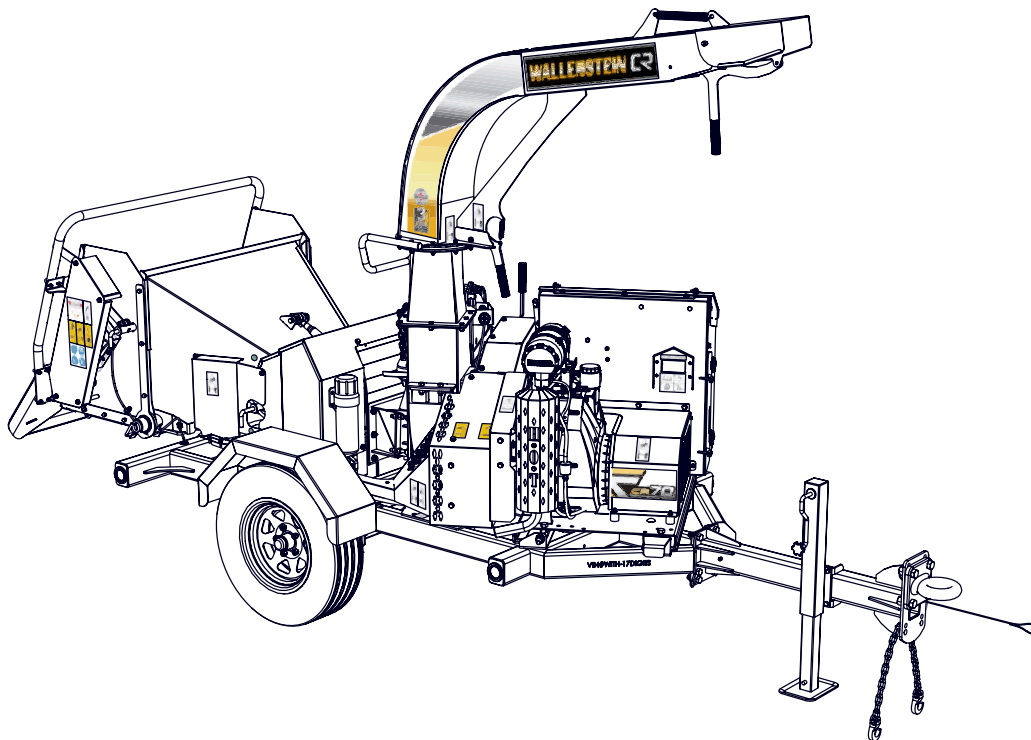

EMB Manufacturing Inc.
4144 Boomer Line · St. Clements, On · N0B 2M0 · Canada
Ph: (519) 699-9283 · Fax: (519) 699-4146
www.wallensteincr.com

CR70 / CR70B Trailer Chipper Parts Manual

Starting with S/N 2E9US1112FS010013



Refer to the operators
manual for safe
operation and
maintenance

Table of Contents

Bolt Torque.....	4	Rotor Housing Rear	18
Hydraulic Fitting Torque	5	Rotor Interlock Latch	19
Wheel Lug Torque	5	Rotor Interlock Clutch	19
Frame Detail - Tongue & Jack.....	6	Rotor Assembly	20
Frame Detail - Front.....	7	Pulley Shroud	21
Frame Detail - Rear	8	Hopper Top / Back View.....	22
Frame & Fender Assembly.....	9	Hopper Front/ Bottom View	23
Hub Assembly.....	10	Upper Roller Right Pivot Arm.....	24
Brake Assembly	10	Upper Roller Left Pivot Arm	24
Engine Carriage.....	11	Upper Roller Assembly	25
Engine	12	Lower Roller Assembly	25
Engine Oil Drain Assembly	12	Hopper Roller Shrouding	26
Engine Parts.....	12	Feed Table	27
Hydraulic Pump Assembly	13	Feed Roller Control Detail.....	28
Fluid Coupler Assembly - Transfluid.....	13	Intellifeed Wiring Harness &	29
Pump Gasket Kit	13	Lights and Brakes Wiring Harness	29
Fluid Coupler Assembly - Rotofluid.....	14	Intellifeed Wiring Diagram #Z62125	30
Tank Compartment	14	Hydraulic Hose Parts List	31
Fuel & Hydraulic Tanks	15	Hydraulic Schematic	32
Hydraulic Tank Rear Detail	16	Label Layout - List	33
Tank Compartment Shroud	16	Label Layout - Left Side.....	34
Discharge Chute	17	Label Layout - Right Side	35
Rotor Housing Front	17	Label Layout	36
		Accessories.....	37

Foreword

EMB Mfg. has prepared this parts manual to assist customers in ordering quality OEM replacement parts.

Proper and regular service and replacing old, worn or broken parts with the correct OEM parts are essential to prolonging the life of your EMB product. Please refer to this manual before ordering any replacement parts.

All information contained in this parts manual is based on the latest product specification available at the time of printing this manual. If your product differs from the specifications contained within this manual contact EMB Mfg. for information.

EMB reserves the right to alter specifications on their products at any time.

Reproduction of this parts manual of any kind is prohibited without prior written permission from EMB Mfg.

For parts and information please contact your dealer. If your dealer is no longer available please go to our website: <http://www.wallensteinequipment.com> and click on "FIND A DEALER NEAR YOU" for information on a local dealer.

Bolt Torque

CHECKING BOLT TORQUE

The tables shown below give correct torque values for various bolts and capscrews. Tighten all bolts to the torques specified in chart unless otherwise noted. Check tightness of bolts periodically, using bolt torque chart as a guide. Replace hardware with the same strength bolt.

ENGLISH TORQUE SPECIFICATIONS						
Bolt Diameter "A"	Bolt Torque*					
	SAE 2 (N.m) (lb-ft)		SAE 5 (N.m) (lb-ft)		SAE 8 (N.m) (lb-ft)	
1/4"	8	6	12	9	17	12
5/16"	13	10	25	19	36	27
3/8"	27	20	45	33	63	45
7/16"	41	30	72	53	100	75
1/2"	61	45	110	80	155	115
9/16"	95	60	155	115	220	165
5/8"	128	95	215	160	305	220
3/4"	225	165	390	290	540	400
7/8"	230	170	570	420	880	650
1"	345	225	850	630	1320	970

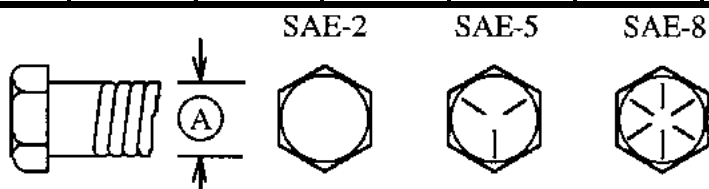

Torque figures indicated above are valid for non-greased or non-oiled threads and heads unless otherwise specified. Therefore, do not grease or oil bolts or capscrews unless otherwise specified in this manual. When using locking elements, increase torque values by 5%.

* Torque value for bolts and capscrews are identified by their head markings.

METRIC TORQUE SPECIFICATIONS				
Bolt Diameter "A"	Bolt Torque*			
	8.8 (N.m) (lb-ft)		10.9 (N.m) (lb-ft)	
M3	0.5	0.4	1.8	1.3
M4	3	2.2	4.5	3.3
M5	6	4	9	7
M6	10	7	15	11
M8	25	18	35	26
M10	50	37	70	52
M12	90	66	125	92
M14	140	103	200	148
M16	225	166	310	229
M20	435	321	610	450
M24	750	553	1050	774
M30	1495	1103	2100	1550
M36	2600	1917	3675	2710

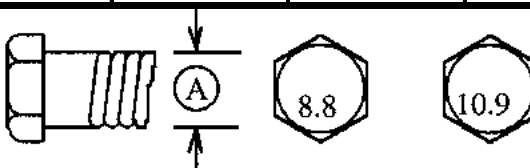

Hydraulic Fitting Torque

Tightening Flare Type Tube Fittings *

1. Check flare and flare seat for defects that might cause leakage.
2. Align tube with fitting before tightening.
3. Lubricate connection and hand tighten swivel nut until snug.
4. To prevent twisting the tube(s), use two wrenches. Place one wrench on the connector body and with the second tighten the swivel nut to the torque shown.

Tube Size OD (in.)	Nut Size Across Flats (in.)	Torque Value*		Recommended Turns To Tighten (After Finger Tightening)	
		(N.m)	(lb-ft)	(Flats)	(Turn)
3/16	7/16	8	6	1	1/6
1/4	9/16	12	9	1	1/6
5/16	5/8	16	12	1	1/6
3/8	11/16	24	18	1	1/6
1/2	7/8	46	34	1	1/6
5/8	1	62	46	1	1/6
3/4	1-1/4	102	75	3/4	1/8
7/8	1-3/8	122	90	3/4	1/8

The torque values shown are based on lubricated connections as in reassembly.

Wheel Lug Torque

It is extremely important safety procedure to apply and maintain proper wheel mounting torque on your trailer axle. Torque wrenches are the best method to assure the proper amount of torque is being applied to a fastener.

Wheel lugs should be torqued before first road use and after each wheel removal. Check and re torque after the first 16Km (10 miles), 40Km (25 miles), and again at 80Km (50 miles). Check periodically thereafter.

Note: Wheel lugs must be applied and maintained at the proper torque levels to prevent loose wheels, broken studs, and possible dangerous separation of wheels from your axle.

- Start all lugs by hand to prevent cross threading.
- Tighten lugs in sequence, per wheel lug torque sequence chart.
- The tightening of the fasteners should be done in stages. Following the recommended sequence, tighten fasteners per wheel torque requirements chart.

Wheel Torque Requirements				
Wheel Size	Torque Unit	1st Stage	2nd Stage	3rd Stage
8"	ft-lbs	12 - 20	30 - 35	45 - 55
	Nm	16 - 26	39 - 45.5	58.5 - 71.5
12"	ft-lbs	20 - 25	35 - 40	50 - 60
	Nm	26 - 32.5	45.5 - 52	65 - 78
13"	ft-lbs	20 - 25	35 - 40	50 - 60
	Nm	26 - 32.5	45.5 - 52	65 - 78
14"	ft-lbs	20 - 25	50 - 60	90 - 120
	Nm	26 - 32.5	65 - 78	117 - 156
15"	ft-lbs	20 - 25	50 - 60	90 - 120
	Nm	26 - 32.5	65 - 78	117 - 156
16"	ft-lbs	20 - 25	50 - 60	90 - 120
	Nm	26 - 32.5	65 - 78	117 - 156

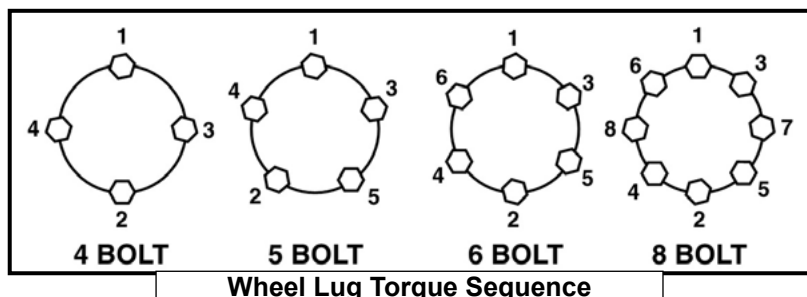

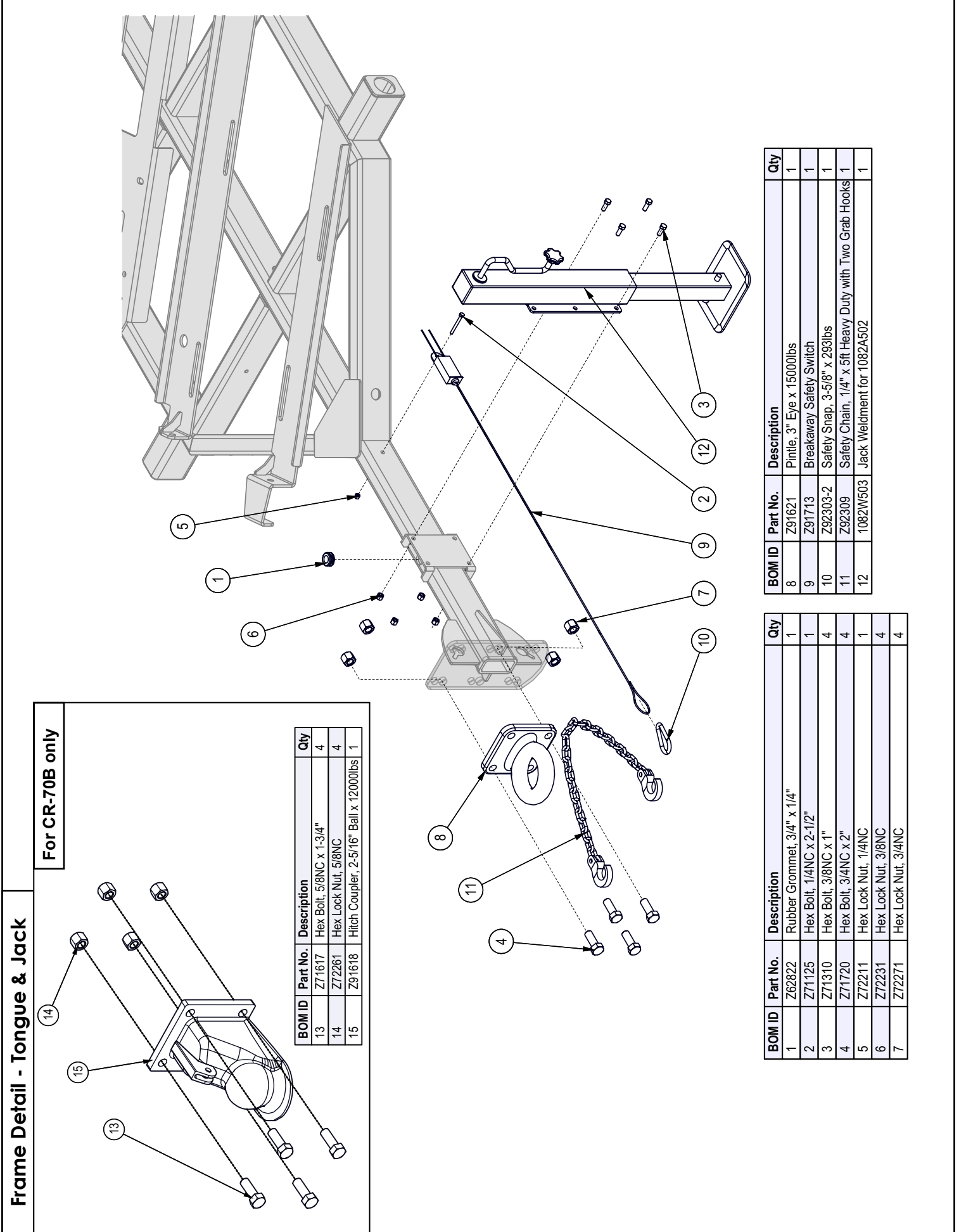

Frame Detail - Tongue & Jack

For CR-70B only

BOM ID	Part No.	Description	Qty
13	Z71617	Hex Bolt, 5/8NC x 1-3/4"	4
14	Z72261	Hex Lock Nut, 5/8NC	4
15	Z91618	Hitch Coupler, 2-5/16" Ball x 12000lbs	1

BOM ID	Part No.	Description	Qty
8	Z91621	Pintle, 3" Eye x 1500lbs	1
9	Z91713	Breakaway Safety Switch	1
10	Z92303-2	Safety Snap, 3-5/8" x 293lbs	1
11	Z92309	Safety Chain, 1/4" x 5ft Heavy Duty with Two Grab Hooks	1
12	1082W503	Jack Weldment for 1082A502	1

BOM ID	Part No.	Description	Qty
1	Z62822	Rubber Grommet, 3/4" x 1/4"	1
2	Z71125	Hex Bolt, 1/4NC x 2-1/2"	1
3	Z71310	Hex Bolt, 3/8NC x 1"	4
4	Z71720	Hex Bolt, 3/4NC x 2"	4
5	Z72211	Hex Lock Nut, 1/4NC	1
6	Z72231	Hex Lock Nut, 3/8NC	4
7	Z72271	Hex Lock Nut, 3/4NC	4

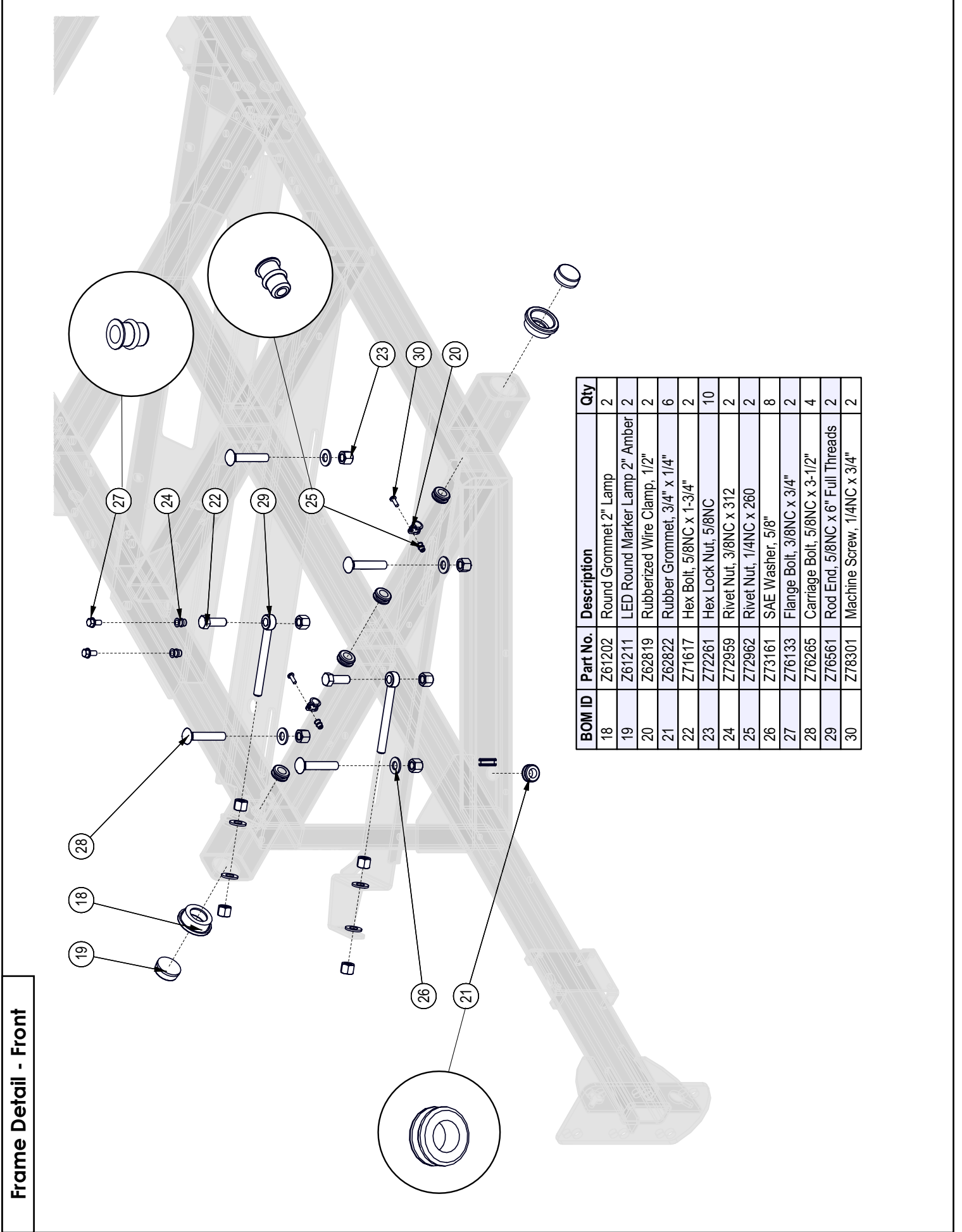

BOM ID	Part No.	Description	Qty
18	Z61202	Round Grommet 2" Lamp	2
19	Z61211	LED Round Marker Lamp 2" Amber	2
20	Z62819	Rubberized Wire Clamp, 1/2"	2
21	Z62822	Rubber Grommet, 3/4" x 1/4"	6
22	Z71617	Hex Bolt, 5/8NC x 1-3/4"	2
23	Z72261	Hex Lock Nut, 5/8NC	10
24	Z72959	Rivet Nut, 3/8NC x 3/2	2
25	Z72962	Rivet Nut, 1/4NC x 260	2
26	Z73161	SAE Washer, 5/8"	8
27	Z76133	Flange Bolt, 3/8NC x 3/4"	2
28	Z76265	Carriage Bolt, 5/8NC x 3-1/2"	4
29	Z76561	Rod End, 5/8NC x 6" Full Threads	2
30	Z78301	Machine Screw, 1/4NC x 3/4"	2

Frame Detail - Front

Frame Detail - Rear

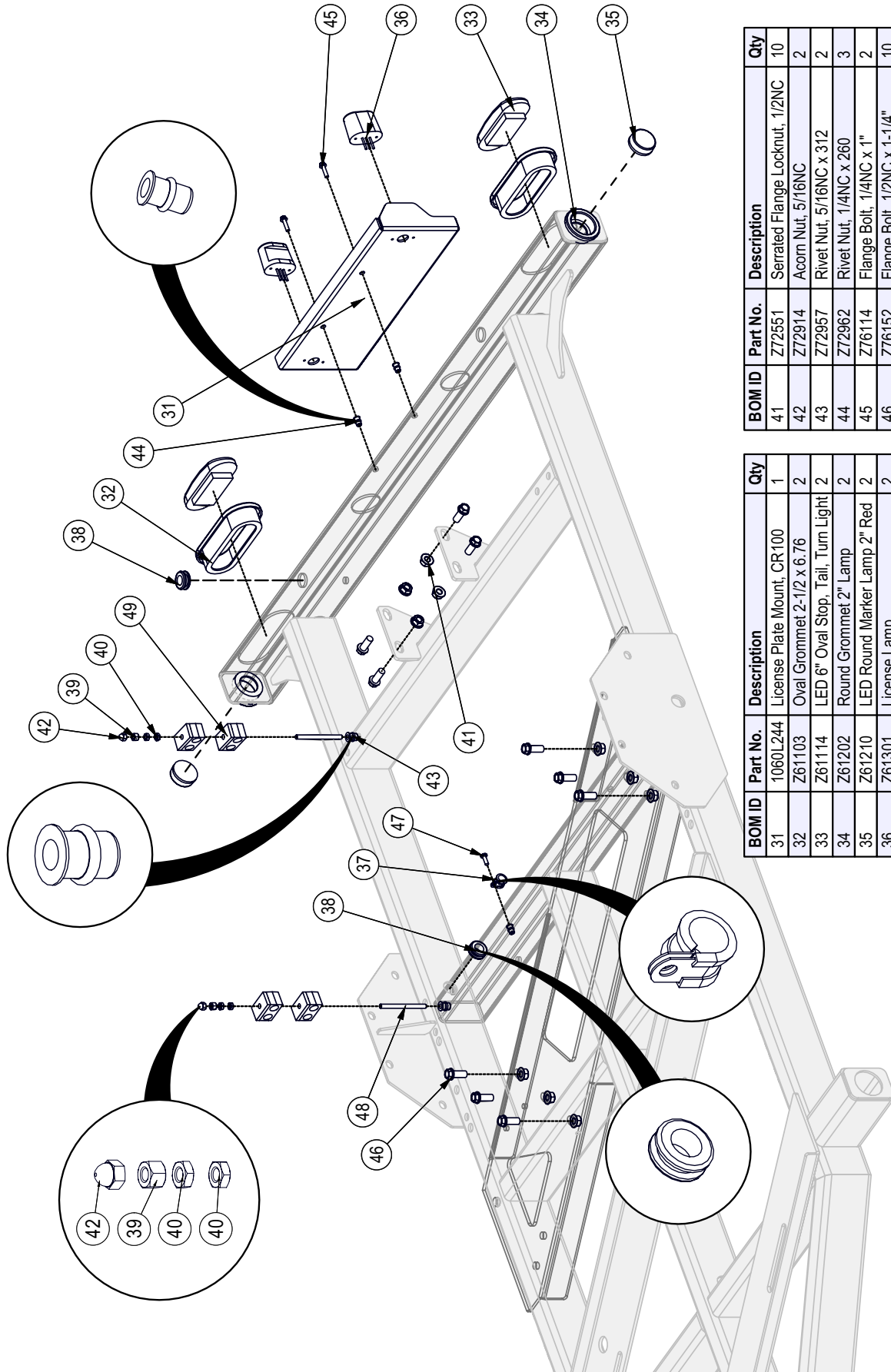

BOM ID	Part No.	Description	Qty
41	Z72551	Serrated Flange Locknut, 1/2NC	10
42	Z72914	Acorn Nut, 5/16NC	2
43	Z72957	Rivet Nut, 5/16NC x 312	2
44	Z72962	Rivet Nut, 1/4NC x 260	3
45	Z76114	Flange Bolt, 1/4NC x 1"	2
46	Z76152	Flange Bolt, 1/2NC x 1-1/4"	10
47	Z78301	Machine Screw, 1/4NC x 3/4"	1
48	Z79141	Threaded Stud, 5/16NC x 4"	2
49	Z79463	Double Hose Clamp, 1 1/16" OD	4

BOM ID	Part No.	Description	Qty
31	1060L244	License Plate Mount, CR100	1
32	Z61103	Oval Grommet 2-1/2 x 6.76	2
33	Z61114	LED 6" Oval Stop, Tail, Turn Light	2
34	Z61202	Round Grommet 2" Lamp	2
35	Z61210	LED Round Marker Lamp 2" Red	2
36	Z61301	License Lamp	2
37	Z62819	Rubberized Wire Clamp, 1/2"	1
38	Z62822	Rubber Grommet 3/4 x 1/4	2
39	Z72221	Hex Lock Nut, 5/16NC	2
40	Z72321	Jam Nut, 5/16NC	4

Frame & Fender Assembly

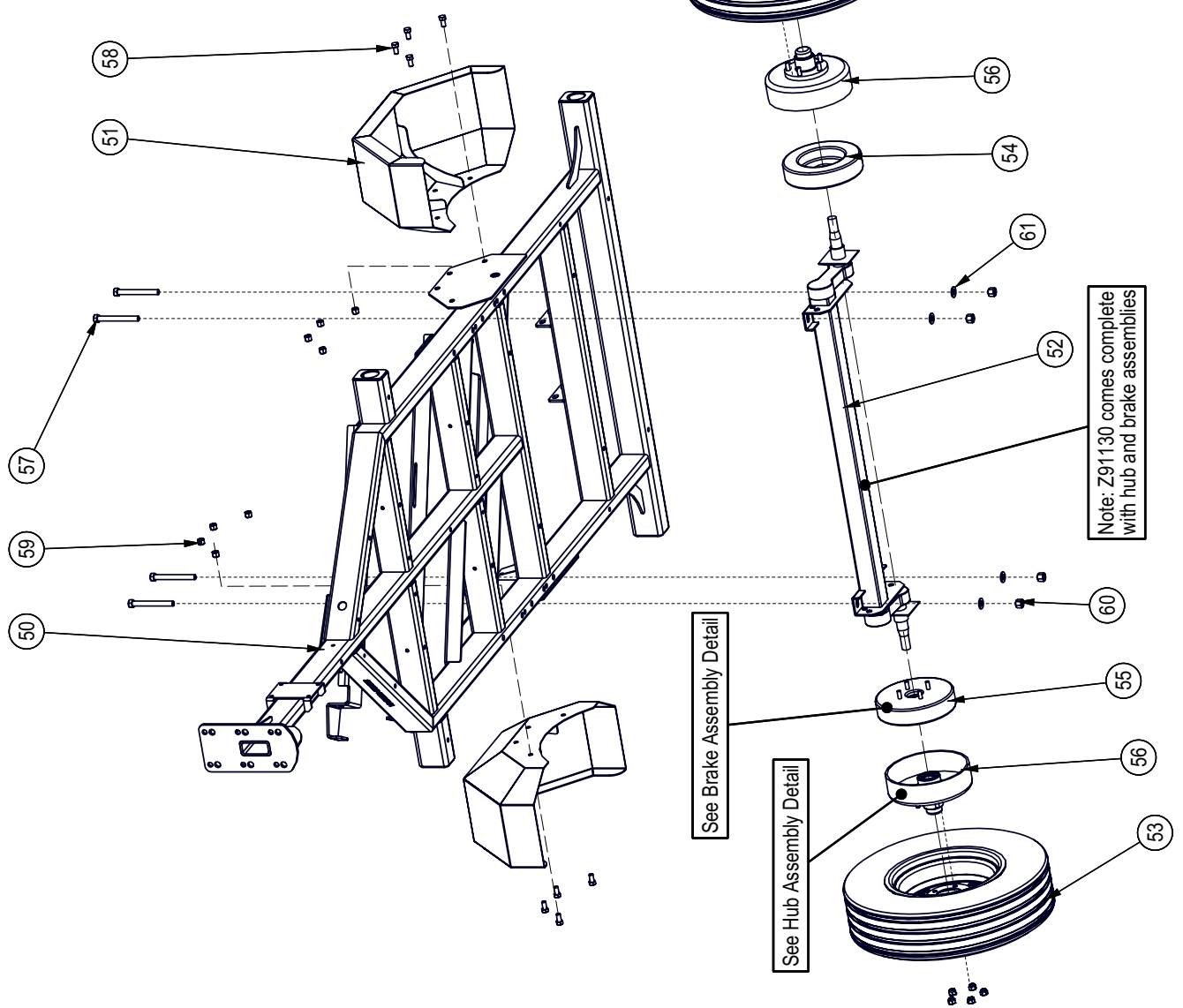

BOM ID	Part No.	Description	Qty
50	1061W169	CR70 Chassis Weldment	1
51	1061W120	Fender Well Weldment	2
52	Z91130	#10 Full Flex Axle, 3500lbs x 56" HF With Electric Brakes	1
53	Z91317	ST205/75R14 LRC Radial Trail 5on4-1/2"	2
54	Z91718	Electric Brake, 10" x 2-1/4" x 1750lbs LH	1
55	Z91719	Electric Brake, 10" x 2-1/4" x 1750lbs RH	1
56	Z91705	Brake Drum, 10" x 1750lbs 5on4-1/2" Complete Assembly	2
57	Z71655	Hex Bolt, 5/8NC x 5-1/2"	4
58	Z71510	Hex Bolt, 1/2NC x 1"	8
59	Z72251	Hex Lock Nut, 1/2NC	8
60	Z72261	Hex Lock Nut, 5/8NC	4
61	Z73161	SAE Washer, 5/8"	4

Hub Assembly

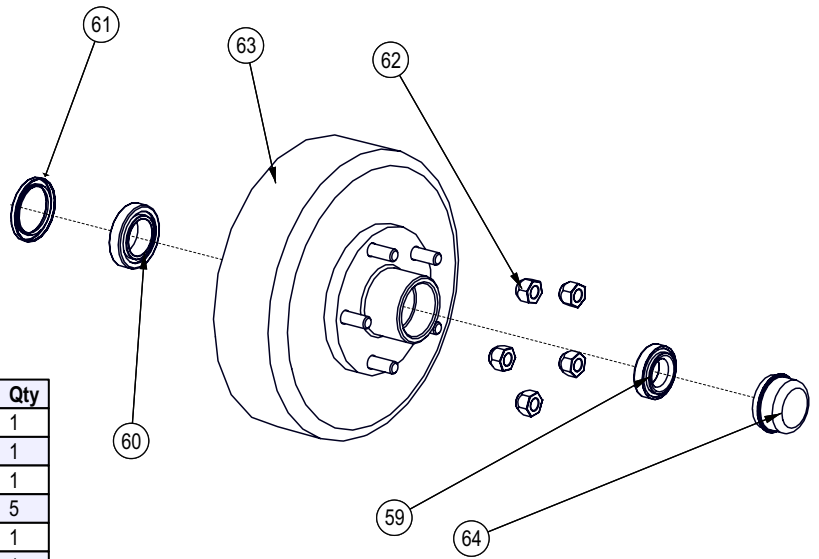
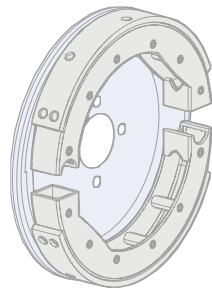
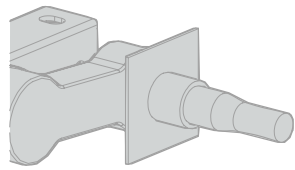

BOM ID	Part No.	Description	Qty
59	Z23202	L44649 Cone, L44610 Cup	1
60	Z23205	L68149 Cone and L68111 Cup	1
61	Z28202	Seal, Single Lip	1
62	Z72931	Lug Nut, 1/2NF	5
63	Z91708	1750# Brake Drum 10" 5 - 4-1/2 Bolts	1
64	Z91801	Dust Cap 1.98 Bore	1

Brake Assembly

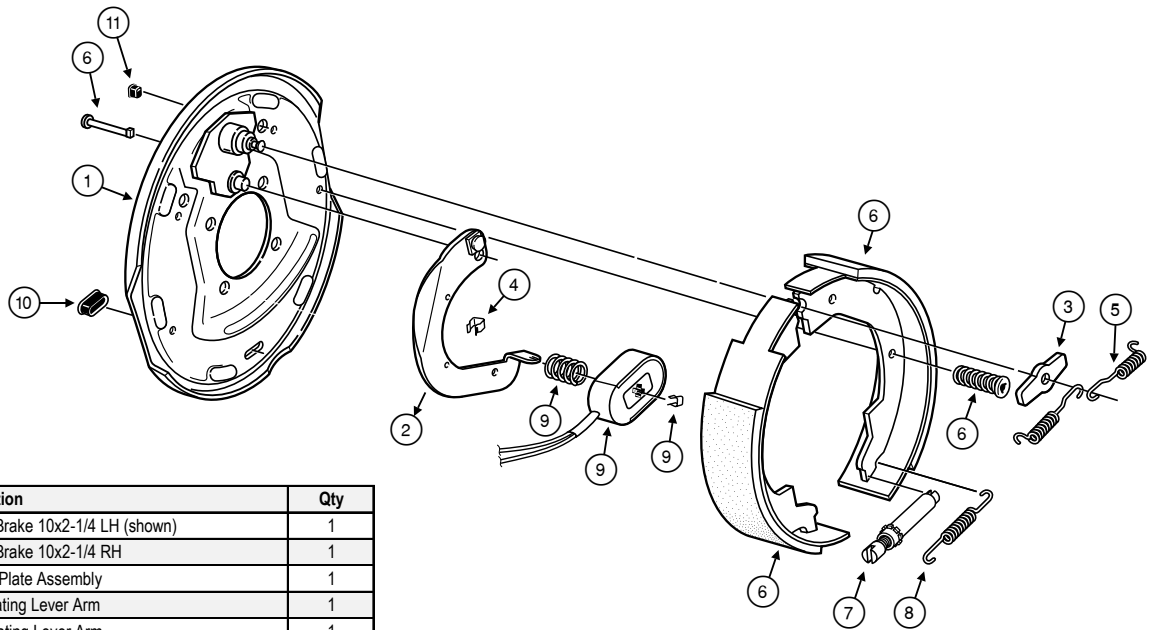

Item	Part No.	Description	Qty
	Z91718	Electric Brake 10x2-1/4 LH (shown)	1
	Z91719	Electric Brake 10x2-1/4 RH	1
1	036-019-10	Backing Plate Assembly	1
2	047-019-05	LH Actuating Lever Arm	1
2	047-020-05	RH Actuating Lever Arm	1
3	005-067-00	Washer	1
4	027-005-00	Wire Clip	2
5	046-009-00	Retractor Spring	2
6	K71-047-00	Shoe & Lining Kit Contains:	1
	#040-017-00	Primary Shoe & Lining	1
	#040-021-00	Secondary Shoe & Lining	1
	#049-002-00	Shoe Hold Down Pin #8	2
	#046-077-00	Shoe Hold Down Spring & Cup	2
7	043-004-00	Adjuster Assembly	1
8	046-018-00	Adjusting Screw Spring	1
9	K71-104-00	Magnet Kit Contains:	1
	#042-140-00	Magnet (green wire)	1
	#027-009-00	Magnet Clip	1
	#046-080-00	Magnet Spring	1
10	046-007-00	Adjuster Slot Plug	2
11	046-016-00	Wire Grommet	1

Please note: brake parts are not available from EMB Mfg. Brake part numbers here reference Dexter Axle brake assemblies and are available from your local auto parts dealer. All brake repair and maintenance should be done by a qualified mechanic.

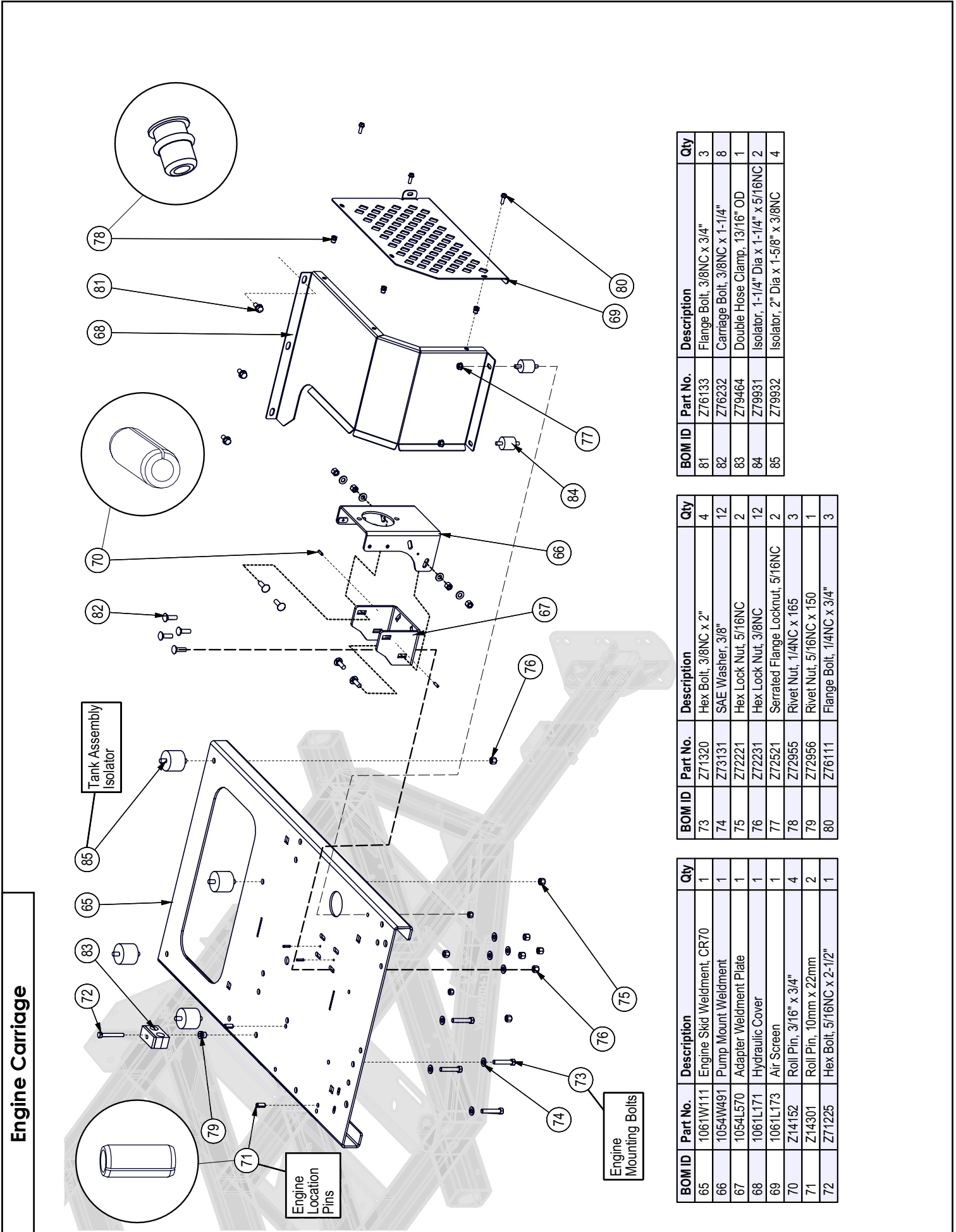

Engine Carriage

BOM ID	Part No.	Description	Qty
81	Z76133	Flange Bolt, 3/8NC x 3/4"	3
82	Z76232	Carriage Bolt, 3/8NC x 1-1/4"	8
83	Z79464	Double Hose Clamp, 13/16" OD	1
84	Z79931	Isolator, 1-1/4" Dia x 1-1/4" x 5/16NC	2
85	Z79932	Isolator, 2" Dia x 1-5/8" x 3/8NC	4

BOM ID	Part No.	Description	Qty
73	Z71320	Hex Bolt, 3/8NC x 2"	4
74	Z73131	SAE Washer, 3/8"	12
75	Z72221	Hex Lock Nut, 5/16NC	2
76	Z72231	Hex Lock Nut, 3/8NC	12
77	Z72521	Serrated Flange Locknut, 5/16NC	2
78	Z72955	Rivet Nut, 1/4NC x 165	3
79	Z72956	Rivet Nut, 5/16NC x 150	1
80	Z76111	Flange Bolt, 1/4NC x 3/4"	3

BOM ID	Part No.	Description	Qty
65	1061W111	Engine Skid Weldment, CR70	1
66	1054W491	Pump Mount Weldment	1
67	1054L570	Adapter Weldment Plate	1
68	1061L171	Hydraulic Cover	1
69	1061L173	Air Screen	1
70	Z14152	Roll Pin, 3/16" x 3/4"	4
71	Z14301	Roll Pin, 10mm x 22mm	2
72	Z71225	Hex Bolt, 5/16NC x 2-1/2"	1

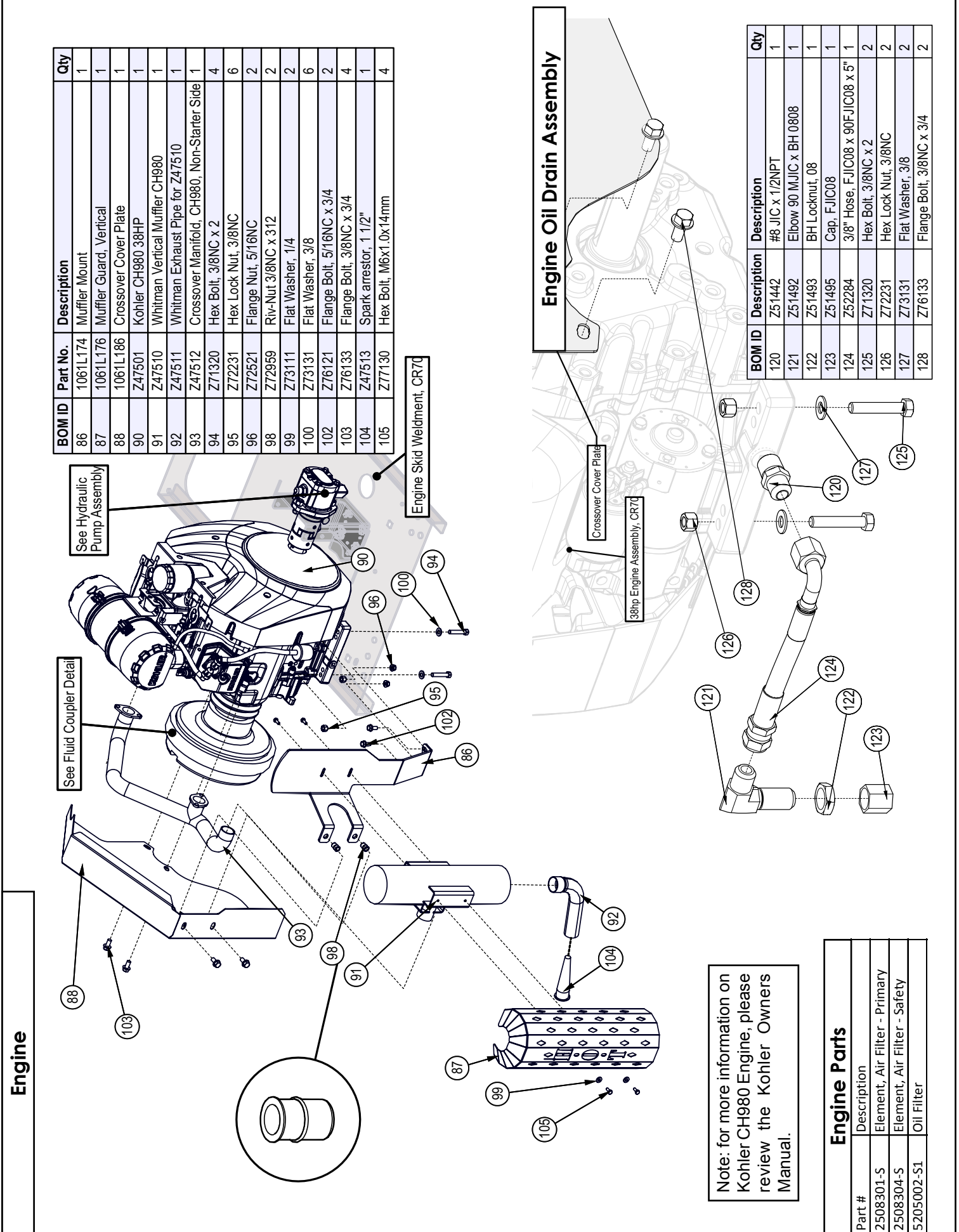

BOM ID	Part No.	Description	Qty
86	1061L174	Muffler Mount	1
87	1061L176	Muffler Guard, Vertical	1
88	1061L186	Crossover Cover Plate	1
90	Z47501	Kohler CH980 38HP	1
91	Z47510	Whitman Vertical Muffler CH980	1
92	Z47511	Whitman Exhaust Pipe for Z47510	1
93	Z47512	Crossover Manifold, CH980, Non-Starter Side	1
94	Z71320	Hex Bolt, 3/8NC x 2	4
95	Z72231	Hex Lock Nut, 3/8NC	6
96	Z72521	Flange Nut, 5/16NC	2
98	Z72959	Riv-Nut 3/8NC x 3/12	2
99	Z73111	Flat Washer, 1/4	2
100	Z73131	Flat Washer, 3/8	6
102	Z76121	Flange Bolt, 5/16NC x 3/4	2
103	Z76133	Flange Bolt, 3/8NC x 3/4	4
104	Z47513	Spark arrestor, 1 1/2"	1
105	Z77130	Hex Bolt, M6x1.0x14mm	4

BOM ID	Description	Description	Qty
120	Z51442	#8 JIC x 1/2NPT	1
121	Z51492	Elbow 90 M/JIC x BH 0808	1
122	Z51493	BH Locknut, 08	1
123	Z51495	Cap. F JIC08	1
124	Z52284	3/8" Hose, F JIC08 x 90F JIC08 x 5"	1
125	Z71320	Hex Bolt, 3/8NC x 2	2
126	Z72231	Hex Lock Nut, 3/8NC	2
127	Z73131	Flat Washer, 3/8	2
128	Z76133	Flange Bolt, 3/8NC x 3/4	2

Note: for more information on Kohler CH980 Engine, please review the Kohler Owners Manual.

Engine Parts	
Part #	Description
2508301-S	Element, Air Filter - Primary
2508304-S	Element, Air Filter - Safety
5205002-51	Oil Filter

Hydraulic Pump Assembly

Pump Gasket Kit	
Part #	Description
SK PL20-S/D-49	Pump Gasket Kit for #148740

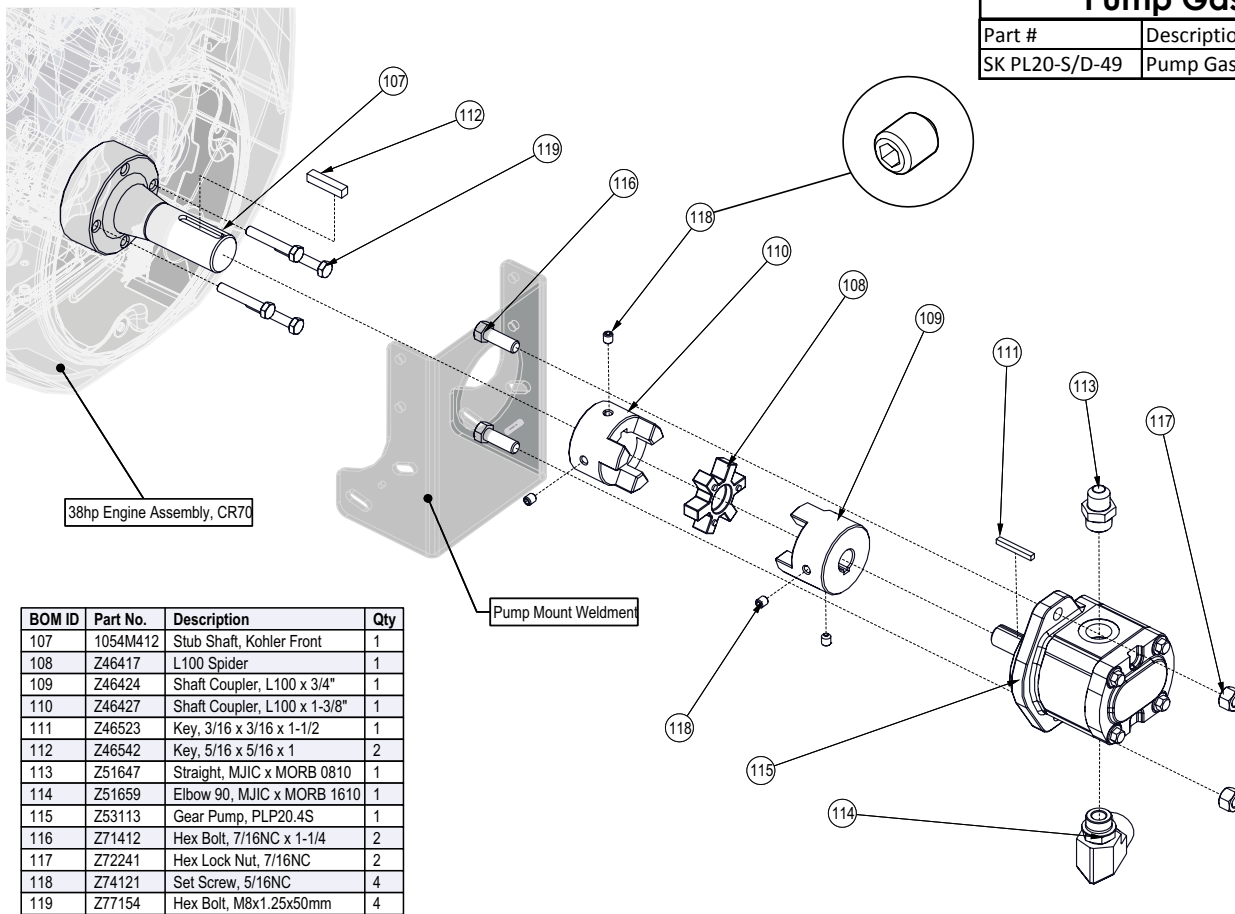

BOM ID	Part No.	Description	Qty
107	1054M412	Stub Shaft, Kohler Front	1
108	Z46417	L100 Spider	1
109	Z46424	Shaft Coupler, L100 x 3/4"	1
110	Z46427	Shaft Coupler, L100 x 1-3/8"	1
111	Z46523	Key, 3/16 x 3/16 x 1-1/2	1
112	Z46542	Key, 5/16 x 5/16 x 1	2
113	Z51647	Straight, MJIC x MORB 0810	1
114	Z51659	Elbow 90, MJIC x MORB 1610	1
115	Z53113	Gear Pump, PLP20.4S	1
116	Z71412	Hex Bolt, 7/16NC x 1-1/4	2
117	Z72241	Hex Lock Nut, 7/16NC	2
118	Z74121	Set Screw, 5/16NC	4
119	Z77154	Hex Bolt, M8x1.25x50mm	4

Fluid Coupler Assembly - Transfluid

Note: Z49303 Transfluid is interchangeable with Z49304 Rotofluid

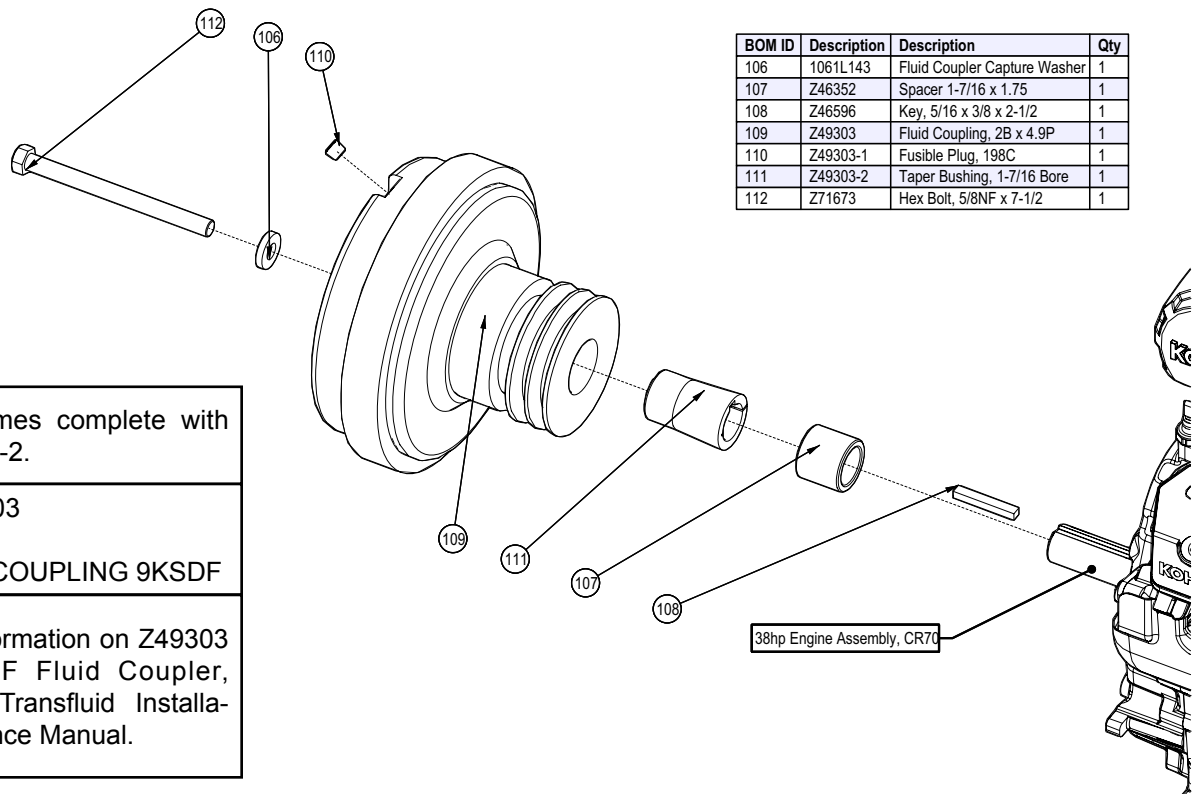

BOM ID	Description	Description	Qty
106	1061L143	Fluid Coupler Capture Washer	1
107	Z46352	Spacer 1-7/16 x 1.75	1
108	Z46596	Key, 5/16 x 3/8 x 2-1/2	1
109	Z49303	Fluid Coupling, 2B x 4.9P	1
110	Z49303-1	Fusible Plug, 198C	1
111	Z49303-2	Taper Bushing, 1-7/16 Bore	1
112	Z71673	Hex Bolt, 5/8NF x 7-1/2	1

Note: Z49303 comes complete with Z94303-1 & Z9303-2.

Seal Kit for #Z49303
#107200000183
SEAL KIT, FLUID COUPLING 9KSDF

Note: for more information on Z49303 Transfluid 9KSDF Fluid Coupler, please review the Transfluid Installation and Maintenance Manual.

Fluid Coupler Assembly - Rotofluid

Note: Z49304 Rotofluid is interchangeable with Z49303 Transfluid

BOM ID	Part No.	Description	Qty
108	Z46596	Key, 5/16 x 3/8 x 2-1/2	1
113	Z49304	Fluid Coupling, 2B x 4.9P	1
114	Z49304-1	RotoFluid Bushing	1
115	Z49304-2	Fuseable Plug 180°	1
116	Z49304-3	Pulley 125mm PD	1
117	Z71674	Hex Bolt, 5/8NF x 6-1/2"	1

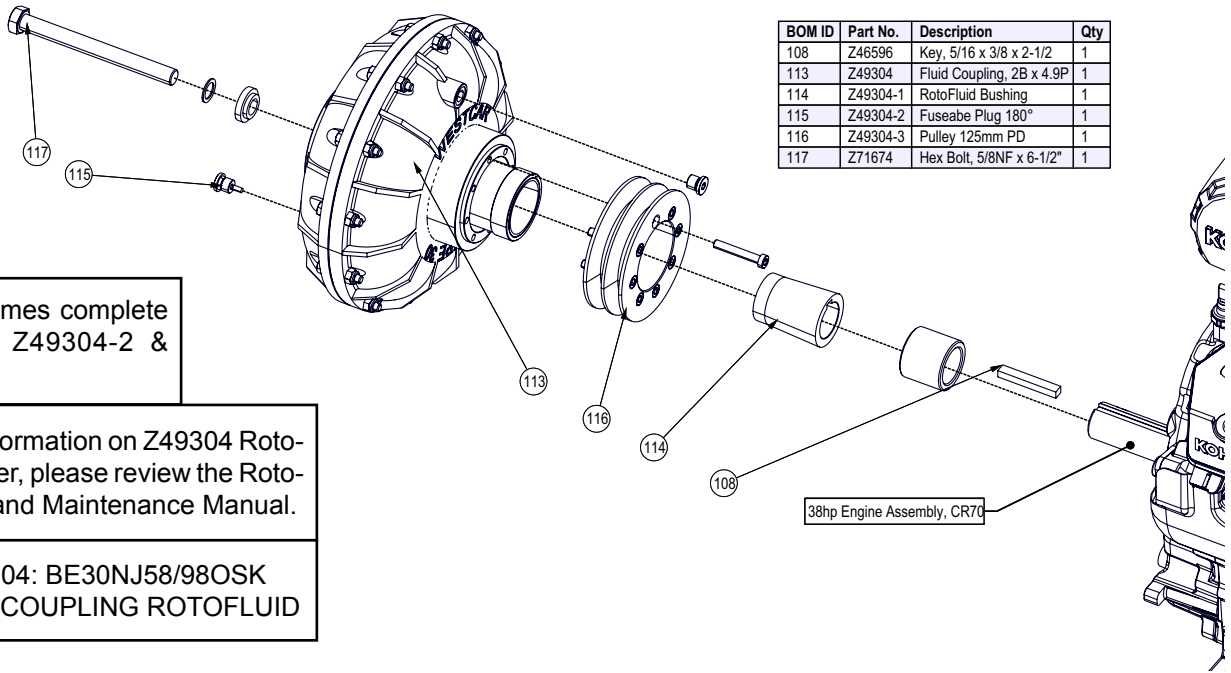

Note: Z49304 comes complete with Z49304-1, Z49304-2 & Z49304-3.

Note: for more information on Z49304 Roto-Fluid Fluid Coupler, please review the Roto-fluid Installation and Maintenance Manual.

Seal Kit for #Z49304: BE30NJ58/98OSK SEAL KIT, FLUID COUPLING ROTOFLUID

Tank Compartment

BOM ID	Description	Description	Qty
129	1061L179	CR70 Toolbox	1
130	1061L216	Battery Cage	1
131	1061W114	Tank Shroud Weldment, CR70	1
132	Z62816	Deutsch Mounting Clip	1
133	Z62819	Rubberized Wire Clamp, 1/2"	1
134	Z62823	Rubber Grommet 3/4 x 1/8	2
135	Z66204	Control, IntelliFEED	1
136	Z71207	Hex Bolt, 5/16NC x 3/4	2
137	Z71307	Hex Bolt, 3/8NC x 3/4	2
138	Z72211	Hex Lock Nut, 1/4NC	3
139	Z72221	Hex Lock Nut, 5/16NC	2
140	Z72231	Hex Lock Nut, 3/8NC	2
141	Z72511	Hex Flange Nut, 1/4NC	3
142	Z72958	Riv-Nut 3/8NC x 150	8
143	Z73111	Flat Washer, 1/4	1
144	Z76211	Carriage Bolt, 1/4NC x 3/4	3
145	Z78301	Machine Screw, 1/4-20NC x 3/4	3
146	Z78302	Machine Screw, #10-32NF x 3/8	4
147	Z93308	EPA Carbon Canister 1200cc	1

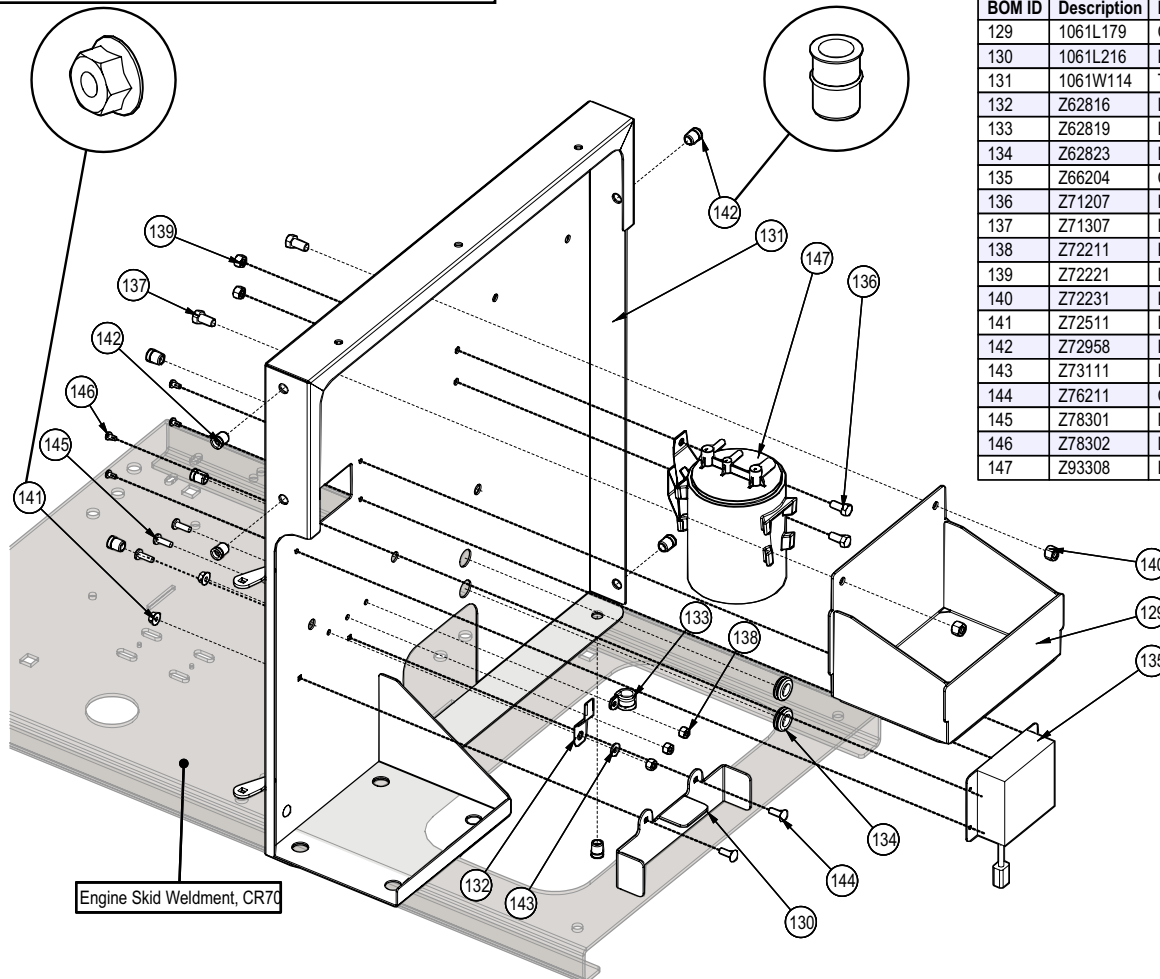

Fuel & Hydraulic Tanks

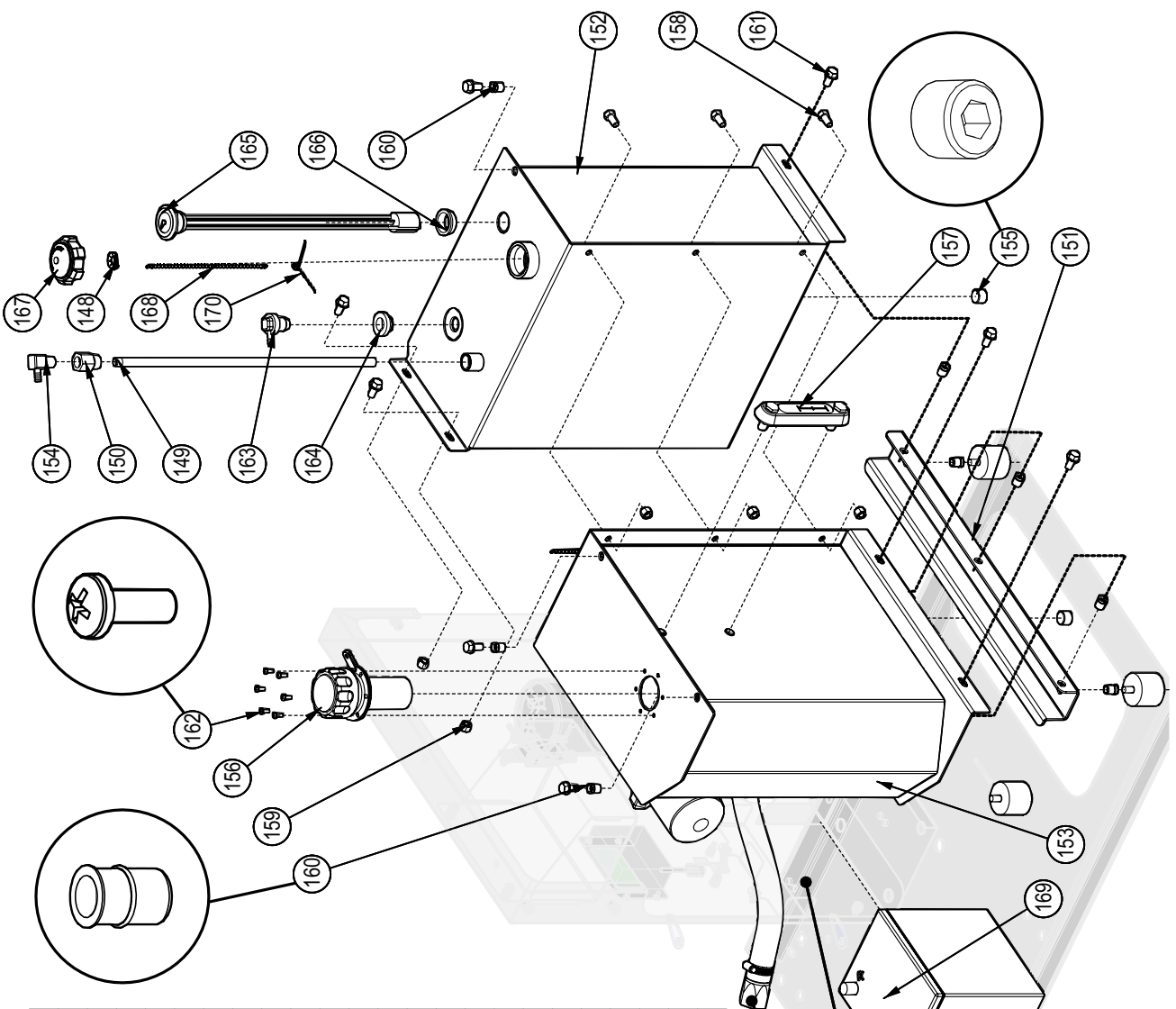

BOM ID	Description	Qty
148	1060L334 Lock Ring, Tether	1
149	1060S103 Fuel Pickup Tube	1
150	1060m103 Custom Adaptor MP08 x FP06	1
151	1061L159 Tank Isolator Rail	1
152	1061W112 Fuel Tank Weldment	1
153	1061W113 Hydraulic Tank Weldment	1
154	Z51189 Elbow 90 HB x MP 0506	1
155	Z51192 Socket Plug MP08	2
156	Z55403 Breather Filler Cap, Locking	1
157	Z55908 Reservoir Sight Level Thermometer	1
158	Z71307 Hex Bolt, 3/8NC x 3/4	3
159	Z72231 Hex Lock Nut, 3/8NC	5
160	Z72958 Riv-Nut 3/8NC x 150	8
161	Z76133 Flange Bolt, 3/8NC x 3/4	8
162	Z78303 Machine Screw, #10-32NF x 1/2	6
163	Z93110 Remote Vent 1/4" Barb	1
164	Z93111 Vent Grommet	1
165	Z93112 Fuel Gauge, Grommet x 18"	1
166	Z93115 Remote Fuel Gauge Grommet	1
167	Z93116 TIPS Rollover Fuel Cap - Diesel	1
168	Z93117 8" Ball Chain Lanyard	1
169	Z93205 Car Battery	1
170	Z93117-1 Tether Wireform 2-1/4"	1

See Hydraulic Tank Detail

Tank Shroud Weldment, CR70

Engine Skid Weldment, CR70

Hydraulic Tank Rear Detail

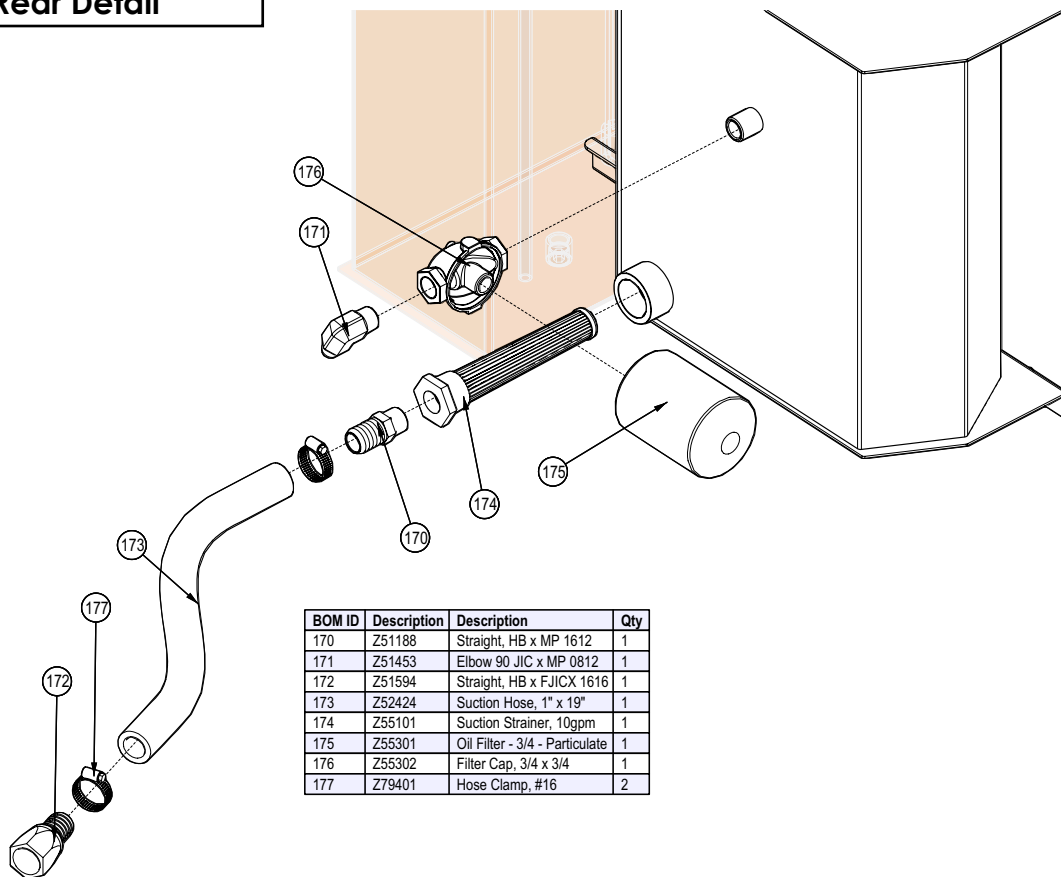

BOM ID	Description	Description	Qty
170	Z51188	Straight, HB x MP 1612	1
171	Z51453	Elbow 90 JIC x MP 0812	1
172	Z51594	Straight, HB x FJICX 1616	1
173	Z52424	Suction Hose, 1" x 19"	1
174	Z55101	Suction Strainer, 10gpm	1
175	Z55301	Oil Filter - 3/4" - Particulate	1
176	Z55302	Filter Cap, 3/4 x 3/4	1
177	Z79401	Hose Clamp, #16	2

Tank Compartment Shroud

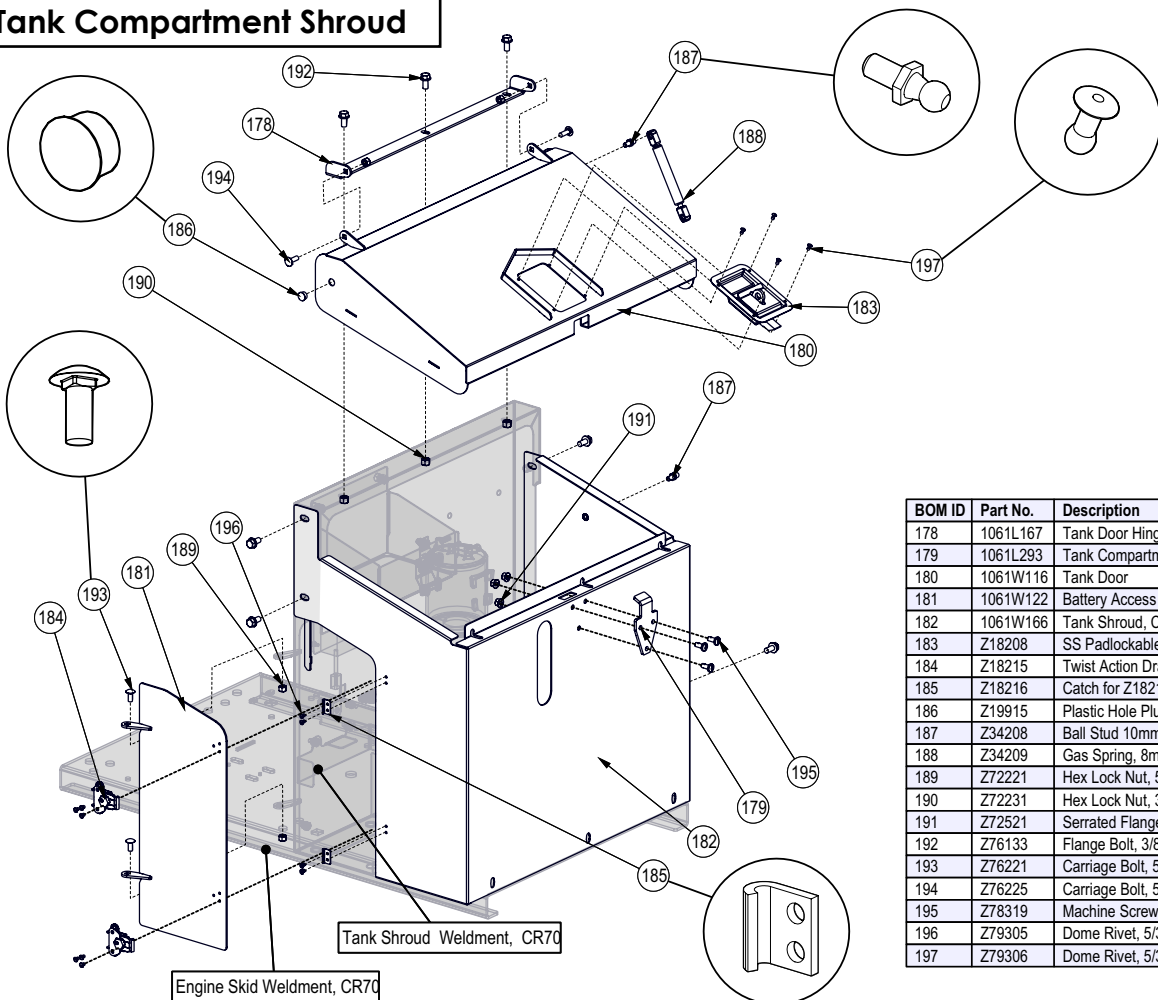

BOM ID	Part No.	Description	Qty
178	1061L167	Tank Door Hinge Rail	1
179	1061L293	Tank Compartment Strike Plate	1
180	1061W116	Tank Door	1
181	1061W122	Battery Access Door	1
182	1061W166	Tank Shroud, CR70	1
183	Z18208	SS Padlockable Paddle Latch	1
184	Z18215	Twist Action Draw Latch, 2-3/4"	2
185	Z18216	Catch for Z18215	2
186	Z19915	Plastic Hole Plug 9/16"	1
187	Z34208	Ball Stud 10mm x 5/16NC	2
188	Z34209	Gas Spring, 8mm x 3.15" Stroke 56lbs	1
189	Z72221	Hex Lock Nut, 5/16NC	4
190	Z72231	Hex Lock Nut, 3/8NC	3
191	Z72521	Serrated Flange Locknut, 5/16NC	3
192	Z76133	Flange Bolt, 3/8NC x 3/4	7
193	Z76221	Carriage Bolt, 5/16NC x 3/4	2
194	Z76225	Carriage Bolt, 5/16NC x 1	2
195	Z78319	Machine Screw, 5/16NC x 3/4" Locking	3
196	Z79305	Dome Rivet, 5/32" x 3/16"	8
197	Z79306	Dome Rivet, 5/32" x 1/4"	4

Discharge Chute

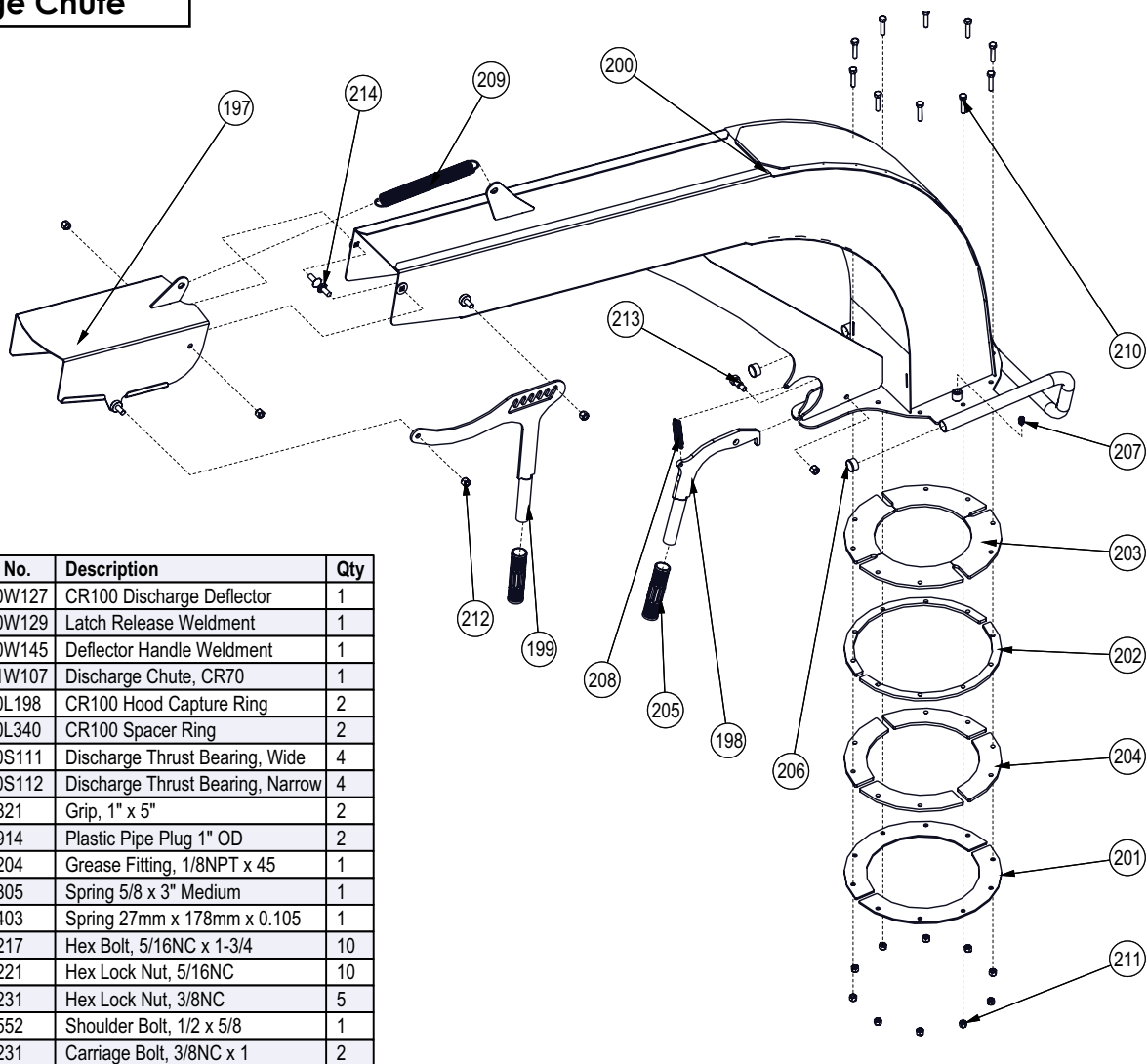

Rotor Housing Front

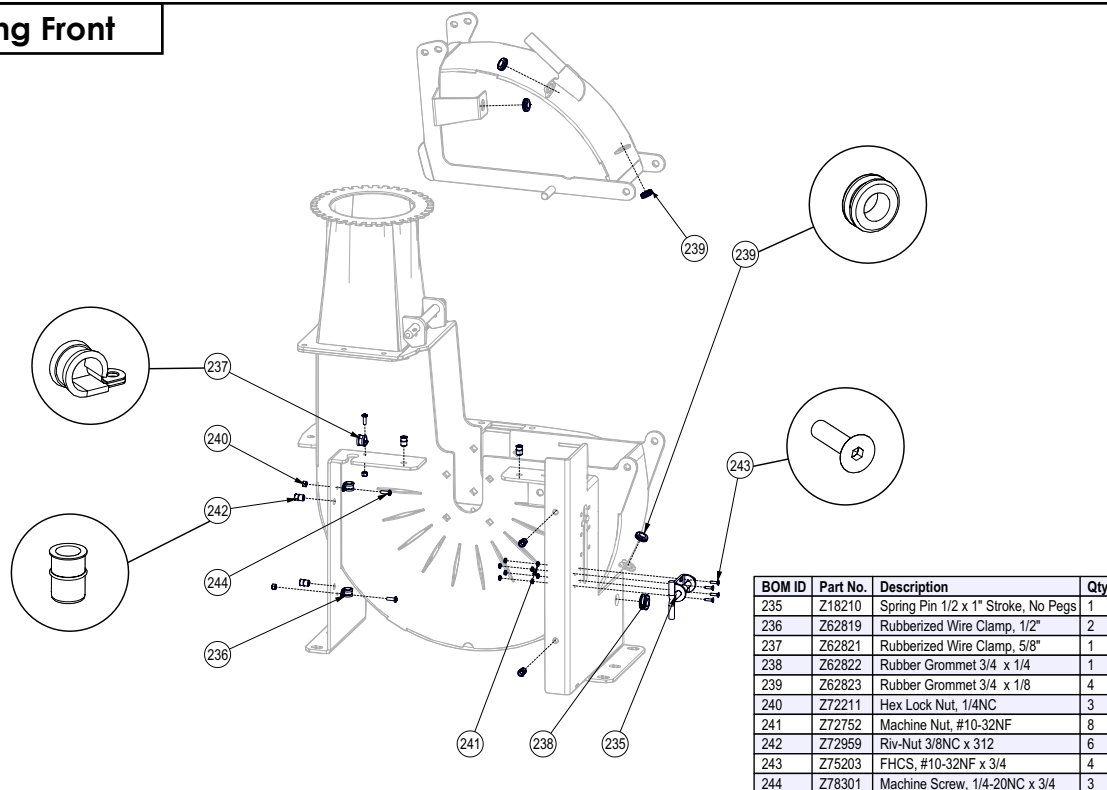

Rotor Housing Rear

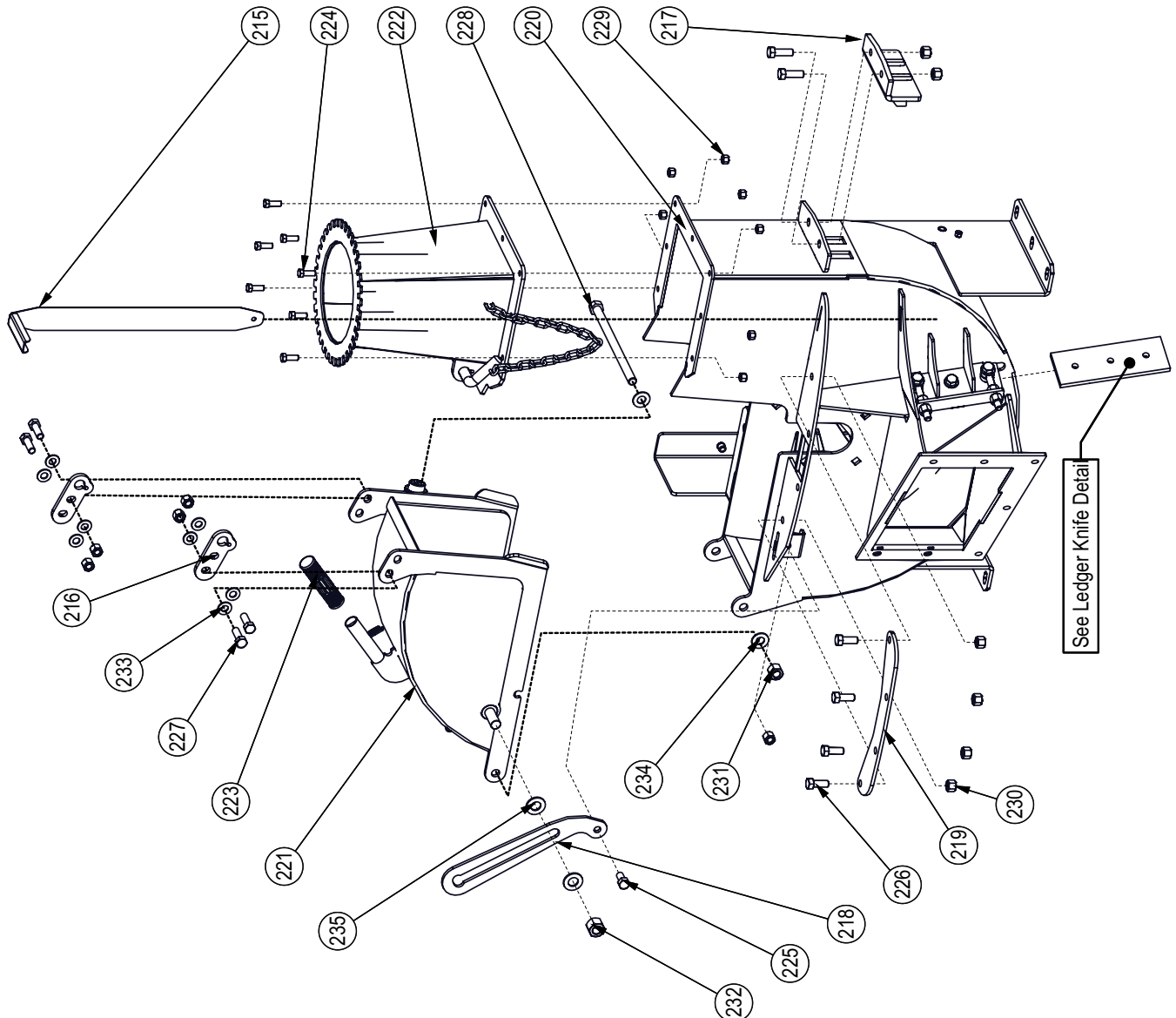

BOM ID	Part No.	Description	Qty
215	1012L269	Gauge, Ledger Setting	1
216	1060L284	Hood Closure Interface	2
217	1060W103	Twig Breaker, CR100	1
218	1061L142	Rotation Stop, CR70	1
219	1061L197	Rotor Tie Plate, CR70	1
220	1061W106	Lower Housing Weldment, CR70	1
221	1061W108	CR70 Upper Housing	1
222	1061W140	Square to Round Weldment, CR70	1
223	Z19321	Grip, 1" x 5"	1
224	Z71310	Hex Bolt, 3/8NC x 1	7
225	Z71510	Hex Bolt, 1/2NC x 1	1
226	Z71512	Hex Bolt, 1/2NC x 1-1/4	4
227	Z71515	Hex Bolt, 1/2NC x 1-1/2	6
228	Z71662	Hex Bolt, 5/8NC x 10	1
229	Z72231	Hex Lock Nut, 3/8NC	7
230	Z72251	Hex Lock Nut, 1/2NC	11
231	Z72261	Hex Lock Nut, 5/8NC	1
232	Z72271	Hex Lock Nut, 3/4NC	1
233	Z73151	Flat Washer, 1/2	8
234	Z73161	Flat Washer, 5/8	2
235	Z73171	Flat Washer, 3/4"	2
241	1012M204	Knife, BX62 Ledger	1
244	Z71579G8	Hex Bolt, 1/2NF x 1-3/4 Gr8	2
245	Z72251	Hex Lock Nut, 1/2NC	4
246	Z73151	Flat Washer, 1/2	3

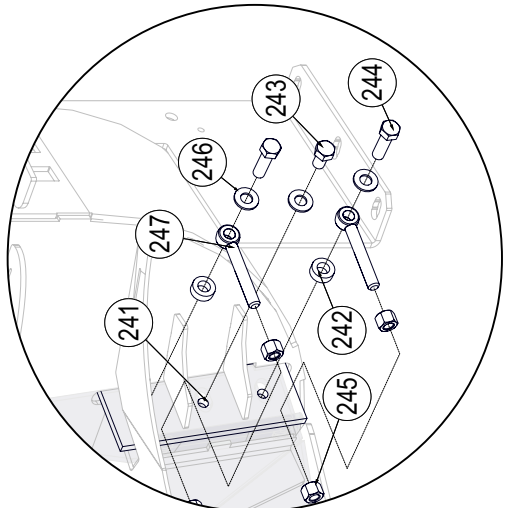

Rotor Interlock Latch

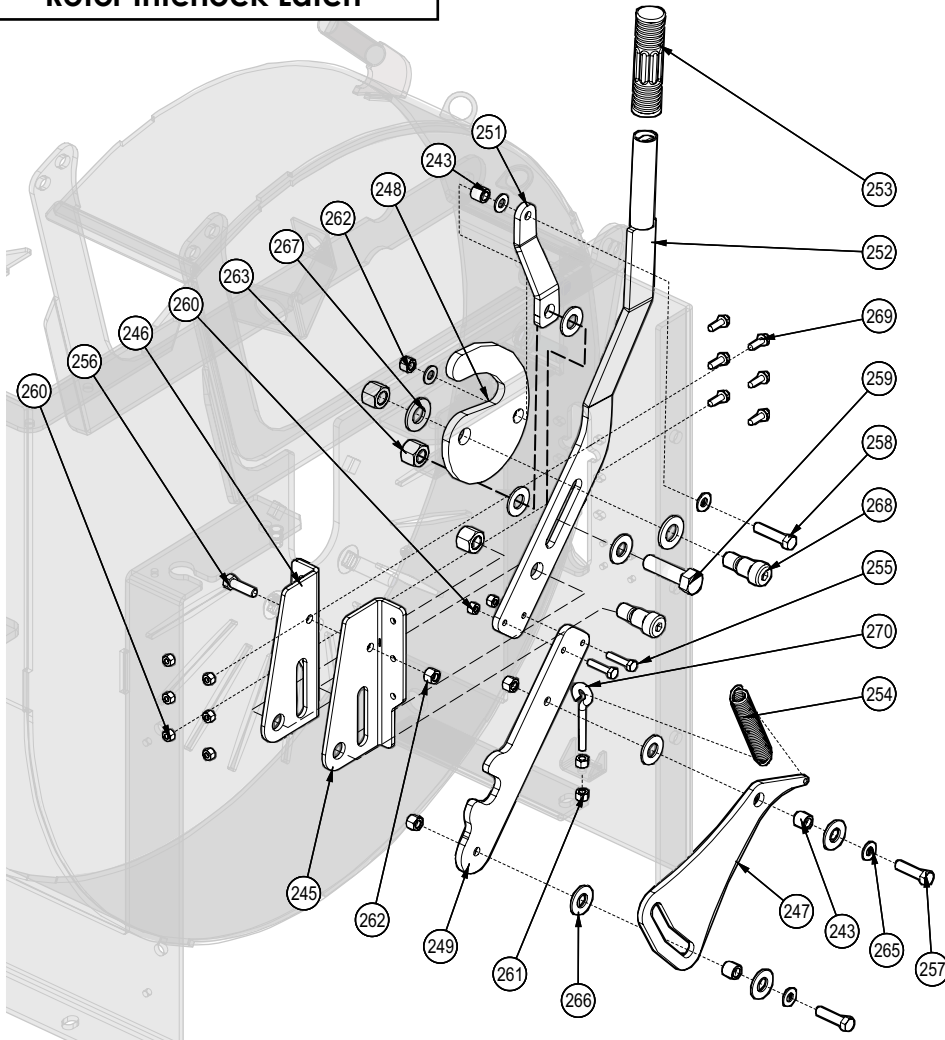

BOM ID	Part #	Description	Qty
243	1056M115	Spacer, Shredder .580	3
245	1060L281	Interlock Handle Base LH	1
246	1060L281H	1060L281 Mirror	1
247	1060L282	Interlock Early Warning	1
248	1060L287	Rotor Hood Safety Latch	1
249	1060L328	Interlock Tip	1
251	1060L330	Linkage	1
252	1060W256	Interlock Engage Handle	1
253	Z19321	Grip, 1" x 5"	1
254	Z31401	Spring 3/4 x 4" Heavy	1
255	Z71112	Hex Bolt, 1/4NC x 1-1/4	2
256	Z71312	Hex Bolt, 3/8NC x 1-1/4	1
257	Z71315	Hex Bolt, 3/8NC x 1-1/2	2
258	Z71317	Hex Bolt, 3/8NC x 1-3/4	1
259	Z71622	Hex Bolt, 5/8NC x 2-1/4	1
260	Z72211	Hex Lock Nut, 1/4NC	8
261	Z72221	Hex Lock Nut, 5/16NC	2
262	Z72231	Hex Lock Nut, 3/8NC	4
263	Z72261	Hex Lock Nut, 5/8NC	3
265	Z73131	Flat Washer, 3/8	5
266	Z73161	Flat Washer, 5/8	7
267	Z73171	Flat Washer, 3/4"	2
268	Z75572	Shoulder Bolt, 3/4 x 3/4	2
269	Z76111	Flange Bolt, 1/4NC x 3/4	6
270	Z76522	Eye Bolt 5/16NC x 2	1

Rotor Interlock Clutch

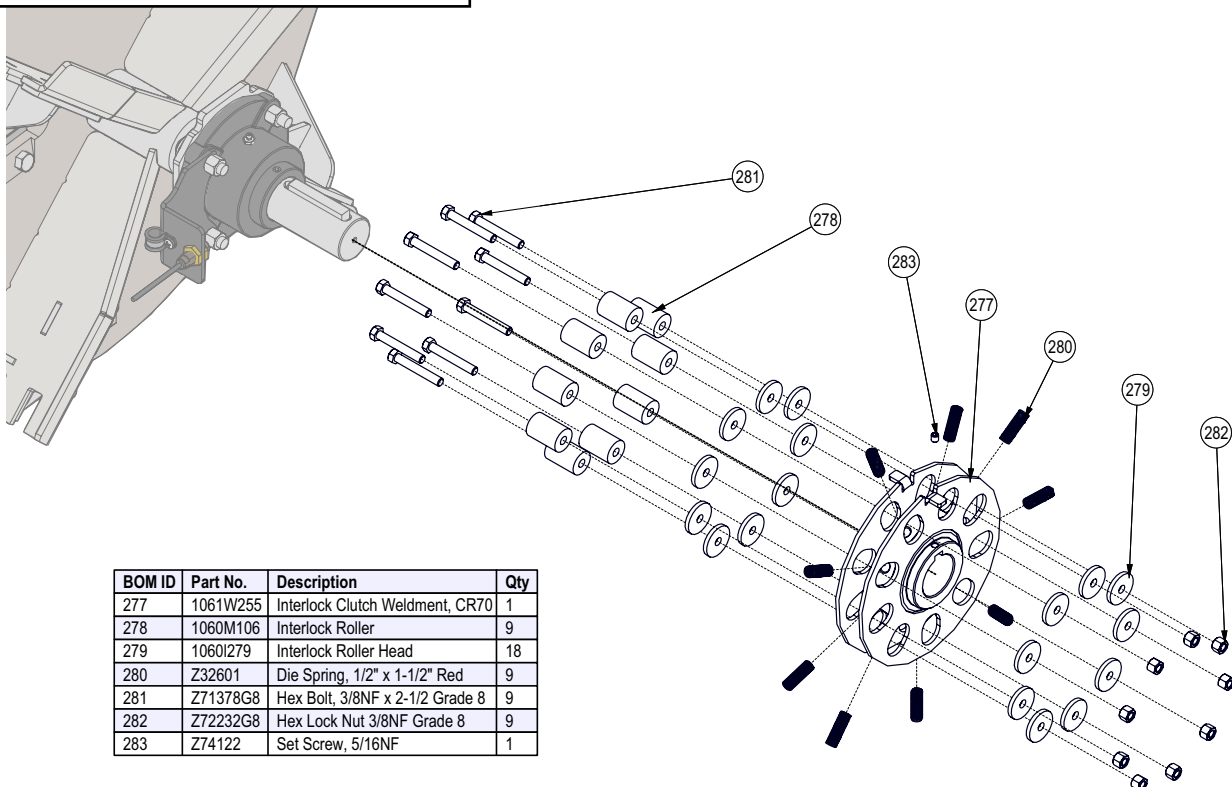

BOM ID	Part No.	Description	Qty
277	1061W255	Interlock Clutch Weldment, CR70	1
278	1060M106	Interlock Roller	9
279	1060I279	Interlock Roller Head	18
280	Z32601	Die Spring, 1/2" x 1-1/2" Red	9
281	Z71378G8	Hex Bolt, 3/8NF x 2-1/2 Grade 8	9
282	Z72232G8	Hex Lock Nut 3/8NF Grade 8	9
283	Z74122	Set Screw, 5/16NF	1

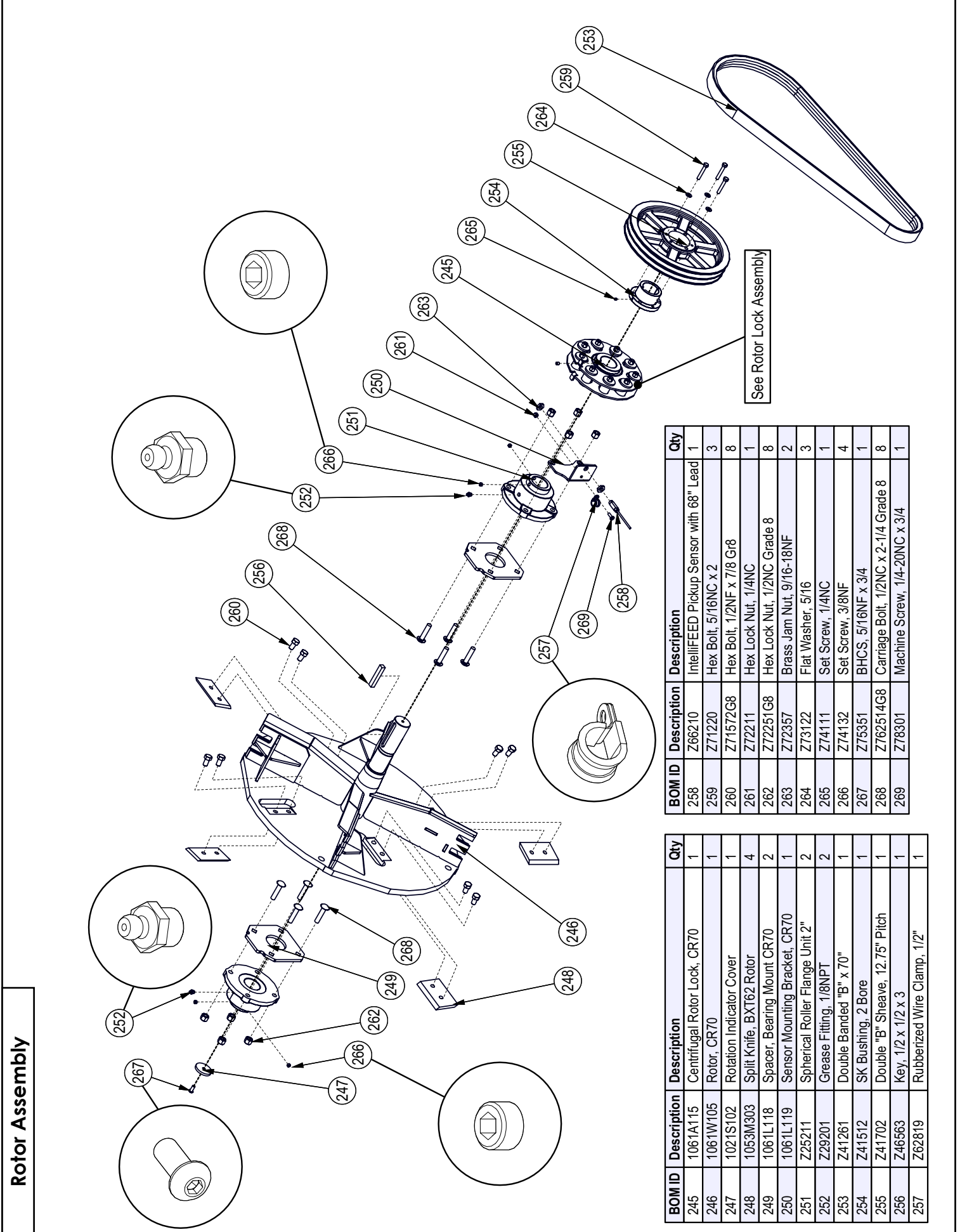

Rotor Assembly

BOM ID	Description	Description	Qty
258	Z66210	IntelliFEED Pickup Sensor with 68" Lead	1
259	Z71220	Hex Bolt, 5/16NC x 2	3
260	Z71572G8	Hex Bolt, 1/2NF x 7/8 Gr8	8
261	Z72211	Hex Lock Nut, 1/4NC	1
262	Z72251G8	Hex Lock Nut, 1/2NC Grade 8	8
263	Z72357	Brass Jam Nut, 9/16-18NF	2
264	Z73122	Flat Washer, 5/16	3
265	Z74111	Set Screw, 1/4NC	1
266	Z74132	Set Screw, 3/8NF	4
267	Z76351	BHCS, 5/16NF x 3/4	1
268	Z762514G8	Carriage Bolt, 1/2NC x 2-1/4 Grade 8	8
269	Z78301	Machine Screw, 1/4-20NC x 3/4	1

BOM ID	Description	Description	Qty
245	1061A115	Centrifugal Rotor Lock, CR70	1
246	1061W105	Rotor, CR70	1
247	1021S102	Rotation Indicator Cover	1
248	1053M303	Split Knife, BXT62 Rotor	4
249	1061L118	Spacer, Bearing Mount CR70	2
250	1061L119	Sensor Mounting Bracket, CR70	1
251	Z25211	Spherical Roller Flange Unit 2"	2
252	Z29201	Grease Fitting, 1/8NPT	2
253	Z41261	Double Banded "B" x 70"	1
254	Z41512	SK Bushing, 2 Bore	1
255	Z41702	Double "B" Sheave, 12.75" Pitch	1
256	Z46563	Key, 1/2 x 1/2 x 3	1
257	Z62819	Rubberized Wire Clamp, 1/2"	1

Pulley Shroud

BOM ID	Part No.	Description	Qty
284	1061L266	Coupler Shield Sub-Base	1
285	1061L263	Belt Shield Sub-Base	1
288	1061L190	Hydraulic - Coupler Shield	1
289	1061L191	Hose Cover	1
290	1061L264	CR70 Belt Shield	1
291	1061L265	Fluid Coupler Shield	1
297	Z71240	Hex Bolt, 5/16NC x 4"	2
298	Z72221	Hex Lock Nut, 5/16NC	4
299	Z72321	Jam Nut, 5/16NC	2
300	Z72914	Acorn Nut, 5/16NC	2
301	Z72955	Riv-Nut 1/4NC x 165	8
302	Z76111	Flange Bolt, 1/4NC x 3/4	8
303	Z76133	Flange Bolt, 3/8NC x 3/4	13
304	Z79141	Threaded Stud, 5/16NC x 4"	2
306	Z72958	Riv-Nut 3/8NC x 150	6

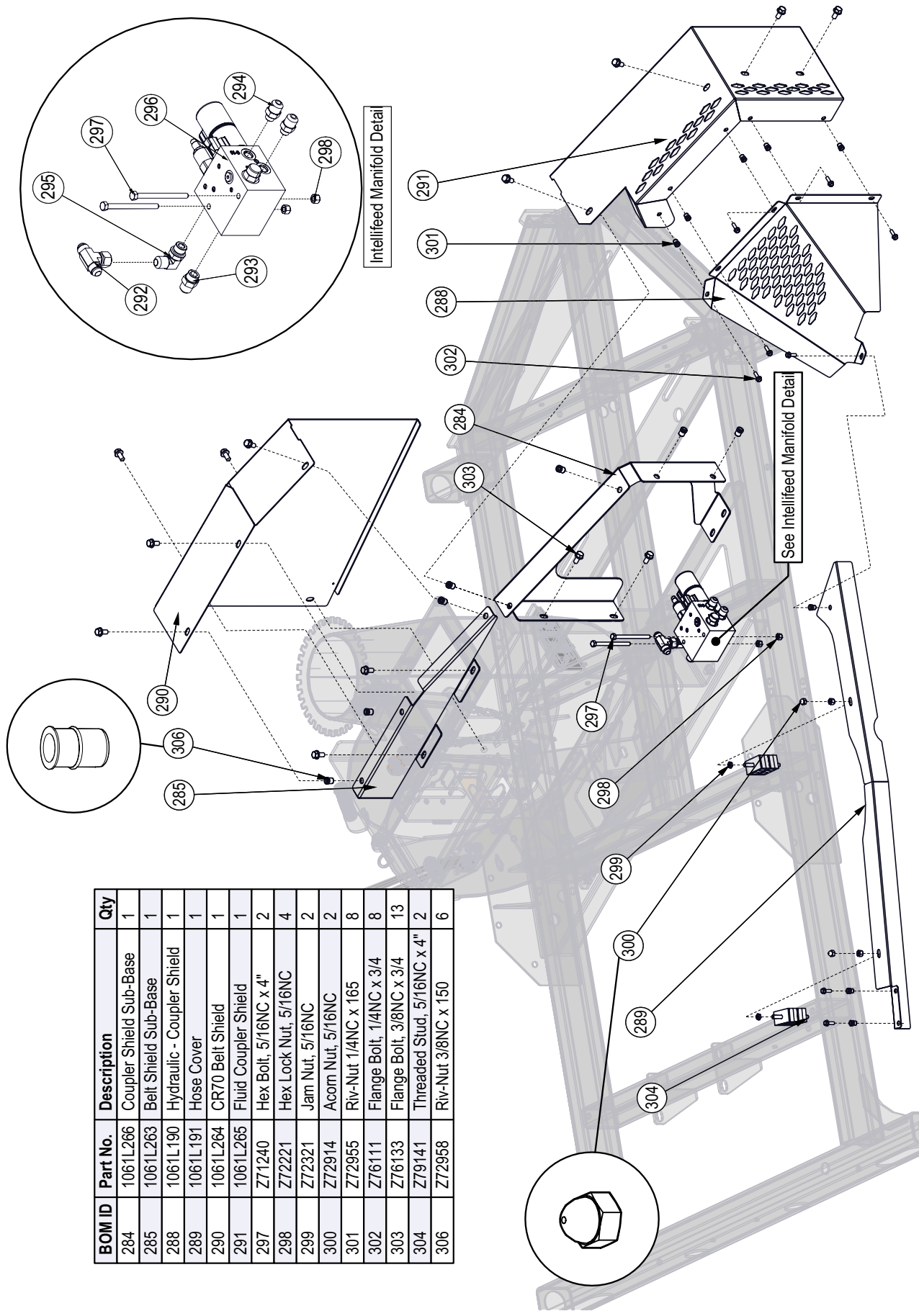

Hopper Top / Back View

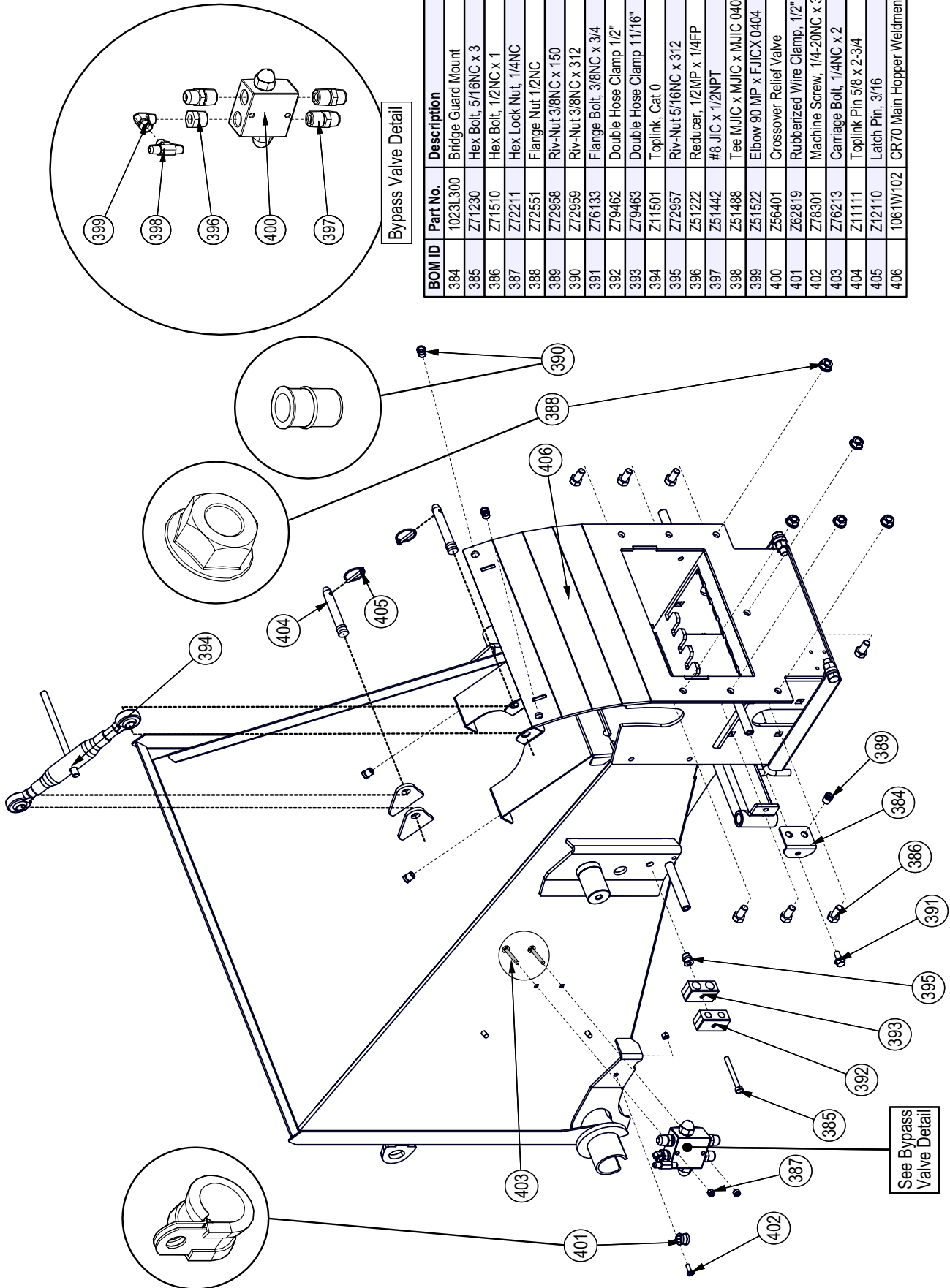

BOM ID	Part No.	Description	Qty
384	1023L300	Bridge Guard Mount	1
385	Z71230	Hex Bolt, 5/16NC x 3	1
386	Z71510	Hex Bolt, 1/2NC x 1	7
387	Z72211	Hex Lock Nut, 1/4NC	3
388	Z72551	Flange Nut 1/2NC	5
389	Z72988	Riv-Nut 3/8NC x 150	3
390	Z72989	Riv-Nut 3/8NC x 312	2
391	Z76133	Flange Bolt, 3/8NC x 3/4	1
392	Z79462	Double Hose Clamp 1/2"	1
393	Z79463	Double Hose Clamp 1 1/16"	1
394	Z11501	Toplink, Cat 0	1
395	Z72957	Riv-Nut 5/16NC x 312	1
396	Z51222	Reducer, 1/2MP x 1/4FFP	1
397	Z51442	#8 JIC x 1/2NPT	2
398	Z51488	Tee MJIC x MJIC x MJIC 040404	1
399	Z51522	Elbow 90 MP x FJICX 0404	1
400	Z56401	Crossover Relief Valve	1
401	Z62819	Rubberized Wire Clamp, 1/2"	1
402	Z78301	Machine Screw, 1/4-20NC x 3/4	1
403	Z76213	Carriage Bolt, 1/4NC x 2	2
404	Z11111	Toplink Pin 5/8 x 2-3/4	2
405	Z12110	Latch Pin, 3/16	2
406	1061W102	CR70 Main Hopper Weldment	1

Upper Roller Right Pivot Arm

**Seal Kit for
#Z54201 Geroller
Motor, 315C4UE
SK MLHR-U/D,E**

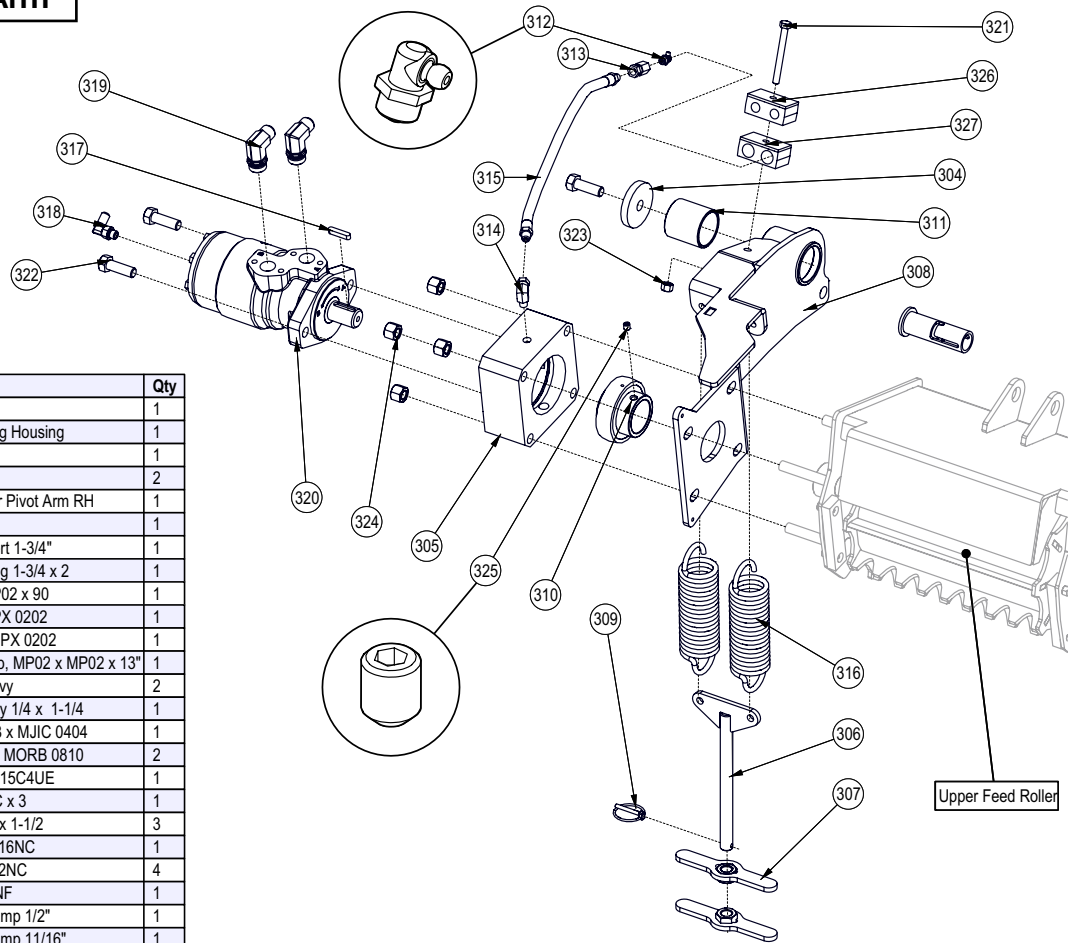

BOM ID	Part No.	Description	Qty
304	1015L618	Capture Washer	1
305	1022M218	UC Motor Bearing Housing	1
306	1022W206	Spring Yoke	1
307	1022W220	Nut Handle	2
308	1061W103H	Weldment, Roller Pivot Arm RH	1
309	Z12110	Latch Pin, 3/16	1
310	Z21903	Ball Bearing Insert 1-3/4"	1
311	Z27101	Fiberglide Bearing 1-3/4 x 2	1
312	Z29207	Grease Zerk, MP02 x 90	1
313	Z29302	Straight, FP x FFX 0202	1
314	Z29307	Elbow 90 MP x FFX 0202	1
315	Z29312	1/4" Grease Whip, MP02 x MP02 x 13"	1
316	Z31501	Spring 2 x 7 Heavy	2
317	Z46594	Blind Chipper Key 1/4 x 1-1/4	1
318	Z51657	Elbow 90, MORB x MJIC 0404	1
319	Z51658	Elbow 90 MJIC x MORB 0810	2
320	Z54201	Geroller Motor, 315C4UE	1
321	Z71230	Hex Bolt, 5/16NC x 3	1
322	Z71515	Hex Bolt, 1/2NC x 1-1/2	3
323	Z72221	Hex Lock Nut, 5/16NC	1
324	Z72251	Hex Lock Nut, 1/2NC	4
325	Z74122	Set Screw, 5/16NF	1
326	Z79462	Double Hose Clamp 1/2"	1
327	Z79463	Double Hose Clamp 11/16"	1

Upper Roller Left Pivot Arm

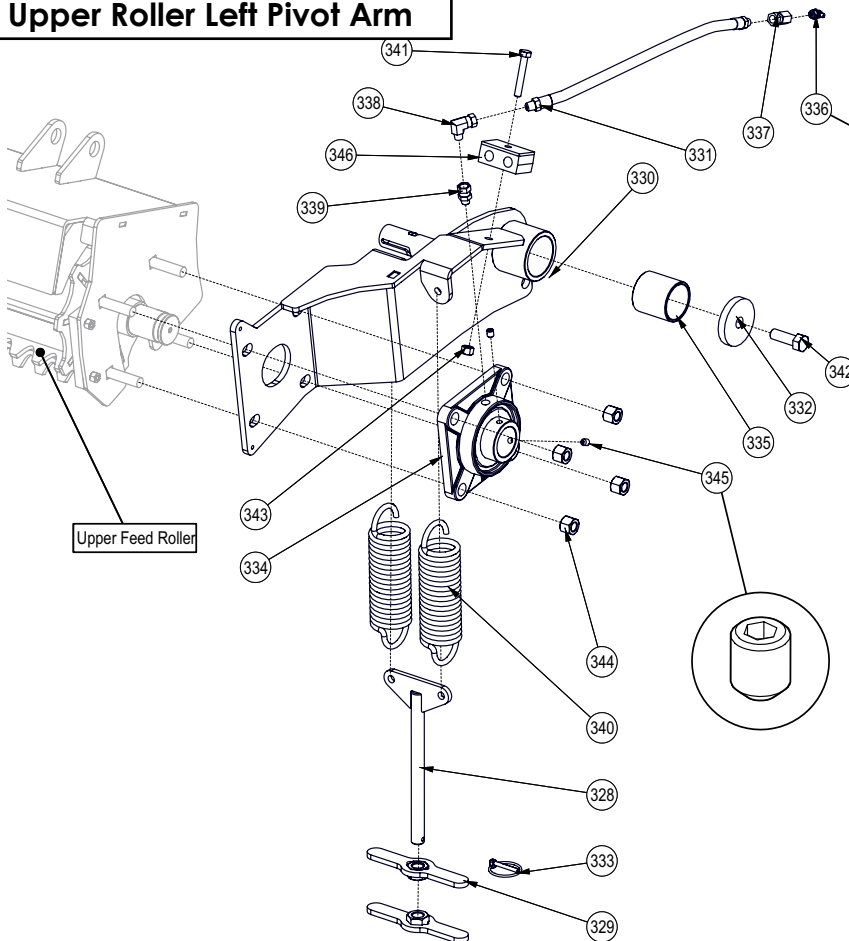

BOM ID	Part No.	Description	Qty
328	1022W206	Spring Yoke	1
329	1022W220	Nut Handle	2
330	1061W103	Weldment, Roller Pivot Arm LH	1
331	Z29312	1/4" Grease Whip, MP02 x MP02 x 13"	1
332	1015L618	Capture Washer	1
333	Z12110	Latch Pin, 3/16	1
334	Z25204	4-Bolt Bearing 1-1/2" Bore	1
335	Z27101	Fiberglide Bearing 1-3/4 x 2	1
336	Z29207	Grease Zerk, MP02 x 90	1
337	Z29302	Straight, FP x FFX 0202	1
338	Z29307	Elbow 90 MP x FFX 0202	1
339	Z29311	Straight, MP x FFX 0202	1
340	Z31501	Spring 2 x 7 Heavy	2
341	Z71220	Hex Bolt, 5/16NC x 2	1
342	Z71515	Hex Bolt, 1/2NC x 1-1/2	1
343	Z72221	Hex Lock Nut, 5/16NC	1
344	Z72251	Hex Lock Nut, 1/2NC	4
345	Z74122	Set Screw, 5/16NF	2
346	Z79462	Double Hose Clamp 1/2"	1

Upper Roller Assembly

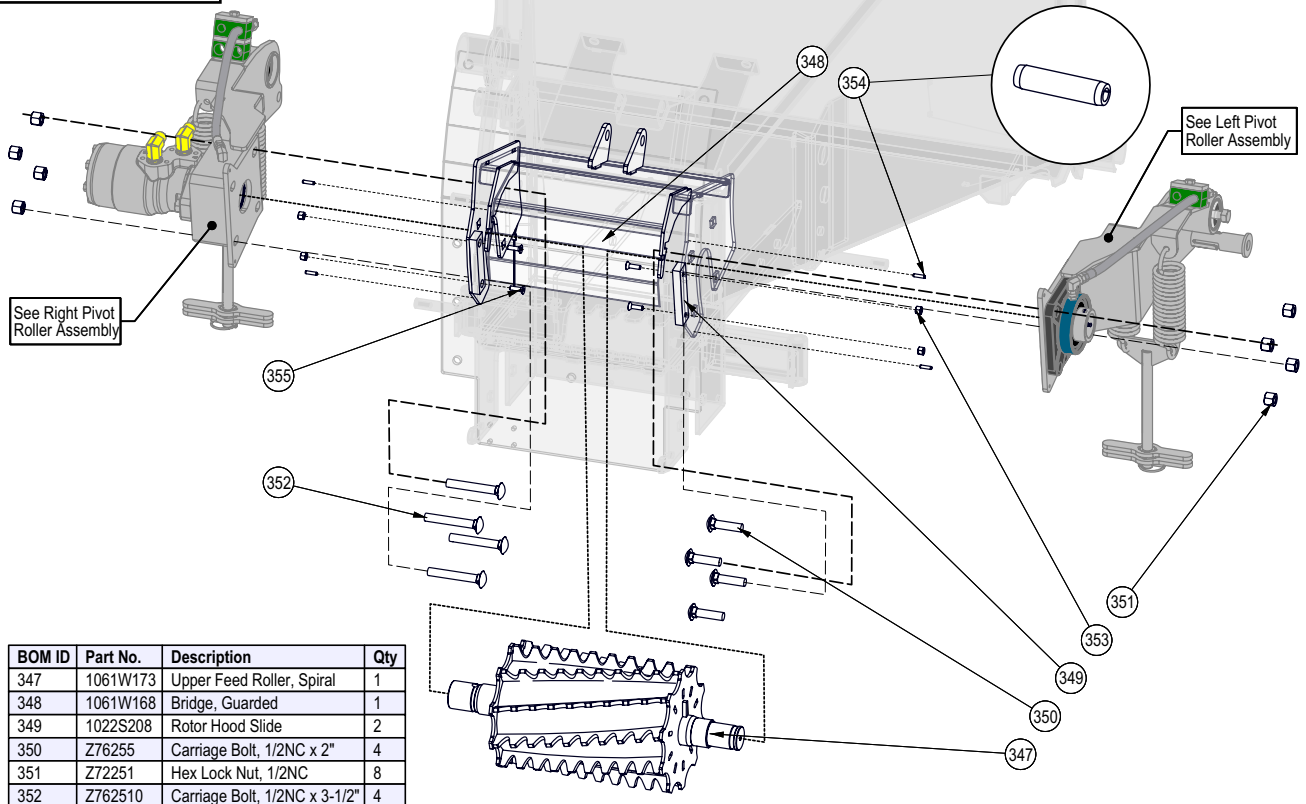

BOM ID	Part No.	Description	Qty
347	1061W173	Upper Feed Roller, Spiral	1
348	1061W168	Bridge, Guarded	1
349	1022S208	Rotor Hood Slide	2
350	Z76255	Carriage Bolt, 1/2NC x 2"	4
351	Z72251	Hex Lock Nut, 1/2NC	8
352	Z762510	Carriage Bolt, 1/2NC x 3-1/2"	4
353	Z72211	Hex Lock Nut, 1/4NC	4
354	Z14152	Roll Pin, 3/16" x 3/4"	4
355	Z75211	FHCS, 1/4NC x 7/8"	4

Lower Roller Assembly

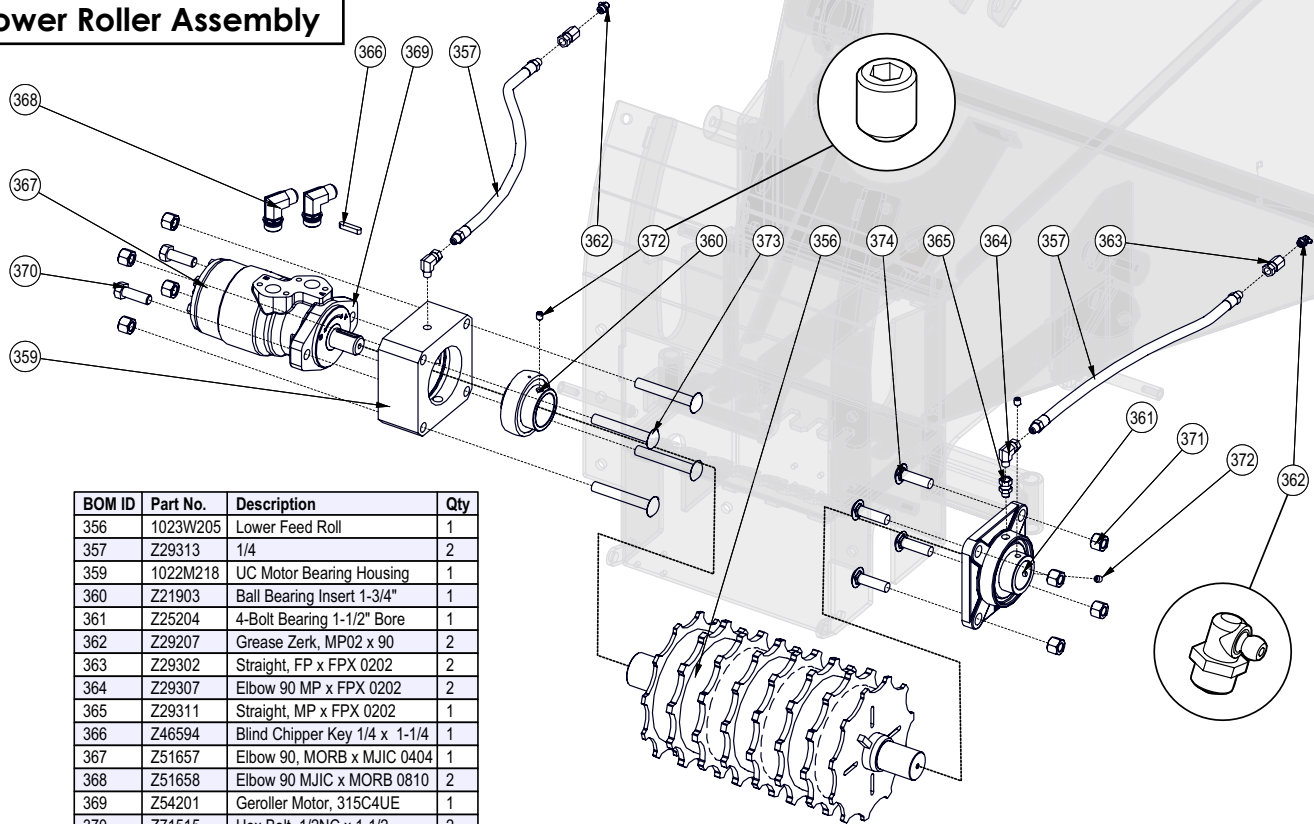

BOM ID	Part No.	Description	Qty
356	1023W205	Lower Feed Roll	1
357	Z29313	1/4	2
359	1022M218	UC Motor Bearing Housing	1
360	Z21903	Ball Bearing Insert 1-3/4"	1
361	Z25204	4-Bolt Bearing 1-1/2" Bore	1
362	Z29207	Grease Zerk, MP02 x 90	2
363	Z29302	Straight, FP x FPX 0202	2
364	Z29307	Elbow 90 MP x FPX 0202	2
365	Z29311	Straight, MP x FPX 0202	1
366	Z46594	Blind Chipper Key 1/4 x 1-1/4	1
367	Z51657	Elbow 90, MORB x MJIC 0404	1
368	Z51658	Elbow 90 MJIC x MORB 0810	2
369	Z54201	Geroller Motor, 315C4UE	1
370	Z71515	Hex Bolt, 1/2NC x 1-1/2	2
371	Z72251	Hex Lock Nut, 1/2NC	8
372	Z74122	Set Screw, 5/16NF	3
373	Z762510	Carriage Bolt, 1/2NC x 3-1/2	4
374	Z76258	Carriage Bolt, 1/2NC x 1-3/4	4

**Seal Kit for
#Z54201 Geroller Motor, 315C4UE
SK MLHR-U/D,E**

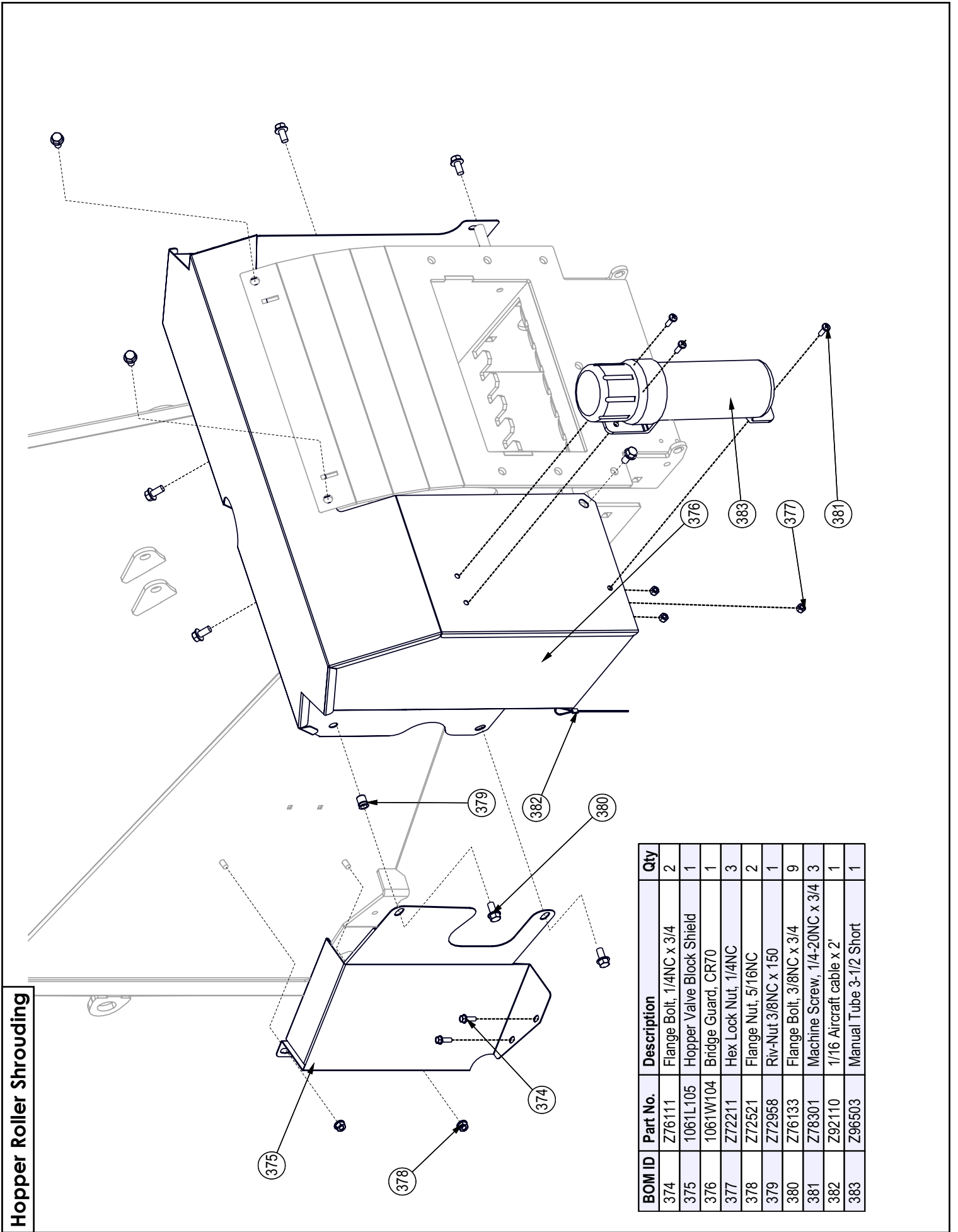

Hopper Roller Shrouding

BOM ID	Part No.	Description	Qty
374	Z76111	Flange Bolt, 1/4NC x 3/4	2
375	1061L105	Hopper Valve Block Shield	1
376	1061W104	Bridge Guard, CR70	1
377	Z72211	Hex Lock Nut, 1/4NC	3
378	Z72521	Flange Nut, 5/16NC	2
379	Z72958	Riv-Nut 3/8NC x 150	1
380	Z76133	Flange Bolt, 3/8NC x 3/4	9
381	Z78301	Machine Screw, 1/4-20NC x 3/4	3
382	Z92110	1/16 Aircraft cable x 2'	1
383	Z96503	Manual Tube 3-1/2 Short	1

Feed Table

BOM ID	Part No.	Description	Qty
417	1015S538	U-bolt, Bearing Adapter	5
418	1022W230	Feed Table Trap Plate Weldment	1
419	1022W230H	Feed Table Trap Weldment, LH	1
420	1023S203	Feed Control Handle	1
421	1060L302	CR100 Feed Switch Guard	1
422	1060L306	Feed Control Pivot, CR100	1
423	1061W101	CR70 Feed Table Weldment	1
424	Z18207	Spring Latch Pin 1/2 x 1" Stroke	2
425	Z62819	Rubberized Wire Clamp, 1/2"	1
426	Z72211	Hex Lock Nut, 1/4NC	1
427	Z72221	Hex Lock Nut, 5/16NC	10
428	Z72271	Hex Lock Nut, 3/4NC	1
429	Z72752	Machine Nut, #10-32NF	8
430	Z72911	Acorn Nut, 3/8NC	12
431	Z73111	Flat Washer, 1/4	1
432	Z73171	Flat Washer, 3/4"	1
433	Z76133	Flange Bolt, 3/8NC x 3/4	4
434	Z76233	Carriage Bolt, 3/8NC x 3/4	12
435	Z78301	Machine Screw, 1/4-20NC x 3/4	1
436	Z78303	Machine Screw, #10-32NF x 1/2	8

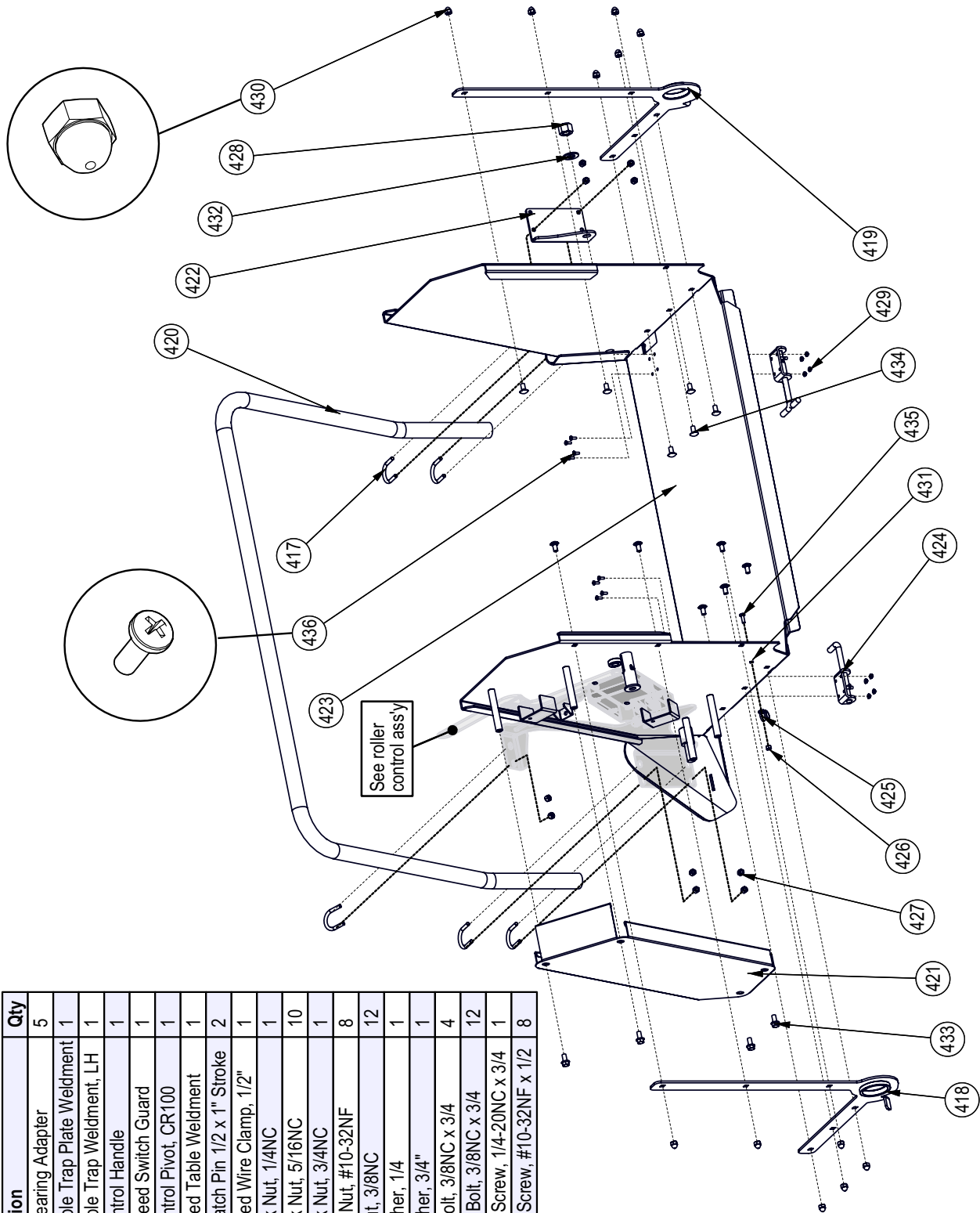

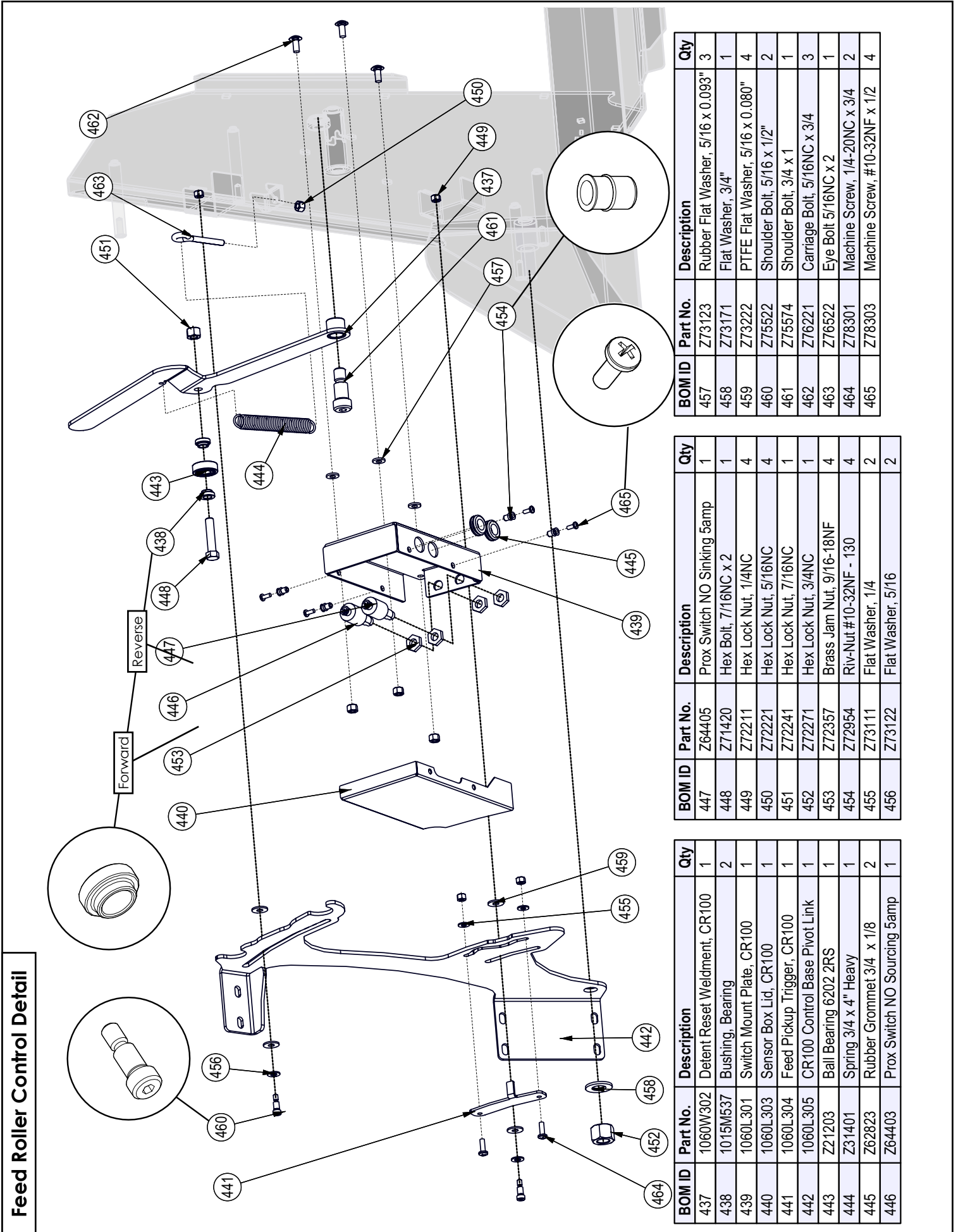

Feed Roller Control Detail

BOM ID	Part No.	Description	Qty
457	Z73123	Rubber Flat Washer, 5/16 x 0.093"	3
458	Z73171	Flat Washer, 3/4"	1
459	Z73222	PTFE Flat Washer, 5/16 x 0.080"	4
460	Z75522	Shoulder Bolt, 5/16 x 1/2"	2
461	Z75574	Shoulder Bolt, 3/4 x 1	1
462	Z76221	Carriage Bolt, 5/16NC x 3/4	3
463	Z76522	Eye Bolt 5/16NC x 2	1
464	Z78301	Machine Screw, 1/4-20NC x 3/4	2
465	Z78303	Machine Screw, #10-32NF x 1/2	4

BOM ID	Part No.	Description	Qty
447	Z64405	Prox Switch NO Sinking 5amp	1
448	Z71420	Hex Bolt, 7/16NC x 2	1
449	Z72211	Hex Lock Nut, 1/4NC	4
450	Z72221	Hex Lock Nut, 5/16NC	4
451	Z72241	Hex Lock Nut, 7/16NC	1
452	Z72271	Hex Lock Nut, 3/4NC	1
453	Z72357	Brass Jam Nut, 9/16-18NF	4
454	Z72954	Riv-Nut #10-32NF - 130	4
455	Z73111	Flat Washer, 1/4	2
456	Z73122	Flat Washer, 5/16	2

BOM ID	Part No.	Description	Qty
437	1060W302	Detent Reset Weldment, CR100	1
438	1015M537	Bushing, Bearing	2
439	1060L301	Switch Mount Plate, CR100	1
440	1060L303	Sensor Box Lid, CR100	1
441	1060L304	Feed Pickup Trigger, CR100	1
442	1060L305	CR100 Control Base Pivot Link	1
443	Z21203	Ball Bearing 6202 2RS	1
444	Z31401	Spring 3/4 x 4" Heavy	1
445	Z62823	Rubber Grommet 3/4 x 1/8	2
446	Z64403	Prox Switch NO Sourcing 5amp	1

Intellifeed Wiring Harness & Lights and Brakes Wiring Harness

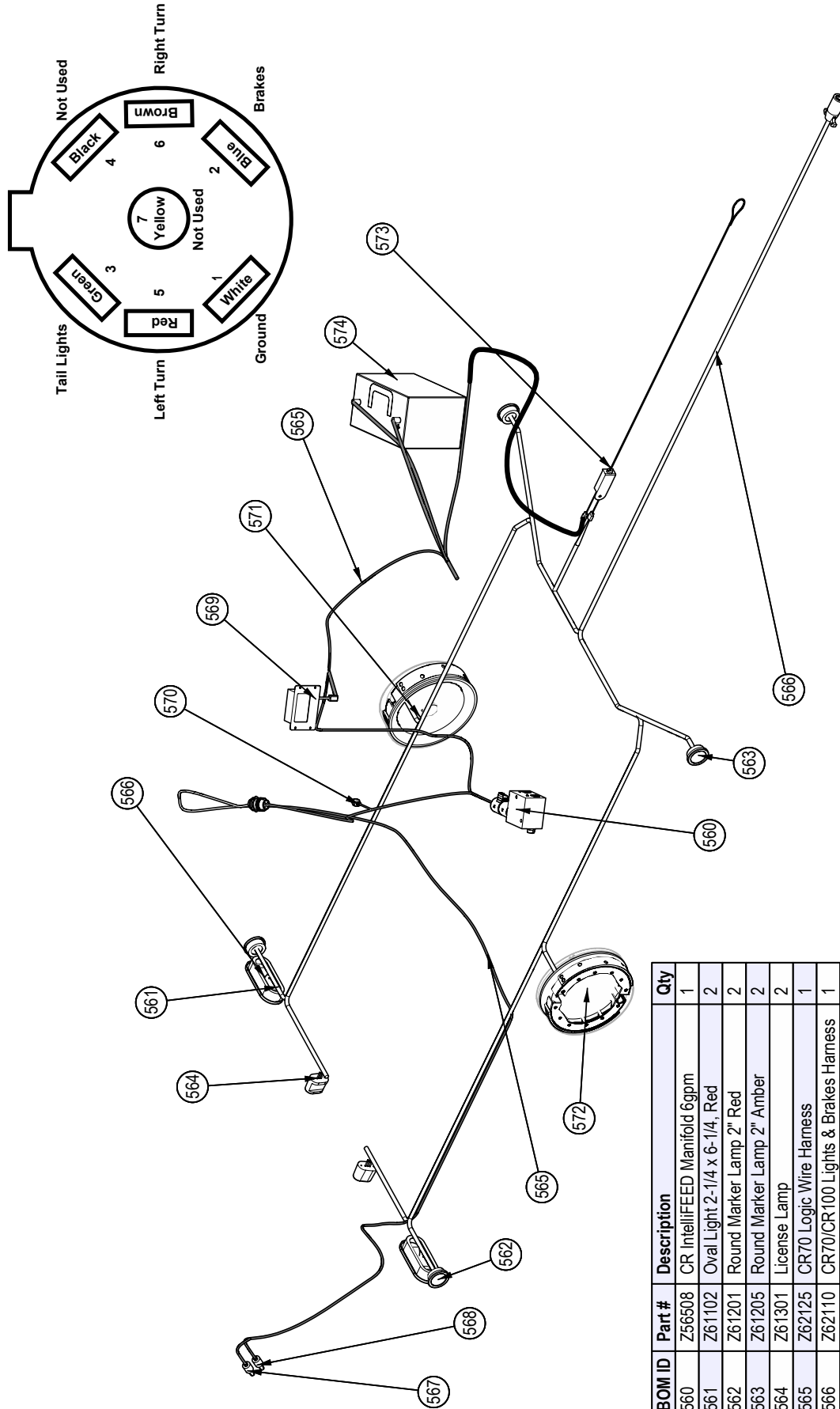

Light Bulb Replacement	
Part #	Description
Z61201	Round Marker Lamp 2" Red
Z61205	Round Marker Lamp 2" Amber
Z61102	Oval Light 2 1/4 x 6 1/4, Red
Z61301	License Lamp

BOM ID	Part #	Description	Qty
560	Z56508	CR IntelliFEED Manifold 6gpm	1
561	Z61102	Oval Light 2-1/4 x 6-1/4, Red	2
562	Z61201	Round Marker Lamp 2" Red	2
563	Z61205	Round Marker Lamp 2" Amber	2
564	Z61301	License Lamp	2
565	Z62125	CR70 Logic Wire Harness	1
566	Z62110	CR70/CR100 Lights & Brakes Harness	1
567	Z64403	Prox Switch NO Sourcing 5amp	1
568	Z64405	Prox Switch NO Sinking 5amp	1
569	Z66204	Control, IntelliFEED	1
570	Z66210	IntelliFEED Pickup Sensor with 68" Lead	1
571	Z91708	Electric Brake, 2 1/4 x10 LH	1
572	Z91719	Electric Brake, 2 1/4 x10 RH	1
573	Z91713	Breakaway Safety Switch	1
574	Z93205	Car Battery	1

Hydraulic Hose Parts List

The Chart below is a complete list of hydraulic hoses for the CR70. For information on your model and its hose connections please review the hydraulic schematics on the following pages.

Part Number	Description	Qty
Z52126	1/4" Hose, FJIC04 x 90FJIC04 x 34"	1
Z52127	1/4" Hose, FJIC04 x 90FJIC04 x 26"	1
Z52250	3/8" Hose, FJIC08 x 90FJIC08 x 23"	2
Z52281	3/8" Hose, FJIC08 x 90FJIC08 x 68"	1
Z52282	3/8" Hose, FJIC08 x 90FJIC08 x 56"	1
Z52283	3/8" Hose, FJIC08 x 90FJIC08 x 75"	1
Z52353	1/2" Hose, 90FJIC08 x 90FJIC08 x 42"	1
Z52354	1/2" Hose, FJIC08 x FJIC08 x 38"	1
Z52424	Suction Hose, 1" x 19"	1

Hydraulic Schematic

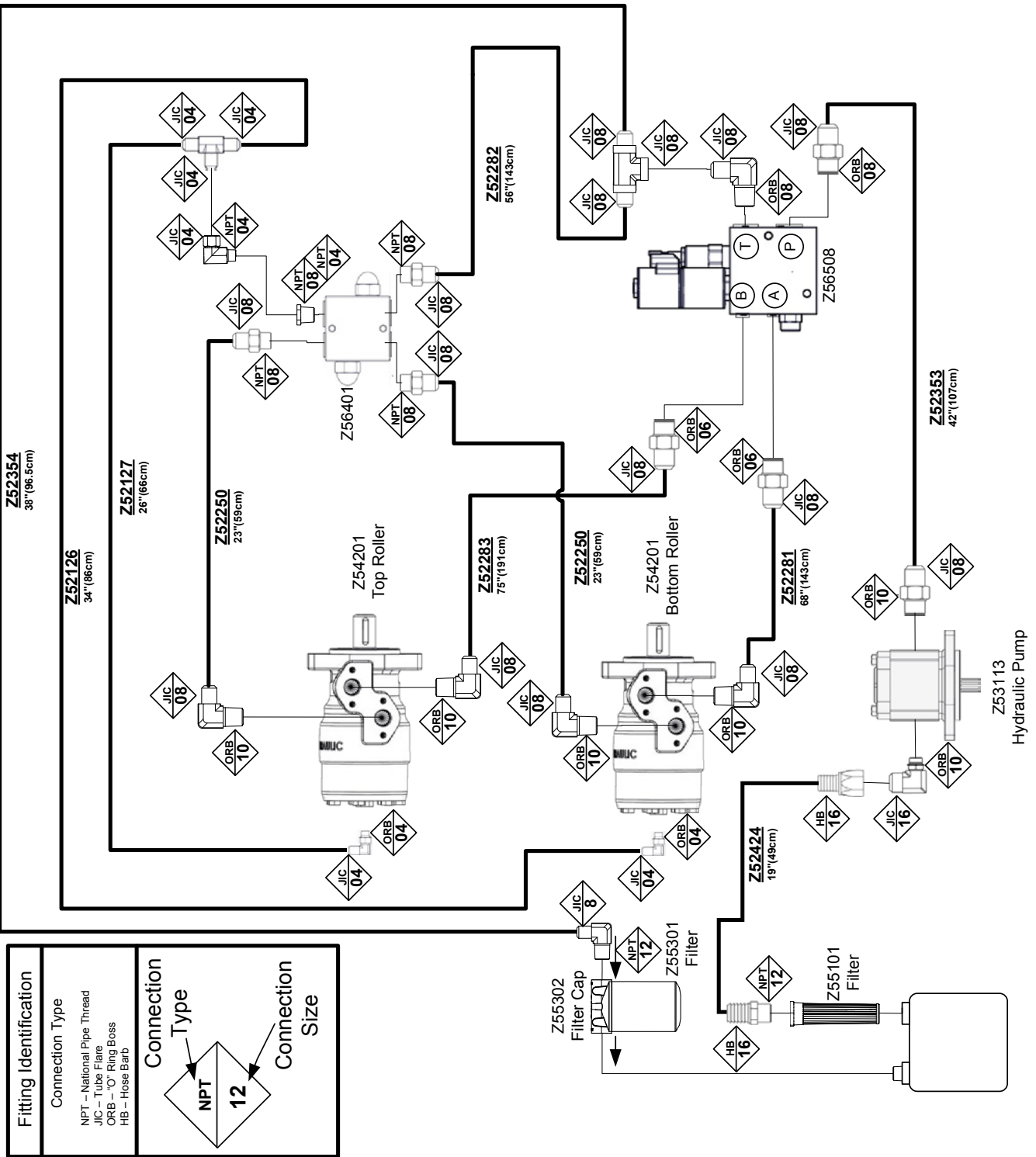

CR70: Label Part Number & Designation List

Prt No.	Description	CR70	CR70EU	CR70D	CR70DEU	CR70TD	CR70TDEU
Z94646	CR70 Model # Decal (Toolbox)	1					
Z94647	CR70 Model # Decal (Engine)	1					
Z946215	CR70 Feed Table Decal	1					
Z946111	CR70eu Model # Decal (Toolbox)		1				
Z946112	CR70eu Model # Decal (Engine)		1				
Z946201	CR70eu Feed Table Decal		1				
Z946210	CR70d Model # Decal (Toolbox)			1			
Z946209	CR70d Model # Decal (Engine)			1			
Z946211	CR70d Feed Table Decal			1			
Z946221	CR70deu Model # Decal (Toolbox)				1		
Z946220	CR70deu Model # Decal (Engine)				1		
Z946222	CR70deu Feed Table Decal				1		
Z946207	CR70td Model # Decal (Engine)					1	
Z946206	CR70td Model # Decal (Toolbox)					1	
Z946208	CR70td Feed Table Decal					1	
Z946212	CR70tdeu Model # Decal (Toolbox)						1
Z946213	CR70tdeu Model # Decal (Engine)						1
Z946214	CR70tdeu Feed Table Decal						1
Z94115	Fire Hazard - No Smoking	2	2	2	2	2	2
Z94116	Driveline - Arm Entanglement Hazard - Keep Hands Away	1	1	1	1	1	1
Z94117	Flying Object Hazard - Keep Back	4	4	4	4	4	4
Z94119	Hazard - Read Manual	2	2	2	2	2	2
Z94120	Rotating Cutter Hazard - Keep Hands Away	6	6	6	6	6	6
Z94124	Decal-Warning Hands	2	2	2	2	2	2
Z94127	Ce Warning Rotating Part	2	2	2	2	2	2
Z94127	Driveline - Hand Entanglement Hazard - Keep Hands Away	1	1	1	1	1	1
Z94143	Noise - 121db Noise	1	1	1	1	1	1
Z94144	Rh Rotation Decal	1	1	1	1	1	1
Z94145	Lh Rotation Decal	1	1	1	1	1	1
Z94167	Hydraulic Rupture Hazard - Keep Back	4	4	4	4	4	4
Z94207	Entanglement Hazard - Do Not Climb In Hopper	4	4	4	4	4	4
Z94209	Counter Clockwise Rotation - Round	1	1	1	1	1	1
Z94215	Frozen Battery Hazard	1	1	1	1	1	1
Z94228	Remove Ignition Key Caution	1	1	1	1	1	1
Z94235	150mm (6.0) Max Material Caution Decal	2	2	2	2	2	2
Z94247	CR Latch Label	1	1	1	1	1	1
Z94414	Roller Feed Chipper - Feed Control Rh	1	1	1	1	1	1
Z94416	CR100 Start Stop			1	1	1	1
Z94419	Roller Feed Chipper - Feed Control Lh	1	1	1	1	1	1
Z94422	Feed Control Lock	1	1	1	1	1	1
Z94423	CR70 Intell.Max.Rpm Instructions	1	1	1	1	1	1
Z94424	CR70 Rotor Lock	1	1	1	1	1	1
Z94426	Grease 50hrs Label	7	7	7	7	7	7
Z94435	Ulsd Label			1	1	1	1
Z94436	Antifreeze Label			1	1	1	1
Z94621	Protection Equipment	2	2	2	2	2	2
Z94621	Intellifeed	1	1	1	1	1	1
Z946217	Right Side Discharge Chute	1	1	1	1	1	1
Z946218	Left Side Discharge Chute	1	1	1	1	1	1
Z94651	CR70 L&R Chute Mid.Wallenstein	2	2	2	2	2	2

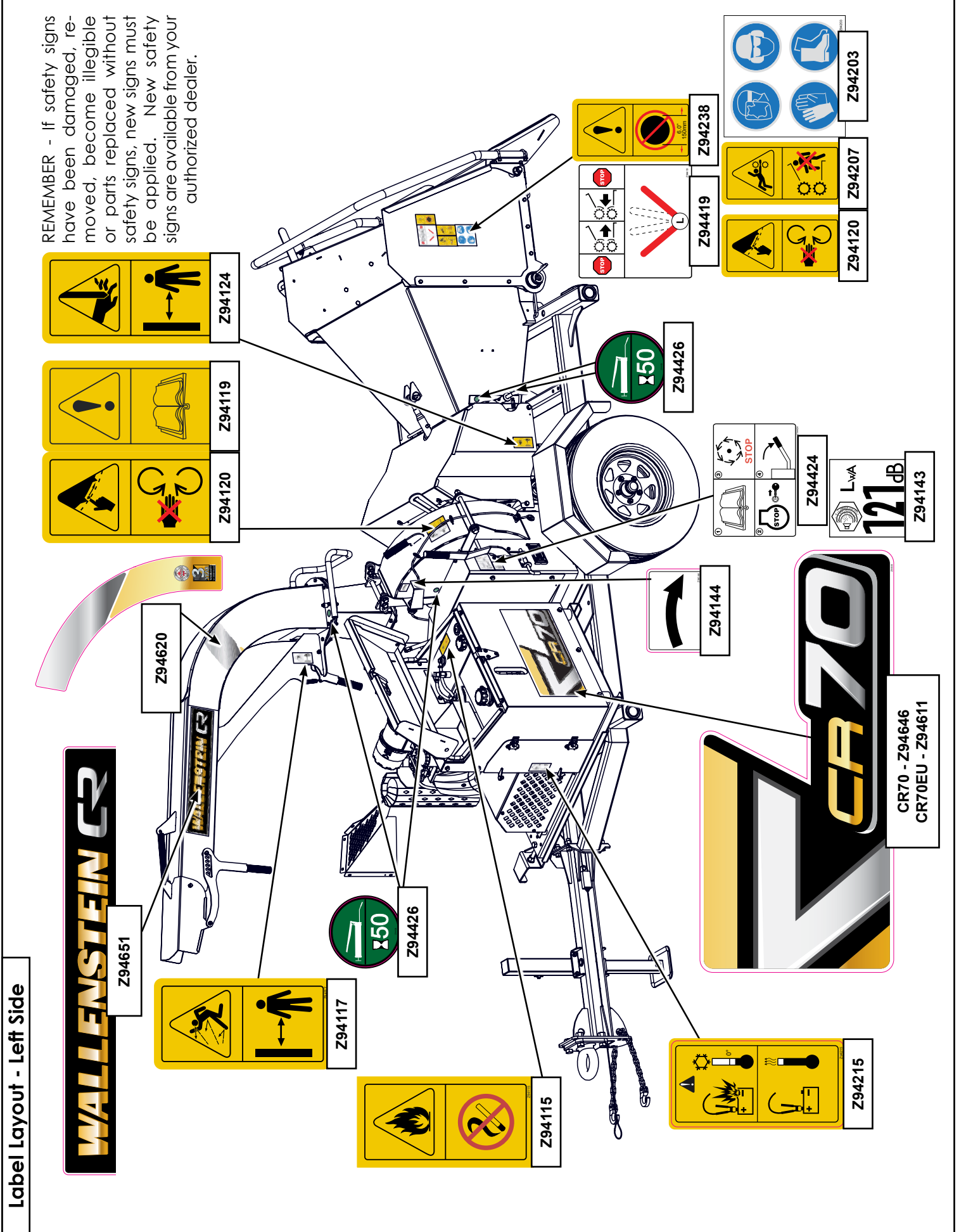

REMEMBER - If safety signs have been damaged, removed, become illegible or parts replaced without safety signs, new signs must be applied. New safety signs are available from your authorized dealer.

Label Layout - Left Side

WALLENSTEIN CR
Z94651

Z94117

Z94115

Z94426

Z94144

CR70
CR70 - Z94646
CR70EU - Z94611

Z94620

Z94120

Z94119

Z94124

Z94238

Z94207

Z94203

Z94426

Z94424

121 dB LWA
Z94143

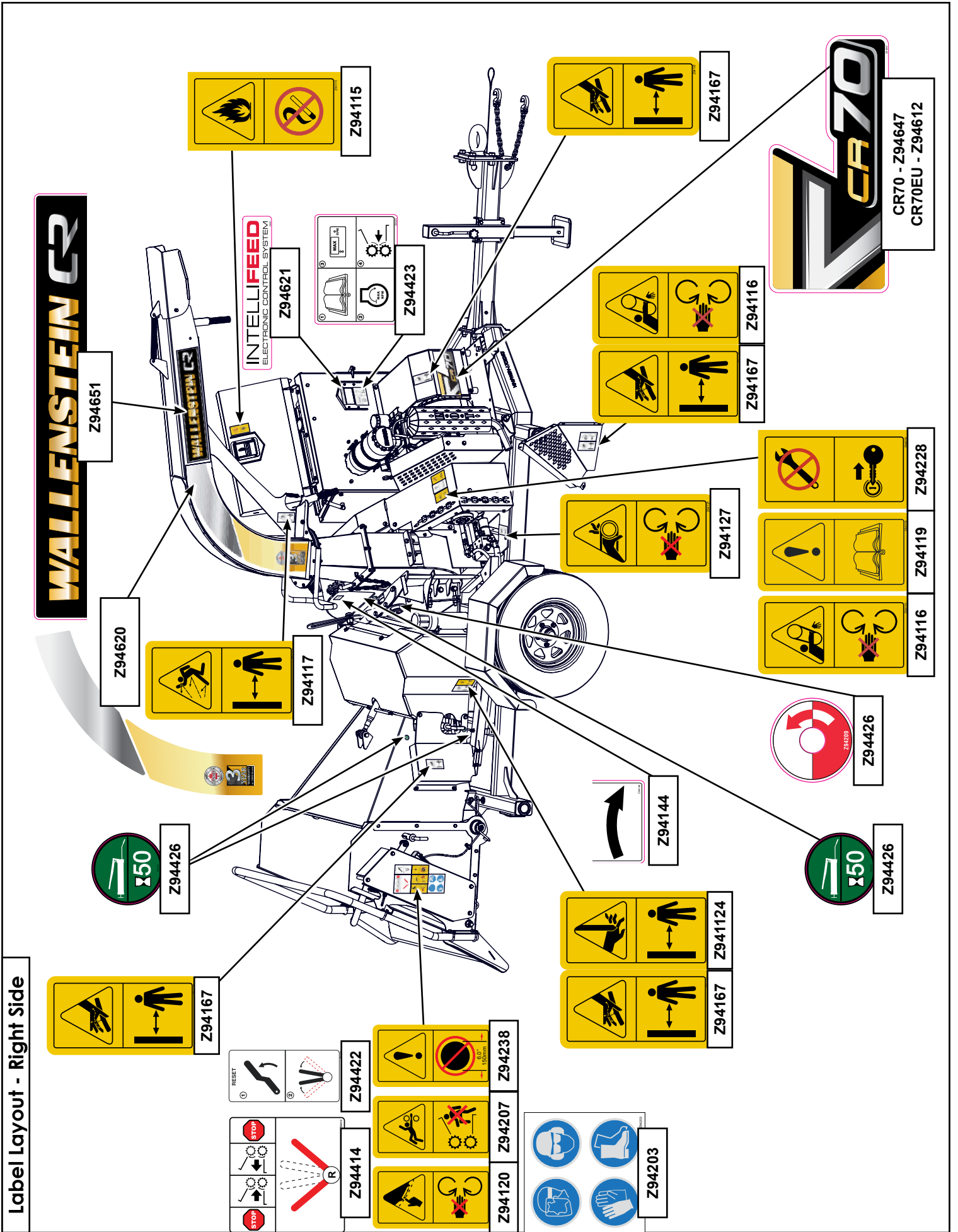

Label Layout - Right Side

Label Layout

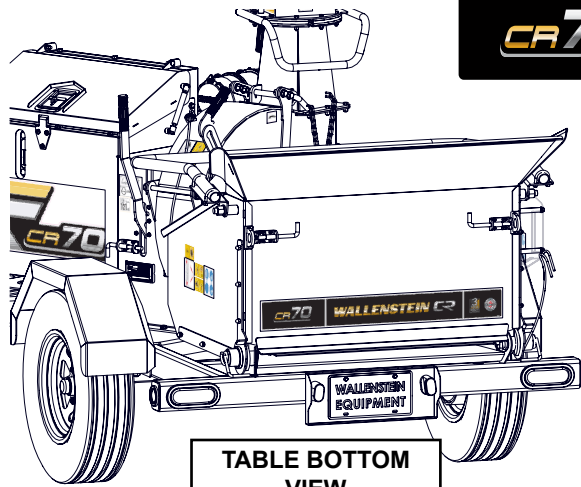

CR70 - Z946215
 CR70EU - Z946201

TABLE BOTTOM VIEW

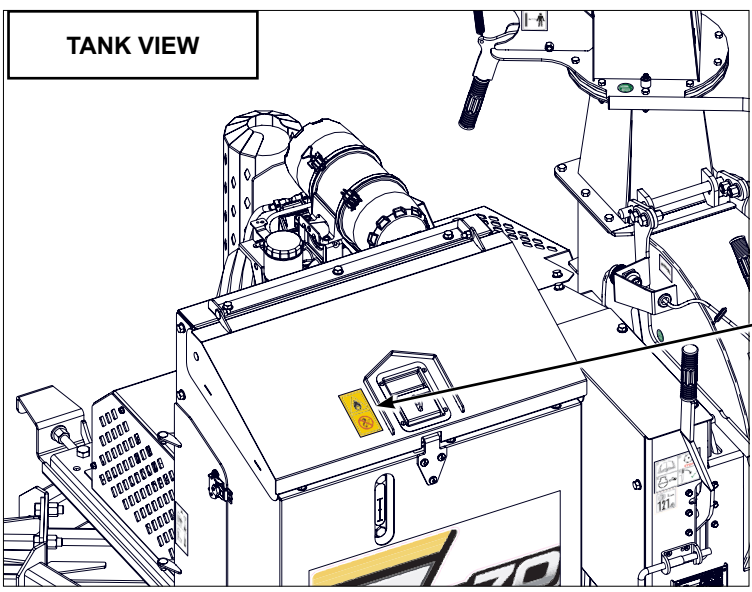

TANK VIEW

CLEAN OUT VIEW



Z94115

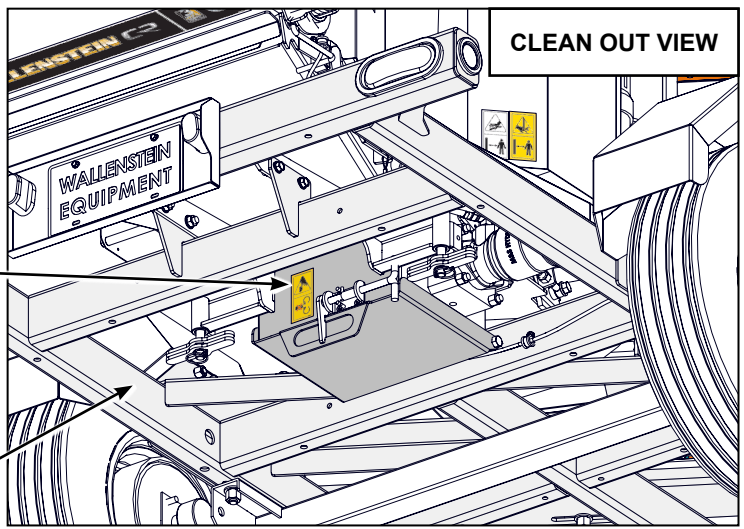

CLEAN OUT VIEW



Z94120

Accessories

#1012L269

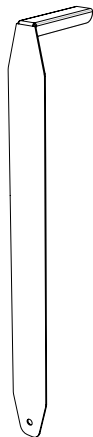

#1012L269 LEDGER CLEARANCE SETTING GAUGE

For **CR70 Series**

An easy and accurate way of setting the critical clearances between the ledger blade and the rotor chipper blade.



#Z97071 CR70 COMMERCIAL TRAILER WOOD CHIPPER OPERATOR'S MANUAL

Available as a download at
www.wallensteincr.com