



EMB Manufacturing Inc.
4144 Boomer Line · St. Clements, On · N0B 2M0 · Canada
Ph: (519) 699-9283 · Fax: (519) 699-4146
www.wallensteinequipment.com

GX920 Backhoe

Parts Manual

Starting with S/N's
3920685 and on

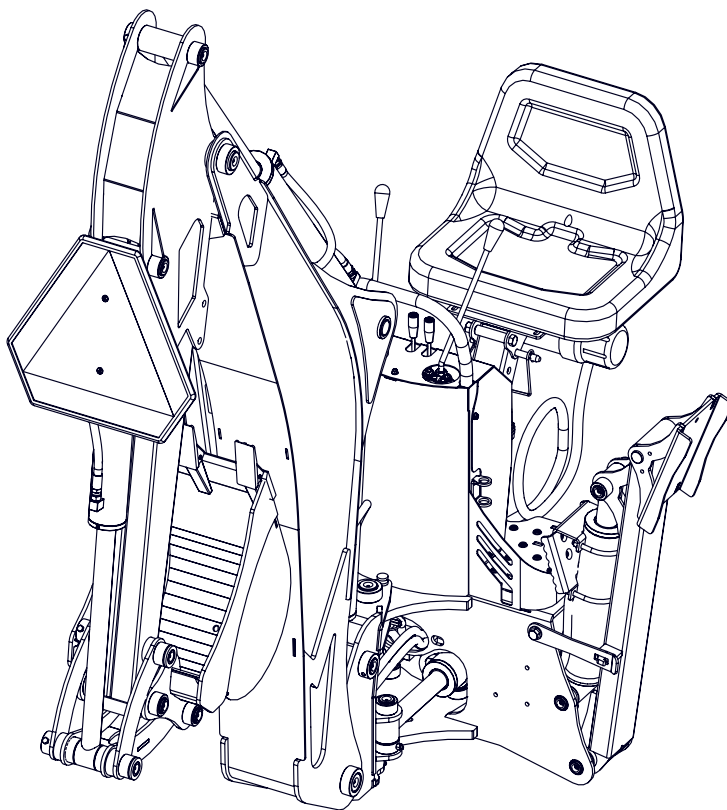

Refer to the operators
manual for safe
operation and
maintenance



3013T000 GX920 RevE1 Parts Manual.141215
Rev # 200617

Foreword

EMB Mfg. has prepared this parts manual to assist customers in ordering quality OEM replacement parts.

Proper and regular service and replacing old, worn or broken parts with the correct OEM parts are essential to prolonging the life of your EMB product. Please refer to this manual before ordering any replacement parts.

All information contained in this parts manual is based on the latest product specification available at the time of printing this manual. If your product differs from the specifications contained within this manual contact EMB Mfg. for information.

EMB reserves the right to alter specifications on their products at any time.

Reproduction of this parts manual of any kind is prohibited without prior written permission from EMB Mfg.

For parts and information please contact your dealer. If your dealer is no longer available please go to our website: <http://www.wallensteinequipment.com> and click on "FIND A DEALER NEAR YOU" for information on a local dealer.

Table of Contents Page

Bolt Torque.....	4
Hydraulic Fitting Torque	5
Main Frame Assembly	6
Stabilizer Leg Assembly	7
Main Boom Assembly	8
Dipper Boom Assembly	9
Bucket & Linkage Assembly.....	10
Seat Assembly	11
Swing Cylinder Assembly	12
Main Tower Cylinder Assembly.....	12
Stabilizer Cylinder Assembly	12
Dipper Boom Cylinder Assembly.....	12
Bucket Cylinder Assembly	13
Hydraulics & Valve Assemblies.....	13
Hydraulic Hose Schematics	14
Hydraulic Hose List	16
Label Layout.....	17
Label Layout - Grease Points	18
Accessories.....	19

Maintenance should be performed by
trained personnel only.



Refer to the operators
manual for safe
operation and
maintenance

Bolt Torque

CHECKING BOLT TORQUE

The tables shown below give correct torque values for various bolts and capscrews. Tighten all bolts to the torques specified in chart unless otherwise noted. Check tightness of bolts periodically, using bolt torque chart as a guide. Replace hardware with the same strength bolt.

ENGLISH TORQUE SPECIFICATIONS						
Bolt Diameter "A"	Bolt Torque*					
	SAE 2 (N.m) (lb-ft)		SAE 5 (N.m) (lb-ft)		SAE 8 (N.m) (lb-ft)	
1/4"	8	6	12	9	17	12
5/16"	13	10	25	19	36	27
3/8"	27	20	45	33	63	45
7/16"	41	30	72	53	100	75
1/2"	61	45	110	80	155	115
9/16"	95	60	155	115	220	165
5/8"	128	95	215	160	305	220
3/4"	225	165	390	290	540	400
7/8"	230	170	570	420	880	650
1"	345	225	850	630	1320	970

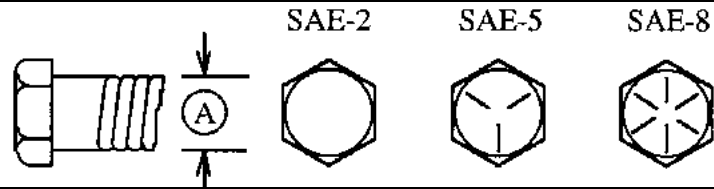

Torque figures indicated above are valid for non-greased or non-oiled threads and heads unless otherwise specified. Therefore, do not grease or oil bolts or capscrews unless otherwise specified in this manual. When using locking elements, increase torque values by 5%.

* Torque value for bolts and capscrews are identified by their head markings.

METRIC TORQUE SPECIFICATIONS				
Bolt Diameter "A"	Bolt Torque*			
	8.8 (N.m) (lb-ft)		10.9 (N.m) (lb-ft)	
M3	0.5	0.4	1.8	1.3
M4	3	2.2	4.5	3.3
M5	6	4	9	7
M6	10	7	15	11
M8	25	18	35	26
M10	50	37	70	52
M12	90	66	125	92
M14	140	103	200	148
M16	225	166	310	229
M20	435	321	610	450
M24	750	553	1050	774
M30	1495	1103	2100	1550
M36	2600	1917	3675	2710

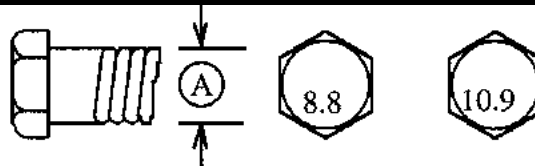

Hydraulic Fitting Torque**Tightening Flare Type Tube Fittings ***

1. Check flare and flare seat for defects that might cause leakage.
 2. Align tube with fitting before tightening.
 3. Lubricate connection and hand tighten swivel nut until snug.
 4. To prevent twisting the tube(s), use two wrenches. Place one wrench on the connector body and with the second tighten the swivel nut to the torque shown.
- The torque values shown are based on lubricated connections as in reassembly.

HYDRAULIC FITTING TORQUE					
Tube Size OD	Nut Size Across Flats	Torque Value*		Recommended Turns To Tighten (After Finger Tightening)	
		(N.m)	(lb-ft)	(Flats)	(Turn)
(in.)	(in.)				
3/16	7/16	8	6	1	1/6
1/4	9/16	12	9	1	1/6
5/16	5/8	16	12	1	1/6
3/8	11/16	24	18	1	1/6
1/2	7/8	46	34	1	1/6
5/8	1	62	46	1	1/6
3/4	1-1/4	102	75	3/4	1/8
7/8	1-3/8	122	90	3/4	1/8

Main Frame Assembly

BOM ID	Part No.	Description	Qty
1	3012W250	Base, Main Frame	1
2	Z11121	Toplink Pin, 3/4" x 2-3/4"	1
3	Z12140	Lynch Pin, 7/16"	1
4	Z27221	Connex Bushing 1 ID x 1-1/4 OD x 1-1/2 long x 1/8 wall	4
5	Z27241	Connex Bushing 1-1/2 x 1-3/4	2
6	Z11517	Hex Bolt, 1/2NC x 1-3/4"	4
7	Z12251	Hex Lock Nut, 1/2NC	4
8	Z12221	Hex Lock Nut, 5/16NC	5
9	Z16113	Flange Bolt, 1/4NC x 3/8"	7
10	Z94152	GX Backhoe Operation Decal	1
11	3012C203	Cylinder, 2-1/2 x 7-3/4 Stroke	2
12	3012W252	Bar, Swing Cylinder Retaining	1
13	3011L204	Shield, Control Valve	1
14	Z29202	Grease Zerk 1/4NF	2
15	Z29203	Grease Zerk 90, 1/4NF	2
16	Z11225	Hex Bolt, 5/16NC x 2-1/2"	2

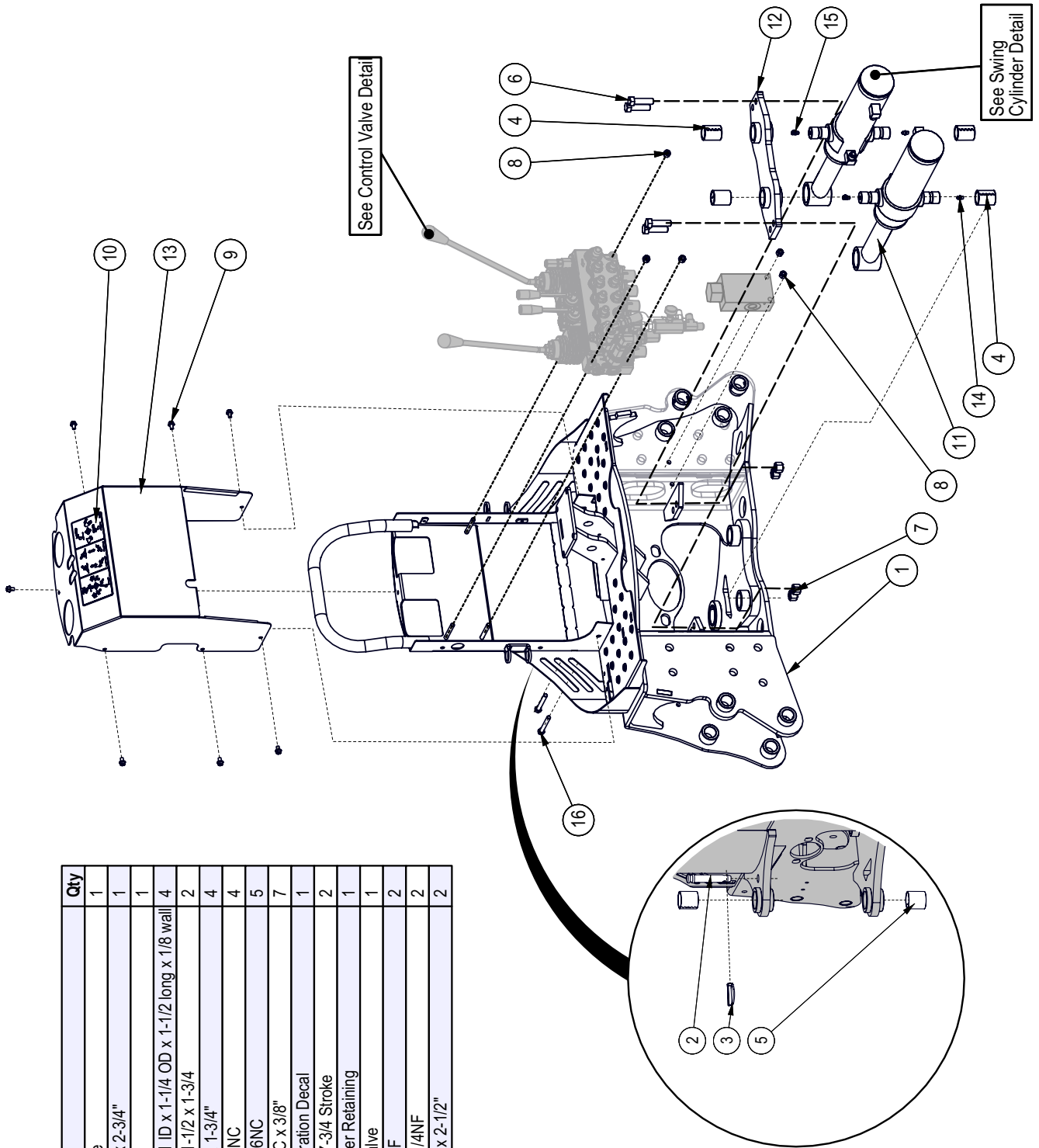

Stabilizer Leg Assembly

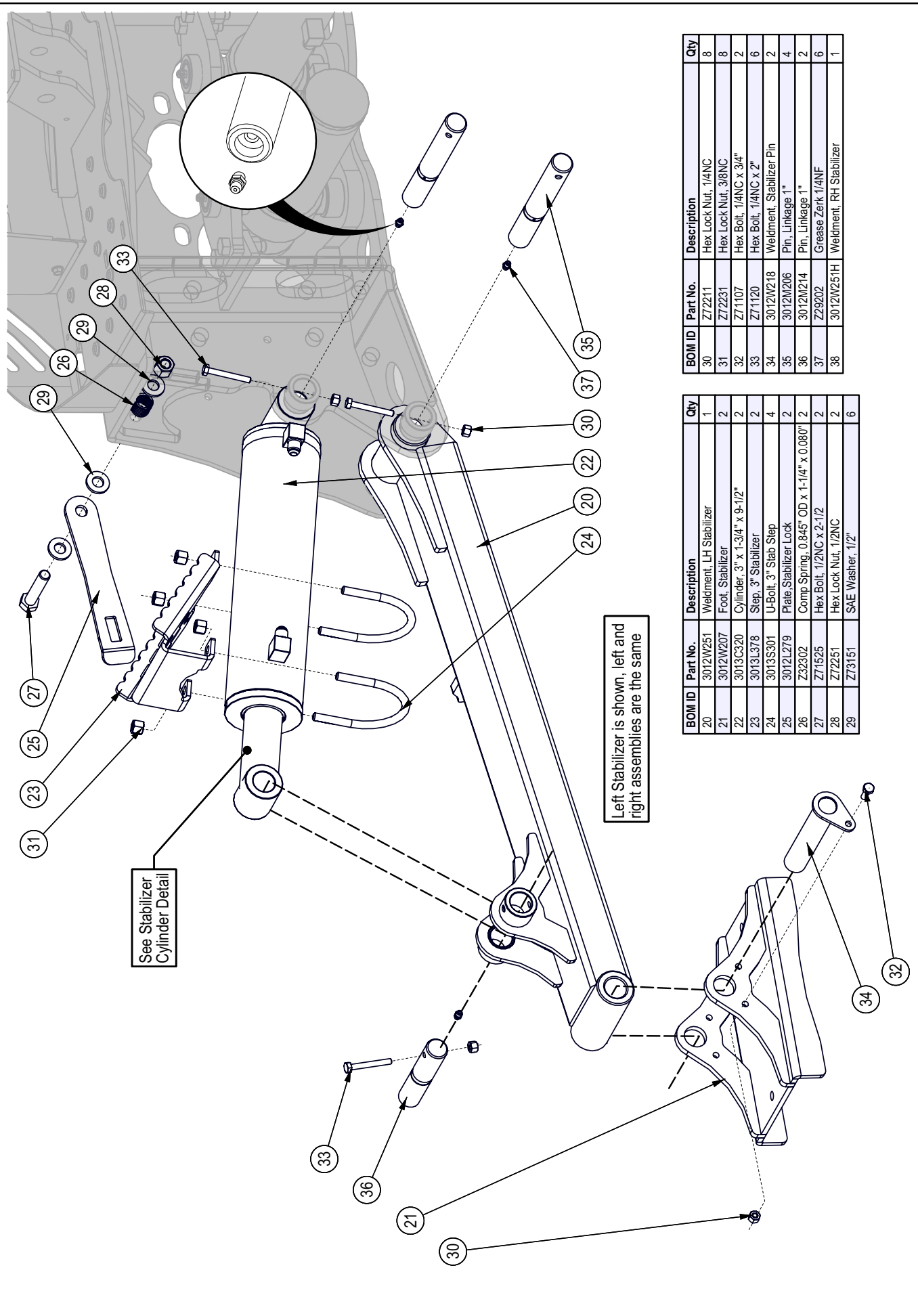

See Stabilizer
Cylinder Detail

Left Stabilizer is shown, left and
right assemblies are the same

BOM ID	Part No.	Description	Qty
20	3012W251	Weldment, LH Stabilizer	1
21	3012W207	Foot, Stabilizer	2
22	3013C320	Cylinder, 3" x 1-3/4" x 9-1/2"	2
23	3013L378	Step, 3" Stabilizer	2
24	3013S301	U-Bolt, 3" Stab Step	4
25	3012L279	Plate, Stabilizer Lock	2
26	Z32302	Comp Spring, 0.845" OD x 1-1/4" x 0.080"	2
27	Z71525	Hex Bolt, 1/2NC x 2-1/2	2
28	Z72251	Hex Lock Nut, 1/2NC	2
29	Z73151	SAE Washer, 1/2"	6

BOM ID	Part No.	Description	Qty
30	Z72211	Hex Lock Nut, 1/4NC	8
31	Z72231	Hex Lock Nut, 3/8NC	8
32	Z71107	Hex Bolt, 1/4NC x 3/4"	2
33	Z71120	Hex Bolt, 1/4NC x 2"	6
34	3012W218	Weldment, Stabilizer Pin	2
35	3012M206	Pin, Linkage 1"	4
36	3012M214	Pin, Linkage 1"	2
37	Z29202	Grease Zerk, 1/4NF	6
38	3012W251H	Weldment, RH Stabilizer	1

Main Boom Assembly

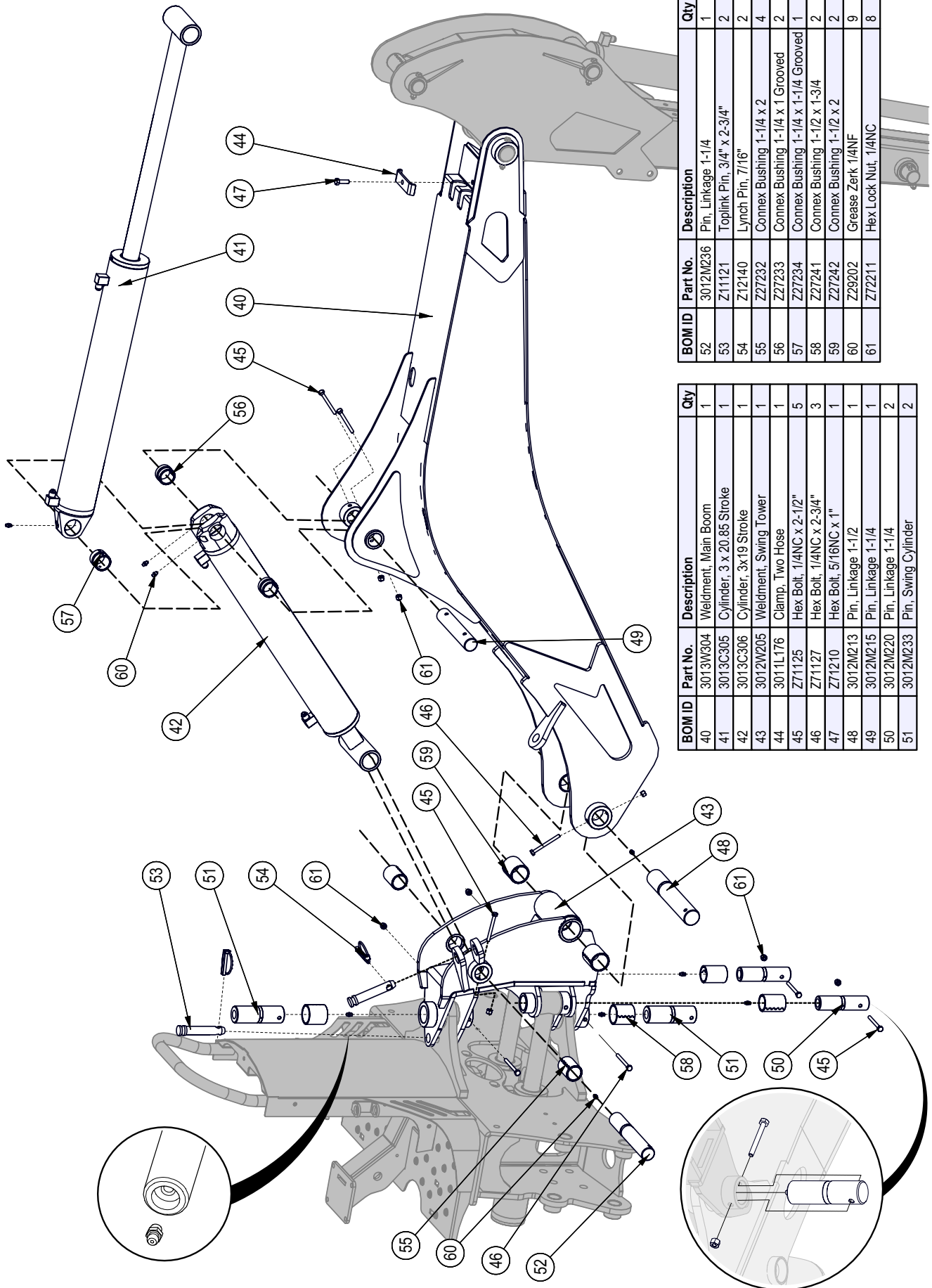

BOM ID	Part No.	Description	Qty
52	3012M236	Pin, Linkage 1-1/4	1
53	Z11121	Toplink Pin, 3/4" x 2-3/4"	2
54	Z12140	Lynch Pin, 7/16"	2
55	Z27232	Connex Bushing 1-1/4 x 2	4
56	Z27233	Connex Bushing 1-1/4 x 1 Grooved	2
57	Z27234	Connex Bushing 1-1/4 x 1-1/4 Grooved	1
58	Z27241	Connex Bushing 1-1/2 x 1-3/4	2
59	Z27242	Connex Bushing 1-1/2 x 2	2
60	Z29202	Grease Zerk 1/4NF	9
61	Z72211	Hex Lock Nut, 1/4NC	8

BOM ID	Part No.	Description	Qty
40	3013W304	Weldment, Main Boom	1
41	3013C305	Cylinder, 3 x 20.85 Stroke	1
42	3013C306	Cylinder, 3x19 Stroke	1
43	3012W205	Weldment, Swing Tower	1
44	3011L176	Clamp, Two Hose	1
45	Z71125	Hex Bolt, 1/4NC x 2-1/2"	5
46	Z71127	Hex Bolt, 1/4NC x 2-3/4"	3
47	Z71210	Hex Bolt, 5/16NC x 1"	1
48	3012M213	Pin, Linkage 1-1/2	1
49	3012M215	Pin, Linkage 1-1/4	1
50	3012M220	Pin, Linkage 1-1/4	2
51	3012M233	Pin, Swing Cylinder	2

Dipper Boom Assembly

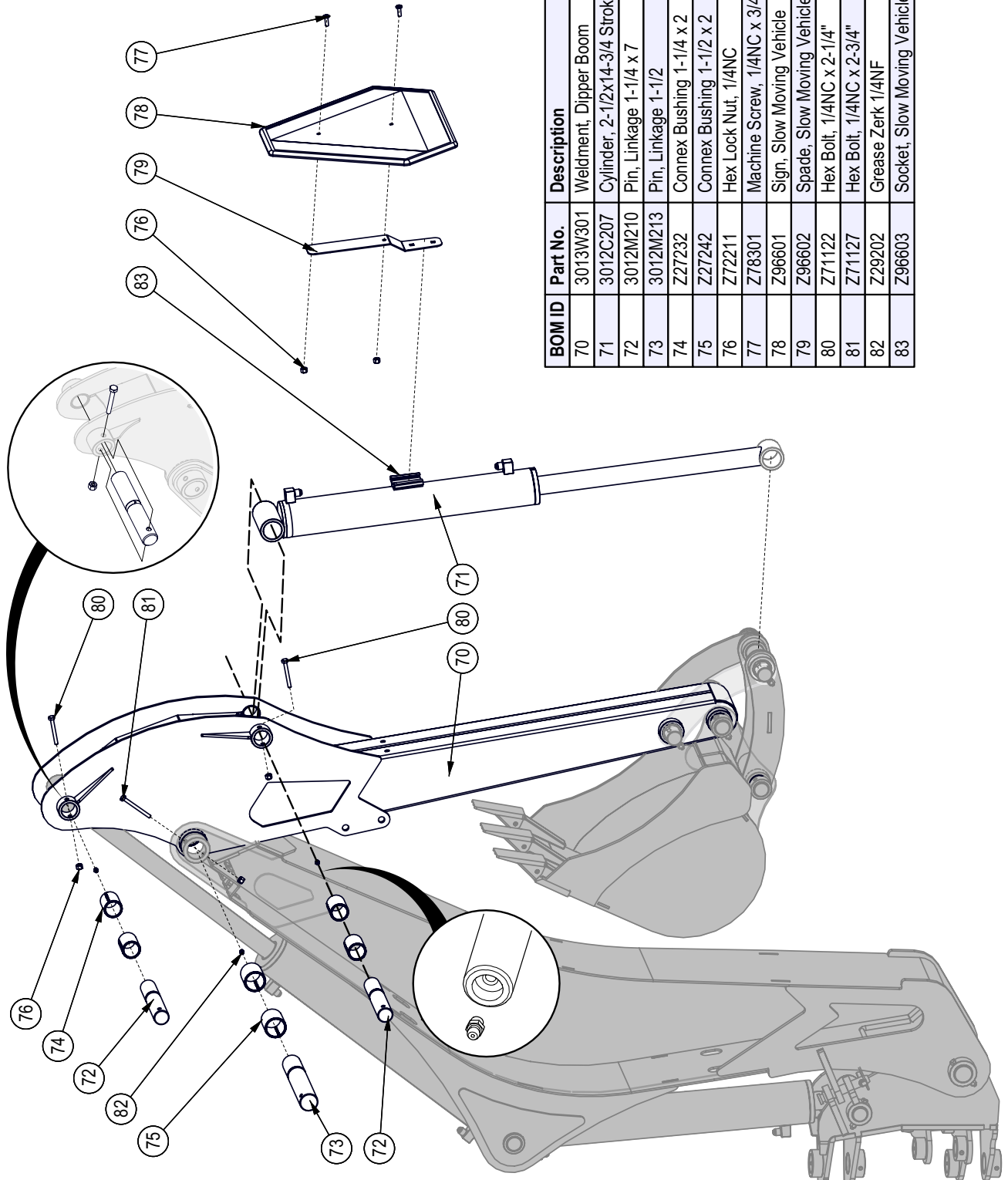

BOM ID	Part No.	Description	Qty
70	3013W301	Weldment, Dipper Boom	1
71	3012C207	Cylinder, 2-1/2x14-3/4 Stroke	1
72	3012M210	Pin, Linkage 1-1/4 x 7	2
73	3012M213	Pin, Linkage 1-1/2	1
74	Z27232	Connex Bushing 1-1/4 x 2	4
75	Z27242	Connex Bushing 1-1/2 x 2	2
76	Z72211	Hex Lock Nut, 1/4NC	5
77	Z78301	Machine Screw, 1/4NC x 3/4"	2
78	Z96601	Sign, Slow Moving Vehicle	1
79	Z96602	Spade, Slow Moving Vehicle	1
80	Z71122	Hex Bolt, 1/4NC x 2-1/4"	2
81	Z71127	Hex Bolt, 1/4NC x 2-3/4"	1
82	Z29202	Grease Zerker 1/4NF	3
83	Z96603	Socket, Slow Moving Vehicle	1

Bucket & Linkage Assembly

BOM ID	Part No.	Description	Qty
90	3012M209	Pin, Linkage 1-1/4 x 8-3/8	2
91	3012W202	Weldment, RH Bucket Linkage	1
92	3012W203	Weldment, Middle Bucket Linkage	1
93	3012W217	Bucket Pin w/ Washer	2
94	3012W220	Weldment, LH Bucket Linkage	1
95	3082W051	Weldment, GX720 12" Backhoe Bucket	1
96	Z14181	Roll Pin, 5/16" x 1-1/2"	3
97	Z19902	Tooth, Backhoe Pin-on	3
98	Z29202	Grease Zerk 1/4NF	4
99	Z71122	Hex Bolt, 1/4NC x 2-1/4"	4
100	Z72211	Hex Lock Nut, 1/4NC	4
101	Z27232	Connex Bushing 1-1/4 x 2	6
102	Z27231	Connex Bushing 1-1/4 x 1-3/4	3

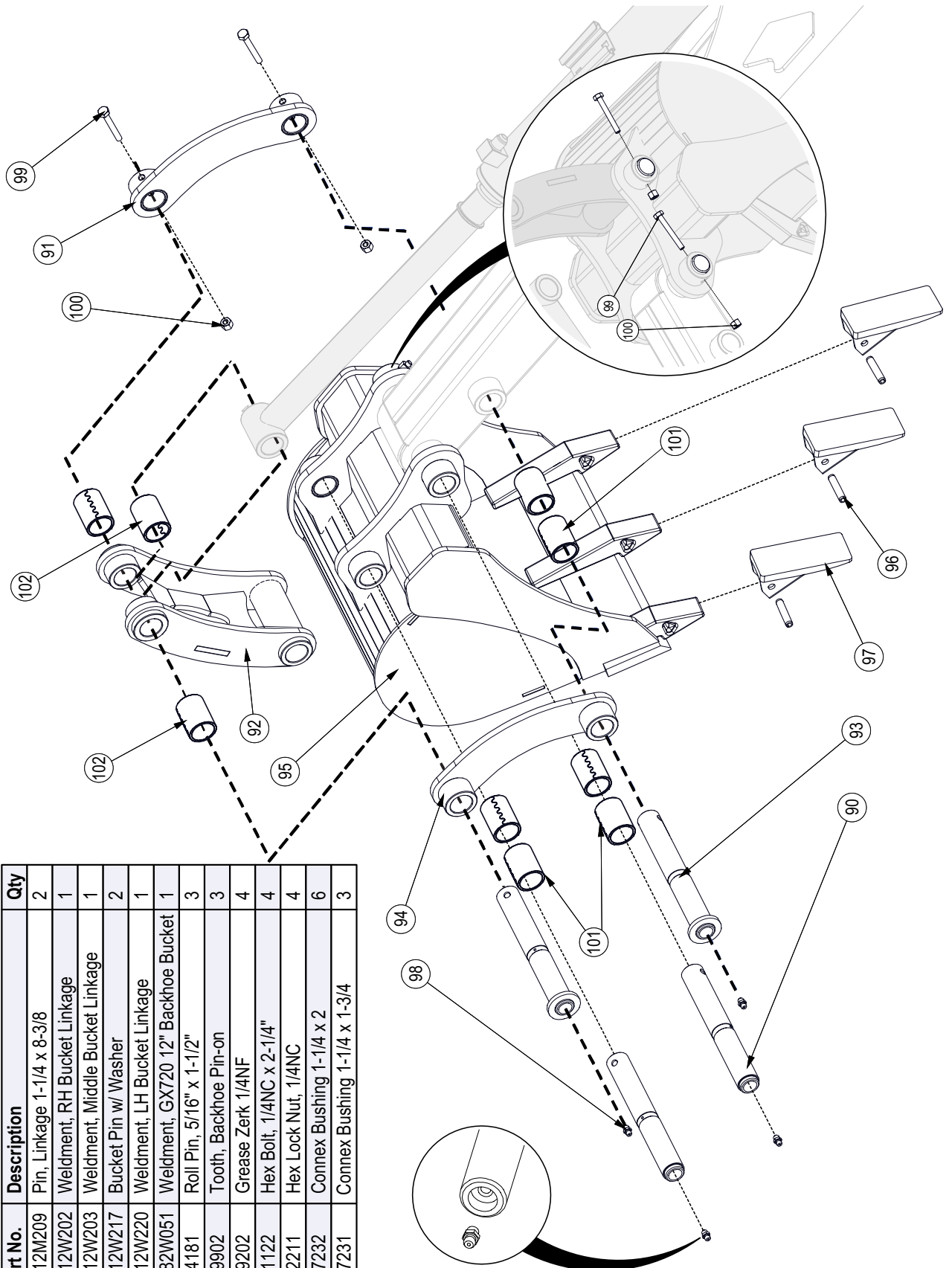

Seat Assembly

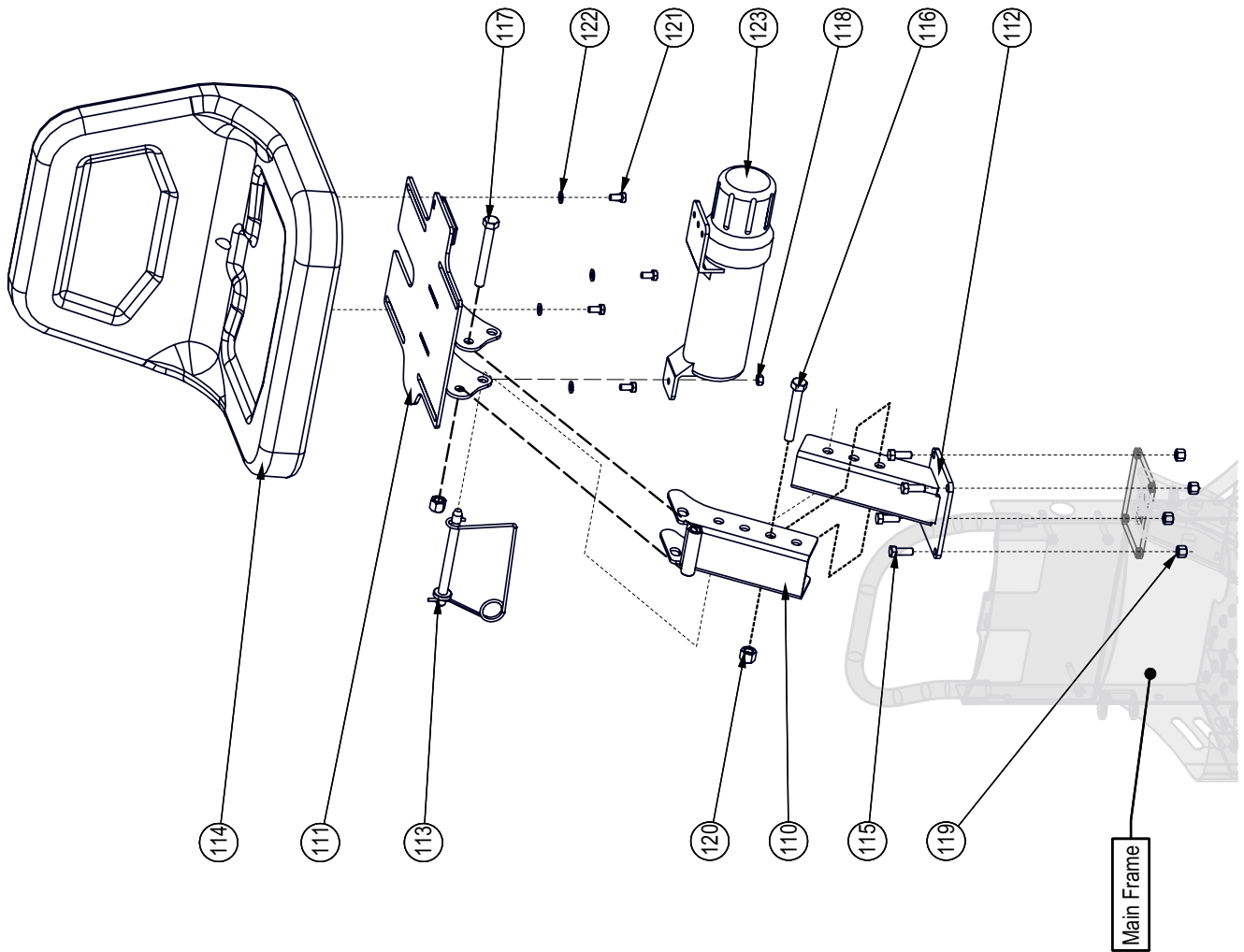

BOM ID	Part No.	Description	Qty
110	3011W112	Mount, Seat	1
111	3011W113	Plate, Seat	1
112	3011W111	Base, Seat	1
113	Z12441	Snap Lock Pin, 1/2" x 4-1/2"	1
114	Z19201	High-Back Backhoe Seat	1
115	Z71310	Hex Bolt, 3/8NC x 1"	4
116	Z71535	Hex Bolt, 1/2NC x 3-1/2"	1
117	Z71540	Hex Bolt, 1/2NC x 4"	1
118	Z72121	Hex Nut, 5/16NC	1
119	Z72231	Hex Lock Nut, 3/8NC	4
120	Z72251	Hex Lock Nut, 1/2NC	2
121	Z77152	Hex Bolt, M8x1.25 x 16mm	4
122	Z77352	DIN 125 Washer, M8	4
123	Z96503	Manual Tube, 3-1/2" Short	1

Swing Cylinder Assembly

Seal Kit #SLK-2515

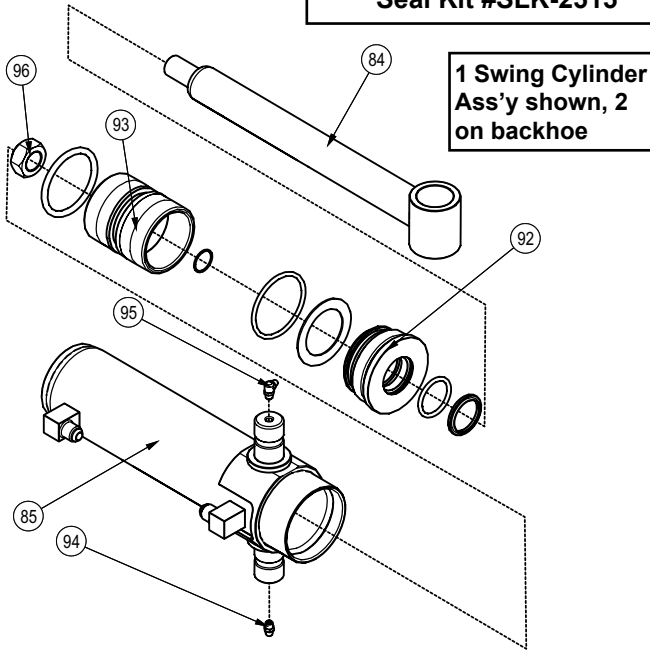

BOM ID	Part No.	Description	Qty
84	3012C2033	Rod, 1-1/2" x 1	1
85	3012C2034	Barrel, 2-1/2" Trunnion Mount	1
92	G250-150S	Gland, 2-1/2" x 1-1/2"	1
93	P100-250CP	Piston, 2-1/2" Bore x Cushion	1
94	Z29202	Grease Zerk 1/4NF	1
95	Z29203	Grease Zerk 90, 1/4NF	1
96	Z72276	Hex Thick Nut, 3/4NF	1

Stabilizer Cylinder Assembly

Seal Kit #SLK-3017

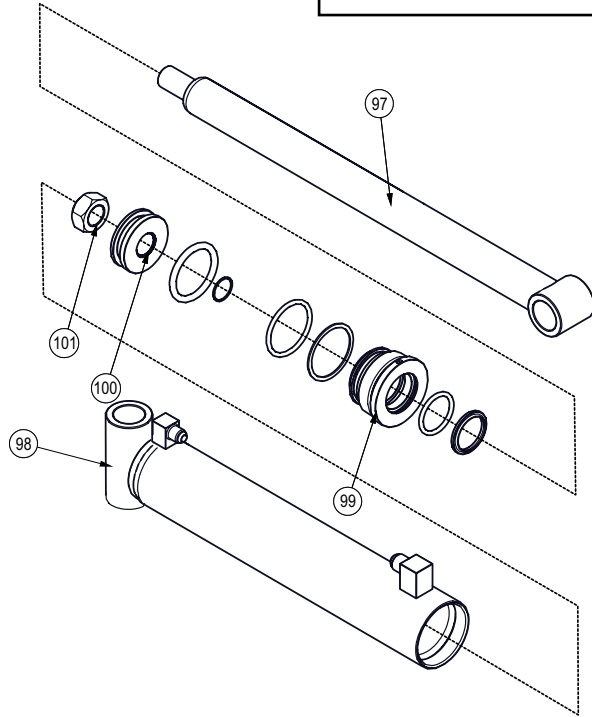

BOM ID	Part No.	Description	Qty
97	3013C3203	Rod, 1-3/4" x 1"	1
98	3013C3204	Barrel, 3"	1
99	G300-175S	Gland, 3" x 1-3/4"	1
100	P100-300SP	Piston, 3" Bore	1
101	Z72292G8	Hex Lock Nut, 1-1/4NF G8	1

Main Tower Cylinder Assembly

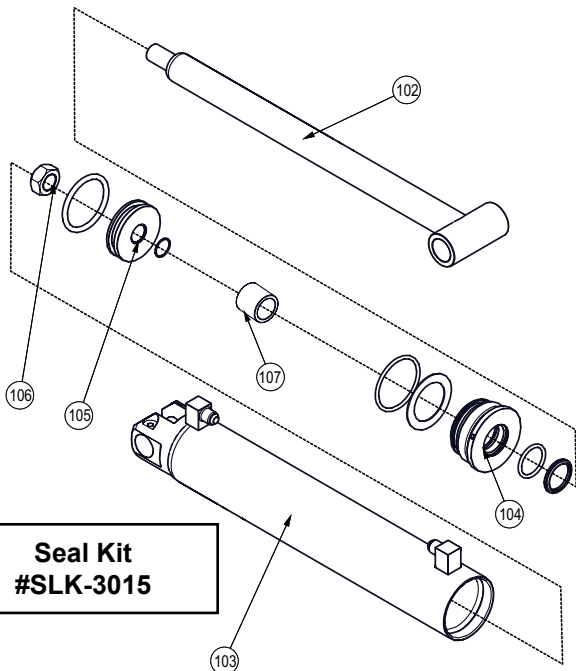

BOM ID	Part No.	Description	Qty
102	3013C3063	Rod, 1-1/2" x 1NF	1
103	3013C3064	Barrel, 3"	1
104	G300-150S	Gland, 3" x 1-1/2"	1
105	P100-300SP	Piston, 3" Bore	1
106	Z72276	Hex Top-lock Nut, 3/4NF	1
107	3013C3067	Internal Stroke Stop	1

Dipper Boom Cylinder Assembly

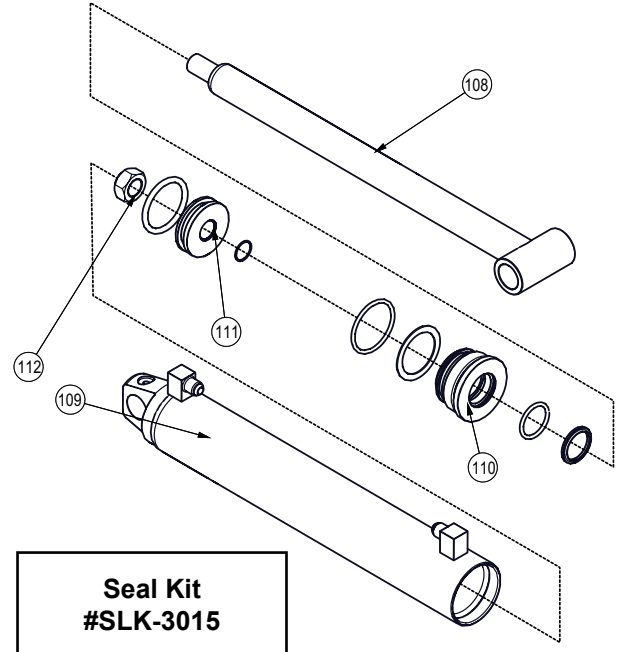

BOM ID	Part No.	Description	Qty
108	3013C3053	Rod, 1-1/2" x 1NF	1
109	3013C3054	Barrel, 3"	1
110	G300-150S	Gland, 3" x 1-1/2"	1
111	P100-300SP	Piston, 3" Bore	1
112	Z72276	Hex Top-lock Nut, 3/4NF	1

Bucket Cylinder Assembly

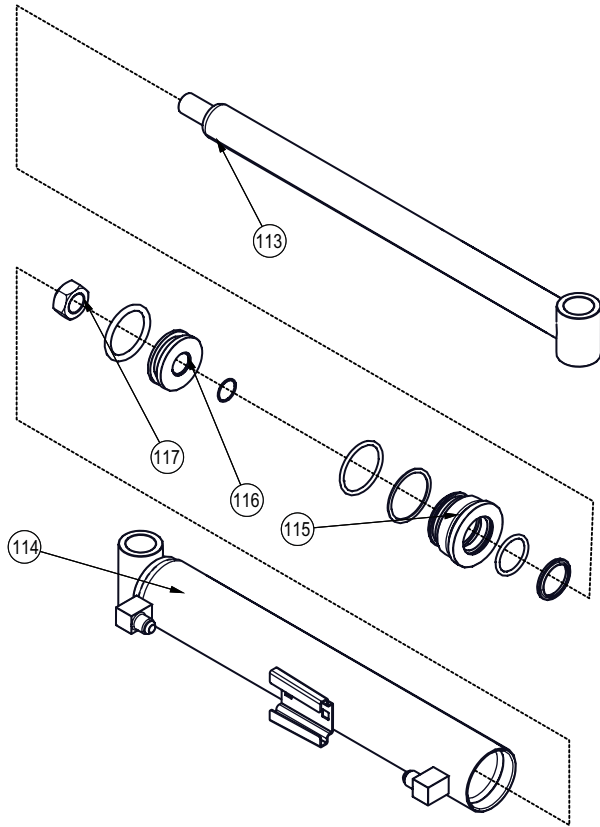

**Seal Kit
#SLK-2515**

BOM ID	Part No.	Description	Qty
113	3012C2073	Rod, 1-1/2" x 1NF	1
114	3012C2074	Barrel, 2-1/2" Bore	1
115	G250-150S	Gland, 2-1/2" x 1-1/2"	1
116	P100-250SP	Piston, 2-1/2" Bore	1
117	Z72276	Hex Top-lock Nut, 3/4NF	1

Hydraulics & Valve Assemblies

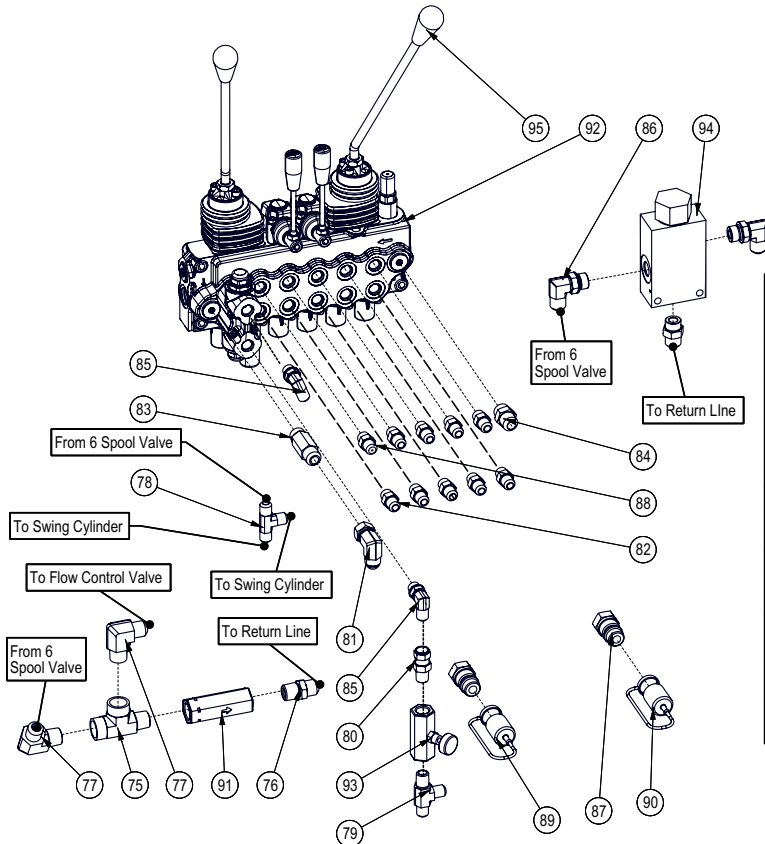

BOM ID	Part No.	Description	Qty
75	Z51172	Tee, MP x FP x FP 080808	1
76	Z51442	Straight, MJIC x MP 0808	1
77	Z51451	Elbow 90, MJIC x MP 0808	2
78	Z51483	Tee, MJIC x MJIC x MJIC 060606	1
79	Z51486	Tee, MJIC x MP x MJIC 060606	1
80	Z51511	Straight, MP x FJICX 0606	1
81	Z51562	Elbow 90, MJIC x FJICX 0808	1
82	Z51641	Straight, MJIC x MORB 0606	9
83	Z51642	Straight, MJIC x MORB 0808 Long Custom	1
84	Z51643	Straight, MJIC x MORB 0808	2
85	Z51651	Elbow 90, MJIC x MORB 0606	2
86	Z51653	Elbow 90, MJIC x MORB 0808	2
87	Z51926	Quick Coupler, FP08 x M ISO 7241-1	2
88	Z51928	Straight, MJIC x MORB 0606 x 0.062" Orifice	1
89	Z52831	Nipple Cap, ISO 7241-1 x Red	1
90	Z52832	Nipple Cap, ISO 7241-1 x Black	1
91	Z56102	Check Valve, FP08 x OPSI	1
92	Z56202	Six Spool Valve, VC x 12GPM	1
93	Z56301	Flow Control, Needle x 0-9GPM	1
94	Z56307	Flow Control, 3 Port x 7GPM	1
95	Z56910	Backhoe Lever Bent - 12"	2

Valve Service Parts

Part No.	Description
3CU1210133	1[S]/SD5 SPOOL
3CU1245620	5PY/SD5 SPOOL
3XTAP822150	TCEI SAE8 PLUG
4GUA115926	15.88X2.62 NBR 70 SH O-RING SEAL
XTAP623170	AET/SD5 PLUG
5V08105000	SPRING CENTER KIT
5V13405020	FLOAT KIT
LCN5(1-4)	LCB6 JOYSTICK KIT FUNCTION 1-4 Left (5CLO305100)
LCN5(2-3)	LCB6 JOYSTICK KIT FUNCTION 2-3 Right (5CLO305101)
5LEV105000	L5 LEVER BOX
602001101	PORT RELIEF BLOCK
5KIT105413	RELIEF VALVE

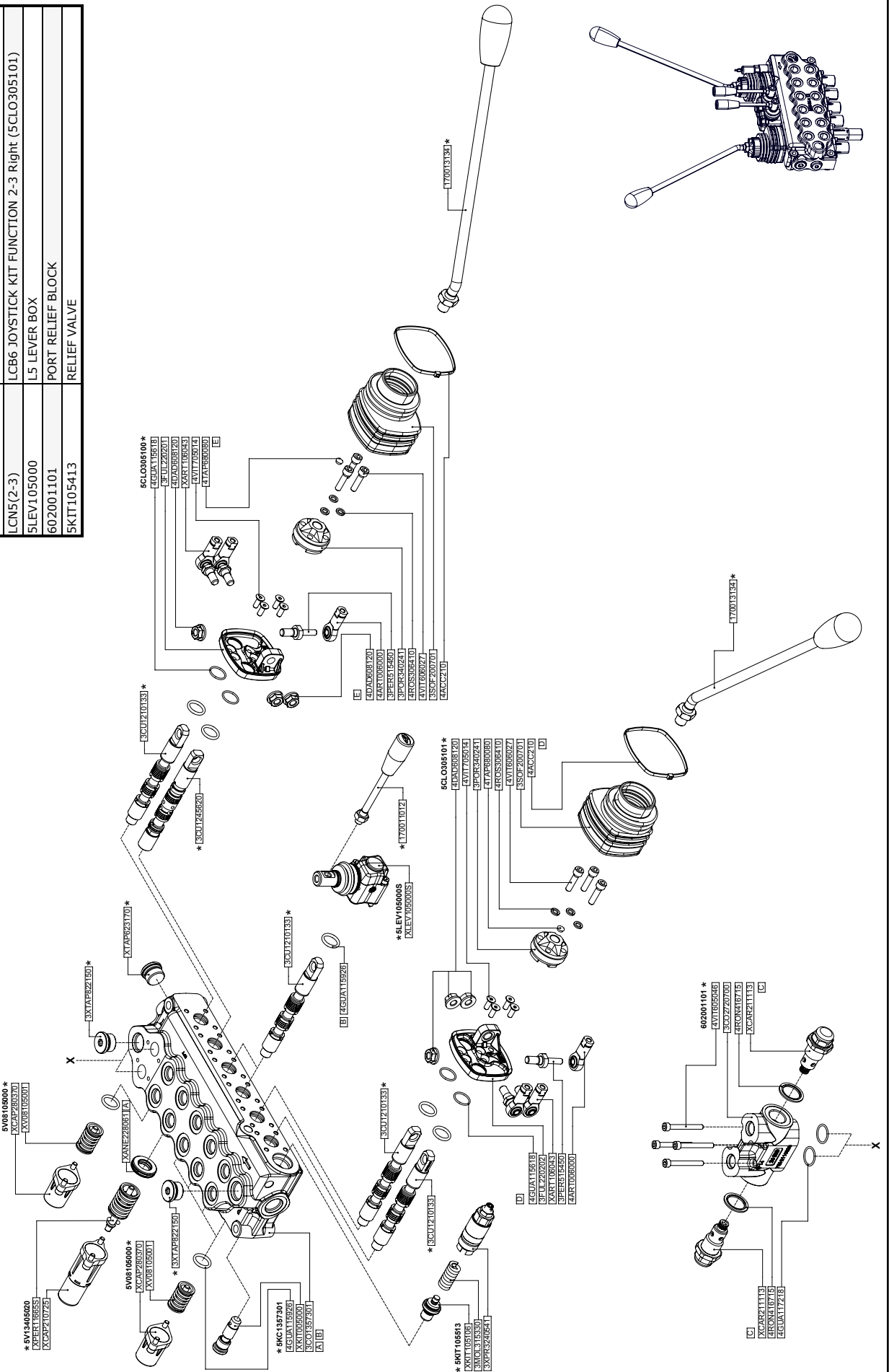

Hydraulic Hose Schematics

Open Center

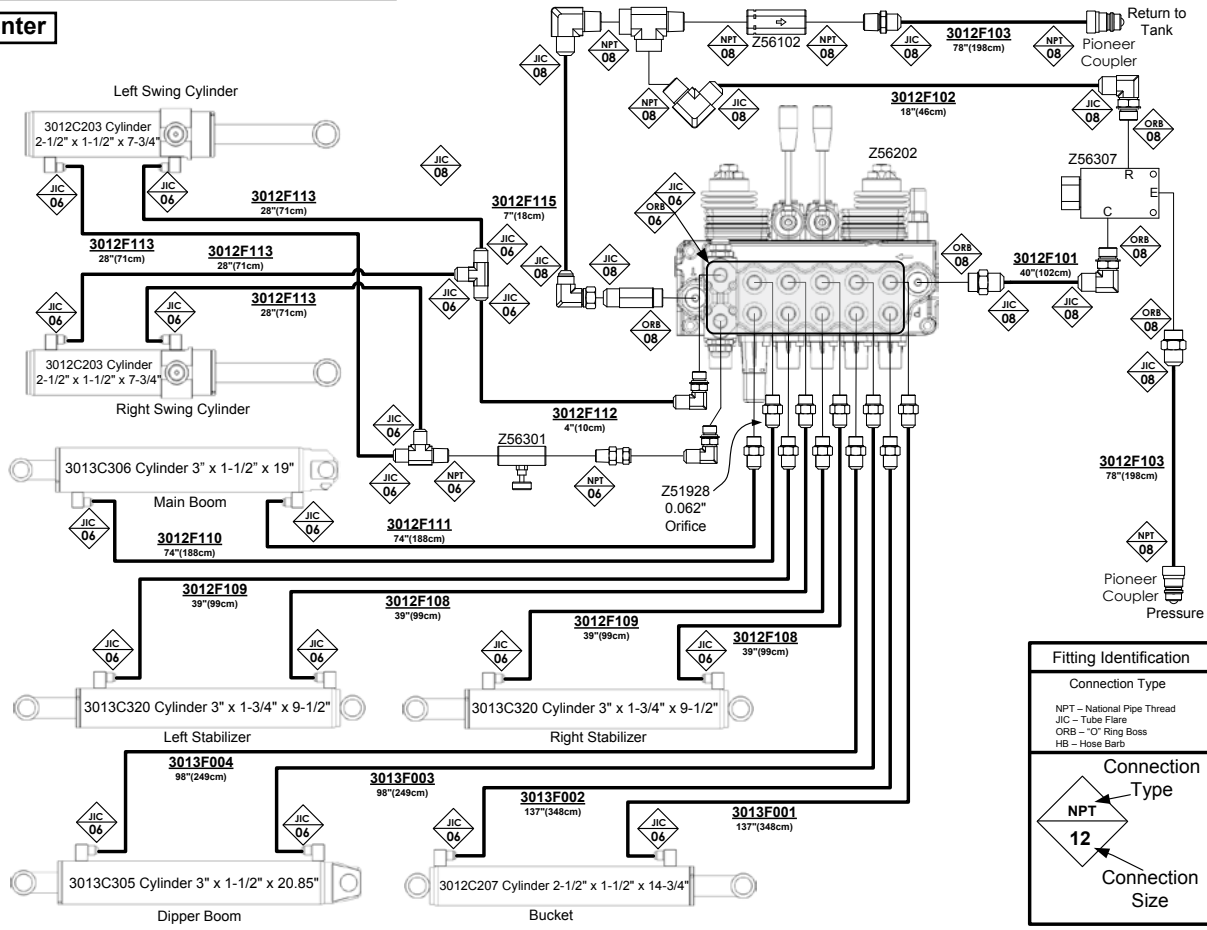

Fitting Identification	
Connection Type	
NPT	- National Pipe Thread
JIC	- Tube Flare
ORB	- O' Ring Boss
HB	- Hose Barb
Connection	
Type	
12	
Connection Size	

Open Center with Hydraulic Thumb

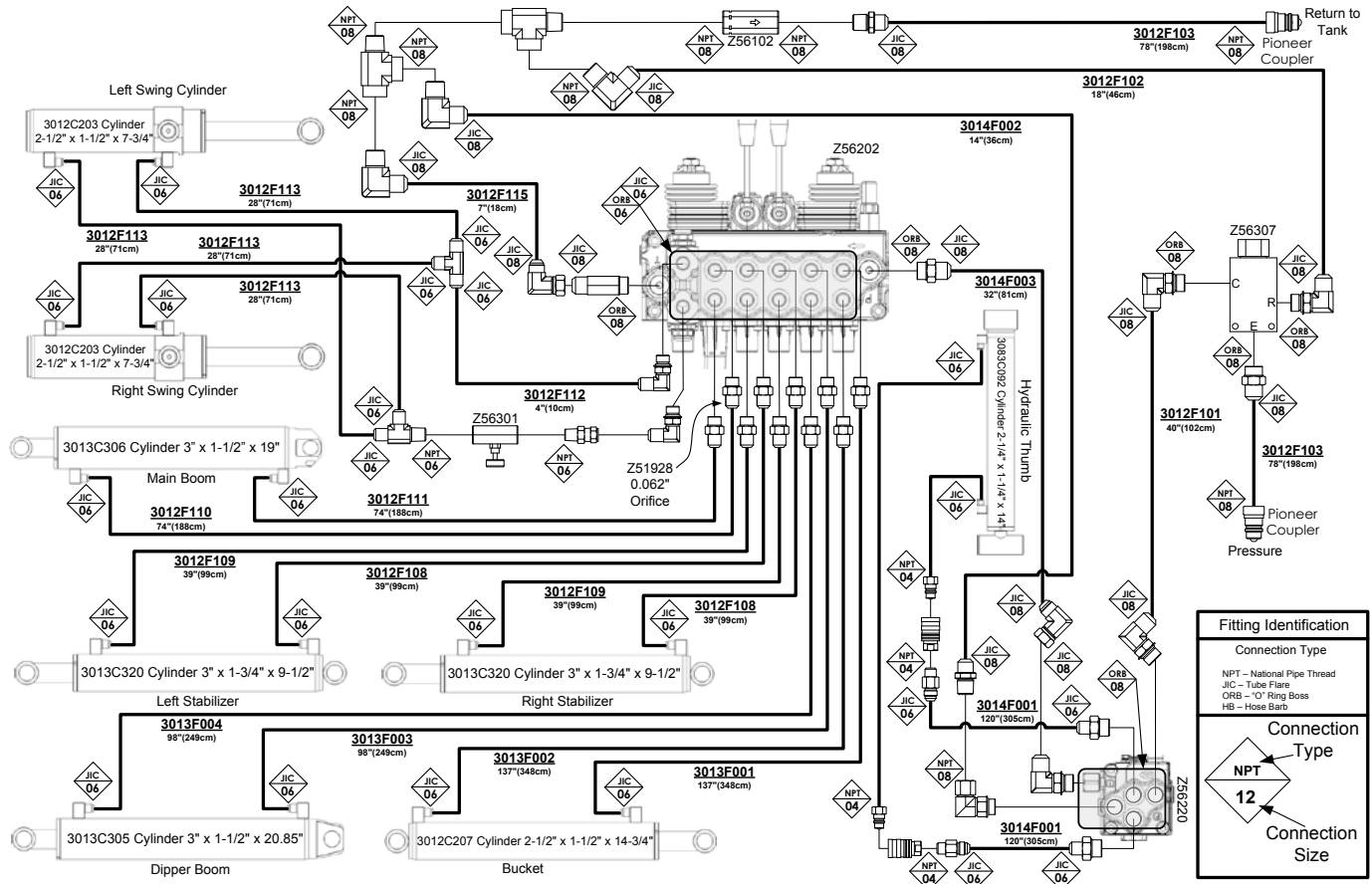

Fitting Identification	
Connection Type	
NPT	- National Pipe Thread
JIC	- Tube Flare
ORB	- O' Ring Boss
HB	- Hose Barb
Connection	
Type	
12	
Connection Size	

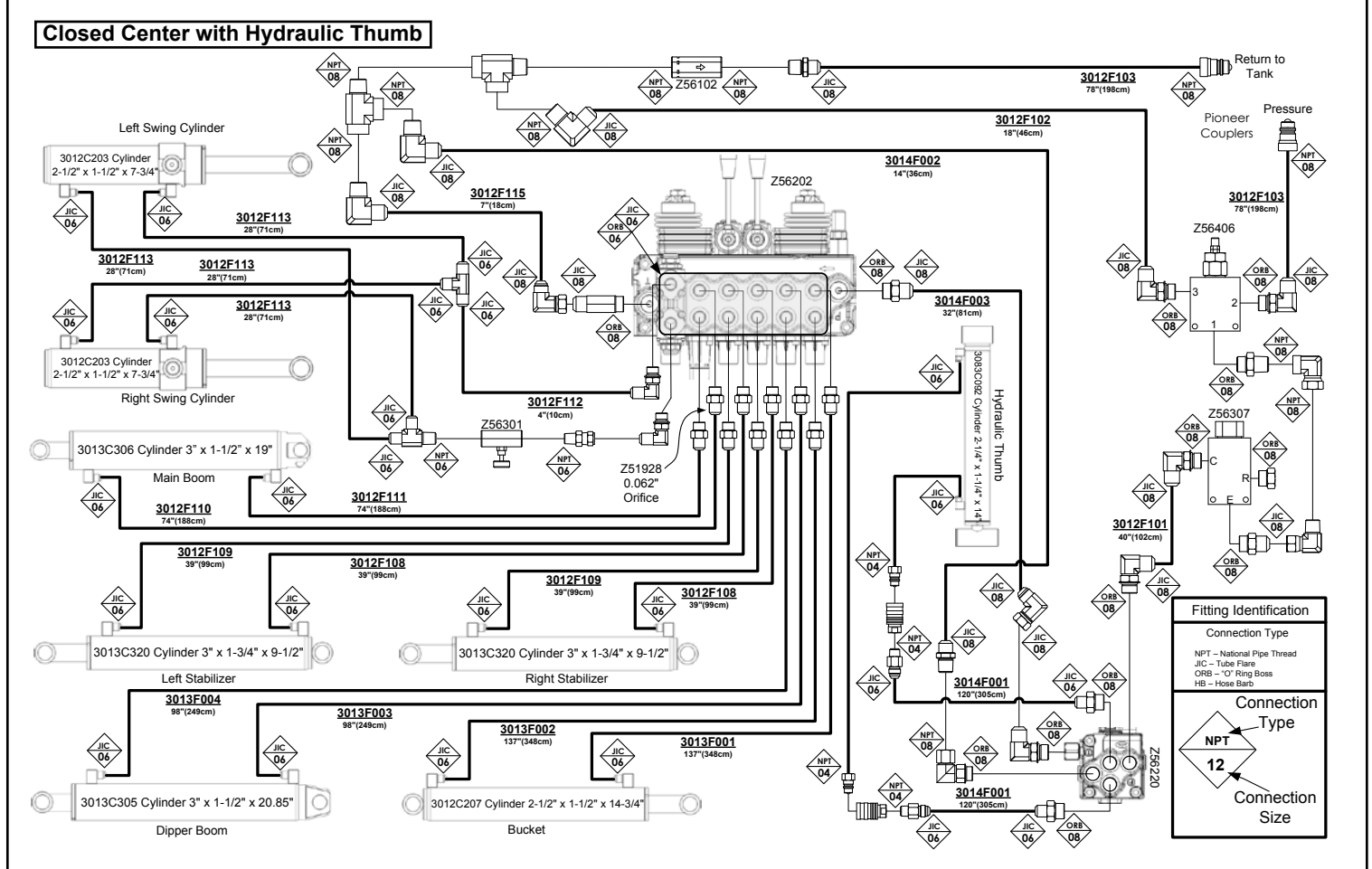
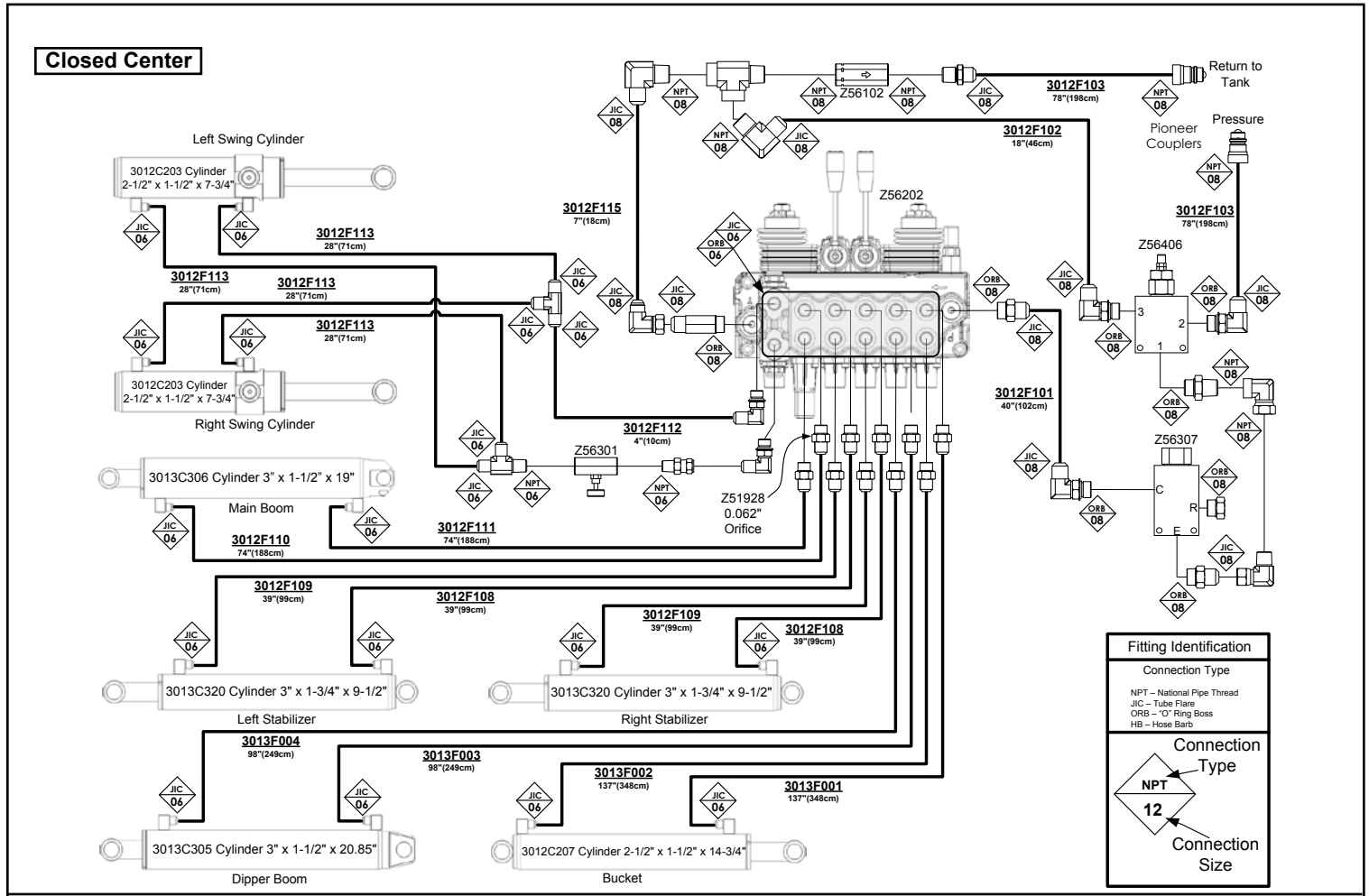

Hydraulic Hose List

Part No.	Description	Qty
3012F101	1/2" Hose, FJIC08 x FJIC08 x 34	1
3012F102	1/2" Hose, FJIC08 x FJIC08 x 18	1
3012F103	1/2" Hose, Long 90 FJIC08 x MP08 x 78	2
3012F108	3/8" Hose, FJIC06 x Long 90 FJIC06 x 39	2
3012F109	3/8" Hose, FJIC06 x 90 FJIC06 x 39	2
3012F110	3/8" Hose, FJIC06 x Long 90 FJIC06 x 74	1
3012F111	3/8" Hose, FJIC06 x 90 FJIC06 x 74	1
3012F112	3/8" Hose, FJIC06 x FJIC06 x 4	1
3012F113	1/4" Hose, FJIC06 x FJIC06 x 28	4
3012F115	1/2" Hose, FJIC08 x FJIC08 x 7	1
3013F001	3/8" Hose, FJIC06 x Long 90 FJIC06 x 137	1
3013F002	3/8" Hose, FJIC06 x 90 FJIC06 x 137	1
3013F003	3/8" Hose, FJIC06 x Long 90 FJIC06 x 98	1
3013F004	3/8" Hose, FJIC06 x 90 FJIC06 x 98	1

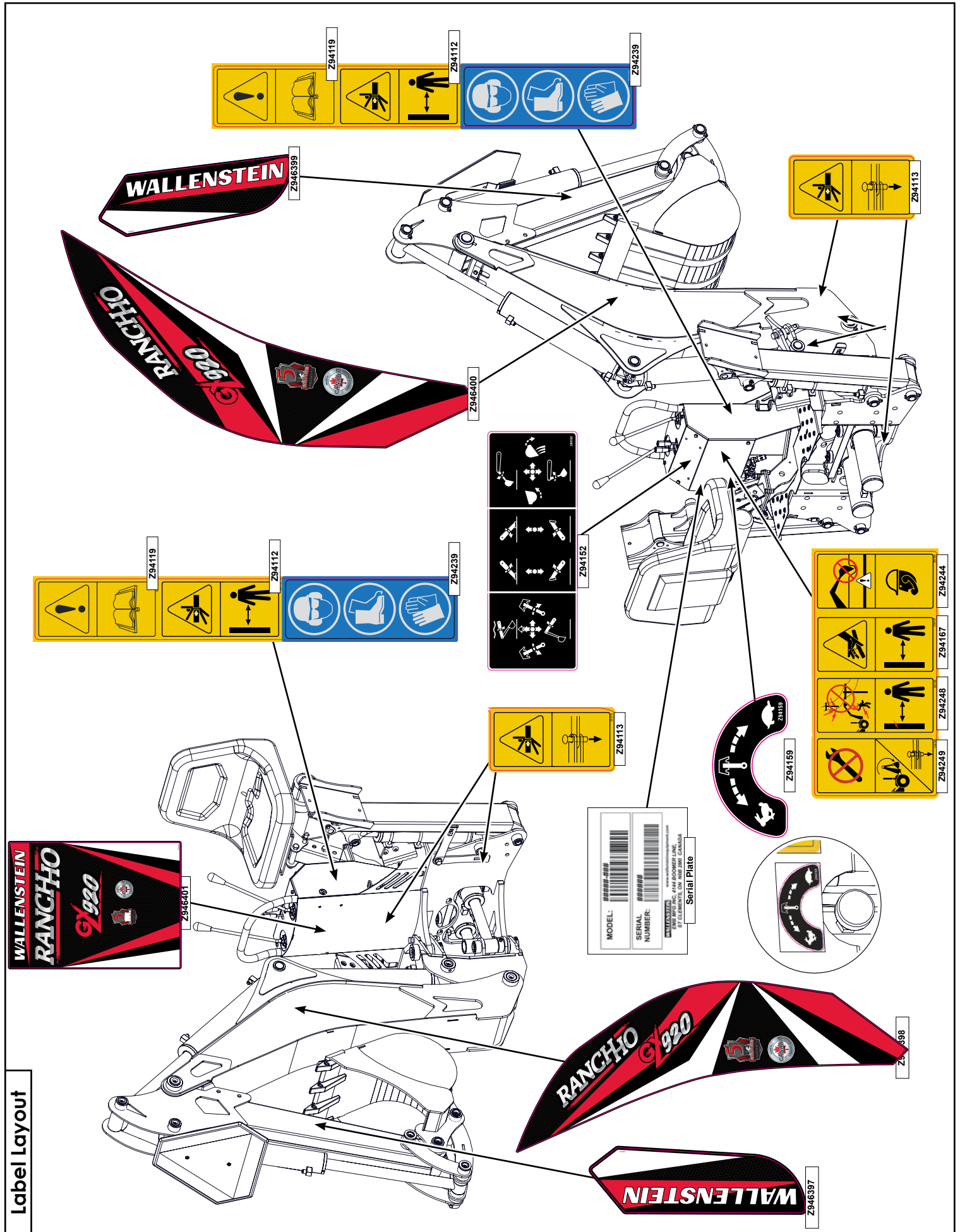

Accessories

PT300 3 Point Hitch

- Category I

PT322 3 Point Hitch

- Category II

BK2900 9" Bucket

- 3 teeth
- Bucket Volume: 0.8416 cubic ft

BK2120 12" Bucket

- 3 teeth
- Bucket Volume: 1.1694 cubic ft

BK2150 15" Bucket

- 4 teeth
- Bucket Volume: 1.4806 cubic ft

BK2180 18" Bucket

- 4 teeth
- Bucket Volume: 1.7912 cubic ft

BK2240 24" Bucket

- 5 teeth
- Bucket Volume: 2.413 cubic ft

BK2240D 24" Ditching Bucket

- No teeth
- Bucket Volume: 2.413 cubic ft

BT5290 Clamp on mechanical thumb

Using the mechanical thumb allows you to better control material that is difficult to scoop or place with precision

BT5300 Hydraulic thumb kit

- Factory installation only
- Using the hydraulic thumb allows you to better control material that is difficult to scoop or place with precision

PTO72 PTO Hydraulic Pump Kit 7GPM

The optional self contained PTO pump kit provides hydraulic power for tractors without available auxiliary power.

BT7220 Quick Change Bucket Adapter

Switches attachments quickly and easily with only one bolt and no hammering of pins.

BT7230 Ripper Tooth

Designed for initial breakup of dense, hard-packed material including frozen ground.

BT7240 Vertical Stabilizer Kit

Allows digging closer to objects such as buildings and foundations while maintaining stability.

BT7270 Closed Center Kit

Provides for backhoe conversion from open center to closed center operation for tractors equipped with closed centre hydraulics.

BP230 Street Pad Kit

Protects pavement or cement from cleats on the backhoe stabilizer legs



EMB Manufacturing Inc.
4144 Boomer Line - St. Clements, On - N0B 2M0 - Canada
Ph: (519) 699-9283 - Fax: (519) 699-4146
www.embmfg.com

**RANCHO SERIES BACKHOE
GE605, GX620, GX720,
GX920 & GX920XT
OPERATOR'S MANUAL**

Warning
Underground Utility Hazard
Contacting underground utilities can cause electrocution. You must contact an underground utility locating/marketing service before digging.

Caution
Stability Hazard
The tractor must have a front bucket loader installed before installing the subframe and backhoe. The front loader is required to offset the weight of the backhoe, as well as provide the stability required to operate the backhoe safely.

NOTICE
Operation Hazard
Wallenstein backhoes are designed to operate at a specific flow rate. Operating the backhoe above the specified flow rate will cause damage to the seals and will void the warranty.
GE605 3.5-6 gpm (13.3-22.8 lpm)
GX Series 5-7 gpm (18.9-26.5 lpm)

NOTICE
When mounting a GE605 or GX620 backhoe to a skid steer that has a flow rate greater than 8 GPM (32 lpm), BFC501 Flow Divider Kit is required to prevent damage to the seals and voiding the warranty. Do not run the skid steer in high flow mode.

**Keep this manual with the
Machine at all times** 

PRINTED IN CANADA
Rev: 160517

PART NUMBER: Z97103

**#Z97103
BACKHOE OPERATORS
MANUAL**

Available as a download at
www.wallensteinequipment.com