

# SETUP INSTRUCTIONS

---

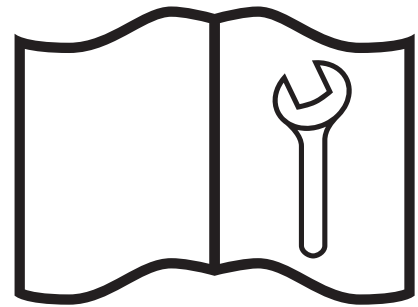

**WX410**  
**WX430**

## Safety

### WARNING!

Do not assemble the machine before you read the assembly instructions in this manual. Make sure that you understand the safety information and each step of the procedure before you assemble the machine.

Keep this manual with you and available for frequent reference as you assemble the machine.

### WARNING!

Use a hoist when to lift machine components that weigh 50 lb (23 kg) or more. Do not lift machine components that weigh more than you can lift without strain or injury.

### WARNING!

Use lift equipment with a lift capacity that is more than the weight of the machine component. Put jack stands or wood blocks under the machine to make it safe while you assemble the machine.

### WARNING!

Use the correct tools and equipment to assemble the machine. The use of incorrect tools can create safety hazards. A tool that breaks or slips during assembly risks personal injury. Repair or replace equipment or tools that are broken or defective.

### WARNING!

All lifting equipment (for example, straps, slings, chains, or ratchet blocks) must comply with the applicable local laws, standards, and regulations. Wallenstein Equipment does not accept responsibility for the use of unsafe equipment and work practices.

### WARNING!

Know the location of and keep away from overhead power lines and obstructions when you lift the machine. Contact with power lines can cause electrocution. Contact with overhead obstructions can damage the machine or components.

### WARNING!

Do not start or operate the machine before you read the Operator's Manual. Make sure that you fully understand all safety, operation, and maintenance information before you operate the machine.

Keep the Operator's Manual with the machine at all times and available for frequent reference.

### WARNING!

Make sure that all the fasteners are installed and torqued to the correct specifications. For more information, see *Specifications on page 15*.

### CAUTION!

Keep the assembly area clean and free of debris to prevent slips, trips, or falls.

**IMPORTANT!** Inspect the machine for damage from shipping. Contact the shipping company immediately if you find any damage to the machine.



Some components are attached to the skid with screws. Make sure that you only discard the shipping brackets.

Put the crate in a large, open area so that you can access the machine components from all sides during assembly.

Learn what the safety labels mean and know the safety hazards.

**WX410**

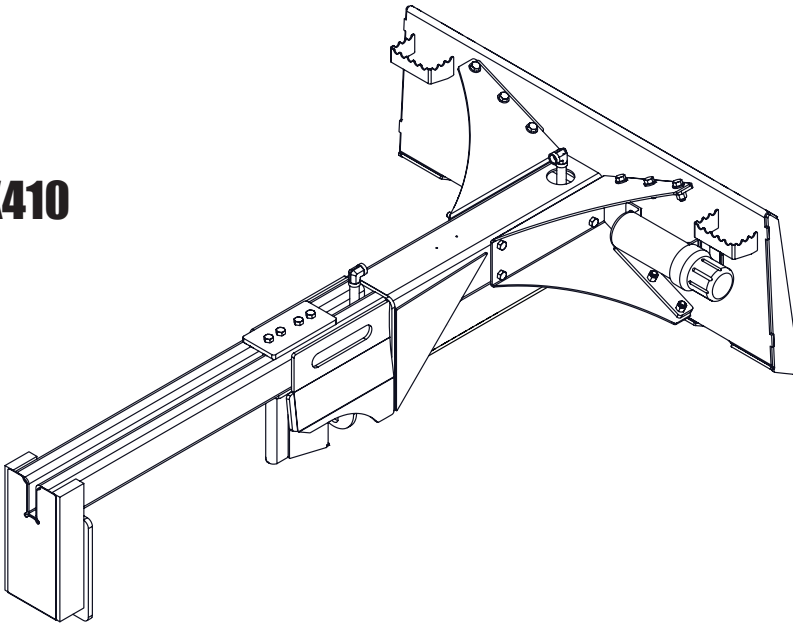

WX410

**WX430**

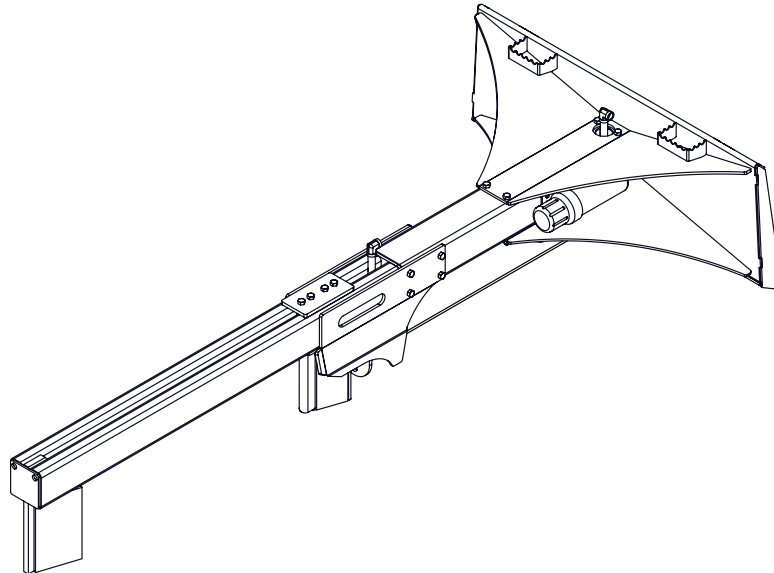

WX430

The assembly hardware is inside the Operator's Manual storage tube.

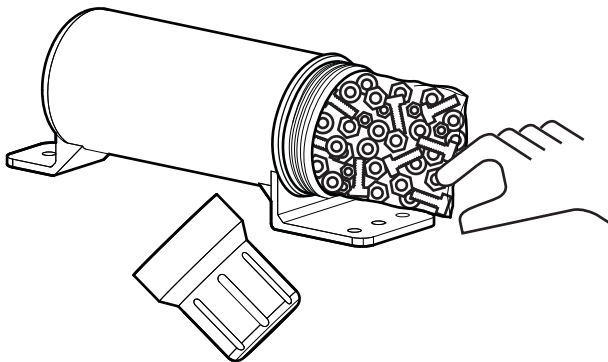

1

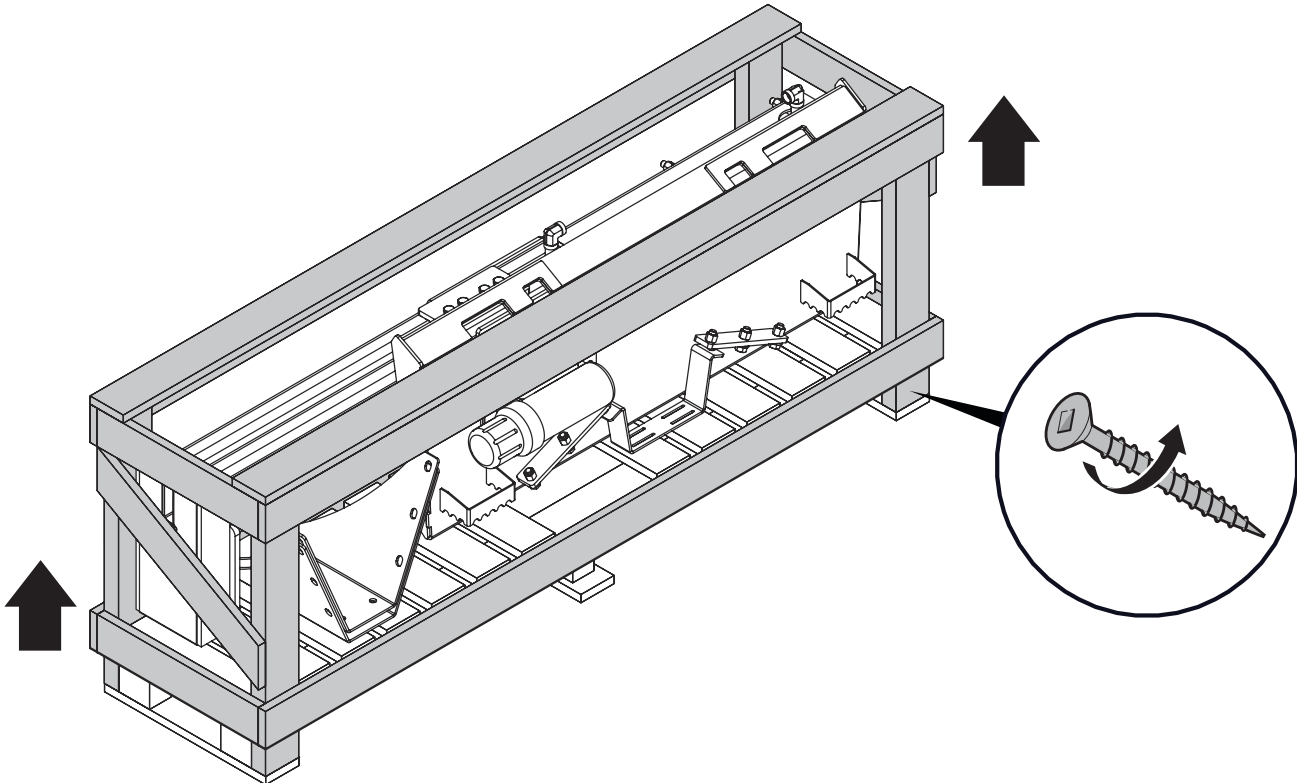

2

WX410

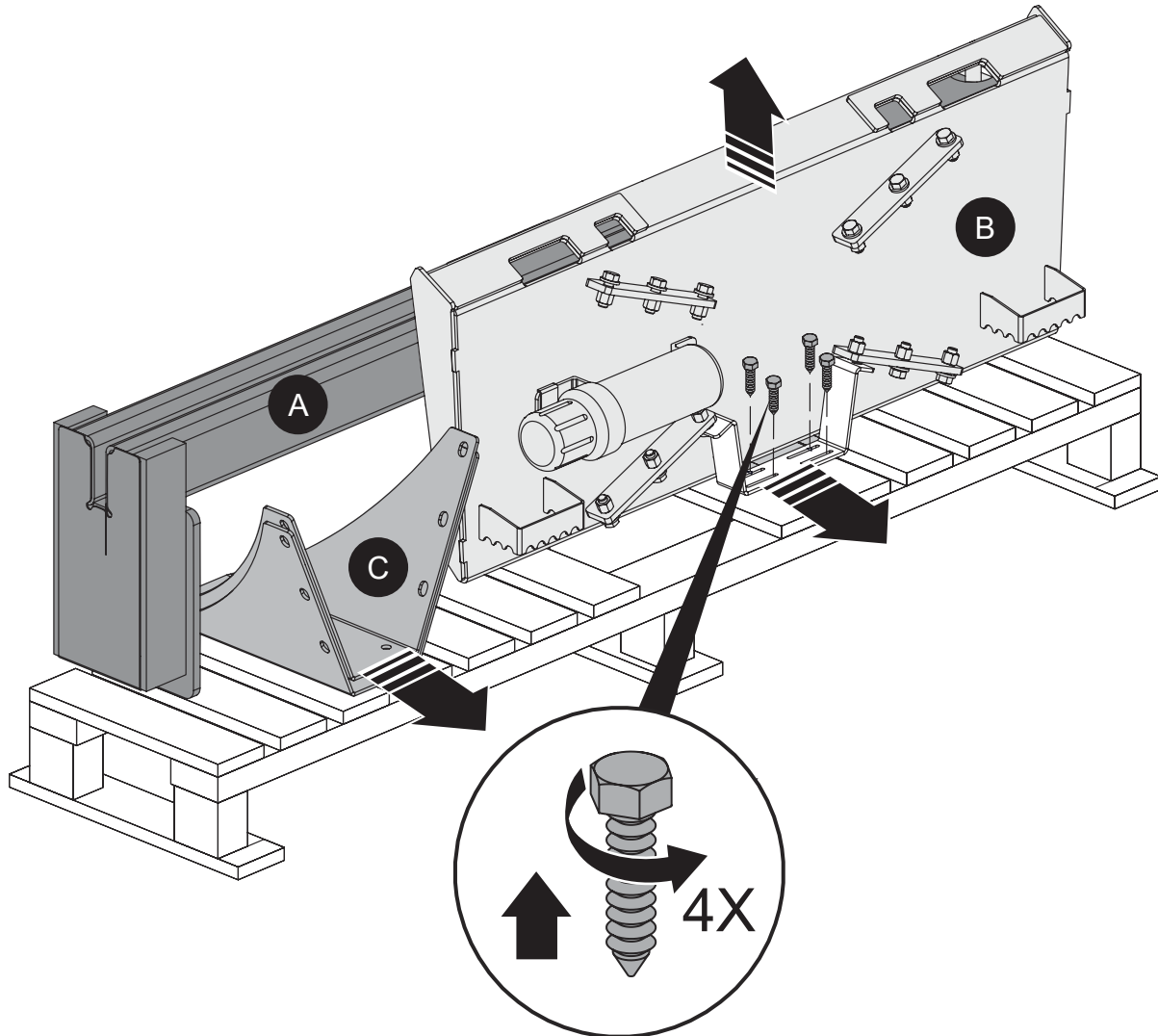

3

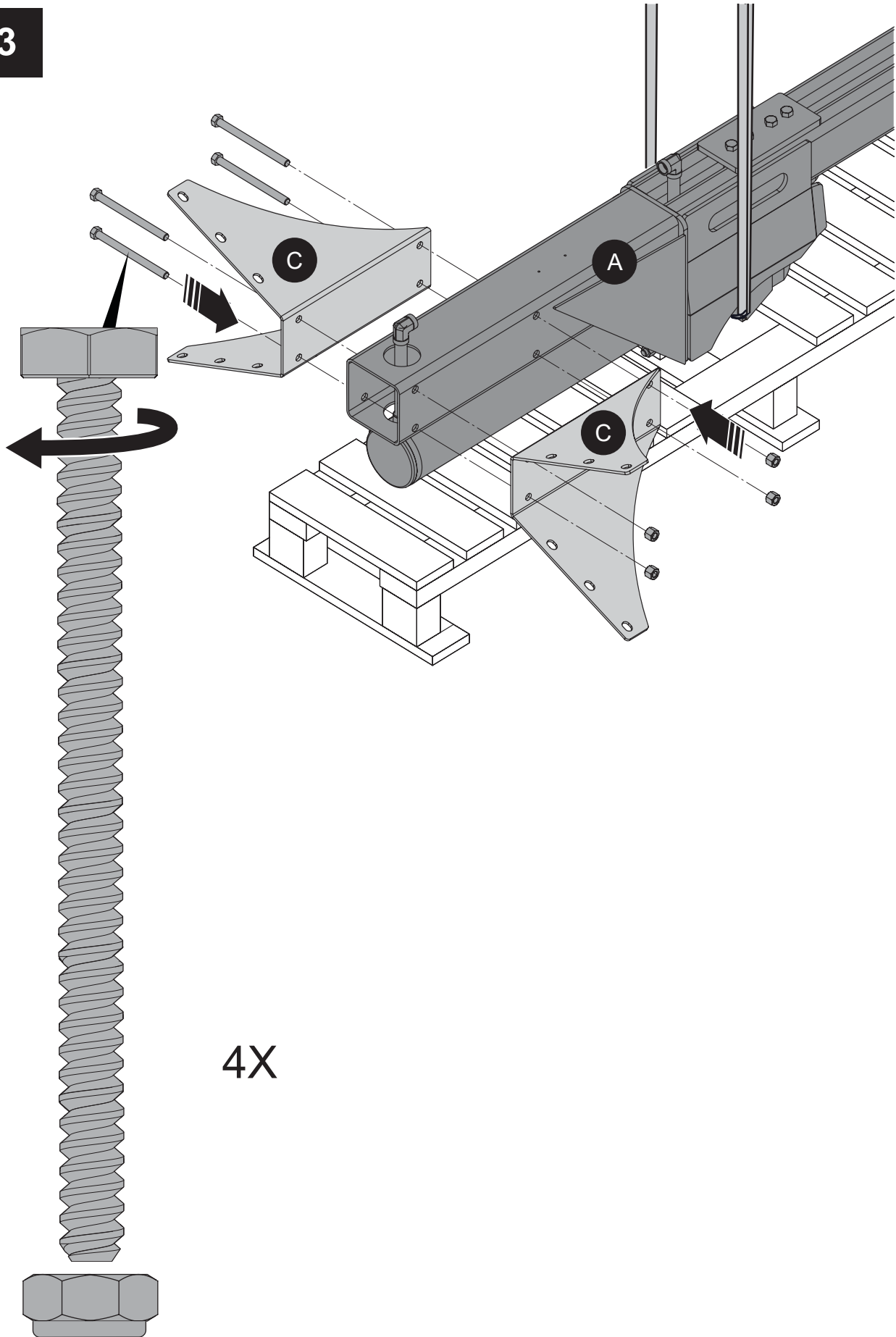

4

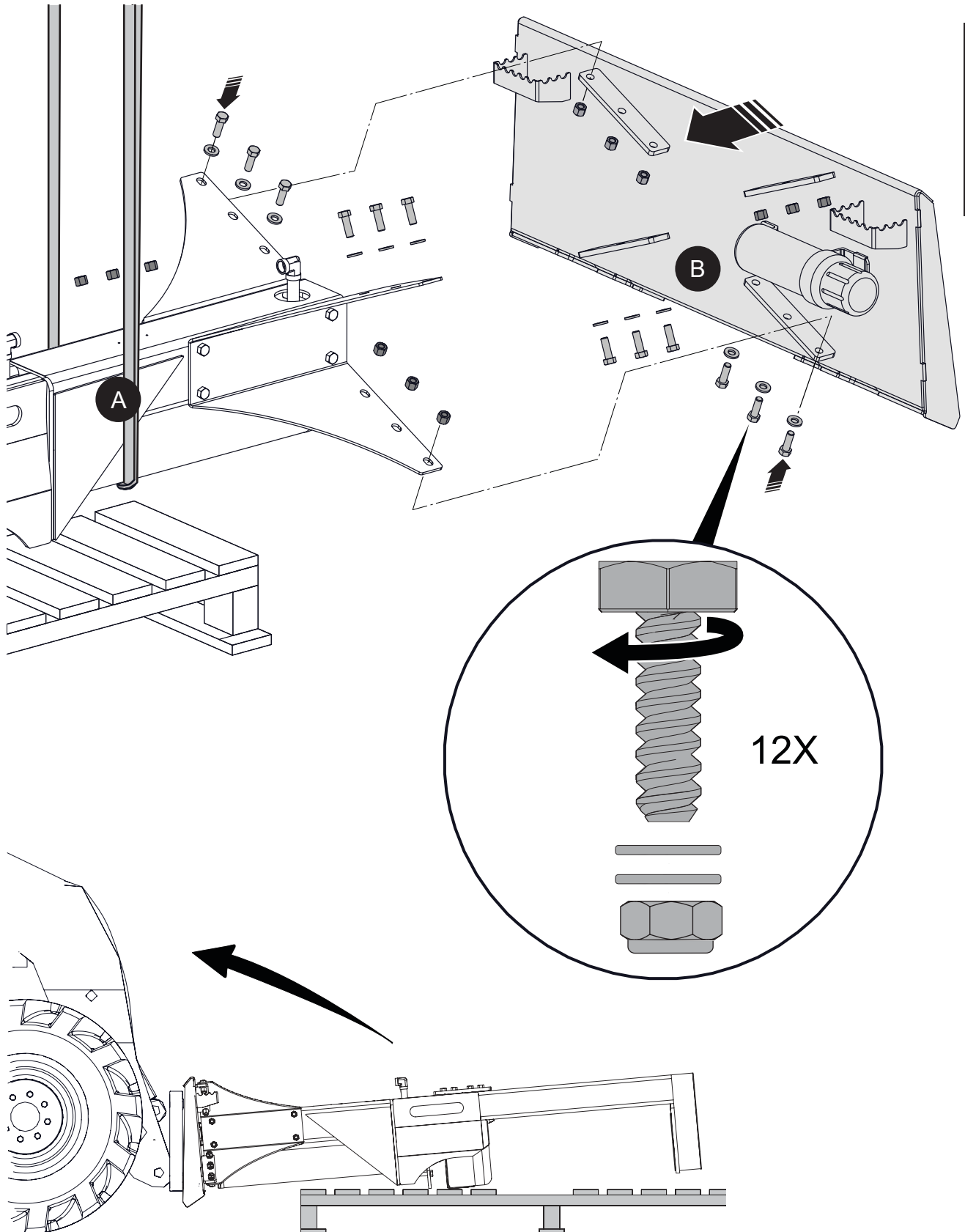

WX410

1

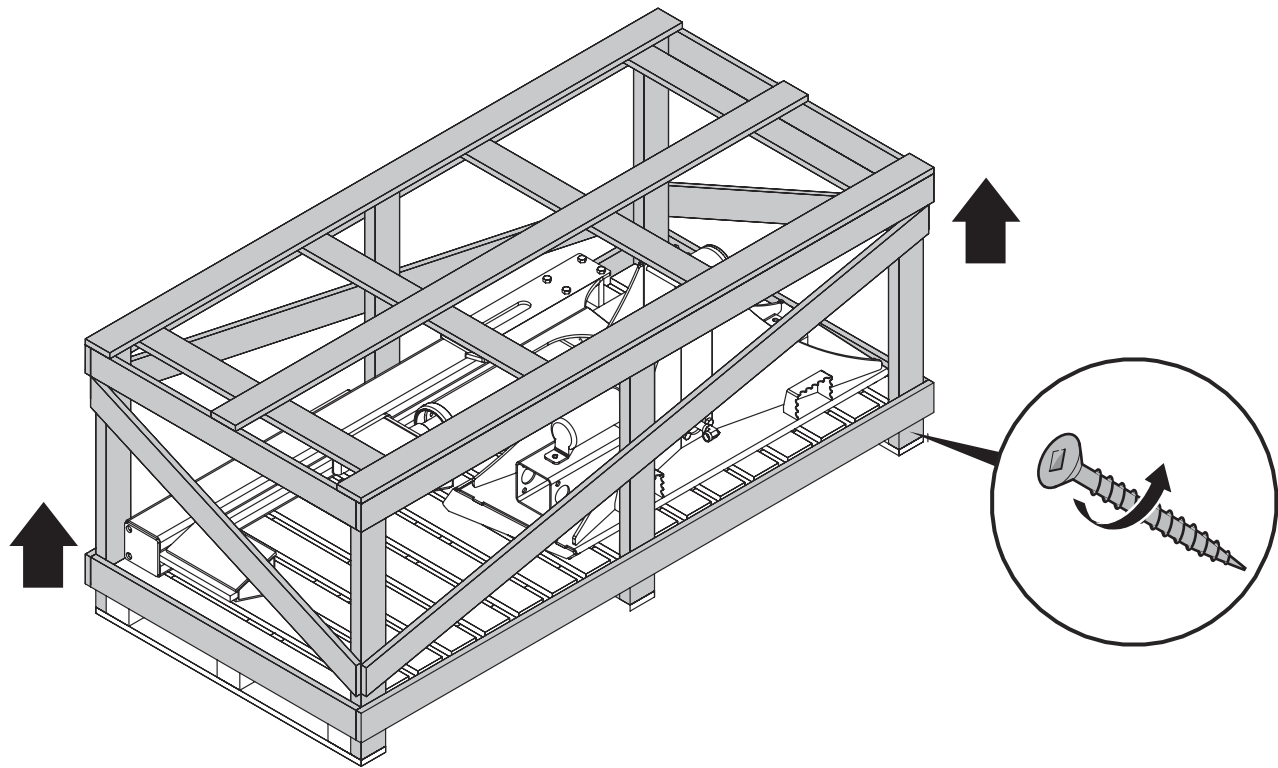



2

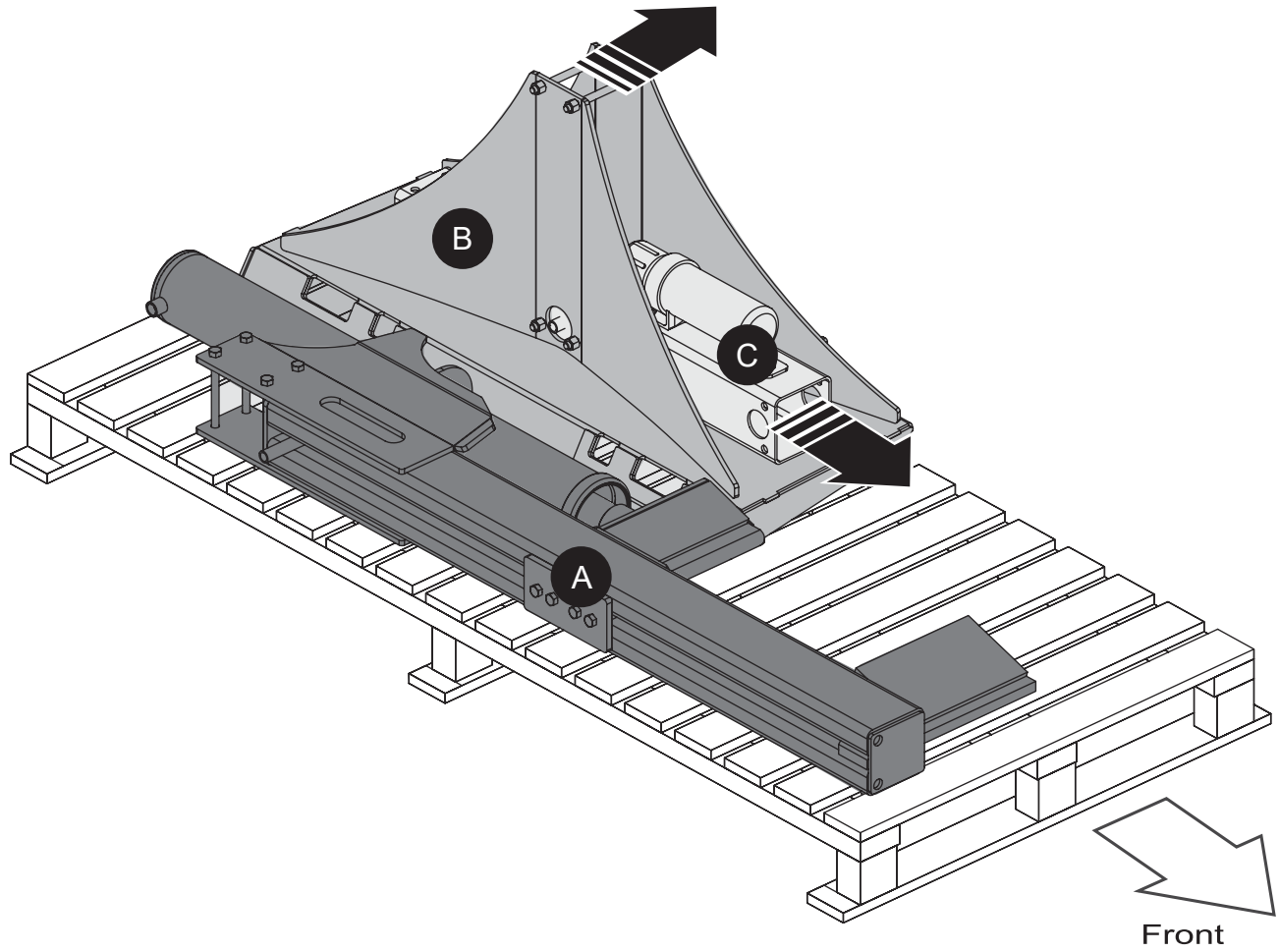

WX430

3

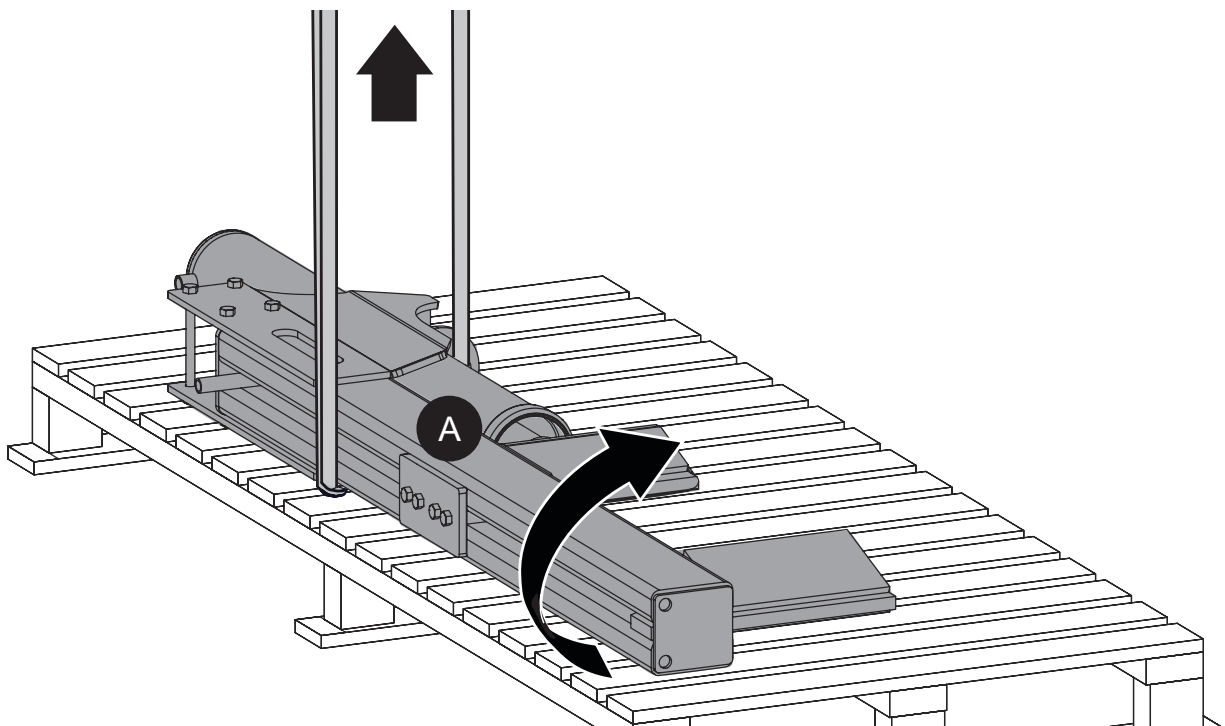

4

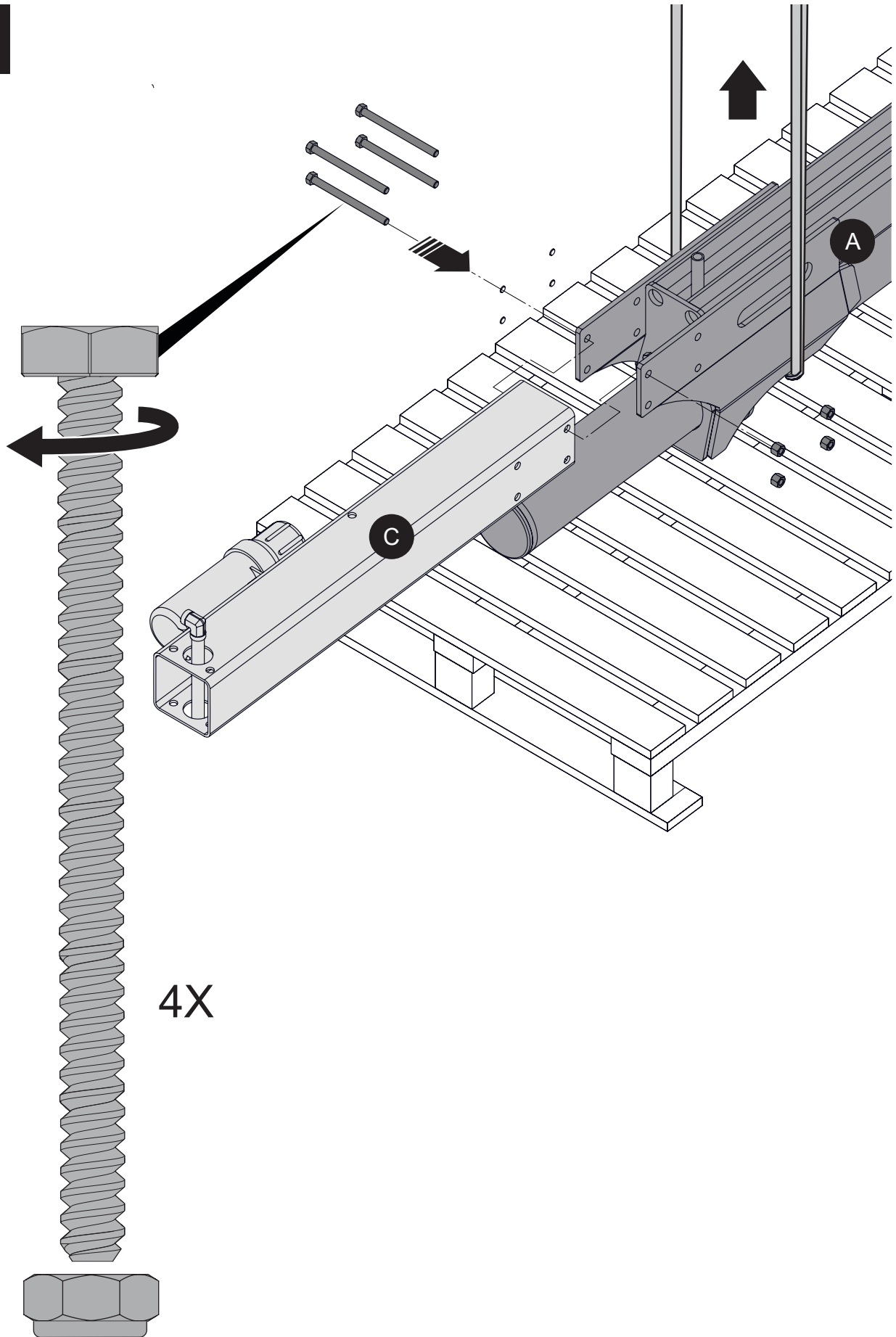

WX430

5

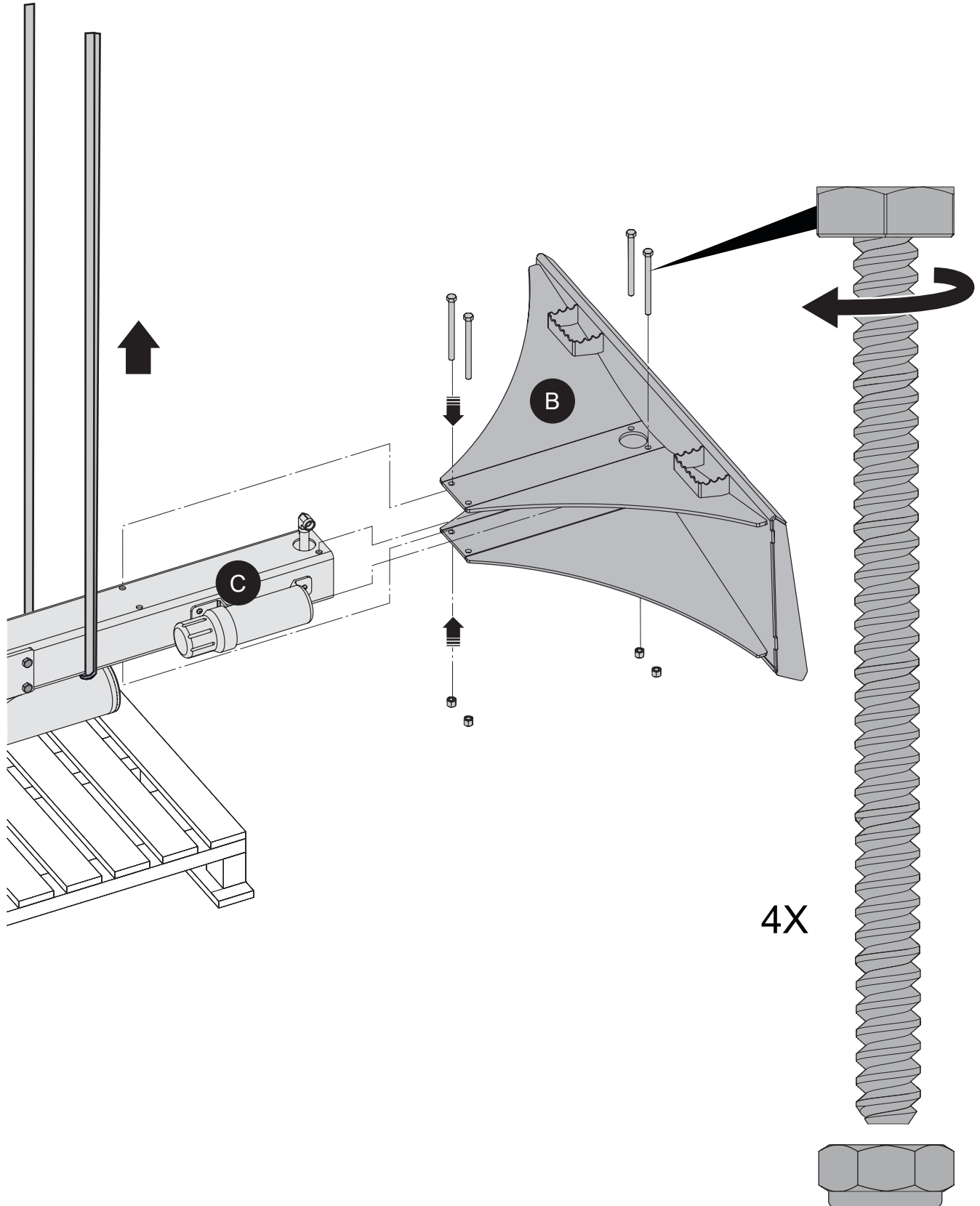

6

WX430

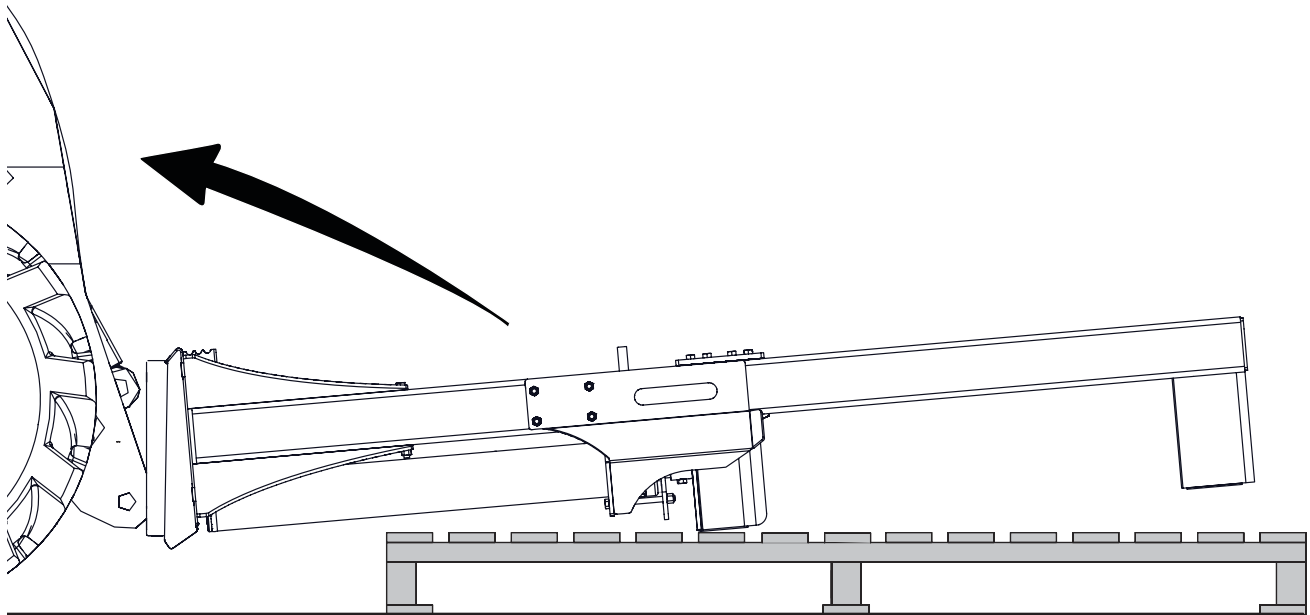

## 7

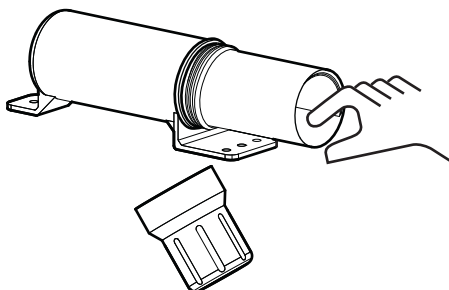

## Pre-delivery Inspection Checklist

Do the following pre-delivery inspections (PDI).

- \_\_\_\_\_ Hydraulic cylinder extends and retracts freely.
- \_\_\_\_\_ Hydraulic connections are tight, and hoses and fittings are in good condition.
- \_\_\_\_\_ There are no hydraulic fluid leaks.
- \_\_\_\_\_ All fasteners are torqued to the correct specifications.
- \_\_\_\_\_ All grease locations are lubricated.
- \_\_\_\_\_ Operator's Manual is in the document storage tube.

### Safety Checks

- \_\_\_\_\_ All safety labels are applied and legible.
- \_\_\_\_\_ All guards and shields are installed.
- \_\_\_\_\_ Operating and safety instructions were reviewed.

# Specifications

## Bolt Torque

**IMPORTANT!** If you replace hardware, use fasteners of the same grade.

**IMPORTANT!** The torque specifications in these tables are for non-greased or non-oiled threads. Do not grease or oil fastener threads unless otherwise indicated. When using a thread lock, increase the specified torque 5%.



Bolt grades are identified by the marks on top of the bolt head.

These bolt torque specification tables give the correct torque settings for common bolts and capscrews. Tighten all bolts to the torque that is specified in the table, unless otherwise indicated. Check the bolt tightness periodically.

Imperial Bolt Torque Specifications						
Bolt Diameter	Torque					
	SAE Gr. 2		SAE Gr. 5		SAE Gr. 8	
	lbf•ft	N•m	lbf•ft	N•m	lbf•ft	N•m
1/4 inch	6	8	9	12	12	17
5/16 inch	10	13	19	25	27	36
3/8 inch	20	27	33	45	45	63
7/16 inch	30	41	53	72	75	100
1/2 inch	45	61	80	110	115	155
9/16 inch	60	95	115	155	165	220
5/8 inch	95	128	160	215	220	305
3/4 inch	165	225	290	390	400	540
7/8 inch	170	230	420	570	650	880



SAE Gr. 2



SAE Gr. 5



SAE Gr. 8

Metric Bolt Torque Specifications				
Bolt Diameter	Torque			
	Gr. 8.8		Gr. 10.9	
	lbf•ft	N•m	lbf•ft	N•m
M3	0.4	0.5	1.3	1.8
M4	2.2	3	3.3	4.5
M6	7	10	11	15
M8	18	25	26	35
M10	37	50	52	70
M12	66	90	92	125
M14	83	112	116	158
M16	166	225	229	310
M20	321	435	450	610
M30	1,103	1,495	1,550	2,100



8.8



10.9

## Hydraulic Fitting Torque

Tighten flare-type tube fittings:

1. Check the flare and flare seat for defects that might cause leaks.
2. Align the tube with the fitting before tightening.
3. Hand-tighten the swivel nut until it is snug.
4. To prevent the tube from twisting, use two wrenches. Place one wrench on the connector body and tighten the swivel nut with the second wrench. Torque the fitting to the correct specification.

If a torque wrench is not available, use the flats from finger tight (FFFT) method.

Hydraulic Fitting Torque Specifications					
Tube size OD	Hex size across flats	Torque		Flats from finger tight	
		lbf•ft	N•m	Flats	Turns
Inches	Inches				
3/16	7/16	6	8	2	1/6
1/4	9/16	11–12	15–17	2	1/6
5/16	5/8	14–16	19–22	2	1/6
3/8	11/16	20–22	27–30	1-1/4	1/6
1/2	7/8	44–48	59–65	1	1/6
5/8	1	50–58	68–79	1	1/6
3/4	1-1/4	79–88	107–119	1	1/8
1	1-5/8	117–125	158–170	1	1/8

Specifications are for non-lubricated connections.











**MAKING WORK FEEL MORE LIKE PLAY™**

[WallensteinEquipment.com](http://WallensteinEquipment.com)

