



WX910 Trailer Log Splitter Parts Manual

S/N 320001 & After



Foreword

EMB Mfg. has prepared this parts manual to assist customers in ordering quality OEM replacement parts.

Proper and regular service and replacing old, worn or broken parts with the correct Wallenstein parts are essential to prolonging the life of your Wallenstein product. Please refer to this manual before ordering any replacement parts.

All information contained in this parts manual is based on the latest product specification available at the time of printing this manual. If your product differs from the specifications contained within this manual contact EMB Mfg. for information.

EMB reserves the right to alter specifications on their products at any time.

Reproduction of this parts manual of any kind is prohibited without prior written permission from EMB Mfg.

Note: Log splitters with factory installed light kits will have a VIN number included. The last six numbers of this VIN number are the splitters serial number

Example: 2E9US1112BSXXXXXX

Serial Number

Table of Contents

Main Parts	4
Cylinder	5
Valve & Fittings	6
Valve	7
Hub	9
Engine & Pump	10
Light Kit (Optional)	11
Decal Breakdown	12

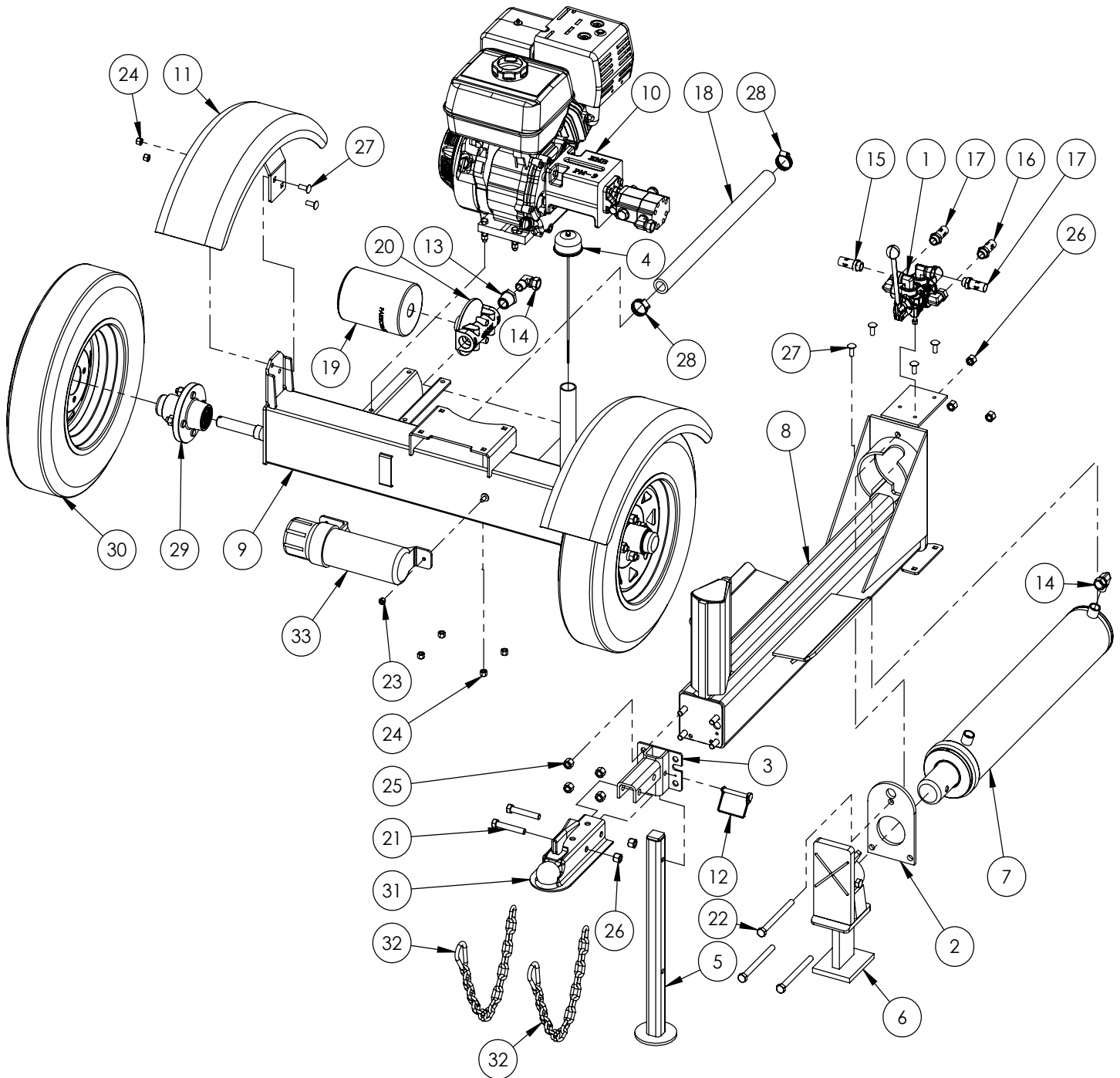

WX910 PARTS BREAKDOWN

ITEM	PART NO.	DESCRIPTION	QTY
1	2011A103	Assembly, Valve with Fittings	1
2	2032S213	Plate, Cylinder Retaining	1
3	2052W704	Weldment, Hitch Mount	1
4	2054A402	Breather cap dipstick	1
5	2054W406	Jack Stand, Front	1
6	2055A501	Ass'y, Sliding Hvy Pushblock	1
7	2055C501	Cylinder, 4-1/2 x 24 x 2-1/2	1
8	2055W501	Cylinder Weldment, WX910	1
9	2055W502	Weldment, Main Trailer	1
10	2061A103	Assy, 9hp Engine to 16gpm Pump	1
11	2061W103	Weldment, Fender	2
12	Z12432	Snapper Pin 3/8 x 2-1/2	1
13	Z51223	Reducer, MP x FP 1608	1
14	Z51331	Elbow 90 MP x FPX 0808	2
15	Z52301	1/2 Hose MP08 x MP08 x 16"	1
16	Z52303	1/2 Hose, 1/2MP x 1/2MP x 36"	1
17	Z52305	1/2 Hose, MP08 x MP08 x 24"	2
18	Z52405	Suction Hose, 1" x 22"	1

ITEM	PART NO.	DESCRIPTION	QTY
19	Z55303	Oil Filter - 1" - Particulate	1
20	Z55304	Filter Cap, FP16 x FP16	1
21	Z71530	Hex Bolt 1/2NC x 3	2
22	Z71560	Hex Bolt 1/2NC x 6	3
23	Z72221	Hex Lock Nut 5/16NC	1
24	Z72231	Hex Lock Nut 3/8NC	8
25	Z72251	Hex Lock Nut 1/2NC	4
26	Z72251	Hex Lock Nut 1/2NC	5
27	Z76231	Carriage Bolt 3/8NC x 1	8
28	Z79401	Hose Clamp, #16	2
29	Z91202	Assembly, 1000# 4-Bolt Hub	2
30	Z91302	5.30-12 LRB SportTrail 4 Spoked	2
31	Z91614	2" Hitch Coupler	1
32	Z92303	Safety Chain 1/4 x 2'	2
33	Z96503	Manual Tube 3-1/2 Short	1

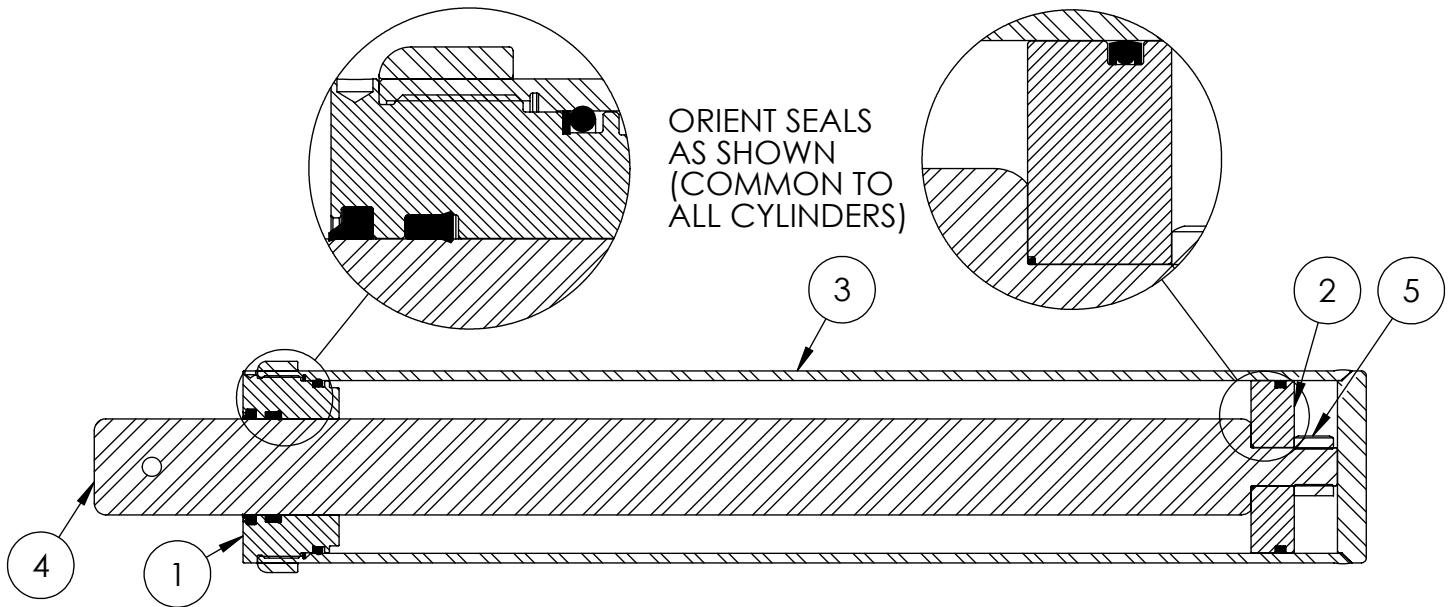

4-1/2" WOODSPLITTER CYLINDER PARTS BREAKDOWN

ITEM	PART NO.	DESCRIPTION	QTY
1	G450-250SA	4-1/2" Bore x 2-1/2" Rod Gland With Seals	1
2	P100-450SA	4-1/2" Bore Piston With Seals	1
3	2055C5014	Barrel, 4-1/2"	1
4	2055C5012	Rod, 2-1/2x 1	1
5	Z72292G8	Hex Lock Nut 1NF Grade 8	1
6	SLK-4525	Seal Kit, 4-1/2 x 2-1/2	1

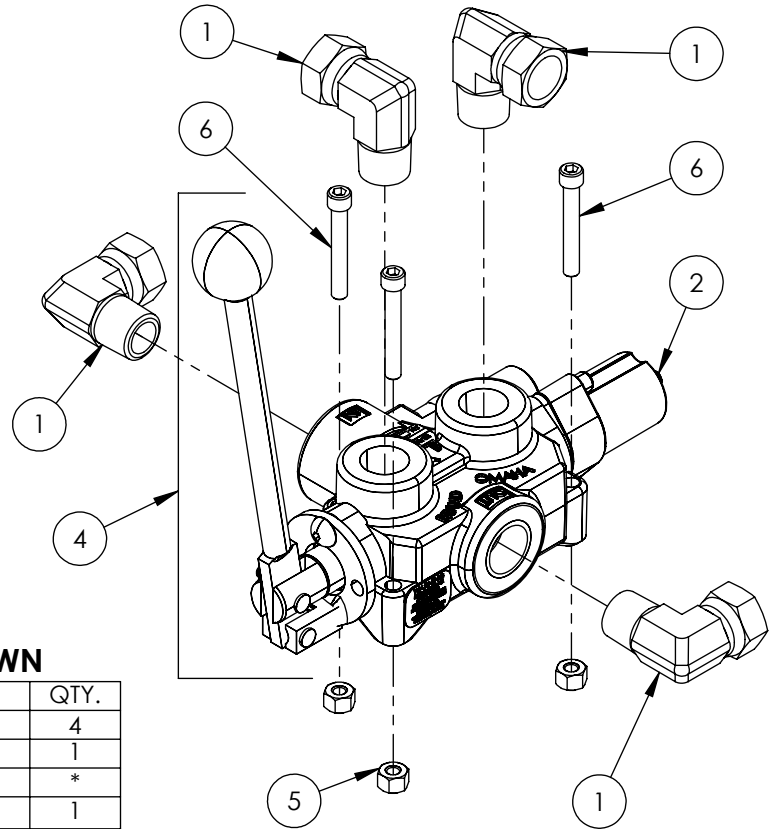

VALVE AND FITTINGS PARTS BREAKDOWN

ITEM	PART NO.	Description	QTY.
1	Z51331	Elbow 90 MP x FPX 0808	4
2	Z56209	Valve, Single Function Detent	1
3	*Z56210*	Valve, Closed Center	*
4	Z56915	Complete Handle Kit for Z56209	1
5	Z72111	Hex Lock Nut 1/4NC	3
6	Z75114	SHCS, 1/4NC x 1-3/4	3

CLOSED CENTER VALVE REQUIRED FOR "C" MODELS.

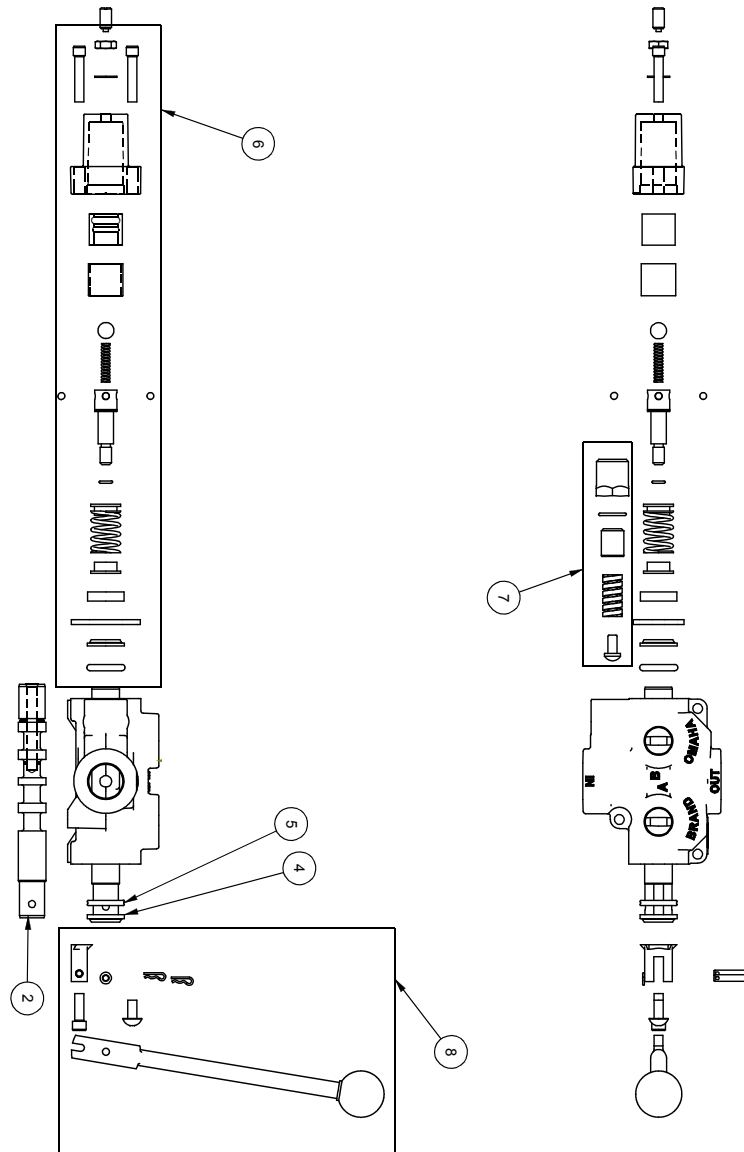

ITEM NO.	QTY.	PART NO.	DESCRIPTION
1	1	AOCAS1B	AO CASTING
2	1	LS304T4J	SPOOL
3	1	P1740	NAME TAG
4	1	SF305	WIPER
5	1	SF304	QUAD RING
6	1	SUB-LS	SUB-LS
		B9057	7/16 BALL
		DC7604	3/16 BALL
1	1	SF306	RETAINER
1	1	SF477L	SH LS ENDCAP
1	1	XDC672	LS SLEEVE
1	1	SF483	SPACER
2	2	SF486	ALLEN SCREW
1	1	SF489	CENTER STOP
1	1	SF490	CENTERING SPRING
1	1	SF492	HOUSING
1	1	SF315	SPACER
1	1	LS305	DETENT SPRING
1	1	DC7583	O-RING-3-902
1	1	SF496	O-RING, BLUE, METRIC
1	1	LS306	LS WIPER
1	1	SF502	5/16 LOCK WASHER
1	1	SF503	PLUNGER, SPRING
1	1	SF504	5/16 HEX JAM NUT
7	1	SUB-R	RELIEF
1	1	P1603	CAP NUT
1	1	SF322	O-RING-2-016
1	1	SF364A	ADJ. SCREW
1	1	B605	SPRING
1	1	SF361A	POPPET
1	1	Z56915	HANDLE KIT
8	1	SF377	RETAINER
1	1	SF376	SEAL RETAINER
1	1	SF367A	CLEVIS
1	1	SF368	HANDLE
2	2	SF369	PIN
1	1	P1767	PIN CLIP
1	1	HR5	MACH. SCREW
1	1	SF311	KNOB
1	1	SF308	CAP SCREW
1	1	SF303T4J	SPOOL
9	1	P1654	WARNING TAG

ITEM NO.	QTY.	PART NO.	DESCRIPTION
1	1	B5057	7/16 BALL
2	4	DC7604	3/16 BALL
3	1	SF306	RETAINER
4	1	SF477L	SH LS ENDCAP
5	1	SF480	SD SLEEVE
6	1	SF483	SPACER
7	2	SF486	ALLEN SCREW
8	2	SF489	CENTER STOP
9	1	SF490	CENTERING SPRING
10	1	SF492	HOUSING
11	1	SF315	SPACER
12	1	LS305	DETENT SPRING
13	1	DC7583	O-RING 3-902
14	1	SF496	METRIC O-RING
15	1	LS306	LS WIPER
16	1	SF502	5/16 LOCK WASHER
17	1	SF503	SPRING PLUNGER
18	1	SF504	5/16 HEX JAM NUT

Note: This diagram is for reference only. Parts not sold separately.

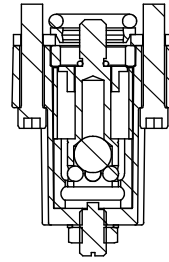
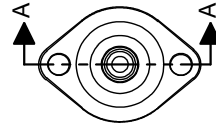
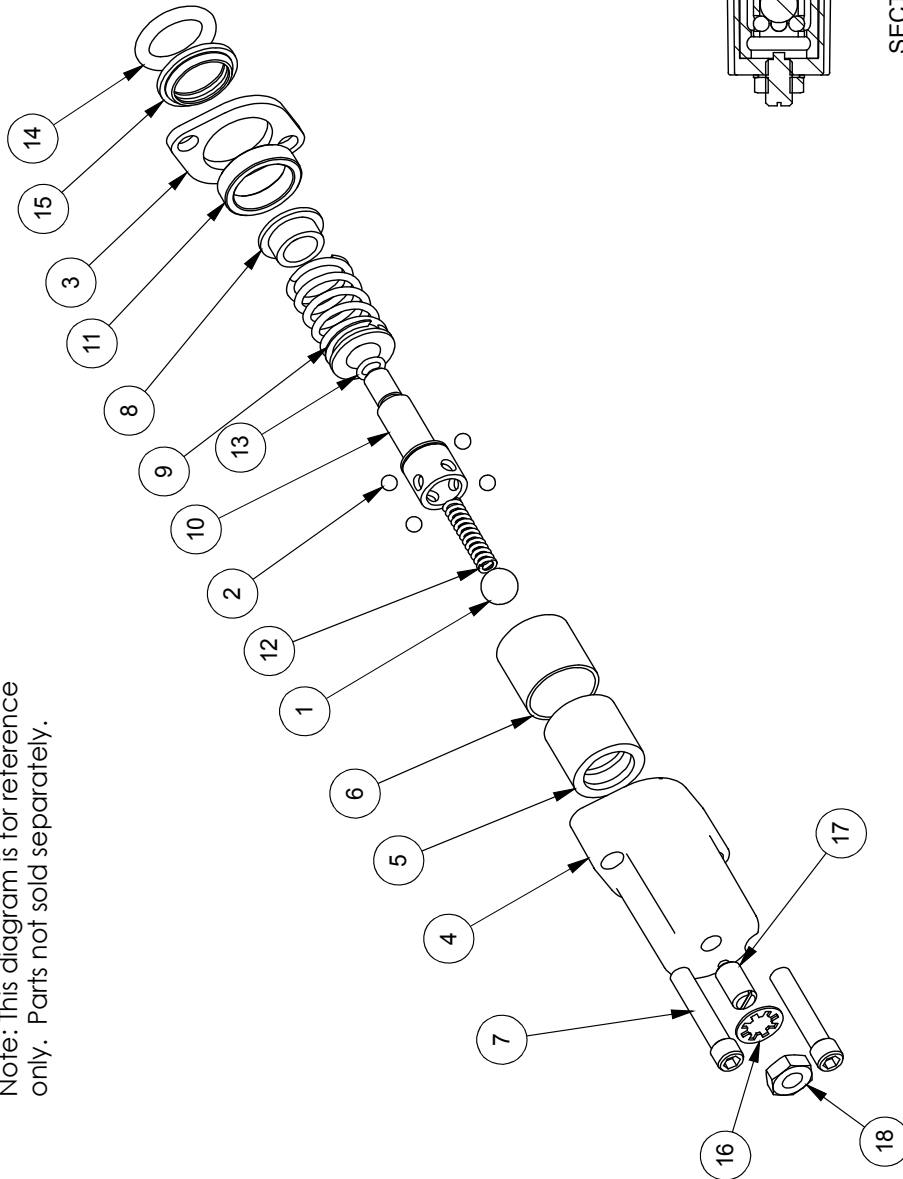

SECTION A-A

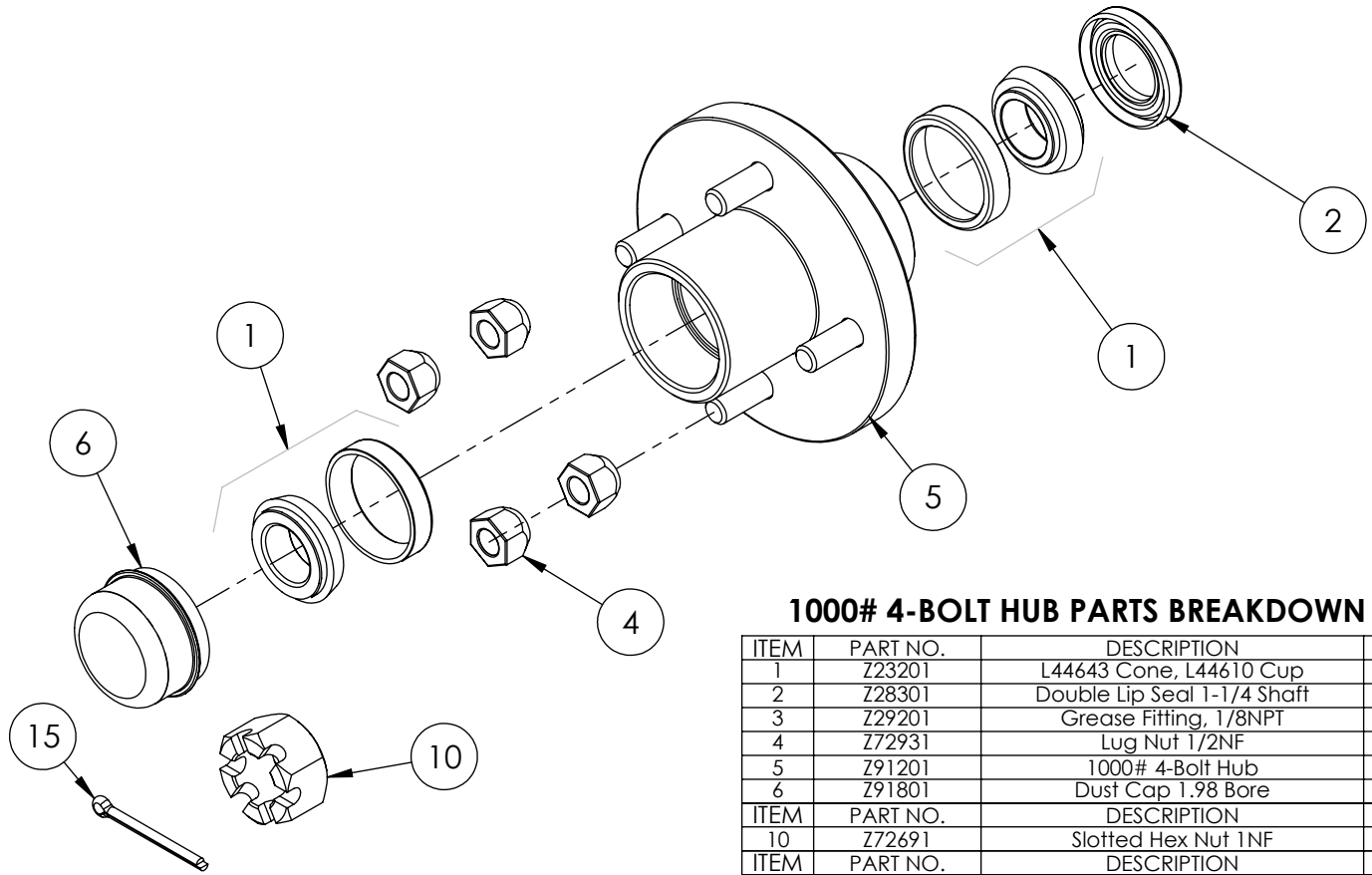

1000# 4-BOLT HUB PARTS BREAKDOWN

ITEM	PART NO.	DESCRIPTION	QTY
1	Z23201	L44643 Cone, L44610 Cup	2
2	Z28301	Double Lip Seal 1-1/4 Shaft	1
3	Z29201	Grease Fitting, 1/8NPT	1
4	Z72931	Lug Nut 1/2NF	4
5	Z91201	1000# 4-Bolt Hub	1
6	Z91801	Dust Cap 1.98 Bore	1
ITEM	PART NO.	DESCRIPTION	QTY
10	Z72691	Slotted Hex Nut 1NF	1
ITEM	PART NO.	DESCRIPTION	QTY
15	Z12322	Cotter Pin 3/16 X 2	1

2061A103 9hp ENGINE / PUMP ASSEMBLY PARTS

ITEM	PART NO.	DESCRIPTION	QTY
1	Z47136	Honda 9hp Engine	1
2	Z53802	Pump Mounting, PM-9	1
3	Z46404	Shaft Coupler L095 x 1	1
4	Z46405	Coupler Spider L095	1
5	Z46409	Shaft Coupler L095 x 1/2	1
6	Z53205	Pump, 16gpm Two-Stage	1
7	Z51331	Elbow 90 MP x FPX 0808	1
8	Z71210	Hex Bolt 5/16NC x 1	4
9	Z46533	Key 1/4 x 1/4 x 1	1
10	Z46592	Woodruff Key, 1/8 x 1/2	1
11	Z71274	Hex Bolt, 5/16NF x 1	4
12	Z71320	Hex Bolt 3/8NC x 2	4
13	Z72231	Hex Lock Nut 3/8NC	4

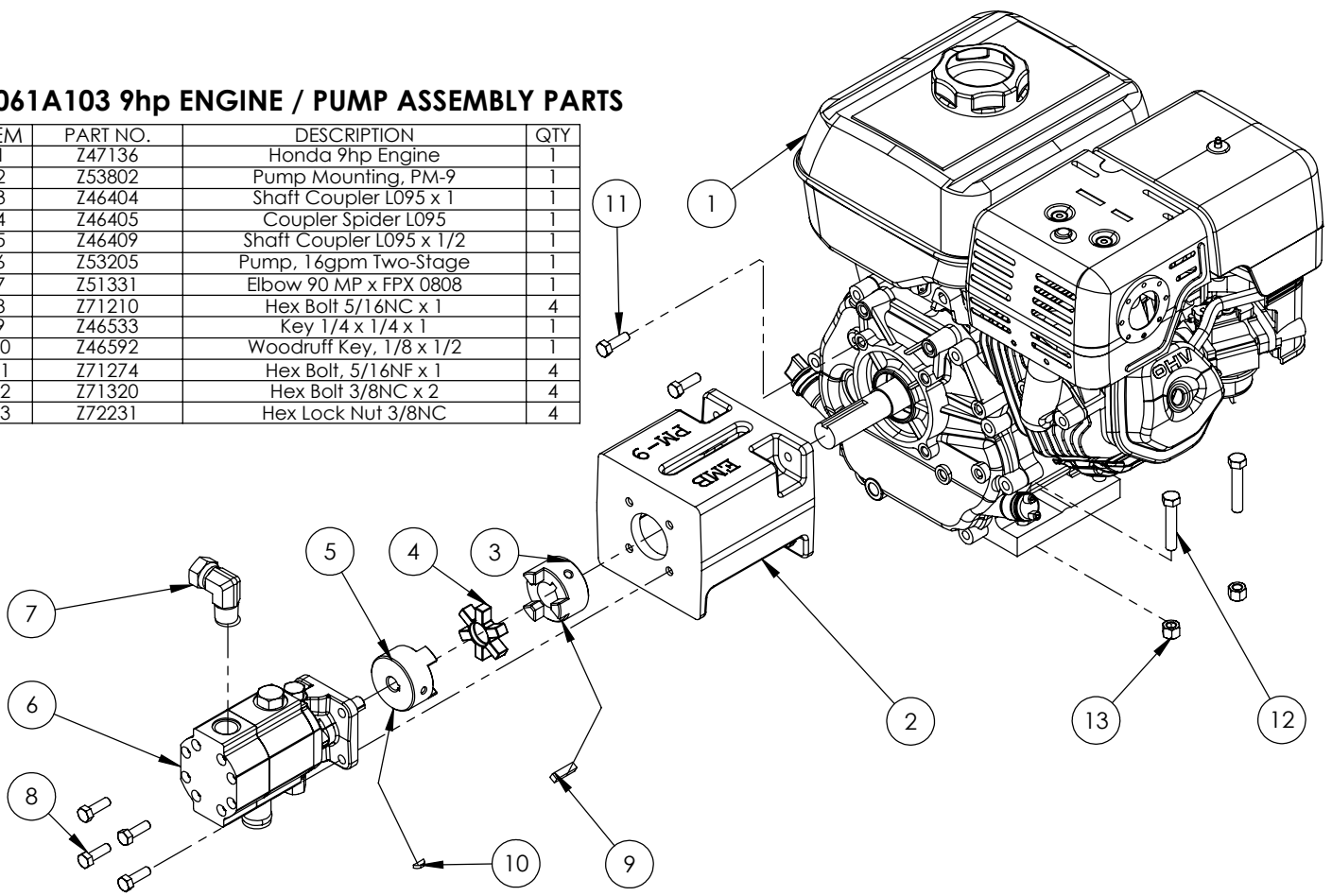

WX TRAILER SPLITTER WIRING

RIGHT SIDE

KEY
 Bl - BLUE
 Br - BROWN
 Gr - GREEN
 Rd - RED
 Yl - YELLOW
 Bk - BLACK
 Wh - WHITE

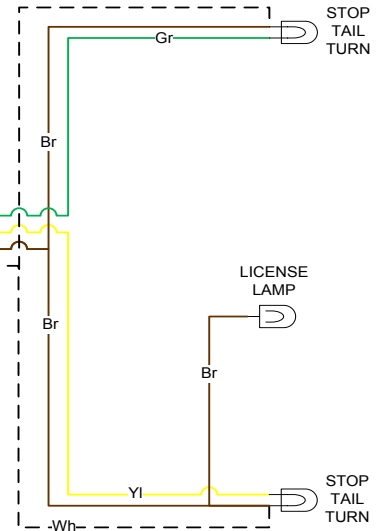
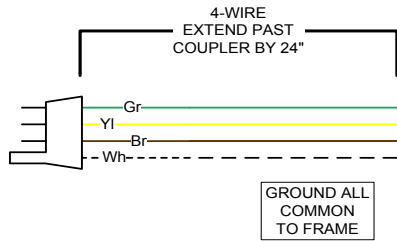

LEFT SIDE

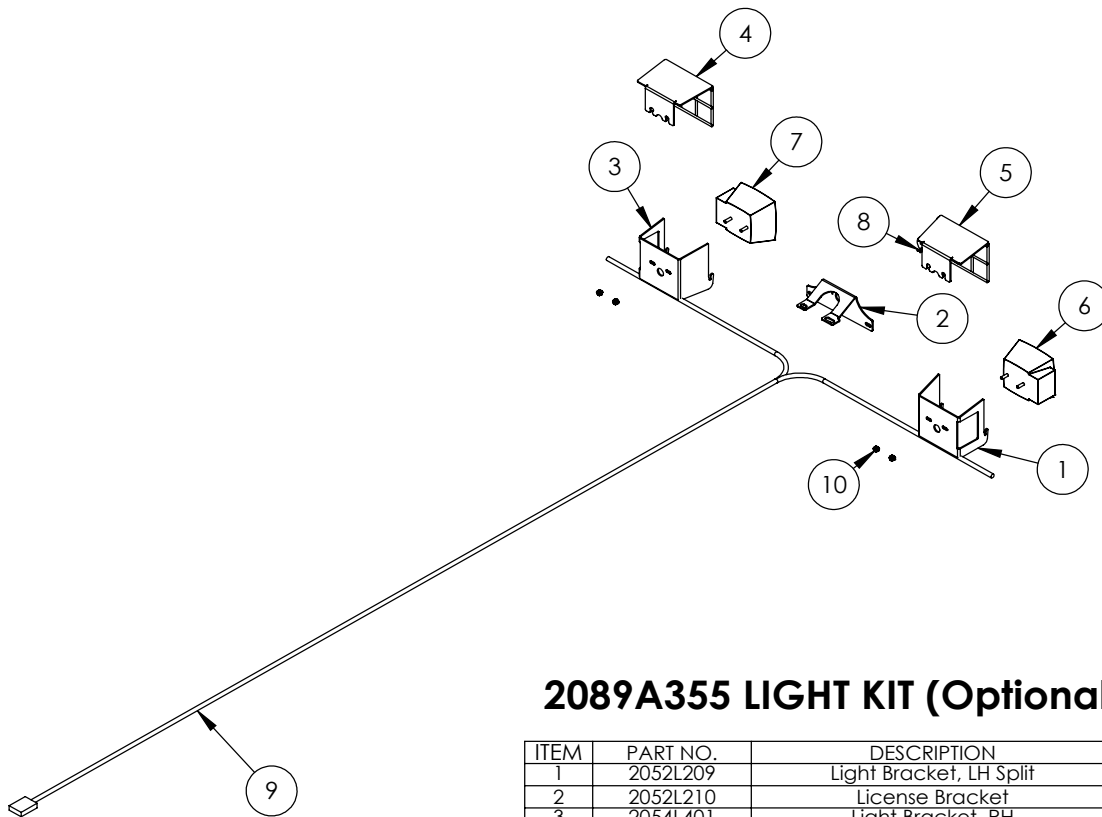

2089A355 LIGHT KIT (Optional)

ITEM	PART NO.	DESCRIPTION	QTY
1	2052L209	Light Bracket, LH Split	1
2	2052L210	License Bracket	1
3	2054L401	Light Bracket, RH	1
4	2054W403	Light Guard, RH	1
5	2054W404	Light Guard, LH	1
6	Z61106	Stop, Turn, Tail Light LH	1
7	Z61107	Stop, Turn, Tail Light RH	1
8	Z61301	License Lamp	1
9	Z62105	110' Wishbone Trailer Harness	1
10	Z72941	Serrated Washer Nut 1/4NC	4

HORIZONTAL LOG SPLITTER DECAL BREAKDOWN

ITEM	PART NO.	DESCRIPTION	QTY
1	Z94039	CAUTION - Read Manual	1
2	Z94040	WARNING - Moving Wedge	2
3	Z94067	Clear Guide	2
4	Z94056	Wallenstein	2
5	Z94019	Made in Canada	3
6	Z94066	Apply Oil or Grease	1

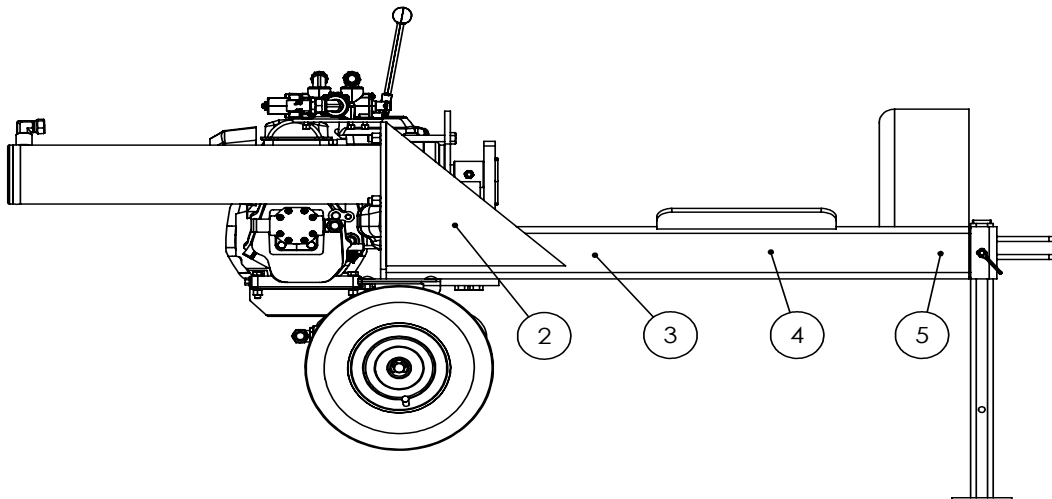
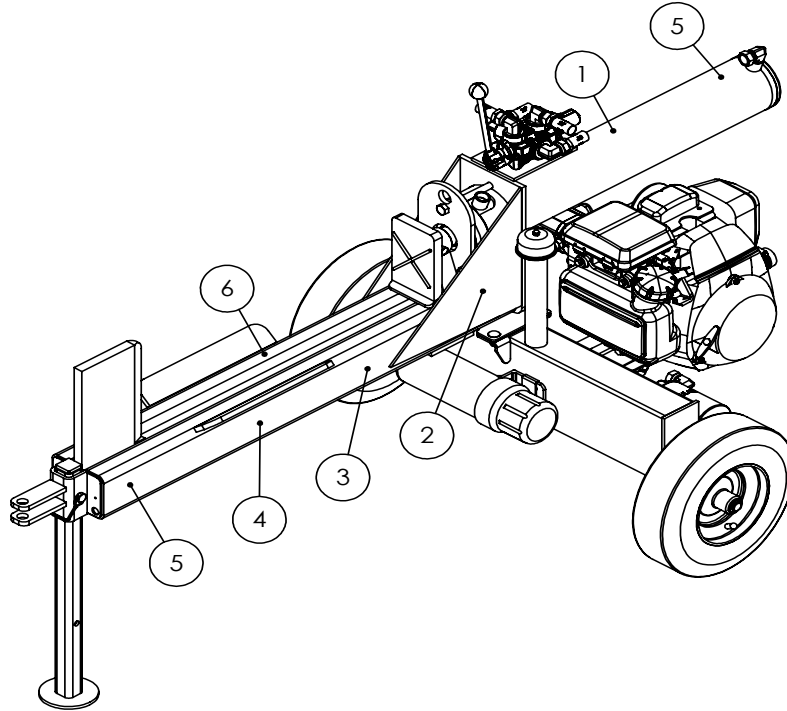

Trailer Splitter Decals

Z94056



Z94067



Z94019



Z94066



Z94039

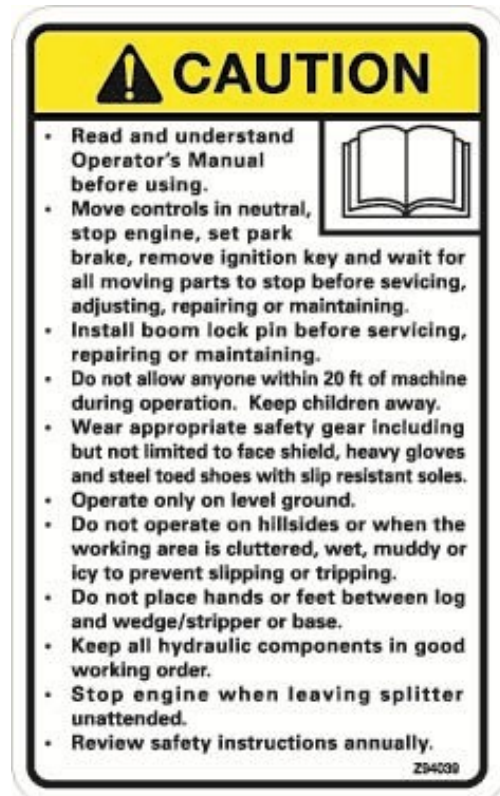

Z94040



TWO PANEL HORIZONTAL LOG SPLITTER DECAL BREAKDOWN

ITEM	PART NO.	DESCRIPTION	QTY
1	Z94119	CAUTION - Read Manual	1
2	Z94123	Keep Feet Clear	1
3	Z94067	Clear Guide	2
4	Z94056	Wallenstein	2
5	Z94019	Made in Canada	3
6	Z94142	99 dB Sound Level	1
7	Z94124	Keep Hands Clear	1

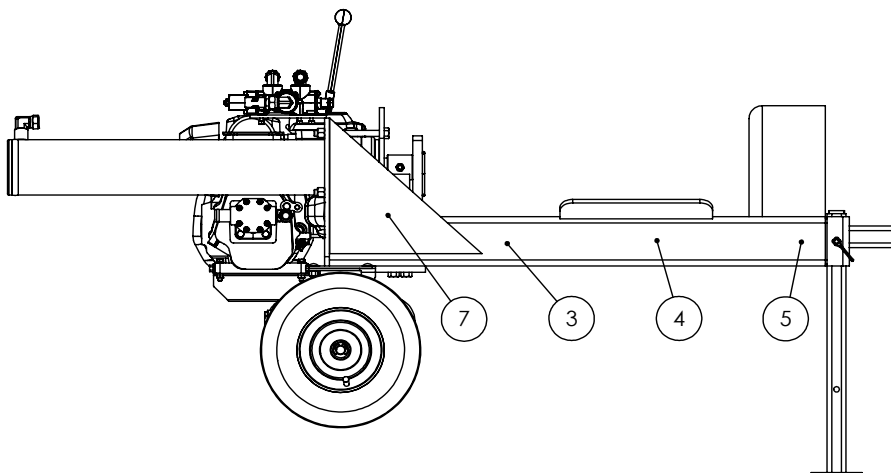
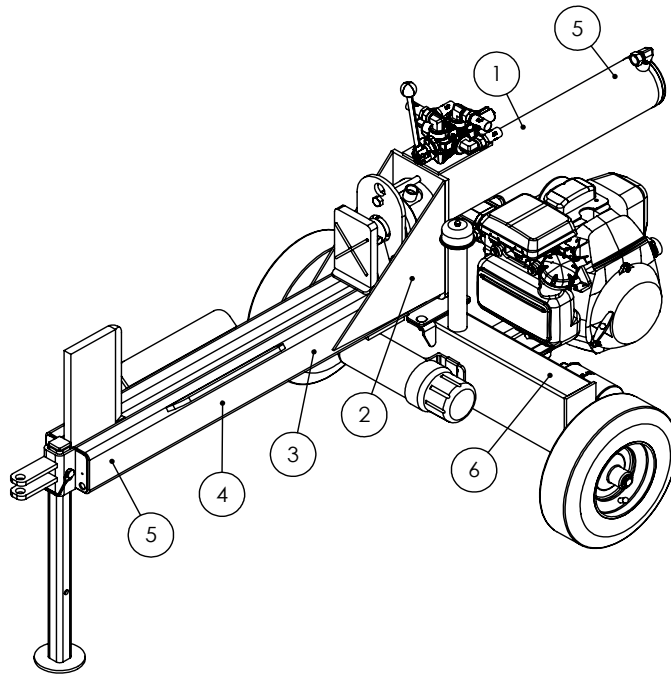

Two Panel Trailer Splitter Decals

Z94019



Z94142



Z94067



Z94056



Z94119



Z94123



Z94124





WALLENSTEIN Products Manufactured by:

EMB MFG Inc.

4144 Boomer Line
St. Clements, Ontario
Canada N0B 2M0
Phone: 1-877-695-9283
Fax: 519-699-4146
www.embmfg.com