

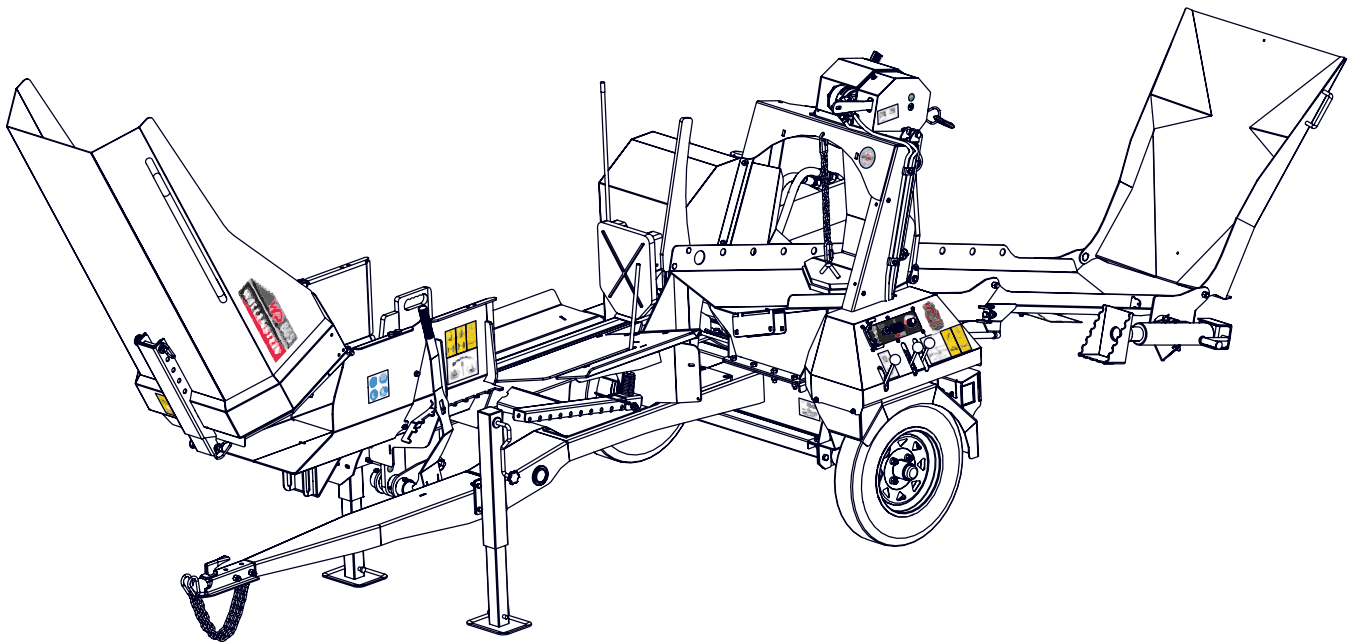

EMB Manufacturing Inc.  
4144 Boomer Line · St. Clements, On · N0B 2M0 · Canada  
Ph: (519) 699-9283 · Fax: (519) 699-4146  
[www.wallensteinequipment.com](http://www.wallensteinequipment.com)

# WP865 Wood Processor Parts Manual

S/N 2E9US1115FS660079 – 2E9US1115FS660139



Refer to the operators  
manual for safe  
operation and  
maintenance

2072T510 WP865Rev AB.Parts Manual.160516  
Rev # 131017

# Table of Contents

## Contents

<b>BOLT TORQUE .....</b>	<b>3</b>
<b>HYDRAULIC FITTING &amp; WHEEL LUG TORQUE .....</b>	<b>4</b>
<b>SPLITTER CHUTE ASS'Y.....</b>	<b>5</b>
<b>LEAD IN CHUTE ASS'Y.....</b>	<b>6</b>
<b>SPLITTER CRADLE ASS'Y .....</b>	<b>7</b>
<b>LOG CHUTE ASS'Y .....</b>	<b>8</b>
<b>RUNNING GEAR.....</b>	<b>9</b>
<b>HUB ASSEMBLY DETAIL .....</b>	<b>10</b>
<b>ENGINE &amp; PUMP ASS'Y.....</b>	<b>11</b>
<b>HYDRAULIC LINES .....</b>	<b>12</b>
<b>HYDRAULIC SPLITTER ASS'Y .....</b>	<b>13</b>
<b>HYDRAULIC VALVES .....</b>	<b>14</b>
<b>HYDRAULIC CYLINDER .....</b>	<b>15</b>
<b>HYDRAULIC CYLINDER SEAL KIT #SLK-4525.....</b>	<b>15</b>
<b>HYDRAULIC WINCH.....</b>	<b>16</b>
<b>WINCH DRUM DETAIL .....</b>	<b>17</b>
<b>WINCH FAIRLEAD DETAIL .....</b>	<b>17</b>
<b>LABELS .....</b>	<b>18</b>
<b>CONTROL PANEL LABELS .....</b>	<b>21</b>
<b>WIRING DIAGRAM .....</b>	<b>22</b>
<b>HYDRAULIC SCHEMATIC.....</b>	<b>23</b>
<b>ACCESSORIES.....</b>	<b>24</b>

## Foreword

EMB Mfg. has prepared this parts manual to assist customers in ordering quality OEM replacement parts.

Proper and regular service and replacing old, worn or broken parts with the correct Wallenstein parts are essential to prolonging the life of your Wallenstein product. Please refer to this manual before ordering any replacement parts.

All information contained in this parts manual is based on the latest product specification available at the time of printing this manual. If your product differs from the specifications contained within this manual contact EMB Mfg. for information.

EMB reserves the right to alter specifications on their products at any time.

Reproduction of this parts manual of any kind is prohibited without prior written permission from EMB Mfg.



Refer to the operators  
manual for safe  
operation and  
maintainance

For parts and information please contact your dealer. If your dealer is no longer available please go to our website: <http://www.embmfg.com> and click on "FIND A DEALER NEAR YOU" for information on a local dealer.

**Bolt Torque**

**CHECKING BOLT TORQUE**

The tables shown below give correct torque values for various bolts and capscrews. Tighten all bolts to the torques specified in chart unless otherwise noted. Check tightness of bolts periodically, using bolt torque chart as a guide. Replace hardware with the same strength bolt.

Torque figures indicated above are valid for non-greased or non-oiled threads and heads unless otherwise specified. Therefore, do not grease or oil bolts or capscrews unless otherwise specified in this manual. When using locking elements, increase torque values by 5%.

\* Torque value for bolts and capscrews are identified by their head markings.

**ENGLISH TORQUE SPECIFICATIONS**

Bolt Diameter "A"	Bolt Torque*					
	SAE 2 (N.m) (lb-ft)		SAE 5 (N.m) (lb-ft)		SAE 8 (N.m) (lb-ft)	
1/4"	8	6	12	9	17	12
5/16"	13	10	25	19	36	27
3/8"	27	20	45	33	63	45
7/16"	41	30	72	53	100	75
1/2"	61	45	110	80	155	115
9/16"	95	60	155	115	220	165
5/8"	128	95	215	160	305	220
3/4"	225	165	390	290	540	400
7/8"	230	170	570	420	880	650
1"	345	225	850	630	1320	970



**METRIC TORQUE SPECIFICATIONS**

Bolt Diameter "A"	Bolt Torque*			
	8.8 (N.m) (lb-ft)		10.9 (N.m) (lb-ft)	
M3	.5	.4	1.8	1.3
M4	3	2.2	4.5	3.3
M5	6	4	9	7
M6	10	7	15	11
M8	25	18	35	26
M10	50	37	70	52
M12	90	66	125	92
M14	140	103	200	148
M16	225	166	310	229
M20	435	321	610	450
M24	750	553	1050	774
M30	1495	1103	2100	1550
M36	2600	1917	3675	2710

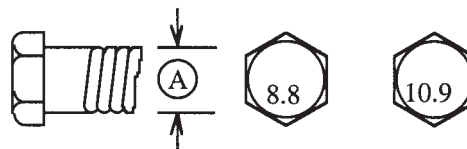

**Hydraulic Fitting Torque**

**Tightening Flare Type Tube Fittings \***

1. Check flare and flare seat for defects that might cause leakage.
2. Align tube with fitting before tightening.
3. Lubricate connection and hand tighten swivel nut until snug.
4. To prevent twisting the tube(s), use two wrenches. Place one wrench on the connector body and with the second tighten the swivel nut to the torque shown.

Tube Size OD (in.)	Nut Size Across Flats (in.)	Torque Value*		Recommended Turns To Tighten (After Finger Tightening)	
		(N.m)	(lb-ft)	(Flats)	(Turn)
3/16	7/16	8	6	1	1/6
1/4	9/16	12	9	1	1/6
5/16	5/8	16	12	1	1/6
<b>3/8</b>	<b>11/16</b>	<b>24</b>	<b>18</b>	<b>1</b>	<b>1/6</b>
1/2	7/8	46	34	1	1/6
5/8	1	62	46	1	1/6
3/4	1-1/4	102	75	3/4	1/8
7/8	1-3/8	122	90	3/4	1/8

The torque values shown are based on lubricated connections as in reassembly.

**Wheel Lug Torque**

It is extremely important safety procedure to apply and maintain proper wheel mounting torque on your trailer axle. Torque wrenches are the best method to assure the proper amount of torque is being applied to a fastener.

Wheel lugs should be torqued before first road use and after each wheel removal. Check and re torque after the first 16Km (10 miles), 40Km (25 miles), and again at 80Km (50 miles). Check periodically thereafter.

Note: Wheel lugs must be applied and maintained at the proper torque levels to prevent loose wheels, broken studs, and possible dangerous separation of wheels from your axle.

- Start all lugs by hand to prevent cross threading.
- Tighten lugs in sequence, per wheel lug torque sequence chart.
- The tightening of the fasteners should be done in stages. Following the recommended sequence, tighten fasteners per wheel torque requirements chart.

**Wheel Torque Requirements**

Wheel Size	Torque Unit	1st Stage	2nd Stage	3rd Stage
8"	ft-lbs	12 - 20	30 - 35	45 - 55
	Nm	16 - 26	39 - 45.5	58.5 - 71.5
12"	ft-lbs	20 - 25	35 - 40	50 - 60
	Nm	26 - 32.5	45.5 - 52	65 - 78
13"	ft-lbs	20 - 25	35 - 40	50 - 60
	Nm	26 - 32.5	45.5 - 52	65 - 78
14"	ft-lbs	20 - 25	50 - 60	90 - 120
	Nm	26 - 32.5	65 - 78	117 - 156
15"	ft-lbs	20 - 25	50 - 60	90 - 120
	Nm	26 - 32.5	65 - 78	117 - 156
16"	ft-lbs	20 - 25	50 - 60	90 - 120
	Nm	26 - 32.5	65 - 78	117 - 156

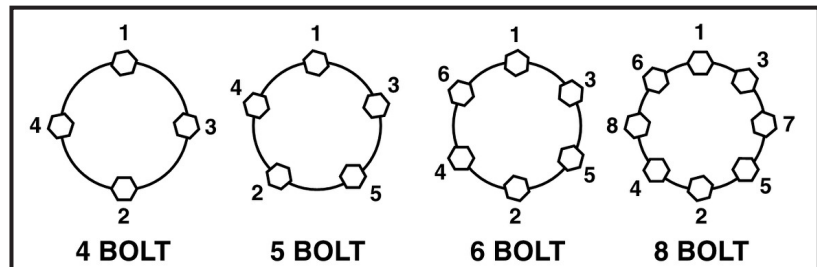

**Wheel Lug Torque Sequence**

**Splitter Chute Ass'y**

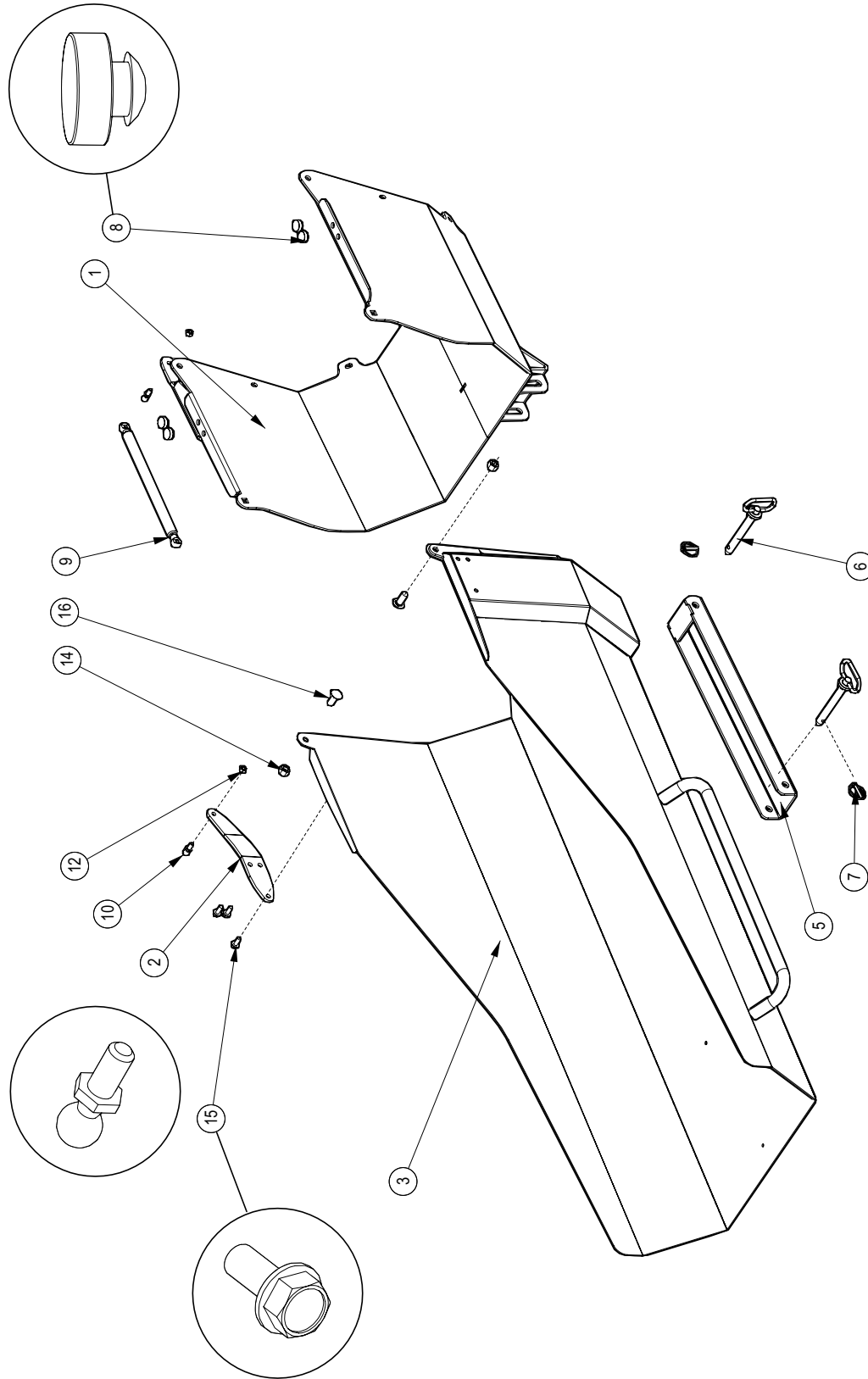

Item	Part Number	Description	Qty
9	Z34203	Gas Spring, 10mm x 8.44 Stroke	1
10	Z34204	Ball Stud 13mm x 5/16	2
12	Z72221	Hex Lock Nut, 5/16NC	2
14	Z72251	Hex Lock Nut, 1/2NC	2
15	Z76121	Flange Bolt, 5/16NC x 3/4	3
16	Z76259	Carriage Bolt, 1/2NC x 1-1/4	2

Item	Part Number	Description	Qty
1	2019W993	Chute, Extension	1
2	2071L188	Plate, Spring Mount	1
3	2071W104	Splitter Chute	1
5	2071W114	Chute Adjuster	1
6	Z11232	Hitch Pin 5/8 x 4-1/4	2
7	Z12110	Latch Pin 3/16	2
8	Z19909	Rubber Bumper 7/16 x 1	4

**Lead In Chute Ass'y**

BOM ID	Part No.	Description	Qty
17	2071L503	Plate, Remote Start	1
18	2071W101	Chute, Lead In	1
19	2071W118	Chute, Bottom	1
20	2071W122	Foot, Jack	2
21	2071W505	Cover, Valve	1
22	2071W534	Dust Guard	1
23	5081A100	Hydraulic Winch Assembly	1
24	Z12441	Snap Lock Pin, 1/2" x 4-1/2"	2
25	Z34204	Ball Stud, 13mm x 5/16NC	2

BOM ID	Part No.	Description	Qty
26	Z71330	Hex Bolt, 3/8NC x 3"	2
27	Z72221	Hex Lock Nut, 5/16NC	2
28	Z72231	Hex Lock Nut, 3/8NC	2
29	Z72251	Hex Lock Nut, 1/2NC	4
30	Z76121	Flange Bolt, 5/16NC x 3/4"	5
31	Z76259	Carriage Bolt, 1/2NC x 1-1/4"	4
32	Z78301	Machine Screw, 1/4NC x 3/4"	6
33	Z91515	Trailer Jack, Side Wind x 2000lbs No Foot	2

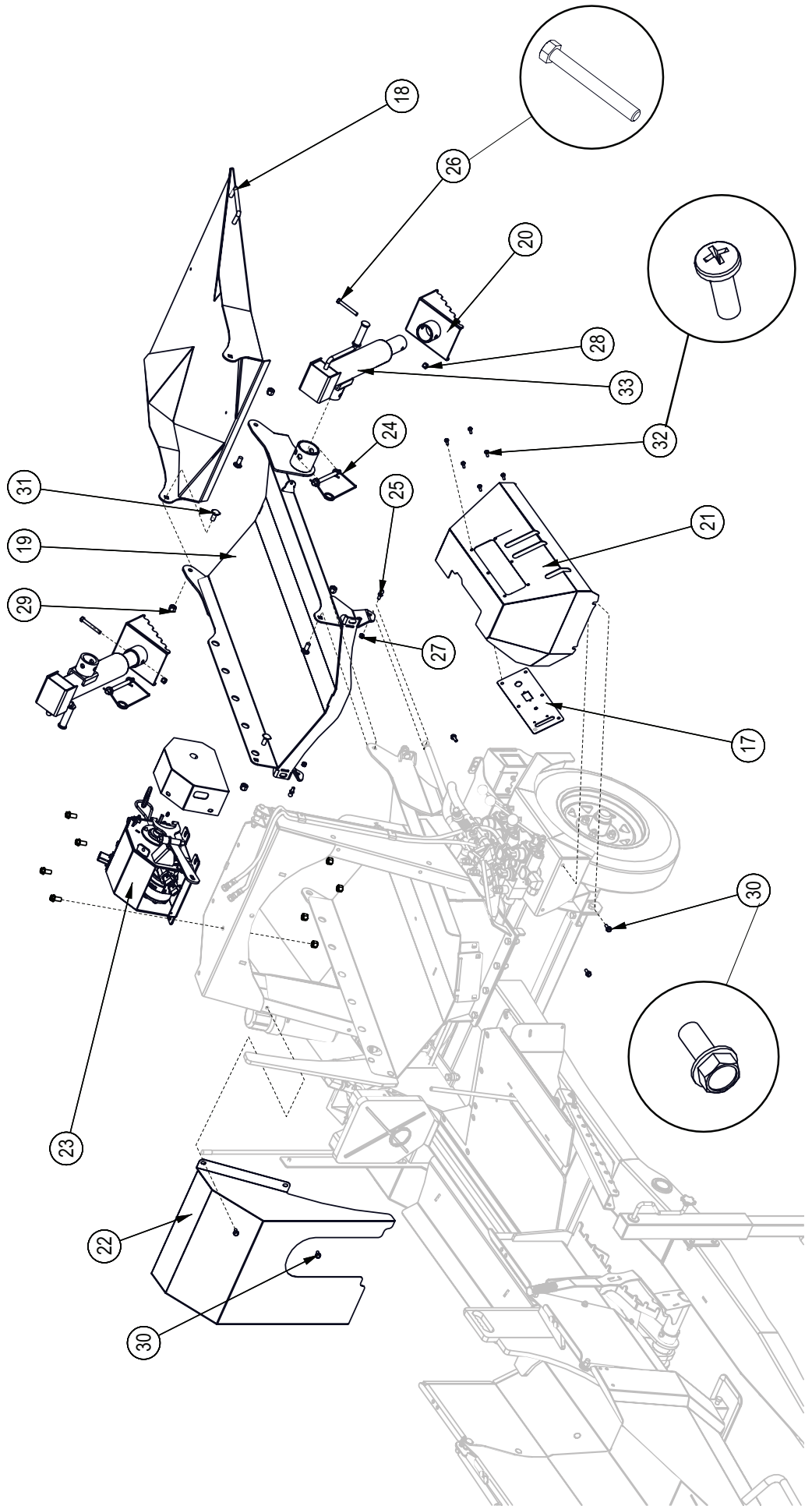

Log Hold Down Ass'y

BOM ID	Part Number	Description	Qty
24	2071W102	Hold Down Bottom	1
25	2071W110	Log Hold Down Long	1
26	2071W112	Pin, Log Hold Down	1
27	2071W136	Pin, Log Hold Down	1
28	Z29202	Grease Zerk 1/4NF	4
29	Z72221	Hex Lock Nut, 5/16NC	1

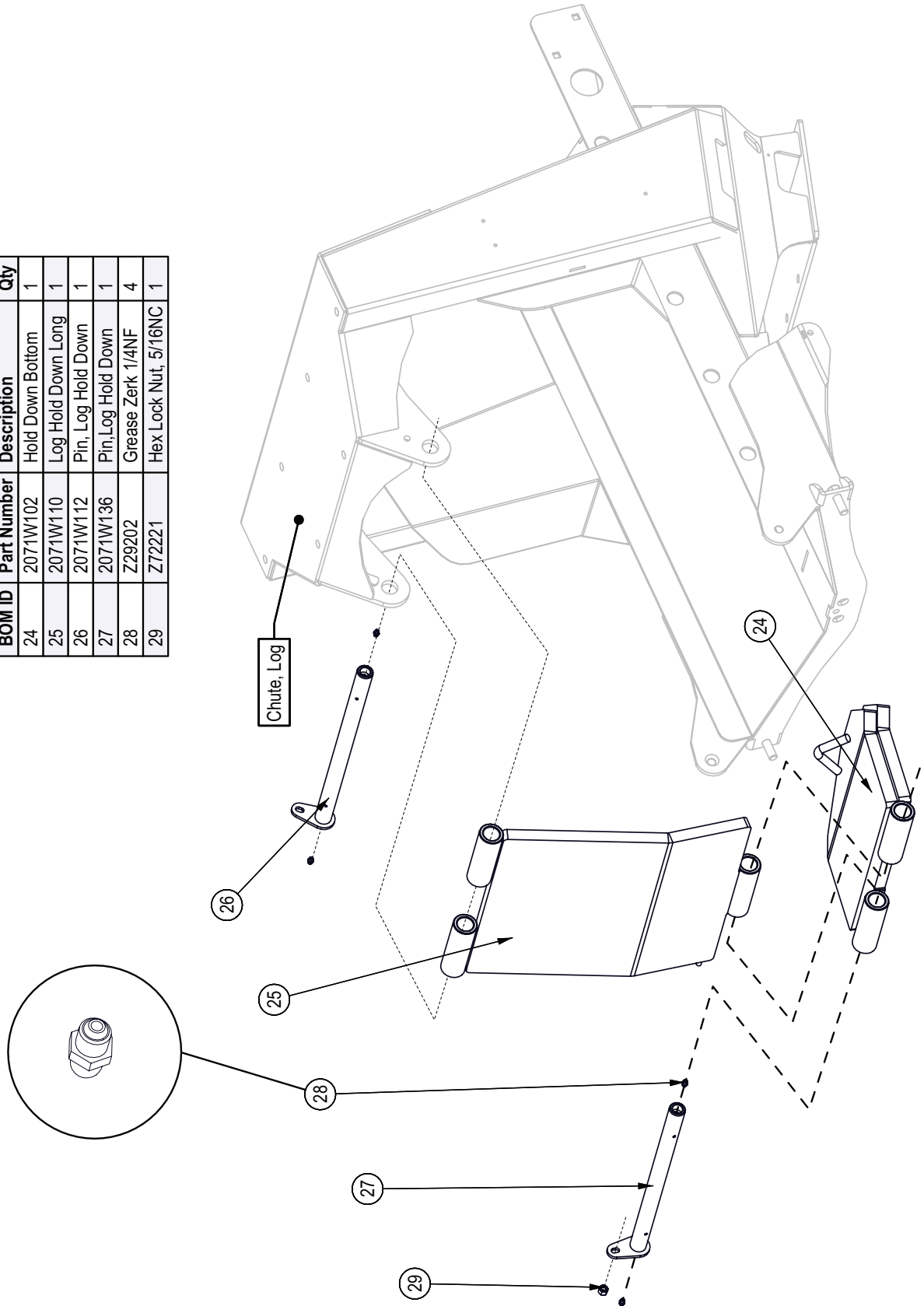



**Splitter Cradle Ass'y**

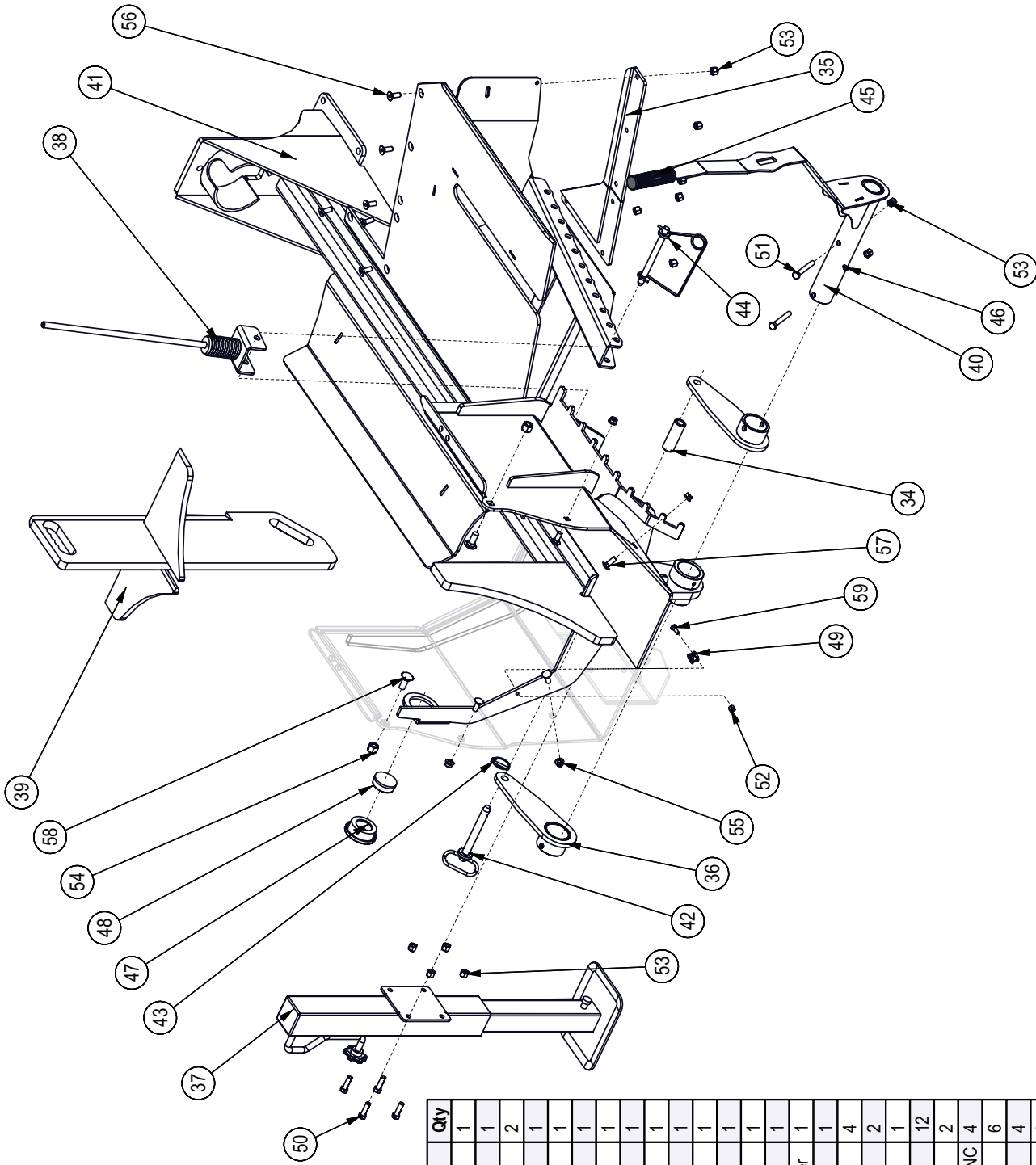

BOM ID	Part No.	Description	Qty
34	2071M123	Roller Wedge Lift	1
35	2071S126	Edge, Log Table	1
36	2071W111	Arm Wedge Lifter	2
37	2071W116	Drop Leg Jack Assembly	1
38	2071W190	Log Stop Whip	1
39	2071W532	Wedge 4 Way	1
40	2071W533	Wedge Position Handle	1
41	2072W609	Splitter	1
42	Z11232	Hitch Pin, 5/8" x 4-1/4"	1
43	Z12110	Lynch Pin, 3/16"	1
44	Z12441	Snap Lock Pin, 1/2" x 4-1/2"	1
45	Z19321	Grip, 1" x 5"	1
46	Z29202	Grease Zerk 1/4NF	1
47	Z61202	Round Grommet 2" Lamp	1
48	Z61205	Round Marker Lamp 2" Amber	1
49	Z62819	Rubberized Wire Clamp, 1/2"	1
50	Z71312	Hex Bolt, 3/8NC x 1-1/4"	4
51	Z71330	Hex Bolt, 3/8NC x 3"	2
52	Z72211	Hex Lock Nut, 1/4NC	1
53	Z72231	Hex Lock Nut, 3/8NC	12
54	Z72251	Hex Lock Nut, 1/2NC	2
55	Z72531	Serrated Flange Locknut, 3/8NC	4
56	Z75233	FHCS, 3/8NC x 1"	6
57	Z76231	Carriage Bolt, 3/8NC x 1"	4
58	Z76259	Carriage Bolt, 1/2NC x 1-1/4"	2
59	Z78301	Machine Screw, 1/4NC x 3/4"	1



**Log Chute Ass'y**

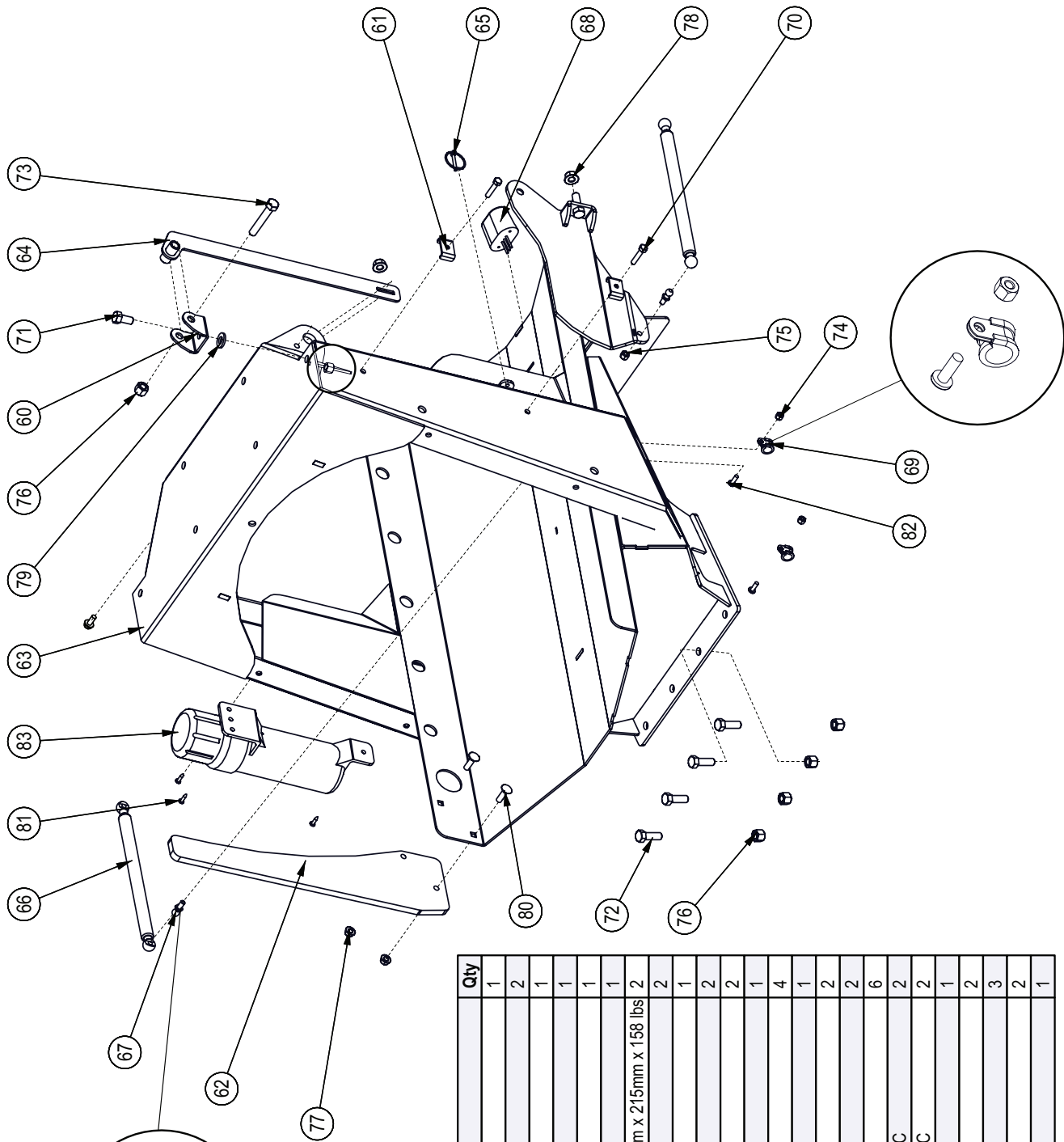

BOM ID	Part No.	Description	Qty
60	2071L123	Clevis, Latch Mount	1
61	2071L504	Hose Clamp, 2x 1/4"	2
62	2071S506	Saw Guide	1
63	2071W115	Chute, Log	1
64	2071W121	Arm, Log Chute Lock	1
65	Z12110	Lynch Pin, 3/16"	1
66	Z34203	Gas Spring, 10mm OD x 540mm x 215mm x 158 lbs	2
67	Z34204	Ball Stud, 13mm x 5/16NC	2
68	Z61301	License Lamp	1
69	Z62819	Rubberized Wire Clamp, 1/2"	2
70	Z71215	Hex Bolt, 5/16NC x 1-1/2"	2
71	Z71510	Hex Bolt, 1/2NC x 1"	1
72	Z71515	Hex Bolt, 1/2NC x 1-1/2"	4
73	Z71530	Hex Bolt, 1/2NC x 3"	1
74	Z72211	Hex Lock Nut, 1/4NC	2
75	Z72221	Hex Lock Nut, 5/16NC	2
76	Z72251	Hex Lock Nut, 1/2NC	6
77	Z72531	Serrated Flange Locknut, 3/8NC	2
78	Z72551	Serrated Flange Locknut, 1/2NC	2
79	Z73151	SAE Washer, 1/2"	1
80	Z76232	Carriage Bolt, 3/8NC x 1-1/4"	2
81	Z76712	Self-tapping Screw, #10 x 3/4"	3
82	Z78301	Machine Screw, 1/4NC x 3/4"	2
83	Z966503	Manual Tube 3-1/2 Short	1

**Running Gear**

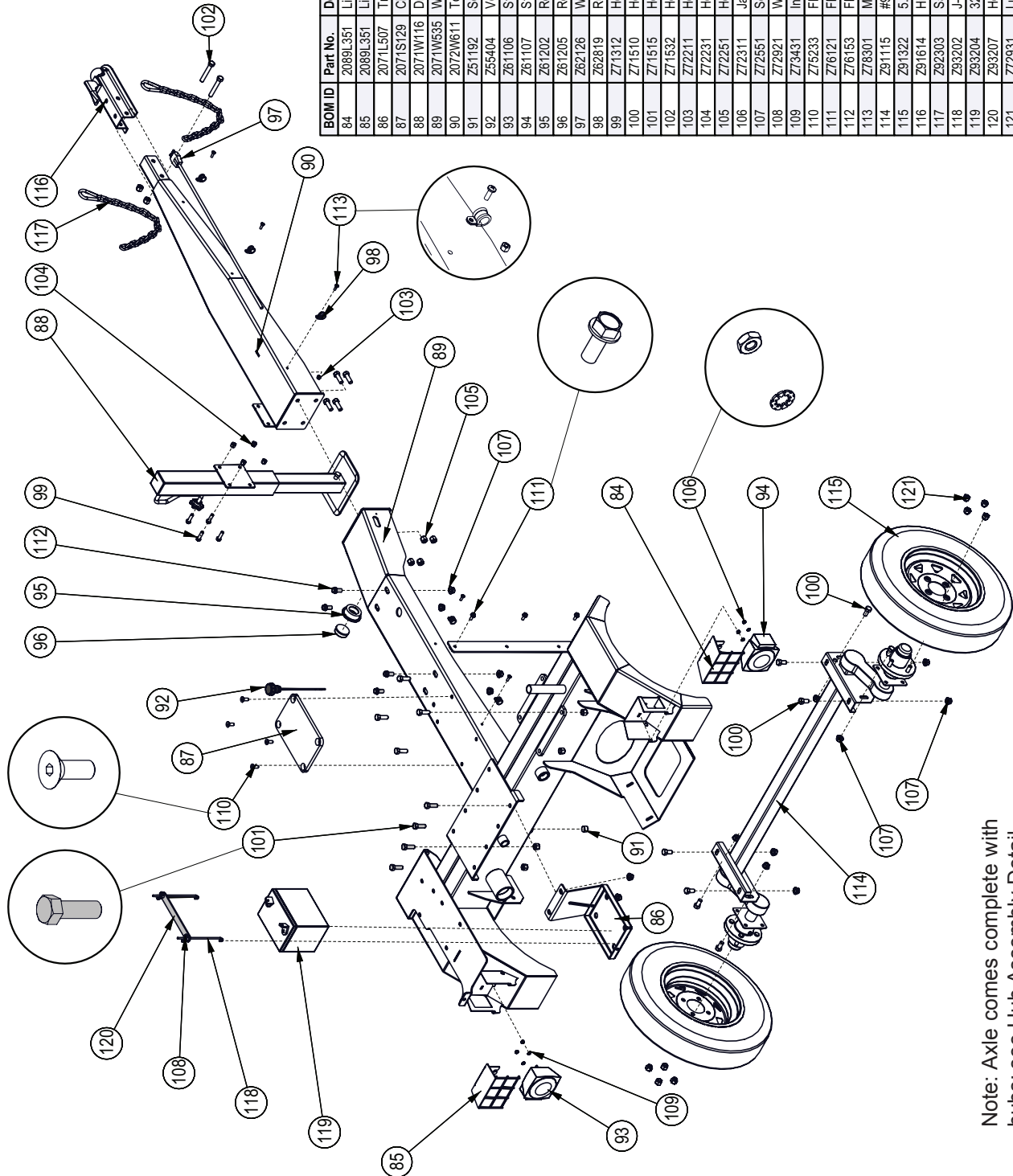

BOM ID	Part No.	Description	Qty
84	2089L351	Light Guard	1
85	2089L351	Light Guard	1
86	2071L507	Tray, Battery	1
87	2071S129	Chain Bumper	1
88	2071W116	Drop Leg Jack Assembly	1
89	2071W535	Weldment, WP830 Tank Base	1
90	2072W611	Tongue	1
91	251192	Socket Plug, MP 08	1
92	Z55404	Vented Plug Dipstick x 9"	1
93	Z61106	Stop, Turn, Tail Light LH	1
94	Z61107	Stop, Turn, Tail Light RH	1
95	Z61202	Round Grommet 2" Lamp	1
96	Z61205	Round Marker Lamp 2", Amber	1
97	Z62126	WP800 Series Lights Harness	1
98	Z62819	Rubberized Wire Clamp, 1/2"	5
99	Z71312	Hex Bolt, 3/8NC x 1-1/4"	4
100	Z71510	Hex Bolt, 1/2NC x 1"	8
101	Z71515	Hex Bolt, 1/2NC x 1-1/2"	12
102	Z71532	Hex Bolt, 1/2NC x 3-1/4"	2
103	Z72211	Hex Lock Nut, 1/4NC	5
104	Z72231	Hex Lock Nut, 3/8NC	4
105	Z72251	Hex Lock Nut, 1/2NC	14
106	Z72311	Jam Nut, 1/4NC	4
107	Z72551	Serrated Flange Locknut, 1/2NC	14
108	Z72921	Wing Nut, 1/4NC	2
109	Z73431	Int - Ext Tooth Washer, 1/4"	4
110	Z75233	FHCS, 3/8NC x 1"	4
111	Z76121	Flange Bolt, 5/16NC x 3/4"	3
112	Z76153	Flange Bolt, 1/2NC x 1"	4
113	Z78301	Machine Screw, 1/4NC x 3/4"	5
114	Z91115	#9 Full Flex Axle, 2200lbs x 54" HF	1
115	Z91322	5-30-12 LRC USA Trail 4044" (E-Marked)	2
116	Z91614	Hitch Coupler, 2" Ball x 2" x 3500lbs	1
117	Z92303	Safety Chain 1/4 x 2'	2
118	Z93202	J-Hook 1/4 x 7	2
119	Z93204	325 CCA Battery	1
120	Z93207	Hold-Down Strap, 1 x 8-1/2	1
121	Z72931	Lug Nut, 1/2NF	8

Note: Axle comes complete with hubs: see Hub Assembly Detail.

**Hub Assembly Detail**

Item	Part Number	Description	Qty
123	Z12322	2" x 3/16" Split Pin	1
124	Z23202	L44649 Cone, L44610 Cup	2
125	Z28302	Double Lip Seal 1-1/16 Spindle	1
126	Z29201	Grease Fitting, 1/8NPT	1
127	Z72930	Lug Nut 1/2NF	4
128	Z91201	1000# 4-Bolt Hub	1
129	Z91801	Dust Cap 1.98 Bore	1
130	Z72691	1" Castle Nut	1

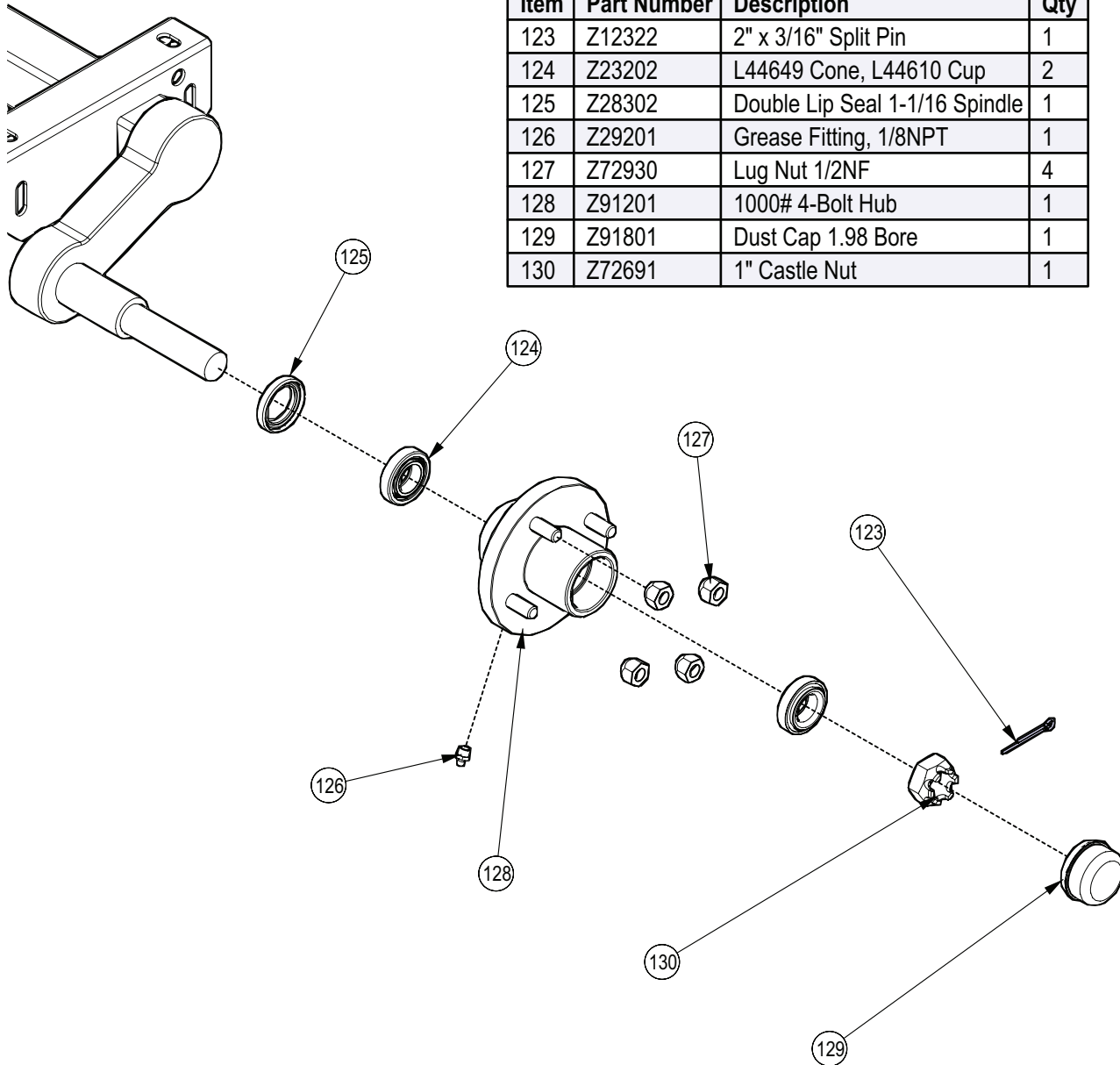

BOM ID	Part No.	Description	Qty
131	2071L545	Plate, Engine Mount	1
132	Z46404	Shaft Coupler L095 x 1	1
133	Z46405	Coupler Spider L095	1
134	Z46419	Shaft Coupler L095 x 5/8	1
135	Z46522	Key, 3/16 x 3/16 x 1	1
136	Z46533	Key, 1/4 x 1/4 x 1	1
137	Z47712	Subaru EX400DP 14hp Engine	1
138	Z47906	Keyswitch for Subaru EX400	1
139	Z51185	Straight, MHB x MP 2020	1
140	Z51186	Straight, MHB x MP 2016	1
141	Z52408	Suction Hose, 1-1/4" x 30"	1
142	Z53206	Two-Stage Pump, 22GPM	1
143	Z53806	Pump Mount, PM-14SU	1
144	Z55102	Suction Strainer, MP32	1
145	Z64611	Hour Meter, E-Mech DC	1
146	Z71274	Hex Bolt, 5/16NF x 1"	4
147	Z71310	Hex Bolt, 3/8NC x 1"	2
148	Z71315	Hex Bolt, 3/8NC x 1-1/2"	4
149	Z72521	Serrated Flange Locknut, 5/16NC	7
150	Z72531	Serrated Flange Locknut, 3/8NC	4
151	Z79404	Hose Clamp, SAE #24 (2")	2
152	Z79933	Isolator, 1-9/16" Dia x 1" x 5/16NC	4
153	Z92115	Remote Choke Cable 68"	1
154	Z92116	Remote Throttle Cable 66"	1

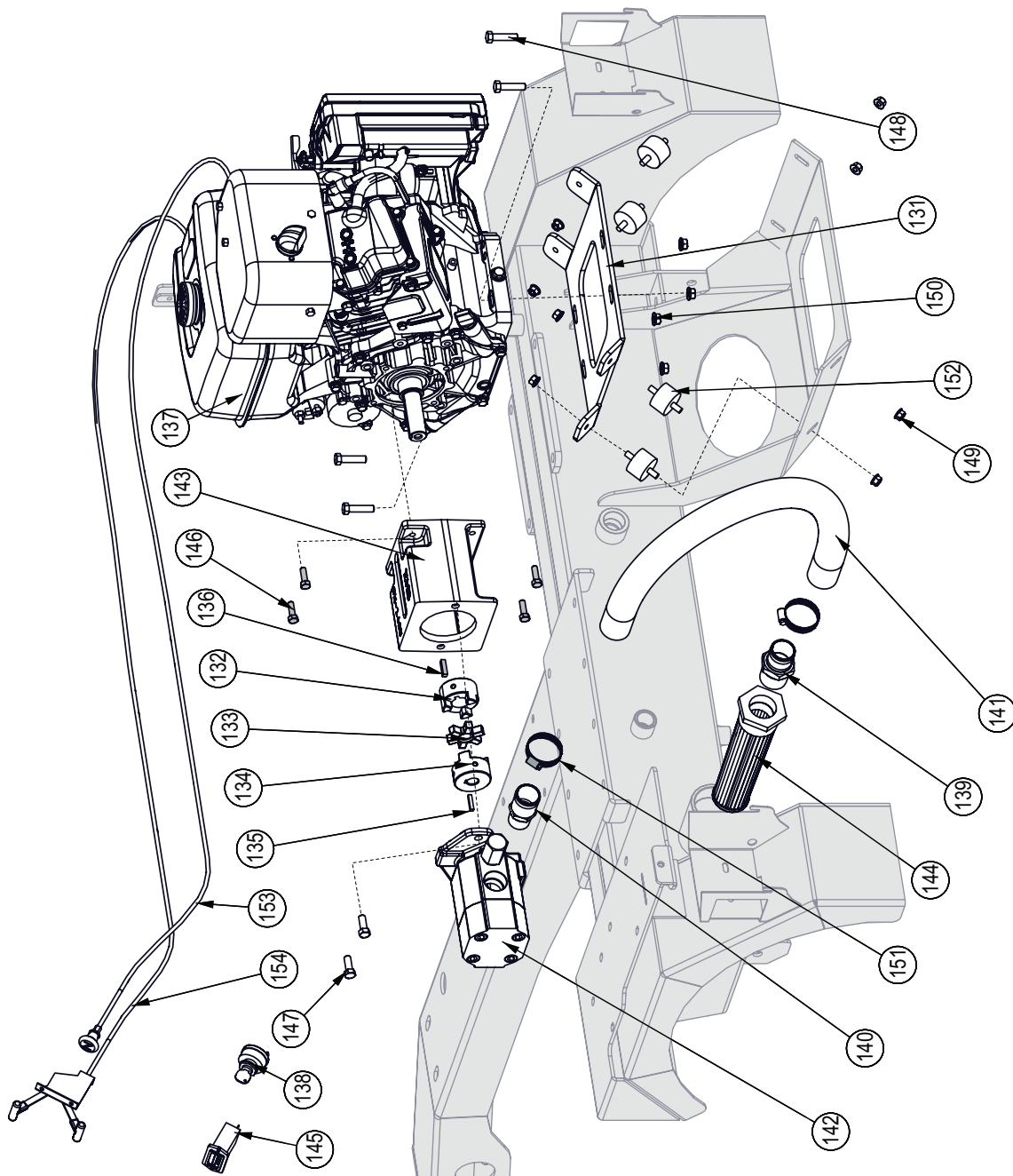

Engine & Pump Ass'y



**Hydraulic Splitter Ass'y**

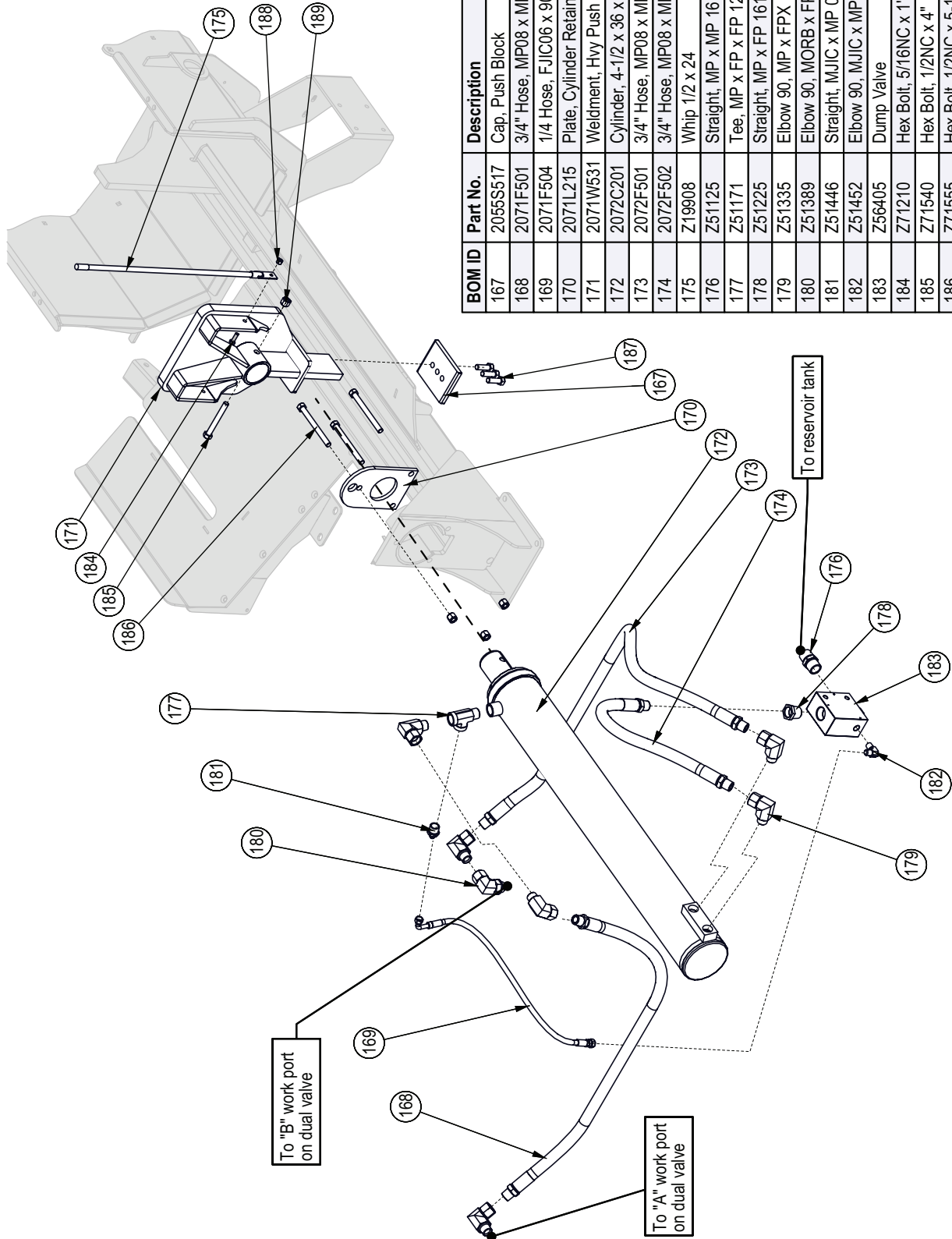

BOM ID	Part No.	Description	Qty
167	2055S517	Cap, Push Block	1
168	2071F501	3/4" Hose, MP08 x MP08 x 42"	1
169	2071F504	1/4 Hose, FJIC06 x 90FJIC06 x 25"	1
170	2071L215	Plate, Cylinder Retaining	1
171	2071W631	Weldment, Hvy Push Block	1
172	2072C201	Cylinder, 4-1/2 x 36 x 2-1/2	1
173	2072F501	3/4" Hose, MP08 x MP08 x 68"	1
174	2072F502	3/4" Hose, MP08 x MP08 x 40"	1
175	Z19908	Whip 1/2 x 24	1
176	Z51125	Straight, MP x MP 1616	1
177	Z51171	Tee, MP x FP x FP 121212	1
178	Z51225	Straight, MP x FP 1612	1
179	Z51335	Elbow 90, MP x FPX 1212	6
180	Z51389	Elbow 90, MORB x FFX 1212	1
181	Z51446	Straight, MJIC x MP 0612	1
182	Z51452	Elbow 90, MJIC x MP 0606	1
183	Z56405	Dump Valve	1
184	Z71210	Hex Bolt, 5/16NC x 1"	1
185	Z71540	Hex Bolt, 1/2NC x 4"	1
186	Z71555	Hex Bolt, 1/2NC x 5-1/2"	3
187	Z71576G8	Hex Bolt, 1/2NF x 1-1/2" G8	3
188	Z72221	Hex Lock Nut, 5/16NC	1
189	Z72251	Hex Lock Nut, 1/2NC	4



Hydraulic Valves

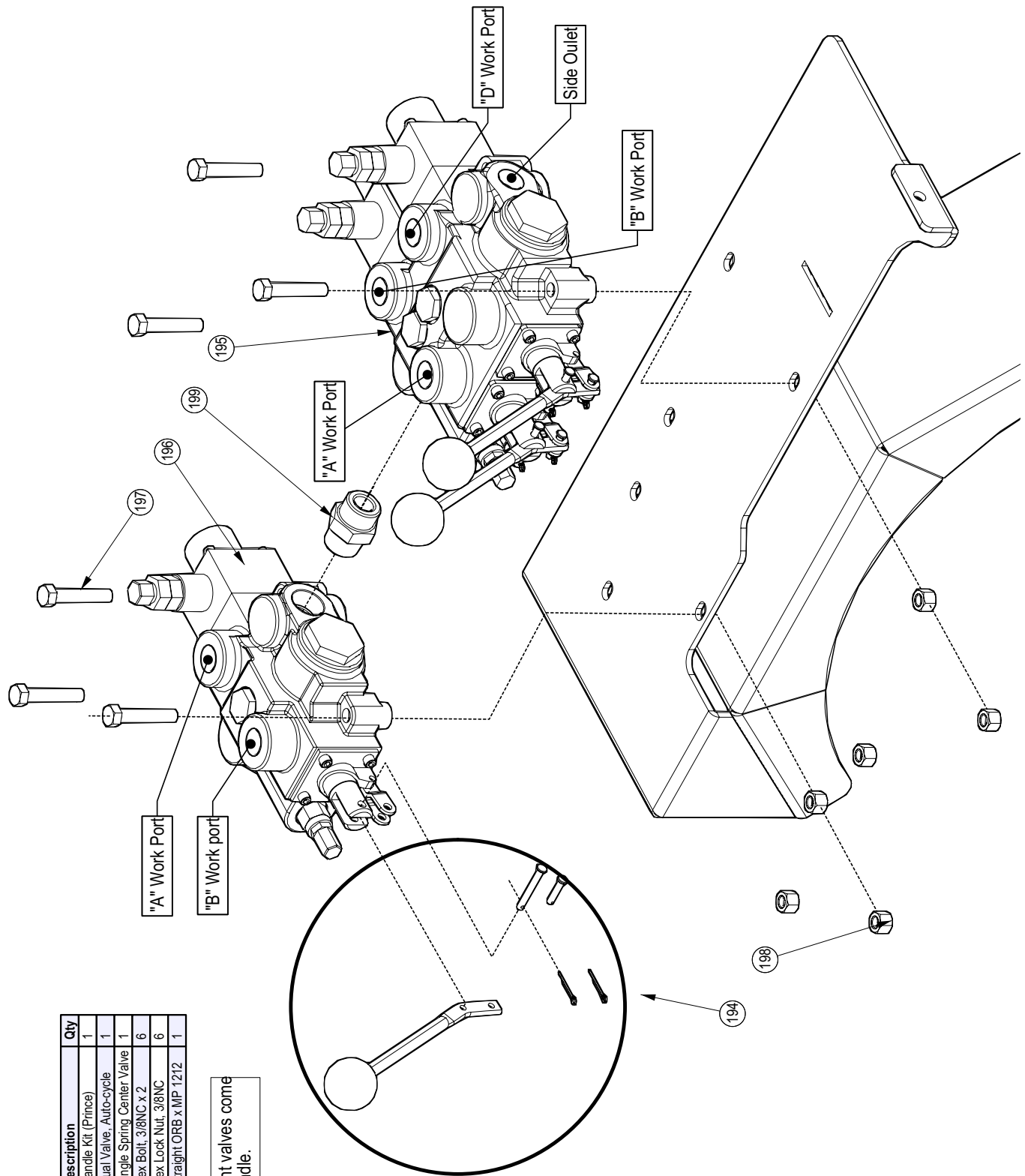

Item	Part Number	Description	Qty
194	660150004	Handle Kit (Prince)	1
195	Z56213	Dual Valve, Auto-cycle	1
196	Z56214	Single Spring Center Valve	1
197	Z71320	Hex Bolt, 3/8NC x 2	6
198	Z72231	Hex Lock Nut, 3/8NC	6
199	Z51613	Straight ORB x MP 1212	1

Note: Replacement valves come complete with handle.



**Hydraulic Cylinder**

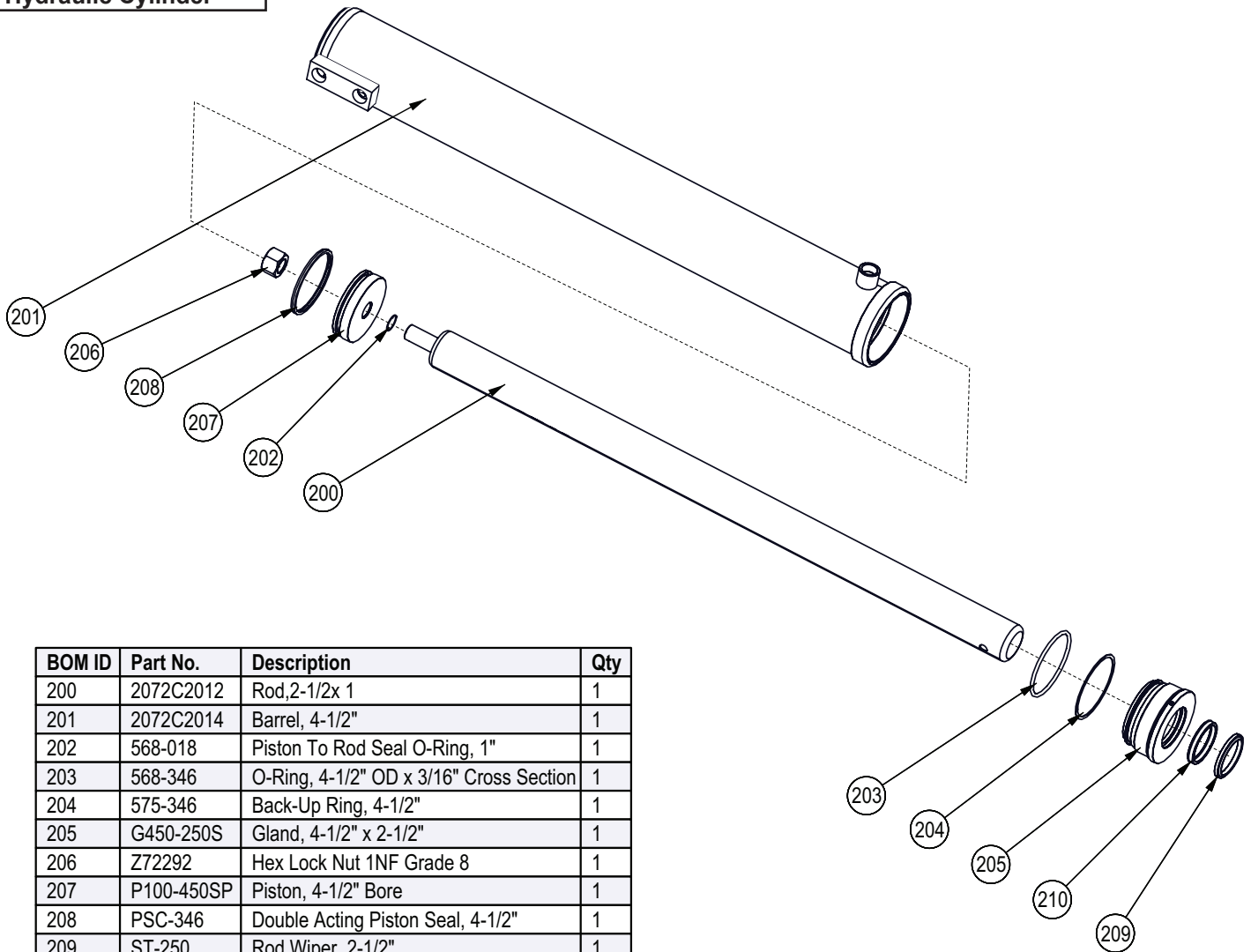

BOM ID	Part No.	Description	Qty
200	2072C2012	Rod, 2-1/2x 1	1
201	2072C2014	Barrel, 4-1/2"	1
202	568-018	Piston To Rod Seal O-Ring, 1"	1
203	568-346	O-Ring, 4-1/2" OD x 3/16" Cross Section	1
204	575-346	Back-Up Ring, 4-1/2"	1
205	G450-250S	Gland, 4-1/2" x 2-1/2"	1
206	Z72292	Hex Lock Nut 1NF Grade 8	1
207	P100-450SP	Piston, 4-1/2" Bore	1
208	PSC-346	Double Acting Piston Seal, 4-1/2"	1
209	ST-250	Rod Wiper, 2-1/2"	1
210	UI8-250-37B	U-Cup, 2-1/2" x 3/8"	1

VIEW SHOWS PROPER SEAL ORIENTATION

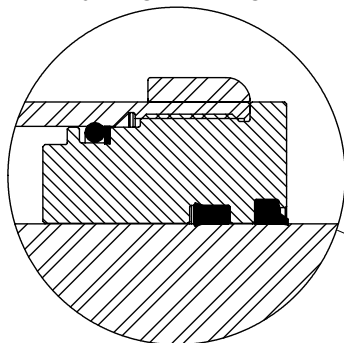

**Hydraulic Cylinder Seal Kit #SLK-4525**

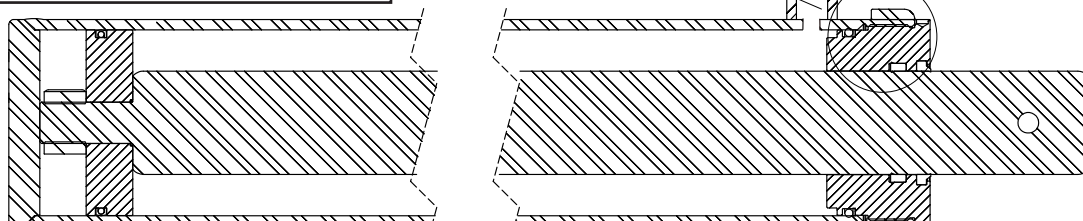

Hydraulic Winch

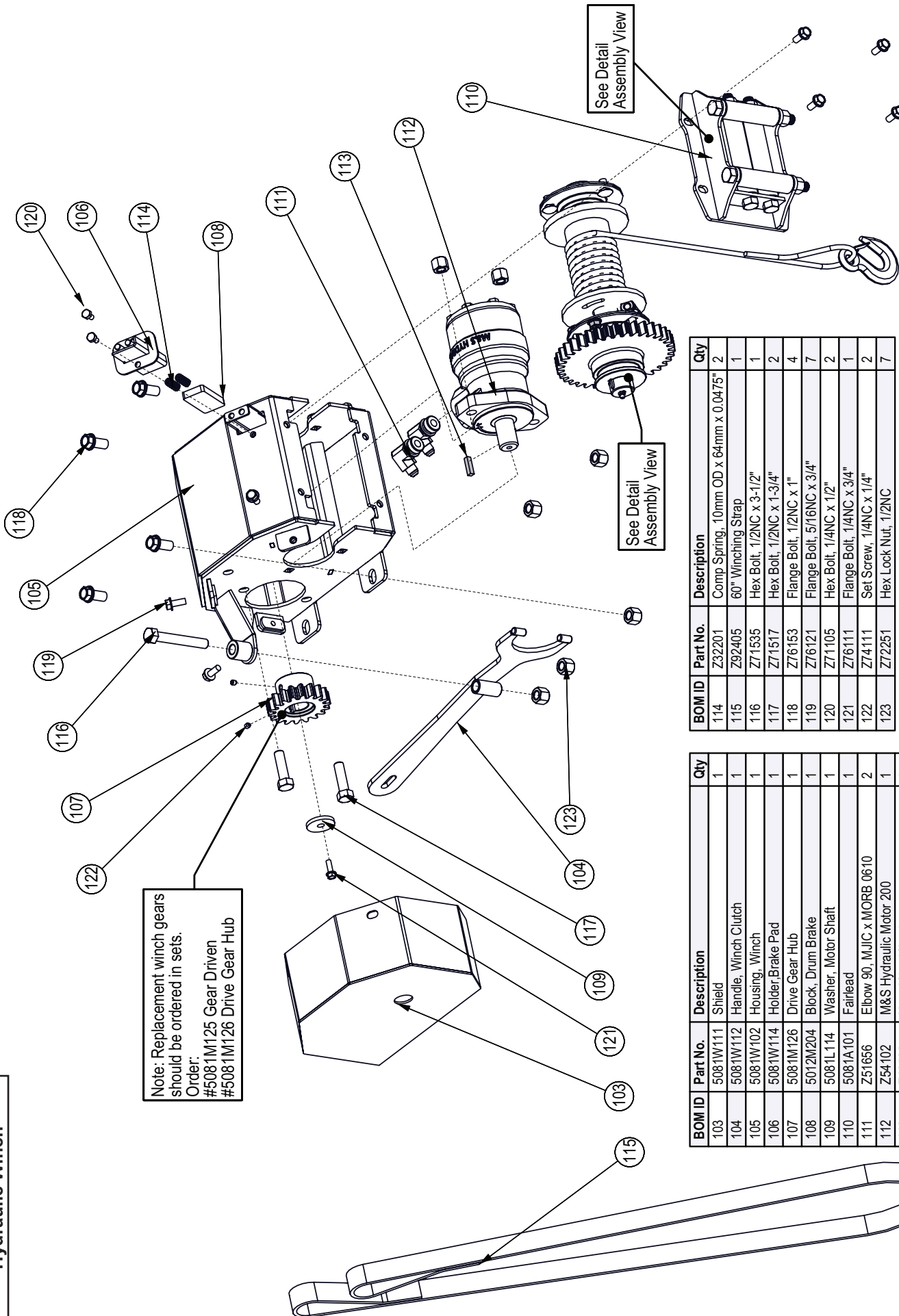

Note: Replacement winch gears should be ordered in sets.  
 Order:  
 #5081M125 Gear Driven  
 #5081M126 Drive Gear Hub

BOM ID	Part No.	Description	Qty
114	Z32201	Comp Spring, 10mm OD x 64mm x 0.0475"	2
115	Z92405	60" Winching Strap	1
116	Z71535	Hex Bolt, 1/2NC x 3-1/2"	1
117	Z71517	Hex Bolt, 1/2NC x 1-3/4"	2
118	Z76153	Flange Bolt, 1/2NC x 1"	4
119	Z76121	Flange Bolt, 5/16NC x 3/4"	7
120	Z71105	Hex Bolt, 1/4NC x 1/2"	2
121	Z76111	Flange Bolt, 1/4NC x 3/4"	1
122	Z74111	Set Screw, 1/4NC x 1/4"	2
123	Z72251	Hex Lock Nut, 1/2NC	7

BOM ID	Part No.	Description	Qty
103	5081W111	Shield	1
104	5081W112	Handle, Winch Clutch	1
105	5081W102	Housing, Winch	1
106	5081W114	Holder/Brake Pad	1
107	5081M126	Drive Gear Hub	1
108	5012M204	Block, Drum Brake	1
109	5081L114	Washer, Motor Shaft	1
110	5081A101	Fairlead	1
111	Z51656	Elbow 90, M,JIC x MORB.0610	2
112	Z54102	M&S Hydraulic Motor 200	1
113	Z46533	Key, 1/4 x 1/4 x 1	1

**Winch Drum Detail**

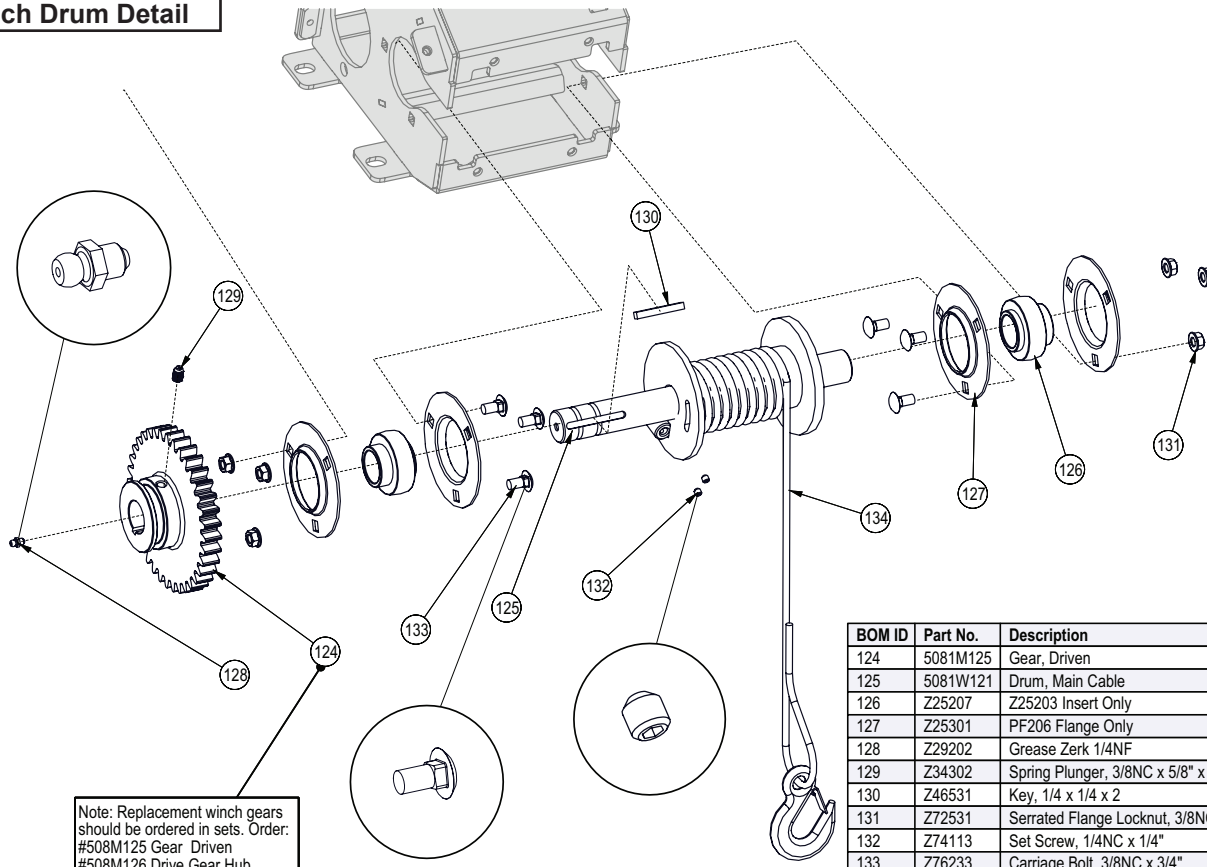

Note: Replacement winch gears should be ordered in sets. Order: #508M125 Gear Driven #508M126 Drive Gear Hub

BOM ID	Part No.	Description	Qty
124	5081M125	Gear, Driven	1
125	5081W121	Drum, Main Cable	1
126	Z25207	Z25203 Insert Only	2
127	Z25301	PF206 Flange Only	4
128	Z29202	Grease Zerk 1/4NF	1
129	Z34302	Spring Plunger, 3/8NC x 5/8" x 21 lbs	1
130	Z46531	Key, 1/4 x 1/4 x 2	1
131	Z72531	Serrated Flange Locknut, 3/8NC	6
132	Z74113	Set Screw, 1/4NC x 1/4"	2
133	Z76233	Carriage Bolt, 3/8NC x 3/4"	6
134	Z92112	Synthetic Winch Rope 1/4 x 50' with Hook	1

**Winch Fairlead Detail**

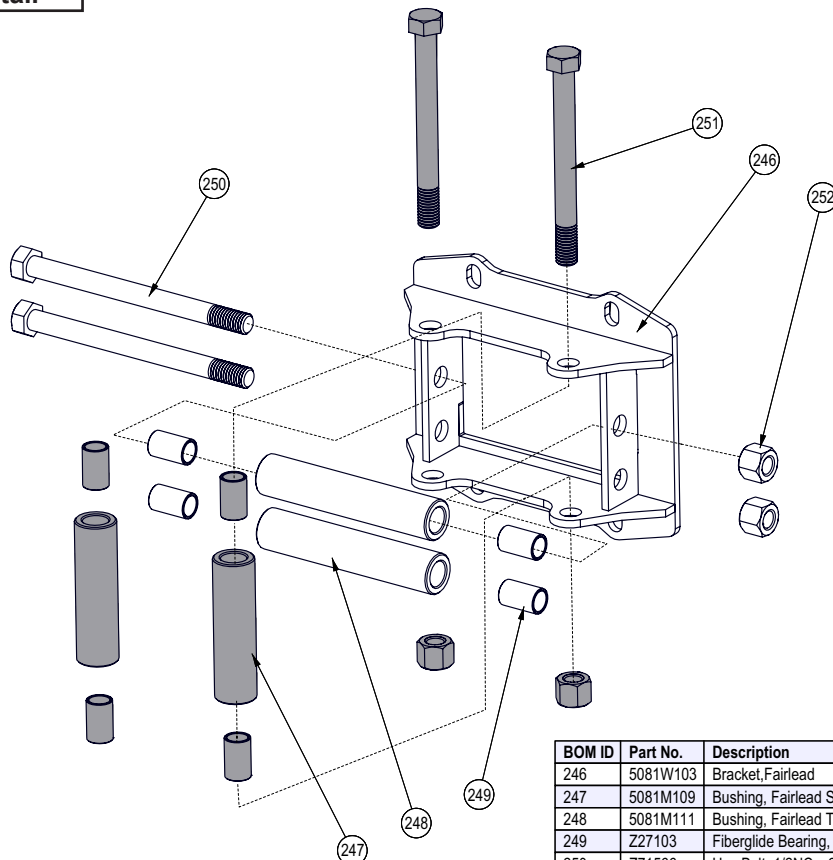

BOM ID	Part No.	Description	Qty
246	5081W103	Bracket, Fairlead	1
247	5081M109	Bushing, Fairlead Side	2
248	5081M111	Bushing, Fairlead Top	2
249	Z27103	Fiberglide Bearing, 1/2" ID x 1" long x 1/16" wall	8
250	Z71566	Hex Bolt, 1/2NC x 6-1/4" x 5-1/4" Shank	2
251	Z71567	Hex Bolt, 1/2NC x 5" x 4" Shank	2
252	Z72251	Hex Lock Nut, 1/2NC	4

Labels



Z94203 x 1



Z94242 x 1



Z94124 x 1



Z94123 x 1



Z94119 x 1

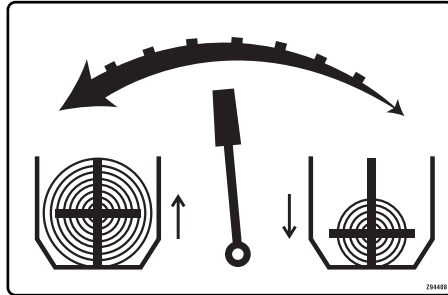

Z94408 x 1

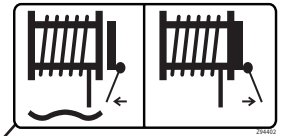

Z94402 x 1



Z94243 x 1



Z94426 x 1



Z94426 x 2



Z946129 x 1

See Control Panel Layout on Page 21

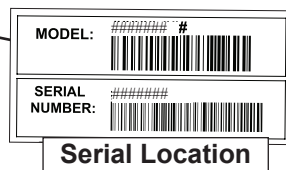
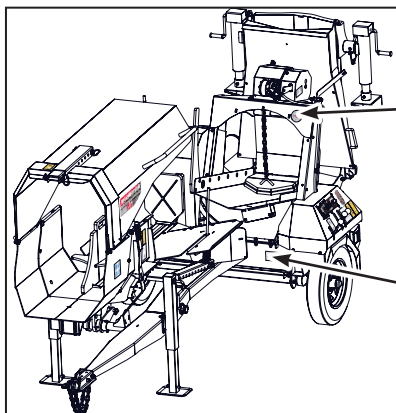
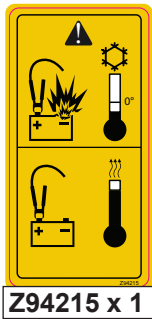

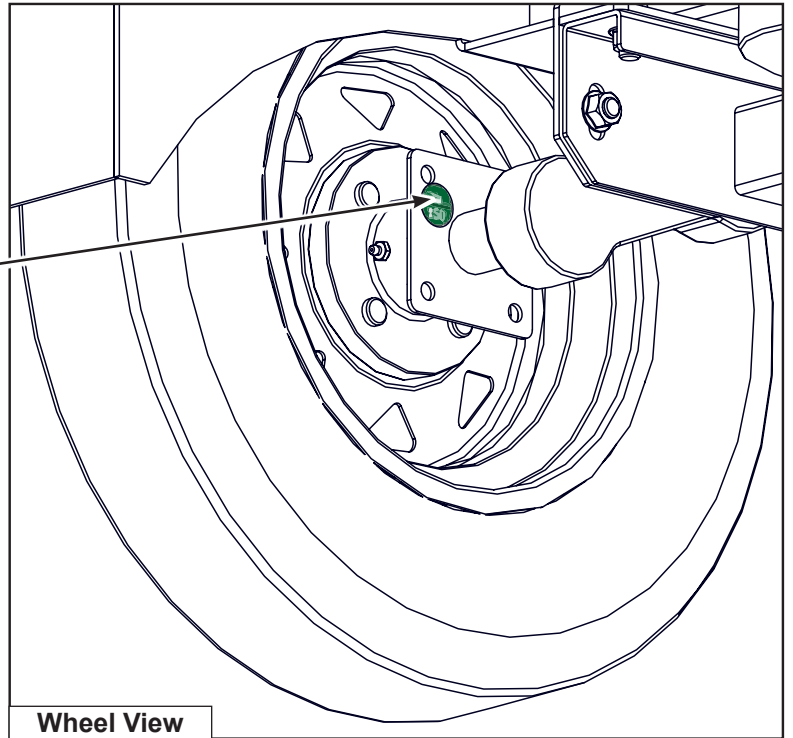

Z94426 x 2  
1 on each side

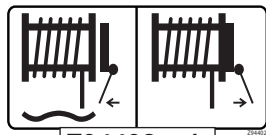

Z94402 x 1



Z94426 x 1

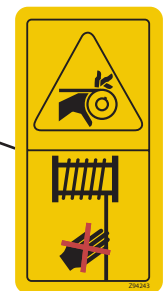
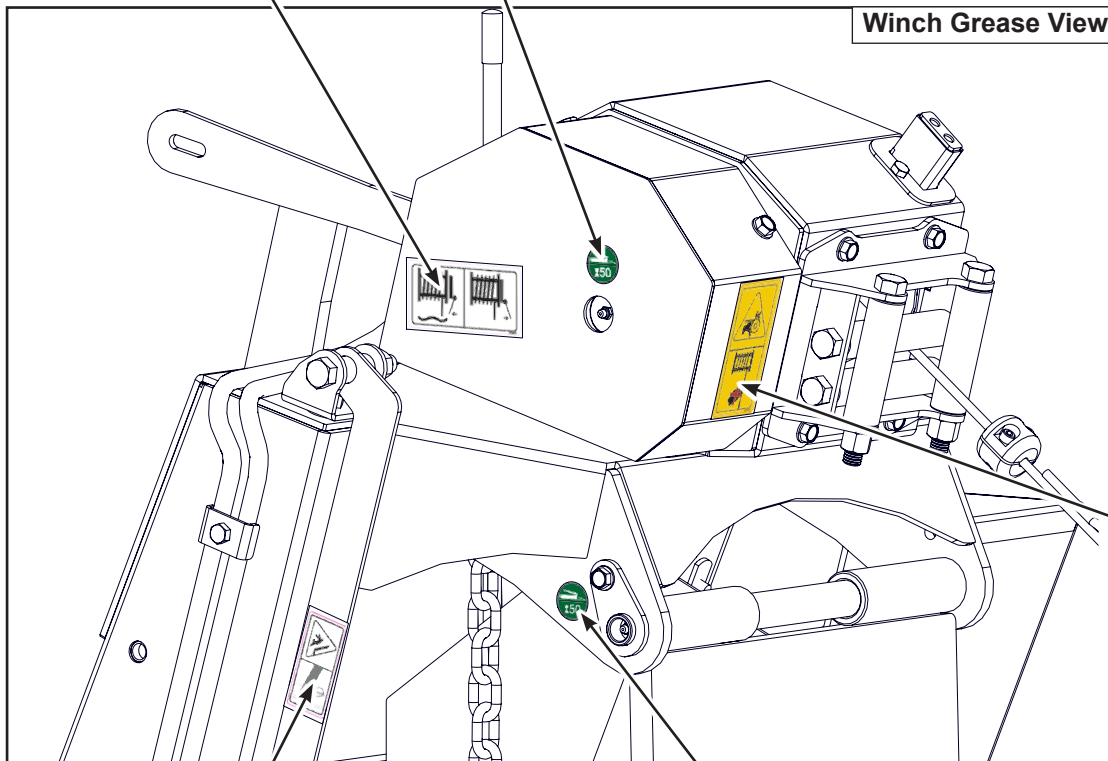

Z94243 x 1



Z94403 x 1



Z94426 x 2  
1 on each side



Control Panel Labels

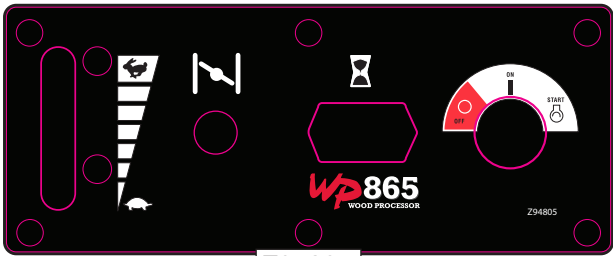

Z94805



Z94163

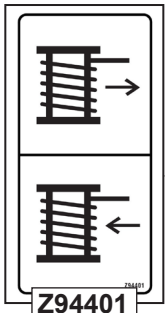

Z94401

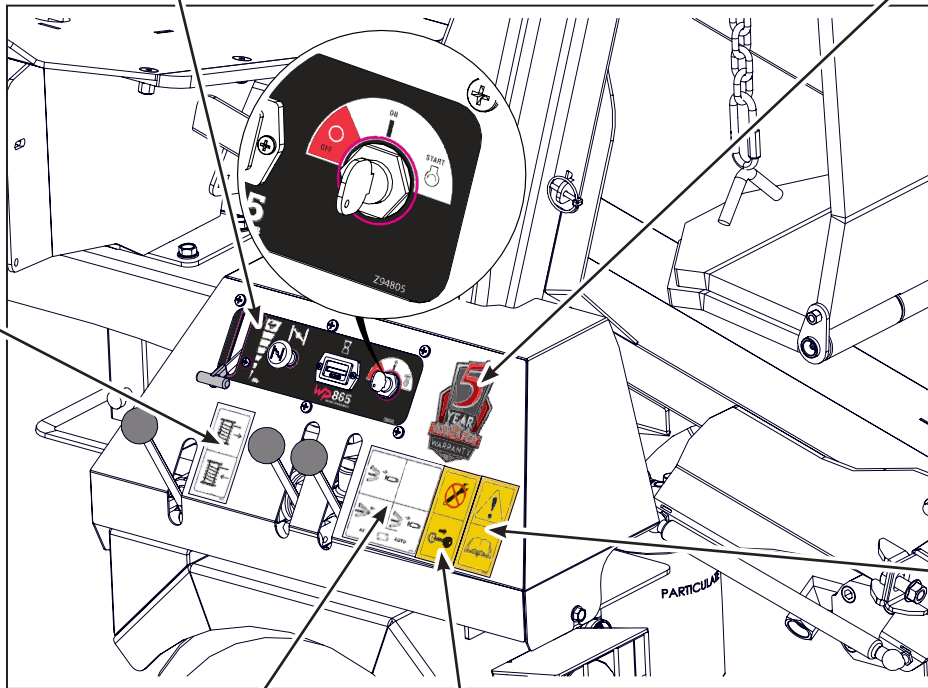

Z94119

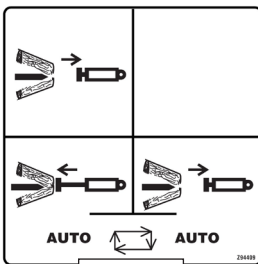

Z94409



Z94228



**Wiring Harnesses**

Part Number	Description	Qty
Z62124	Harness, WP800 Series Engine Control	1
Z62126	Harness, WP800 Series Lights	1

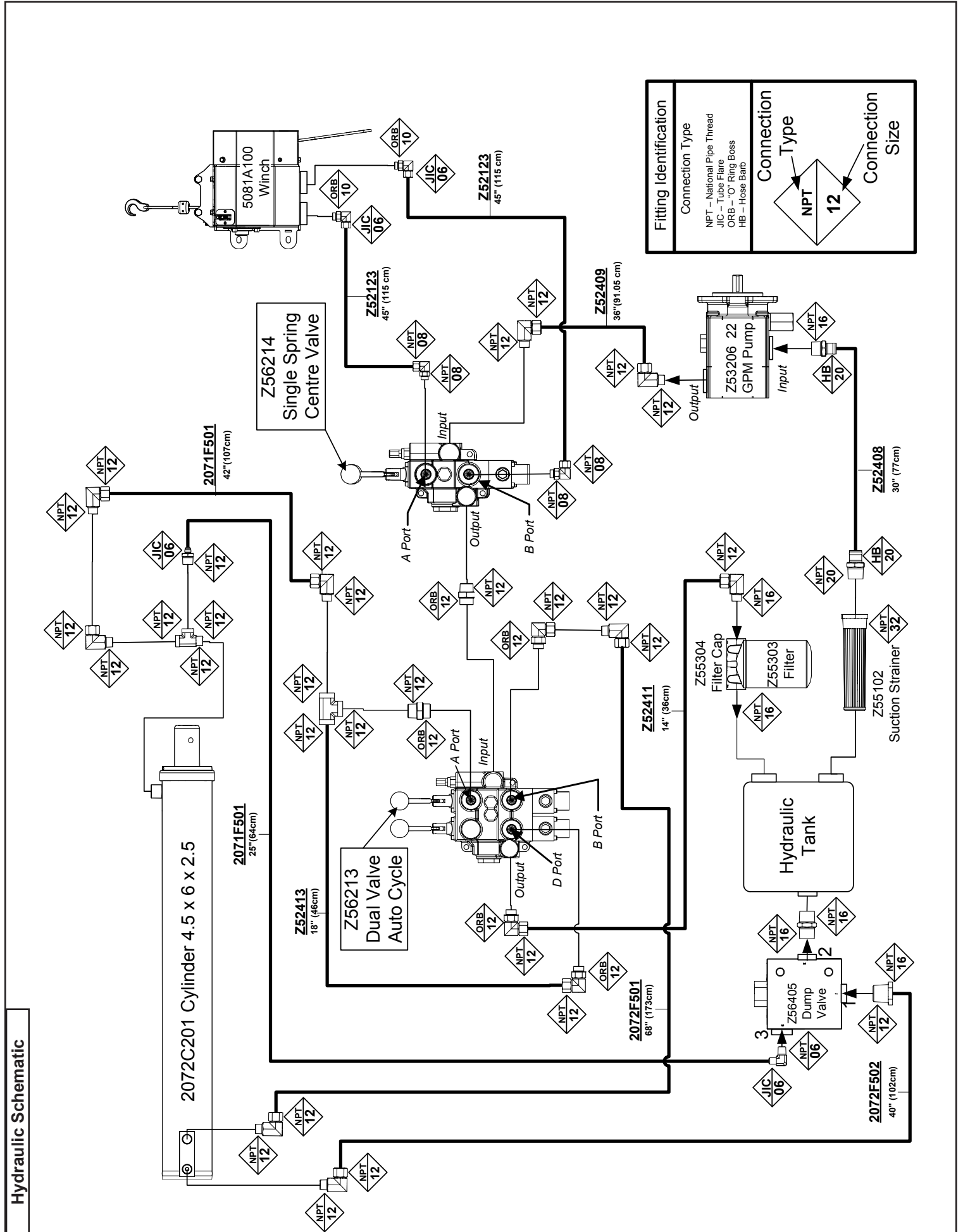

**Accessories**

Call your dealer for pricing and availability

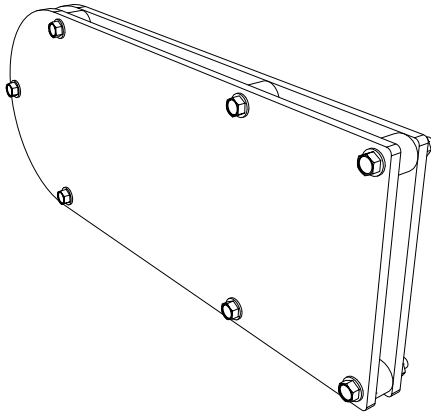

#P100 NYLON CHAINSAW HOLSTER

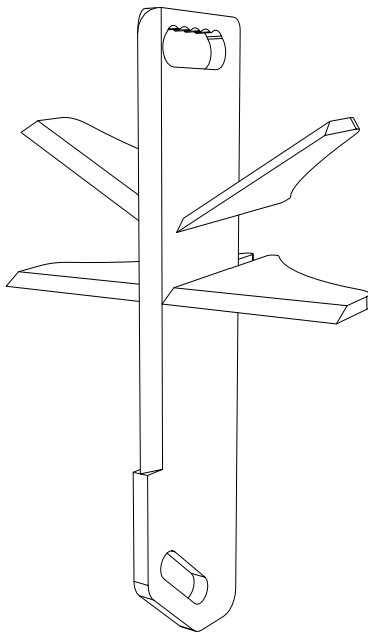

#P601 6-WAY WEDGE

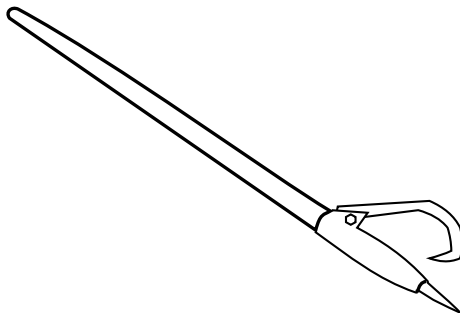

#299001 48" LOG PEAVEY

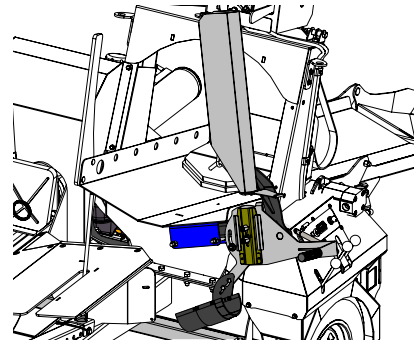

#P200

#P200 PIVOTING CHAINSAW HOLDER

For all WP Series  
Easy mounting to most chain saws, the pivoting chain saw holder securely holds your saw in place allowing for easier cutting and saving time handling your chainsaw.

Available:  
**P210 Spare Pivoting Chainsaw Adaptor**  
Save time switching out chainsaws with a spare adaptor for your second chainsaw!



EMB Manufacturing Inc.  
4144 Boomer Line - St. Clements, ON - N0B 2M0 - Canada  
Ph: (519) 699-9283 - Fax: (519) 699-4146  
www.embmfg.com

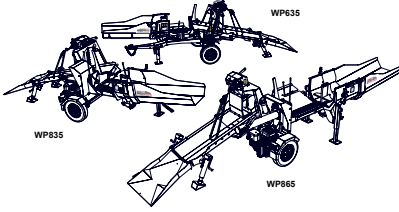

**Wood Processor  
MODEL WP635, WP835 & WP865  
OPERATOR'S MANUAL**

Before putting the Wood Processor into service:  
Do not attempt to start or operate the Wood Processor without receiving full safety training and instruction in its features, operation and maintenance. See page 4 for Pre-Delivery Procedure.

**Keep this manual with the  
Wood Processor at all times**

PRINTED IN CANADA  
Rev: 110215 PART NUMBER: Z97086

**#Z97086  
WOOD PROCESSOR  
OPERATOR'S MANUAL**

Available as a download at  
[www.embmfg.com](http://www.embmfg.com)