



**WX620 Trailer Log
Splitter Parts Manual**
Prior to S/N 26206



Foreword

EMB Mfg. has prepared this parts manual to assist customers in ordering quality OEM replacement parts.

Proper and regular service and replacing old, worn or broken parts with the correct Wallenstein parts are essential to prolonging the life of your Wallenstein product. Please refer to this manual before ordering any replacement parts.

All information contained in this parts manual is based on the latest product specification available at the time of printing this manual. If your product differs from the specifications contained within this manual contact EMB Mfg. for information.

EMB reserves the right to alter specifications on their products at any time.

Reproduction of this parts manual of any kind is prohibited without prior written permission from EMB Mfg.

Table of Contents

Cylinder	4
Valve & Fittings	4
Main Parts	5
Hub	6
Valve	7
Engine & Pump	8
Light Kit (Optional)	9
Decal Breakdown	10

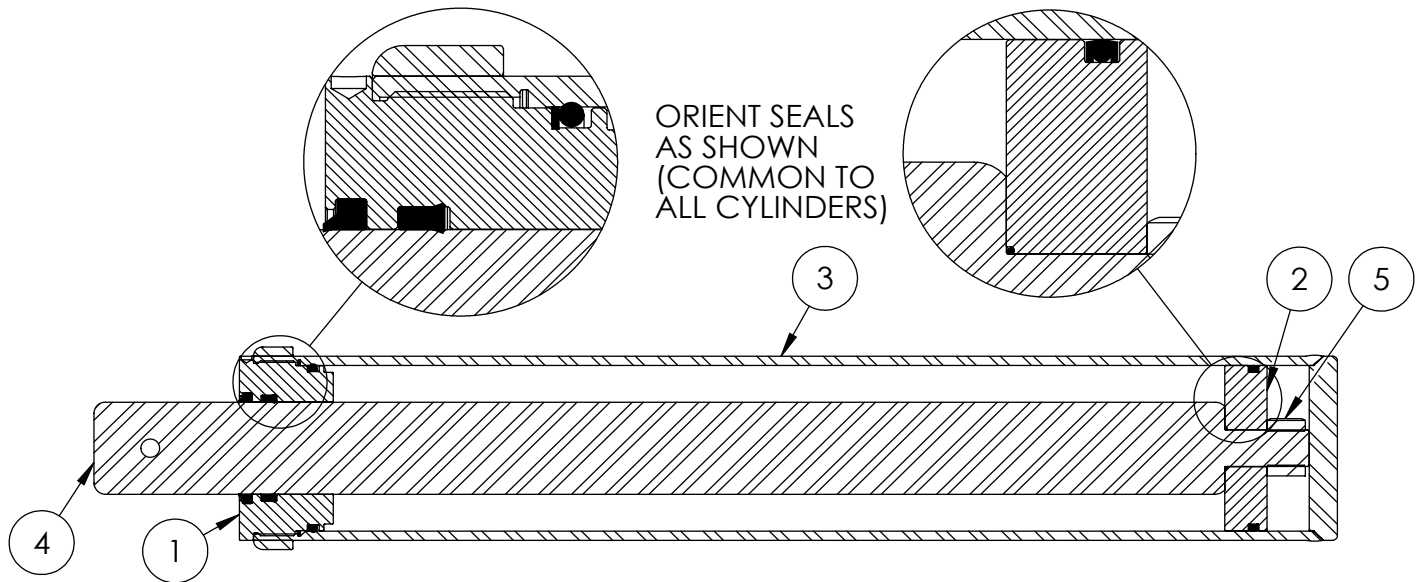

4-1/2" WOODSPLITTER CYLINDER PARTS BREAKDOWN

ITEM	PART NO.	DESCRIPTION	QTY
1	G450-250SA	4-1/2" Bore x 2-1/2" Rod Gland With Seals	1
2	P100-450SA	4-1/2" Bore Piston With Seals	1
3	2055C5014	Barrel, 4-1/2"	1
4	2055C5012	Rod, 2-1/2x 1	1
5	Z72292G8	Hex Lock Nut 1NF Grade 8	1
6	SLK-4525	Seal Kit, 4-1/2 x 2-1/2	1

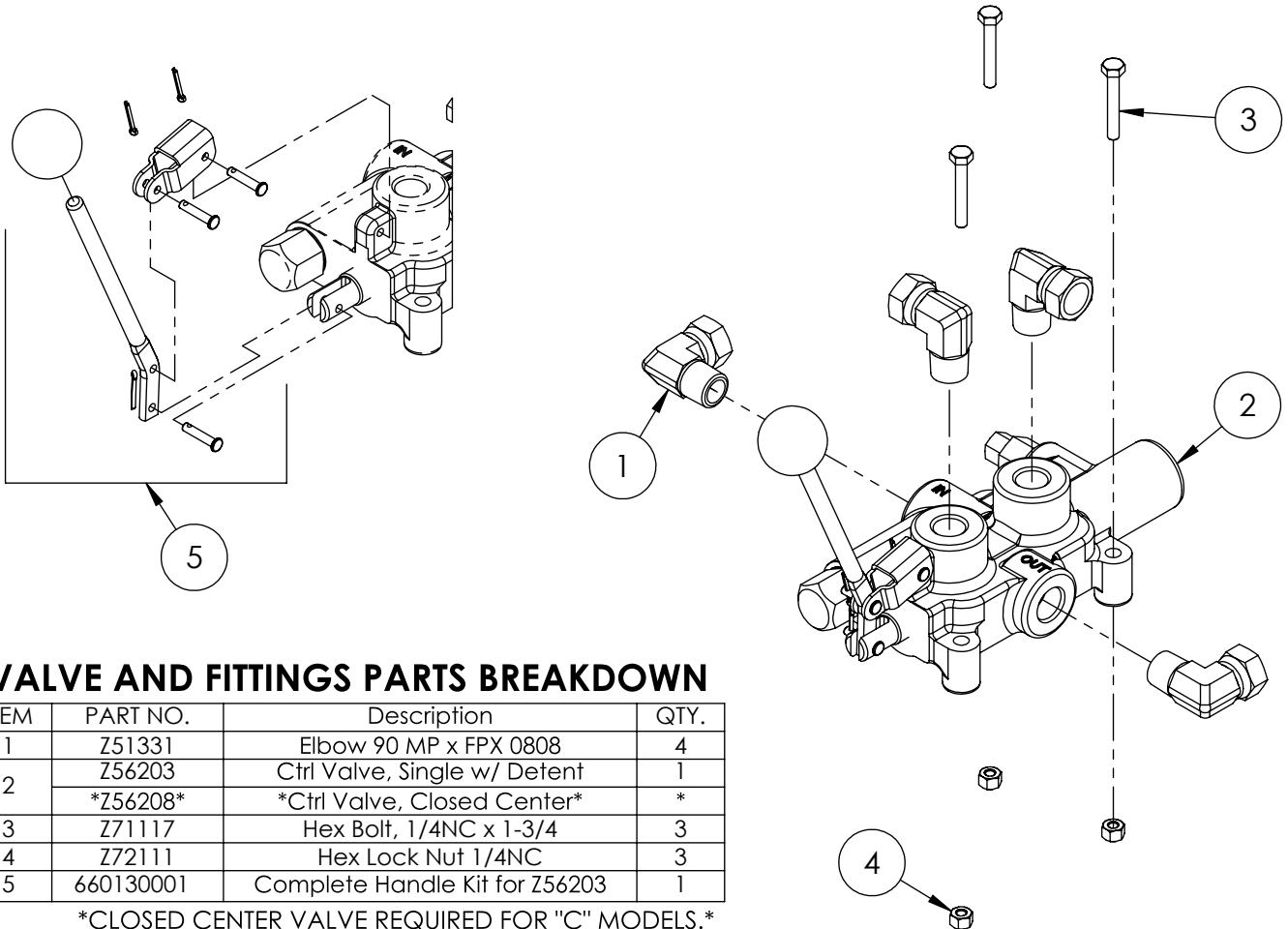

VALVE AND FITTINGS PARTS BREAKDOWN

ITEM	PART NO.	Description	QTY.
1	Z51331	Elbow 90 MP x FPX 0808	4
2	Z56203	Ctrl Valve, Single w/ Detent	1
	Z56208	*Ctrl Valve, Closed Center*	*
3	Z71117	Hex Bolt, 1/4NC x 1-3/4	3
4	Z72111	Hex Lock Nut 1/4NC	3
5	660130001	Complete Handle Kit for Z56203	1

CLOSED CENTER VALVE REQUIRED FOR "C" MODELS.

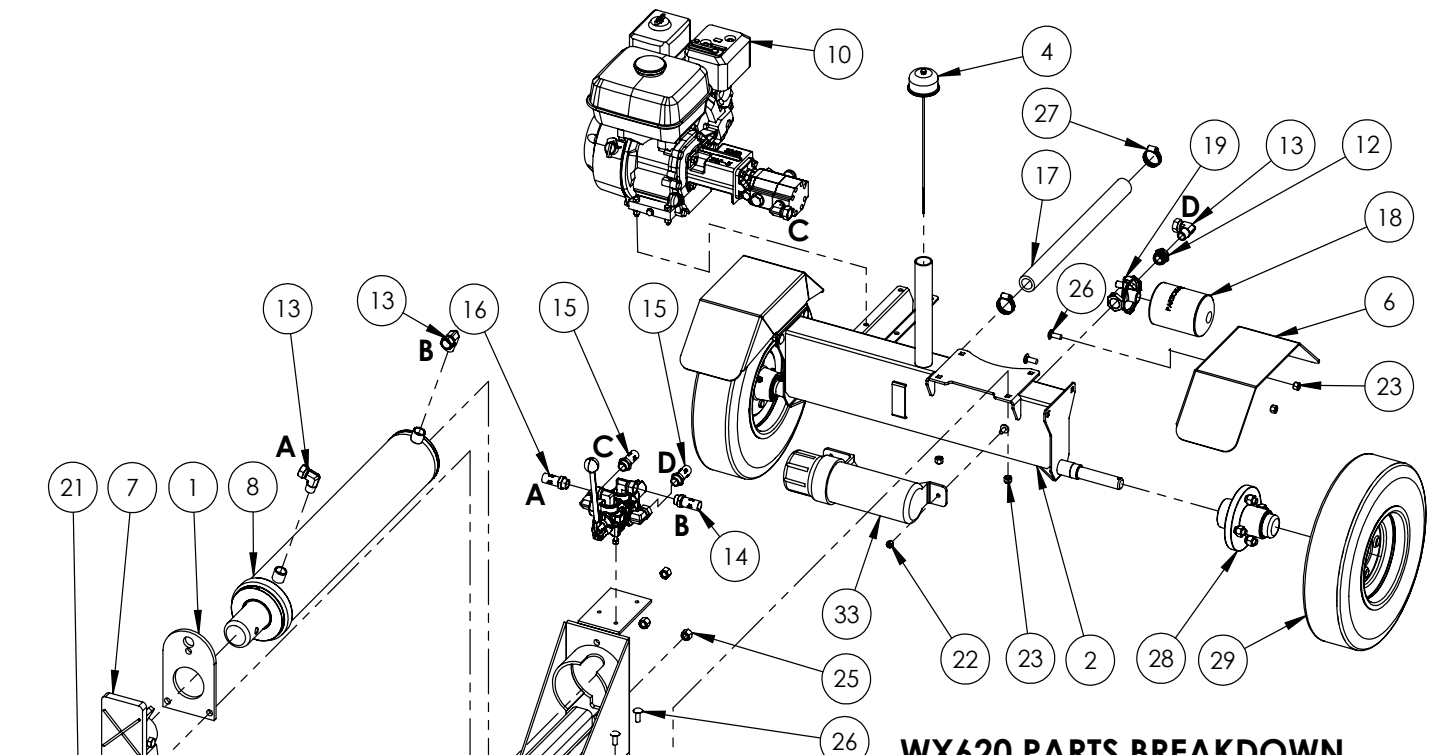

WX620 PARTS BREAKDOWN

ITEM	PART NO.	DESCRIPTION	QTY
1	2032S213	Plate, Cylinder Retaining	1
2	2052W701	Weldment, WX520 Main Base	1
3	2052W704	Weldment, Hitch Mount	1
4	2054A402	Breather cap dipstick	1
5	2054W406	Jack Stand, Front	1
6	2054W408	Weldment, Fender	2
7	2055A501	Ass'y, Sliding Hvy Pushblock	1
8	2055C501	Cylinder, 4-1/2 x 24 x 2-1/2	1
9	2055W501	Cylinder Weldment, WX910	1
10	2063A106	Assy, GX 6.5hp Engine to 11gpm Pump	1
11	Z12432	Snapper Pin 3/8 x 2-1/2	1
12	Z51221	Reducer FP x MP 1208	1
13	Z51331	Elbow 90 MP x FFX 0808	3
14	Z52301	1/2 Hose MP08 x MP08 x 16"	1
15	Z52303	1/2 Hose, 1/2MP x 1/2MP x 36"	2
16	Z52305	1/2 Hose, MP08 x MP08 x 24"	1
17	Z52404	Suction Hose, 1" x 18"	1
18	Z55301	Oil Filter - 3/4 - Particulate	1
19	Z55302	Filter Cap, 3/4 x 3/4	1
20	Z71530	Hex Bolt 1/2NC x 3	2
21	Z71560	Hex Bolt 1/2NC x 6	3
22	Z72221	Hex Lock Nut 5/16NC	1
23	Z72231	Hex Lock Nut 3/8NC	8
24	Z72251	Hex Lock Nut 1/2NC	4
25	Z72251	Hex Lock Nut 1/2NC	5
26	Z76231	Carriage Bolt 3/8NC x 1	8
27	Z79401	Hose Clamp, #16	2
28	Z91202	Assembly, 1000# 4-Bolt Hub	2
29	Z91301	4.80-8 LRB SportTrail	2
30	Z91614	2" Hitch Coupler	1
31	Z92303	Safety Chain 1/4 x 2'	2
32	Z92303-2	Safety Snap	2
33	Z96503	Manual Tube 3-1/2 Short	1

ITEM	PART NO.	DESCRIPTION	QTY
40	2055S517	Cap, Push Block	1
41	2055W509	Weldment, Hvy Push Block	1
42	Z71537	Hex Head Bolt, 1/2NC x 3-3/4	1
43	Z71576	Hex Bolt 1/2NF x 1-1/2	3
44	Z72251	Hex Lock Nut 1/2NC	1

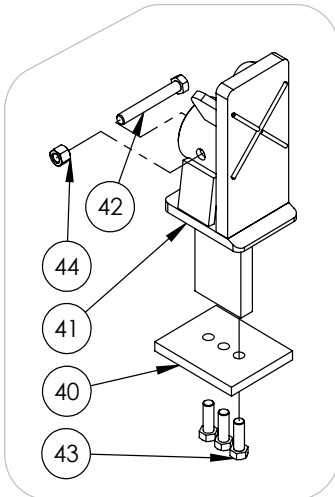

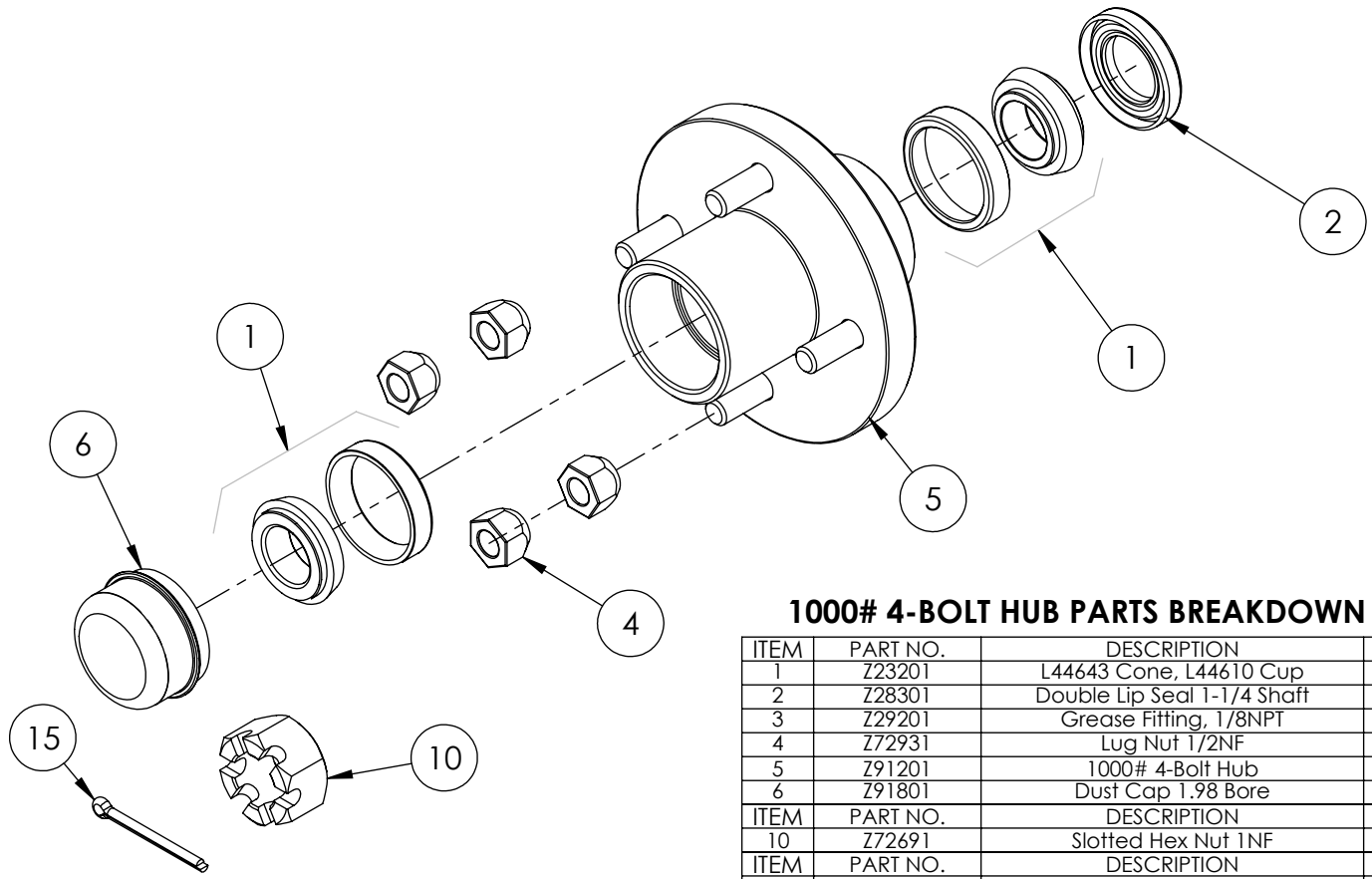

1000# 4-BOLT HUB PARTS BREAKDOWN

ITEM	PART NO.	DESCRIPTION	QTY
1	Z23201	L44643 Cone, L44610 Cup	2
2	Z28301	Double Lip Seal 1-1/4 Shaft	1
3	Z29201	Grease Fitting, 1/8NPT	1
4	Z72931	Lug Nut 1/2NF	4
5	Z91201	1000# 4-Bolt Hub	1
6	Z91801	Dust Cap 1.98 Bore	1
ITEM	PART NO.	DESCRIPTION	QTY
10	Z72691	Slotted Hex Nut 1NF	1
ITEM	PART NO.	DESCRIPTION	QTY
15	Z12322	Cotter Pin 3/16 X 2	1

Z56203 Valve Breakdown

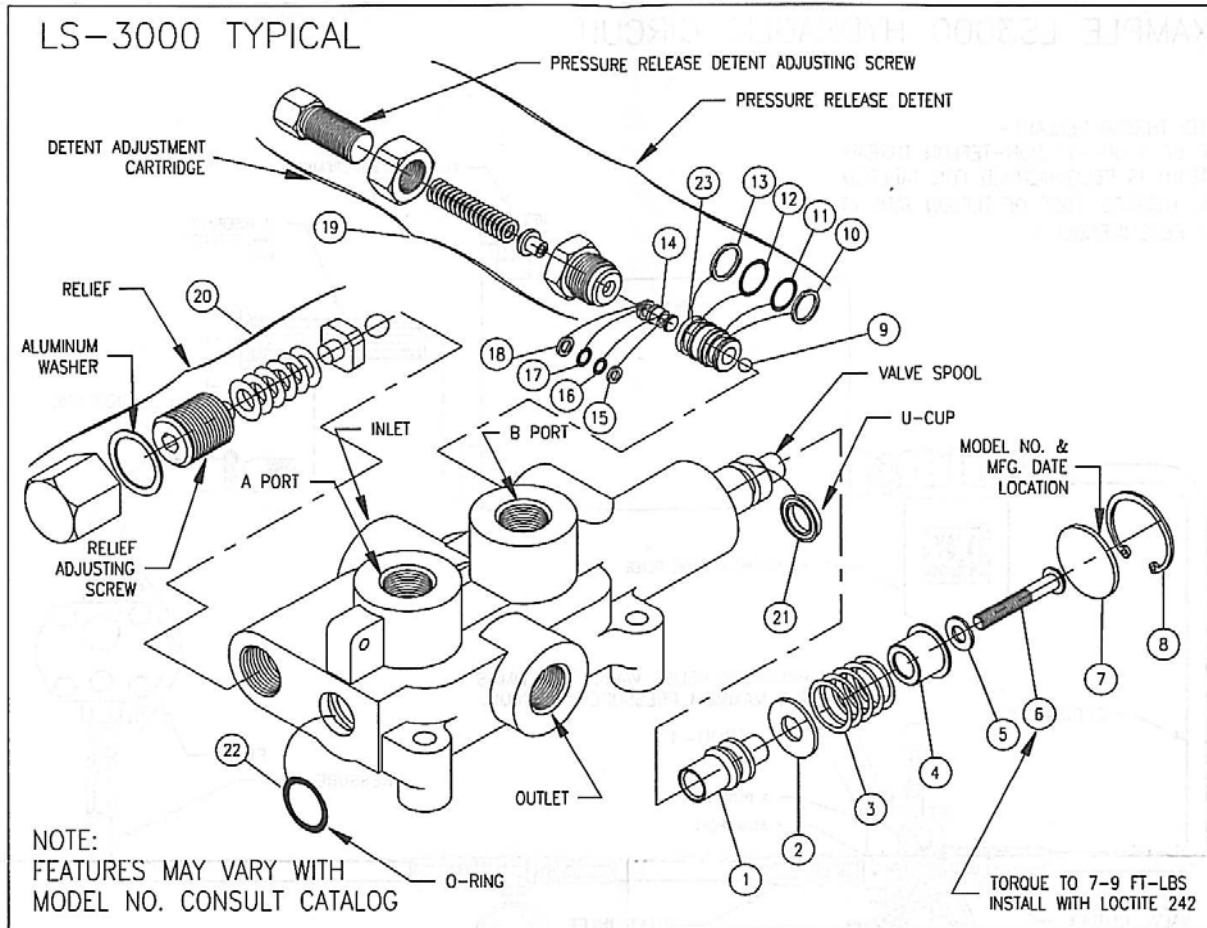

PLEASE NOTE:
BEFORE REMOVING VALVE SPOOL OR SPOOL SLEEVE REMOVE DETENT ADJUSTING CART., DETENT PISTON AND STEEL BALL. INSTALL SPOOL AND SPOOL SLEEVE BEFORE REINSTALLING STEEL BALL.

LS-3000 KITS AND CARTRIDGES

PRESSURE RELEASE DETENT
This feature provides a pressure release detent for the spool 'out' (handle in) position. When the spool is manually placed in the 'detent' position oil is directed to the 'B' work port (the port away from the handle). When the pressure in the 'B' port reaches a preset level the detent will release and the spool will center. The factory setting is 1400 psi. The detent release pressure is adjustable by loosening the jam nut and turning the adjusting screw. Turning the adjusting screw clockwise will increase the detent release pressure and counterclockwise will decrease the detent release pressure. NOTE: if the detent release pressure is set too high the spool will not center, if the pressure is too low the detent will not hold. If cap screw item 6 becomes loose detent will not function properly.

RELIEF VALVE
An adjustable ball spring relief valve is standard on all LS-3000 valves. The standard factory setting is 2250 psi @ 3 gpm and 120°F. Other settings can be specified. The relief pressure is adjusted by removing acorn nut, and turning the adjusting screw. Turning the adjusting screw clockwise will increase the pressure and counterclockwise will decrease the pressure (a pressure gauge must be installed in the inlet line whenever the relief pressure is adjusted). Do not backout adjusting screw to the point it falls out.

⚠ WARNING: OVERPRESSURE MAY CAUSE SUDDEN AND UNEXPECTED FAILURE OF A COMPONENT IN THE HYDRAULIC SYSTEM RESULTING IN SERIOUS PERSONAL INJURY. ALWAYS USE A GAUGE WHEN ADJUSTING A RELIEF VALVE.

ITEM	QTY	PART NO.	DESCRIPTION
1	1		DETENT SLEEVE
2	1		WASHER
3	1		SPRING
4	1		STOP CUP
5	1		WASHER
6	1		CAP SCREW
7	1		SPACER
8	1		SNAP RING
9	1		STEEL BALL
10	1		BACK-UP WASHER
11	1		O-RING
12	1		O-RING
13	1		BACK-UP WASHER
14	1		PISTON
15	1		BACK-UP WASHER
16	1		O-RING
17	1		O-RING
18	1		BACK-UP WASHER
19	1		DETENT ADJUSTING CART.
20	1		RELIEF KIT
21	1		U-CUP
22	1		O-RING
23	1		PISTON SLEEVE
		660530001	LS-3000 SEAL KIT
		660125004	RELIEF KIT
		660330002	DETENT ADJUSTING CART.
		660130007	PRESSURE RELEASE DETENT KIT
		660130001	COMPLETE HANDLE KIT

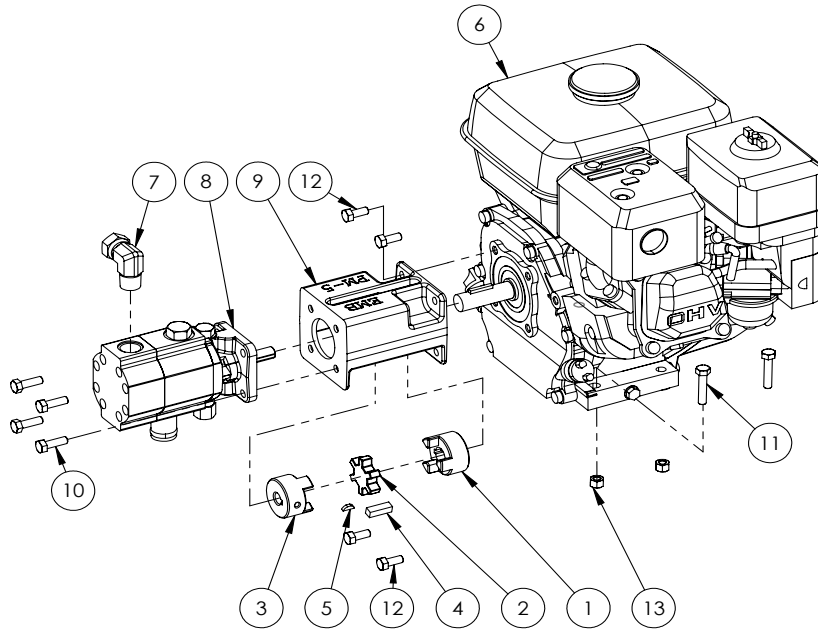

2063A105 PARTS BREAKDOWN

ITEM	PART NO.	DESCRIPTION	QTY
1	Z46406	Shaft Coupler L075 x 3/4	1
2	Z46408	Coupler Spider L075	1
3	Z46407	Shaft Coupler L075 x 7/16	1
4	Z46542	Key 5/16 x 5/16 x 1	1
5	Z46592	Woodruff Key, 1/8 x 1/2	1
6	Z47131	Honda GX200 Engine	1
7	Z51383	Elbow 90 MP x FPX 0808	1
8	Z53201	Pump, 11gpm Two-Stage	1
9	Z53801	Pump Mounting, PM-5	1
10	Z71210	Hex Bolt, 5/16NC x 1	4
11	Z71215	Hex Bolt, 5/16NC x 1-1/2	4
12	Z71273	Hex Bolt, 5/16NF x 3/4	4
13	Z72221	Hex Lock Nut 5/16NC	4

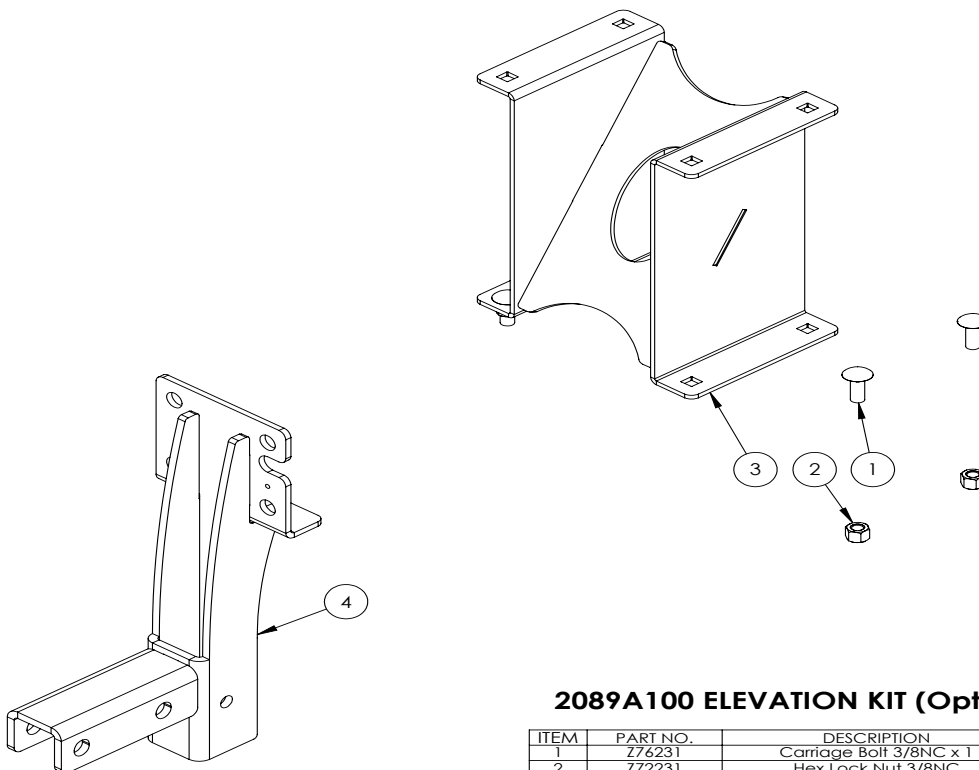

2089A100 ELEVATION KIT (Optional)

ITEM	PART NO.	DESCRIPTION	QTY
1	Z76231	Carriage Bolt 3/8NC x 1	4
2	Z72231	Hex Lock Nut 3/8NC	4
3	2089W101	Weldment, Tank Spacer	1
4	2089W104	Weldment, Hitch Mount	1

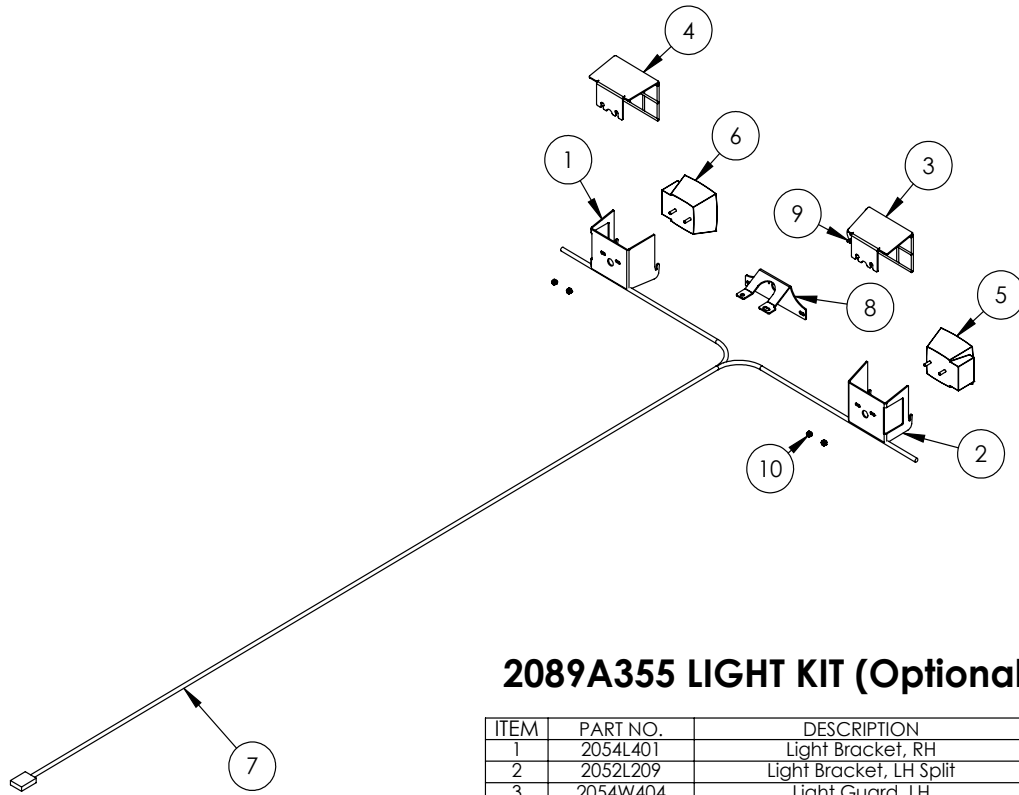

2089A355 LIGHT KIT (Optional)

ITEM	PART NO.	DESCRIPTION	QTY
1	2054L401	Light Bracket, RH	1
2	2052L209	Light Bracket, LH Split	1
3	2054W404	Light Guard, LH	1
4	2054W403	Light Guard, RH	1
5	Z61106	Stop, Turn, Tail Light LH	1
6	Z61107	Stop, Turn, Tail Light RH	1
7	Z62102	10' Wishbone Trailer Harness	1
8	2052L210	License Bracket	1
9	Z61301	License Lamp	1
10	Z72941	Serrated Washer Nut 1/4NC	4

WX TRAILER SPLITTER WIRING

RIGHT SIDE

KEY

- Bl - BLUE
- Br - BROWN
- Gr - GREEN
- Rd - RED
- Yl - YELLOW
- Bk - BLACK
- Wh - WHITE

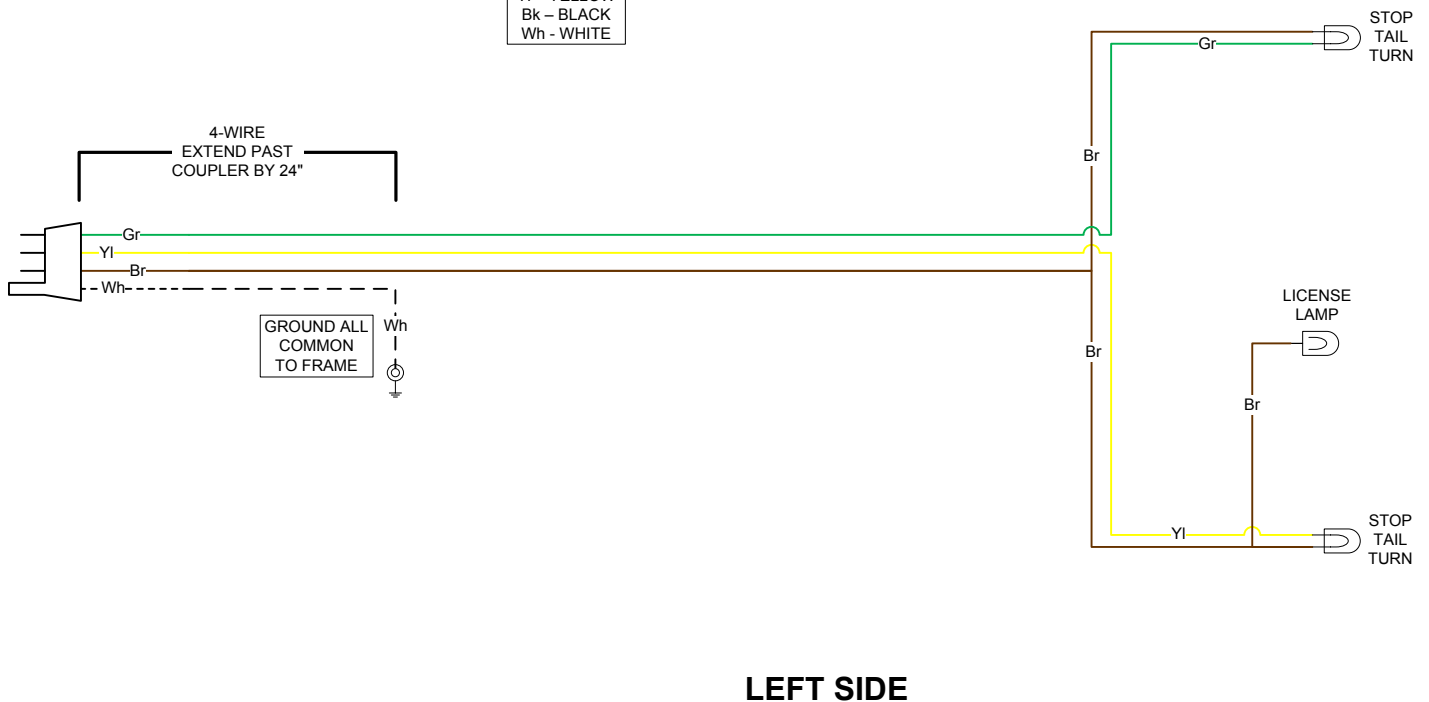

HORIZONTAL LOG SPLITTER DECAL BREAKDOWN

ITEM	PART NO.	DESCRIPTION	QTY
1	Z94039	CAUTION - Read Manual	1
2	Z94040	WARNING - Moving Wedge	2
3	Z94067	Clear Guide	2
4	Z94056	Wallenstein	2
5	Z94019	Made in Canada	3
6	Z94066	Apply Oil or Grease	1

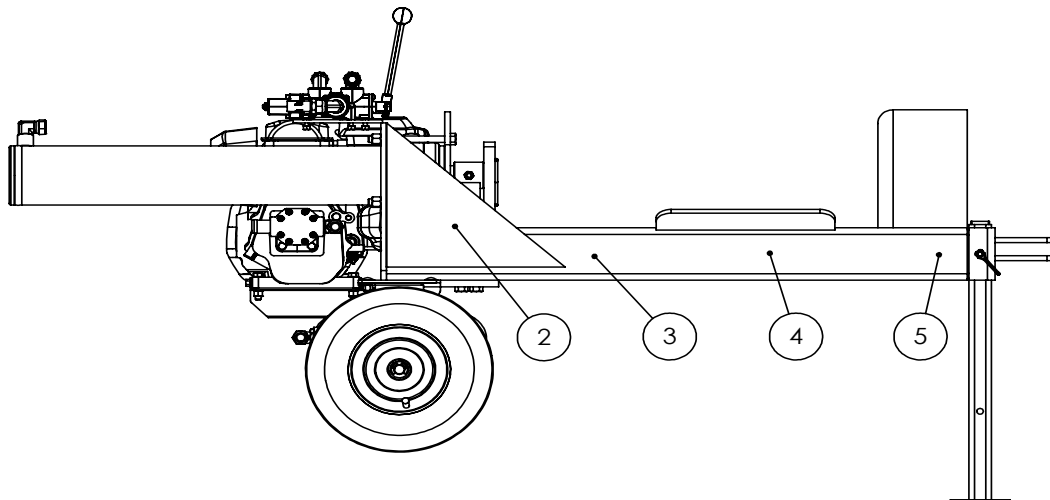
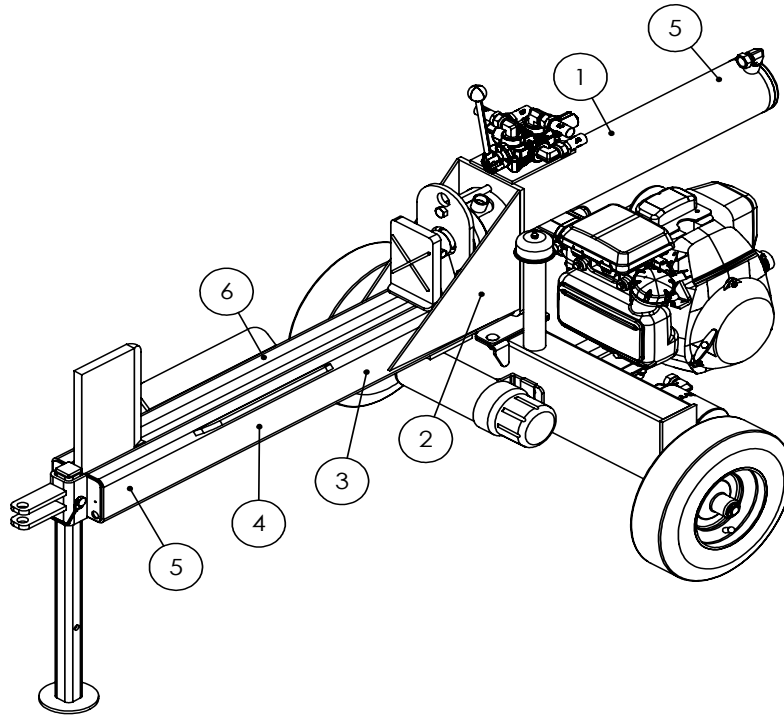

Trailer Splitter Decals

Z94056



Z94067



Z94019



Z94066



Z94039



Z94040





WALLENSTEIN Products Manufactured by:

EMB MFG Inc.

4144 Boomer Line
St. Clements, Ontario
Canada N0B 2M0
Phone: 1-877-695-9283
Fax: 519-699-4146
www.embmfg.com